

KR-28

WHIRLPOOL GAS RANGE DIRECT SPARK IGNITION SYSTEM



**JOB AID
Part No. 8177893**

FORWARD

This Job Aid, "Whirlpool Gas Range Direct Spark Ignition System," (Part No. 8177893), provides the technician with information on the operation and service of the Direct Spark Ignition System. It is to be used as a training Job Aid and Service Manual.

The Wiring Diagrams used in this Job Aid are typical and should be used for training purposes only. Always use the Wiring Diagrams supplied with the product when servicing the unit.

GOALS AND OBJECTIVES

The goal of this Job Aid is to provide detailed information that will enable the service technician to properly diagnose malfunctions and repair the Direct Spark Ignition System.

The objectives of this Job Aid are to:

- Understand and follow proper safety precautions.
- Successfully troubleshoot and diagnose malfunctions.
- Successfully perform necessary repairs.
- Successfully return the Direct Spark Ignition System to the proper operational status.

WHIRLPOOL CORPORATION assumes no responsibility for any repair made on our products by anyone other than Authorized Factory Service Technicians.

Copyright 2000, Whirlpool Corporation, Benton Harbor, MI 49022

Table of Contents

PAGE

SECTION 1	1
THEORY OF OPERATION	1
Introduction	1
Gas Distribution Valve	2
Manual Oven Shutoff Valve	3
Bake & Broil Solenoid-Activated Ports	4
L.P. Gas Conversion	5
Direct Spark Ignition Control	7
Electronic Spark Ignition	8
Cooktop Burner Operation	8
Oven Burner Operation	9
SECTION 2	11
COMPONENT ACCESS	11
Removing The Direct Spark Ignition Control	11
Removing The Gas Distribution Valve	12
SECTION 3	13
COMPONENT TESTING	13
Direct Spark Ignition Control	13
Gas Distribution Valve	17
SECTION 4	19
WIRING DIAGRAM & STRIP CIRCUITS	19
Wiring Diagram	19
Strip Circuits	20
SECTION 5	23
TECH TIPS	23
Diagnostic Flow Charts	23

IMPORTANT SAFETY INFORMATION

Your safety and the safety of others is very important.

Important safety messages have been provided in this Job Aid. Always read and obey all safety messages.



This is the safety alert symbol.

This symbol alerts you to hazards that can kill or hurt you and others.

All safety messages will be preceded by the safety alert symbol and the word **“WARNING.”**

All safety messages will identify the hazard, tell you how to reduce the chance of injury, and tell you what can happen if the instructions are not followed.

GENERAL INFORMATION

IMPORTANT MODEL & SERIAL NUMBER INFORMATION

The Direct Spark Ignition System is used on Whirlpool gas ranges produced, beginning January 3, 2000, Serial Code RK02. The Model number of these units will be a “-5” version of the current G-line gas range.

Example: **SF365PEGQ5**

This Direct Spark Ignition System will only be available on self-cleaning gas ranges.

ELECTRICAL REQUIREMENTS

The supply voltage is critical for proper operation of the Direct Spark Ignition (DSI) System. The requirements are 102 to 132 VAC with the proper polarity and ground. If the electrical supply is less than 102 VAC, sparking will not be reliable. If the system is over 132 VAC, permanent damage to the DSI can occur.

Proper polarity must also be supplied. If the supply polarity is reversed, the DSI control will not be able to detect the presence of a flame. Reverse polarity will not affect the cooktop operation, but the Bake and Broil burners will fail to remain lit.

A proper ground is also required. The DSI control generates a significant amount of electrical noise. This noise is minimized by clamping the noise to ground. If a proper ground is not connected, the ERC may periodically display “PF,” which means that a reset has occurred in the ERC.

GAS REQUIREMENTS

Gas supply pressure should be a minimum of 7” water column pressure for natural gas, and 11” water column pressure for L.P. gas. However, the gas distribution valve should maintain 4” water column pressure for natural gas, and 10” water column pressure for L.P. gas.

NOTE TO TECHNICIAN: Improper polarity will cause the direct spark ignition system to malfunction. Always check for proper polarity at the wall outlet before replacing parts.

SECTION 1

THEORY OF OPERATION

INTRODUCTION

The Direct Spark Ignition System contains a Gas Distribution Valve and a Direct Spark Ignition (DSI) Control that interfaces with the Electronic Oven Control, and spark electrodes. This provides the direct spark ignition and gas distribution for Whirlpool self-cleaning gas free-standing ranges.

A proper ground and the correct polarity is necessary for the DSI control to sense the pres-

ence of a flame. If the polarity is reversed, or in some cases if there is a poor ground, the control will appear to operate normally. However, after an oven burner ignites, the spark will continue to occur at the burner, and the valve will then shut off after 4 seconds. This is because the DSI control does not recognize the presence of a flame when one is present (see "Monitoring System," on page 9).

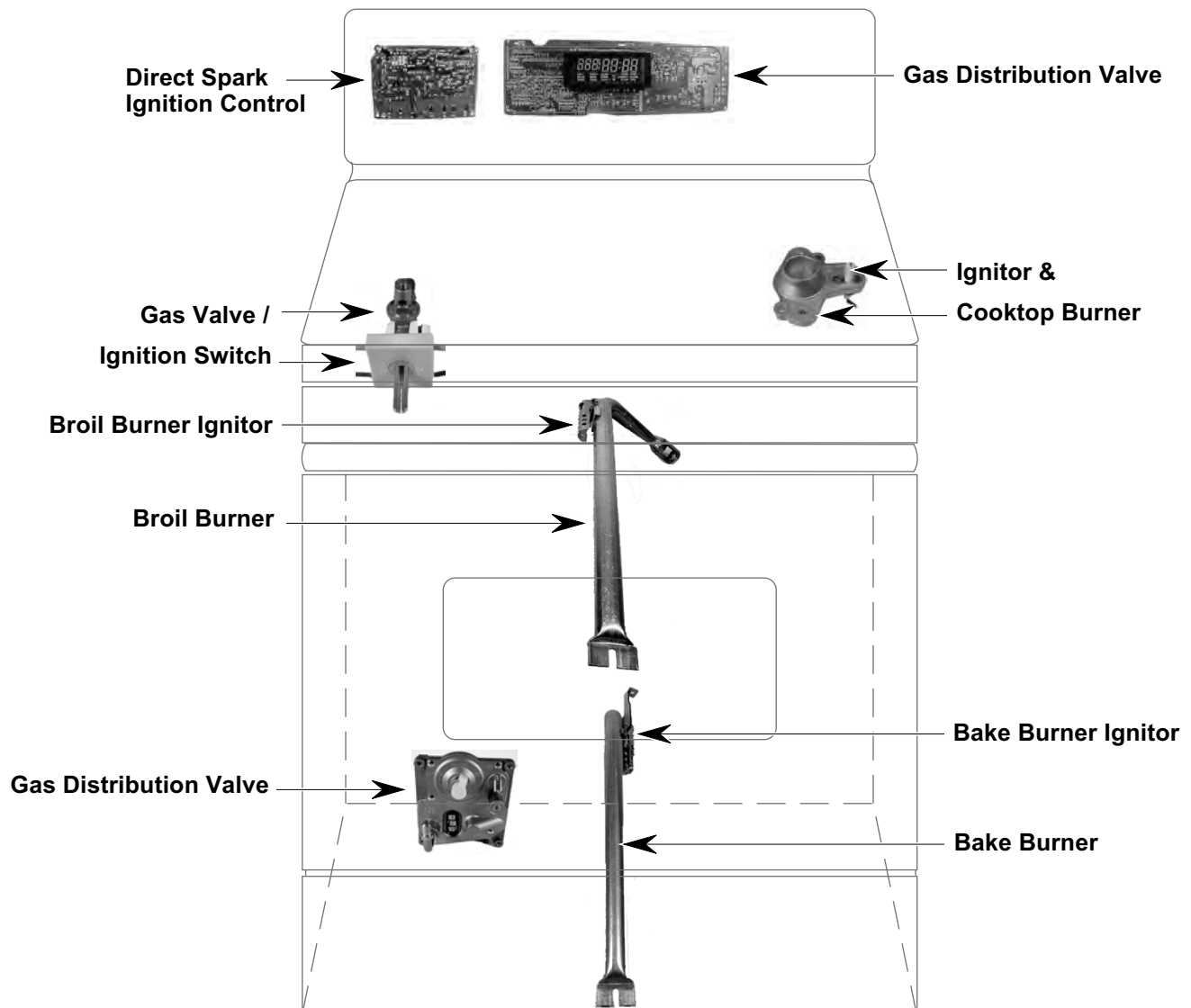

GAS DISTRIBUTION VALVE

The gas distribution valve can be converted to L.P. gas, when necessary. It regulates the distribution of gas to the cooktop and both oven burners. The gas distribution valve is non-serviceable.

The gas distribution valve is made up of the following features:

- Natural & L.P. gas regulator
- Manual oven shutoff valve
- Bake & broil solenoids
- Pressure tap - To measure gas outlet pressure

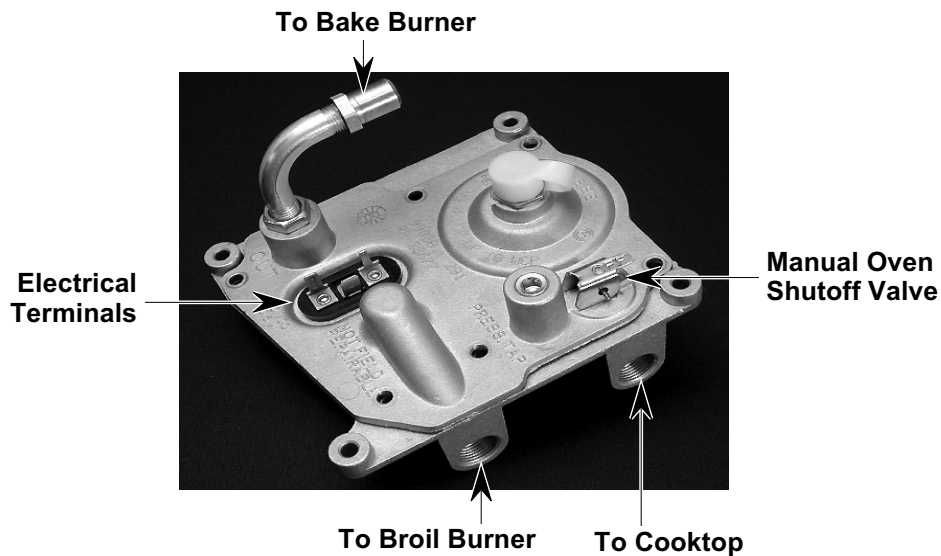
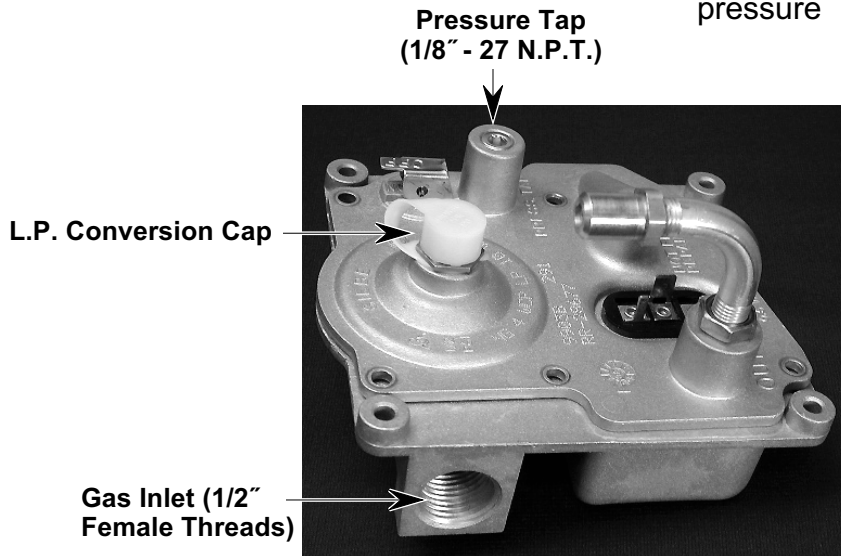

Gas Distribution Valve

MANUAL OVEN SHUTOFF VALVE

A manual oven shutoff valve is available on the gas distribution valve to shut off the gas to the oven burners. This valve will not affect the operation of the cooktop burners. When the lever is down, the gas to the oven burners is turned off.

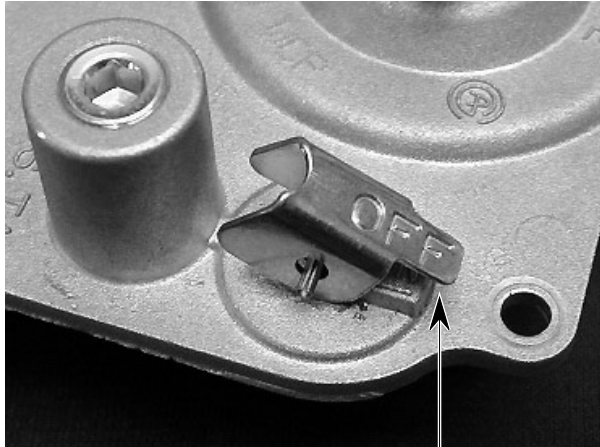

Manual Valve Lever
Down (Gas Off)

When the lever is raised, the gas to the oven burners is turned on.

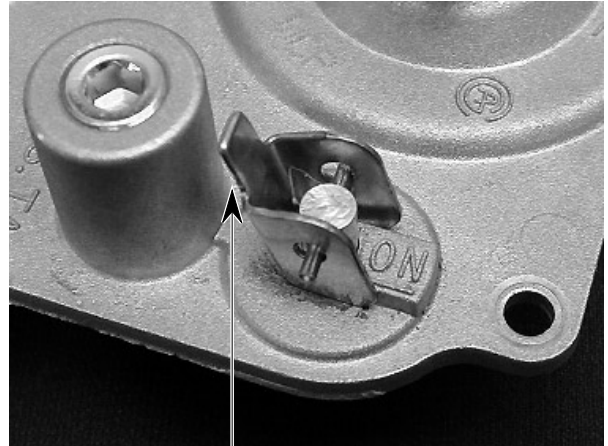

Manual Valve Lever
Raised (Gas On)

BAKE & BROIL SOLENOID-ACTIVATED PORTS

The bake and broil gas supply ports are opened and closed by electrically-operated solenoids. When voltage is received from the spark ignition control for the bake or broil function, (8-18 VDC), the solenoid for that function is activated, and the valve opens to allow gas

flow to the burner. The electrical connections at the valve consist of three terminals, each one sized differently to prevent incorrect wiring (see below).

The solenoids require special voltage/current (8 - 18 VDC) from the direct spark ignition control to operate properly. **IMPORTANT: Do not attempt to operate the solenoids with any other voltage supply.**

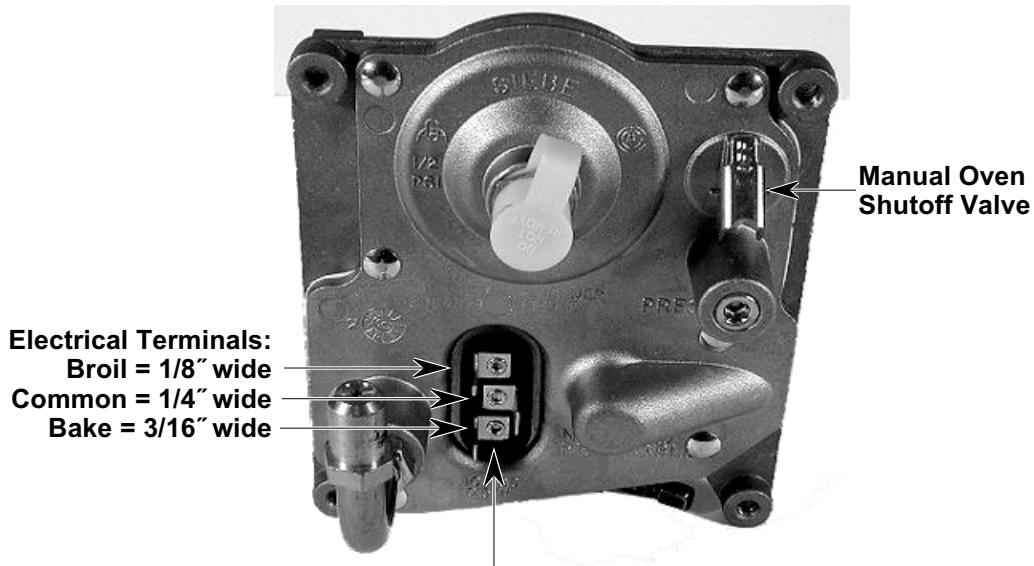

216 Ω Resistance Across Each Solenoid Terminal
8 to 18 VDC

NOTE: Always check both solenoids. If either solenoid is defective, neither one will operate.

L.P. GAS CONVERSION

The range is manufactured to use natural gas. To convert the range to use L.P. gas, the following steps are performed:

1. Turn off the gas and electrical supplies to the range.
2. Remove the storage drawer from the range.
3. Locate the gas distribution valve at the rear of the range. To convert the gas distribution valve:

a) Unscrew the conversion cap from the gas distribution valve. Note the difference between the L.P. and natural gas ends of the cap.

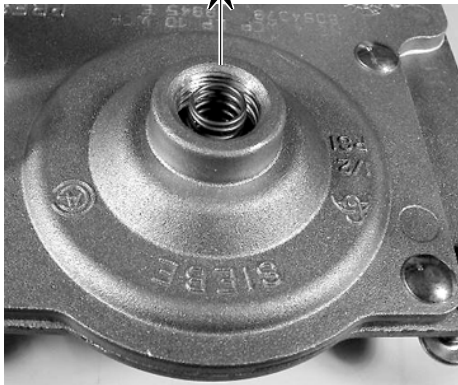
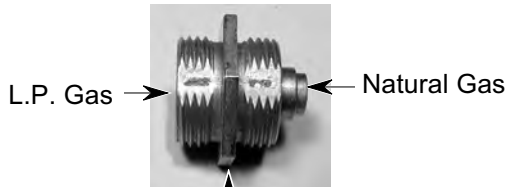

b) Install the conversion cap on the gas distribution valve with the L.P. side facing up (you will see L.P. stamped inside the cap, as shown).

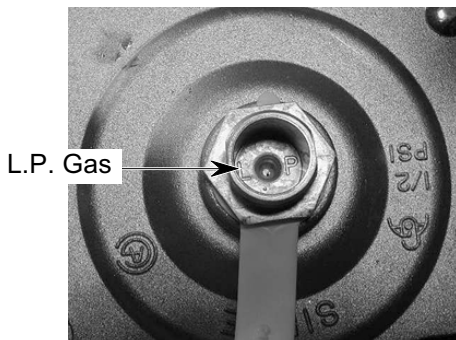

4. To convert the bake burner:
 - a) Open the oven door and remove the oven racks.
 - b) Use a 1/2" open-end wrench and turn the orifice hood down snug onto the pin (approximately 2-1/2 turns). **DO NOT OVERTIGHTEN THE ORIFICE.** The burner flame cannot be properly adjusted if this conversion is not made.

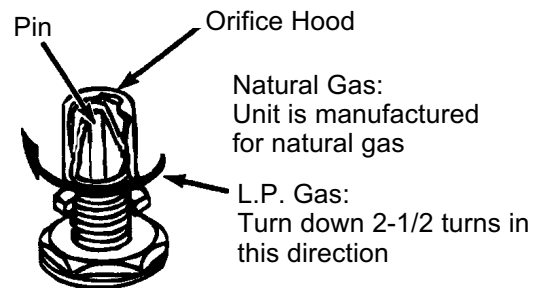

5. To convert the cooktop burners:

NOTE: The L.P. orifices for the cooktop burners are supplied in the literature pack inside the oven.



a) Use an 8 mm socket and carefully remove the orifice spud from each of the four burners.

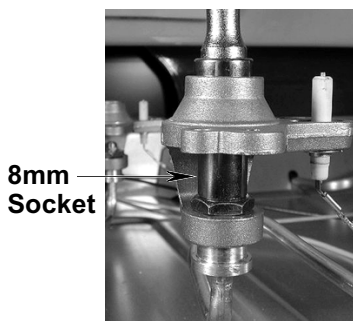

b) Install the four L.P. gas orifices in the burners.

6. To convert the broil burner:

a) Open the oven door and remove the oven racks.

b) Use a 1/2" open-end wrench and turn the orifice hood down snug onto the pin (approximately 2-1/2 turns). DO NOT OVERTIGHTEN THE ORIFICE. The burner flame cannot be properly adjusted if this conversion is not made.

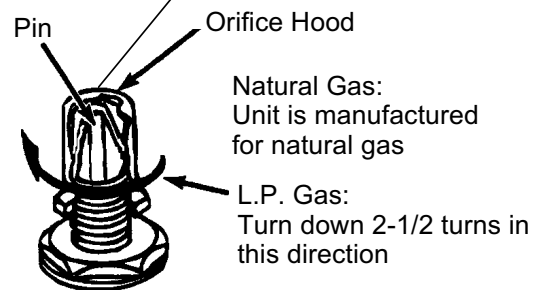
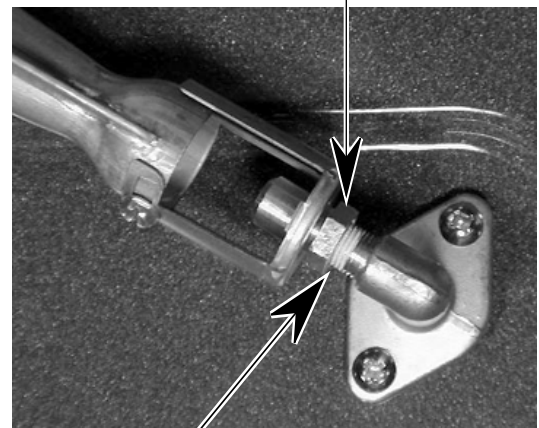
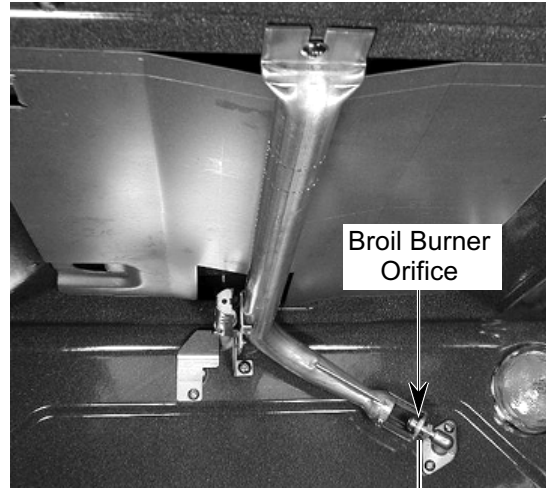

7. Reinstall the storage drawer and oven racks.

DIRECT SPARK IGNITION CONTROL

The Direct Spark Ignition (DSI) Control interfaces with the Electronic Oven Control for the Bake, Broil, and Self-Clean functions. The DSI also interfaces with the four cooktop burner ignition switches, to provide ignition for the cooktop.

The DSI control uses a self-diagnostic test to verify that the oven ignition system is working properly. It will also continually monitor the flame presence within the oven. The DSI control operates on 102 to 132 VAC. All input and output testing is performed at the J1 connector (see below).

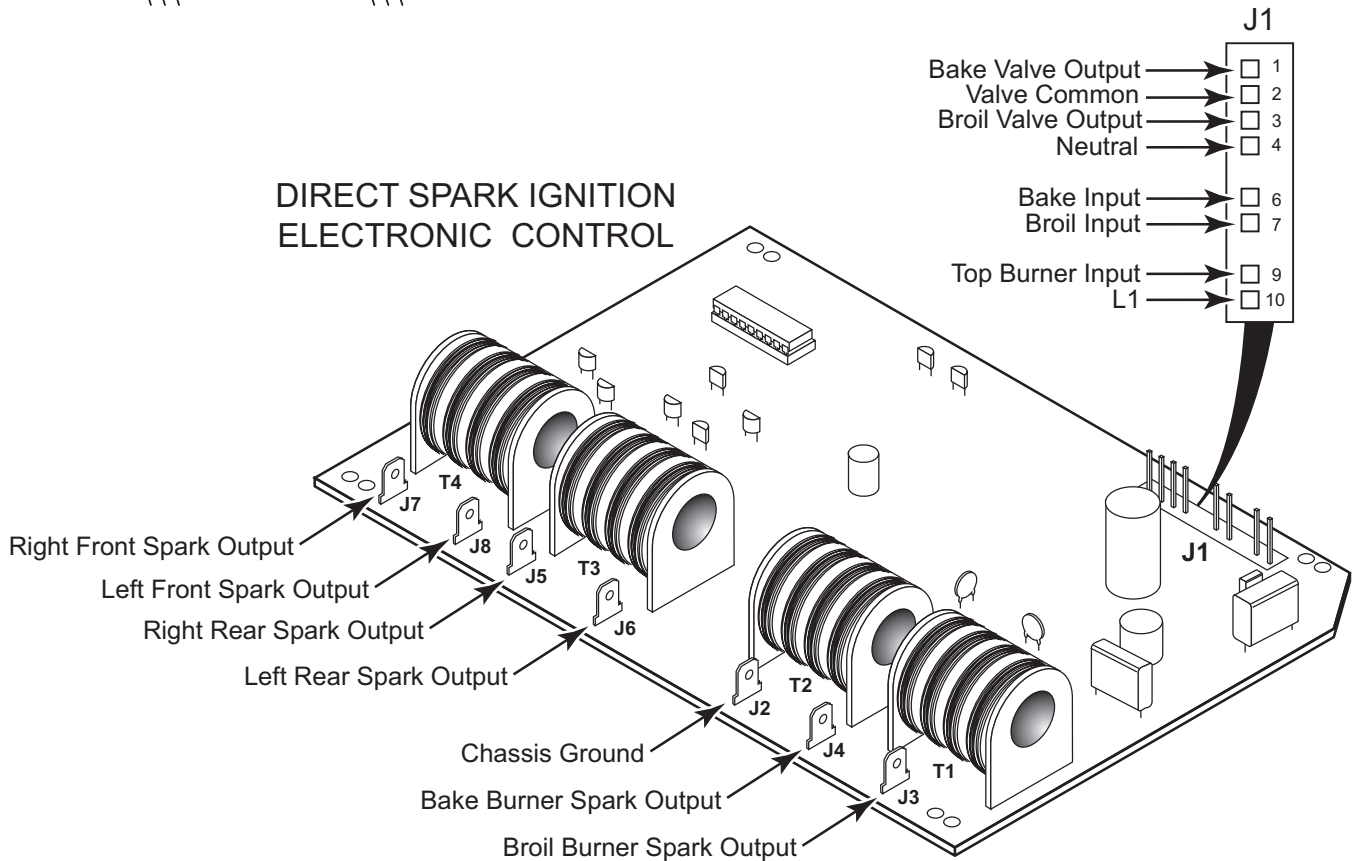
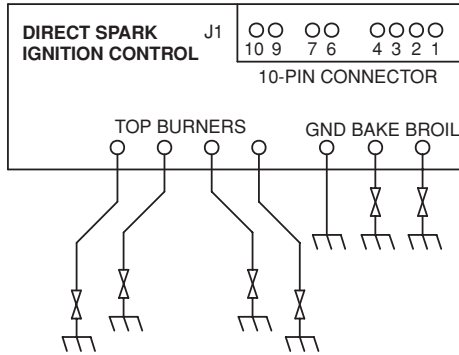

ELECTRONIC SPARK IGNITION

COOKTOP BURNER OPERATION

The top burner spark ignition system is initiated when the burner control is turned to the LITE position.

120 VAC is supplied through the ignition switch from the L1 side of the circuit to the direct spark ignition control at input J1-9 on the control. The circuit is completed through output pin J1-4 to the neutral side of the circuit.

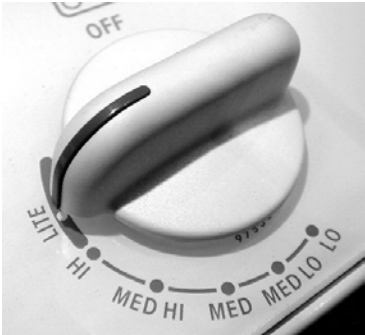

This 120 VAC is detected by the control, and generates two sparks-per-second to all of the top burners. Note that in the strip circuit below, 120 VAC is present at the control at all times through input pin J1-10, and output pin J1-4.

120 VAC is required to:

- Monitor the internal self-diagnostics of the control board.
- Monitor the flame safety circuits to both of the oven burners.

NOTE: The top burners are operator-monitored, and do not require electronic monitoring.

Cooktop Strip Circuit

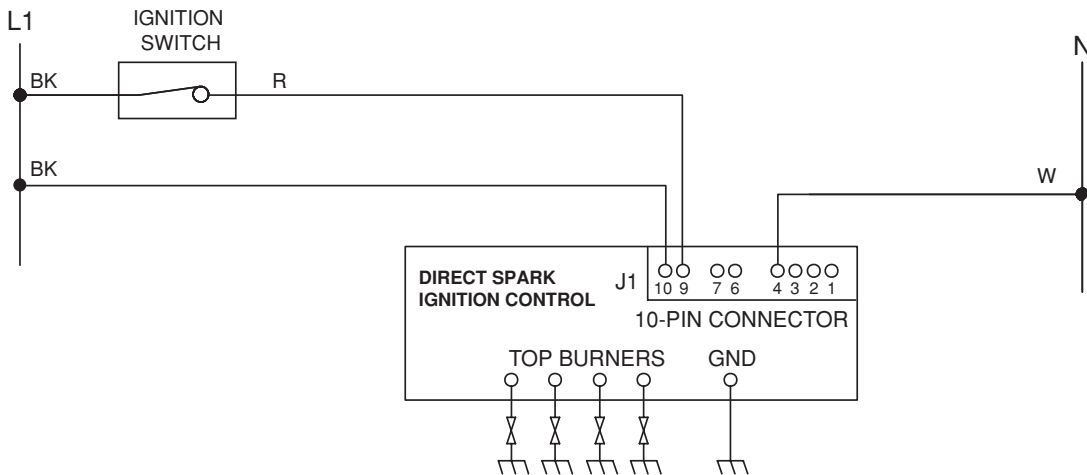

OVEN BURNER OPERATION

The spark ignition for the oven burners is started at the Electronic Oven Control (ERC). As the ERC is programmed for Bake or Broil, the appropriate relay is closed on the ERC. 120 VAC is provided from L1, through the ERC relay(s) to the direct spark ignition control at input pin J1-6 (Bake), or J1-7 (Broil), to the neutral side of the circuit, through output pin J1-4.

This 120 VAC is used to generate two sparks-per-second to both oven burners. The 120 volts AC is also stepped-down to between 8 and 18 VDC through pins J1-1 and J1-2 (Bake), and pins J1-3 and J1-2 (Broil). This DC voltage opens the gas distribution valve, and provides gas to the appropriate oven burner.

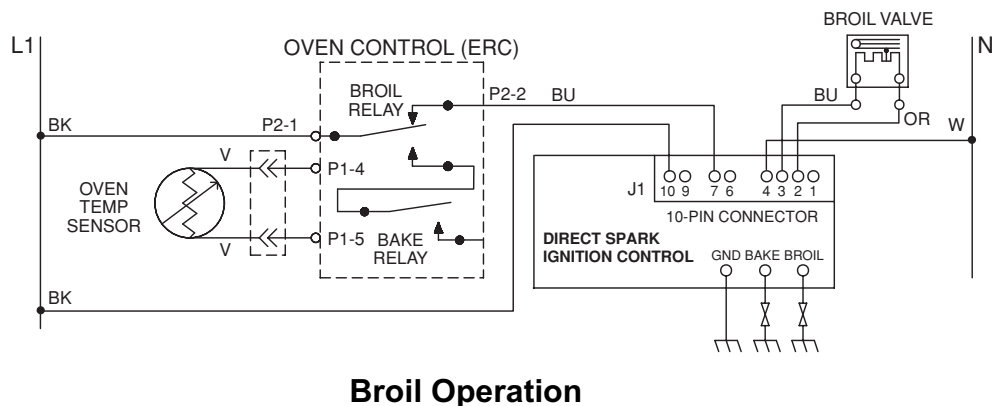
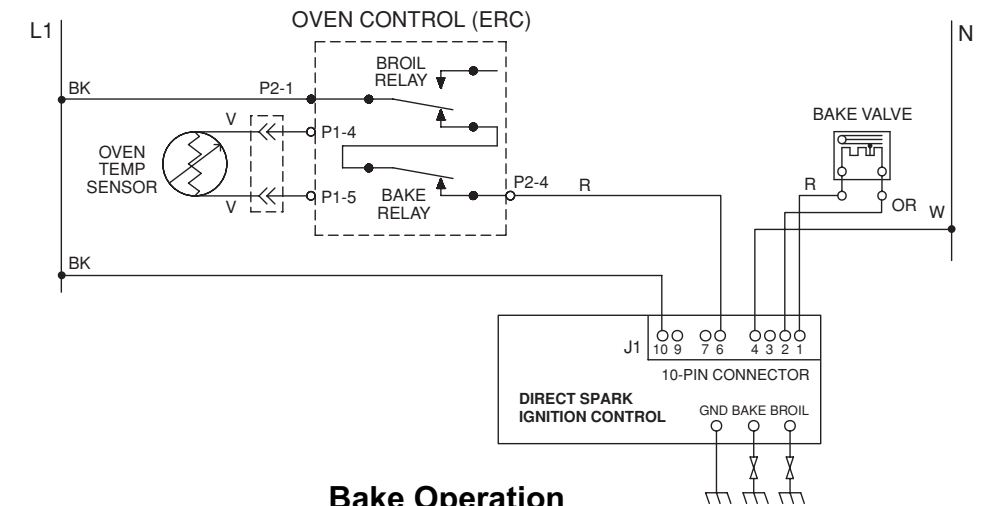

Monitoring System

When power is applied to the range, a safety delay of 40 seconds takes place before the direct spark ignition control becomes operational. The 40 second delay allows any unused gas inside the oven cavity to dissipate before a spark is activated. When the Bake or Broil operation is activated, the direct spark ignition control initiates an "internal self-test" and "flame safety check." The flame safety check takes place anytime there is a flame present at either oven burner.

The self-test checks both solenoids on the gas distribution valve to verify that they are properly connected. If they are not, the control will turn the oven off, or lock it out. If the test is successful, the control will then open the appropriate valve, and initiate sparking at the burner ignitor. Both the bake and broil ignitors spark simultaneously. Sparking will not occur until the gas distribution valve opens.

Once the gas has ignited, the “flame safety circuit” will monitor the flame at the burner to make sure it is present. If a flame is not present at the burner:

- a) The control will allow the ignitor to spark for 4 seconds.
- b) A 40 second delay to dissipate any unused gas inside the oven will occur.

The ignition attempt will occur three times. If the burner does not ignite after the three attempts, the system will “lockout” (see the Timing Chart below).

Lockout

The control will perform an oven system lockout if:

- a) Any of the self-test checks fail.
- b) The oven fails to ignite after three ignition attempts.

- c) A flame is present within the oven for more than 10 seconds after the gas valve is off.
- d) The flame is unexpectedly lost for any reason after being established. NOTE: If this occurs, a lockout condition will occur after 30 seconds with no attempt to reignite.

During the lockout, the gas distribution valve and ignition are turned off. All lockouts can be reset by pressing the OFF/Cancel keypad on the Electronic Oven Control. NOTE: There will be no indication on the electronic oven control display showing a lockout condition.

Note To Technician: The cooktop spark operates normally even when the oven is in the “lockout” mode. If the oven does not appear to work at all, verify the operation of the cooktop spark. If the cooktop spark is working correctly, the DSI control is most likely okay, and the problem is somewhere else in the range.

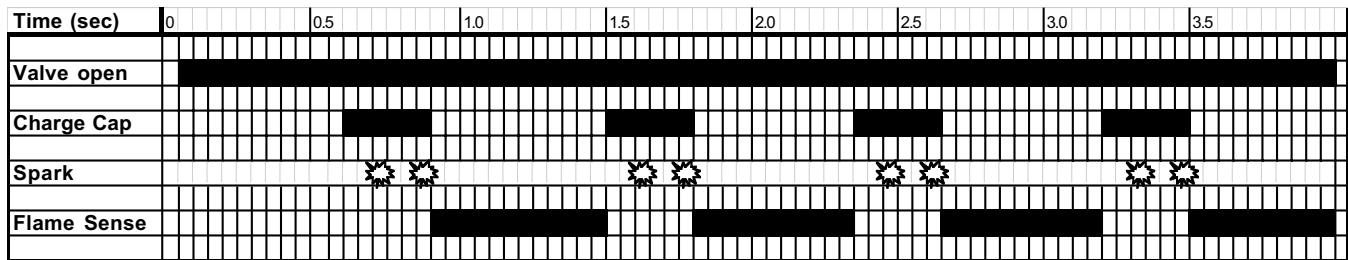

**Timing Chart (Oven Burners)
Timing Sequence = 4 Seconds
3 Attempts Before Lockout**

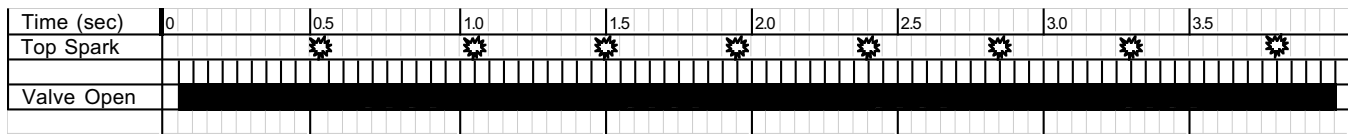

Timing Chart (Cooktop Burners)

SECTION 2

COMPONENT ACCESS

This section instructs you on how to service the direct spark ignition system components inside the Gas Range.

REMOVING THE DIRECT SPARK IGNITION CONTROL

! WARNING

ELECTRICAL SHOCK HAZARD

Disconnect power before servicing the range.
Replace all panels before operating range.
Failure to do so can result in death or electrical shock.

FIRE HAZARD

Shut off gas supply line valve before servicing the range.
Check all gas line connections and replace all panels before operating the range.
Failure to do so could result in explosion, fire, or other injury.

CAUTION: When you work on the gas range, be careful when handling the sheet metal parts. Sharp edges may be present, and you can cut yourself if you are not careful.

1. Turn off the gas to the range and disconnect the power cord from the wall outlet.
2. Pull the range away from the wall so you can access the back of the unit.
3. Remove the top rear cover (4 screws).

Screw (1 of 4) Top Rear Cover



4. Disconnect the wire connectors from the direct spark ignition control.

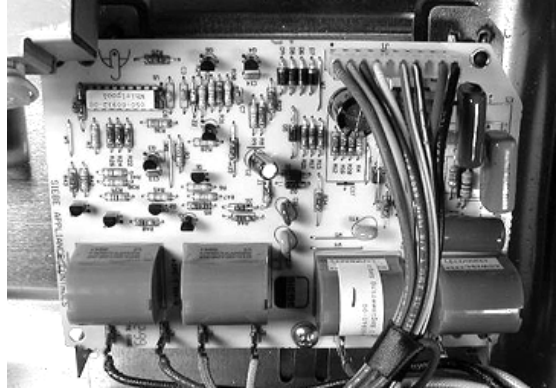

5. Remove the mounting screws.
6. Slide the two top pins out of the bracket slots and remove the control from the bracket.

Board Pin In Slot

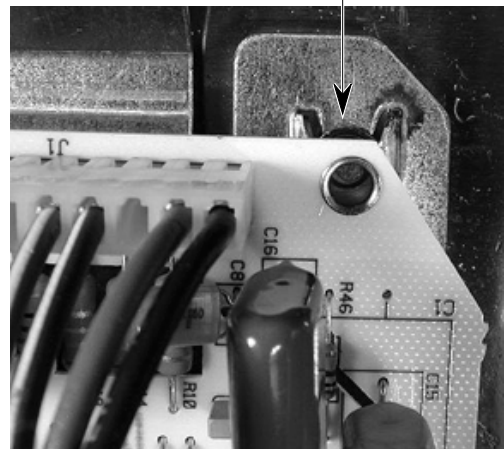

REMOVING THE GAS DISTRIBUTION VALVE

! WARNING

ELECTRICAL SHOCK HAZARD

Disconnect power before servicing the range.
Replace all panels before operating range.
Failure to do so can result in death or electrical shock.

FIRE HAZARD

Shut off gas supply line valve before servicing the range.
Check all gas line connections and replace all panels before operating the range.
Failure to do so could result in explosion, fire, or other injury.

CAUTION: When you work on the gas range, be careful when handling the sheet metal parts. Sharp edges may be present, and you can cut yourself if you are not careful.

1. Turn off the gas to the range and disconnect the power cord from the wall outlet.
2. Pull the range away from the wall so you can access the back of the unit.

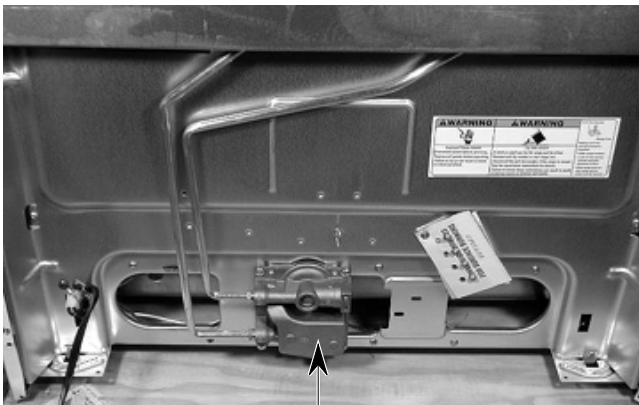

**Gas Distribution Valve
(Back of Range)**

3. Remove the gas outlet lines from the gas distribution valve with a 9/16" open-end wrench.
4. Remove the four mounting screws from the gas distribution valve.

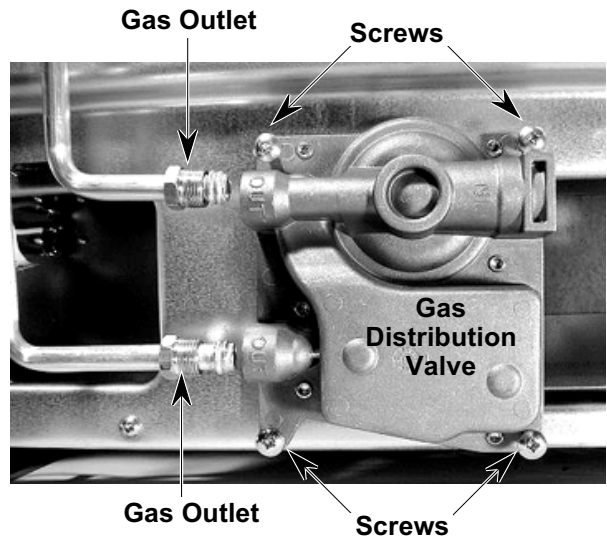

5. Lower the gas distribution valve so that it is free of the bake burner, and lay it down, as shown below.

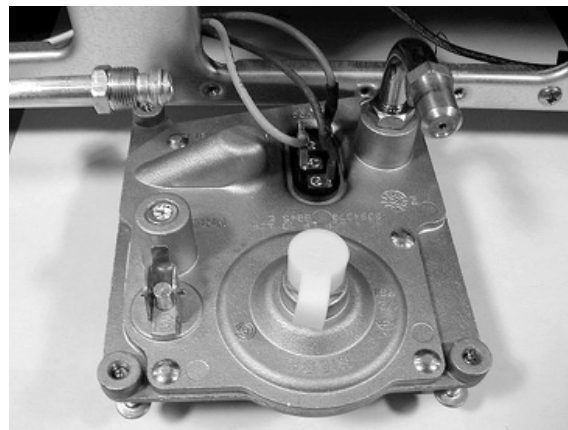

6. Remove the electrical connections. **NOTE:** The terminals are different sizes to prevent miswiring (see page 4).

SECTION 3

COMPONENT TESTING

DIRECT SPARK IGNITION CONTROL

! WARNING

Electrical Shock Hazard
Voltage is present during these tests.

TEST PROCEDURE

Voltage Tests

Bake Function

1. Set the voltmeter to read 120 VAC.
2. Program the range for the Bake operation.

J1 Connector

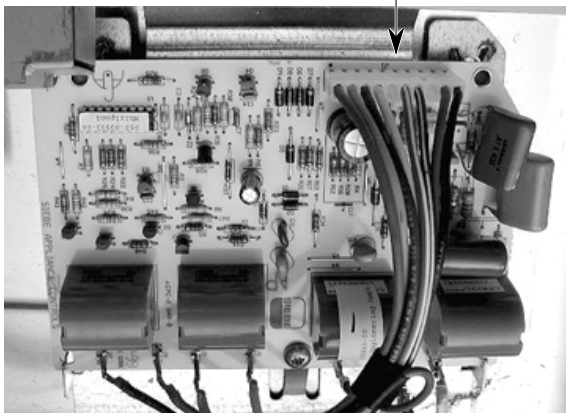

3. If the top burners spark, proceed to step 4. Touch the test leads to the J1 connector at terminals 4 (white) and 10 (black). The AC voltmeter should indicate 120 VAC. If not, check for the proper voltage at the power supply outlet, and check the main wiring harness.

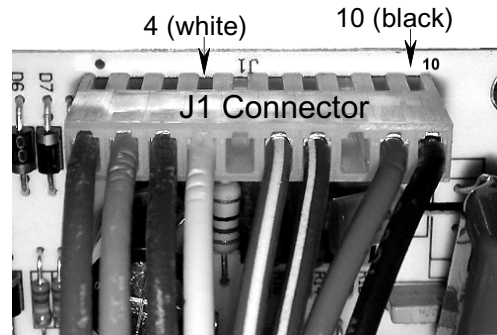

4. Touch the test leads to the J1 connector at terminals 4 (white) and 6 (red/white). The AC voltmeter should indicate 120 VAC. If not, check the electronic oven control for proper operation.

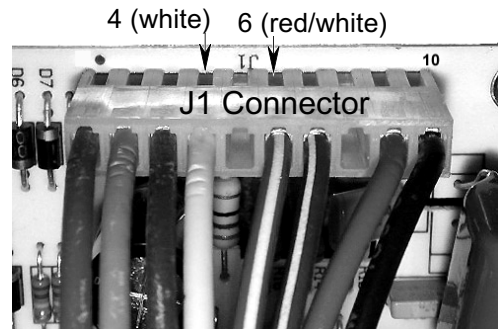

Bake Strip Circuit

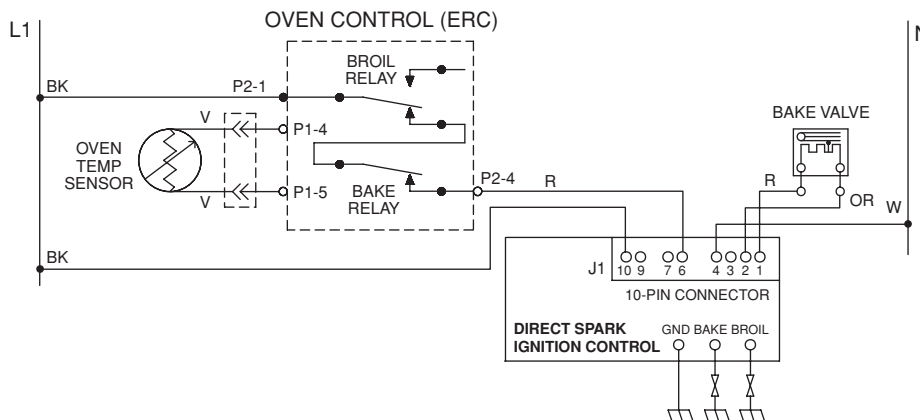

5. Set the voltmeter to read between 8 and 18 volts DC.
6. Touch the test leads to the J1 connector at terminals 1 (red) and 2 (orange). The DC voltmeter should indicate between 8 and 18 volts DC*. If not, replace the DSI control.

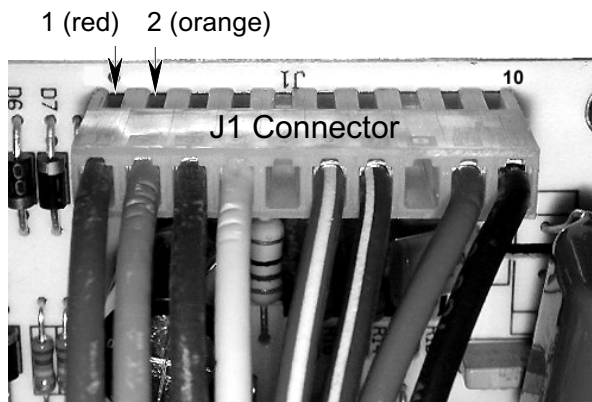

* When power is applied to the range, a safety delay of 40 seconds takes place before the direct spark ignition control becomes operational. The operation will last for a period of 4 seconds, and the direct spark ignition will again turn off (see the "Timing Chart" for the oven burners on page 10).

Broil Function

1. Set the voltmeter to read 120 VAC.
2. Program the range for the Broil operation.

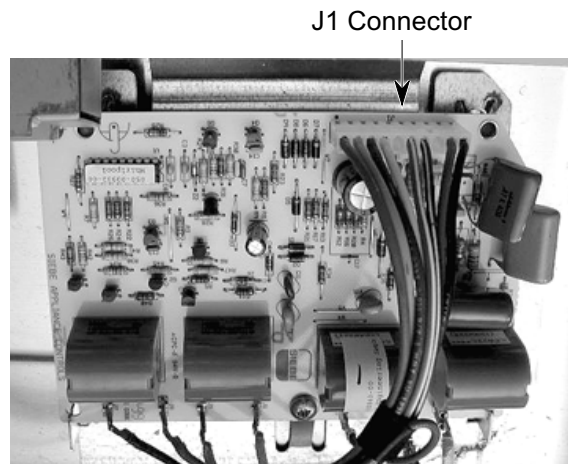

3. If the top burners spark, proceed to step 4. Touch the test leads to the J1 connector at terminals 4 (white) and 10 (black). The AC voltmeter should indicate 120 VAC. If not, check for the proper voltage at the power supply outlet, and check the main wiring harness.

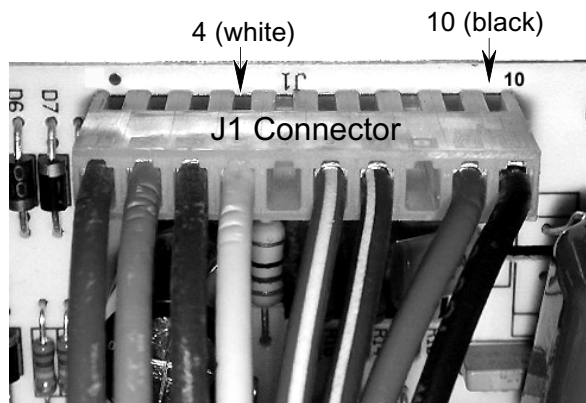

- Touch the test leads to the J1 connector at terminals 4 (white) and 7 (blue/white). The AC voltmeter should indicate 120 VAC. If not, check the electronic oven control for proper operation.

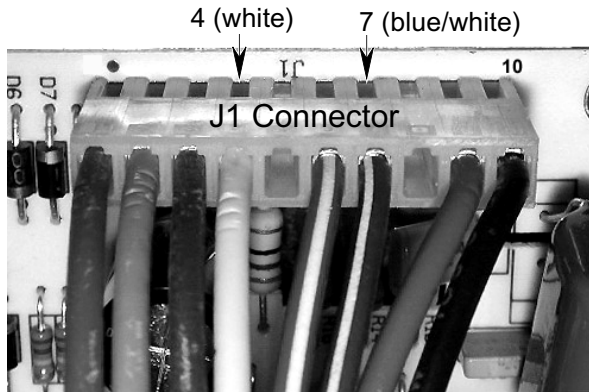

- Touch the test leads to the J1 connector at terminals 2 (orange) and 3 (blue). The DC voltmeter should indicate between 8 and 18 volts DC*. If not, replace the DSI control.

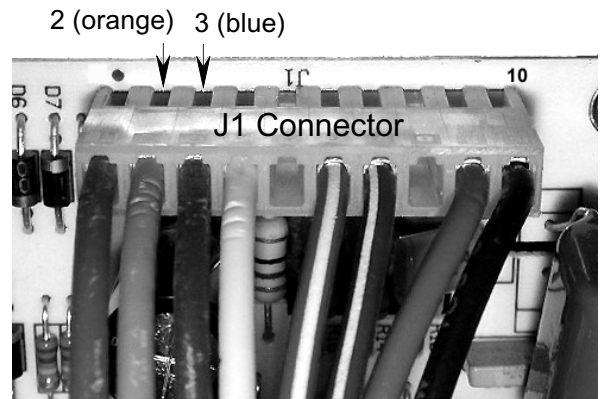

- Set the voltmeter to read between 8 and 18 volts DC.

* When power is applied to the range, a safety delay of 40 seconds takes place before the direct spark ignition control becomes operational. The operation will last for a period of 4 seconds, and the direct spark ignition will again turn off (see the "Timing Chart" for the oven burners on page 10).

Broil Strip Circuit

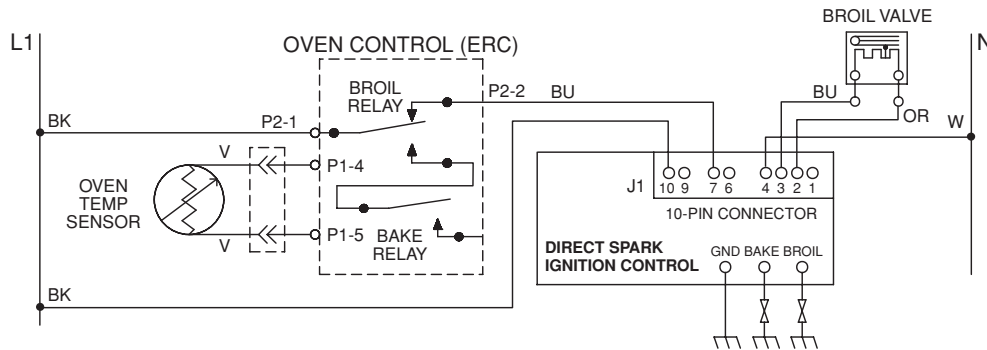

Cooktop Function

1. Set the voltmeter to read 120 VAC.

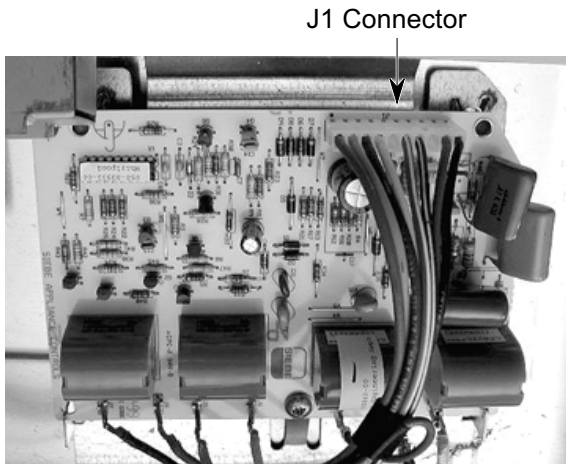

2. Turn one of the cooktop burner valves to the LITE position.

3. Touch the test leads to the J1 connector at terminals 4 (white) and 10 (black). The AC voltmeter should indicate 120 VAC. If not, check for the proper voltage at the power supply outlet, and check the main wiring harness.

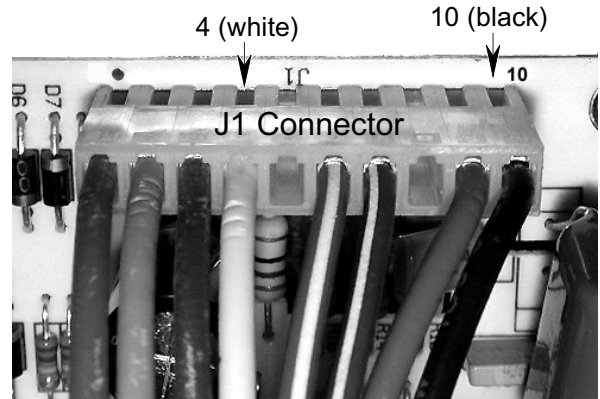

4. Touch the test leads to the J1 connector at terminals 4 (white) and 9 (red). The AC voltmeter should indicate 120 VAC. If not, check the ignition switch and the main wiring harness.

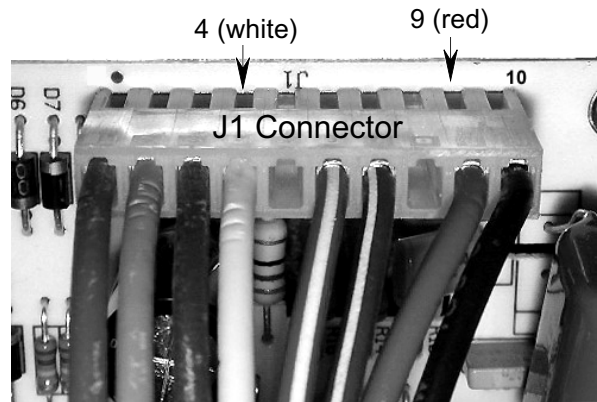

Cooktop Strip Circuit

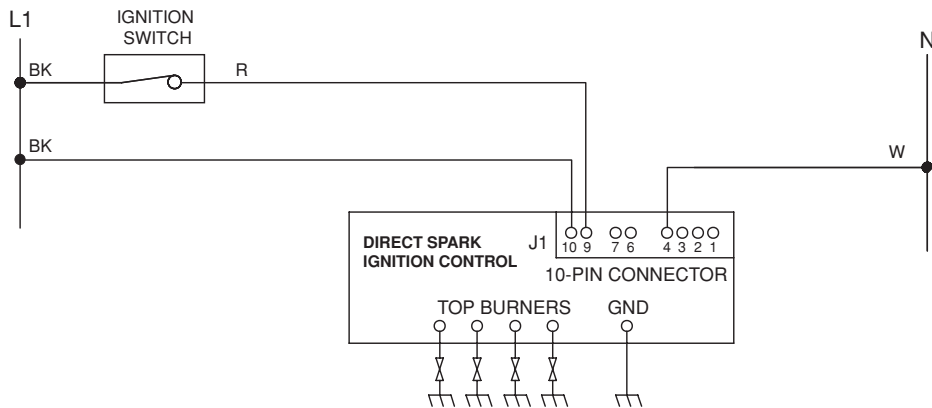

GAS DISTRIBUTION VALVE

TEST PROCEDURE

Solenoid Resistance Tests

1. Disconnect power from the range.
2. Set the ohmmeter to the R x 100 scale.
3. Touch the ohmmeter terminals to terminals 1 and 2 (Broil). The ohmmeter should read $216 \Omega \pm 30$.
4. Touch the ohmmeter terminals to terminals 3 and 2 (Bake). The ohmmeter should read $216 \Omega \pm 30$.

NOTE: Always check both solenoids. If one of the solenoids is defective, neither one will operate.

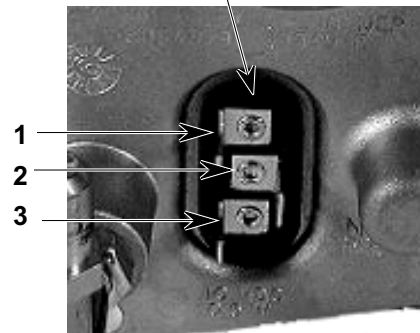

— NOTES —

SECTION 4

WIRING DIAGRAM & STRIP CIRCUITS

WIRING DIAGRAM

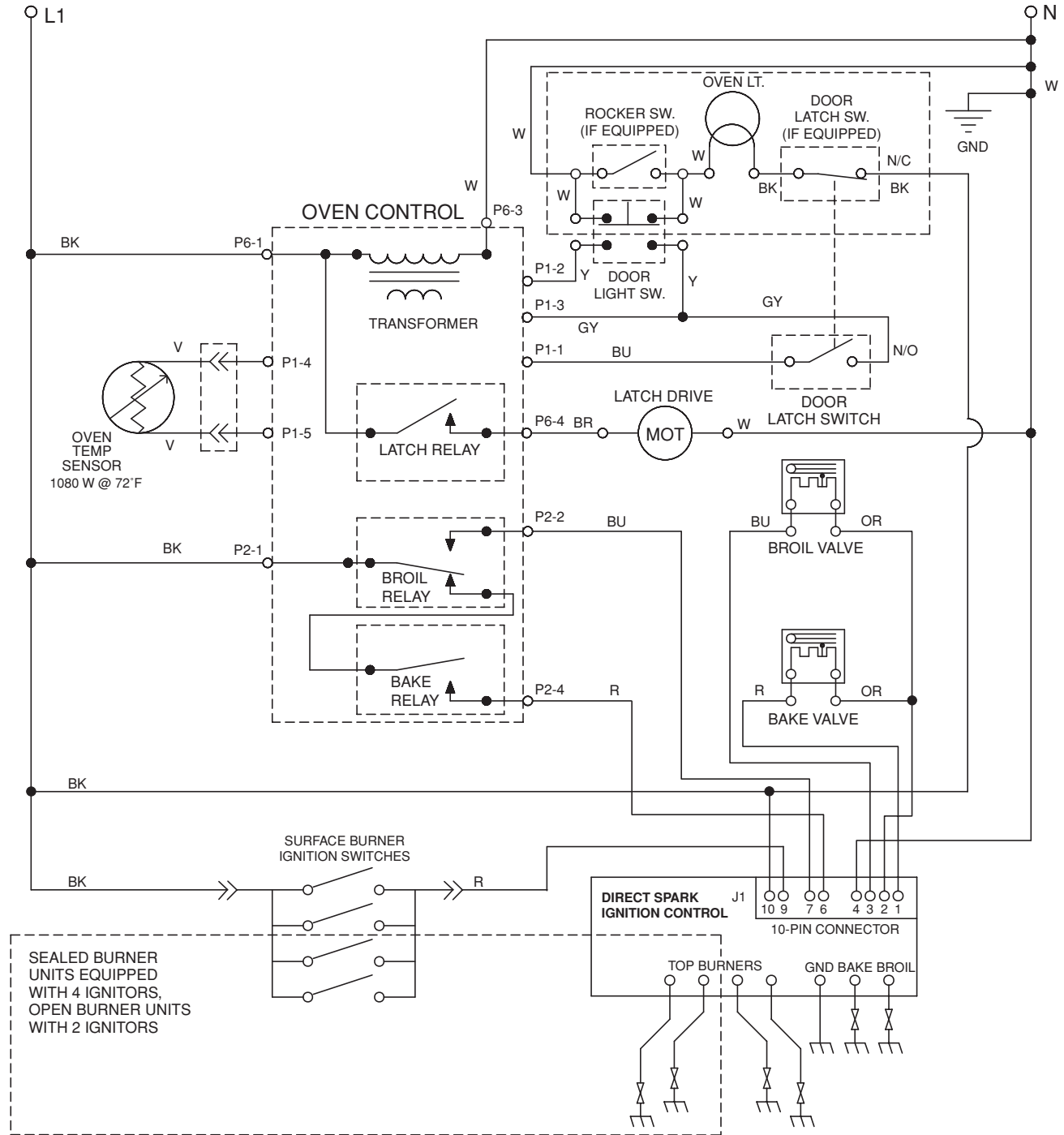

NOTE: Drawing shows door latch switch in the Cook position with oven door open, oven Off, and light On.

PART NO. 8273173

STRIP CIRCUITS

BAKE

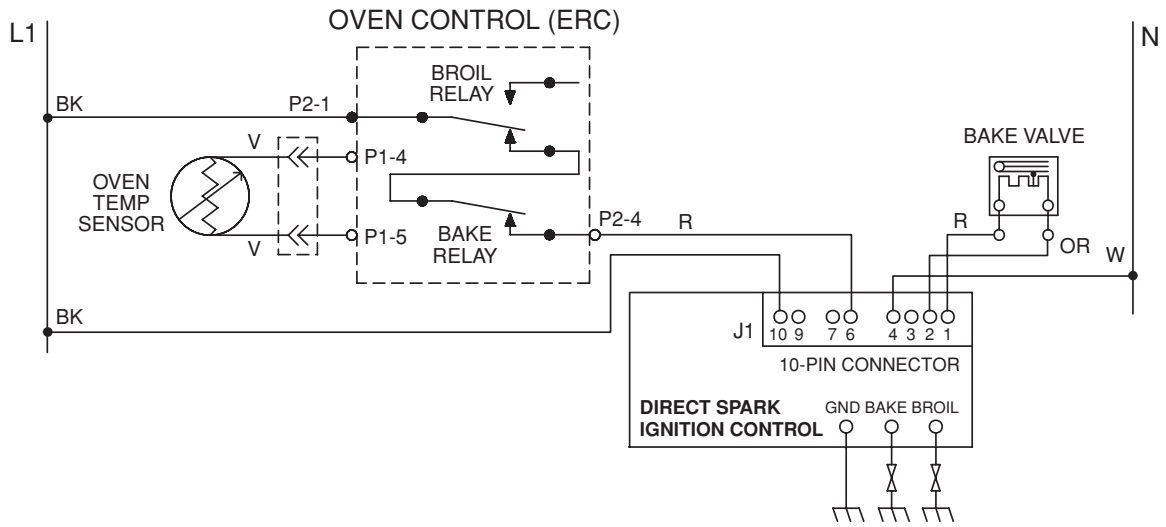

BROIL

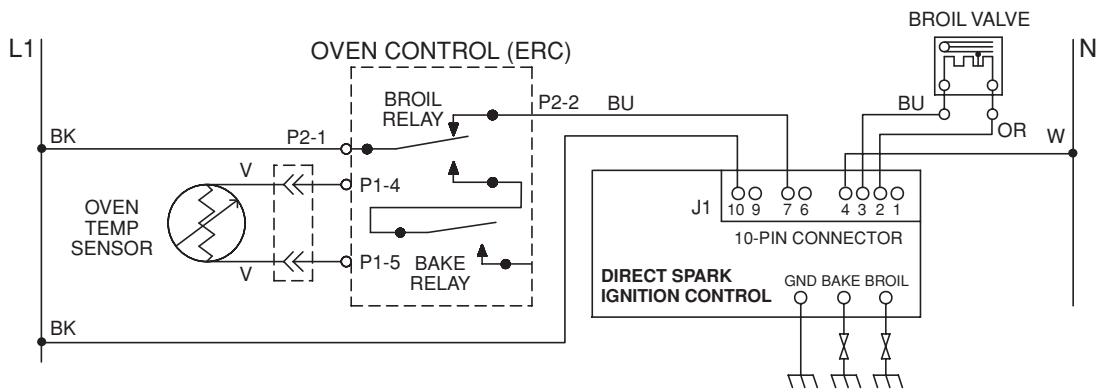

COOKTOP

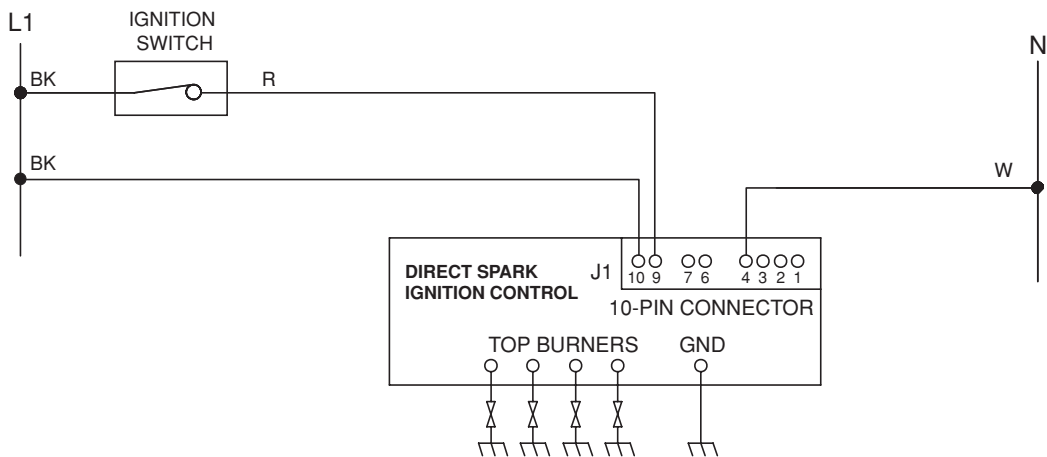

CLEAN

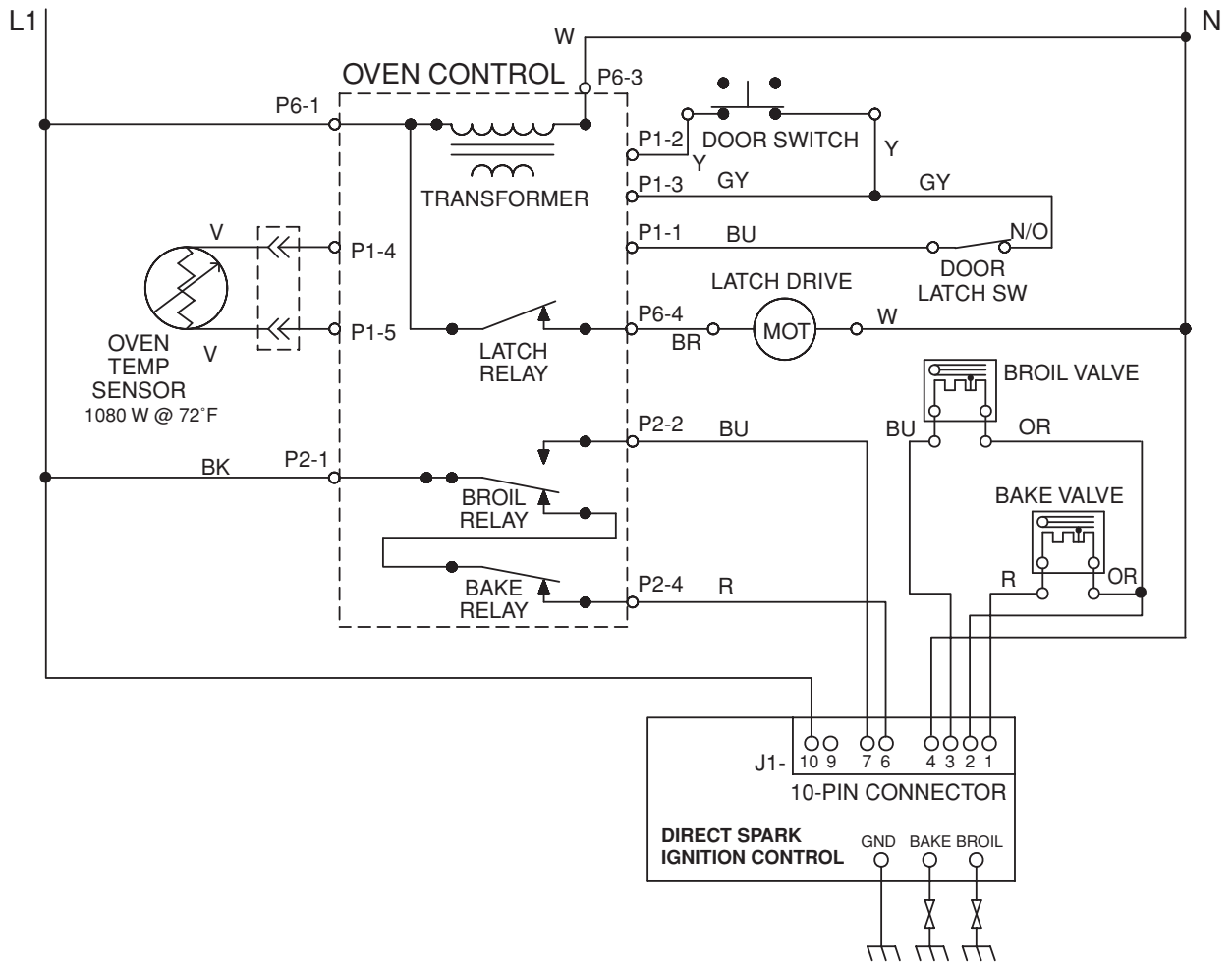

— NOTES —

SECTION 5

TECH TIPS

DIAGNOSTIC FLOW CHARTS

COOKTOP

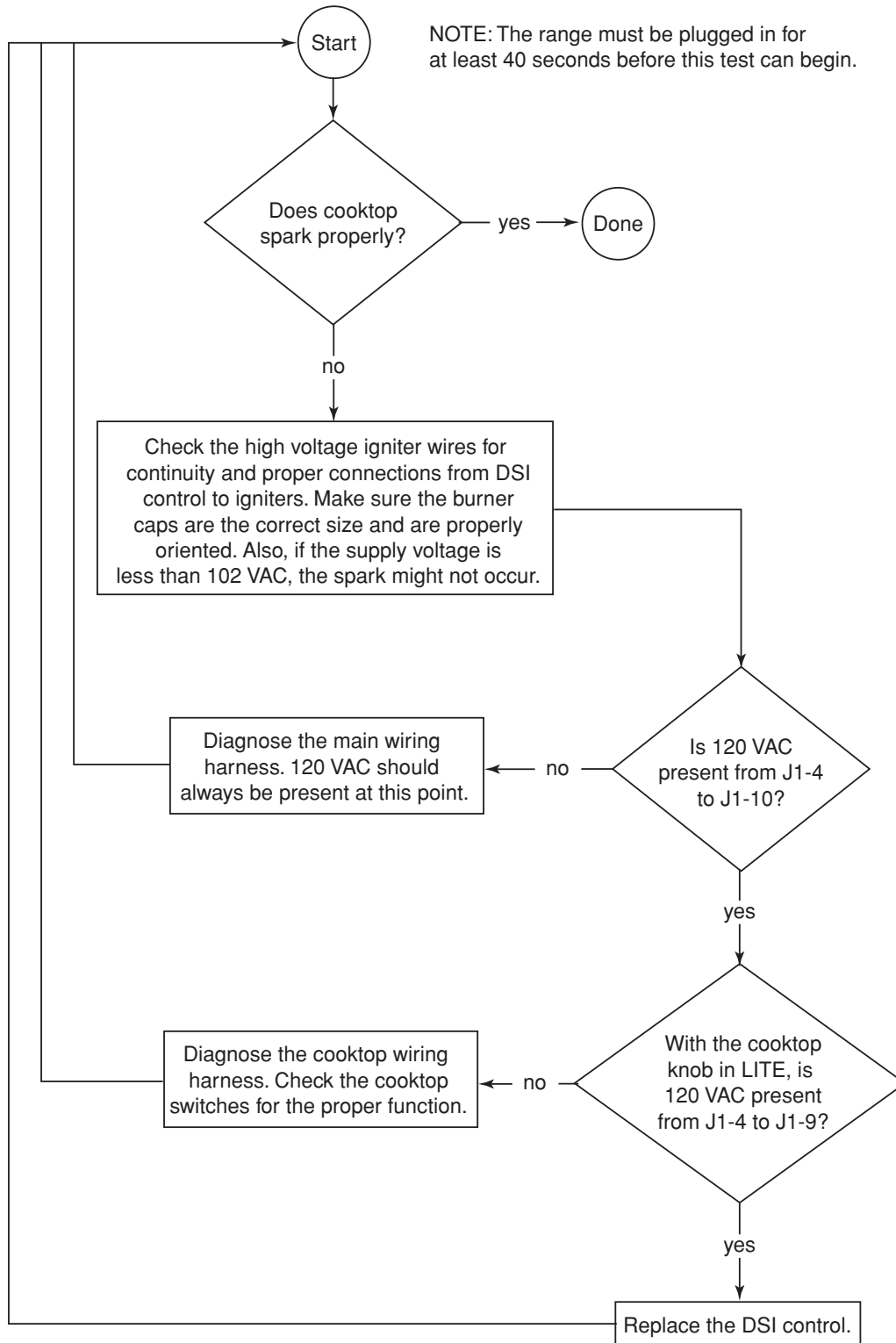

BAKE

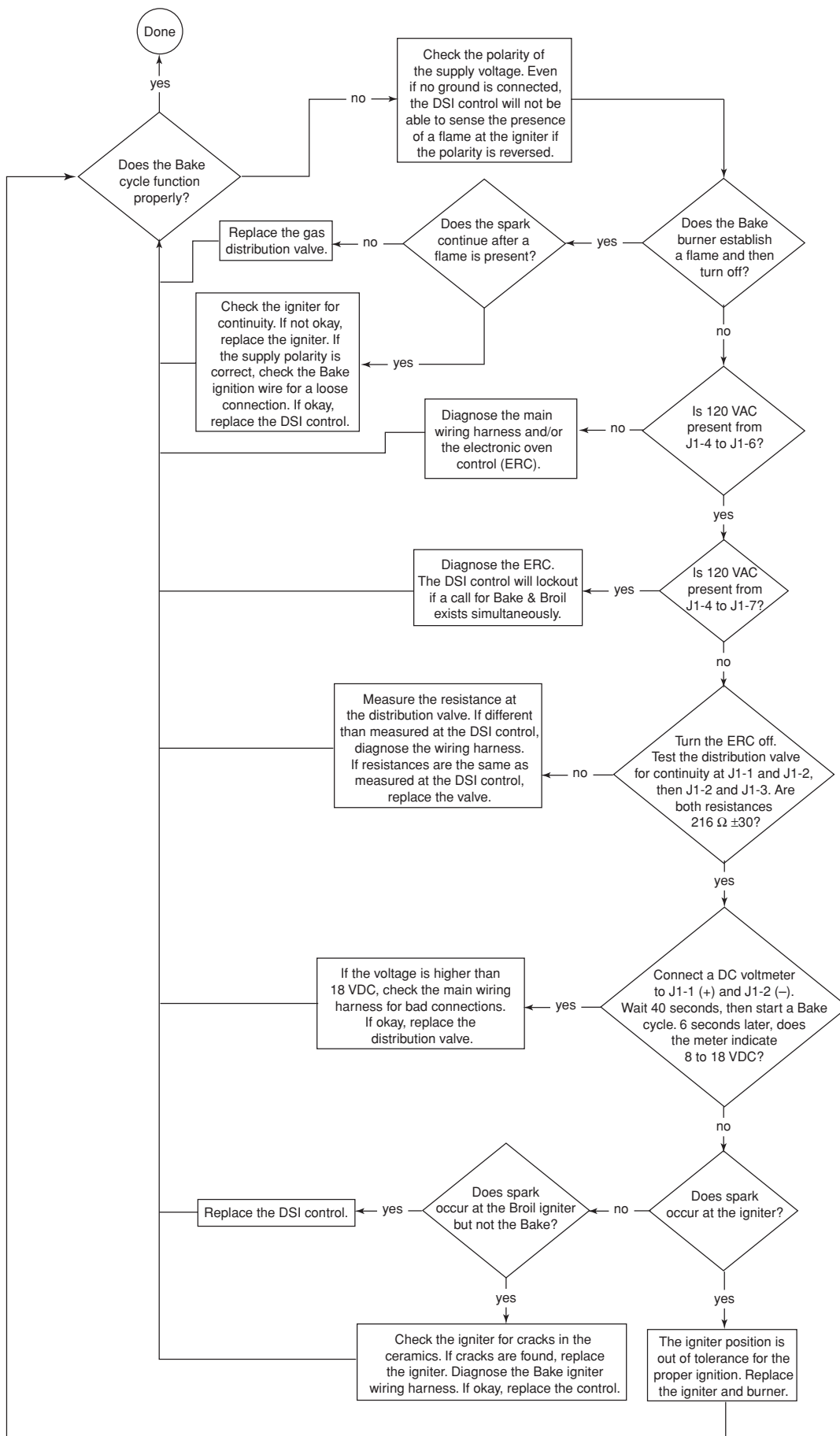

BROIL

