

**Upgraded Biofuels - Effects of Quality  
on Processing, Handling  
Characteristics, Combustion and Ash  
melting**

**Susanne Paulrud**

*Unit of Biomass Technology and Chemistry  
Umeå*

**Doctoral thesis  
Swedish University of Agricultural Sciences  
Umeå 2004**

**Acta Universitatis Agriculturae Sueciae**  
Agraria 449

ISSN 1401-6249  
ISBN 91-576-6459-5  
© 2004 Susanne Paulrud, Umeå  
Printed by: SLU, Grafiska Enheten, Umeå 2004

## Abstract

Paulrud, S. 2004. *Upgraded Biofuels-Effects of Quality on Processing, Handling Characteristics, Combustion and Ash Melting*. Doctoral dissertation. ISBN 91-576-6459-5, ISSN 1401-6249

Processing (upgrading) to dry and uniform fuels (briquettes, pellets, and powder) extend the use of biomass wastes as an energy source. Upgrading decreases transportation costs, increases storage capacity, and improves combustion properties. The intention of the present work was to investigate the effect of chemical characteristics and physical characteristics on processing, handling characteristics, combustion, and ash melting, using upgraded biofuels. The raw materials used was spring-harvested reed canary-grass (RCG) and wood residues (stemwood without bark).

RCG with different ash contents was upgraded to briquettes and combustion experiments were done in a 180 kW boiler. RCG was found to be a suitable raw material for briquetting and variation in ash content did not affect the briquette quality. Combustion experiments showed that RCG can be burned with good result and the variation in ash content did not effect flue gas emissions. The ash formed during combustion showed a tendency to melt. Estimation of melting behaviour was done by ASTM fusion test, a bench scale fluidised-bed combustion test (5 kW), and by extracting melting behaviours from the ternary diagram  $\text{SiO}_2\text{-CaO-K}_2\text{O}$ . For RCG with low ash content (3-4%), the tendency to melt was higher compared to RCG with high ash content (5-10%). Wood powder cut in various impact mills and knife mills was characterised using sieve analysis, laser diffraction, image analysis, and a funnel method for measuring the tendency to bridge. The wood powder fuels were then combusted in a 150 kW powder burner to study emissions as a function of particle properties. Sieving and image analysis showed that impact mills produced wood powder with more fine particles than wood powder produced by knife mills. Image analysis showed that particle shapes differed between the two types of mills. The bridging tendency was higher for powder produced by impact mills than by knife mills. Combustion experiments showed that particle characteristics affected fuel feeding, ignition, unburned pollutants, furnace temperature, and content of unburned matter in ash. An increased content of smaller particles had a negative effect on fuel feeding and NO emissions were slightly increased while it had a positive effect on ignition, unburned pollutants (decreased) and content unburned matter (decreased).

*Keywords:* Piston press, CO emissions, PCA, PLS.

*Author's address:* Susanne Paulrud, Unit of Biomass Technology and Chemistry, Swedish University of Agricultural Sciences, P.O. Box 4097, SE-904 03 Umeå, Sweden. E-mail: susanne.paulrud@btk.slu.se



# Contents

**Introduction, 7**

**Use of upgraded biofuels in Sweden, 8**

**Raw material, 10**

Wood residues, 10

Agricultural residues, 11

**Processing, 14**

Briquettes, 15

Pellets, 17

Fuel powder, 17

**Combustion Technology, 18**

Boilers, 19

Pre-furnaces, 20

Pellets burners, 20

Powder burners, 21

**Fuel quality, 24**

Chemical characteristics, 24

*Methods for chemical analyses of fuels and ash, 25*

*Effects on emissions, 27*

*Effects on ash melting, 28*

*Prediction of ash melting behaviour, 30*

Physical characteristics, 36

*Characterisation methods, 36*

*Effects of fuel characteristics on handling properties, 43*

*Effects of fuel characteristics on emissions during combustion, 44*

**Experimental design and data analysis, 46**

**Conclusions and future research, 47**

**Acknowledgements, 48**

**References, 49**

# Appendix

## List of original papers

This thesis is based on the following papers, which are referred to in the text by their respective Roman numerals

- I. Paulrud, S. & Nilsson, C. 2001. Briquetting and combustion of spring-harvested reed canary-grass: effect of fuel composition. *Biomass and Bioenergy* 20, 25-35.
- II. Paulrud, S., Nilsson, C. & Öhman, M. 2001. Reed canary-grass ash composition and its melting behaviour during combustion. *Fuel* 80, 1391-1398.
- III. Paulrud, S., Mattsson, JE. & Nilsson, C. 2002. Particle and handling characteristics of wood fuel powder: effects of different mills. *Fuel Processing Technology* 76, 23-39.
- IV. Paulrud, S. & Nilsson, C. 2004. The effects of particle characteristics on emissions from burning wood fuel powder. *Fuel* 83, 813-821.

The papers are reproduced by permission of the journals concerned.

## Introduction

The combustion of cultivated and residue solid biomass fuels can decrease emissions of fossil CO<sub>2</sub>. In order to meet an increasing energy demand, alternative energy sources like biomass must be used effectively. One solution is to upgrade biomass to dry and uniform fuel briquettes, fuel pellets, and fuel powder because these fuels are easier to handle and combust than unrefined fuels. They cost less to transport and store, and they have higher combustion efficiency. In addition, these fuels can be used in retrofitted fossil fuel boilers and used in co-combustion in existing firing systems such as coal-firing power stations.

In Sweden, upgraded biofuels (densified fuels and powder fuels) are mainly produced with raw material with low ash content such as sawdust and shavings from saw mills and the wood working industry. However, over the last five years, the use of upgraded fuels has increased so fast that other raw materials such as peat, bark, and energy crops are attracting increased interest (Rietz, 2002).

Spring-harvested reed canary-grass (RCG) is one promising bioenergy crop. The perennial grass is harvested during the spring before the new growth starts instead of autumn, giving a dry (85% dry matter content) and storable material that can be directly briquetted, pelletised, or pulverised after disintegration without any artificial drying. The chemical composition of spring harvested RCG differs from wood fuels and the composition varies depending on soil type (Landström, Lomakka, & Andersson, 1996; Burvall, 1997). Reed canary-grass demonstrates higher levels for elements such as Cl, S, and N, and for ash forming elements RCG usually shows higher levels of Si, K, Ca, and P (Burvall, 1997; Paper I). Fuel composition is most important since it influences combustion behaviour. An increased use of energy crops like RCG requires studies of potential problems associated with this new fuel. A higher content of elements like S, N, and Cl might increase undesired emissions and ash forming elements might cause ash related problems during combustion such as deposit formations in the boiler and convection area.

In Sweden, a large amount, approximately 60%, of the upgraded fuels produced is combusted as powder in large-scale combustion plants for district heating (Svenska Trädbänsleforeningen, 2002). The fuel is directly delivered as powder or delivered as pellets and milled before combustion. The type of mill and sieve that produces pulverised fuel influences particle size, particle shape, and size distribution. These properties affect the handling properties of powders such as the tendency to bridge and flow in transport and storage systems. Furthermore, these parameters influence efficiency and emission levels when burning fuel powder. There are several studies on the influence of particle properties on handling characteristics such as bridging (Mattsson, 1990, 1997; Mattsson & Kofman, 2003; Paper III) and on formation of emissions during powder combustion (Reuther, Karsner & Jack, 1982; Duxbury & Welford, 1989; Abbas, et al., 1994; Van der Lans, Glarborg & Dam-Johansen, 1997; Paper IV). However, in most studies finely milled, coarsely milled, or blends were used and little is reported concerning the effects by using powder from different types of mills.

This study aims to increase the understanding of how spring-harvested reed canary-grass briquettes with different chemical composition influence the briquetting process and influence emissions using a 180 kW compact boiler (Paper I). Furthermore, this study aims to increase our knowledge of the ash melting behaviour of these spring harvested reed canary-grass fuels during combustion (Paper II).

This study uses sieving, laser diffraction particle size analysis, and image analysis to characterise wood powder from different mills. In addition, this study uses a new funnel method to examine the relationship among particle characteristics, tendency to bridge, and type of mill (Paper III). Powder fuels were also combusted in a 150 kW swirl powder burner to study emissions as a function of particle properties (Paper IV).

## **Use of upgraded biofuels in Sweden**

Biomass wastes such as sawdust, shavings, bark, and agro-residues can be dried, milled, and compacted into fuel briquettes, fuel pellets, or finely milled to fuel powder (Figure 1). Briquettes are compressed raw material usually with a circular diameter minimum of 25 mm (SS 187123). A fuel pellet is a small cylinder of compressed finely ground materials with a diameter maximum of 25 mm (SS187120). On the Swedish market, the diameter of briquettes are usually 70 mm to 90 mm and the pellet diameter is between 6 mm and 12 mm. Fuel powder is a dry finely milled material where the size distribution is not standardised. The producers make powder according to the user's request. Usually the combustion plants request a smaller particle size during the warmer seasons when the boiler is operated at lower effect. The size is usually defined as the weight-% material that are larger or smaller than the diameter of a sieve size; for example, 95% of the material is smaller than 1 mm and 50% is smaller than 0.5 mm. Thus, a quite rough definition.

In Sweden, biomass processing started as mean to solve the problems associated with large volumes of wastes from wood processing industries, but upgrading to dry and uniform fuels extended the use of biomass wastes as an energy source. Because wood wastes and agricultural residues are voluminous with low density and generally produced locally, they are uneconomical to transport; therefore, the wastes can only be used in local power stations. Processing wastes into dry uniform fuels decreases transportation costs (Vinterbäck & Hillring, 1998), increases storage capacity (Lehtikangas, 2000), increases energy density, and improves combustion properties (Olsson, 2002).

In Sweden, densified wood fuels dates back to the early 1900s when briquetting was put into practice in some large saw mills (Vinterbäck, 2000). However, the production and use was still very small until the global oil crises in the 1970s when the interest and use of upgraded biofuels started to increase. Large-scale plants for briquette and powder production were built in the 1970s, and by the beginning of 1980s the first wood pellet plant was built. In the early 1990s, the Swedish government taxed mineral fuels and biomass became the most profitable



fuel, encouraging the rapid growth of upgraded biofuels. In 2001, 5.1 TWh of briquettes, pellets, and powder were produced. Pellets were the main part, 70% of the total production of upgraded biofuels, and briquette and powder production was 15% respectively (Svenska Trädbränsleförbundet, 2002).



*Figure 1.* Fuel powder, fuel briquettes, and fuel pellets.

Three main groups of energy producers use upgraded biofuels: Large-scale commercial heating plants (>2 MW), medium sized boilers, mostly in block centrals, and the residential heating market. Initially, mainly large-scale and medium-sized plants used upgraded biofuels, but pellets have now rapidly expanded into the residential heating market. Today approximately 20% of pellet production is used for residential heating (Olsson, 2002).

Large-scale combustion plants mainly use powder burners, and the fuel is directly delivered as powder. Often, however, the fuel is pelletised before transported, milled, and combusted. Fuel powder is transported as pellets because pellets have higher density than powder. The low density of powder makes it uneconomical to transport and difficult to store. Some of these powder burning plants use fuel delivered as briquettes. Medium-sized boilers use briquettes or pellets and residential heating uses pellets.

Sweden is not the only country where production and use of upgraded fuels are significant. The USA is a producer of wood pellets, approximately 2.9 TWh and the principal market for pellets is domestic residential heating (Rydehell & Löfgren, 2001). In Europe, there is a significant use of wood pellets in Denmark, Finland and Austria. (Olsson, 2001; Rydehell & Löfgren, 2001). Like the USA, the European countries mainly use upgraded fuels for residential heating. The briquetting technique is practiced worldwide. Production and use of briquettes can be found in North America, Europe, Asia, Africa, China, and Brazil (Eriksson &

Prior, 1990). In developing countries, densified biomass is produced mainly in the form of briquettes, which are used directly to substitute fuel wood or for carbonizing to produce briquetted charcoal. Pellets are rarely used (Bhattacharya, 2002). The production and use of biomass powder in large-scale combustion plants is unique to Sweden; however, in many countries coal powder is still a common used fuel.

## **Raw material**

Since the beginning of the 1990s in Sweden, the use of upgraded biofuels has increased substantially. So far, the production has been based on mainly residues from the forest industry such as sawdust, planer shavings and dry chips. One large producer also uses peat as raw material and one producer uses straw and grain residues as raw material (Olsson, 2002). Because upgraded fuel use has increased fast over the last five years, other raw materials such as peat, bark, logging residues, and energy crops are needed to further increase energy production from upgraded biofuels in Sweden.

### **Wood residues**

Wood residues describes several different fuel types that originate from trees. Wood residues may be delivered directly from forests or as by-products from different industries. Processing residues from sawmills, plywood or chipboard mills, and furniture factories mainly constitute the raw material used in the production of upgraded biofuels in Sweden. Sawdust, planer shavings, and dry chips (by-product from end crosscutting of dry lumber) from pine and spruce are the dominant raw material (Olsson, 2002; Lehtikangas, 2001). Shavings and dry wood chips have low moisture content (12%) while sawdust has moisture content up to 50%. Dry chips from mixed pine and spruce stemwood (without bark, moisture content of 12%) were the raw materials used in Paper **III** and **IV**.

Processing residues are also used by the board industry or as an internal fuel. Figure 2 show the use of by-products from Swedish saw mills in 2000 (Martinsson, 2003).

If the use of upgraded fuels largely increase, there is a need for new raw materials. Logging residues (treetops and branches), stemwood from early thinning, and bark (Johansson & Lundqvist, 1999; Lehtikangas, 2001) could all be used as biofuel sources.

The supply of logging residues depends on the demand for wood products and there are several analyses that have estimated this demand. Johansson & Lundqvist (1999) summarise theses analyses.

Stem-wood from early thinning can be used for pulp, woodwork, and energy. The amount available for energy production depends on the demand from these other industrial sectors (Johansson & Lundqvist, 1999).

As can be seen in Figure 2, bark is mainly used as an internal fuel at mills or sold as fuel to heating plants. According to Martinsson (2003), most of the bark from the wood processing industry is used today, and the future supplies will depend on internal use and the demand for energy in the pulp and paper industry.

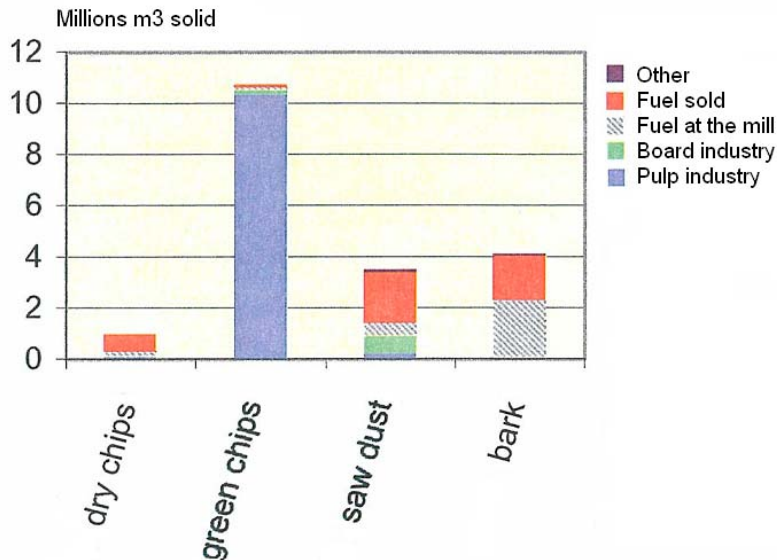

Figure 2. Use of by-products in Swedish saw mills in 2000 (Martinsson, 2003). Annual production  $\geq 5000$  m<sup>3</sup> solid.

These alternative raw wood materials differ from stemwood concerning physical characteristics and chemical composition, which influence the process and combustion properties (Lehtikangas, 2001; Öhman et al., 2002).

### Agricultural residues

In Sweden, agricultural biomass used for energy include willow (*Salix*) and reed canary-grass (*Phalaris arundinacea*), grown on land not used for food and fodder production, straw (a residue from cereal and oil seed production) (Johansson & Lundqvist, 1999), and cereal grains (Löfgren, 2001). Several Swedish studies estimate crop and straw use although the studies' estimates vary widely (Larsson, 2003) (Johansson & Lundqvist, 1999). Within these studies, the long-term potential for production of RCG and salix is estimated to 20-48 TWh (Larsson, 2003).

The use of solid biofuels from agricultural biomass was approximately 0.9 TWh in 2001 and the main part came from straw and salix (Swedish Energy Agency, 2002). Salix is mainly cultivated in southern Sweden and along the coast of the southern part of Gulf of Bothnia. In Northern Sweden, the use of salix is limited by the cold climate and short growing season (Ledin, 1996). In Sweden in 2001, the cultivation of salix amounted to approximately 15,000 ha. Salix is harvested every 3-5th year and the yield is approximately 10 tonnes DM/ha per year. Salix is

mainly used as wood chips in district heating plants and combined heat and power plants ([www.akerbransle.com](http://www.akerbransle.com)).

Compared to Denmark, the use of straw is very limited in Sweden. Today there are only a few combustion plants that use straw bales for fuel. One Swedish production company (Skånska Lantmännen) produces and uses pellets for district heating from straw and grain residues (Olsson, 2002). Overall, straw is used for energy in many countries. Denmark plans to build the largest pellet mill in Europe with a yearly production of 180 000 tonnes wood pellets and 130 000 tonnes straw pellets per year (Haaker, 2002). Recently in Sweden, grain crops have been explored as suitable for the production of solid biofuels. There are several advantages: they do not require processing; they can be harvested with low moisture content (10-13 %); and they have a high heating value (4 kWh/kg) (Löfgren, 2001). The crops can be cultivated over the whole country and their establishment via sowing requires little initial investment. Finally, the farmers are familiar with these crops and have the necessary equipment. However, there is always an ethical concern when using food products for energy production.

Reed canary-grass (RCG) is a perennial rhizomatous grass, which is native in Sweden and many other European countries (Figure 3). RCG is suitable for cultivation in most agricultural regions and a suitable energy crop for cold climates (Hadders & Olsson, 1997; Landström, Lomakka & Andersson, 1996). RCG is sown in the spring, and the first harvest is made in the spring of the third year and thereafter on a yearly basis. The grass reaches a height of about 2-m in autumn, and cultivation and harvesting technique is similar to conventional harvesting.



*Figure 3.* Salix and reed-canary grass (in front) cultivations in northern Sweden.

RCG was previously studied as a fodder crop, but a new harvest method invented in the late 1970s made it interesting as an energy crop (Hadders & Olsson, 1997). If RCG is harvested early in the spring rather than at the end of the growing season, it is beneficial for the biological production as well as the quality for energy purpose (Landström, Lomakka & Andersson, 1996). Leaching and leaf losses during the winter lower the concentration of undesired elements like Cl and K as well as ash content. The delayed harvest system gives a dry (85% dry matter content) and storable material that can be directly briquetted (Paper I), pelletised and pulverized (Kastberg & Burvall, 1997; Kastberg & Nilsson, 2000) without any artificial drying. The yield varies depending on site conditions and management, and the average yield is estimated to approximately 7 tonnes DM/ha (Lewandowski et al., 2003).

The fibre properties of spring-harvested RCG also make it useful for the pulp and paper industry in northern Europe (Finell et al., 2002). To achieve best pulp and paper properties, RCG has to be processed by dry fractionation before pulping. The process produces two fractions, internode chips, and leaf meal. The chips fraction can be used for pulp production and the leaf meal fraction for energy production (Finell et al., 2002; Paper I).

There is a difference in chemical elemental characteristics between stems and leaves. The highest concentrations of most nutrients exist in the leaves, and the ash content is on average twice as high in the leaves (Landström, Lomakka & Andersson, 1996; Paper I). As for other grasses and straw, the chemical composition of RCG varies depending on soil type and fertilisation (Landström, Lomakka & Andersson, 1996; Burvall, 1997; Paper I). Studies show that RCG grown on heavy clay soils gives higher ash contents (9-11%), mainly due to higher Si content; Si is introduced in the plant by absorption of silic acid from the soil (Zevenhoven, 2001). For RCG grown on humus rich soils, the ash content are typically 3-4% (Burvall, 1997; Paper I; Paper II). Different levels of fertilization only slightly affect the chemical composition of spring-harvested RCG compared to autumn harvested RCG (Landström, Lomakka & Andersson, 1996).

In this study (Paper I and II), spring-harvested reed canary-grass in Sweden from three different locations grown on three different soil types were examined. The soils where the RCG was grown had low, medium, and high humus content. Samples were chosen to give large variation in ash content. In addition, one of these materials was separated into stem and leaf fraction.

The use of spring-harvested RCG for energy purpose is still very limited. Today, in Sweden only one medium sized combustion plant produces and uses RCG briquettes and pellets for fuel (<http://www.btk.slu.se/eng/avdelningar/btc/default.cfm>) In northern Sweden, several pellet mills are interested in using RCG. Additional research has been started on the technical aspects of pelletising in order to ensure a reliable large-scale production. RCG is also used for energy in Finland (Bioenergy International, 2003).

Among the perennial grasses tested in the US and Europe, switch grass, miscanthus, giant reed, and reed canary-grass have shown the best potential for production of biomass. These four grasses differ in their ecological/climate

demands, yield, biomass characteristics, and crop management requirements. To get an efficient production of bioenergy from perennial grasses, the most appropriate grass species must be chosen for the given ecological/climate conditions. In middle and southern Europe, miscanthus and switch grass are mainly produced while giant reed is more suitable for the Mediterranean region. In North America, switch grass is the dominating herbaceous energy crop. Lewandowski et al. (2003) describes the development and current status of these four perennial rhizomatous grasses as energy crops in the US and Europe.

Straw, bagasse, coffee husks, and rice husks are used for fuel in other parts of the world. The production of straw can be found in both developing and developed countries, whereas the production of bagasse, coffee husks, and rice husks is predominantly found in the developing countries (Werther et al., 2000).

## Processing

Several studies comprehensively describe densification technologies for briquetting and pelleting (Eriksson & prior, 1990; Grover & Mishra, 1996; Petterson, 1999; Vinterbäck, 2000). This study includes the processing of wood powder fuels (Paper III and IV). In Sweden, biomass is processed as briquettes, pellets, and powder in stationary plants where they have access to cheap raw material, for example, from a sawmill. Depending on raw material, it must pass through several steps to the final product. The process can be based on dry materials or moist materials. Today, most plants are based on moist material due to limited access to dry raw materials. Figure 4 shows a flow of the general steps for processing of upgraded fuels in Sweden.

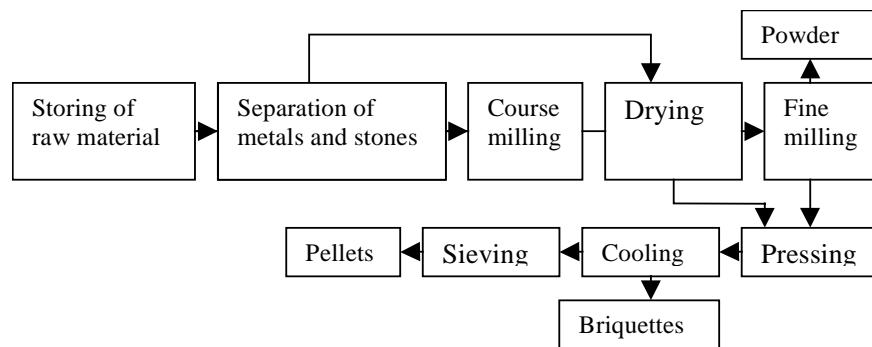

Figure 4. Flow chart for the production of briquettes, pellets, and powder from sawdust and shavings.

Because of the differences in moisture content and particle size, different pre-treatments are required before briquetting, pelletising, and pulverizing. The raw materials are separated from metals and stones and, if necessary, ground to a uniform particle size before drying. Depending on the final product (briquettes or

pellets), the material is also finely ground before pressing. For pellets and briquette production the raw material is dried to a moisture level of approximately 10% using flue gas dryers or superheated steam dryers. Rotary-drum dryers using combustion gases as heating medium is the most common technique used in Sweden (Ståhl, 2002). For powder production, the raw material is dried to a moisture level of approximately 6%.

## Briquettes

Briquetting of biomass can be done using direct compacting, piston press or screw press technology, without mixing it with some kind of binder, or using roll and char briquetting. To manufacture binderless briquettes from different raw materials, a piston press or screw press must be used. The raw material is compressed by a screw or a piston through a die to form compacts of cylindrical or other shapes. These machines come in many different forms such as mechanical piston presses, hydraulic piston presses, conical screw extruders, screw extruders without die heating, screw extruders with die heating and twin screw extruders (Eriksson & Prior, 1990; Pettersson, 1999; Grover & Mishra, 1996). In both cases, screw or piston presses, application of high-pressure increases the temperature of the biomass, and existing lignin in the biomass is assumed to act as a binder. Worldwide both technologies are being used for briquetting of sawdust and locally available agro-residues (Grover & Mishra, 1996; Bhattacharya, 1989; Li & Liu, 2000). In Sweden, the briquetting technology used is mainly mechanical and hydraulic piston presses (Pettersson, 1999) (Figure 5).

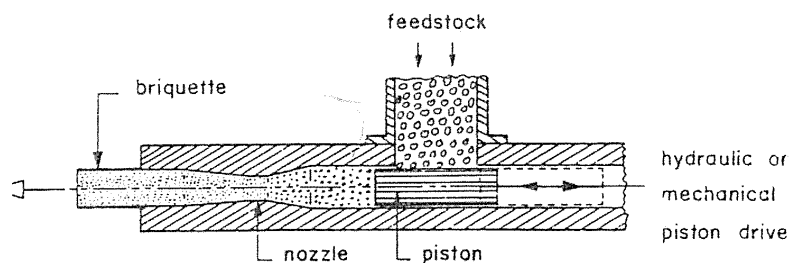

Figure 5. Illustration of a piston press (Bhattacharya, 1989).

Several factors affect the mechanical strength of the briquettes. These include the chemical and physical characteristics of the raw material as well as the variables of the densification process such as pressure and temperature. Moisture content of the raw material is an important parameter. The suitable range of moisture content for smooth briquetting appears to be 8 to 12% (Grover & Mishra, 1996; Bhattacharya, 1989; Li & Liu, 2000). If the moisture content is too low, the densification will be difficult due to improper heat transfer. If the moisture content is too high, steam will be produced, resulting in briquette disintegration (steam explosion) when the pressure from the nozzle is released. The particle size

distribution of the raw material also affects the densification process. In general, a finer chip size means a denser briquette and a better machine capacity. However, according to Grover & Mishra (1996) particles of sizes less than 1 mm are not suitable since they are less dense, more cohesive, and non-free flowing. Since the pressure applied will be transformed to heat during densification, the effect of pressure is linked to the effect of temperature. According to Carre et al. (1988), temperatures between 80 and 200°C, depending on the material, softens lignin, and after cooling, it ensures the binding between particles. Cooling is an important step since the steam formed during densification needs time to condense and the briquettes must keep their form. Excess heat is removed in a cooling line where the briquettes remain clamped and exposed to back-pressure as it cools. The length of the cooling line varies; it can reach 30 m in a straight line from the press.

In (Paper I) a mechanical piston press with a press cylinder, with a diameter of 75 mm was used to produce reed canary-grass briquettes. The raw material had different ash contents and additionally one of these materials was separated into a stem and leaf fraction. Before compressing, the material was cut in a hammer mill with a 3 mm sieve. The produced material contained high contents of fines, 20% less than screen size 0.25 mm and more than 90% of the material was <1 mm according to sieving. The moisture content varied between 9 and 13%. It was not possible to measure the pressure applied or the temperature. The briquette productions worked well for all raw materials, but analyses showed that the mechanical strength and bulk density of the briquettes were relatively low for several of raw materials used.

The RCG stem fraction showed the highest value for both bulk density and mechanical strength compared to the other raw materials. The procedure for these analyses is further discussed under “Physical characteristics–characterisation methods”, pp.36. Using the same analysis methods, Burvall and Örberg (1994) show that briquetting of not fractionated RCG produces similar durability of the briquettes produced as for the stem briquettes. However, in Paper I the content of fines < 3 mm was higher after the tumbling test compared to Burvall and Örberg’s study where the content of coarse material was higher, 15 to 45 mm, due to the raw material being more coarsely milled. Compared to wood briquettes, the durability of the RCG briquettes were overall lower (Burvall and Örberg, 1994). Several parameters might have affected the mechanical strength of the briquettes. Since it was not possible to measure the process parameters, it is difficult to draw any definite conclusions; however, the differences between stem material and the other raw materials described in Paper I might be due to a higher content of lignin and/or hemicellulose. At the time the experiments were performed, people had very little experience with briquetting RCG. Today, several extended time test runs have been done. RCG briquettes are used in a commercial power plant (<http://www.btk.slu.se/eng/avdelningar/btc/default.cfm>). Practical experiences from this plant show that optimisation of process parameters and raw material produce durable briquettes, comparable to commercial wood briquettes.



## Pellets

Pellets presses were originally developed for the production of animal feedstuffs and mineral-ore pellets. The main type of pellets press used for biomass in Sweden consists of a hard steel die that is perforated and two or three rollers. By rotating the die and/or the rollers, the raw material is forced through the perforations to form pellets. There are two main types of pellet presses: flat and ring types (Figure 6). The flat die type has a circular perforated disk on which rollers rotate while the ring die press features a rotating perforated ring on which rollers press on to the inner perimeter. The length and diameter of the holes in the die can be varied, which affects the temperature during pressing and the density and strength of the pellets. Most pellet producers do not add binders since studies show that some binders negatively affect the fuel characteristics (Olsson, 2001). Binders are also not needed for wood and RCG and many other raw materials if the process parameters and raw material properties are kept under strict control. To improve the capacity, water or steam can be added before pressing to adjust the raw material moisture and soften the lignin/hemicelluloses. This also improves particle binding. The pellets are warm (90-95°C) when leaving the dies where they are cut to suitable lengths. Horizontal or vertical cooling towers help to stabilise and harden the pellets. After cooling, residual fines are separated and returned to the process before the pellets are automatically bagged or stored into silos. As for briquettes, moisture content and raw material particle size influence pellet quality (Hopstadius & Sandström, 2002).

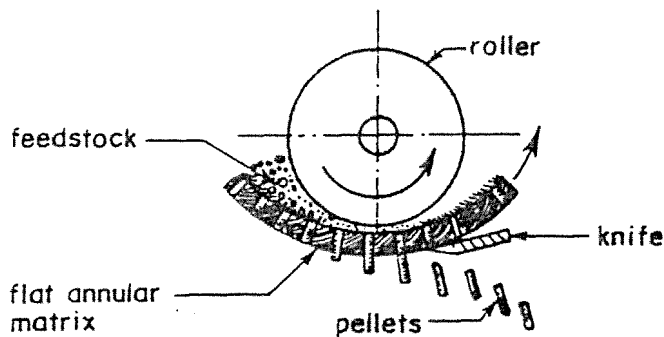

Figure 6. Illustration of a ring matrix pellets press (Bhattacharya, 1989).

## Fuel powder

In Sweden, the process for wood powder is similar as for pelletising with exception that the material is dried more thoroughly and fine milled instead of densified to pellets. After the drying step, the material is finely milled in special mills with smaller sieve sizes compared to the size used when milling for pellet production. Due to the risk for dust explosions, the powder is handled in closed

systems from milling to storing in silos. Wood powder can be produced with a variety of different physical properties such as particle size distribution and particle shape. Raw materials, the type of mill, and the type of sieve affect these properties (Scanlon & Lamb, 1995; Himmel et al., 1985; Paper III). Swedish producers mainly use impact mills. Impact mills use discs, hammers, swing beaters, beater plates, or impeller plates to crush the material. Knife mills can also be used.

In order to get a suitable amount of fines necessary for fast ignition and stable combustion, knife mills require a smaller sieve size compared to impact mills at least when using wood residues (Paper III). An explanation for this is that impact mills are designed to reduce particle size by impact energy transfer rather than by shearing, which usually results in large quantities of fines (Himmel et al., 1985). Other studies that examine milling of fuel powder in different types of mills are very limited. In most studies, the purpose has been to study the effect on particle size distribution on combustion properties. These studies used fine milled, coarsely milled, and blends from same type of mill (Reuther, Karsner & Jack, 1982; Adams, Raymond, Schmid, 1988). Since wood powder used in heating plants is delivered as pellets, the heating plants need a milling system to pulverise the pellets. Most of the Swedish plants use hammer mills (Malmgren, Tao & Wennström, 2000; Wiklund, et al., 1998).

Important factors during powder production are the capacity of the mills and energy consumption. In this thesis, the examination of physical properties of fuel powder is restricted to direct powder production using different mill types and sieve sizes. The wood powder fuels described in Paper III and IV were milled in two steps. The dry wood chips were first cut in a shredder with a 15 mm sieve. Then the material was cut in five different industry mills: three impact mills and two knife mills. A sieve size of 1.5 mm was used for three of the mills. For one knife mill it was not possible to produce a smaller sieve size than 2 mm, and for one hammer mill we chose to use a smaller sieve size (1 mm) to produce a fraction with more fines.

## Combustion Technology

Sweden has used biofuels for heating for a long time. Recently, Sweden has also increased its use of biofuels in combined heat and power plants. The combustion of upgraded fuels mainly started in medium-sized combustion plants (500 kW-2MW) in the 1980s and early 1990s. This encouraged the development of the combustion technology for pellets. A major step forward for the upgraded fuels was the introduction of pellets and powder instead of coal powder in boilers with a size up to 100 MW. In addition, this encouraged the development of wood powder burners. The most common combustion technologies used for upgraded biofuels in medium and large sized combustion plants are boilers, pre-furnaces, and burners. Briquettes are predominantly used in grate-fired boilers, pellets are used in pellets burners, and powder fuels are used in specially designed burners. For residential heating, pellets burners and pellets stoves are mainly used.

## Boilers

There are different technologies used for boilers. The most common systems are grate-fired boilers and stokers. The grate-firing systems are equipped with either flat or sloping grates. The grates are either moving or stationary, and they may be water or air-cooled. As the fuel bed moves, moisture evaporates before ignition, combustion, and cooling. Then the ash is transported out. The grates may consist of different sections where the primary and secondary air supply can be controlled independently. A staged combustion is obtained by separating the primary and the secondary combustion chamber. Secondary air injection should guarantee a complete mixture of flue gas and air. Grate firings are appropriate for biomass fuels with varying particle sizes and high ash content (Oberberger, 1998). These boilers are mainly used for fuel such as wood chips and bark, but they also work well for briquettes.

Another common technique is underfeed stokers where the fuel is underfed into the centre of the boiler. The ignited fuel is pushed forward and upwards by incoming fuel, and it is spread on a fixed horizontal grate. The combustion air is distributed under and over the fuel bed. Underfeed stokers are only suitable for biomass fuels with a low ash content (Oberberger, 1998). Ash-rich biomass fuels need more efficient ash removal systems.

Lately, several boilers specially designed for more dry and ash rich fuels have been developed in several European countries. They may have different designs depending on the ash content of the fuels and their slagging tendency. In (Paper I) a German Öko therm compact boiler was used for combustion of RCG briquettes (Figure 7). The boiler was developed in Germany for use of ash rich fuels such as miscanthus. This boiler has a capacity of 140-180 kW depending on fuel quality and moisture content. The boiler can handle fuel with moisture content between 5% and 30%. The boiler is equipped with an ash screw, a moving ash stoker, and a slag scraper to handle ash-rich fuels and slag. The frequency on the ash pusher can be regulated depending on the ash content in the fuel. The fuel is horizontally fed into the boiler by a stoker screw, and the ash bed is moved forward by the ash pusher. The combustion chamber is water-cooled, and the combustion air is distributed through the side walls. Above the combustion chamber, there is a ceramic valve to lengthen the time for the gases to complete their combustion, resulting in low levels of unburned pollutants and particles (Paper I). At the beginning of the experiments, the ash pusher affected the CO value; however, when the ash bed was high enough, the CO value stabilised. This ash pusher is now rebuilt. Instead of working back and forth in one move, the pusher slowly moves forward and the CO peaks are decreased. The oven temperature was measured above the ash bed using seven thermocouples, starting from the fuel inlet to the end of the oven (Figure 7). The results showed that the temperature measure points 1 and 2 was slightly higher (100°C) for RCG with high ash content compared to RCG with low ash content due to a higher ash bed. To obtain more information on variation in oven temperature and more comparable results between the fuel samples with high and low ash content, it would also be

interesting to measure the temperature inside the ash bed, especially since fuel with low ash content showed higher tendency to melt. This is further discussed on pp. 30.

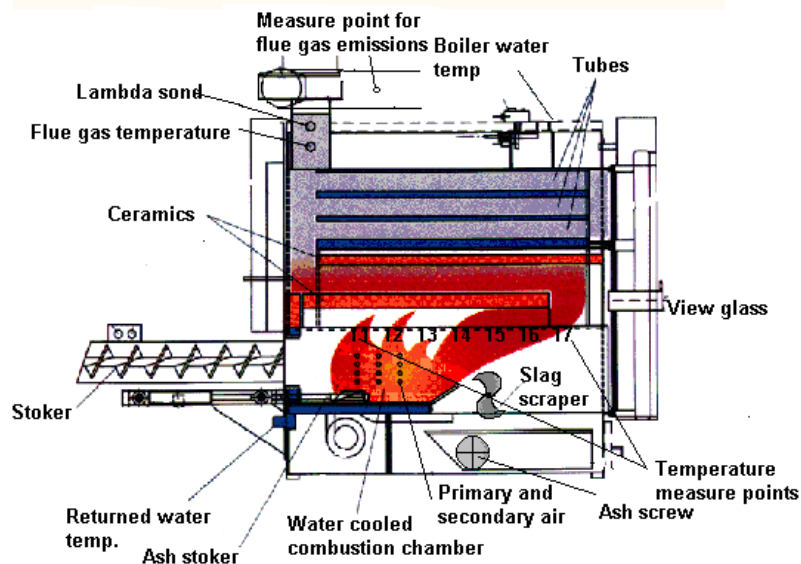

Figure 7. Illustration of Öko Therm Compact boiler, 150 kW for dry fuels.

### Pre-Furnaces

For not upgraded fuels with higher moisture content (>30%) such as bark or sawdust a pre-furnace connected to a boiler is often used. The principle for this technique is that ignition and combustion takes place in a special furnace outside the boiler while the combustion gases are complete combusted in the boiler. This technique can also be used for dry fuels such as briquettes and pellets if they are designed to withstand the higher temperatures produced by dry fuels.

### Pellets-burners

Special pellets burners have been developed for small and medium sized boilers. Although they may have different designs, these boilers usually use an insert where the combustion takes place and combustion air is distributed. The advantage of this technique is that existing boilers can be used. Depending on the way pellets are fed into the furnace, three basic principles of pellet combustion systems can be distinguished: underfed burners (Figure 8), horizontally fed burners, and overfed burners (Olsson, 2001; Löfgren, 2002). This technique is used mainly for wood pellets with low ash content.

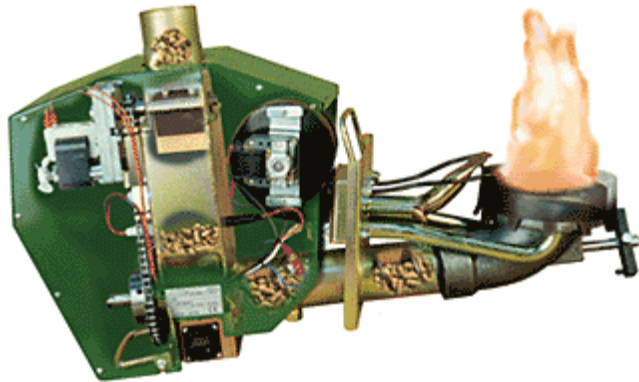

Figure 8. Illustration of an Ecotech pellets burner, 14-300 kW.

### Powder burners

Powder burners mix fuel and air to produce stable free burning flames and low emissions. Because conventional powder burners mix the fuel and air very rapidly, short hot flames and high burnout are often the result. However, in order to reduce the  $\text{NO}_x$  emissions, air staging techniques have been developed. Air staging delays the mixing of fuel and air to create a fuel rich zone close to the burner, which decreases the conversion of volatile nitrogen to  $\text{NO}$ . The combustion air then enters downstream in the flame to complete combustion. This is called burner air staging or internal air staging (Figure 9). Another approach is furnace air staging or external air staging where the tertiary air is added just above the burner (Figure 10).

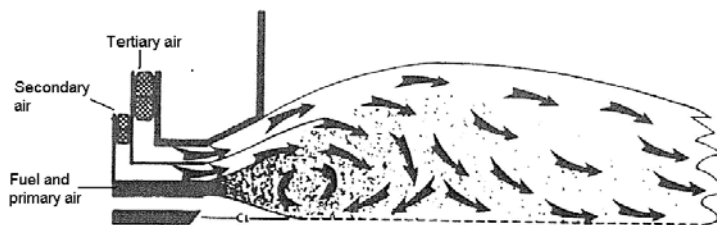

Figure 9. Illustration of burner air staging.

Aerodynamics and stoichiometry can make it difficult to achieve stable ignition and good burnout. By using a swirl principle on the burners, a flame with a strong rotation is achieved. The rotation contributes to the flame stability by recirculating hot combustion gases from down stream to the burner inlet. This allows the heat to dry and ignites the incoming fuel particles. Swirl vanes establish the swirl; by adjusting the vane angle, the degree of swirl can be controlled (Figure 11).

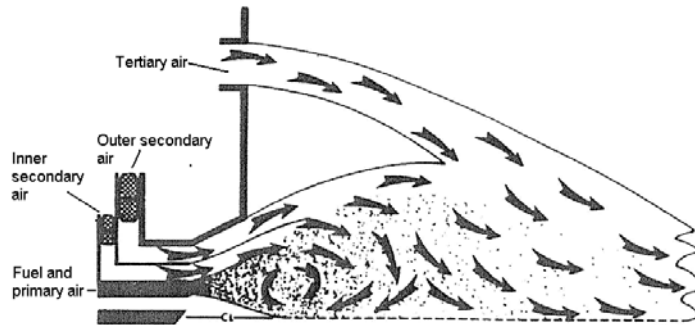

Figure 10. Illustration of furnace air staging.

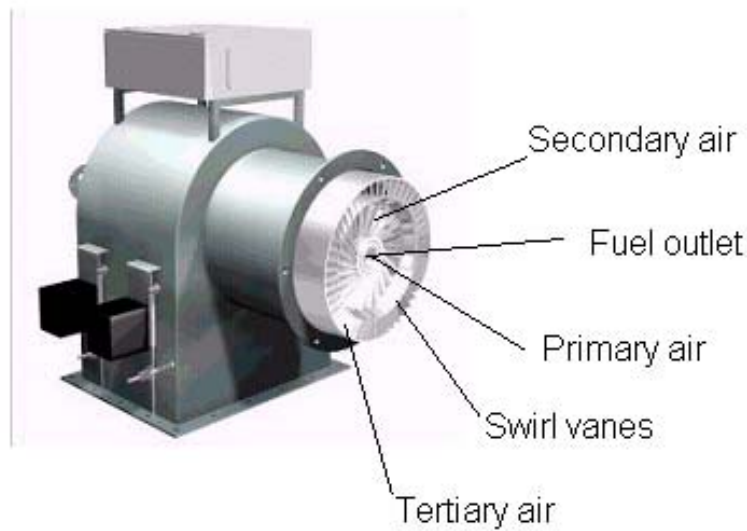

Figure 11. Shows air distribution and swirl vanes in a VTS Powder burner.

In Sweden, converting oil-fired or coal-fired boilers for combustion of wood powder has been a commercial technology for more than 10 years. Finely milled wood powder or finely milled pellets are combusted in special designed powder burners retrofitted in existing boilers. In Sweden, there are mainly two types of wood powder burners: the VTS burner and a burner from Petrokraft. The burners are low  $\text{NO}_x$  burners with internal air staging. The main differences between these burners relates to how the powder is fed to the flame. In the VTS burner, fuel mixed with transport air is transported through the centre of the burner and primary, secondary, and tertiary air is inserted through different inlets (Figure 11). In the burner from Petrokraft, there is an oil lance in the centre, surrounded by the air distribution and the fuel is inserted outside. The powder burner technique is

only used in large-scale heating plants (>1 MW). Using a small combustion unit, the demand on the powder quality and feeding equipment is increased. To produce a stable flame, the feeding must be optimised and even, the fuel needs to be finely milled, and fuel should be of high quality with no lumps or splinters (Paper IV). The effect of burner air staging might be less when using a small burner since the distances between primary, secondary, and tertiary air inlets are too short to have a significant influence on the residence time. (Paper IV).

The combustion tests presented in Paper IV were carried out using a VTS powder burner with a capacity of approximately 150 kW. This powder burner is, as in the large VTS burners, a swirl burner where the combustion air is divided into four flows: powder transport air, primary air (high pressure), secondary air, and tertiary air (Figure 12). The burner is a free flame burning type and a ceramic cone was placed at the front of the burner. The burner was connected to a 150 kW boiler.

The combustion tests in Paper IV studied the effects of particle characteristics on emissions from burning wood powder. These results are further discussed under “Physical characteristics-effects of fuel characteristics on emissions during combustion” pp. 44. During the combustion experiments, burner air-staging was also used. Compared to fuel characteristics, burner air-staging had little influence on the combustion result.

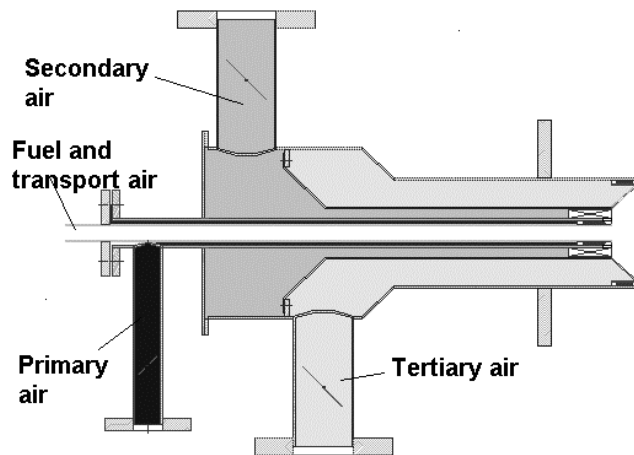

Figure 12. Illustration of VTS powder burner, 150 kW used for wood powder combustion.

The reduction of excess air in low  $\text{NO}_x$  applications is also important, but it is limited due to the risk of high CO emissions and low burnout. Flue gas recirculation and re-burning may also be used (Eklund, 2002)

Recently, the Swedish company TPS has developed a cyclone-type burner (Bioswirl) for powder fuels and crushed pellets. The powder is pyrolysed within a cyclone chamber of the burner forming pyrolysis gas, which is subsequently introduced into the furnace section of the boiler through an opening (throat) where

secondary and tertiary air is introduced. In the furnace, a controlled gas flame is established. The main advantage of this technique is a low sensitivity to particle size distribution (Lundberg, 2002). The effect of the burner will be available in the range of 0.5-25 MW.

## **Fuel quality**

Fuel quality defines the fuels chemical and physical characteristics. Chemical characteristics include moisture content, ash content, concentrations of inorganic elements, and ash forming elements. The chemical characteristics depend on raw material, growing conditions, and agricultural management. Physical characteristics describe parameters affected by the type of processing the biomass has undergone, such as particle size, particle shape, bulk density, unit density, and mechanical strength (pellets and briquettes). In order to design a combustion plant, or choose the proper biofuel for an existing plant, it is important to know the amounts of inorganic elements in different biofuels, their physical characteristics, and the effects they cause during combustion.

### **Chemical characteristics**

The composition of biofuels is complex and the main components of interest include six major elements (C, H, O, N, S, Cl) and at least 8 other elements (Si, Al, Ca, K, Mg, Na, P, Fe) in the inorganic phase important to ash characterisation. The main constituent of biomass is C, making up from 30 to 60% of the weight of dry matter depending on ash content. Typically, 30 to 40% weight of the dry matter in biofuels is O. H is the third major constituent, comprising typically 5 to 6% of the dry matter. N, S, and Cl are usually less than 1% dry matter, but it may exceed this. In Sweden, raw biomass materials that are used and examined for upgraded biofuels, for example, wood residues, straw, peat, and spring-harvested reed-canary grass contain similar concentrations of C, H, and O but show significant differences in the concentrations of N, S, and Cl and the main ash forming elements. In Table 1, the fuel characteristics for reed canary-grass depending on harvest time (Burvall, 1997), soil type (Paper I), stem wood (Paper III, IV), peat (Samuelsson, Burvall, & Igsell), and straw (Sander, 1997) are shown.

The dominating ash forming components in these fuels are alkali metals, alkaline earth metals, and Si. However, stem-wood is an ash poor biofuel, and the ash-forming constituents contain greater amounts of Ca and less Si. The bark, leaf, and branch fractions of wood have higher ash contents as well as higher levels of K, N, and S (Nordin, 1993; Lehtikangas, 2000).

Compared to wood, RCG and straw are ash-rich fuels and contain higher levels of Si and K, and they contain higher content of Cl, N, and S. Compared to wood, peat also has a higher content of ash, N and S. The chemical composition of RCG varies depending on soil type and harvest method. The spring harvest system for



RCG results in reduced concentrations of undesirable elements such as K and Cl, and the ash content is slightly lowered. Different soil types affect the uptake of ash components, especially for Si. Depending on soil type, the ash content can vary from 2 to 10% (Burvall, 1997; Paper I and II). In RCG with low ash content, the ratio Si:K is often lower, which negatively affects the ash melting behaviour (Paper I and II).

Table 1. *Example of fuel characteristics for different biomass fuels.*

% DM	RCG <sup>a</sup> Spring	RCG <sup>b</sup> Spring	RCG <sup>c</sup> Spring	RCG <sup>d</sup> Autumn	Stem <sup>e</sup> wood	Straw <sup>f</sup>	Peat <sup>g</sup>
Ash	7.4	3.1	9.1	6.4	0.4	4.5	4
Volatile	77	81	76	71	84	78	70
C	45	46	44	46	50	47	56
H	5.4	5.9	5.3	5.7	6.1	5.9	5.8
O	41.5	43.9	40.7	n.a.	43.9	n.a.	n.a.
N	0.3	0.6	0.4	1.3	0.06	0.7	2.1
S	0.07	0.08	0.07	0.17	<0.01	0.15	0.29
Cl	0.04	0.04	0.03	0.56	<0.01	0.4	0.03
Si	3.0	0.91	3.8	1.2	0.008	0.8	0.33
Al	0.02	0.03	0.01	n.a.	0.002	0.005	0.09
Ca	0.13	0.20	0.13	0.35	0.07	0.4	1.02
K	0.20	0.18	0.15	1.23	0.03	1.0	0.012
Mg	0.05	0.06	0.05	0.13	0.01	0.07	0.004
Na	0.01	0.01	0.01	0.02	0.001	0.05	0.008
P	0.09	0.08	0.07	0.17	0.005	0.08	0.045

<sup>a-c</sup> RCG from different soil types used in Paper I and II.

<sup>d</sup> Average value (Burvall, 1997)

<sup>e</sup> Commercial wood powder used in Paper IV.

<sup>f</sup> Average value.

<sup>g</sup> Average value for peat

n.a. not analysed

### *Methods for chemical analyses of fuels and ash*

Biomass fuels and ashes can be analysed with different elemental analysis methods. Some of these methods were developed for other solid fuels, mostly coal, but they have been found adequate and adopted as standards for biomass samples as well. Other methods are less successful in their application to biomass samples such as methods for evaluating ash fusibility (see discussion below). The analyses used for biofuels include the proximate analysis, the ultimate analysis, and the analysis for major elements in ash. The proximate analysis includes moisture content, ash content, volatile matter, and fixed carbon. The ultimate analysis determines the content of the elements: C, H, O, and S. These analyses provide the major elemental composition of the fuel on a dry basis. The major elements in ash include Si, K, Ca, Mg, Mn, Na, P, Al, Fe, and Ti. Trace elements may also be included. The procedure, precision, and standard used for the analyses used in this thesis are summarised in Table 2.

Table 2. *Methods used for fuel and ash analyses of biofuels in this thesis.*

Parameter	Methods and precision RSD	Standard
Net calorific Heat value	By bomb calorific method and calculation of net calorific value (Leco AC 300), ( $\pm 1$ %)	SS ISO 1928:1
Moisture content	Sample dried in air at $105 \pm 2^\circ\text{C}$ ( $\pm 5$ %)	SS18 71 70:2
Ash content	Heated to $550^\circ\text{C} \pm 25^\circ\text{C}$ in air, ( $\pm 5$ %)	SS18 71 71:1
Volatile matter	Heated at $900^\circ\text{C}$ out of contact with air for 7 min. ( $\pm 2$ %).	SS ISO 562
C, H, N	High-temperature combustion in oxygen ( $1050^\circ\text{C}$ ), with an IR detection procedure (LECO CHN 1000) (LECO N 2000), ( $\pm 5$ %, 5%, 20%).	
O	Oxygen is determined as the difference between 100 and the sum of C, H, N, and S.	
S	High-temperature tube furnace combustion in oxygen ( $1350^\circ\text{C}$ ) with an IR detection procedure, (LECO SC 432), ( $\pm 10$ %).	SS1871 77:1
Cl	Using Eschka mixture, titration by Mohr procedure, ( $\pm 20$ %).	SS187154.1
Si, K, Ca, Mg, Mn, Na, P	Melt with $\text{LiBO}_2$ ; wet dissolving with $\text{HNO}_3$ , final determination using ICP-AES, ( $\pm 1$ , 2, 2, 3, 4, 4, 3 %).	
Content unburned Matter	Heated to $550^\circ\text{C} \pm 25^\circ\text{C}$ (oxidising atmosphere), ( $\pm 10$ %).	SS187187:1

Table 3. *Nitrogen content in wood powder, analyses by two different laboratories.*

Sample	Lab 1. Nitrogen content %	Lab 2. Nitrogen content %.
1. Wood powder (stem wood)	0.10, 0.09	0.056, 0.057, 0.056
2. Wood powder (stem wood)	0.15, 0.17	0.047, 0.048, 0.050
3. Wood powder (stem wood)	0.088, 0.067	0.055, 0.055
4. Wood powder (stem wood and a few percentage bark)	0.20, 0.16, 0.13	0.096, 0.097, 0.097

The N content is given with a higher precision than the method allows.

The accepted precision between duplicate samples varies from 1 to 20% depending on what parameter that is measured. The nitrogen content is a critical analysis concerning wood powder combustion. Wood powder from stem-wood contains low levels of nitrogen and a small increase in nitrogen content may significantly increase the NO emissions during combustion (Paper **IV**). Low content of fuel nitrogen ( $<0.1\%$ ) is difficult to analyse with high precision. The accepted precision between duplicate samples is usually  $\pm 20$ - $25\%$ , depending on the laboratory. There is also a difference between different laboratories. In Table 3, results from analyses of nitrogen content in the wood powder fuels used in Paper **III** from two different laboratories can be seen. The results from these analyses show a large difference between the two laboratories, and laboratory 1 showed low precision. In this study, the results from laboratory 2 was used (Paper **IV**).

### *Effects on emissions*

The concentrations of N, S, and Cl in different biofuels are important because they may cause emissions  $\text{NO}_x$ ,  $\text{SO}_2$ , HCl and also, for Cl, increased emissions of chlorinated aromatic compounds such as dioxins. Although the formation of these emissions depend on other parameters such as combustion equipment and operation conditions, higher concentrations are most important for increases of the emissions (Werther et al. 2000). S and Cl also influence ash melting and fouling behaviour and can cause corrosion in the boiler (Oberberger, et al., 1996; Miles, et al., 1996; Baxter, et al., 1998; Jenkins, et al., 1998). Other pollutants formed are products of incomplete combustion such as particles, CO, hydrocarbons including volatile organic compounds (VOC), and polycyclic aromatic hydrocarbons (PAH). These pollutants are mainly influenced by the combustion equipment, process, and physical fuel properties (Jenkins, et al. 1998; Werther, 2000; Paper I and IV). The amount of ash and the composition of ash may also influence these pollutants. This thesis examines the effects of fuel quality and to some extent operation conditions of the major toxic pollutants (CO,  $\text{NO}_x$ ) (Paper IV, Paper I).

Emissions of  $\text{NO}_x$  arise predominantly from nitrogen in the fuel since most commercial biomass users operate at temperatures low enough that thermal formation contributes only to a small fraction of the total  $\text{NO}_x$  (Olanders & Gunners, 1994; Jenkins et al., 1998; Winter, Wartha & Hofbauer, 1999; Salzman & Nussbaumer, 2001). A higher content of N in the fuel is likely to increase the  $\text{NO}_x$  emissions. However, the conversion of fuel N to  $\text{NO}_x$  has been shown to decrease with increasing fuel N concentration by up to 1% N. The conversion of fuel N to  $\text{NO}_x$  also depends on the operation conditions and combustion equipment (Olanders & Gunners, 1994; Van der Lans, Glarborg & Dam-Johansen, 1997; Jenkins, 1998; Winter, Wartha & Hofbauer, 1999; Salzman & Nussbaumer, 2001).

In Paper I, five fuels were used in combustion experiments, consisting of 3 RCG samples with different ash contents (3-10%), and one of these materials was separated into a stem and leaf fraction. The result from the experiments showed that the variation in ash content did not affect the CO values. The flue gas analyses resulted in low CO values (<42 mg/MJ, except one experiment) and low values for particles in the flue gas (<150 mg/Nm<sup>3</sup>) (no purification of flue gas).

Figure 13 and 14 show the effect of fuel nitrogen content on NO emissions for RCG fuels and wood fuels (Paper I and IV). The fuels with high N content (RCG briquettes) showed generally low conversions whereas fuel with low N content (wood powder) showed high conversions (Figure 13). In addition, there is a difference between combustion techniques: grate combustion compared to powder combustion. The conversion is higher for powder combustion. Figure 14 illustrates that NO emissions increase with increasing fuel-N content.

The formation mechanism behind  $\text{NO}_x$  formation is very complex and numerous studies have been performed on coal and biomass concerning different aspects of  $\text{NO}_x$  formation, reduction, and control in combustion processes (Radojevic, 1998; Winter, Wartha & Hofbauer, 1999; Muzio, Quartucy & Cichanowicz, 2002;

Glarborg, Jensen & Johansson, 2003). This thesis does not examine the formation mechanism for different emissions.

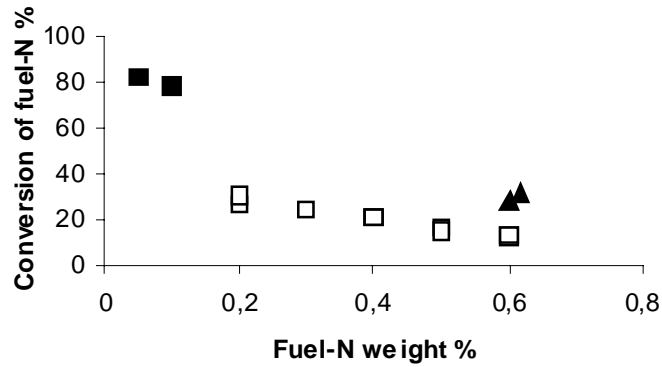

Figure 13. The conversion of percent fuel nitrogen to NO vs. Fuel N content. Fuel N 0.05-0.6%. ■ Wood powder combusted in a powder burner (Paper IV). □ RCG briquettes combusted in a compact boiler (Paper I). ▲ RCG powder combusted in a powder burner (Kastberg & Nilsson, 2000; Kastberg & Burvall, 1997).

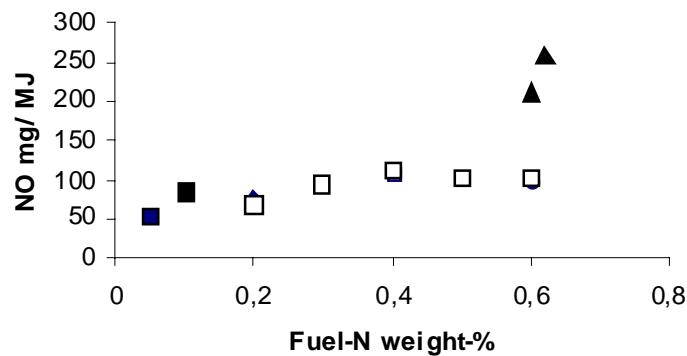

Figure 14. The concentration of NO mg/MJ vs. fuel-nitrogen content. Fuel N 0.05-0.6%. ■ Wood powder combusted in a powder burner (Paper IV). □ RCG briquettes combusted in a Öko Therm compact boiler (Paper I). ▲ RCG powder combusted in a powder burner (Kastberg & Nilsson, 2000), (Kastberg & Burvall, 1997).

#### Effects on ash melting

The ash forming elements and amount of ash are important for deposit formation and the design of the combustion plant. The main mechanism for ash deposits in biomass combustors are now reasonably well understood (Baxter et al. 1998;

(Miles et al. 1996; Obernberger et al. 1997; Jenkins et al. 1998;). Deposit formation can be divided into slagging and fouling. Slagging is referred to as deposits in a molten or highly viscous state and found in the flame section of the furnace (subjected to radiant heat). Foulings are deposits built up largely by species that have vaporised and then condensed, and it occurs in the cooler furnace region where the heat exchanger equipment is located. Baxter et al (1998) define four undesirable effects of deposits: (1) deposits retard heat transfer and decrease the capacity and efficiency of the boiler; (2) deposits can grow to the extent that flow through the boiler is restricted and causes mechanical damage; (3) deposits accumulate in hoppers and on grates in forms unmanageable by the ashing facility, leading to shutdown; (4) deposits are associated with corrosion.

In the literature, terms such as agglomeration, sintering, and melting are used in different ways. The term agglomeration is defined as the phenomenon where particles gather into clusters of larger size than the original particles (Zevenhoven-Onderwater, 2003). Agglomeration takes place in fluidised bed combustors where combustion takes place inside a hot bed of sand. Sintering is defined as the phenomenon where loosely attached particles become more dense, forming a compact hard mass; it may proceed in at least three different ways (Skrifvars, Backman & Hupa 1998): (1) through a presence of a molten phase (partial melting); (2) through chemical reactions; (3) through solid-state sintering processes. For fluidised beds both terms sintering and agglomeration are used since the particles can be held together by a molten phase. In Paper II, we focus on sintering through the presence of a molten phase.

A melt that is formed in ash from biomass fuels can belong to either salts of alkali (mixtures of Na and K sulphates, chlorides and carbonates) and salts of alkaline earth metals (mixtures of Ca and Mg sulphates, chlorides and carbonates) or oxide/silicates systems. A common oxide/silicate system for biomass ashes is the  $K_2O$ - $CaO$ - $SiO_2$  system (Paper I, II). Sintering through the presence of a molten phase is a function of chemical composition and temperature. If thermodynamic or experimental data are available and the composition is known, the amount of liquid present at a given temperature may be predicted from phase equilibrium diagrams (Hansen, et al., 1998; Öhman, et al., 2000; Paper II) or chemical equilibrium calculations (Backman & Nordin, 1998; Skrifvars, Backman & Hupa, 1998; Zevenhoven-Onderwater, 2001).

Potassium is a major element of concern for ash melting behaviour of biomass fuels. Si in combination with K can lead to the formation of low melting silicates, and K can react with S and form sulphates on combustor heat transfer surfaces. Cl is a major factor in deposit formation. Cl appears to facilitate the transport of alkali from the fuel to surfaces where the alkali often forms sulphates. Si is often a major element in ash rich fuels; by itself, silica does not present any problem for biomass boilers. The melting point is high,  $> 1650^\circ C$ . However, the melting point of silica-containing material decreases from about  $1700^\circ C$  to less than  $750^\circ C$  when K is introduced to form K silicates (Baxter et al., 1998; Paper II). Ash with a high silica content also appears to be more voluminous, which demands special ash handling equipment (Paper I).

For spring-harvested RCG, the demand on the combustion equipment is higher compared to upgraded wood fuels. The ash content is higher and it contains high levels of silicon. The bulk density on bottom ash can be 2 times lower for RCG ash compared to wood ash (Burvall, 1993). Studies and practical experiences show that, with proper combustion equipment and optimisation, RCG briquettes and pellets can be combusted with good results despite differences in chemical composition (Paper I). However, compared to wood fuels, the tear and wear of the equipment will likely be higher, and the running expenses will be higher for plants using densified RCG compared to wood (stem) briquettes and pellets. The results in Paper I and II show that there is a large variation in ash content in RCG and that the ratio Si:(Ca+ K) is most important for the ash melting behaviour. RCG with low ash content, < 5%, seem to have a faster melting process due to higher content of K in relation to Si, resulting in more melting in the lower temperature range (< 1200°C).

Experiences with combustion of RCG powder are still limited. A full-scale combustion trial in a commercial power plant for wood powder (30 MW) and a combustion test in a small-scale burner (150 kW) have been done (Kastberg and Burvall, 1997; Kastberg & Nilsson, 2000). The results from these trials show that the ash behaviour needs to be studied further. In the large-scale burner, deposits in the combustion chamber and on convection surfaces were found. There were also problems transporting the ashes out of the electric filters caused by the large volumes of ashes; however, these filters were not designed to handle large volumes of ash. In the small combustion burner, the ash from this specific fuel sample was slagging. In addition, porous deposits were found on the walls of the boiler.

#### *Prediction of ash melting behaviour*

Estimation of melting behaviour of ashes includes a variety of methods. Today, there are several theoretical, empirical, and laboratory methods for prediction of ash melting behaviour available. Öhman (1999) described several of these methods. Commonly used are conventional ash fusion standard tests (Paper II). Additional tests that recently have been applied to different types of biomass include the compression strength tests (Skrifvars, Backman, & Hupa, 1998;), (Skrifvars et al. 1999), chemical equilibrium model calculations (Backman & Nordin, 1998; Skrifvars, Backman & Hupa, 1998; Zevenhoven-Onderwater, et al. 2001), high-temperature light microscopy (Hjuler, 2000), and bench-scale fluidised-bed combustion tests (Öhman, 1999; Öhman, et al., 2002; Paper II). A common theoretical method used is the use of phase diagrams to determine liquid temperatures that parallel the fusion temperatures of the formed ash (Hansen, et al., 1998; Öhman, et al., 2000; Paper II).

In Paper II, a comparison between three different techniques to predict ash melting was performed. We studied combustion ashes from RCG with various chemical compositions using two laboratory methods: ASTM fusion tests and a bench-scale fluidised-bed combustion tests. To predict ash fusion temperatures from elemental composition, we used melting temperatures obtained from the phase diagram SiO<sub>2</sub>-K<sub>2</sub>O-CaO.

### Standard ash fusion test

The standard ash fusion tests are the most commonly used laboratory method and the only standardised approach to predict ash-melting behaviour. There are many variants of the ash fusion tests and these are described in detail in their respective standards: AFT, ISO, BS, GOST, SABS, ASTM, DIN, AS. These tests are based on the external shape, deformation, shrinkage, and flow of a pyramidal or cylindrical pellet of ash during heating in a laboratory furnace in an oxidising (air) or a reducing atmosphere (CO/CO<sub>2</sub>). There are four identified temperatures for the ASTM test (Figure 15) (1) the initial deformation temperature at which the first rounding of the tip of the ash cone is observed; (2) the softening temperature at which the cone has fused to a spherical lump in which the height of the ash cone has been reduced to its width at the base; (3) the hemispherical temperature at which the height of the cone reduces to half of its width; (4) the fluid temperature at which the fused mass has spread out in a thin layer with a maximum thickness of 1.6 mm. The furnace operates at 260-1650°C in an oxidising atmosphere, and the temperature increase in the furnace is 8°C/min.

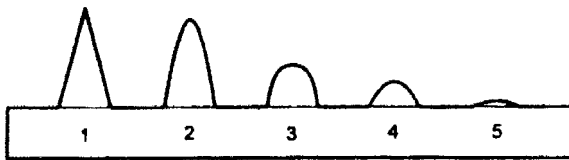

Figure 15. Illustration of the ASTM ash fusion test. 1. Cone before heating; 2. IDT Initial Deformation Temperature; 3. ST Softening Temperature ( $H = W$ ); 4. HT Hemispherical Temperature ( $H = 1/2W$ ); 5. FT Fluid Temperature ( $H = 1.6 \text{ mm}$ ).

One criticism of these tests are that the ash samples are not the same as the ash produced during combustion. The ashing temperature in the laboratory is much lower compared to the situation in the combustion furnace. According to Swedish standard (SS 187171), the ashing temperature should be maximum 550 °C. However, when ash fusion tests were done on the combustion ashes collected during combustion experiments with RCG briquettes, the result did not show any significant differences between the laboratory ash and the combustion ash (Paper II). Another criticism is that the melting starts at a far lower temperature than what the analysis shows, and reproducibility and repeatability have shown to be poor (Huffman, Huggins & Dunmyre, 1981; Coin, Kahraman & Peifenstein, 1996; Hansen, et al., 1997). Of particular concern is the identification of the initial deformation temperature. The repeatability limits for initial deformation temperatures for ASTM is 30°C and the reproducibility limit in oxidising atmosphere is 55°C. The deformation temperature is the temperature that has been accepted as the temperature where the ash first softens and may become sticky, and it is the most critical temperature to identify since it is based on the operator's judgement. One problem is that the appearance of the first melt is not detected because it takes place inside the pyramidal or cone, and it does not necessarily affect the shape of the body. The cone may also change form or position without

the tip of the cone being rounded. Several studies show that the initial cone deformation does not occur with first liquid formation but requires more extensive melting (Huffman, Huggins & Dunmyre, 1981; Coin, Kahraman & Peifenstein, 1996; Hansen, et al., 1997). This seems to be more frequent for biomass fuels with high silica content (Paper II, Natarajan, et al., 1998). High silica content gives a rigid ash structure that does not easily permit the deformation of the cone in the ASTM ash fusion test. In study II, it was not possible to do the tests in a reducing atmosphere. However, RCG have been analysed in reducing conditions and the results from these studies show that initial deformation temperature is slightly lowered under reducing conditions (Hansson, 2003). The same result was obtained for bagasse and olive flesh in a study by (Natarajan et al., 1998) where the initial melting temperature was 40°C and 180°C lower respectively in a reducing atmosphere.

#### The fluidised bed agglomeration method

The fluidised bed agglomeration method predicts bed agglomeration tendencies in fluidised beds (Öhman, 1999), but it has also shown to be a useful sintering test for collected ash (Paper II, Öhman, et al., 2002). The bench-scale reactor seen in Figure 16 has an effect of 5 kW. To obtain isothermal conditions in the bed, and to minimise the significant influence of cold walls in such a small-scale unit, the reactor is equipped with electrical wall heating elements to equalise the wall and bed temperatures. The experiments were performed in a sand bed consisting of 98% SiO<sub>2</sub>. The bed is loaded with an ash sample under normal fluidised bed combustion conditions. The excess oxygen concentration is controlled to 6%<sub>dry</sub> by mixing propane and air in a combustion chamber before the air distributor. The bed temperature is set to 760°C, and thereafter the bed temperature is increased at a rate of 3°C/min by external heaters in a homogenous and controlled way until agglomeration is achieved. The onset of agglomeration is determined by monitoring differential pressures and temperatures in the bed. The detection of initial bed particle cohesion is facilitated by Principal Component Analysis (PCA), considering all bed-related variables (temperatures and differential pressures) simultaneously. The agglomeration temperature is defined as the temperature where the first molten phase appears that are able to glue the bed particles into agglomerates. Defluidisation is defined as the total collapse of the fluidised bed resulting in a decreasing pressure drop or temperature change (Figure 17).

In Paper II, the agglomeration temperature was used. A sensitivity analysis showed that the agglomeration temperature of a specific fuel could be determined to 899°C with a repeatability of +/- 5°C (STD). The inaccuracy was determined to be +/-30°C (STD), considering the normal variation in all operating variables (Öhman & Nordin, 1998).

#### Ternary equilibrium phase diagram

A method to relate ash fusion temperature to chemical composition is to use a ternary equilibrium phase diagram. In theory, phase diagrams yield the lowest temperature at which the ash will be completely liquid (liquidus temperature), the highest temperature at which the ash will be completely solid (solidus temperature), and the composition and percentages of solid and liquid phases at



intermediate temperatures (Figure 18). This temperature range between the first melting temperature and the complete melting temperature may be several 100°C.

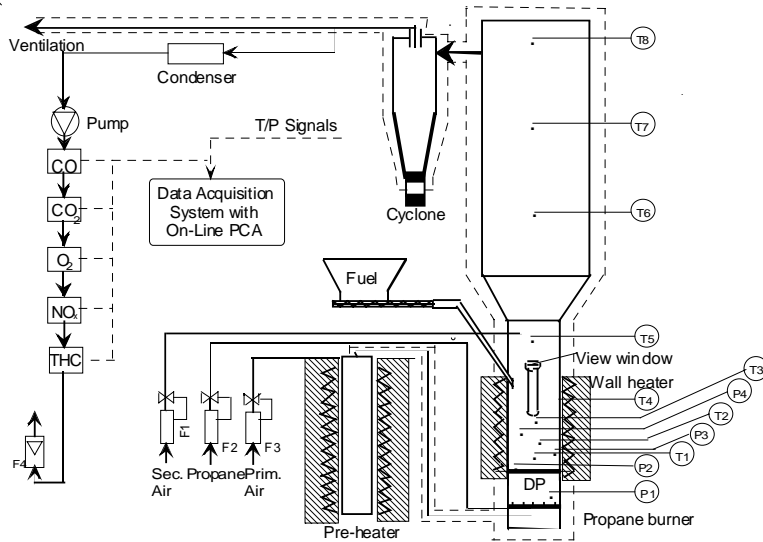

Figure 16. Experimental set-up: controlled fluidised bed agglomeration test facility. DP: distributor plate; F1, F2, F3: mass flow controllers; P1-P3, differential bed pressures; T1-T6, thermocouples (Öhman, 1999).

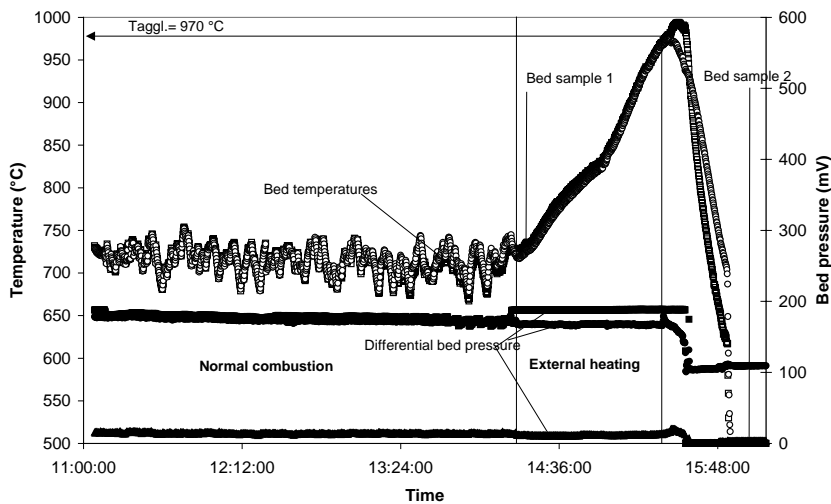

Figure 17. Typical illustration of bed variable fluctuations. The bed temperature is increased by 3°C/min until agglomeration is achieved (Taggl). The agglomeration temperature is initiated by a temperature change and then a pressure drop (Öhman, 1999).

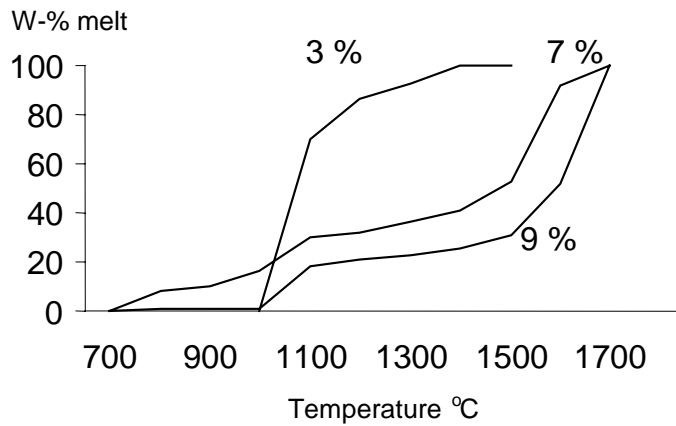

Figure 18. Melting behaviour of reed canary-grass samples with different ash contents extracted from the ternary diagram  $K_2O$ - $CaO$ - $SiO_2$ .

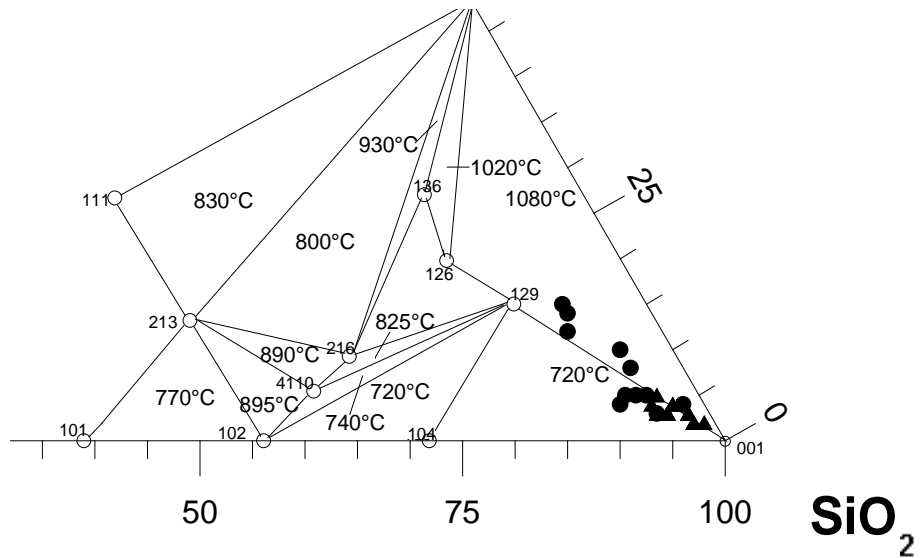

Figure 19. Part of the  $K_2O$ - $CaO$ - $SiO_2$  ternary diagram with some solidus temperatures (Morey, Kracek & Bowen, 1930) and the compositions of RCG samples from different growing sites in Sweden (Paper II). To the left  $CaO$  and in the top corner of the triangle  $K_2O$ . Scale on the side of triangle in % of each oxide respectively.

The basis of all work on phase diagrams is the phase rule (Gibbs, 1874), and it applies only to equilibrium states of a system, which require equilibrium within each phase and between co-existing phases. The use of phase diagrams is a theoretical method. Its accuracy declines with an increase in number and levels of other elements in the ash, and many biomass fuel ashes contain a variety of elements. However, the ash forming elements in many biomass fuels and specially

in RCG is dominated by Si, K, and Ca, oxides of which may constitute up to 90% by weight (Paper II). The system  $K_2O-CaO-SiO_2$  has been experimentally determined by (Morey, Kracek & Bowen, 1930). The lowest solidus temperature or first melting temperature is  $720^\circ C$  for compositions rich in silica and with more  $K_2O$  than  $CaO$ , meaning that these fuels will be found in the lower right triangle of the diagram (Figure 19). An increased  $CaO$ -content, the first melting temperature increases above  $1000^\circ C$  (Figure 19). Phase diagrams are useful as a first screening method for a better understanding of the general ash melting behaviour.

The results in Paper II showed that melting seems to start at far lower temperatures than what the ASTM ash fusion test detects. Comparing the bed agglomeration method and the ASTM ash fusion test, the difference were over  $600^\circ C$  for the RCG with high ash content, while the differences among the fuels with low ash content were about  $150-200^\circ C$ . Natarajan produced the same result where the largest difference ( $600^\circ C$ ) could be seen for fuels with high silica. One explanation for this is that a deformation of the ash cone using ASTM can probably not be seen until the silica started to melt to a higher extent. Thus, as could be expected from earlier studies, the ASTM ash fusion test is not suitable for predicting ash-melting behaviour of RCG. Even in a reducing atmosphere or by using the combustion ash the initial melting temperature differs too much compared to other methods.

A relatively good agreement was obtained between the bed agglomeration method and the use of a phase diagram. However, the agglomeration method is mainly a method to predict agglomeration behaviour in fluidised beds. Interaction between bed material and fuel may influence the result. In Paper II, however, ash samples were used except for two samples where fuels were used. Since the most dominating ash-forming elements in RCG often are  $SiO_2$ ,  $K_2O$ , and  $CaO$ , the phase diagram and chemical equilibrium model calculations seem to be a useful screening method to predict melting behaviour of RCG from different growing sites. Table 4 shows the elemental composition of ash in percent ( $SiO_2$ ,  $CaO$ ,  $K_2O$ ) for RCG samples from different growing sites in Sweden. The results show that for RCG with high ash content these elements often constitute up to above 90 wt-%. In a study by Skrifvars et al. (1998), multi-component and multiphase thermodynamic equilibrium calculations confirm that silicate melt seem to form the major part of melt in RCG.

Another method that has been tested on RCG is the compression strength test where a laboratory ash is pelletised and heated in dry air atmosphere. After cooling, the pellets are tested for their compression strength, which is a measure of the sintering degree (Skrifvars, Backman & Hupa, 1998), (Skrifvars et al. 1999). These tests also show that sintering starts at far lower temperatures than what the ASTM method shows.

Table 4. *Fuel analysis of reed canary grass from different growing sites. Elemental composition of ash in percent.*

Growing Site	Ash content %	SiO <sub>2</sub> %	CaO %	K <sub>2</sub> O %
Alftal	7	83	4	3
Eskilstuna	12	91	2	1
Burträsk	2	74	7	4
Enköping	11	89	2	2
Hofors	7	87	3	2
Hudiksvall	6	84	3	3
Lomma	7	78	4	4
Lund	5	77	4	7
Ockelbo	7	86	3	2
Sandviken	5	82	4	2
Sundsvall	4	77	4	5
Såtenäs	7	84	3	4
Grubbe	8	87	2	2
Västerhan	4	63	11	7
Bjästa	3	66	9	9
Uppsala	12	90	2	1
Vålberg	8	86	3	2
Glommerträsk	3	63	12	6

### Physical characteristics

As a guideline for both producers and users, a Swedish standard has been developed for classifying the quality of pellets (SS 18 71 20) and briquettes (SS 18 71 23). The standard involves both chemical and physical characteristics. The physical characteristics include dimensions (diameter and length of a pellet or briquette), bulk density, and mechanical strength (Table 5). Since different heating systems require different fuel qualities, the standards include three groups. For pulverised biomass fuels, there are no Swedish standards but important characteristics are particle size distribution, particle shape, bulk density, and handling characteristics such as bridging tendency.

#### *Characterisation methods.*

**Briquettes and pellets.**

According to Swedish standard, the raw bulk density of briquettes and pellets defines the raw bulk density loaded in a large container on a vehicle. That is, a container with a measured volume loaded with fuel. The volume is measured and the container is weighed before and after unloading. There are no standards for raw bulk density measured in a laboratory. In Paper I, the bulk density of RCG briquettes was measured by weighting the material in a 20-l vessel. The briquette unit density was calculated by volume measurement and weighing.

Mechanical strength describes the amount of fines returning from briquettes and pellets after being subjected to mechanical force in a rotating drum equipped with a sieve. For briquettes, the sieve size is 15 mm; for pellets, the sieve size is 3 mm. After rotating for 8 minutes for pellets and 4 minutes for briquettes, the amount of fines is weighed. This standard was established in 1999 (involving both briquettes and pellets). In Paper I, however, the mechanical strength was determined

according to Swedish standards: (SS 18 71 75:1) and (18 71 74:1). That analysis is performed using a rotating drum for 8 minutes. The material is then sieved using sieve size 45, 15, 5, and 3 mm. The European committee for standardization (CEN) is now working with a technical specification for a method used for testing the mechanical durability of pellets and briquettes.

Table 5. *Physical characteristics included in the Swedish standard (SS 1871 20), (SS 18 71 23) for briquettes and pellets.*

Parameter	Standard	Unit	Group 1	Group 2	Group 3
<i>Briquettes</i>					
Diameter <sup>1</sup>		mm	min. 25	min. 25	min 25
Length <sup>1</sup>		mm	>1/2Ø but max. 300	min 10 and max 100	Indicates
Bulk density	SS 18 71 78	kg/m <sup>3</sup>	≥550	≥450	≥450
Mechanical strength/fines	SS18 71 80	% < 15 mm	≤ 8	≤ 10	≤ 10
<i>Pellets</i>					
Diameter <sup>1</sup>		mm	Indicates	Indicates	Indicates
Length <sup>1</sup>		mm	max. 4 x Ø	max 5 x Ø	max 5 x Ø
Bulk density	SS 18 71 78	kg/m <sup>3</sup>	≥600	≥500	≥500
Mechanical Strength/fines	SS 18 71 80	% < 3mm	≤ 0.8	≤ 1.5	≤ 1.5

<sup>1</sup> Measurement of 10 briquettes or pellets.

#### Powder

Particle size can be measured by a variety of methods. The method should measure the size that is most relevant to the process under study. For wood powder fuel, dry sieving is used most often. Other techniques such as laser diffraction and image analysis have also been examined (Paper III, Almcrantz & Karlsson, 2001). Each technique measures a different property of a particle. Figure 20 shows that the particle size distribution measured by sieve analysis and laser diffraction gave different distribution curves but the same relative result. This means that there cannot be a particle size standard for particles from pulverised fuel, unless the method to be used is specified.

In order to control the production, handling, and combustion process of biomass powder, informative and simple characterisation methods need to be developed. Today there are no standards for sieving pulverised biomass fuels, but the European committee for standardisation (CEN) is now working with a technical specification. For laser diffraction, international and national standards that analyse particulate materials in dry and wet forms have been established (Xu, Andreina & Guida, 2003). For image analysis, a British standard (BS 3406, part 4) is established as a guide to microscope and image analysis methods. Standards for powder sampling can also be found (BS 3406, part 1), which is a most important step for particle analysis.

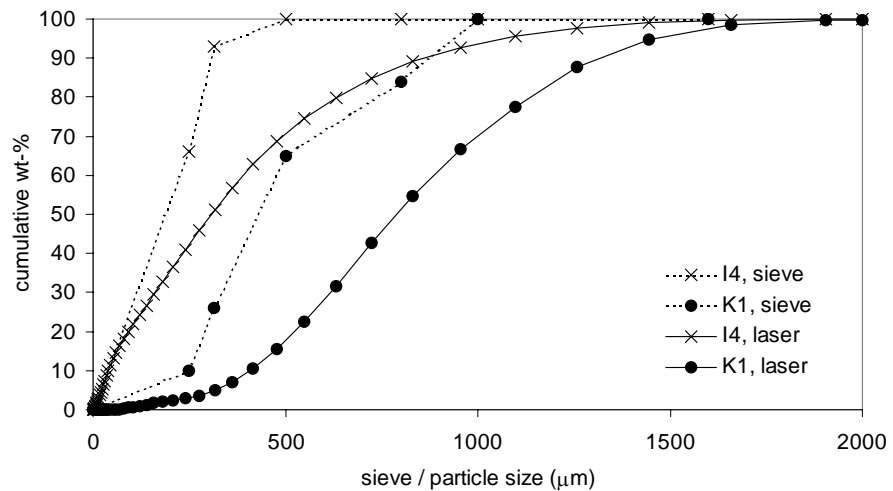

Figure 20. Particle size distribution measured by sieve analysis and laser diffraction. Wood powder cut in knife mill (K1) and hammer mill (I4).

One of the most widely used methods to determine handling characteristics is to measure flow properties. Theories on flow and bridging in particulate solids and techniques for design of bins and hoppers are presented in several studies. However, several of these studies are based on the assumptions that the particles should be small compared to the openings, regular in shape, and the material should not be elastic. Consequently, these methods are not suitable for elastic powders with fibrous and irregular particle shape, which is the case for wood powder fuels (Paper III). A common method used for biomass fuels are instead different bridging apparatus methods where a tendency to bridge over outlet openings is studied (Bernhardt, 1999; Mattsson & Kofman, 2002; Paper III).

### Sieving

Sieving is one of the oldest methods used for particle size analysis. Since it is a simple method and the investment cost is low, it still is a widely used method. Sieving is also the most common quality control method used in commercial fuel powder plants. The principal of sieving is that a sample is subjected to sieving through horizontally vibrating sieves, sorting the particles in decreasing size classes by manual or mechanical means. The size distribution is measured by mass. Many parameters affect sieving (Leschonski, 1979; Rawle, 2001): sample size, vibration of sieves, vibration time, shape of particles, and moisture content. Too much powder will prolong the sieving process and affect the result because small particles block the screening surface and reduce the sieve size. The efficiency of grading of a sample will depend on the vibration of the sieves. The passage of particles through a sieve will depend on the shape of the particles and the shape of the sieve. Spherical particles tend to blind the sieves and fibrous, narrow particles tend to go unimpeded through sieves. The perfect sieve has openings of equal shape and size. In practise, the sieve holes may not have the

same size because of damage. Electrostatic charging may also cause agglomeration. However, sieve analysis is a simple method for comparing the same type of the material in the production process, and it produces relative data regarding changes in size distribution (Paper III). To produce accurate comparable results from sieve analysis, sieve sizes, measurement times, and operation methods need to be standardised.

#### Image analysis

With increasing quality control in many industrial fields, the use of a size parameter to describe the physical dimensions of particles is often insufficient, especially for non-spherical particles. Consequently, the demand for shape analysis has increased. Image analysis makes it possible to study single particles as well as sets of particles. For each particle, size parameters (area, length, width, etc.) are measured and shape parameters such as the ratio of width and length are calculated. The result still depends on a particle's orientation, but the images are analysed individually without any assumption of particle shape.

Traditionally, particle shape measurements have involved microscopy because of the large amount of information it provides. However, for statistical significance, large numbers of particles need to be characterized and this combined with sample preparation is very time consuming. Automatic image analysis is now being used in most of the newly developed methods of characterising shape that are being reported (Xu, Andreina & Guida 2003). There are several different instruments available, but most methods use a CCD video camera to take digitised video images. The video camera can scan the sample in a pre-programmed way by moving in different directions and a new image is acquired for each movement. The video camera can also be connected to a microscope and the sample is moved manually, which decrease the number of particles analysed and increase the time for analysing (Paper III). The image is then treated for enhancing contrast and removing noise. The next step is to segregate the image from background, resulting in a binary black and white image. Then touching particles can be segregated. This process is automatic and the software makes direct measurements of pre-defined morphological parameters such as length, width, diameter, and area. An image analysis system may be totally automatic where a large amount of particles can be analysed in a short period of time. For example, a modern image analyser analyses around 20,000 particles in approximately 10 minutes. Figure 21 shows example of different particle shapes for wood powder.

Sample preparation can be achieved in different ways. A common method is to use glass slides where the particles are dispersed in a mono-layer. This can be done manually or by using a sample preparation device (Paper III, Parmavision 830). Other methods used are powder feeders that allow the powder to freely fall in front of the camera (Almcrantz & Karlsson, 2001).



Figure 21. Example of different particle shapes for wood powder.

Interpretation of data may be a problem dealing with large number of variables. However, by using principal component analysis (PCA), the variation in data may be described in a few principal components. PCA is a projection method that graphical describes major variation/co-variation patterns in multivariate data. In the PCA analysis, all variables (size parameters and shape factors) for all objects (fuel samples) can be simultaneously taken into account for the analysis (Paper **III, IV**).

#### Laser diffraction

In particle sizing laser diffraction has become a most popular characterisation technique, replacing sieving in many fields. The principal for laser diffraction is that particles are passed through a focused laser beam, either as a spray for aerosols, dry blown dry powder, or dispersed in a fluid suspension. The particles scatter light at an angle that is inversely proportional to their size. The angular intensity of the scattered light is then measured by a series of photosensitive detectors and the particle size is calculated using a scattering model, Fraunhofer and Mie light scattering theories (Rawle, 2001). The optical models assume that the particles are spherical and that the result is independent of how the light hits the rotating particle. The laser diffraction instrument measures in the range from 0.1-2000  $\mu\text{m}$ , and it produces results in a couple of minutes. It is a highly reproducible technique; however, the method underestimates large particles if they are few and a dependency of particle shape is obtained. Laser diffraction yields larger mean sizes as well as broader distributions as the shape of the particles more



and more differ from that of a sphere (Natito et al., 1998; Ma et al., 2000; Xu, Andreina & Guida, 2003).

#### Tendency to bridge

Different bridging apparatus methods can be used for biomass material where tendency to bridge over outlet openings is studied. An apparatus can be designed like a cone, pyramidal, or other with a converging section (Figure 22a) (Paper III). An apparatus can also be based on a flat-bottomed slot chute opening that has no angle of converging section to take into account (Figure 22b) (Bernharddt, 1999), or on a flat-bottomed slot opening that has no wall frictions and angle of converging section to take into account (Figure 22c) (Mattsson & Kofman, 2002), (Mattsson, 1990).

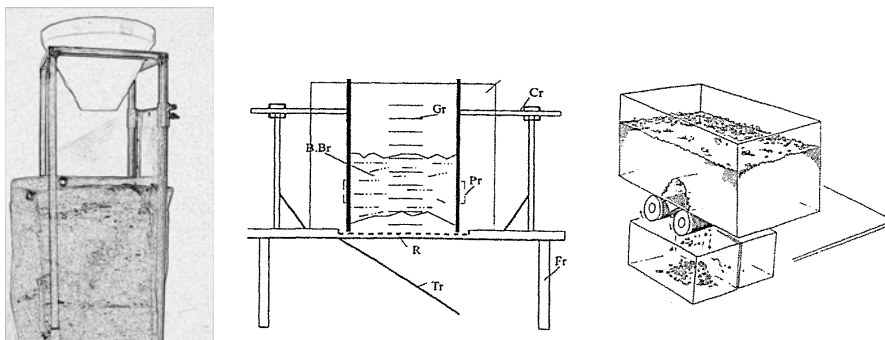

Figure 22 a-c. Illustrations of different types of bridging apparatus used for biomass.

The measurement principle is based on how wide an opening needs to be to break the bridge of fuel particles over the opening. The disadvantage of the principle in Figure 22a and 22b is that bridging of a fuel depends not only on the fuel properties but also on the friction between fuel and wall, the shape of the opening, and the angle of the converging section. Using the apparatus in Figure 22c, the differences in required slot opening will depend only on the fuel properties.

In Paper III, wood fuel powder cut in various types of impact mills and knife mills was characterised using sieve analysis, laser diffraction, image analysis, and a funnel method for measuring the tendency to bridge (Figure 22a). The particle size analyses gave similar results and gave the same relative picture of particle size distribution in the tested powders. However, the studied methods gave different size distribution curves because the techniques measure different size properties (Figure 20). Both sieve analysis and laser diffraction showed that impact mills produced wood powder with more fine particles than wood powder produced by knife mills. Image analysis showed that particle sizes and shapes differed between the two types of mills.

Paper III also describes the bridging tendency, measured as the size of a funnel opening needed for the powder to pass freely (Figure 22a). The results from these analyses showed that the bridging tendency was higher for powder produced by

impact mills than by knife mills (Table 6). The results showed that a higher weight percentage of smaller particle sizes typical for the powders milled by impact mills increased the tendency to bridge and large particles typical for the powders milled in knife mills decreased the tendency to bridge. Shape factors typical for the powder from the two mill-types were also important for the results.

*Table 6.* Critical opening needed to avoid bridging (passes through a funnel five out of five tries).

Powder sample	Funnel diameter mm	Mill type
I1	155	Impact mill
I2	150	Impact mill
I3	150	Impact mill
I4	155	Impact mill
I5	145	Impact mill
K1	85	Knife mill
K2	110	Knife mill

Several factors depend on the method that analyses particle properties of biomass powder. Sieving is the method mainly used today since it is a simple and cheap method. However, results depend not only on the size of the particles but also on their shape and the operation methods. Even if the analysis is standardised, it may be difficult to compare sieve analysis results from one user to another. Since the instrument used for laser diffraction analysis and image analysis are expensive, sieving is necessary even if the method needs further development and to be standardised. The method may be suitable for comparing the same type of material in the production process and to find divergences in the final product.

The most suitable method to describe particle properties of biomass powder discussed in this thesis is probably image analysis. It is the only method that measures both size and shape, and it is possible to look directly at the particles in question. With new improved instruments available, a large amount of particles can also be analysed in a short period of time. Compared to other industrial areas such as the food industry and pharmaceutical industry the use of image analysis in the energy sector is so far very limited. There are few studies where image analysis has been tested for biomass fuels and compared to other methods (Ryk, 1995; Almcrantz & Karlsson, 2001; Paper III). A recent study concluded image analysis as the most suitable method compared to sieving and laser diffraction (Almcrantz & Karlsson, 2001).

Paper III indicates that funnels could be used to give relative estimations of the tendency to bridge. However, the method needs to be developed further. The disadvantage with the funnel method is that bridging depends on several parameters such as the friction between fuel and wall, the shape of the opening, and the angle of the converging section. A method where the comparison of fuels can be based on the opening needed to let the fuel pass may be a more suitable method (Mattsson & Kofman, 2002). However, the method used by Mattsson & Kofman was constructed for larger quantities of fuel and mainly for chopped fuel. This method should be interesting to apply on laboratory scale equipment for powder analysis and evaluate for smaller fuel samples for laboratory use.

### *Effects of fuel characteristics on handling properties*

#### Briquettes and pellets

Different heating systems require different fuel quality. For large heating plants that are equipped with more sophisticated flue gas cleaning, and combustion and process control systems, the physical properties of briquettes and pellets are usually less important compared to pellets used in stoves for residential heating.

The dimensions of the pellets and briquettes are important factors with respect to feeding properties and combustion. Studies show that pellets with a smaller diameter produce a more efficient combustion, especially in small furnaces (Bachs et al., 1999). The length of briquettes and pellets may affect the fuel feeding properties. A shorter briquette or pellet may give a more continuous flow.

The bulk density mainly affects the transport and storage efficiency. A low bulk density has a negative effect on the energy density and therefore on the transportation costs and the storage capacity both for the pellets producer and the end user.

A high share of fines in the storage system of the end user can cause problem in the feeding system, and it may constitute a health risk for those who handle the fuel especially for small pellet stoves. In addition, a high share of fines also increases particle emissions during combustion (Oberberger & Thek, 2002).

#### Powder fuels

In a process in which a powder fuel has to be stored and removed from storage and transferred to some other place different problems can arise. If the powder fuel is stored in a silo and an aperture in its base is opened, then there may be no discharge of material or discharge may begin and then stop for no apparent reason before the silo is empty. If the material is conveyed pneumatically through pipes, then it cannot be assumed that the material will flow continuously even if the pipes are vertical.

There are several parameters known to affect particulate fuel's tendency to flow and bridge, and this includes particle size and shape. The influence of particle size and shape on the tendency to bridge is confirmed by several studies (Mattsson, 1990, 1997; Mattsson & Kofman, 2003; Paper III). Reported results show that as particle size decreases, the cohesion increases and the particles stick together more easily (Abdullah & Geldart, 1999), (Paper III). Particle shape is also important. The inter-particle force between for example a sphere and a plane surface is higher than between two equally sized spheres (Williams, 1995). Mattsson et al. (2002) have studied bridging tendency of several different biofuels: chopped RCG, straw, wood chips, pellets and wood powder showed that particle shape such as long and thin particles and low bulk density increased the tendency to bridge. In Paper III, it was demonstrated that particle size and shape influenced bridging tendency. The dominating factors that effected the tendency to bridge were particle size (800 and 315  $\mu\text{m}$  according to sieving) and shape factors (circularity and particle roughness).

### *Effects of fuel characteristics on emissions during combustion*

The effect of physical fuel quality on emissions cannot be defined without referring to the heating technology. The low NO<sub>x</sub> combustion technologies that are used for fuel powders have the disadvantage that there is a strong relation between NO<sub>x</sub> emissions and burnout. With air staging, it is possible to achieve lower NO<sub>x</sub> emissions, but it may also result in an increased carbon content in ash and increased unburned pollutants. An alternative to decreasing this interdependence is to examine the effect of particle properties. The size and shape of particles influence their trajectories and their residence times in the near burner region and since the environment in which volatiles are released affects NO<sub>x</sub>, a relation can be assumed between particle properties and NO<sub>x</sub> emissions. Figure 23 and 24 show predicted particle trajectories from numerical simulations on a wood powder flame. Following a particular particle trace, the colour indicates the current burning stage for the particles at a particular location in the experimental furnace used (Paper **IV**). In Figure 23 small particles (0.125 mm) according to sieving burn close to the burner inlet and all particles are carried out of the furnace chamber by exhaust gas flow (char combustion completed). The large particles (0.65 mm) (Figure 24) start to burn further away from the burner inlet due to increased evaporation/boiling times and thus require longer residence time to complete the combustion (char combustion not completed).

Burner air staging generally produces higher NO<sub>x</sub> emissions for smaller particles, whereas the ignition time and unburned pollutants are decreased (Reuther, Karsner & Jack, 1982; Duxbury & Welford, 1989; Abbas, et al., 1994; Van der Lans, Glarborg & Dam-Johansen, 1997; Paper **IV**). Reuther (1982) showed that decreasing the mass-mean particle size of bark powder from 300 µm to 125 and 74 µm resulted in an increase in NO<sub>x</sub> from 150 to 290 to 300 ppm respectively.

Studies on the effect of particle shape on emissions are very limited. An explanation for this may be that it is more complicated to do shape analysis. Secondly, particle characteristics are mill-type specific and different types of mills and sieves are needed to achieve different particle shapes for the same type of raw material (Paper **III**). However, the particle shape is important for the aerodynamic properties. Thick and heavy particles require longer residence time to complete the combustion, and they more easily get trapped at the bottom of the combustion chamber compared to thin particles with large surface with respect to their mass (Paper **IV**).

In Paper **IV**, wood fuel powder cut in different mills was combusted in a 150 kW powder burner to study NO<sub>x</sub>, CO, HC, furnace temperature, and burnout as a function of particle size distribution and particle shape. The results showed that particle characteristics affected fuel feeding, ignition, unburned pollutants, furnace temperature, and the content of unburned matter in ash. CO emissions and content unburned matter in ash shows a better burnout for a finely milled powder. The temperature in the front combustion section was almost 200°C higher for the fuel with most fines than for the fuel with least fines. The effect of fine grinding is an

increased reactive particle surface, resulting in rapid ignition combined with higher temperature in the front combustion section.

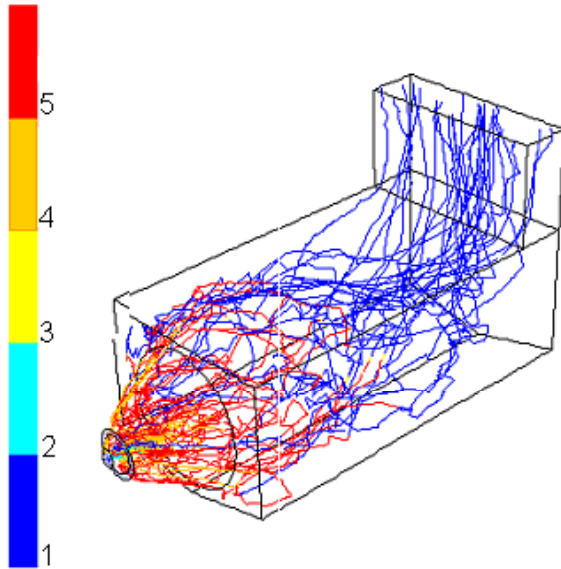

Figure 23. Predicted particle traces (particle size 0.125 mm) for wood powder. Coloured by Law Index: 1. heating/cooling; 2. evaporation; 3. boiling; 4. devolatilisation and 5. char combustion.

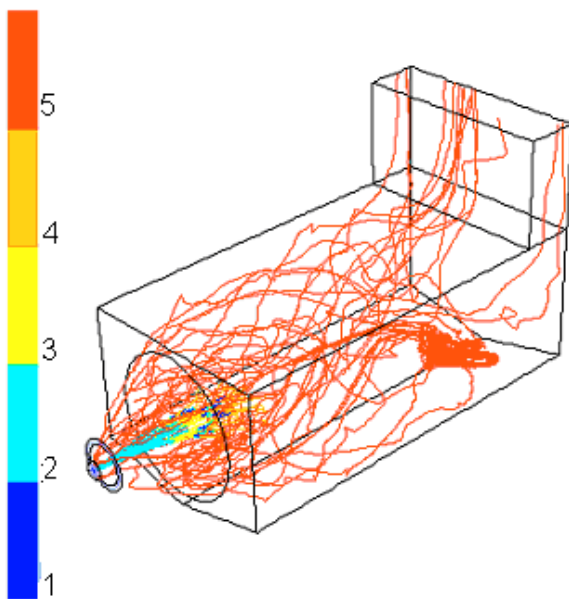

Figure 24. Predicted particle traces (particle size 0.65 mm) for wood powder. Coloured by Law Index: 1. heating/cooling; 2. evaporation; 3. boiling; 4. devolatilisation and 5. char combustion.

Particle characteristics had a weak influence on NO emissions compared to fuel nitrogen, which had a strong influence on NO emissions. Fuel powder with higher levels of smaller particles produced slightly higher NO emissions, and powder with higher amounts of larger particles produced slightly lower NO emissions. For a finely milled powder the fuel-nitrogen release might be greater than for a coarsely milled powder. In addition, for the finely milled powder, small levels of thermal NO<sub>x</sub> might locally be formed due to fast combustion and increased temperature in the front combustion zone. In this study, the differences in particle size was rather small compared to for example Reuther's study and a higher level of smaller particles might have further increased the NO emissions.

## **Experimental design and data analysis**

The purpose of using experimental designs is to get a lot of information from as few experiments as possible. In this work, experimental designs were found to be useful in Paper **IV**. This study examines emissions as a function of fuel properties and air flows by using a powder burner. The air flows included were primary air, secondary air and tertiary air, and the sum of these flows add up to 100%. In the experiments, fuels with different physical properties (particle size and particle shape) were used. Thus, for these experiments a combined design with process and mixture factors in the same experimental plan was needed. In this case, a computer-generated D-optimal design is useful. D-optimal designs choose samples from a set of possible runs (candidate set) and maximise the variance in the variables of the selected samples (Eriksson et al., 2000). The software used was Modde 6.0 (Umetrics AB, Umeå Sweden).

In image analysis, many variables describing the samples can be measured and describing all these data in a simple way might be a problem (Paper **III** & **IV**). One solution is to use multivariate projection methods. Here all measured variables (particle size and particle shape) for all fuel samples are analysed simultaneously. Principal Component Analysis (PCA) gives a general overview of multivariate data, and interpretable plots of data can be obtained. PCA provides possibilities to find patterns and trends in data as well as to interpret which variables contribute most strongly to the patterns and trends (Eriksson et al., 2001). The software used was Simca 10.0 (Umetrics AB Sweden).

Partial least squares (PLS) is a regression extension of PCA and used when looking for a relationship between two data blocks of variables, X and Y (Eriksson et al. 2001). In Paper **III** particle size distribution, particle shape, moisture content, and bulk density (x variables) were correlated to the result of the tendency to bridge (y-variable). In Paper **IV** PLS was used to relate particle size distribution, particle shape, and air flow settings (x variables) to emissions and furnace temperature (y variables). The software used was Simca 10.0 (Umetrics AB Sweden).

## Conclusions and future research

This work investigates the effect of fuel quality on processing, handling characteristics (bridging), combustion (emissions), and ash melting, using upgraded biofuels. Fuel quality defines the fuel's chemical and physical characteristics. The chemical characteristics depend on, for example, raw material and growing conditions while physical characteristics describe parameters affected by the type of processing the fuel has undergone, such as particle size and particle shape. In Paper **I** and **II**, some aspects of how the chemical characteristics of RCG effect briquetting, combustion, and ash melting were studied. In Paper **III** and **IV**, some aspects of how particle characteristics of wood powder effects bridging and combustion were studied. The conclusions from this work are:

- The growing conditions effect the chemical composition of spring harvested RCG. RCG grown on clay rich soils has a higher ash content compared to RCG grown on humus rich soils (Paper **I**).
- RCG seems be a suitable raw material for briquetting and the results imply that variation in ash content does not affect the briquette product (Paper **I**).
- Combustion experiments imply that RCG can be burned with good result in combustion equipment that is designed for high ash contents and sintering tendency. The variation in ash content does not effect the flue gas emissions (Paper **I**).
- The most dominating ash forming elements in RCG are Si, K, and Ca. Estimations of melting behaviour imply that RCG with low ash content (3-4%) has a higher tendency to melt in a temperature range <1200°C) due to higher content of K and lower content of Si. For high ash content fuels (>5%), an increased melting seems to occur in a higher temperature range, (>1500 °C) (Paper **II**).
- Different types of mills produce wood powder with different particle size distributions and particle shapes. Impact mills produce wood powder with more fine particles than wood powder produced by knife mills (Paper **III**).
- There are various methods to determine these particle characteristics but image analysis must be used to analyse particle shape (Paper **III**).
- The difference in tendency to bridge seems to be a combined effect of particle size and shape characteristics. The tendency to bridge is higher for fuels produced in impact mills (Paper **III**).
- Particle characteristics due to mill type and milling degree affect fuel feeding and ignition. They also affect unburned pollutants, furnace temperature, and the content of unburned matter in ash during powder combustion (Paper **IV**).
- An increased content of smaller particles negatively affects the fuel feeding and NO emissions (are slightly increased), while it has a positive effect on ignition, unburned pollutants (decreased) and the content unburned matter in ash (decreased) (Paper **IV**).

Concerning future developments for the use of spring harvested RCG as an upgraded fuel, it is likely to involve more pelletising and the use as powder fuel. Pellets production dominates the market and most pellets are used as powder fuel. It is of interest to further study how different growing sites and soil types affect fuel quality. A pellets production line demands large volumes of raw material and the RCG must probably be collected from different growing sites. More studies on ash melting behaviour is therefore important to guarantee the fuel quality. The risk for sintering might be higher for RCG and further ash melting studies when RCG is mixed with wood is also needed. The combustion equipment used for wood powder today is not designed for large volumes of ash, especially concerning the electric filters. More simple and reliable methods for prediction of ash melting behaviour needs to be developed. Another area that might be of interest to study is the use of additives, especially when using RCG as powder fuel.

Particle characteristics are most important concerning wood powder combustion. Various methods can determine particle size distribution, but all of these methods are not developed for biomass powder. More research is needed to find suitable on-line methods for quality assurance and individual adaptation of fuel quality to various customers. For example fast image analysis and NIR-analysis. Today most fuel powder is stored and transported as pellets, and there is a need to find methods to characterise particle properties of pellets when they will be used as fuel powder. This is especially true since several combustion plants are using roller mills where the material is crushed. Further studies are needed to find out which milling methods that are optimal for biofuel pellets used as powder.

Another field for further research is to decrease unburned pollutants and NO<sub>x</sub> emissions during powder combustion. Using wood residues, NO<sub>x</sub> emissions today are less of a problem compared to unburned pollutants. However, with an increasing use of upgraded biofuels other raw materials with higher nitrogen content like RCG will be used and the demand for decreasing NO<sub>x</sub> emissions will increase. In this work, it was assumed that NO emissions were released from the nitrogen in the fuel. However, in future experiments it is of interest to examine if thermal NO<sub>x</sub> is formed. This can be accomplished by running experiments both with air and with a synthetic mixture of inert argon and oxygen (Öhman & Nordin, 1995).

## **Acknowledgement**

I wish to express my sincere gratitude to everyone who has helped me in preparing this thesis and I especially would like to thank the following people.

First of all I want to thank my supervisor, Calle Nilsson for your good advice and for stimulating discussions. Thanks to my co-supervisor Jan Erik Mattsson for your participation in my research.

Thanks to all the colleagues at SLU Rönneby, especially my colleagues at the Unit of Biomass Technology and Chemistry. Helen Bergner, thank you for helping out with the image analysis and other laboratory assistance. Paul Geladi for helpful comments on data analysis. Jan Burvall for helping me in Bureå and many



other places, for interesting discussions and good travel company to Germany. Mehrdad Arshadi thanks for your assistance with the powder combustion tests. Thanks to the staff at BTC, Håkan Örberg, Gunnar Kalén and Mikael Thyrel for your assistance with the combustion experiments at BTC.

Marcus Öhman, Umeå University, thank you for being there for my questions and thanks for always have the time to read my work and give good advice.

Thanks to the staff at the pellets mill in Överklinten, the pellets mill in Bureå, Fransson in Sundsvall, Rapid Granulator, Bredaryd, Björn Hedman, Umeå University and all others that helped me with milling, briquetting and pelletising of RCG. Thanks to the staff at SMP, Umeå. Tage thank you for giving me technical support whenever needed. Thanks to the staff at ETC, Piteå for all help with my combustion experiments. Ulf Nordström, thanks for all work with the combustion equipment and for giving me technical support at ETC. I would like to thank all the participants of the EU reed canary-grass project.

Anton, my dear husband, thank you for giving me all the time I needed to accomplish the thesis. I also want to thank my wonderful children Vilgot and Elis (who were born during the work on my thesis) for their patience during the final preparation.

This research was financially supported by the National research programme on energy grass (grants from SLF, NUTEK and Vattenfall AB) and by the Swedish national Energy Administration.

## References

- Abbas, T., Costa, M., Costen, P., Godoy, S., Lockwood, F.C., Ou, J.J., Romo-Millares, C. & Zhou, J. 1994. NO<sub>x</sub> formation and reduction mechanisms in pulverized coal flames. *Fuel* 73(9), 1423-1436.
- Adams, T.N., Raymond, D.R. & Schmid, C. 1988. Optimization of a swirl burner for pulverized wood fuels. *Tappi Journal*, May, 91.
- Almcrantz, A. & Karlsson, M. 2001. Storleksbestämning av träpulver. *Ingenjörshögskolan, Jönköping*, Examensarbete.
- Bachs, A., Dahlström, J.E., Persson, H. & Tullin, C. 1999. Eldningstester med olika pelletskvalitéer. *Energimyndigheten, Eskilstuna*. Rapport ER 7:1999.
- Backman, R. & Nordin, A. 1998. High temperature equilibrium calculations of ash forming elements in biomass combustion/gasification system-state of art, possibilities and applications. *Proceedings. International Biomass Ash Workshop*, October 1-2, Graz, Austria.
- Baxter, L., Miles, T., Miles Jr, T., Jenkins, B., Milne, T., Dayton, D., Bryers, R. & Oden, L. 1998. The behavior of inorganic material in biomass-fired power boilers:field and laboratory experiences. *Fuel Processing Technology* 54, 47-78.
- Bernhardt, W. 1999. Handling properties of sugar cane bagasse-Part III:The phenomenon of bridging. *Zuckerindustrie* 124(1), 456-461.
- Bhattacharya, S.C., Sett, S., Shrestha, R. 1989. State of the Art for Biomass Densification. *Energy Sources* 11, 161-182.
- Bhattacharya, S.C. 2002. Biomass Energy Use and Densification in Developing Countries. *Abstract of the first world conference on pellets*, Stockholm, 2-4 September 2002.

- Bioenergy International. 2003. Finnish company Vapo expands in pellets production. No 5, p 13, July 2003.
- Burvall, J. 1993. Tillverkning och proveldning av rörfilenpulver-ett fullskaleförsök. *Sveriges Lantbruksuniversitet, Umeå, Röbbäcksdalen meddelar, rapport 9, 1993.*
- Burvall, J. & Örberg, H. 1994. Brikettering av rörfilen. Teknik och ekonomi. *Sveriges Lantbruksuniversitet Umeå, Röbbäcksdalen meddelar, rapport 10:1994.*
- Burvall, J. 1997. Influence of harvest time and soil type on fuel quality in reed canary grass (*phalaris Aruninacea L. Biomass and Bioenergy 12(3)*), 149-154.
- Carre, J., Hebert, J., Lacrosse, L. & Schenkel, Y. 1988. Technical and economic constraints of biomass briquetting. *European symposium on soft energy sources at the local level, Greece, Naxos, August 29-September 2, 1988.*
- Coin, C., Kahraman, H. & Peifenstein, A. 1995. An improved ash fusion test. In: Baxter, L, Desollar, R, editors. *Applications of Advanced Technology to Ash-Related Problems in Boilers. New York, Plenum Press, 187-200.*
- Duxbury, J. & Welford, G.B. 1989. The effect of particle size on NO<sub>x</sub> emissions during the firing of pulverised coal in a shell boiler. *Journal of the Institute of Energy, 452, 147-151.*
- Eklund, A. 2002. Marknadsstudie av låg NO<sub>x</sub>-brännare för olja, gas och träpulver. *Värmeforsk Stockholm, rapport 782.*
- Eriksson, L., Johansson, E., Kettaneh-Wold, N. & Wold, S. 2000. *Design of Experiments:Principals and Applications.* Umetrics Academy ISBN 91-973730-0-1.
- Eriksson, L., Johansson, E., Kettaneh-Wold, N. & Wold, S. 2001. *Multi and Megavariate data analysis. Principles and applications.* Umetrics Academy ISBN 91-973730-1-X.
- Eriksson, S. & Prior, M. 1990. The briquetting of agricultural wastes for fuel. *FAO, Environment and Energy Paper 11.* 131 pp. Rome.
- Finell, M., Nilsson, C., Olsson, R., Agnemo, R. & Svensson, S. 2002. Briquetting of fractionated reed canary-grass for pulp production. *Industrial Crops Products 16, 185-192.*
- Gibbs, J. W. 1874. Equilibrium of heterogeneous substances. *Trans. Conn. Acad. Sci., 3, 108-248, 343-524, (1874-78).*
- Glarborg, P., Jensen, A.D. & Johansson, J.E. 2003. Fuel nitrogen conversion in solid fuel fired systems. *Progress in Energy and Combustion Science 29, 89-113.*
- Grover, P.D. & Mishra, S.K. 1996. Biomass briquetting: technology and practices. *FAO. Regional wood Energy Development Programme in Asia.* Document No. 46. 46 pp. Bangkok.
- Haaker, A. 2002. Avedore 2 största biokraftvärmeverket. *Bioenergi 6, 8-9, 11.*
- Hadders, G. & Olsson, R. 1997. Harvest of grass for combustion in late summer and in spring. *Biomass and Bioenergy 12(3), 171-175.*
- Hansen, L., Frandsen, F., Dam-Johansen, K. & Sorensen, S. 1999. Quantification of fusion in ashes from solid fuel combustion. *Thermochimica Acta 326, 105-117.*
- Hansson, U. 2003. Smältförlopp hos bibränsleaskor i oxiderande respektive reducerande miljö. *Sveriges Lantbruksuniversitet, enheten för biomassateknologi och kemi, Umeå, BTK-students report no. 8.*
- Himmel, M., Tucker, M., Baker, J., Rivard, C., OH, K. & Grohmann, K. 1985. Comminution of Biomass:Hammer and Knife mills. *Biotechnology and Bioengineering Symp. No. 15, 41-58.*
- Hjuler, K. 2000. Ash fusibility detection using image analysis. Proceedings from 1<sup>st</sup> world Conference on Biomass for Energy and Industry. Sevilla, Spain, 5-9 June, 2000.
- Hopstadius, M. & Sandström, J. 2002. Fukthaltens och malningsgradens betydelse vid pelletering av bibränslen. *Sveriges Lantbruksuniversitet, enheten för biomassateknologi och kemi, Umeå, BTK-students report 7.*
- Huffman, G., Huggins, F. & Dunmyre, G. 1981. Investigation of the high temperature behaviour of coal ash in reducing and oxidizing atmospheres. *Fuel 60, 585-597.*
- Jenkins, B.M., Baxter, L.L., Miles, T.R., & Miles, T.R. 1998. Combustion properties of biomass. *Fuel Processing Technology 54(1-3), 17-46.*
- Johansson, J. & Lundqvist, U. 1999. Estimating Swedish biomass energy supply. *Biomass and Bioenergy 17, 85-93.*

- Kastberg, S. & Burvall, J. 1997. Perennial rhizomatous grass - Reed canary grass as an upgraded biofuel, experiences from combustion tests in Sweden. *Proceedings from International Conference on Sustainable Agriculture for Food, Energy and Industry*. Braunschweig, June 1997.
- Kastberg, S & Nilsson, C. 2000. Combustion optimisation study of biomass powder. *Proceedings from 1 st World Conference on Biomass for Energy and Industry*. Sevilla, Spain, 5-9 June, 2000, 890-892.
- Landström, S., Lomakka, L. & Andersson, S. 1996. Harvest in spring improves yield and quality of reed canary grass as a bioenergy crop. *Biomass and Bioenergy* 11(4), 333-341.
- Larsson, S. 2003. Modelling of the Potential for Energy Crop Utilisation in Northern Sweden. *Thesis of Licentiate, Swedish University of Agricultural Sciences, Umeå, 2003*.
- Ledin, S. 1996. Willow wood properties, production and economy. *Biomass and Bioenergy* 11, 75-83.
- Lehtikangas, P. 2001. Quality properties of pelletised sawdust, logging residues and bark. *Biomass and Bioenergy* 20, 351-360.
- Leschonski, K. 1979. Sieve analysis, the cinderella of particle size analysis methods. *Powder Technology* 24, 115-124.
- Lewandowski, I., Scurlock, J., Lindvall, E. & Christou, M. 2003. The development and current status of perennial rhizomatous grasses as energy crops in the US and Europe. *Biomass and Bioenergy* 25, 335-361.
- Li, Y. & Liu, H. 2000. High-pressure densification of wood residues to form an upgraded fuel. *Biomass and Bioenergy* 19, 177-186.
- Lundberg, H. 2002. Combustion of Crushed Pellets in a Burner. *Abstract of the first world conference on pellets*, Stockholm, 2-4 September 2002.
- Löfgren, B.E. 2001. Elda spannmål i Baxi Multiheat 2,5. *Åfab Lidköping*, rapport 01-02, 22 maj 2001.
- Löfgren, B.E. 2002. Pellet-burners for Small Houses:an Overview. *Abstract of the first world conference on pellets*, Stockholm, 2-4 September 2002.
- Ma, Z., Merkus, H., de Smet, J., Heffels, C. & Scarlett, B. 2000. New developments in particle characterization by laser diffraction: size and shape. *Powder Technology* 111, 66-78.
- Malmgren, A., Tao, L. & Wennström, M. 2000. Konvertering av befintliga oljepannor till pulvereldning för spetslast. *Värmeforsk Stockholm*, rapport 686.
- Martinsson, L. 2003. Råvaror för framtida tillverkning av bränslepellets i Sverige. *Värmeforsk Stockholm*, rapport 813.
- Mattsson, J.E. & Kofman, P. 2003. Influence of particle size and moisture content on tendency to bridge in biofuels made from willow shoots. *Biomass and Bioenergy* 24, 429-435.
- Mattsson, J.E. & Kofman, P. 2002. Method and apparatus for measuring the tendency of solid biofuels to bridge over openings. *Biomass and Bioenergy* 22, 179-185.
- Mattsson J.E. Tendency to bridge over opening for chopped Phalaris and straw of Triticum mixed in different proportions with wood chips. 1990. *Biomass and Bioenergy* 12(3), 199-210.
- Miles, T., Miles Jr, T., Baxter, L., Bryers, R., Jenkins, B. & Oden, L. 1996. Boiler deposits from firing biomass fuels. *Biomass and Bioenergy* 10(2-3), 125-138.
- Morey, G. W., Kracek, F. C. & Bowen, N.L. 1930. The ternary system K<sub>2</sub>O-CaO-SiO<sub>2</sub>. *Journal of the society of glass technology*, 149-187.
- Muzio, L.J., Quatucy, G.C. & Cichanowicz, J.E. 2002. Overview and status of post-combustion NO<sub>x</sub> control: SNCR, SCR and hybrid technologies. *Int. J. Environ. Pollut* 17, 4-30.
- Naito, M., Hayakawa, O., Nakahira, K., Mori, H. & Tsubaki, J. 1998. Effect of particle shape on the particle size distribution measured with commercial equipment. *Powder Technology* 100, 52-60.
- Natarajan, E., Öhman, M., Gabra, M., Nordin, A., Liliedahl, T. & Rao, A.N. 1998. Experimental determination of bed agglomeration tendencies of some common agricultural residues in fluidized bed combustion and gasification. *Biomass and Bioenergy* 15(2), 163-169.

- Nordin, A. 1993. On the chemistry of combustion and gasification of biomass fuels, peat and waste; environmental aspects. *Doctorial thesis. University of Umeå, Department of Inorganic Chemistry, Sweden.*
- Obernberger, I., Biedermann, F., Widmann, W. & Riedl, R. 1997. Concentrations of inorganic elements in biomass fuels and recovery in the different ash fractions. *Biomass and Bioenergy 12*(3), 211-224.
- Obernberger, I. 1998. Decentralized biomass combustion: state of the art and future development. *Biomass and Bioenergy 14*, 33-56.
- Obernberger, I. & Thek, G. 2002. Physical characterisation and chemical composition of densified biomass fuels with regard to their combustion behaviour. *Proceedings of the first world conference on pellets*, Stockholm, 2-4 September 2002.
- Olanders, B. & Gunnars, N.E. 1994. Some aspects of the formation of nitric oxide during the combustion of biomass fuels in a laboratory furnace. *Biomass and Bioenergy 6*(6), 443-451.
- Olsson, M. 2001. Träpellets som småskaligt biobränsle. *Avdelningen för kemisk miljövetenskap, Chalmers Tekniska Högskola, Göteborg. Working report.*
- Olsson, M. 2002. Wood pellets as low-emitting residential biofuel. *Thesis of Licentiate, Chalmers University of Technology, Göteborg, 2002.*
- Pharmavision 830. Automated particle size and shape measurement. *Malvern Instruments, Malvern, UK, www.malvern.co.uk*
- Pettersson, M. 1999. Briquetting of biomass: A compilation of techniques and machinery. *Sveriges Lantbruksuniversitet, institutionen för skogsteknologi. Students reports no. 22, Umeå.*
- Radojevic, M. 1998. Reduction of nitrogen oxides in flue gases. *Environ. Pollut 102*, 685-689.
- Rawle, A. 2001. The basic principles of particle size analysis. *Malvern Instruments, Malvern, UK, <http://www.malvern.se/laboratory/psintro.htm> (2001).*
- Reuther, J.J., Karsner, G.G. & Jack, S.T. 1982. Plane Flame Furnace Combustion Studies of Pulverized Wood. *Fundamentals of Thermchemical Biomass Conversion*, Estes Park, Colorado, 1982.
- Rietz, E. 2002. Pellets production in Sweden. *Abstract of the first world conference on pellets*, Stockholm, 2-4 September 2002
- Rydehell, M. & Löfgren, B.E. 2001. Bioenergi-vår nästa tillväxtbransch. *Åfab, Lidköping 19 september 2001.*
- Ryk, L. 1995. Jämförelse mellan olika metoder att karakterisera partikelegenskaper hos bränslepulver av trä, torv, olivkärnor och kol. *Värmeforsk Stockholm*, rapport 530.
- Salzmann, R. & Nussbaumer, T. 2001. Fuel Staging for NO<sub>x</sub> Reduction in Biomass Combustion: Experiments and Modeling. *Energy & Fuels, 15*, 575-582.
- Samuelsson, R., Burvall, J. & Igsell, P. Report on Round Robin Analysis of Peat and Biofuels. *Swedish University of Agricultural Sciences, Department of Agricultural Research for Northern Sweden, Umeå. Working report.*
- Sander, B. Properties of Danish biofuels and the requirements for powder production. *Biomass and Bioenergy 12*, 177-183.
- Scanlon, M.G. & Lamb, J. 1995. Fracture mechanisms and particle shape formation during size reduction of a model food material. *Journal of materials science 30*, 2577-2583.
- Skrifvars, B.J., Backman, R., Hupa, M. 1998. Characterization of the sintering tendency of ten biomass ashes in FBC conditions by a laboratory test and by phase equilibrium calculations. *Fuel Processing Technology 56*, 55-67.
- Skrifvars, B. J., Öhman, M., Nordin, A. & Hupa, M. 1999. Predicting bed agglomeration tendencies for biomass fuels fired in FBC boilers: a comparison of three different prediction methods. *Energy & Fuels 13*, 359-363.
- SS 18 71 71:1. 1984. Solids-Determination of ash content. Swedish Standards Institution. Stockholm: SIS.
- SS 18 71 54:1. 1984. Solid mineral fuels-Determination of chlorine using Eschka mixture. Swedish Standards Institution. Stockholm: SIS.
- SS 18 71 70:2. 1990. Solids and peat-Determination of total moisture content. Swedish Standards Institution. Stockholm: SIS.

- SS ISO 562. 1990. Hard coal and coke-Determination of volatile matter content. Swedish Standards Institution. Stockholm:SIS.
- SS 18 71 75:1. 1990. Peat-determination of mechanical strength of sod peat. Swedish Standards Institution. Stockholm:SIS.
- SS 18 71 74:1. 1990. Biofuels and peat-determination of size distribution. Swedish Standards Institution. Stockholm:SIS.
- SS 18 71 77:1. 1991. Solids-Determination of total sulfur using a high temperature tube furnace combustion method. Swedish Standards Institution. Stockholm:SIS.
- SS 18 71 87:1. 1995. Solid fuels-determination of the amount of unburned material in solid residues from combustion. Swedish Standards Institution. Stockholm:SIS.
- SS ISO 1928:1. 1996. Solid mineral fuels-Determination of gross calorific value by the bomb calorimetric method, and calculation of net calorific value. Swedish Standards Institution. Stockholm:SIS.
- SS 18 71 23. 1998. Biobränslen och torv-Bränslebriketter-Klassificering. (Biofuels and peat-Fuel briquettes-Classification) Swedish Standards Institution. Stockholm:SIS.
- SS 18 71 20. 1998. Biobränslen och torv-Bränslepelleter-Klassificering. (Biofuels and peat-Fuel pellets-Classification). Swedish Standards Institution. Stockholm:SIS.
- Ståhl, M., Granström, K., Berghel, J. & Renström, R. 2002. Industrial processes for biomass drying and their effects on the quality properties of wood pellets. *Proceedings of the first world conference on pellets*, Stockholm, 2-4 September 2002.
- Swedish Energy Agency. 2002. Energy in Sweden 2002. ET 20:2002. Eskilstuna.
- Svenska Träbränsleförbundet. 2002. Sammanställning av produktion och utleveranser av träbränsle 2001, GWh. Stockholm.
- Van der Lans, R.P. 1997. Influence of process parameters on nitrogen oxide formation in pulverized coal burners. *Prog. Energy Combustion Sciences* 23, 349-377.
- Vinterbäck, J. 2000. Wood Pellet Use in Sweden. *Doctoral thesis. Swedish University of Agricultural Sciences, Uppsala*, 2000.
- Werther, J, Saenger, M, Hartge, E.U, Ogada, T & Siagi, Z. 2000. Combustion of agricultural residues. *Progress in Energy and Combustion Science* 26, 1-27.
- Wiklund, S.E, Leven, P, Eriksson, L & Lundin, T. 1998. Malningsteknik för biopulver. *Värmeforsk Stockholm*, rapport 650.
- Winter, F, Wartha, H & Hofbauer. 1999. NO and N<sub>2</sub>O formation during the combustion of wood, straw, malt waste and peat. *Bioresource Technology* 70, 39-49.
- WWW.akerbransle.com, 16-nov-2003.
- WWW.btk.slu.se/eng/avdelningar/btc/default.cfm
- Xu, R, Andreina, O & Guida, D. 2003. Comparison of sizing small particles using different technologies. *Powder Technology* 132, 145-153.
- Zevenhoven-Onderwater, M, Backman, R, Skrifvars, BJ & Hupa, M. 2001. The ash chemistry in fluidized bed gasification of biomass fuels. Part I: predicting the chemistry of melting ashes and ash-bed material interaction. *Fuel* 80, 1489-1502.
- Zevenhoven-Onderwater, M. 2003. Ash forming matter in biomass fuels. *Åbo Akademi, Finland, Academic dissertation*, report 01-03.
- Öhman, M. & Nordin, A. 1995. Formation and reduction of nitrogen oxide in a pilot scale fluidized bed biomass combustor. *Proceedings of the 8<sup>th</sup> European conference on Biomass for Energy, Environment, Agriculture and Industry*. Vienna 3-5 October, pp 821-830.
- Öhman, M. & Nordin, A. 1998. A new method for quantification of fluidized bed agglomeration tendencies: a sensitivity analysis. *Energy & Fuels* 12, 90-94.
- Öhman, M, Nordin, A, Skrifvars, BJ & Backman, R. 2000. Bed agglomeration characteristics during fluidized bed combustion of biomass fuels. *Energy & Fuels* 14, 227-233.
- Öhman, M., Boman, C, Hedman, H, Nordin, A, Boström, D. 2002. Slagging tendencies of wood pellet ash during combustion in residential pellet burners. *Proceedings of the first world conference on pellets*, Stockholm, 2-4 September 2002.