

# Triplex Reel Mower

---

## Owner/Operator Manual



## Model

99500500 – 8400



ENGLISH

03296500 4/08  
Printed in USA

# TABLE OF CONTENTS

SAFETY .....	3	STORAGE .....	26
OPERATION .....	8	TROUBLESHOOTING .....	27
ASSEMBLY .....	13	SPECIFICATIONS .....	28
SERVICE AND ADJUSTMENTS .....	16	WARRANTY .....	29
MAINTENANCE .....	21		

## INTRODUCTION

### NON-ENGLISH MANUALS



Manuals in languages other than English may be obtained from your Dealer. Visit your dealer or [www.ariens.com](http://www.ariens.com) for a list of languages available for your equipment.

Manuals printed in languages other than English are also available as a free download on our website:

<http://www.ariens.com>

### MANUALES EN IDIOMAS DIFERENTES DEL INGLÉS



Puede obtener manuales en idiomas diferentes del inglés en su distribuidor. Visite a su distribuidor o vaya a [www.ariens.com](http://www.ariens.com) para obtener una lista de idiomas disponibles para su equipo.

También puede imprimir manuales en idiomas diferentes del inglés descargándolos gratuitamente de nuestra página Web:

<http://www.ariens.com>

### MANUELS NON ANGLAIS



Des manuels dans différentes langues sont disponibles chez votre revendeur. Rendez-vous chez votre revendeur ou allez sur le site [www.ariens.com](http://www.ariens.com) pour consulter la liste des langues disponibles pour votre équipement.

Les manuels imprimés dans des langues différentes de l'anglais sont également disponibles en téléchargement gratuit sur notre site Web:

<http://www.ariens.com>

### THE MANUAL

This manual has been prepared by National Mower as an aid to users for set up, operation, and servicing parts. Additional information will gladly be furnished by calling or writing the company.

Please furnish us with the Model number, Serial number, and date of purchase when contacting us about your machine.

Designations of right, left, front, and rear are used in the position of the operator sitting in the seat.

Metric equivalents are provided wherever possible for users outside of the United States.

Carefully inspect your machine and crates for damage that could have occurred during shipment. If damages or shortages are noted, have the transportation company's representative note this on the bill of lading.

**IMPORTANT:** Claims for shipping damages must be noted by the consignee at the point of designation and filed with the transportation company.

### SERVICE AND REPLACEMENT PARTS

When ordering replacement parts or making service inquiries, know the Model and Serial numbers of your unit and engine.

Numbers are located on the product registration form in the unit literature package. They are also printed on a serial number label, located on the frame of your unit.

## PRODUCT REGISTRATION

The National Mower dealer must register the product at the time of purchase. Registering the product will help the company process warranty claims or contact you with the latest service information. All claims meeting requirements during the limited warranty period will be honored, whether or not the product registration card is returned. Keep a proof of purchase if you do not register your unit.

**Customer Note:** If the Dealer does not register your product, please fill out, sign and return the product registration card to National Mower or go to [www.nationalmower.com](http://www.nationalmower.com) on the internet.

## UNAUTHORIZED REPLACEMENT PARTS

Use only National Mower replacement parts. Replacing any part on this vehicle with anything other than a National Mower authorized replacement part may adversely affect the performance, durability, or safety of this unit and may void the warranty. National Mower disclaims liability for any claims or damages, whether warranty, property damage, personal injury or death arising out of the use of unauthorized replacement parts. To locate your nearest National Mower Dealer, go to [www.nationalmower.com](http://www.nationalmower.com) on the internet.

## DEALER DELIVERY

Dealer should:

1. Check that all assembly and adjustments have been properly completed.
2. Fill out Original Purchaser Registration Card and return the card to National Mower.
3. Explain Turf Products Limited Warranty Policy.
4. Explain recommended lubrication and maintenance. Advise customer on adjustments.
5. Instruct customer on controls and operation of unit. Discuss and emphasize the Safety Rules. Advise customer to thoroughly read and understand all operating manuals supplied with the unit.

## DISCLAIMER

reserves the right to discontinue, make changes to, and add improvements upon its products at any time without public notice or obligation. The descriptions and specifications contained in this manual were in effect at printing. Equipment described within this manual may be optional. Some illustrations may not apply to your unit.

# SAFETY



**WARNING:** This cutting machine is capable of amputating hands and feet and throwing objects. Failure to observe the safety instructions in the manuals and on decals could result in serious injury or death. Slopes are a major factor related to loss-of-control and tip-over accidents. Operation on all slopes requires extra caution. Tragic accidents can occur if the operator is not alert to the presence of children. Never assume that children will remain where you last saw them. Gasoline is extremely flammable and the vapors are explosive, handle with care. Disengage attachment, stop unit and engine, remove key, engage parking brake, and allow moving parts to stop before leaving operator's position.



OL1253



OL3900

## SAFETY ALERT SYMBOL

These are safety alert symbols. They mean:

- ATTENTION!**
- YOUR SAFETY IS INVOLVED!**
- When you see this symbol:
- BECOME ALERT!**
- OBEY THE MESSAGE!**

## SIGNAL WORDS

The safety alert symbols above and signal words below are used on decals and in this manual.

Read and understand all safety messages.



**DANGER: IMMINENTLY HAZARDOUS SITUATION!** If not avoided, WILL RESULT in death or serious injury.



**WARNING: POTENTIALLY HAZARDOUS SITUATION!** If not avoided, COULD RESULT in death or serious injury.



**CAUTION: POTENTIALLY HAZARDOUS SITUATION!** If not avoided, MAY RESULT in minor or moderate injury. It may also be used to alert against unsafe practices.

## NOTATIONS

**NOTE:** General reference information for proper operation and maintenance practices.

**NOTE:** Specific procedures or information required to prevent damage to unit or attachment.

## PRACTICES AND LAWS

Practice usual and customary safe working precautions, for the benefit of yourself and others. Understand and follow all safety messages. Be alert to unsafe conditions and the possibility of minor, moderate, or serious injury or death. Learn applicable rules and laws in your area, including those that may restrict the age of the operator.

## REQUIRED OPERATOR TRAINING

Original purchaser of this unit was instructed by the seller on safe and proper operation. If unit is to be used by someone other than original purchaser (loaned, rented or sold), ALWAYS provide this manual and any needed safety training before operation.

## Emission Control System Certification Label

**NOTE:** Tampering with emission control and components by unauthorized personnel may result in severe fines or penalties. Emission controls and components can only be adjusted by EPA and/or CARB authorized service centers. Contact your National Mower retailer concerning emission controls and component questions.

## SAFETY DECALS

National Mower has provided decals in many locations throughout the machine to aid the operator in identifying, controlling and operating the 8400 safely and correctly. It is important that all decals are clean and visible at all times. Replace decals that are damaged, missing or accidentally painted over.

### 1. DANGER! KEEP HANDS AND FEET AWAY



### 2. CAUTION!



Read Owner/Operator Manual before servicing machine.



Reduce ground speed when operating unit down hill.



Keep people away from unit while operating.

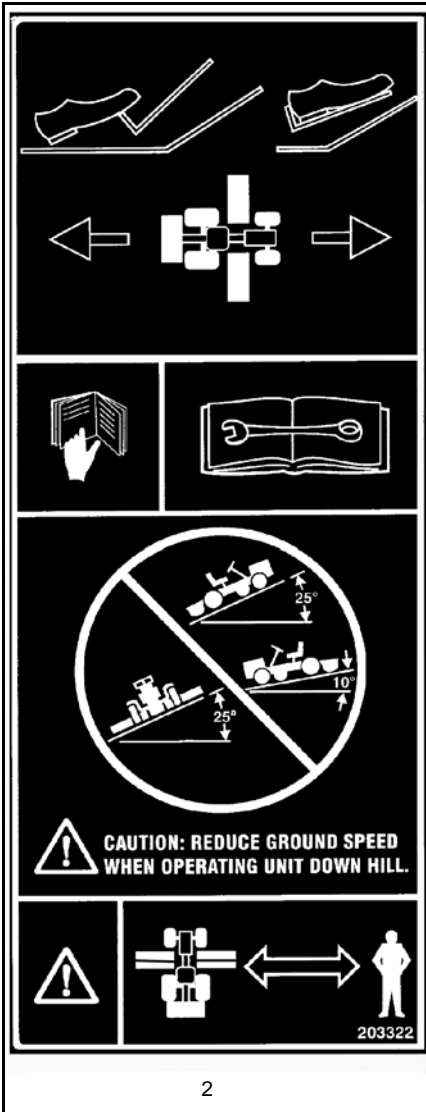

2

## SAFETY RULES

Read, understand, and follow all safety practices in Owner/Operator Manual before beginning assembly. Failure to follow instructions could result in personal injury and/or damage to unit.

Complete a walk around inspection of unit and work area to understand:

- Work area
- Your unit
- All safety decals

Determine which attachments are needed and can be used safely.

Inspect unit before each use for: missing or damaged decals and shields, correctly operating safety interlock system, and deterioration of grass catchers. Replace or repair as needed.

ALWAYS check overhead and side clearances carefully before operation. ALWAYS be aware of traffic when operating along streets or curbs.

Keep children and people away.

Keep children out of work area and under watchful care of a responsible adult.

Keep area of operation clear of all toys, pets, and debris. Thrown objects can cause injury.

Check for weak spots on docks, ramps or floors. Avoid uneven work areas and rough terrain. Stay alert for hidden hazards or traffic.

DO NOT operate near drop-offs, ditches, or embankments. Unit can suddenly turn over if a wheel is over the edge of a cliff or ditch, or if an edge caves in.

Data indicates that operators, age 60 and above, are involved in a larger percentage of riding mower related injuries. These operators should evaluate their ability to operate the riding mower safely enough to protect themselves and others from serious injury.

Read the entire Owner/Operator manual and other training material. If the operator or the mechanic cannot read the manual, it is the owner's responsibility to explain it to them. Only the user can prevent and is responsible for accidents or injuries occurring to themselves, other people or property.

Only trained adults may operate or service unit. Training includes actual operation.

Local regulations may restrict the age of the operator.

NEVER allow children to operate or play on or near unit. Be alert and shut off unit if children enter area.

NEVER operate unit after or during the use of medication, drugs or alcohol. Safe operation requires your complete and unimpaired attention at all times.

DO NOT wear loose clothing or jewelry and tie back hair that may get caught in rotating parts.

Wear adequate outer garments.

NEVER wear open sandals or canvas shoes during operation. Wear adequate safety gear, protective gloves and footwear.

Wear proper footwear to improve footing on slippery surfaces.

Always wear safety goggles or safety glasses with side shields when operating mower.

Moving parts can cut or amputate fingers or a hand. Wrap blade(s) or wear gloves to service. On multiblade mowers, rotation of one blade will cause all blades to rotate.

NEVER place your hands or any part of your body or clothing inside or near any moving part while unit is running.

ALWAYS keep hands and feet away from all rotating parts during operation. Rotating parts can cut off body parts.

ALWAYS keep body and hands away from pin holes or nozzles which eject hydraulic fluid under pressure.

DO NOT touch parts which are hot. Allow parts to cool.

ALWAYS keep hands and feet away from all pinch points.

Read, understand, and follow all instructions in the manual and on the machine before starting.

Understand:

How to operate all controls

The functions of all controls

How to STOP in an Emergency

Braking and steering characteristics

Turning radius and clearances

Keep safety devices or guards in place and functioning properly. NEVER modify or remove safety devices.

Do not operate without either entire grass catcher or the discharge guard in place.

Stop engine before removing grass catcher or unclogging chute.

Ensure Safety Interlock System is functioning properly. DO NOT operate unit if safety interlock is damaged or disabled.

Use care when approaching blind corners, shrubs, trees or other objects that may obscure vision.

Dust, smoke, fog, etc. can reduce vision and cause an accident. Mow only in daylight or good artificial light.

Avoid slippery surfaces. Always be sure of your footing.

DO NOT mow on wet grass. Reduced traction could cause sliding and effect the machine's stability.

Watch for traffic when operating near or crossing roadways.

Never carry passengers.

DO NOT try to stabilize the machine by putting your foot on the ground.

Never direct discharge towards persons or property that may be injured or damaged by thrown objects. Use extreme caution on gravel surfaces.

Always stand clear of the discharge area.

ALWAYS disengage PTO, stop unit and engine, remove key, engage parking brake and allow moving parts to stop before leaving operator's position.

Never engage PTO while raising attachment or when attachment is in raised position.

DO NOT operate at too fast a rate. DO NOT change engine governor settings or over-speed engine. Slow down before turning.

DO NOT operate in reverse unless absolutely necessary. ALWAYS look down and behind before and while backing.

Stop and inspect equipment if you strike an object or if there is an unusual vibration.

Repair, if necessary, before restarting. Never make adjustments or repairs with the engine running.

Mower blades are sharp and can cut you. Wrap the blade(s) or wear gloves, and use extra caution when servicing them. NEVER weld or straighten mower blades.

Rotation of one blade may cause rotation of the other blades.

Take all possible precautions when leaving unit unattended. Shut off engine. Remove wire from spark plug and secure it away from spark plug.

ALWAYS remove key to prevent unauthorized use.

Know the weight of loads. Limit loads to those you can safely control and the unit can safely handle.

Disengage PTO when attachment is not in use. ALWAYS turn off power to attachment when travelling, crossing driveways, etc.

Mow up and down slopes, not across them.

Keep all movements on the slope *slow* and *gradual*. Do not make sudden changes in speed or direction.

Avoid starting or stopping on the slope. If tires lose traction, disengage the blades and proceed slowly *straight* down the slope.

If you cannot back up a slope or you feel uneasy on it, do not mow it.

DO NOT park on slopes unless necessary. When parking on slope always chock or block wheels. Always set parking brake.

Use a slow speed. Tires may lose traction on slopes even though the brakes are functioning properly.

Do not bypass transmission when on a slope.

Tow only with a machine that has a hitch designed for towing. Do not attach towed equipment except at the hitch point.

Follow the manufacturer's recommendations for weight limits for towed equipment and towing on slopes.

NEVER allow children or others in or on towed equipment.

On slopes, the weight of the towed equipment may cause loss of control.

Travel slowly and allow extra distance to stop.

Use extra care when loading or unloading unit onto trailer or truck.

Secure unit chassis to transport vehicle.

NEVER secure from rods or linkages that could be damaged.

DO NOT transport machine while engine is running.

ALWAYS turn off power to attachment and shut off fuel when transporting unit.

Keep unit free of debris. Clean up oil or fuel spills.

ALWAYS block wheels and know all jack stands are strong and secure and will hold weight of unit during maintenance.

Release pressure slowly from components with stored energy.

NEVER attempt to make any adjustments to unit while engine is running (except where specifically recommended). Stop engine, remove key or spark plug wire and wait for all moving parts to stop before servicing or cleaning.

Check parking brake operation frequently. Adjust and service as required.

ALWAYS maintain unit in safe operating condition.

Maintain or replace safety and instruction labels, as necessary.

Lower cutting deck unless a positive mechanical lock is used.

Use only attachments or accessories designed for your unit.

Check all hardware at regular intervals, especially blade attachment bolts. Keep all hardware properly tightened.

Check attachment components frequently. If worn or damaged, replace with manufacturer's recommended parts.

# OPERATION

## CONTROLS AND FEATURES

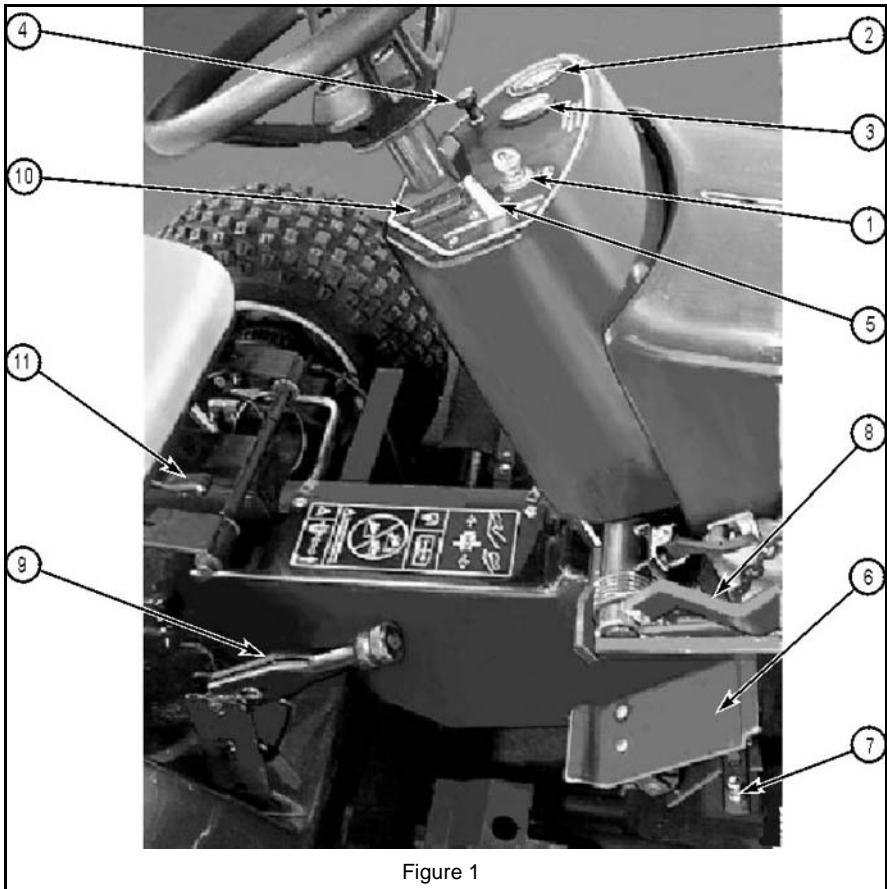

Figure 1

### Ignition Switch

Insert key in switch (1, Figure 1) and turn clockwise as far as it will go to start engine, then release. The reel control switch must be in the off position and the traction control pedal in the neutral position before starting engine.

Do not hold key in "on" position more than 30 seconds at a time.

Key should be removed when tractor is not in use to prevent unauthorized operation.

See *STARTING THE ENGINE* on page 11 for complete starting information.

### Hour Meter

The hour meter (2, Figure 1) indicates the number of hours the tractor has been operated. It can be used to keep track of maintenance intervals and the amount of time required to perform various tasks. The hour meter operates whenever the ignition key is in the "on" position.

### Amp Meter

The amp meter (3, Figure 1) indicates the condition of the charging circuit. It should indicate a positive charge during normal mowing. If the amp meter indicates a negative reading, refer to the Briggs and Stratton engine manual.



## Choke

When starting a cold engine, pull the choke control (4, Figure 1) out to close the choke plate and allow a richer fuel mixture to enter the engine. After the engine starts, push the choke control about halfway in to keep the choke plate partially closed. Push the choke control all the way in to open the choke plate for normal operation after the engine is properly warmed. A warm engine usually requires less choke to start.

## Throttle Lever

Push throttle lever (5, Figure 1) forward to increase engine speed; pull back to decrease the engine speed.

Position throttle at full throttle or slightly less for optimum power and reel speed during mowing.

## Traction Pedal

The traction pedal (6, Figure 1) operates the forward and reverse direction and speed of the tractor.

Moving forward: push the forward or toe of the pedal down with the ball of your foot to increase the forward speed.

Moving backward: push the heel of the pedal down with the heel of your foot to increase the reverse speed.

When the traction pedal is released, the machine will slow down and stop. The traction pedal must be in neutral position before mower will start.

## Speed Control

The speed control (7, Figure 1) is meant to ease operator fatigue by holding the forward speed to a constant that is best suited for the present mowing conditions.

Adjust the hex head bolt up or down and lock it with the lock nut to limit the pedal travel.

Swing the speed control away from the traction pedal to again allow a full range of forward speeds.

## Wing Mower Lift

Positioning the wing mower lift lever (8, Figure 1) will lower the side mowing units to the ground.

Pulling lever back and over center holds the mowers off the ground. Always keep mowers up when not mowing or transporting. Keep mower down during storage.



**CAUTION:** Do not stand on mowers when in lifted position.

## Parking Brake

A convenient parking brake (9, Figure 1) is located just below the right side of the operator's seat.

Pulling back and over center will engage the parking brake, and moving it forward, as shown, will release it.

**IMPORTANT:** Always make sure brake is released before moving forward, and ensure that the brake is engaged when leaving the mower. Never try to stop the forward motion of the unit with the parking brake.

## Reel Drive Control

By toggling the reel drive control switch **ON** (10, Figure 1), an electric clutch is activated which engages power to the reels.

Pushing the switch to the **OFF** position disengages the clutch. This control must be in the **OFF** position before mower will start.

## Seat Position Lever

The position of the seat is adjusted forward or backward by actuating the seat lever (11, Figure 1).

Releasing the lever will lock the seat at its present position.

## Rear Mower Lift Lever

Move the rear mower lift lever (1, Figure 2) up and forward over center; the rear mower will be held off the ground.

Pull the lever up and back; the rear mower is lowered for operation or storage.

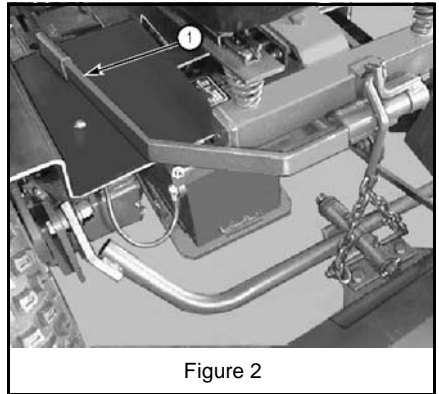

Figure 2

## Free-Wheeling Valve

To permit moving the machine without starting the engine, a free-wheeling device or tow valve has been provided. The lever (1, Figure 3) is located between the engine and hydraulic pump.

To open the valve to permit free-wheeling, simply lift up on the rod and latch washer face (2, Figure 3) onto the bracket slot.

Reverse the procedure for normal operation of the machine.

**NOTE:** Valve must be closed to operate machine.

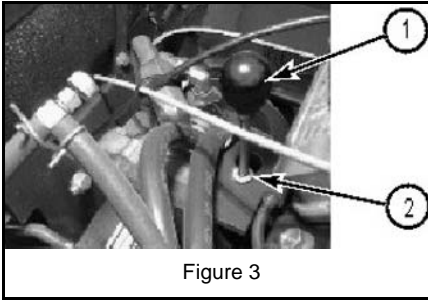

Figure 3

### Interlock Switches

There are three safety switches on your 8400. They are a safety precaution which will allow you to start your mower only when the traction pedal is in neutral, the reel control switch is in the disengaged position, and the operator is seated on the tractor. If you are able to start your mower with the pedal or switch in any other position, adjustment of the switched is required.

### Traction Drive Train

Power from the engine is transmitted by belt to the variable displacement pump. The pump supplies hydraulic fluid to the hydraulic motors.

### Reel Drive

Power to the reels is transmitted from the engine to a countershaft shaft, which is controlled by an electric clutch switched on and off at the dash.

## PRIOR TO STARTING THE UNIT

1. Fill the gas tank with good quality, clean, regular unleaded gasoline, 85 octane minimum. **DO NOT** use hi-test gasoline or an oil/gasoline mixture. Fill tank to 1 inch (25 mm) below filler neck. Do not overfill.
2. Check oil in the engine crankcase. It should be filled to the full mark on the dipstick. See Lubrication Specifications in this manual for recommend oil viscosity.
3. Check all lubrication points outlined in "LUBRICATION on page 23."
4. Check tires for proper inflation. See Mower Specifications in this manual.

5. Check oil level in hydraulic reservoir. Oil level should be the level shown on the decal on the side of the oil tank when unit is sitting on a level surface.
6. Check reels for desired cutting height. To provide a satisfactory cut, it is essential for all reels to be accurately adjusted to exactly the same height. See *HEIGHT OF CUT ADJUSTMENT* on page 18.

**NOTE:** If adjustments are necessary, see *SERVICE AND ADJUSTMENTS* on page 16 for instructions.

## OPERATING SUGGESTIONS

### Engine

Your machine is powered by a twin cylinder, 4 cycle Briggs and Stratton Vanguard engine which uses unleaded gasoline, 85 octane minimum. **DO NOT MIX OIL WITH GASOLINE!** Engine speed is controlled by means of a throttle lever mounted on the dash panel.

A separate Engine Manual, prepared by the engine manufacturer, is supplied. Study the manual carefully until you are familiar with the maintenance, operation, adjustment and repair of your equipment. Proper attention to the engine manufacturer's directions will assure maximum service life of the engine and highest operating efficiency.



**CAUTION:** Under no circumstances should the engine be started with the operator or bystander standing next to tractor or cutting units.

1. When starting the engine, the operator must be seated on the seat, reel control switch must be off, and traction pedal must be in neutral (the center position).
2. The operator should practice mowing in an open clear area to become thoroughly familiar with the operation of the tractor.
3. Never operate the mowers when they are not cutting grass, as excessive friction and heat will develop between the bedknife and reel, damaging the cutting edge.
4. Plan your cutting pattern to avoid any unnecessary stops or sharp, frequent turns. Study the area to determine the best mowing procedure. Consider the height of the grass and the type of terrain (level, hilly, or rough). Each condition will require certain adjustments or precautions.

- Before leaving the mower, always lower wing mowers so that when exiting the mower and stepping on the non-skid pads of the wing mowers, it will not put excessive strain on the lift mechanism.
- Operate at speeds which allow you to have complete control of the tractor and allow you to stop the tractor or maneuver safely in case of an emergency. It is recommended that you adjust the Speed Control (7, Figure 1) to maintain a constant pedal position/speed and reduce the operator fatigue.
- To obtain maximum mower life, the operator must use discretion when mowing near gravel areas (roadway, parking areas, cart paths etc.). By operating too close to overlapping gravel areas, stones maybe picked up by the mower and forced between bedknife and reel, causing wear and serious damage to the cutting unit.

## STARTING THE ENGINE

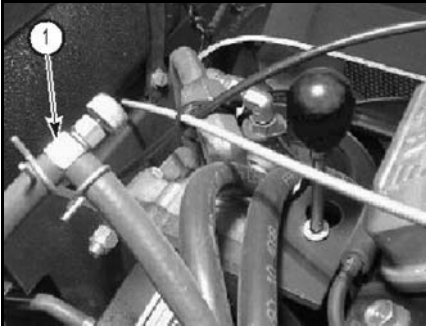

Figure 4

- Open the fuel tank shut off valve (1, Figure 4) (located by the fuel tank) on the fuel line by turning knob counterclockwise.
- Sit in operator's seat.
- Place reel control switch in the "Off" position.
- Place the traction pedal in "Neutral" position.
- Pull choke control out and move throttle control lever to mid position.
- Engage parking brake.
- Insert ignition key, turn clockwise to "start" position, and release key when engine starts. Do not hold key in "start" position for more than 30 seconds or damage to the starter may result. If engine does not start within this time, release the key and wait for a few minutes before trying again.

- Push choke control in as engine warms up (or immediately if engine is warm).

## DRIVING THE TRACTOR

- Position throttle at full throttle or slightly less for optimum power and reel speed.
- Release parking brake (9, Figure 1).
- Moving forward: Push the toe of the traction pedal forward with the ball of your foot to increase the forward speed.
- Moving backward: Push the heel of the traction pedal in with the heel of your foot to increase the reverse speed.
- To return traction pedal to neutral, rock pedal with foot until pedal stops. The pedal will stay in neutral when you remove your foot.



**DANGER:** To avoid possible loss of control and/or serious bodily injury, avoid abrupt changes in the traction pedal position. Reduce speed on slopes, rough terrain, and in sharp turns to prevent tipping or loss of control.

## MOWING OPERATION

- Check the turf area for debris that would cause damage to the reels. Never operate the mowers when they are not cutting grass, as excessive friction and heat will develop between the bedknife and reel, which will damage the cutting edge.
- When cutting large areas, the most satisfactory method is to first cut the outer area and then mow clockwise toward the center. The next time you cut, it is advised that you mow in the opposite direction to prevent grass matting.
- Cutting speeds are governed by conditions of turf, type of terrain, and obstacles to be encountered. Operate tractor at slow speeds when turning.

## MOWING

1. Stop tractor by releasing the traction pedal (8, Figure 1), then slowly lower the mower units.



**CAUTION:** Dropping cutting units abruptly could damage them or the H-frame of the wing mowers.

2. Engage reel control switch (10, Figure 1) to the "On" position.
3. Depress traction pedal to the desired speed (see *Traction Pedal* on page 9 and *Speed Control* on page 9). Reel speed is constant and ground speed is variable with the traction pedal. Do not try to regulate ground speed with engine throttle (see *Throttle Lever* on page 9).

## VERTICAL MOWING UNIT

1. Be aware that the blades can extend below the roller. Use care when lowering cutting units down onto a hard surface to avoid bending the blades.
2. Setting the depth of cut: Always start with shallow, less aggressive cuts. Set the blades to zero (blade tips even with bottom of roller). Gradually increase depth of cut until suitable results are obtained (see *HEIGHT OF CUT ADJUSTMENT* on page 18).
3. Keep in mind that vertical mowing is similar to cutting grass; you can be too aggressive. When vertical mowing grass that has never been vertical mowed, avoid going too deep to start with. Gradually increase the depth of cut to obtain desired results.



**CAUTION:** Dropping the vertical cutting units abruptly could damage the blades and/or the H-frame of the wing mowers.

## HILLSIDE OPERATION

The 8400 has been designed for good traction and stability under normal mowing conditions. However, caution must still be used during slope operation, especially when the grass is wet.

Wet grass limits traction and steering control.

In order to minimize the possibility of tipping, the least dangerous method of operating on hills and terraces is to travel horizontally to the hill. It is also advisable to avoid any unnecessary turns while operating on hills. Use extreme caution and travel at reduced speeds.

1. When operating on hillsides or slopes, maintain full engine speed, but let up on the traction pedal as power requirements increase. This will maintain the performance necessary.
2. It is best to mow along the side of the hill, starting at the bottom and working upwards. This allows the machine to negotiate the slope without mowing in a downhill direction.
3. It is essential for the correct tire pressure to be established for maximum traction and hillside holding.

## PUSHING OR TOWING INSTRUCTIONS

The 8400 has a free-wheeling valve, or "tow valve," which will permit moving the machine at slow speeds without starting the engine.

Do not exceed 2 mph (3 km/h) while pushing or towing (see *Free-Wheeling Valve* on page 9).

## AFTER OPERATION

1. Clean the entire mower after use. Remove loose grass clippings and caked grass to prevent clogging the vented lubrication points and corroding parts.
2. The engine is air cooled. Do not permit dirt or grass clippings to accumulate on the air intake screen, cylinder heads, or on hydraulic pump cooling fan to prevent serious heat damage to the engine or hydraulic pump.
3. If fan blades become damaged, replace the fan.

# ASSEMBLY

## TRACTOR



**CAUTION:** Handle banding material with caution. Use heavy leather gloves. Banding is sharp!

1. Remove crating top, front, and sides.
2. Cut banding from around tractor, tires, and armrest box.
3. Separate steering wheel from tire.
4. Remove rear mower belt shield from manual lift handle.



**CAUTION:** Use jack stands under tractor whenever elevated off the tires.

Lift tractor up off axle crate supports to sufficiently assemble tire and wheels to the tractor.

Lower tractor down onto crate. Tractor may now be driven or rolled off the crate. To allow the tractor to roll freely without engaging the engine or drive, a tow valve is provided. It is located under the hood directly behind the engine (see Figure 3).

## REAR MOWER

1. Remove rear mower from crate and position behind tractor as shown in Figure 5.
2. Pivot rear mower lifter handle (1, Figure 5) up and back to lower rear mower pull plate on the pull yoke. Position mounting flange (2, Figure 6) on the center front of the rear mower frame under the pull plate (3, Figure 6) and fasten securely with two fasteners already installed in pull plate.
3. Install V-belt (4, Figure 5) onto double groove pulley (5, Figure 5) located on the right rear side of the frame. Raise rear mower belt idler (6, Figure 5), and run V-belt under idler pulley as shown.
4. Position rear mower clutch guard (7, Figure 5) over rear mower shaft and pulley area, and fasten right side to support (8, Figure 5) with a 1/4"-20 x 1/2" round-head slotted screw. Secure rear flange of guard with (2) 1/4"-20 x 1/2" hex head cap screws, lock washers, and nuts.

## Check Tire Pressure



**CAUTION:** Avoid injury! Explosive separation of tire and rim parts is possible when they are serviced incorrectly:

- Do not attempt to mount a tire without the proper equipment and experience to perform the job.
- Do not inflate the tires above the recommended pressure.
- Do not weld or heat a wheel and tire assembly. Heat can cause an increase in air pressure resulting in an explosion. Welding can structurally weaken or deform the wheel.
- Do not stand in front or over the tire assembly when inflating. Use a clip-on chuck and extension hose long enough to allow you to stand to one side.

## SEAT

1. Fasten seat /slide assembly studs (1, Figure 7) into slotted holes in hinge mounting plate (2, Figure 7) four places and fasten with four 5/16" flat washers and nuts.
2. Remove armrests (3, Figure 8) from box strap to the crate. Attach to seat with fasteners provided.

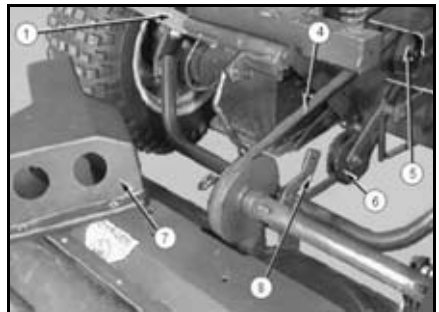

Figure 5

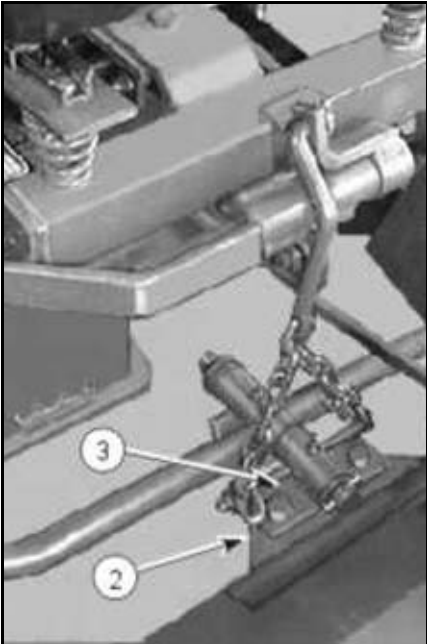

Figure 6

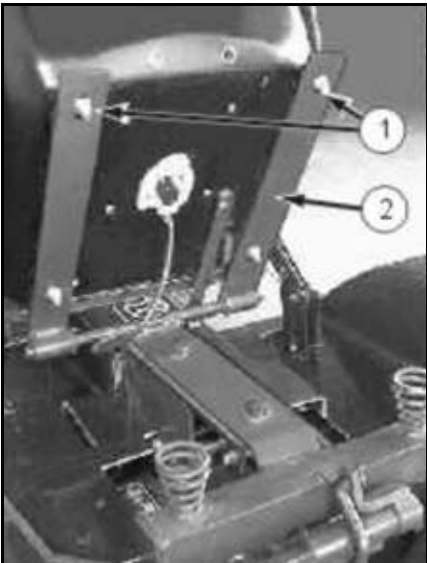

Figure 7

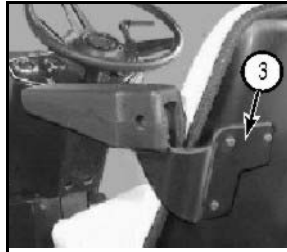

Figure 8

## STEERING WHEEL

1. Remove nut and washer (1, Figure 9) from steering shaft (2, Figure 9).
2. Remove steering wheel cap (3, Figure 9) from steering wheel (4, Figure 9).
3. Assemble steering wheel onto shaft, positioning the steering wheel cross bars parallel when the front tires are in the straight-ahead position and secure with the nut and washer. Replace steering wheel cap.

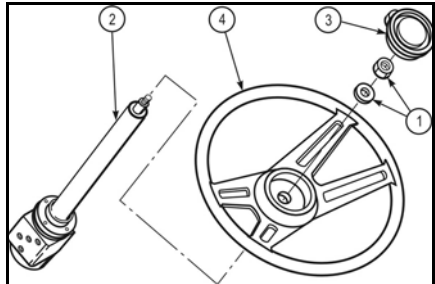

Figure 9

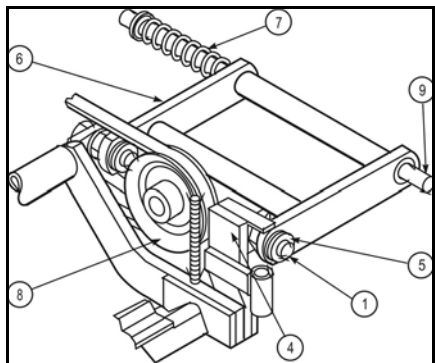

Figure 10

## WING MOWERS

1. Remove wing mowers from crate. Position on each side of tractor with the yoke pins (1, Figure 10) facing the tractor.
2. Remove the two wing mower belts (2, Figure 11) fastened to the rear cutting unit and install over lower countershaft pulleys (3, Figure 11) on each side of the tractor. Place belt loosely over the end of the wing mower pull yoke (4, Figure 10).
3. Move left and right cutting units into position so that the yoke pins enter the pivot holes in the pull yoke.

**NOTE:** Forward yoke pins must pass inside belt before attaching pins to pull yokes.

4. Secure yoke pins in pull yoke with 3/4" I.D. flat washers and 1/4" x 1-1/2" cotter pins (5, Figure 10). Extra washers supplied are to be used as spacers, if needed, to allow a snug but free-moving pivot connection.
5. Pull cutting units forward so that the H Frames (6, Figure 10) will compress the springs (7, Figure 10), and install belts over reel pulleys (8, Figure 10).
6. Compress belts by hand to check for free movement of the H-frames back and forth on the H-frame shafts (9, Figure 10).

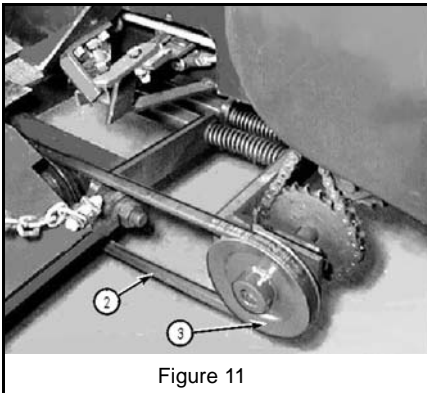

Figure 11

## WING MOWER LIFT

1. Position lift chain (1, Figure 12) that has been previously attached to lift lever (2, Figure 12) so that the longest chain extends away from the tractor.
2. Attach it to attachment tab (3, Figure 12) located on the middle of the front edge of the wing mower using a 3/8"-24 x 1-3/4" bolt, two 3/8" flat washers, and two 3/8"-24 lock nuts.
3. Place bolt through the ends of the chain so that lock nuts on each side of attachment tab allow chain to move freely between the flat washers.

4. Remove the cap screw (4, Figure 12) closest to the inside of the tractor fastening the shield to the cross bar.
5. Attach chain bracket (5, Figure 12), positioning the bracket with the longest leg to the outside of the cutting unit.
6. Fasten the shorter length of chain to the chain bracket by using similar fasteners and method described above.
7. Repeat lift chain installation procedure on the other side of the mower.
8. Test wing mower lift operation by pulling lift lever all the way back (toward the rear). Wing mowers should raise 2" to 3" above ground level. Adjust, if necessary, by fastening through another link in the chain at the upper end of the lift assembly.

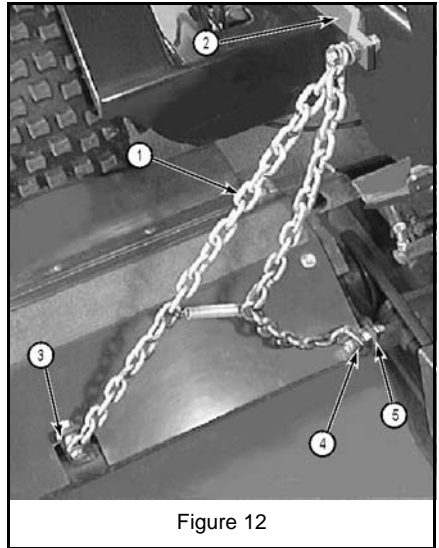

Figure 12

## ENGINE CRANKCASE

Crankcase oil has been installed at the factory. However, it is recommended that the engine be checked for proper oil level before starting. Refer to separate engine manual included with each 8400 Mower.

## HYDRAULIC OIL

1. The hydraulic oil has been installed in the oil tank (1, Figure 13) at the factory, however, it is recommended that the oil level be checked before operation.

2. Check oil level by removing pipe plug (2, Figure 13). The oil level should be at the bottom edge of the hole, as indicated by decal (3, Figure 13). If it becomes necessary to add a small amount of oil to the tank, it is added in the pipe plug hole, possibly using a flexible spout funnel.

Recommended oil is Chevron Rykon 100 or Exxon Univus N100, or equivalent hydraulic oil.

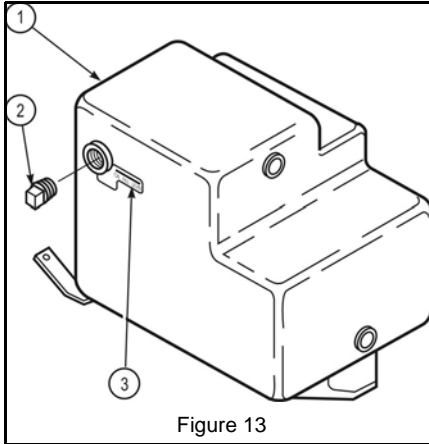

Figure 13

## BATTERY



**DANGER:** Read and follow the battery manufacturer's instructions on safety, maintenance and installation procedures.

The 8400 is not shipped with a battery. A group size 70, 12-volt side post battery is recommended such as Exide model 70-LT-60, which is approximately 7-3/16" high, 6-3/4" wide and 8-5/8" long.

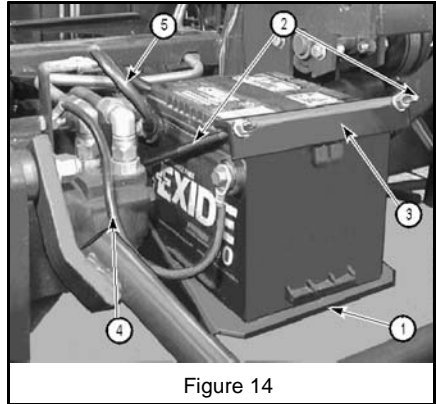

Figure 14

1. Place battery in battery holder (1, Figure 14) with terminals facing the left wheel. Insert the hook end of the battery support rods (2, Figure 14) into holes on the back vertical surface of the battery holder.
2. Place battery hold down (3, Figure 14) over support rods and upper corner of battery and secure with flat washers and hex nuts.
3. Attach the ground wire (4, Figure 14) to the frame as shown. Connect the ignition wire (5, Figure 14) to the positive (+) terminal of the battery.
4. Attach the ground wire last to the negative (-) terminal of the battery.

## SERVICE AND ADJUSTMENTS

Read each instruction completely, and make sure you understand it before making any adjustments. Follow all the safety precautions.



**DANGER:** To avoid possible serious injury, before making any adjustments or performing maintenance, engage parking brake, place all tractor controls in neutral, lower cutting units to the ground, turn ignition switch "off" and remove key.

2. To adjust the creep of the drive wheels, loosen the fastener attaching the ball bearing (3, Figure 15) to the control arm (4, Figure 15), and move and secure the bearing within the slot to achieve

### TRACTION PEDAL ADJUSTMENTS

The traction pedal (1, Figure 15) is equipped with a safety switch (2, Figure 15) and a neutral centering device. The switch prevents the engine from starting when the pedal is positioned in reverse or forward. The centering device locates neutral positioning of the pump.

1. Prior to adjusting for creep, elevate the wheels off the ground and support the vehicle with jack stands. Any adjustments should be done while the hydraulic oil is warm. neutral.



- Once the traction pedal has been adjusted, the safety switch (2, Figure 15) may have to be re-adjusted by moving the switch in the range of the slot provided in the switch bracket. Adjust the switch so that the engine cannot be started unless the pedal is in the neutral position.

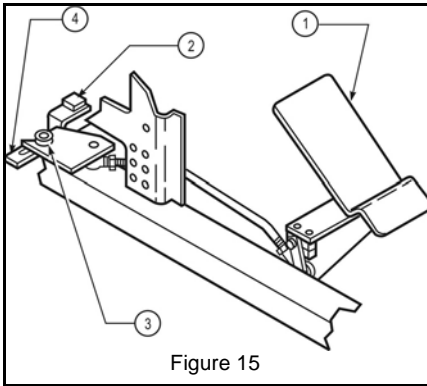

Figure 15

## UPPER COUNTERSHAFT BELT ADJUSTMENT

The upper countershaft belt is driven by the electric clutch located on the engine stub shaft.

Belt adjustment is taken up automatically by the torsion spring assisted idler arm; no adjustment is necessary. If belt slippage does occur, check the idler arm for free movement. If slippage still occurs, replace belt.

## PARKING BRAKE ADJUSTMENT

The parking brake should be set so that it holds the tractor securely. The parking brake must be released before the traction pedal is engaged.

- Adjust the brake by loosening set screw in the brake knob and turning knob clockwise to tighten, or counterclockwise to loosen, then retighten set screw.
- After making any adjustments, check brake on flat ground so that the tractor will not move with brake engaged.
- Test further by putting tractor on a hill, leave the engine on, and engage park brake. Then test with the engine off.

## GROUND SPEED CONTROL

The speed control (see *Speed Control* on page 9) is meant to ease operator fatigue by holding the forward speed constant.

Adjusting the hex head bolt (7, Figure 1) up or down and locking it with the lock nut will limit the pedal travel. Swing the speed control away from the traction pedal to allow a full range of forward speeds.

## WING MOWER BELT TENSION

Proper belt tension allows mowers to be driven without slippage but with belt loose enough to be deflected slightly at a point midway between pulleys. An overly tight belt will cause excessive belt wear. Never allow oil or grease to get on belt, which would cause slipping.

- The wing mowers must slide freely on pull rods to allow the pull yoke springs to properly tension the belt. If slippage occurs, it could be due to a weakened spring, a stretched belt, or sticky pull rods.
- Clean and oil pull rods frequently and check to see that H-frames are sliding freely on shafts.

## LOWER COUNTERSHAFT CHAIN ADJUSTMENT

Chain adjustment is taken up automatically by the torsion spring-assisted idler arm; no adjustment is necessary. Periodically check to see that the idler arm is free to pivot.

## REAR MOWER LIFT

The rear mower lift height has been preset at the factory and normally will not need to be adjusted.

## REAR MOWER DRIVE BELT TENSION

Rear mower belt adjustment is provided by a spring tensioned belt idler pulley (1, Figure 16). The idler pulley must be pressing down on the lower portion of the rear mower belt (2, Figure 16).

If further adjustment is necessary due to belt stretching, relocate the spacers (3, Figure 16) on the pull rod pivot from position 3 to position 4 (4, Figure 16), between the pull rod pivot and the rear mower pull plate.

If proper tension cannot be accomplished by the above procedure, replace the belt.

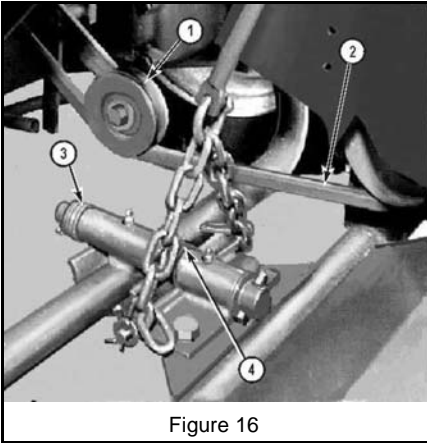

Figure 16

## HEIGHT OF CUT ADJUSTMENT

To set the height of cut, lift the Socket/Vinyl Cap of the Dial-A-Height™ (1, Figure 17) up then turn clockwise (viewed from above) to lower the roller (4, Figure 17) (raise the height of cut), or counter-clockwise to raise the roller (lower the height of cut).

**NOTE:** Each quarter turn (90°) of the Socket/Vinyl Cap will raise or lower the height of cut by approx. 1/32". A full turn (360°) will raise or lower the height of cut by approx. 1/8".

**IMPORTANT:** Rollers must be adjusted to the same height so that there will be uniform cutting the entire width of the mower.

The Height Adjustment Scale Decal (2, Figure 17) will provide approximate height of cut corresponding to the Socket/Vinyl Cap rotation.

1. Sight along the bottom edge of the Adjuster Tube (3, Figure 17) to achieve the desired cut height.
2. When making large adjustments to the height of cut (over 1/2"), it is easier to make small incremental adjustments to each side until the desired change is achieved, making sure the Socket/Vinyl Cap is locked in position.
3. If very accurate cutting heights are required, place a board or other gage plate (of desired thickness) on a smooth flat surface under each bedknife back bar (1, Figure 22) and adjust the roller height accordingly.

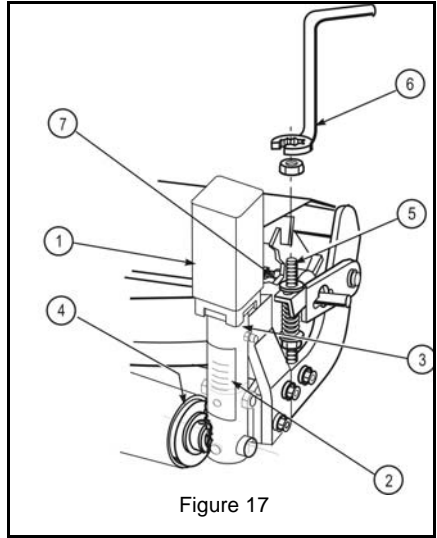

Figure 17

## REEL TO BEDKNIFE ADJUSTMENT



**DANGER:** Use heavy gloves and be careful. Bedknife and reel blades are very sharp.

The reel is adjusted to a fixed position bedknife. This makes a more rugged and durable frame and retains proper adjustment longer. The reel adjuster bolt (5, Figure 17) regulates the reel distance from the bedknife.

1. To reduce the distance, turn the locking hex nut on each side of the reel down with special reel adjustment wrench (6, Figure 17) and then tighten top nut.
2. Proceed slowly and do not over adjust—about 1/6 (one flat) of a turn on each side to begin with. Do not get the reel so tight that it is hard to turn by hand. A too tight reel will wear much faster. The reel should "wipe" or lightly touch the bedknife.
3. Check to see that blades are cutting the paper all the way across, using paper strips held between reel and bedknife.
4. Make sure adjustment nuts are tight before mowing.

## REEL END PLAY ADJUSTMENT

As the reel is used, normal wear of the reel bearings will cause end play. This condition could cause uneven wear to moving parts and uneven cutting of turf.

Test for end play periodically by trying to move the reel from side to side in the frame. If there is any movement, end play is present.

1. Loosen the lock nut on the adjustment screw (7, Figure 17) and (Figure 18), (inside right end of the reel) and turn adjustment bolt in 1/2 turn or less. Do not over tighten as excessive bearing wear can occur.
2. Test again for endplay. If reel is rotating freely and endplay can not be detected, retighten the locking nut on adjustment bolt.

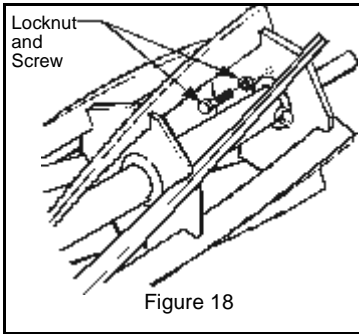

Figure 18

## VERTICAL MOWING UNIT - BLADE CHANGING

1. To change the blades, remove the vertical mowing unit from the frame. Unbolt the (2) hangers (see Parts Manual) from the frame.
2. Remove bearing from the hangers. Remove by loosening the bearing collet setscrews.

**NOTE:** It is also advised to check the bearings for wear and replace if necessary.

3. Remove nut from the shaft and slide the blade and spacer off.
4. Reassemble with new blades. Make sure you time the blades so they are on a spiral and so that the blades are pointed in the proper direction. Check to make sure there is no side play with the blades when tightening the nut.
5. Re-attach the vertical mowing unit to the frame.

## BACKLAPPING PROCEDURE

Backlapping is a very important step in maintaining sharp reel blades on the rear and wing mowers.

This procedure should be performed when the reel blades and bedknife become slightly rounded and the grass cannot be cut cleanly after adjusting the reel to bedknife clearance (see *REEL TO BEDKNIFE ADJUSTMENT* on page 18).



**DANGER:** Be extremely careful not to let tools, your fingers, or clothing get caught in the reels. Use approved safety glasses to protect eyes from flying particles and abrasives.

1. Make sure to adjust the reel to the bedknife so that the reel is parallel with the bedknife and light contact is maintained.
2. Reels must be run in reverse direction to be lapped. Remove drive belts and attach a backlapping machine to the reel. Follow the instructions furnished by the backlapping machine manufacturer.
3. With reel running, apply the lapping compound using a 2" or 3" wide brush. Apply the compound evenly to the mowing blades.
4. Stop the reel and examine both bedknife and reel blades to see that the cutting edges are uniformly sharp. If not, gradually tighten nut adjuster (see *REEL TO BEDKNIFE ADJUSTMENT* on page 18), and repeat step 3 above until the proper sharpness results.
5. Rinse off the compound thoroughly with water to remove all abrasives. Check for sharpness and readjust the bedknife if necessary.
6. Check reel adjustment on each mower and adjust if necessary so that they will cut paper cleanly across the full length of the bedknife when paper is held 90° to the bedknife and pinched when held horizontally.

Many types of compounds are available for lapping. However, we recommend a good pre-mixed water-soluble compound. Premixed compound saves the time required to mix, eliminates the waste, and is available in all grit ranges from coarse to extra fine. Contact your local Dealer for types and ordering information.

## LAPPING COMPOUND

See your authorized Dealer to order these lapping compounds.

Lapping Compound	
80 Grit – 1-lb.	02841500
80 Grit – 11-lb.	59501400
80 Grit – 25-lb.	59501700
100 Grit – 10-lb.	02071600
120 Grit – 11-lb.	59501500
120 Grit – 25-lb.	59501800
180 Grit – 11-lb.	59501600
180 Grit – 1-lb.	02841600
180 Grit – 25-lb.	59501900
220 Grit – 1lb.	02841800
220 Grit – 25-lb.	59502000

## GRINDING PROCEDURE

Reel must be ground at 25° in the direction shown (Figure 19). Back grind until reel blades are free from roundness, dents, and nicks. Spin grind to remove all burrs. All blades must be on the same diameter.

After grinding the bedknife and reels, backlap to establish a perfect match between the bedknife and reel blades.

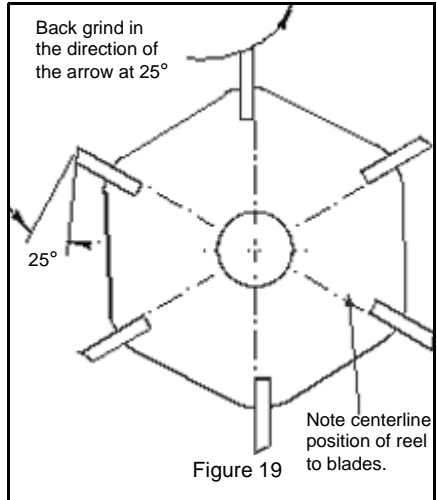

For maximum cutting efficiency, grind bedknife top and front edges at 5° (see Figure 20).

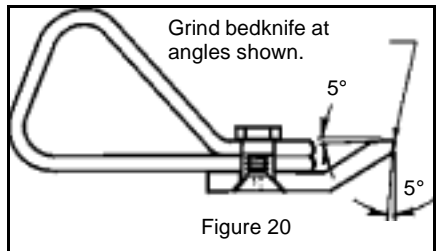

# MAINTENANCE



**DANGER:** To avoid possible serious bodily injury, before performing any adjustments, maintenance, or lubrication, place all controls in “neutral,” lower the mowers to the ground, engage parking brake, turn ignition switch off, and remove key.

## GENERAL MAINTENANCE

The long trouble-free life of your machine depends on the maintenance it receives. Set up a maintenance program for your 8400 to cover the following points:

- Keep tractor and mowers clean.
- Keep all moving parts properly lubricated (see *LUBRICATION* on page 23).
- Keep all parts properly adjusted.
- Inspect for loose, worn or damaged parts.
- Keep shields in place at all times.
- Keep tires properly inflated.

If your inspection reveals worn or damaged parts, replace these parts before operating machine or before actual breakdown occurs.



**DANGER:** To avoid injury from hot, high-pressure oil, never disconnect hydraulic hoses with attachments in up position. Never rub hands across tubes, hoses, or fittings to check for leaks. Hydraulic fluid escaping under pressure can have sufficient force to penetrate the skin.

## ASSEMBLY AND DISASSEMBLY

Use the illustrations in the Parts Manual as reference for disassembly and assembly of components. Always maintain relative position of parts when disassembling. Clean and lubricate individual parts and components as required.

## BATTERY

1. Make certain the ignition switch is in the “off” position and the keys have been removed.
2. Refer to the Mower Specifications in this manual for battery specifications.
3. Connect charger leads to battery. Connect the positive (+) connector from the charger to the positive battery terminal. Connect the negative (-) connector of the charger to the negative



**DANGER:** Always wear protective glasses or goggles and protective clothing when working with batteries. Always connect the “ground” (black) cable last and remove it first whenever performing any maintenance. Batteries contain sulfuric acid and generate explosive mixtures of hydrogen and oxygen gases. Keep any device which may cause sparks or flames away from the battery to prevent explosions. Read and follow the battery manufacturer’s instructions on safety, maintenance, and installation procedures.

3. When the battery is being installed or removed, make sure that the positive and negative terminals do not come in contact with metal tractor parts at the same time, or severe damage may result.
4. Battery connections must be kept clean and tight at all times. Loose cables will cause eventual battery failure. Keep terminal covers in place.
5. Use soap and water to clean the battery as required. Care must be taken to prevent soap and water from getting inside battery.
6. Clean the terminal contact surfaces with a battery terminal brush or steel wool.
7. Tighten cables securely to battery terminals.
8. Apply a light coat of petroleum jelly or chassis lubricant to terminals and cable ends after assembly to prevent corrosion.

## CHARGING A BATTERY



**DANGER:** To avoid possible injury, stand away from battery when charger is turned on. A damaged battery or a battery with an internal short could explode.

Charge battery only in a well-vented location, away from sparks or open flame.

1. Remove the battery from the tractor before charging.
2. Be sure charger is “off.” battery terminal.
4. Charge the battery using one of the methods shown below. Follow the manufacturer’s instructions on the charger.

Slow charge:

- 10 hours @ 5 amps
- 3 hours @ 10 amps

Fast charge:

- 2-1/2 hours @ 20 amps
  - 1-1/2 hours @ 30 amps
  - 1 hour @ 45 amps
5. If when charging the battery, violent gassing or spewing of electrolyte occurs, or the battery case feels hot (125°F - 52C), reduce or temporarily halt charging to avoid damaging battery.
  6. Always turn charger to "off" before removing a charger lead from the battery.

## JUMPER CABLES

The battery on the 8400 is located at the rear of the tractor (see Figure 14).

1. Stop the engine on the vehicle with the good battery.
2. Connect one jumper cable to the positive terminal on the good battery. Connect the other end of the jumper cable to either the positive terminal on the dead battery or the battery side of the solenoid located on the right front of the engine.
3. Connect one jumper cable to negative terminal on dead battery. Connect the other end to ground (frame) of vehicle with the good battery.

## BELTS

For efficient performance of your machine, worn or frayed belts must be replaced. Check belt tensions as instructed (see *SERVICE AND ADJUSTMENTS* on page 16).

## ENGINE FUEL FILTER

Before servicing the fuel filter, thoroughly clean outside of filter housing and fuel hoses. Dirt must not be allowed to enter into fuel or fuel system. Refer to manufacturer's Engine Manual for instructions.

## ENGINE

Refer to manufacturer's Engine Manual for maintenance schedule recommendations. Change oil and oil filter after the first 5 to 8 hours of operation.

## ELECTRICAL SYSTEM

Make certain all terminals and connections are kept clean and properly secured.

1. Check switches regularly to be sure they are kept clean and operating correctly.

2. Keep wire harness and all individual wires away from moving parts, hot parts, or sharp edges. This will prevent abrasive wear or potential short circuits.
3. Exercise extreme care when working with electrical system.

## HYDRAULIC HOSES



**DANGER:** To avoid serious bodily injury, always lower mowers to the ground, place all controls in neutral and shut off engine before inspecting hydraulic lines or hoses. Never run hands across tubes, hoses or fittings to check for leaks.

Hydraulic hose and tube lines should be inspected every week to check for cuts, loose connections, kinks, and wear.

Be sure tubes and hoses do not come in contact with other frame parts which could cause abrasive wear. Always replace worn hoses or tubes before operating machine.

1. Assemble nut, sleeves and tube to fitting body with minimum torque (finger tight) until flare contacts seat on fitting body.
2. For tightening reference, mark a line lengthwise on both the nut and adapter fitting with a marker.
3. Using a wrench, rotate the nut to tighten. Turn the nut to the amount shown in the chart below. The line will show which fitting has been tightened and how much.
4. On hoses with "o-ring" fittings, make sure o-rings are clean and hose fittings are properly seated by hand before wrench tightening.
5. Hold the fixed portion of the hose coupling with one wrench; use a second wrench to tighten or loosen the hose nut. This will prevent damage to the fitting seal. When tightening a hose, do not allow it to twist; hold it in a normal, straight position.

Tube O.D. or Hose	Rotate # of Flats
3/8"	2
1/2"	2
5/8"	1-1/2-2
1"	3/4-1

## HYDRAULIC OIL FILTER

To prevent damage to the hydraulic system, the hydraulic oil filter (1, Figure 21), located under right fender, should be changed after the first 25 hours of operation and every 250 hours thereafter.

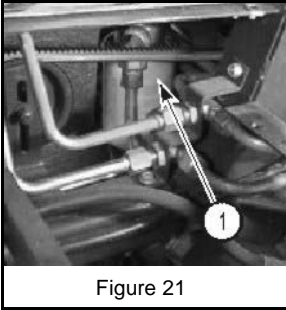

Figure 21

1. Remove the old filter.
2. Install new filter, filling filter with oil before re-installing. Apply oil to the o-ring of the filter prior to installation. Hand-tighten only.
3. Run engine at idle speed with hydrostatic pump in neutral for five minutes.
4. Check hydraulic oil level, and add oil if necessary. Frequently check oil level in the hydraulic tank. Should the pump run short of oil, immediate and permanent damage will result.

## BEDKNIFE REPLACEMENT

When the bedknife becomes damaged or too worn to keep sharp, it must be replaced. Follow the procedure below.

1. The backbar (1, Figure 22), bedknife (2, Figure 22), and fasteners have been assembled at the factory under tension. To ease replacement and prevent misalignment of components, you may wish to clamp the leading edge of the backbar two or three places before removing the old fasteners.
2. Remove shoulder nuts (3, Figure 22) and flathead screws (4, Figure 22). If shoulder nuts are badly rusted or corroded, they may have to be cut off and the screws driven out.
3. Clean the bottom surface of the backbar for maximum metal contact with the new bed bar.
4. Fasten the new bed knife to the bottom of the backbar in the position shown (bent edge up). Shoulder of shoulder nuts must be seated firmly in the backbar and screws must be flush with the bottom of the bed knife.

5. Torque shoulder nuts 35 to 40 lbf/ft (47.4 to 54.2 N·m).

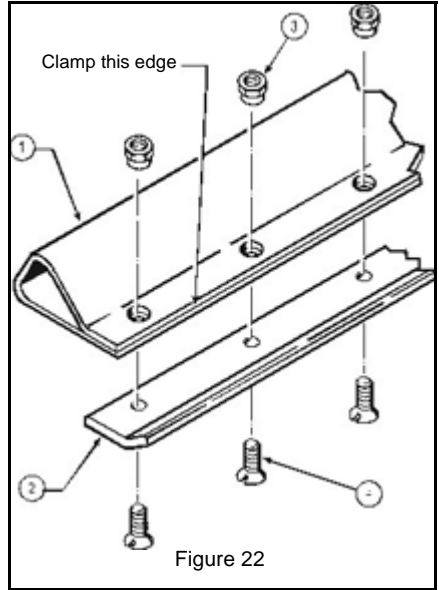

Figure 22

## LUBRICATION

Figure 23 shows the top view of the 8400 with guards removed. Lubricate your tractor at the recommended locations and intervals using proper lubricants so that maximum service and long life of the machine may be obtained.



**CAUTION:** Before doing any work on your machine, stop the engine, remove the ignition key, and set parking brake.

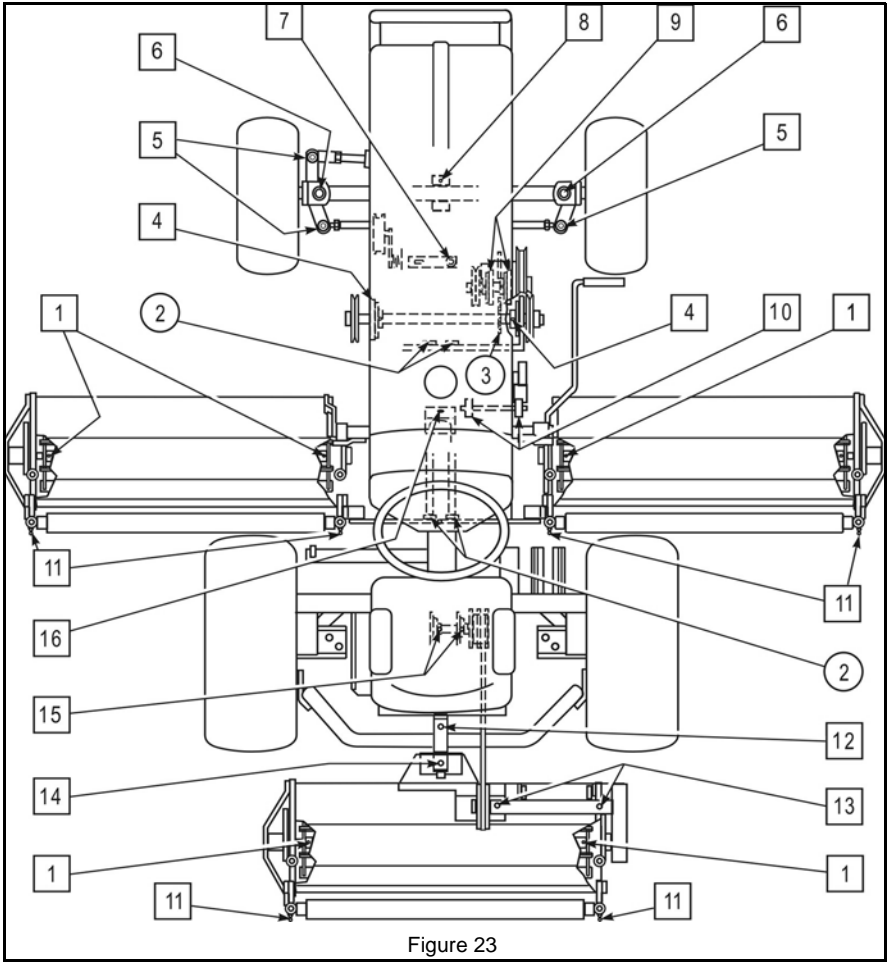

Figure 23

**Symbols**

- GREASE - Lithium base or Equivalent
- OIL - Light machine oil.



<b>Item</b>	<b>Frequency (Hrs.)</b>	<b>Location</b>	<b>Type of Lubrication</b>	<b>No. of Places</b>
1	Daily	Mower Reel Roller Bearing	Grease, Lithium	6
2	Daily	Wing Mower Pull Rod Bushing	Oil	4
3	Daily	Idler Sprocket Chain	Oil	1
4	Daily	Lower Countershaft Bearing	Grease, Lithium	2
5	25	Front Axle Ball Joints	Grease, Lithium	3
6	Daily	Axle Yoke	Grease, Lithium	2
7	25	Neutral Return Pivot	Grease, Lithium	1
8	25	Front Axle Pivot	Grease, Lithium	1
9	25	Upper Countershaft Bearing	Grease, Lithium	2
10	Daily	Pedal Support Bearing	Grease, Lithium	2
11	Daily	Roller Bracket Bushing	Grease, Lithium	6
12	25	Rear Mower Pull Yoke Pivot	Grease, Lithium	1
13	Daily	Rear Mower Countershaft	Grease, Lithium	2
14	25	Rear Mower Lifter Bracket Pivot	Grease, Lithium	1
15	Daily	Countershaft Bearing	Grease, Lithium	2
16	Yearly	Steering Motor	Grease, Lithium	1

# STORAGE

## GENERAL INSTRUCTIONS

When you do not plan to use your vehicle for some time, it should be stored in a dry and protected place. Unnecessary exposure to the elements may deteriorate its appearance and shorten the usual service life.

## ENGINE

1. Drain the fuel from the fuel tank and carburetor.
2. Operate the engine until the gasoline in the carburetor is completely consumed.
3. While the engine is still warm, drain the oil from the crankcase and refill with fresh oil. Refer to Engine Manual for manufacturer's instructions.
4. After engine has cooled, remove the spark plugs and put about one tablespoon of SAE 30 oil into the cylinder.
5. Clean exterior of engine. Paint the exposed metal or coat it with a light coating of rust preventative oil.

## BATTERY

1. Remove battery and clean it. Refer to manufacturer's manual for specific instructions.
2. Maintenance-free batteries should be stored in an upright position in a cool dry place. Storage above 80° F (28 °C) greatly increases self-discharge. If wet batteries are discharged, the electrolyte will freeze when stored below 20° F (-7 °C).

**IMPORTANT:** The battery should be checked every 60 to 90 days while in storage and should be recharged if necessary.

## TRACTOR

Wash, clean and completely lubricate the tractor. Paint any exposed metal.

## TIRES

1. Before storing the vehicle, clean the tires thoroughly.
2. Jack up the vehicle so that the load is off the tires. If it is not jacked up, check the tires at regular intervals and re-inflate as necessary to keep them at the recommended maximum pressure (Indicated on tire's side wall).
3. Store the vehicle so that the tires are protected from sunlight.

## STARTING THE ENGINE AFTER STORAGE

If mower is cold, move the mower to a heat location and allow it to come to room temperature (70°F - 22°C) before starting. This will prevent premature wear of hydraulic system components.

Follow the towing procedure (see *PUSHING OR TOWING INSTRUCTIONS* on page 12).

1. Check and recharge the battery according to recommendations (see *CHARGING A BATTERY* on page 21).
2. Reinstall the battery
3. Check oil level in crankcase and hydraulic oil tank.
4. Fill the fuel tank with fresh gasoline. Check fuel filter. Check fuel shut off valve; open if necessary.
5. Before driving the vehicle, check to make certain that the tires are properly inflated to the proper pressure.



**CAUTION:** Avoid injury! Explosive separation of tire and rim parts is possible when they are serviced incorrectly:

- Do not attempt to mount a tire without the proper equipment and experience to perform the job.
- Do not inflate the tires above the recommended pressure.
- Do not weld or heat a wheel and tire assembly. Heat can cause an increase in air pressure resulting in an explosion. Welding can structurally weaken or deform the wheel.
- Do not stand in front or over the tire assembly when inflating. Use a clip-on chuck and extension hose long enough to allow you to stand to one side.

6. Remove the spark plugs and wipe dry. Crank the engine (with spark plug removed) using the starter until excess oil has been expelled through the spark plug hole. Replace the plug and connect the ignition lead wires.
7. Move the vehicle outdoors or keep doors and/or windows wide open to provide sufficient ventilation before starting engine. This will prevent danger from carbon monoxide gas in the exhaust.
8. Start the engine but do not operate at high speed immediately after starting. Allow time for it to become properly warmed and lubricated.

## TROUBLESHOOTING

### ENGINE WILL NOT START

- The operator must be seated.
- Check position of reel control switch (on dash). Switch must be in the OFF position.
- Check to see that the traction pedal is in neutral (neutral is in the center position).
- Check all safety switches for conductivity.
- Replace switches, if necessary.
- Check fuel in tank.
- Check if fuel is at the end of fuel line at carburetor. If not, clean filter or, if necessary, replace fuel filter.
- Check battery. Check charge level; charge or replace as needed. Clean battery terminals, if necessary.
- Check spark plugs. Check for spark at spark plugs, check for foul conditions, or replace spark plugs, if necessary. Refer to Briggs and Stratton engine manual for recommended spark plug and gap.
- Check electrical wiring and safety switch operation. Check wiring or check traction pedal neutral safety switch and adjust to allow current flow from the "S" terminal to the starter solenoid.

### TRACTOR WILL NOT MOVE

- Check that parking brake is not engaged.
- Check towing (free-wheeling) valve to see that it is fully closed (in the down position).
- Check the linkage from the traction pedal to the pump control mechanism to ensure complete attachment of all linkages.

### REEL WILL NOT TURN

- Check for debris jammed between the reel and bedknife.
- Check for proper belt tension. Belt tension is not adjustable.
- Test wing mower H-frames so that they are sliding easily. Lubricate, if necessary.
- Check rear mower belt tension idler to see that idler is moving freely.
- Check drive belts between engine clutch and countershaft pulley to ensure that spring loaded idler is moving freely. If slippage still occurs as a result of belt wear and belt stretch, replace belt.

### REEL WILL NOT CUT

- Check the reel to bedknife clearance with common newspaper. The reel should cut through paper the entire length of the bedknife.
- Inspect reel and bedknife for damage. Service, if necessary.
- If reel is cutting grass too high, too low, or not at all, the reel height is out of adjustment. See *HEIGHT OF CUT ADJUSTMENT* on page 18.
- If reel is cutting grass unevenly from side to side or not at all, the distance between the reel and the bedknife is out of adjustment. See *REEL TO BEDKNIFE ADJUSTMENT* on page 18.

## SPECIFICATIONS

<b>Model Number</b>	995005
<b>Engine</b>	
Type	Twin Cylinder, Air Cooled
Model	Briggs & Stratton Vanguard
Horsepower	16HP (11.9 kW)
Cooling	Ducted Airflow
<b>Transmission</b>	
Traction Drive	Model 11 Variable
	Displacement
	Hydrostatic Pump
Wheel Drive Motors	Eaton Series 2000 Hydraulic Motor
<b>Steering</b>	
Eaton Power Steering Control Unit	
<b>Mower</b>	
Fuel Tank	5 Gallons (19 liters)
Oil Tank	5 Gallons (19 liters) Approx.
Tires	Front: 16x6.50 - 8 (28 psi (1.9 bar) max) Rear: 23x10.50x12 (20 psi (1.4bar) max)
Frame	Welded Steel Construction
Mowing Speed	0-7 MPH (0-11.3 KM/H)
Controls	Foot-operated Traction Pedal for Forward & Reverse Hand-operated Throttle and Choke Controls Free-wheeling Tow Valve Electric Clutch for Cutting Units Hand-operated Parking Brake
Battery Type	Exide Model 70-LT-60 Group Size 70 12-V Side Post 7-3/16" (18 cm) Height 6-3/4" (17 cm) Width 8-5/8" (22 cm) Length
<b>Cutting Unit</b>	
Unit	3-30" (.76 m) Long Reels
Reels	8" (20.3 cm) Diameter, 6 or 8 Blade
Bearings	Timken Tapered Roller
Bedknife	13 x 64 x 2" with Upturned Lip of Alloy Steel (5.16mm x 50mm)
Width of Cut	84" (2.13m)
<b>Lubricants</b>	
Engine Oil	Refer to Enclosed Engine Manual
Hydraulic Oil	Texaco Rando HDZ 100 Chevron Rykon 100 or Exxon Univus N100 or Equivalent
<b>Vertical Mowing Unit</b>	
Cutting Unit	3-30" (.76m) Long Reels
Reels	10" (25.4cm) Diameter, 26 Blades, 1" (2.54cm) Spaced
Bearings	PEER Bearing Block
Width of Cut	84" (2.13m)
Height of Cut	-3/8" to 1/2" (-.96 cm to 1.27 cm) Adjustment



# Two-Year Limited Turf Products Warranty

Ariens Company (Ariens) warrants to the **original purchaser** that all Gravely Turf, Locke Turf or National Mower brand commercial turf products will be free from defects in material and workmanship for a period of two years after the date of purchase or 1000 hours of use, whichever comes first. An authorized Gravely Turf, Locke Turf or National Mower dealer will repair any defect in material or workmanship, and repair or replace any defective part, subject to the conditions, limitations and exclusions set forth herein. Such repair or replacement will be free of charge to the **original purchaser** (labor and parts), except as noted below.

## ***One-Year Limited Warranty on i-Trim Mowers and Pro Vac Lawn Vacuums***

Ariens Company (Ariens) warrants to the **original purchaser** that all Gravely Turf, Locke Turf or National Mower brand i-Trim mowers or Pro Vac lawn vacuums will be free from defects in material and workmanship for a period of one year after the date of purchase or 500 hours of use, whichever comes first. An authorized Gravely Turf, Locke Turf or National Mower dealer will repair any defect in material or workmanship, and repair or replace any defective part, subject to the conditions, limitations and exclusions set forth herein. Such repair or replacement will be free of charge to the **original purchaser** (labor and parts), except as noted below.

## ***90-Day Limited Warranty on Service Parts and Accessories***

Genuine Gravely Turf, Locke Turf or National Mower brand service parts and accessories are warranted to be free from defects in material and workmanship for a period of 90 days after the date of purchase. An authorized Gravely Turf, Locke Turf or National Mower dealer will repair or replace any such part or accessory free of charge, except for labor, during that period.

If any product is rented or leased, then the duration of these warranties shall be 90 days after the date of purchase.

## **Exceptions, Limitations, Exclusions**

### ***Customer Responsibilities***

**Register the product immediately at the time of sale.** If the dealer does not register the product, the customer must complete the product registration card in the literature package and return it to the Ariens Company, or register the unit online at [www.ariens.com](http://www.ariens.com), [www.gravely.com](http://www.gravely.com), or [www.nationalmower.com](http://www.nationalmower.com).

To obtain warranty service, the **original purchaser** must:

- Perform the maintenance and minor adjustments explained in the owner's manual.
- Promptly notify Ariens or an authorized Gravely Turf, Locke Turf or National Mower service representative of the need for warranty service.
- Transport the product to and from the place of warranty service.
- Have the warranty service performed by an authorized Gravely Turf, Locke Turf or National Mower service representative.

To find a Gravely Turf, Locke Turf or National Mower authorized service representative, contact Ariens at:

655 W. Ryan Street  
Brillion, WI 54110  
(920) 756 - 2141  
[www.ariens.com](http://www.ariens.com)  
[www.gravely.com](http://www.gravely.com)  
[www.locketurf.com](http://www.locketurf.com)  
[www.nationalmower.com](http://www.nationalmower.com)

### ***Limitations***

- Batteries are warranted only for a period of 12 months after date of purchase, on a prorated basis. For the first 90 days of the warranty period, a defective battery will be replaced free of charge. If the applicable warranty period is more than 90 days, Ariens will cover the prorated cost of any defective battery, for up to 12 months after the date of purchase.

## Exclusions – Items Not Covered by This Warranty

- Engines and engine accessories are covered only by the engine manufacturer's warranty and are not covered by this warranty.
- Parts that are not genuine Gravely Turf, Locke Turf or National Mower service parts are not covered by this warranty.
- The following maintenance, service and replacement items are not covered by this warranty unless they are noted in the Limitations section above: lubricants, spark plugs, oil, oil filters, air filters, fuel filters, brake linings, brake arms, shoes, runners, scraper blades, shear bolts, mower blades, mower vanes, headlights, light bulbs, knives, cutters.
- Mufflers, belts and tires on Gravely Turf, Locke Turf or National Mower turf products are not covered by this warranty.
- Any misuse, alteration, improper assembly, improper adjustment, neglect, or accident which requires repair is not covered by this warranty.
- This warranty applies only to products purchased in the United States (including Puerto Rico) and Canada. In all other countries, contact place of purchase for warranty information.

### **Disclaimer**

Ariens may from time to time change the design of its products. Nothing contained in this warranty shall be construed as obligating Ariens to incorporate such design changes into previously manufactured products, nor shall such changes be construed as an admission that previous designs were defective.

### **LIMITATION OF REMEDY AND DAMAGES**

Ariens Company's liability under this warranty, and under any implied warranty that may exist, is limited to repair of any defect in workmanship, and repair or replacement of any defective part. Ariens shall not be liable for incidental, special, or consequential damages (including lost profits). Some states do not allow the exclusion of incidental or consequential damages, so the above limitation or exclusion may not apply to you.

### **DISCLAIMER OF FURTHER WARRANTY**

**Ariens Company makes no warranty, express or implied, other than what is expressly made in this warranty. If the law of your state provides that an implied warranty of merchantability, or an implied warranty of fitness for particular purpose, or any other implied warranty, applies to Ariens Company, then any such implied warranty is limited to the duration of this warranty. Some states do not allow limitations on how long an implied warranty lasts, so the above limitation may not apply to you.**

*This warranty gives you specific legal rights, and you may also have other rights which vary from state to state.*





National Mower  
An Ariens Company  
655 West Ryan Street  
Brillion, WI 54110-0157  
920-756-2141  
Fax 920-756-2407  
[www.nationalmower.com](http://www.nationalmower.com)

 **WARNING** 

The engine exhaust from this product contains chemicals known to the State of California to cause cancer, birth defects or other reproductive harm.