

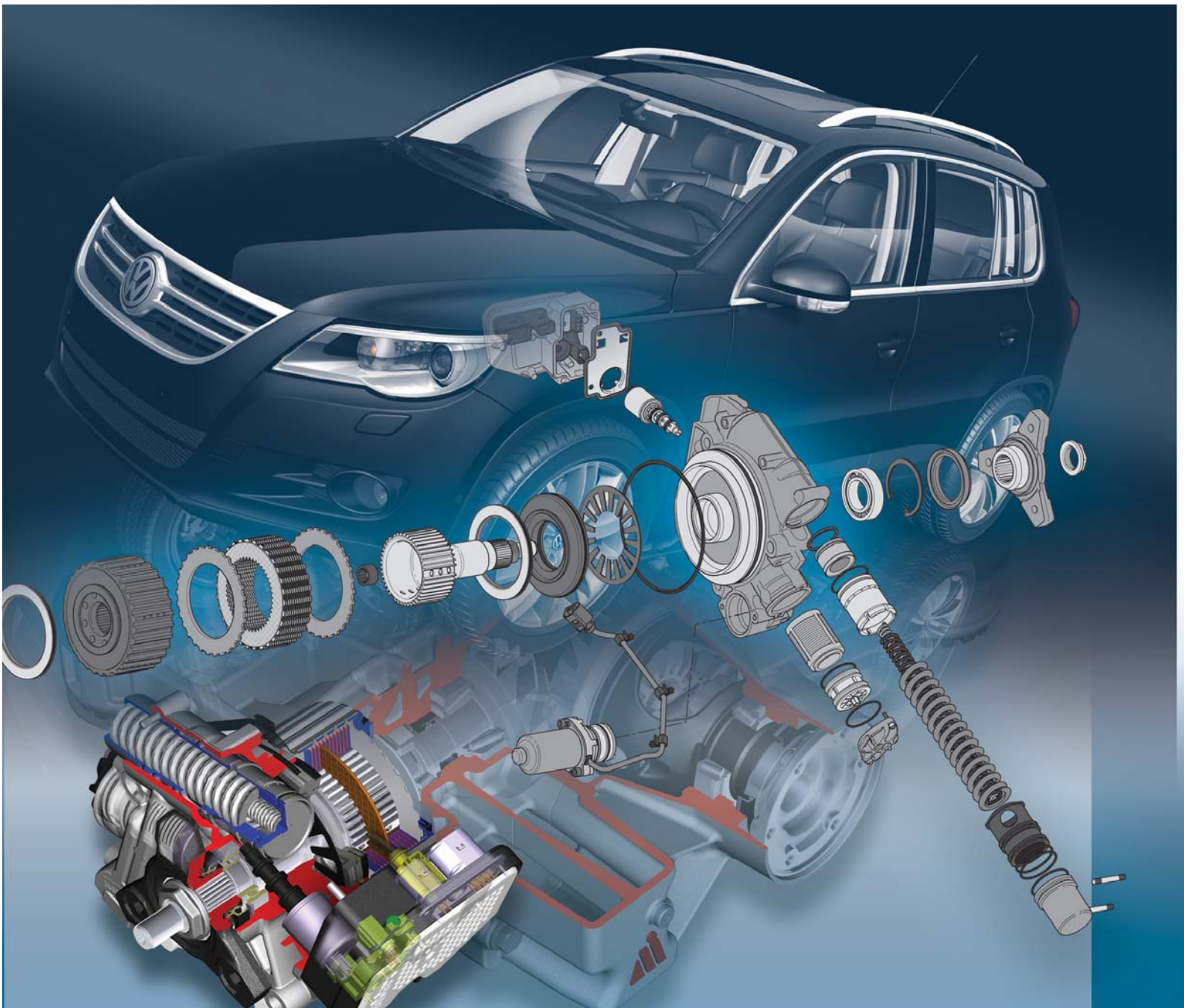

Self Study Program 861803

Tiguan Haldex All-Wheel Drive



Volkswagen of America, Inc.
Volkswagen Academy
Printed in U.S.A.
Printed 1/2008
Course Number 861803

©2008 Volkswagen of America, Inc.

All rights reserved. All information contained in this manual is based on the latest information available at the time of printing and is subject to the copyright and other intellectual property rights of Volkswagen of America, Inc., its affiliated companies and its licensors. All rights are reserved to make changes at any time without notice. No part of this document may be reproduced, stored in a retrieval system, or transmitted in any form or by any means, electronic, mechanical, photocopying, recording or otherwise, nor may these materials be modified or reposted to other sites without the prior expressed written permission of the publisher.

All requests for permission to copy and redistribute information should be referred to Volkswagen of America, Inc.

Always check Technical Bulletins and the latest electronic repair information for information that may supersede any information included in this booklet.

Trademarks: All brand names and product names used in this manual are trade names, service marks, trademarks, or registered trademarks; and are the property of their respective owners.

Contents

Introduction	1
Overview	2
Drivetrain	4
All-Wheel Drive Clutch Details	9
Controls	17
Service	23
Knowledge Assessment	25

This Self-Study Program provides information regarding the design and function of new models. This Self-Study Program is not a Repair Manual.

This information will not be updated. For maintenance and repair procedures, always refer to the latest electronic service information.

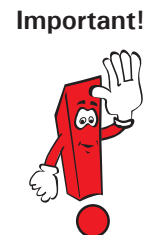
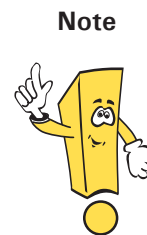



Page intentionally left blank

Introduction

Volkswagen has used a Haldex clutch for the 4MOTION all-wheel drive since 1998. A new generation of the all-wheel drive clutch is now used by Volkswagen for the first time in the Tiguan.

The new all-wheel drive clutch is controlled electronically. It allows torque to be transmitted to the drive wheels that have traction regardless of

slip at other wheels. The distribution of the drive forces to the axles is variable and depends on the driving conditions. The new all-wheel drive clutch in 4MOTION responds rapidly to any driving situation and maintains the best possible traction at all times.

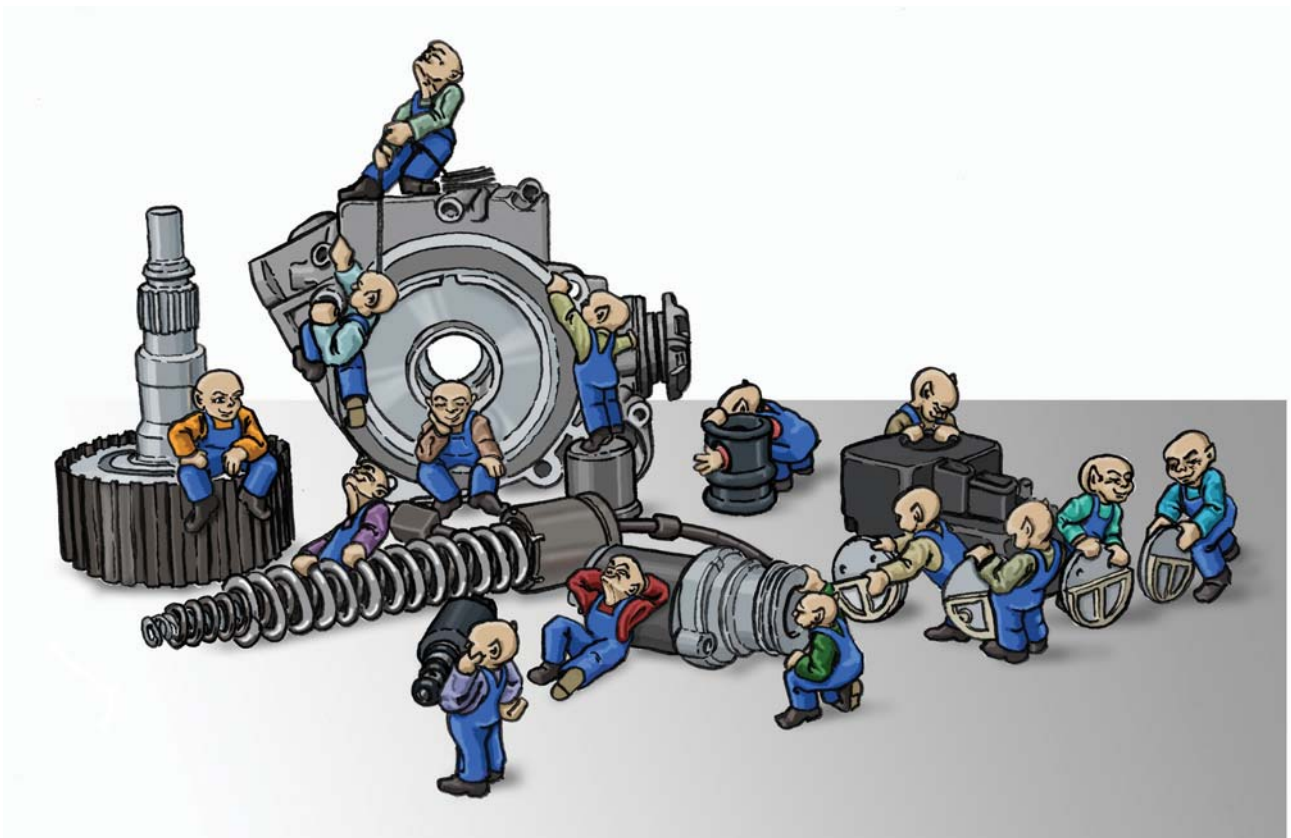

S414_002

Overview

History

In 1998, 4MOTION drive replaced synchro all-wheel drive at Volkswagen. While the synchro all-wheel drive used a visco clutch, an all-wheel clutch by Haldex was used for the first time in the 4MOTION drive.

With this hydraulic multiplate clutch, the all-wheel drive could be controlled electronically. Apart from slip control, the control module also allowed handling dynamic driving conditions such as curves, speed, and overrun, or load operation.

Function of Haldex Clutches

The first two generations of the Haldex clutch use a rotational speed difference between the front and rear axles to operate. A pump effect is generated using a cam plate, rollers, and two reciprocating pistons working in parallel. This creates oil pressure that compresses the multiplate clutch through a working piston. The drive torque transferred determines the amount of pressure applied.

The pressure on the multiplate disks of the clutch is regulated through:

- Suction valves
- Pressure valves
- Electronic control valve
- Control module

First Generation Haldex Clutch



S414_003

Generation II Haldex Clutch from Model Year 2004

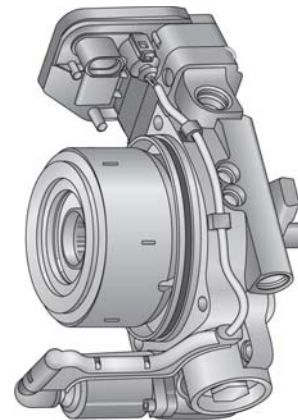

S414_004

Haldex Generation IV All-Wheel Drive Clutch

The power transfer through the multiplate pack of the generation IV all-wheel drive clutch is nearly identical to the previous Haldex models. Generating the pressure with an electric pump is a new feature. The torque to be transferred is determined by All Wheel Drive Control Module J492 through the selection of Haldex Clutch Control Valve N373. Speed differences between the front and rear axles are no longer a prerequisite for activating the all-wheel drive clutch.

Technical Features

- Electro-hydraulically controlled multiplate clutch
- Integrated in the rear axle drive
- Simplified hydraulic circuit
- Optimized demand-controlled pump selection

Advantages

- Clutch selection independent from the driving situation
- Rapid torque build-up
- Permanent rear wheel drive capacity
- Unrestricted compatibility with the slip control systems (e.g. ESP, ABS)

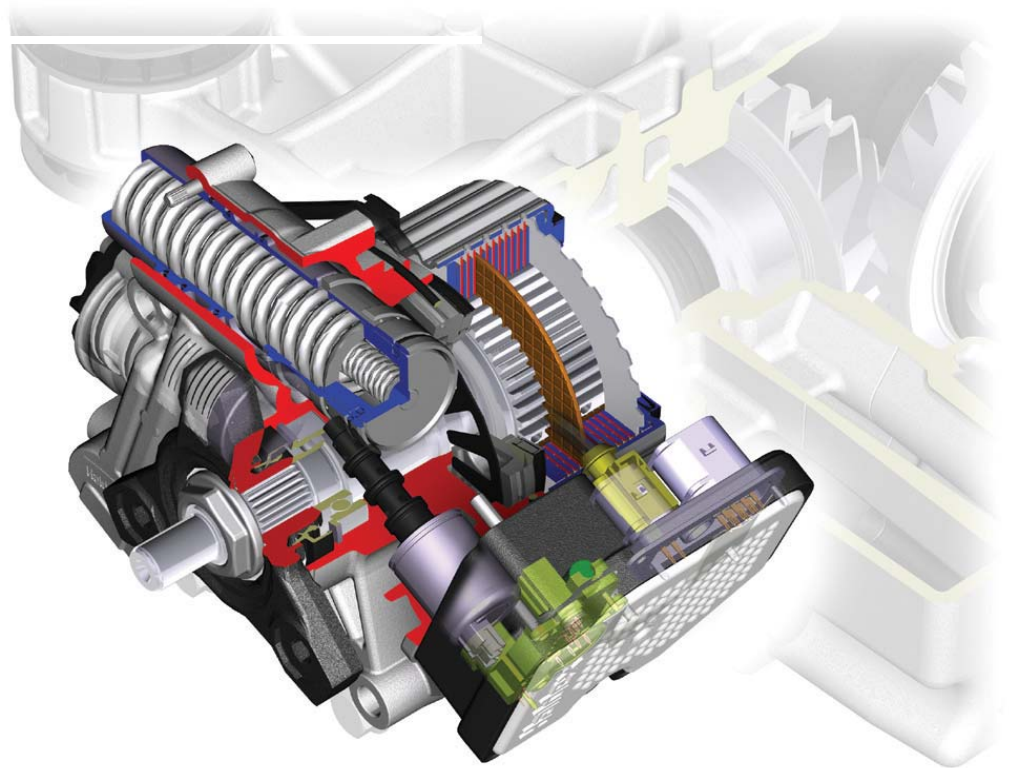

S414_005

Drivetrain

4MOTION Drivetrain System

The front wheels are conventionally driven by the front axle differential. At the same time, the torque is transferred to the propeller shaft by this differential through the angle transmission.

Depending on the degree of engagement of the all-wheel drive clutch, a torque that matches the driving situation is transmitted to the rear axle drive.

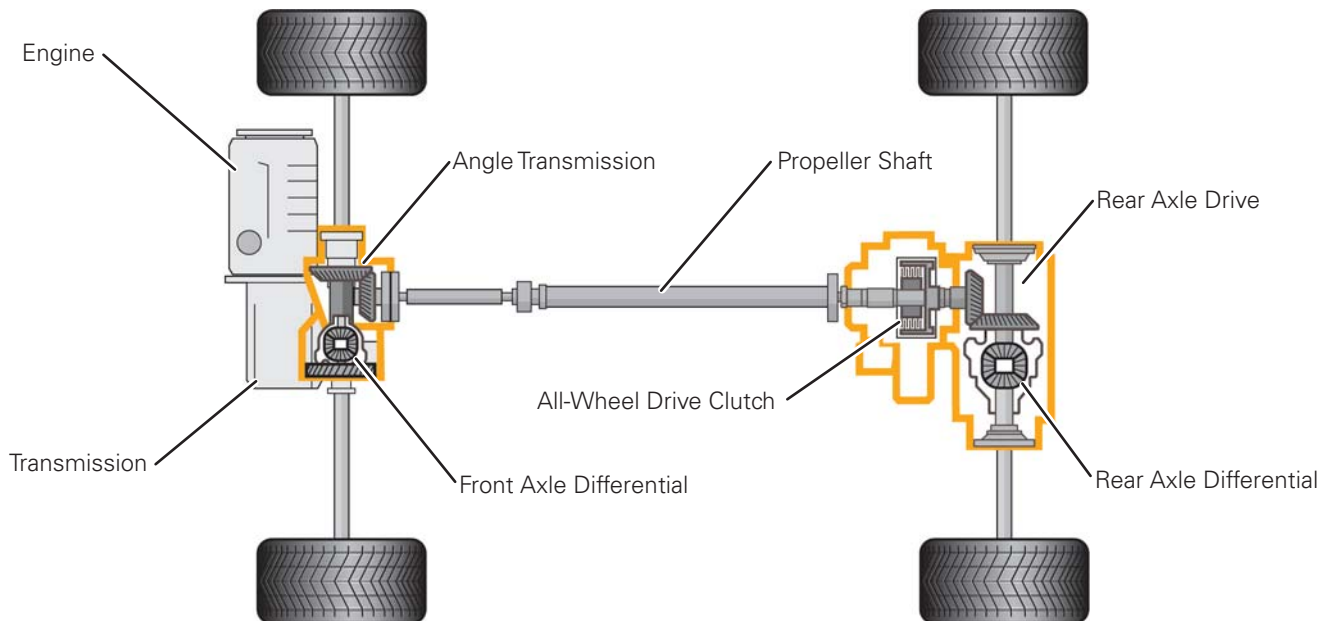

S414_007

Angle Transmission

The angle transmission increases the torque to the propeller shaft by a factor of 1.6. The diameter of the shaft can be smaller for this reason, since it transfers a smaller torque. In the rear axle drive, the torque is reduced again by the same factor of 1.6.

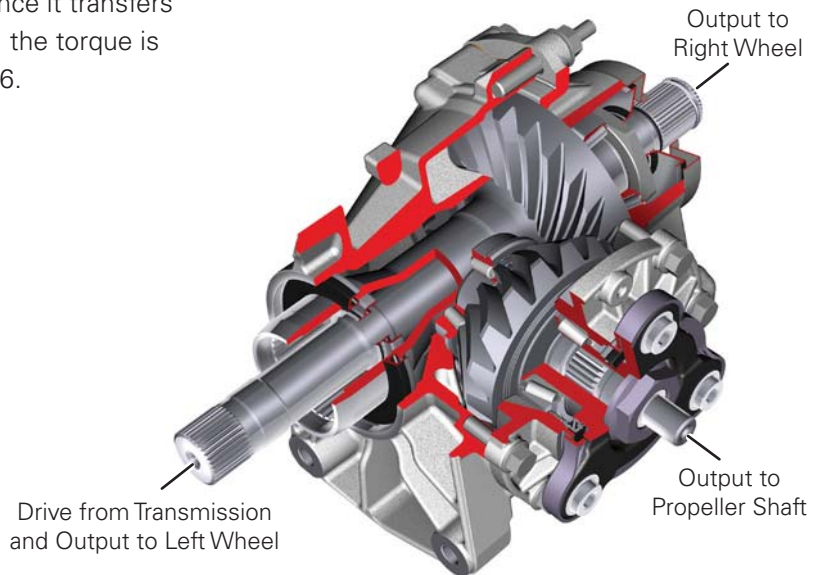

Power Flow

The force is transferred from the spur gear to the propeller shaft by the differential cage of the differential, the hollow shaft with crown wheel, and the pinion.

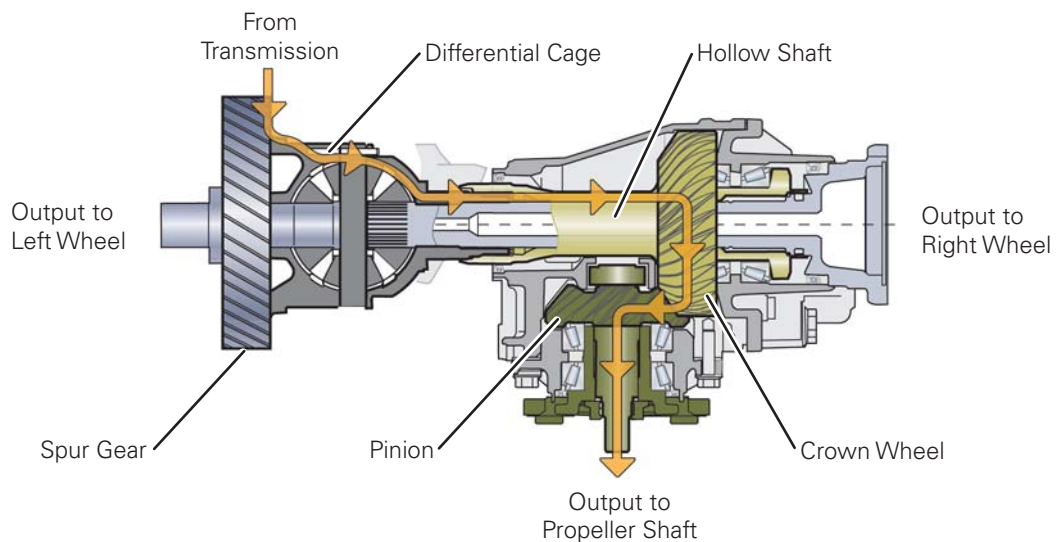

S414_008

S414_009

Drivetrain

Propeller Shaft

The propeller shaft has two parts. They are linked by a center joint. Flexible disk joints are used to make the connection to the transfer case and the all-wheel drive clutch. A rotational vibration absorber is permanently attached to the rear flexible disk joint and cannot be serviced separately. It reduces the transfer of engine vibrations through the rear axle differential to the body.

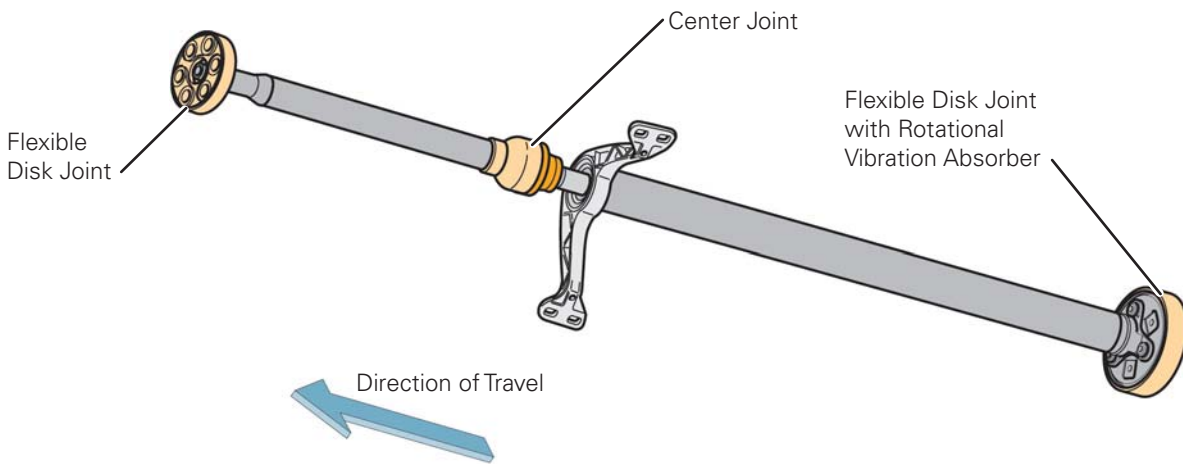

S414_010

Rear Flexible Disk Joint

The rear axle transmission and the propeller shaft are balanced during production. For this reason the drivetrain does not require balancing in the vehicle.

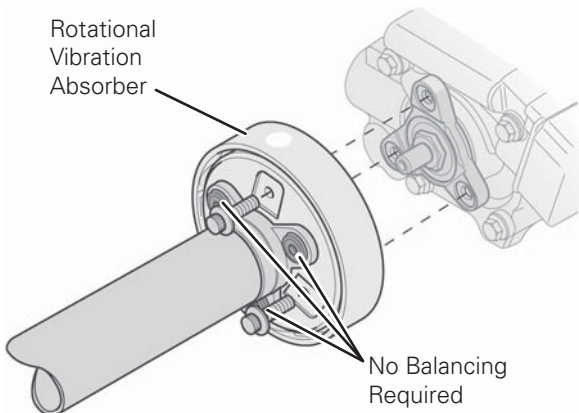

S414_011

Center Joint

The center joint is press-fitted and cannot be separated. This results in a compact and light design and the roll bellows is better protected.

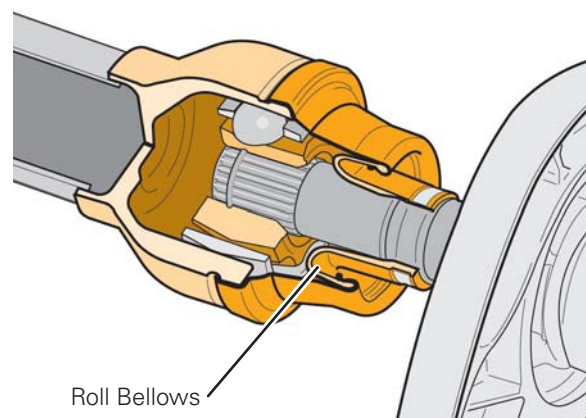

S414_012

Rear Axle Drive

The all-wheel drive clutch is integrated in the rear axle drive.

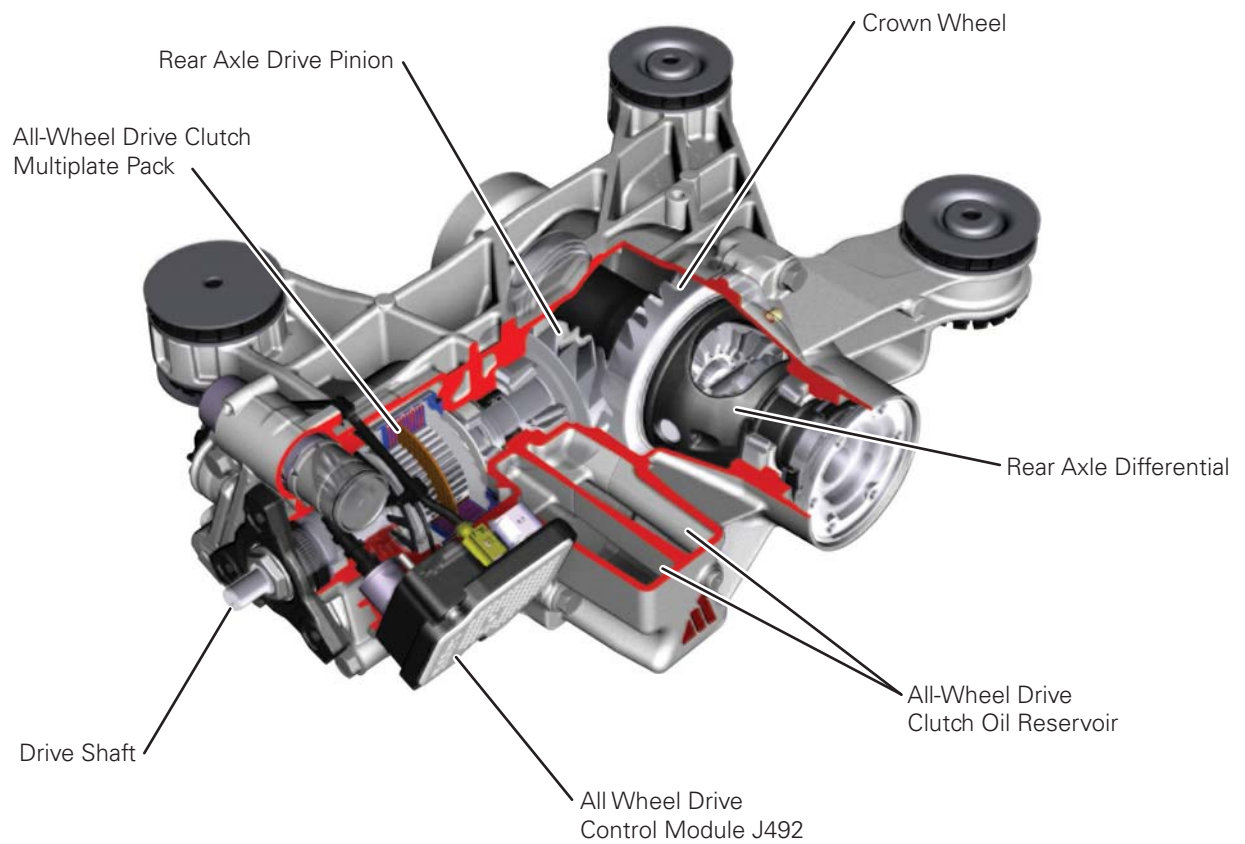

S414_013

Drivetrain

Function of the All-Wheel Drive Clutch

The all-wheel drive clutch between front and rear axle drives controls the drive torque to the rear axle. Depending on the degree of engagement, the all-wheel drive clutch directs the required drive torque to the rear axle.

All-Wheel Drive Clutch Components

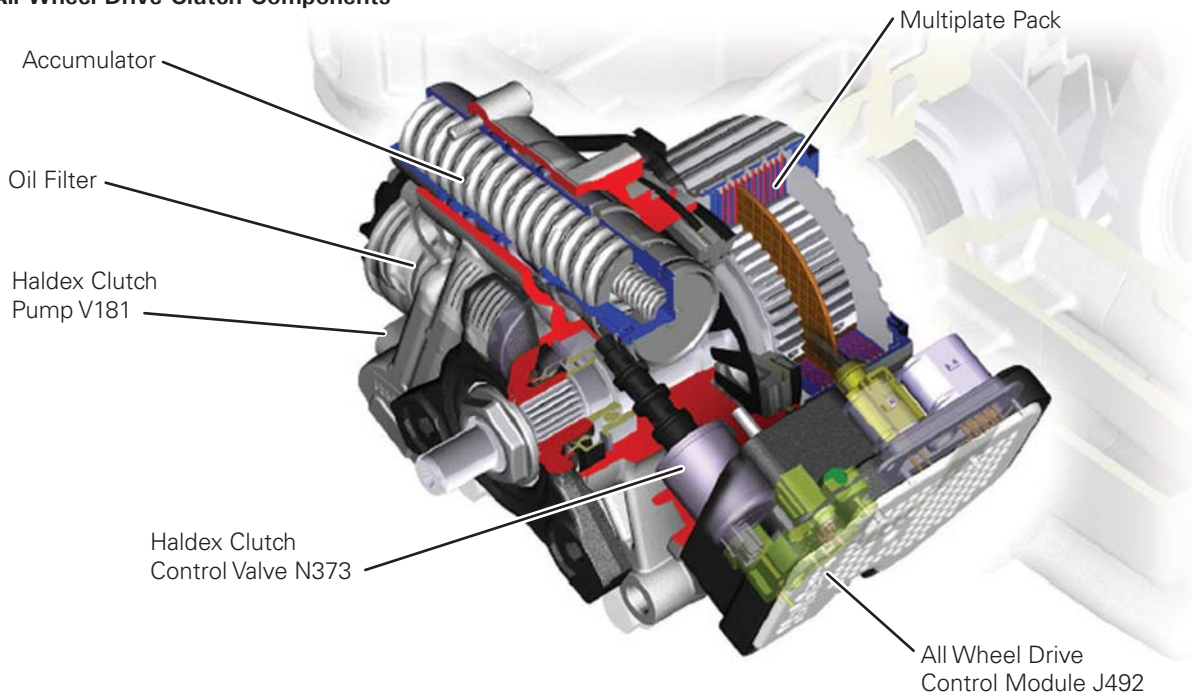

S 414_014

Oil Circuit Components

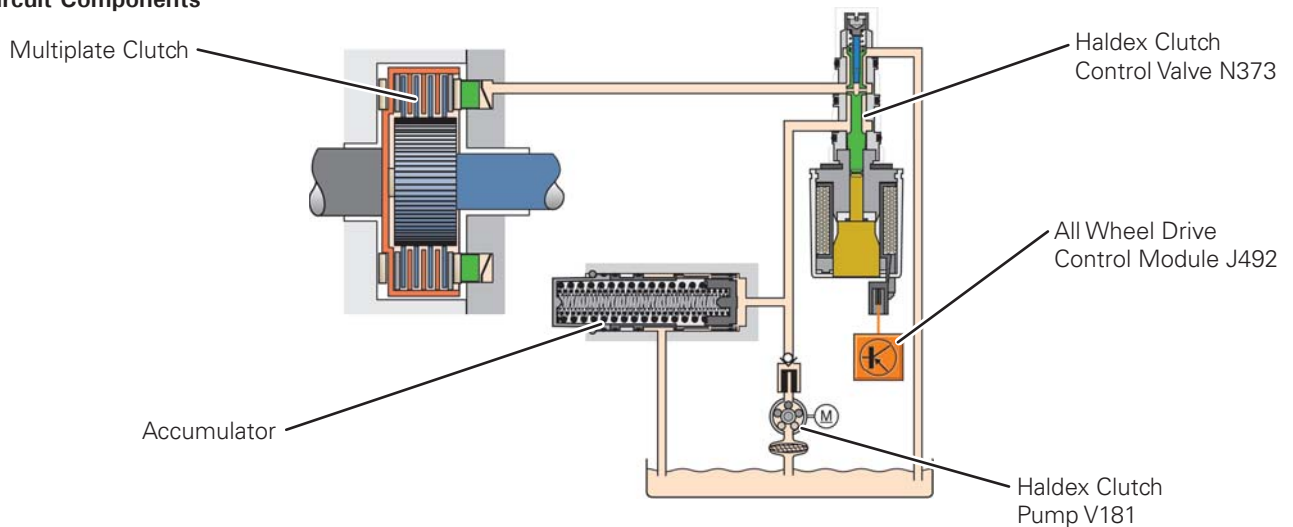

S414_064

All-Wheel Drive Clutch Details

Overview

The individual all-wheel drive clutch component groups are shown here to provide a better understanding of how they work.

Mechanical Assembly

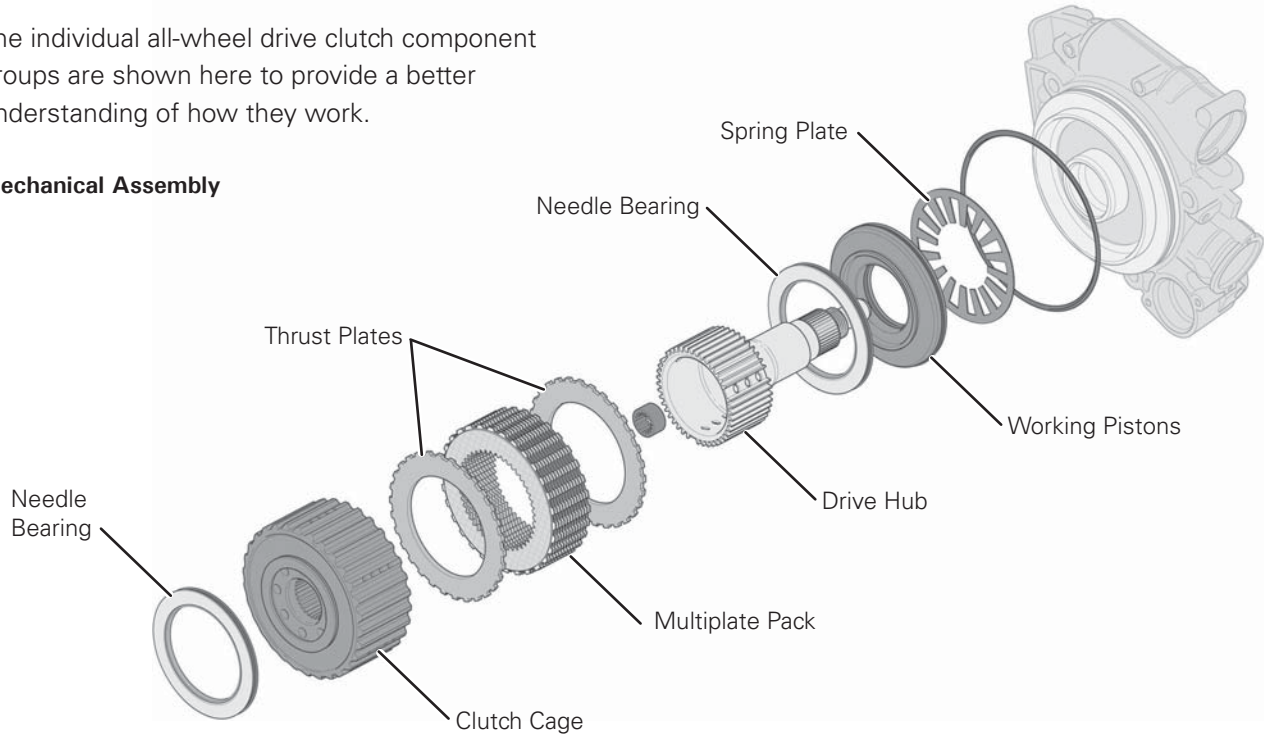

Electro-Hydraulic Assembly and All Wheel Drive Control Module J492

S414_015

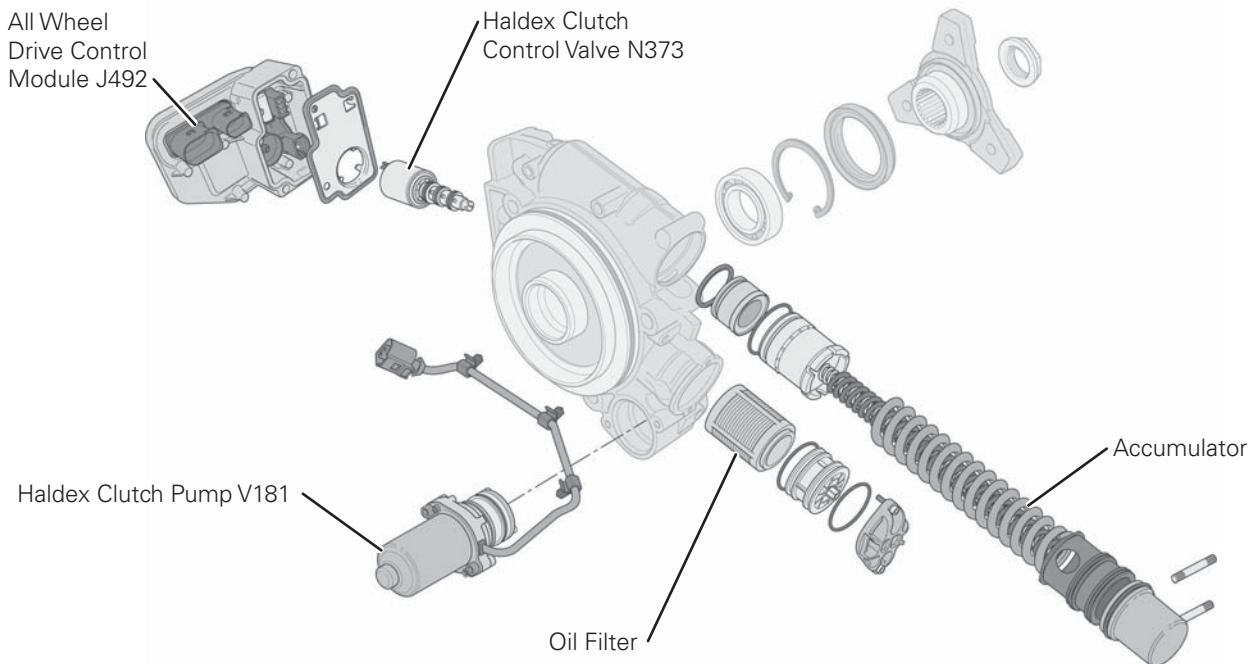

S414_040

All-Wheel Drive Clutch Details

Mechanical Assembly

The following sub-groups belong to the mechanical assembly:

- Multiplate clutch
- Working piston
- Spring plate

The entire assembly creates the frictional connection between front and rear axles. The multiplate pack is compressed when pressure is applied to the working piston. Depending on the contact pressure, a different torque (up to 1770 lbs-ft or 2400 Nm) can be transferred.

Multiplate Clutch

The multiplate clutch consists of the drive hub, the multiplate pack and the clutch cage.

Drive Hub

The drive hub is driven by the propeller shaft via the flange.

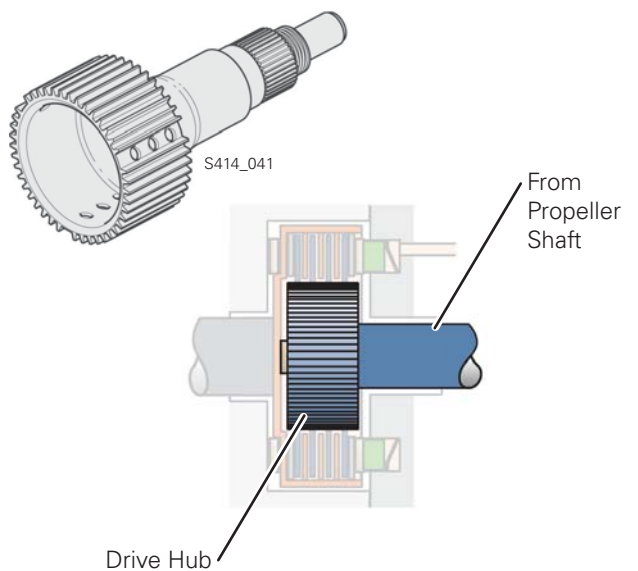

S414_051

Multiplate Pack

The multiplate pack consists of friction plates and steel plates, with one thrust plate in the front and one in the rear.

The friction plates have internal teeth that engage the drive hub. The steel plates engage the clutch cage with external teeth. The number of plates depends on the vehicle type.

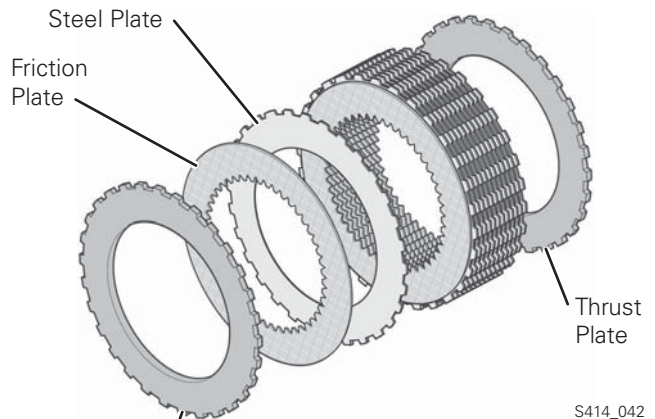

S414_042

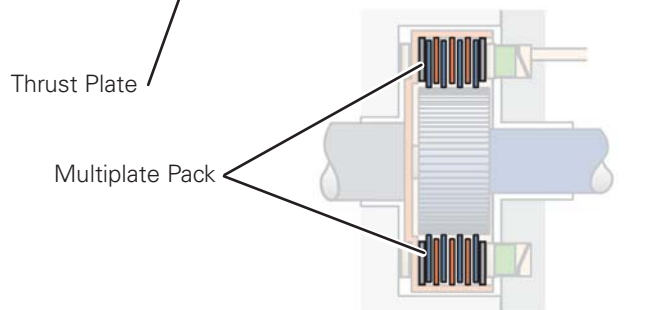

S414_052

All-Wheel Drive Clutch Details

Clutch Cage

The clutch cage is connected with the pinion of the rear axle by a spline, and transfers the drive torque to the rear axle.

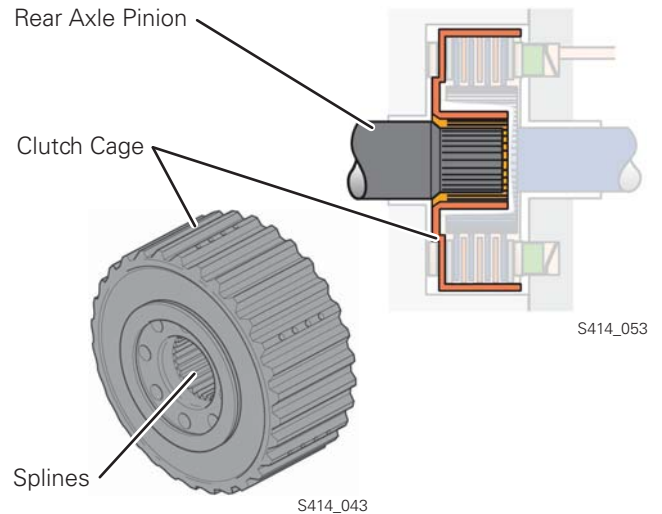

Working Piston

The working piston is a cylindrical piston.

Function

When actuating the clutch, the pressure of the working piston is transferred to the multiplate pack via a needle bearing. The working piston does not turn. The multiplate pack, on the other hand, rotates at drive speed.

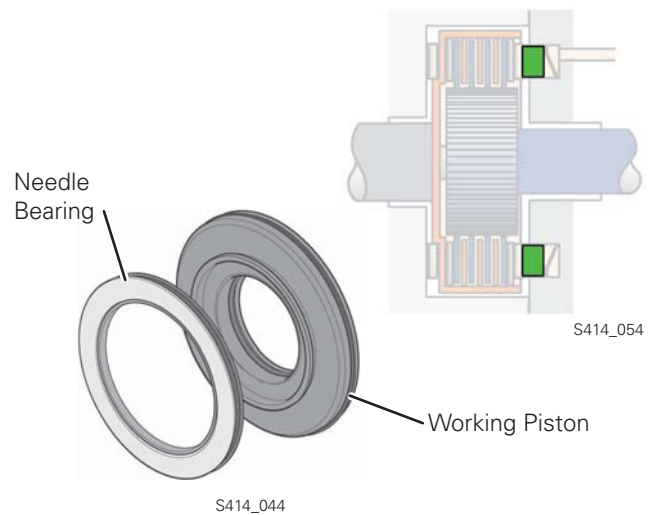

Spring Plate

The spring plate is located on the oil pressure side of the working piston.

Function

It creates a preload which pushes the working piston in place. This removes the play from the multiplate pack and the needle bearings.

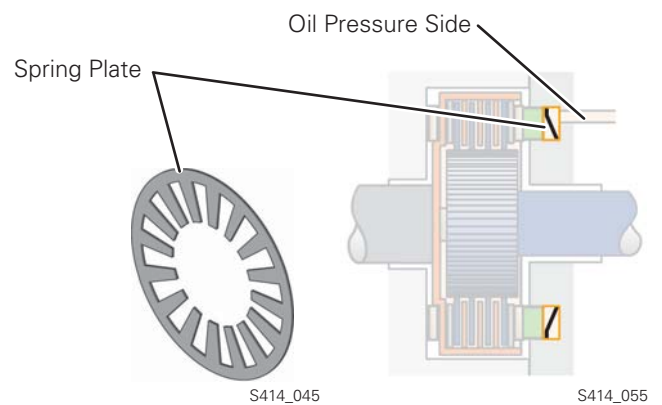

All-Wheel Drive Clutch Details

Electro-Hydraulic Assembly

The electro-hydraulic assembly consists of the Haldex Clutch Pump V181, the oil filter, the accumulator, and the Haldex Clutch Control Valve N373.

Haldex Clutch Pump V181

The Haldex Clutch Pump V181 is a reciprocating piston pump and is installed in the lower section of the all-wheel drive clutch. It generates the oil pressure. The accumulator in the oil circuit is filled regularly. It is requested by the All Wheel Drive Control Module J492 depending on the demand.

Function

The bores of the cylinder housing each contain a piston with a locating pin and a return spring. With the help of an angular ball bearing, the piston and locating pin are moved in stroke fashion when the cylinder housing turns so that oil is drawn in at the bottom and is discharged compressed at the top after 180 degrees of rotation.

Effects of Failure

When the Haldex Clutch Pump V181 fails, oil pressure cannot be generated. Torque is no longer transferred to the rear axle.

Oil Filter

The oil filter is a no-maintenance fleece filter. A check valve is integrated in the oil filter housing which prevents the oil pressure to the Haldex Clutch Pump V181 from dropping.

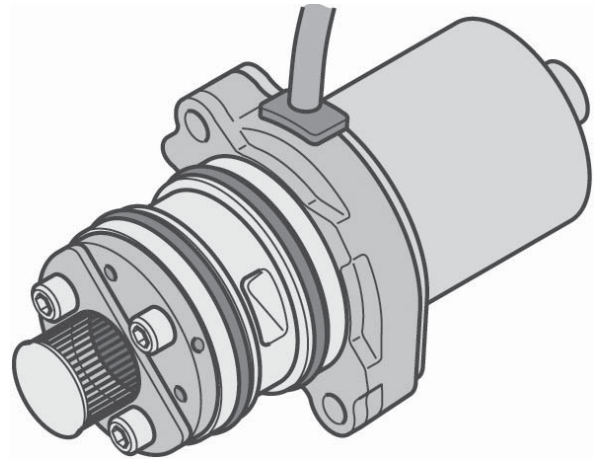

S414_046

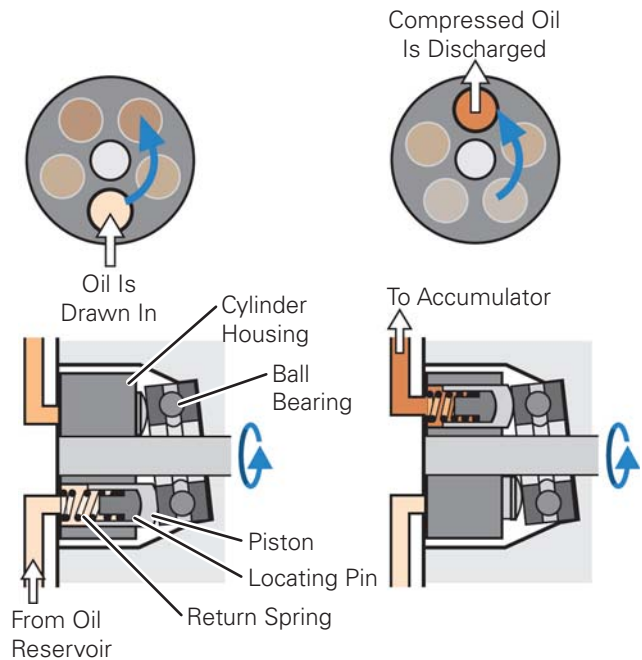

S414_022

All-Wheel Drive Clutch Details

Accumulator

The compact design of the accumulator includes three parallel acting springs and is positioned on top of the clutch. It adjusts the oil pressure using spring force and keeps it at 435 psi (30 bar).

System without Pressure:

The springs of the accumulator are relieved.

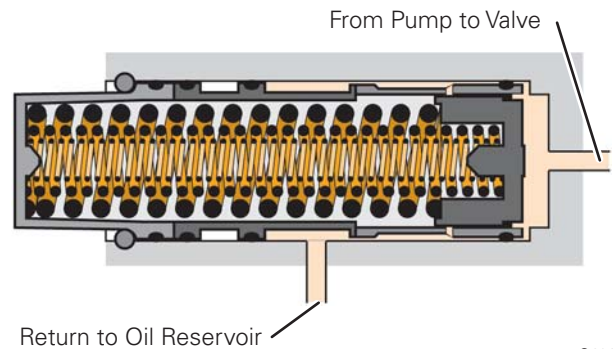

S414_016

System with Working Pressure:

The pressure chamber is filled by the pump. The pressure piston is pushed back and the spring is under tension.

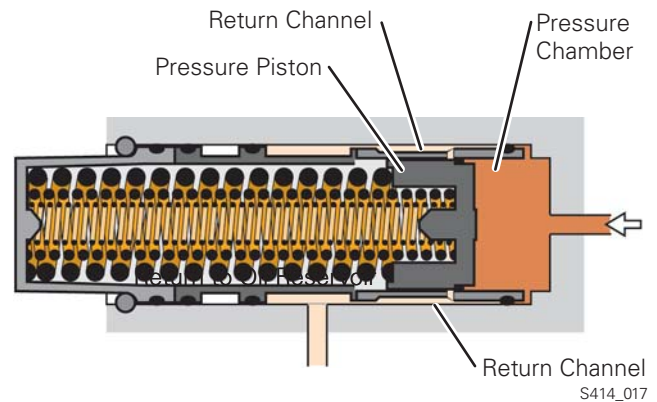

S414_017

If the oil pressure exceeds 435 psi (30 bar), the return channels become accessible, the pressure in the direction of the oil reservoir is reduced, and oil returns to the reservoir.

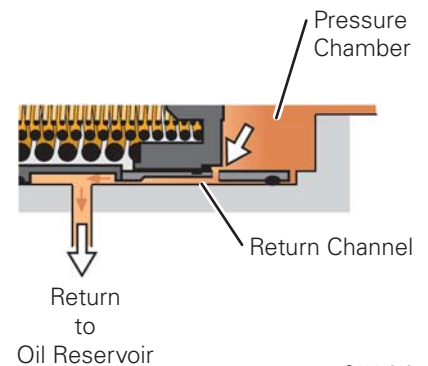

S414_018

All-Wheel Drive Clutch Details

Haldex Clutch Control Valve N373

Task

The Haldex Clutch Control Valve N373 controls the working pressure that is passed on to the working pistons. Pressure increases in proportion to the electric current applied to the solenoid. Pressure is precisely defined for each current value.

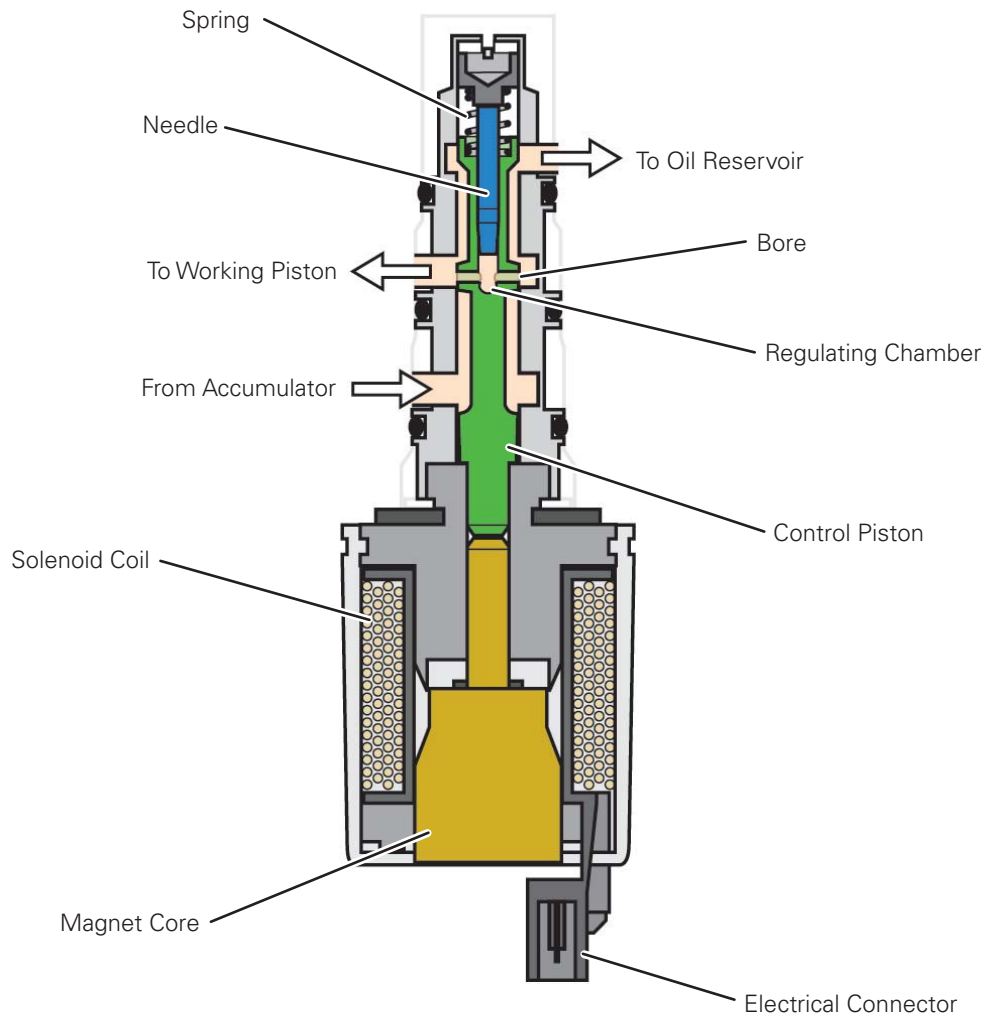

All-Wheel Drive Clutch Details

Function

The Haldex Clutch Pump V181 and the accumulator have built a pressure of 435 psi (30 bar). (1)

Applying an electrical current to the solenoid coil generates a magnetic force the amount of which depends on the current applied. This moves the control piston up, opens the flow, and the working pressure is generated. (2)

When the desired working pressure has been reached, the balance of force described below is established so that the flow is closed and the working pressure maintained. (3)

The working pressure is applied to the working piston and in the control piston regulating chamber. The pressure in the regulating chamber works in the same direction as the return force of the spring and supports it as counteracting force to the magnetic force. A balance of force is achieved.

When the full current is applied, the intake on the bottom remains open and the entire oil pressure generated by Haldex Clutch Pump V181 is used as working pressure.

If the clutch has to be opened, no more current will be applied to the solenoid coil, the control piston returns to its original position, and the pressure is relieved by routing oil to the oil reservoir.

Effects of Failure

If the Haldex Clutch Control Valve N373 fails, the all-wheel function is no longer available.

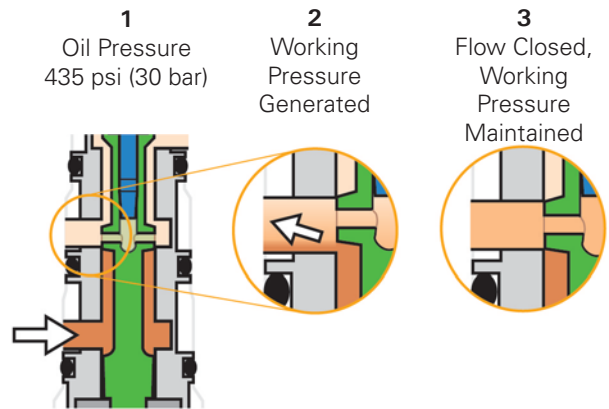

S414_020

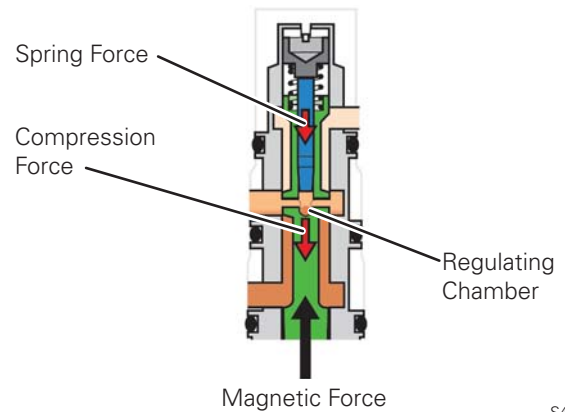

S414_021

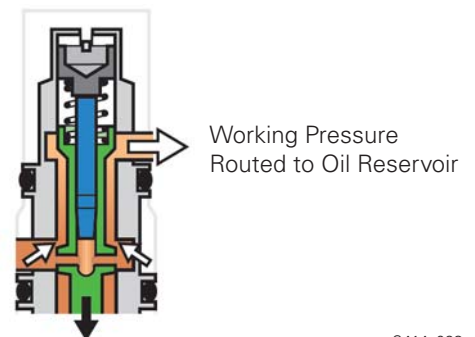

S414_023

All-Wheel Drive Clutch Details

All Wheel Drive Control Module J492

Task

All Wheel Drive Control Module J492 regulates the pump operating times and Haldex Clutch Control Valve N373. The amount of pressure is solely determined by the valve position. A temperature sensor is located on the printed circuit board of All Wheel Drive Control Module J492 where its measured values indicate the oil temperature.

All Wheel Drive Control Module J492 is integrated in the CAN data bus drive. This allows precise control of the system with only one sensor. Based on data on the driving situation, the All Wheel Drive Control Module J492 determines the desired pressure so that the amount of all-wheel drive clutch engagement and transfer are adjusted to the situation.

In case of ESP or ABS intervention, ABS Control Module J104 determines the amount of all-wheel drive clutch engagement via All Wheel Drive Control Module J492.

Effects of Failure

Because Haldex Clutch Control Valve N373 can no longer be selected, no more working pressure is generated. The clutch is disengaged and the rear axle is no longer driven.

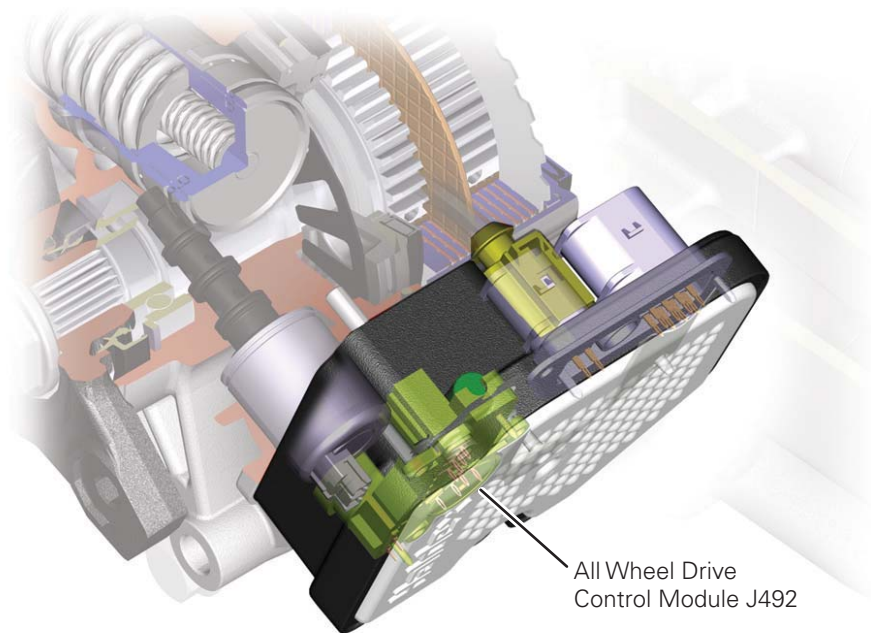

Oil Circuit

The electro-hydraulic components build up the oil pressure, controlling the contact pressure on the multiplate clutch.

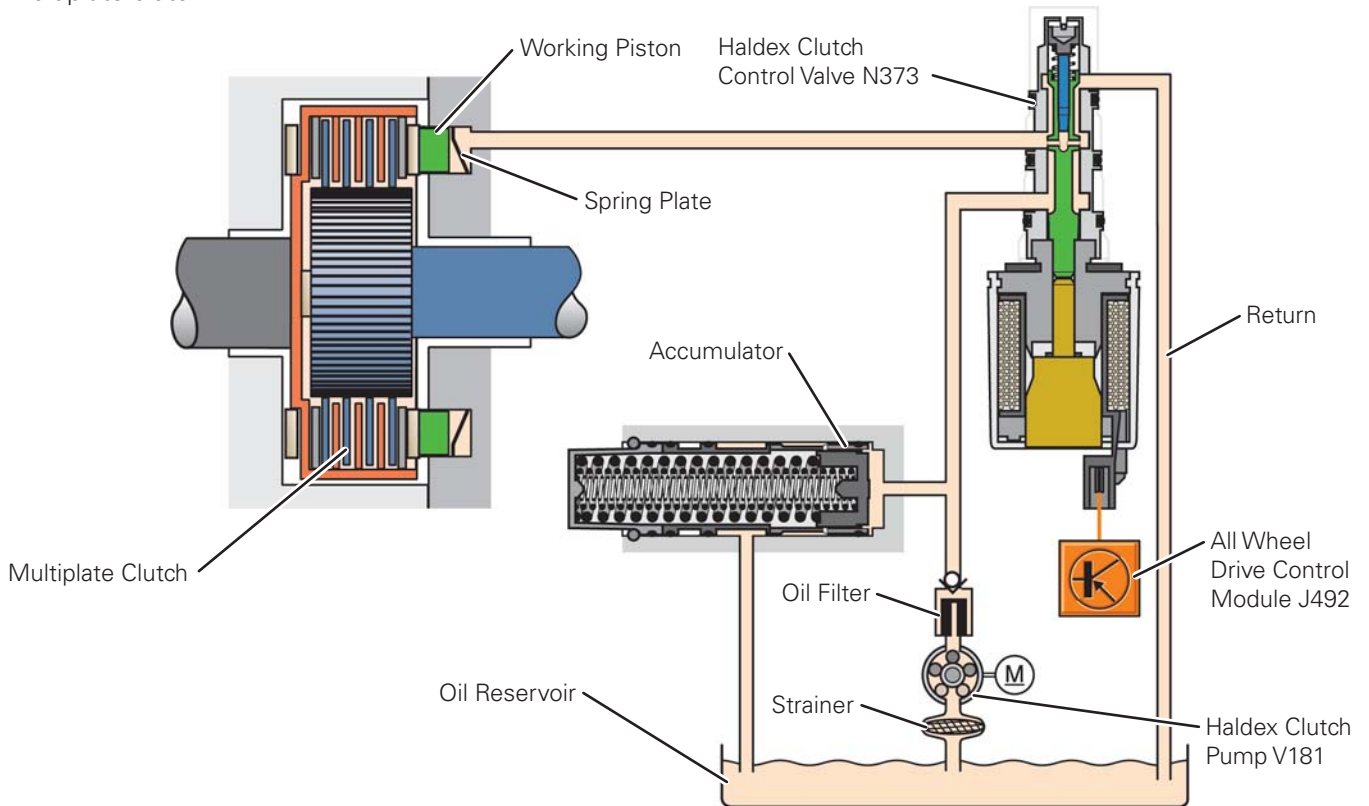

S414_027

System Without Pressure

The illustration shows the system in the depressurized state. As long as the engine is off and only the ignition is turned on, All Wheel Drive Control Module J492 is selected but no pressure is generated.

The Haldex Clutch Control Valve N373 is opened without current.



Because a small amount of pressure is applied through the spring plate, a speed of 31 mph (50 km/h) and a distance of 31 miles (50 km) may not be exceeded when towing with one axle raised.

A Pressureless System Is Needed in These Situations

Towing

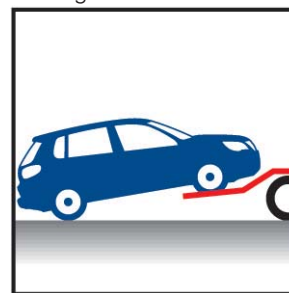

S414_030

Roll Dynamometer

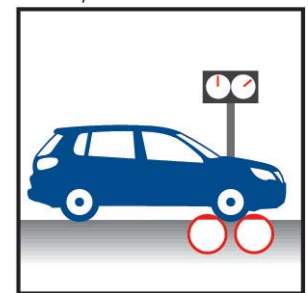

S414_031

Controls

Pressure Buildup at Engine Start

When the engine is started, Haldex Clutch Pump V181 is activated. Haldex Clutch Pump V181 is selected as soon as an engine speed of 400 rpm is reached. It delivers oil via the filter to the accumulator until a pressure of 435 psi (30 bar) is reached in the oil circuit. Haldex Clutch Control Valve N373 is closed by All Wheel Drive Control Module J492 so that the working pressure is passed on to the working piston and the multiplate pack is compressed.

Starting

When starting to drive and when accelerating, the entire rear axle drive torque is immediately available.

Driving

In each driving situation, the pressure between pump and valve is kept constant at 435 psi (30 bar)

through the accumulator. The working pressure is solely controlled through Haldex Clutch Control Valve N373, which can adjust the contact pressure on the working piston according to the demand.

This working pressure may lie between 0%, such as when braking, and 100%, as when accelerating.

Controlled Working Pressure

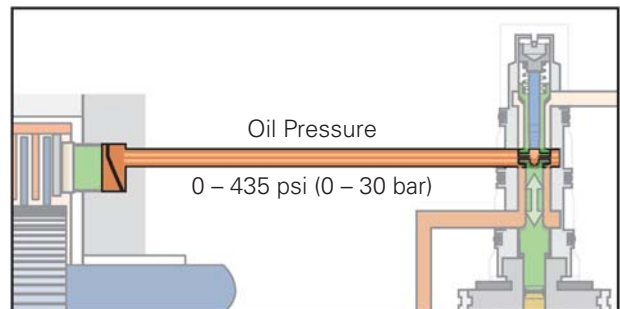

S414_029

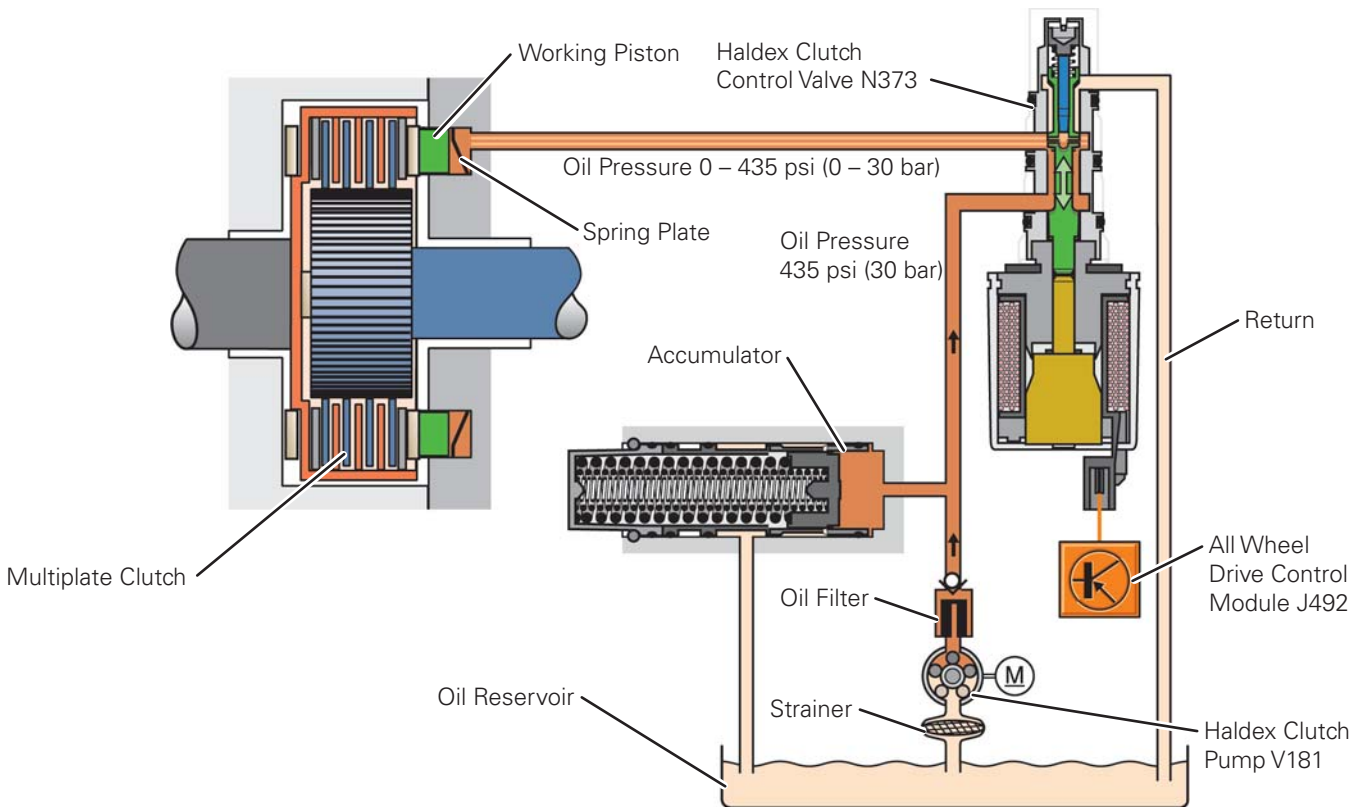

S414_028

Driving Scenarios

Starting or Accelerating

A high drive torque is required at the rear axle. The valve closes completely and the contact pressure can reach its maximum.

Drive Torque at the Rear Axle

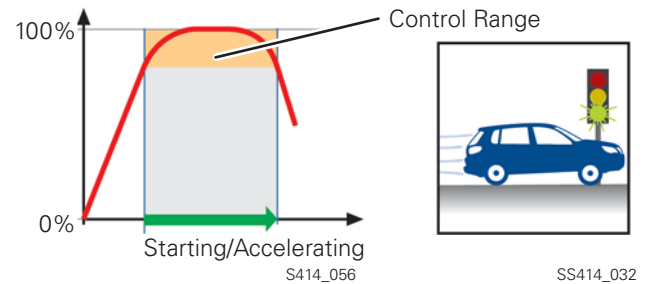

Fast Driving

Only a low torque is required at the rear axle. The contact pressure is controlled according to demand (control range).

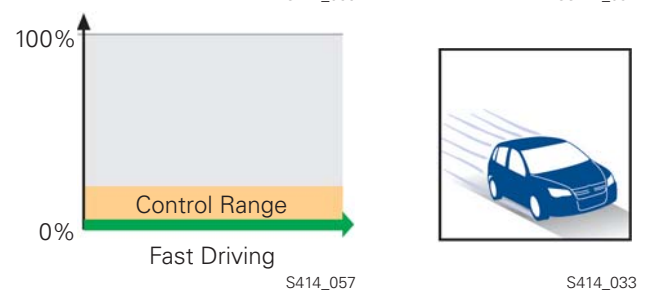

Braking

No torque is transferred to the rear axle when braking. The valve is opened and the pressure on the working piston is reduced. The clutch is disengaged.

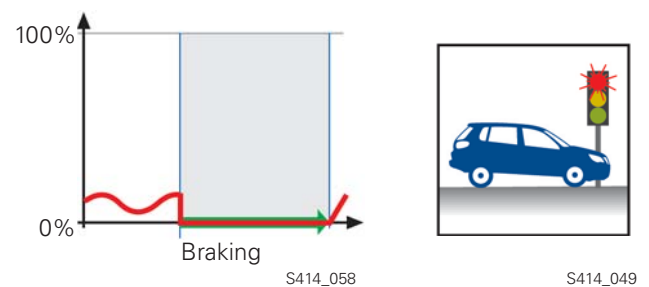

Stopping

The clutch is disengaged as long as the vehicle is being braked. When the vehicle is stopped, the pre-control uses the signal from the accelerator position. When starting to drive, the pressure is built up again and full torque capacity is available.

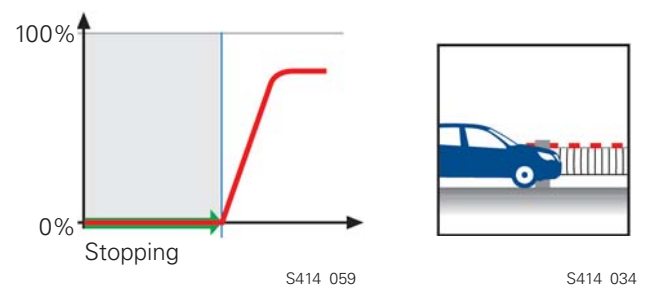

Parking Maneuvers

Only a low torque is transferred during parking maneuvers. The drivetrain is not under tension. The clutch is controlled according to demand (control range).

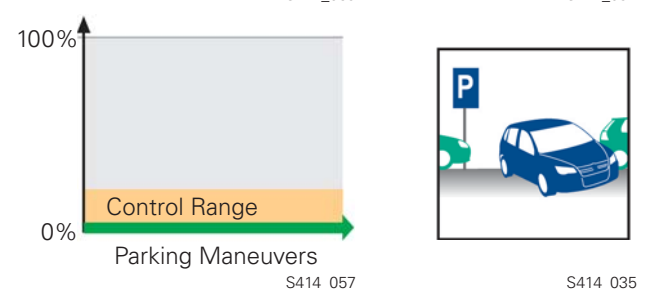

Controls

Critical Driving Situations

Driving on Slippery Roads

The working pressure is controlled according to demand.

Signals come from ABS Control Module J104, which detects slippage through the speed sensors and calculates the required traction.

ESP or ABS Intervention

When a wheel slip control system is activated, the amount of clutch engagement is controlled indirectly through the ABS Control Module J104. For example, the clutch may be disengaged entirely for an ABS intervention while it can be engaged for an ESP intervention.

Drive Torque at the Rear Axle

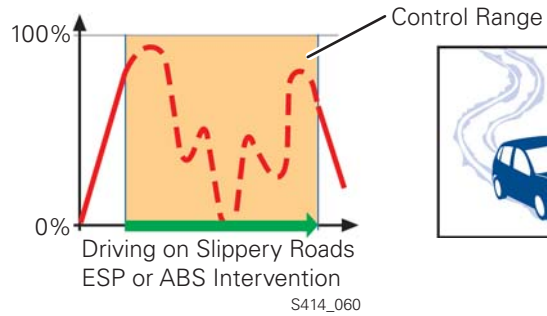

S414_036

Starting with Slip (On Ice or Snow)

The all-wheel clutch is engaged when both wheels of the front axle spin. The rear axle takes on all of the drive force.

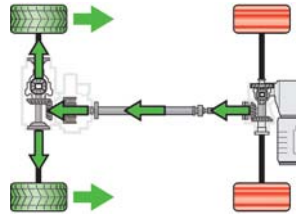

S414_065



S414_038

If only one wheel of the front axle spins, the Electronic Differential Lock (EDL) becomes active. The spinning wheel is braked and the drive force of the other wheel is increased. At the same time the all-wheel drive clutch is engaged and a large portion of the drive force is transferred to the rear axle.

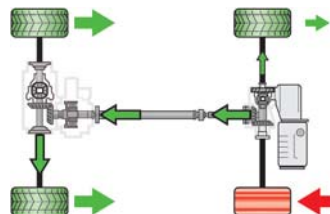

S414_062

System Overview

Sensors

Engine Speed (RPM) Sensor G28

Throttle Position (TP) Sensor G79

ABS Wheel Speed SensorS G44-G47

Brake Light Switch F

Electro-Mechanical Parking Brake Control Module J540

Data Bus On Board Diagnostic Interface J533

Steering Angle Sensor G85

Engine Control Module (ECM) J623



Drive CAN Data Bus

ABS Control Module J104

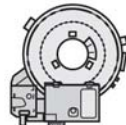

Actuators

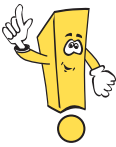
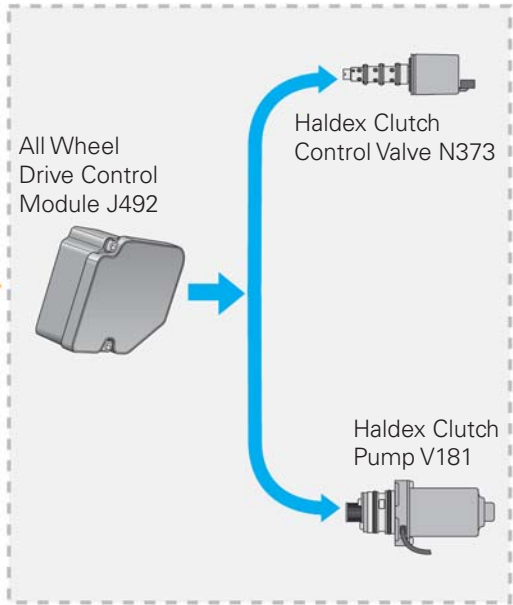

A sensor cluster is integrated in Electro-Mechanical Parking Brake Control Module J540. It contains the sensors for lateral acceleration, longitudinal acceleration, and yaw rate.

S414_026

Controls

Functional Diagram

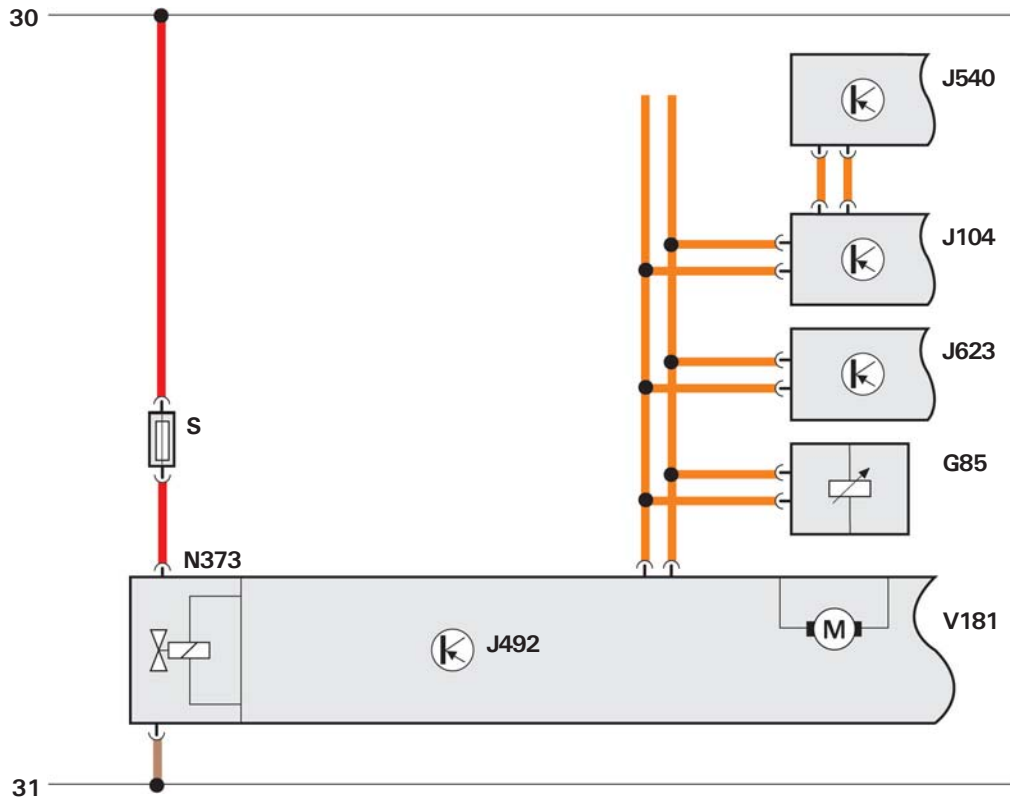

- G85 Steering Angle Sensor
- J104 ABS Control Module
- J492 All Wheel Drive Control Module
- J540 Electro-Mechanical Parking Brake Control Module
- J623 Engine Control Module
- N373 Haldex Clutch Control Valve
- S Fuse
- V181 Haldex Clutch Pump

Color Coding

- █ Positive
- █ Ground
- ▬▬▬ CAN Data Bus Line

Testing Individual Components

Individual component tests can be called through function and component selections in Guided Fault Finding.

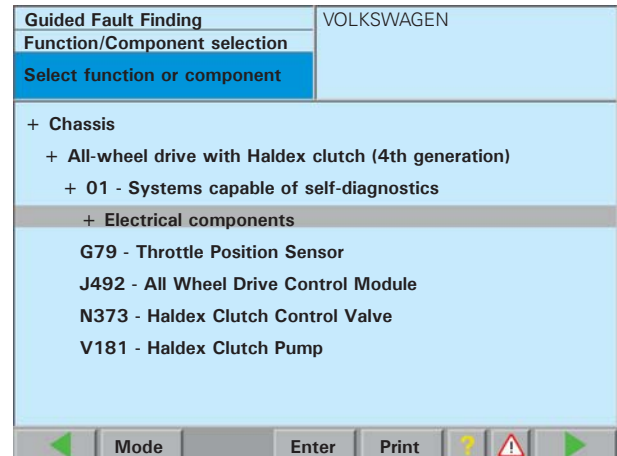

S414_069

All Wheel Drive Control Module J492 Self-Diagnostics

All Wheel Drive Control Module J492 has the **address word 22** for self-diagnostics.

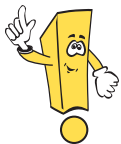

The all-wheel drive clutch can be replaced separately.

Elaborate adjustment activities after replacement are no longer necessary because the pinion is part of the rear axle transmission and is not replaced.

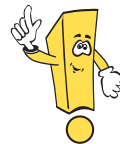

High-performance oil was developed especially for the requirements of the generation VI all-wheel drive clutch.

Notes

Knowledge Assessment

An on-line Knowledge Assessment (exam) is available for this Self-Study Program.

The Knowledge Assessment may or may not be required for Certification.

You can find this Knowledge Assessment at:

www.vwwebservice.com

For Assistance, please call:

Volkswagen Academy

Certification Program Headquarters

1 – 877 – 791 – 4838

(8:00 a.m. to 8:00 p.m. EST)

Or, E-Mail:

concierge@volkswagenacademy.com



Volkswagen of America, Inc.
3800 Hamlin Road
Auburn Hill, MI 48326
Printed in the U.S.A.
January 2008

