

THE RETROFITTABLE HYDRAULIC CLUTCH SYSTEM

**ROBUST
EASY TO MOUNT
EXCELLENT MODULATION
LESS MAINTENANCE**



MAGURA HYMEC



MAGURA.COM

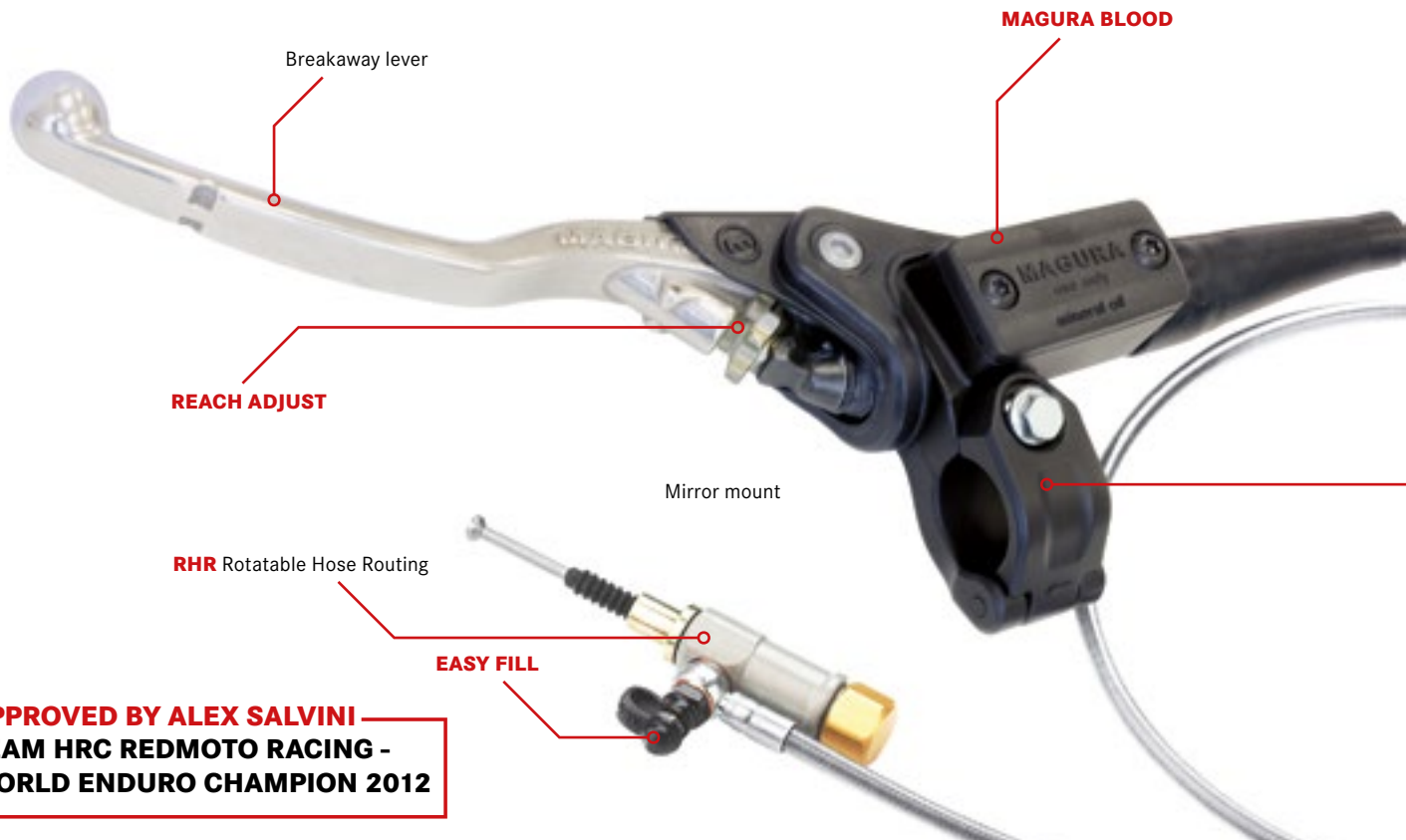

MAKE / MODEL	YEAR	ORDER CODE	LINE LENGTH	PISTON-Ø	ASSEMBLY	SLAVE NO.	MASTER	PRESSURE LINE
AJP PR5	09 →	2100006**	1120 mm	9,5 mm	65	0120651	2700183	0722137
HONDA								
CRF 150	08 → 14	2100004	1045 mm	9,5 mm	70	2100003	2700183	0722138
CR 250 R	90 → 03	2100019	1045 mm	9,5 mm	52	0120648*	2700183	0722138
CR 250 R	04 → 06	2100007**	1045 mm	9,5 mm	44	0120649*	2700183	0722138
CRF 250 R	04 → 09	2100009	1045 mm	9,5 mm	57	0120655	2700183	0722138
CRF 250 R	10 → 13	2100005	1045 mm	9,5 mm	57	0120655	2700183	0722138
CRF 250 R	14 → 15	2100307	1045 mm	9,5 mm	32 (H+)	2100308*	2700183	0722138
CRF 450 R	04 → 08	2100010	1045 mm	9,5 mm	41 (H+)	0120649*	2700183	0722138
CRF 450 R	09 → 12	2100005	1045 mm	9,5 mm	57	0120655	2700183	0722138
CRF 450 R	13 → 14	2100030	1045 mm	10,5 mm	59	0120652	2700186	0722138
CRF 450 R	2015	2100363	1045 mm	9,5 mm	32 (H+)	2100308*	2700183	0722138
KX 500 R	84 → 03	2100019	1045 mm	9,5 mm	52	0120648*	2700183	0722138
KAWASAKI								
KX 250	90 → 98	2100004**	1045 mm	9,5 mm	70	2100003	2700183	0722138
KX 250 F	04 → 08	2100019**	1045 mm	9,5 mm	52	0120648*	2700183	0722138
KX 250 F	09 → 15	2100006	1120 mm	9,5 mm	65	0120651	2700183	0722137
KX 450 F	09 → 14	2100007	1045 mm	9,5 mm	44 (H+)	0120649*	2700183	0722138
KX 450 F	2015	2100364	1045 mm	9,5 mm	47 (H+)	0120648*	2700183	0722138
KX 500	90 → 03	2100004**	1045 mm	9,5 mm	70	2100003	2700183	0722138
KTM								
250 SX 300/360	90 → 94	2100019	1045 mm	9,5 mm	52	0120648*	2700183	0722138
SUZUKI								
RM 250	97 → 03	2100019	1045 mm	9,5 mm	52	0120648*	2700183	0722138
RM-Z 250	04 → 05	2100019	1045 mm	9,5 mm	52	0120648*	2700183	0722138
RM-Z 250	2009	2100011	1045 mm	9,5 mm	44 (H+)	0120649*	2700183	0722138
RM-Z 250	10 → 15	2100302	1045 mm	9,5 mm	57 (H+)	0120655*	2700183	0722138
RM-Z 450	09 → 15	2100012	1045 mm	9,5 mm	44 (H+)	0120649*	2700183	0722138
YAMAHA								
YZ 250	88 → 98	2100004**	1045 mm	9,5 mm	70	2100003	2700183	0722138
YZ 250	99 → 03	2100019	1045 mm	9,5 mm	52	0120648*	2700183	0722138
YZ 250 F	09 → 13	2100008	1120 mm	9,5 mm	59	0120652	2700183	0722137
YZ 250 F	14 → 15	2100302	1045 mm	9,5 mm	57	0120655	2700183	0722138
YZ 450 F	03 → 05	2100019**	1045 mm	9,5 mm	52	0120648*	2700183	0722138
YZ 450 F	09 → 15	2100008	1120 mm	9,5 mm	59	0120652	2700183	0722137

* Spare Part Slave Cylinder = Spare slave cylinders since 2012 are equipped with standard cap and bracket - please ensure when ordering to check if cap and bracket are also required

** Extra Parts are required to fit this Hymec kit to this motorcycle - check separate table on page 17

H+ Slave attached from rear cap with stud 0430998

Carbon tubing

167 HYMEC | OFF-ROAD

MAGURA HYMEC – An easy to install alternative to a mechanical clutch. This system replaces the clutch lever and cable – with a small lightweight hydraulic system for improved clutch control. The HYMEC ensures an easier operating pressure, a constant pressure point, no more cable adjustment and smooth clutch actuation to ensure the perfect take-off every time.

Clutch operation with the MAGURA hydraulic kick. The thousand-fold proven hydraulic clutch operating system for Motocross and Enduro. Superior technology which unites an abundance of unique advantages into one: No fading, superfine modulation, almost maintenance-free, automatic compensation for clutch wear and up to 20% less actuating force! HYMEC provides a uniquely sensitive operation and significantly improves vehicle control. A weight saving of up to 150 grams is possible according to the model.

** EXTRA PARTS ADDITIONALLY REQUIRED!

MAKE / MODEL	YEAR	HYMEC-NO.	ORDER CODE	ORDER CODE	ORDER CODE
CR 250 R	04 → 06	2100007	0430987	0488255	
KX 250	90 → 98	2100004	0412310	0451530 (x3)	
KX 250 F	04 → 08	2100019	0430240	0723189	0412310
KX 500	90 → 03	2100004	0412310	0451530 (x3)	+
PR 5	09 → 15	2100006	0723115	2700177	
RM-Z 250	04 → 05	2100019	0430240	0723189	0412310
YZ 250	88 → 98	2100004	0412310	0451530 (x3)	
YZ 450 F	03 → 05	2100019	0430240	0723189	0412310

EASY MOUNT

MAKE / MODEL	ORDER CODE	REAR CAP	BRACKET	PISTON KIT	CLAMP	LEVER	NEW
AJP PR5	2100006	0430217	0430224	0723184	2700177	0723290	
HONDA							
CRF 150	2100004	0430217	0430224	0723184	2700176	0723290	
CR 250 R	2100019	0430217	0430987	0723184	2700176	0723290	
CR 250 R	2100007**	0430998	0431002	0723184	2700176	0723290	
CRF 250 R	2100009	0430217	0430224	0723184	2700176	0723290	
CRF 250 R	2100005	0430217	0430224	0723184	2700176	0723290	
CRF 250 R	2100307	0430998	2401084	0723184	2700176	0723290	
CRF 450 R	2100010	0430998	0431001	0723184	2700176	0723290	
CRF 450 R	2100005	0430217	0430224	2700184	2700185	0723290	
CRF 450 R	2100030	0430217	0430224	0723185	2700176	0723290	
CRF 450 R	2100363	0430998	2401330	0723184	2700176	0723290	NEW
CR 500 R	2100019	0430217	0430987	0723184	2700176	0723290	
KAWASAKI							
KX 250	2100004**	0430217	0430224	0723184	2700176	0723290	
KX 250 F	2100019**	0430217	0430987	0723184	2700176	0723290	
KX 250 F	2100006	0430998	0431002	0723184	2700176	0723290	
KX 450 F	2100007	0430217	0430224	0723184	2700176	0723290	
KX 450 F	2100364	0430998	2401327	0723184	2700176	0723290	NEW
KX 500	2100004**	0430217	0430224	0723184	2700176	0723290	
KTM							
250 SX 300/360	2100019	0430217	0430987	0723184	2700176	0723290	
SUZUKI							
RM 250	2100019	0430217	0430987	0723184	2700176	0723290	
RM-Z 250	2100019	0430217	0430987	0723184	2700176	0723290	
RM-Z 250	2100011	0430998	0430990	0723184	2700176	0723290	
RM-Z 250	2100302	0430998	0430990	0723184	2700176	0723290	
RM-Z 450	2100012	0430998	0430991	0723184	2700176	0723290	
YAMAHA							
YZ 250	2100004**	0430217	0430224	0723184	2700176	0723290	
YZ 250	2100019	0430217	0430987	0723184	2700176	0723290	
YZ 250 F	2100008	0430217	0430224	0723184	2700176	0723290	
YZ 250 F	2100302	0430217	0430224	0723184	2700176	0723290	
YZ 450 F	2100019**	0430217	0430987	0723184	2700176	0723290	
YZ 450 F	2100008	0430217	0430224	0723184	2700176	0723290	

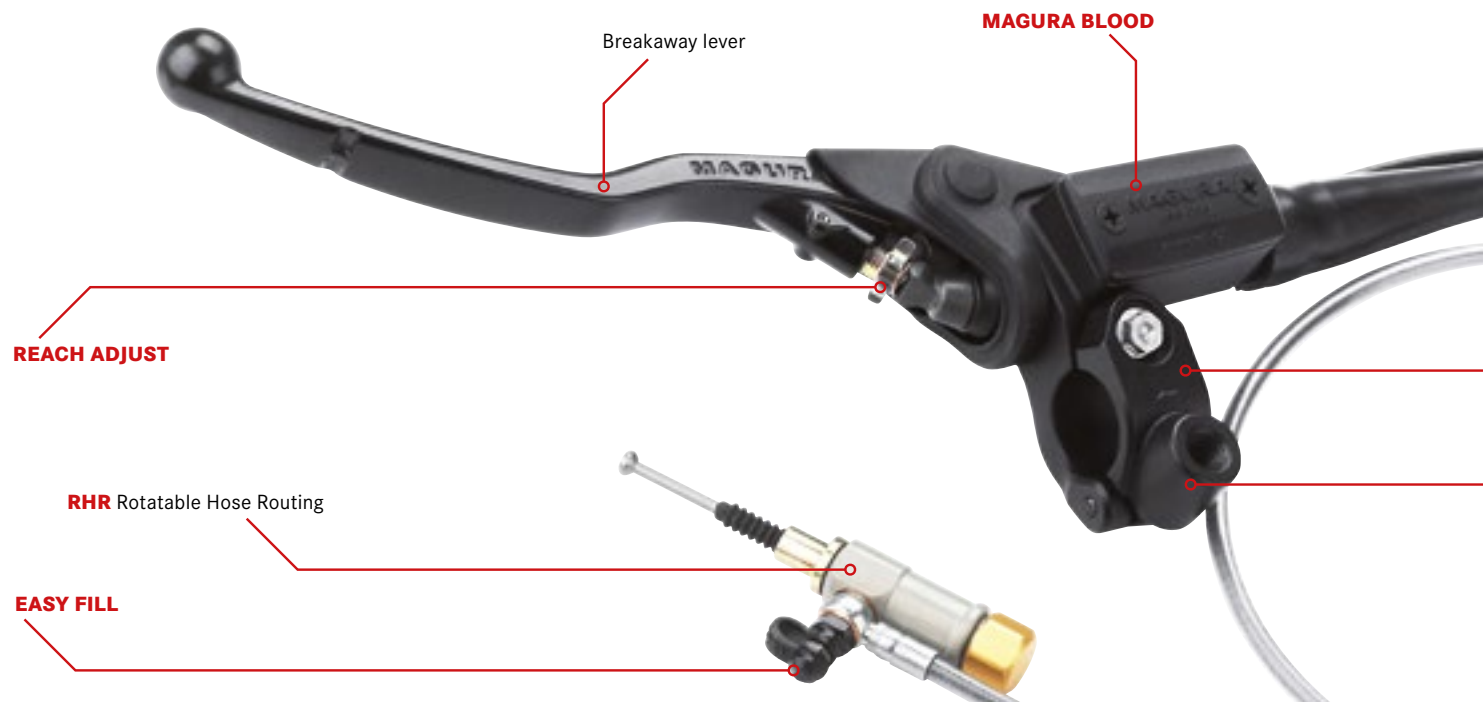

MAKE / MODEL	YEAR	ORDER CODE	MASTER TYPE	LINE LENGTH	PISTON-Ø	ASSEMBLY	SLAVE NO.	MASTER
BOMBARDIER DS 650 ATV	04 → 09	2100020	167 Black	1045 mm	9.5 mm	73	0120653	0723295
BMW F 800 Models	06 →	2100021	167 Black	1045 mm	12 mm	55 - 75	2100022	2700482
Suitable for application on F 800 R/F 800 S/F 800 ST/F 800 GT/F 800 GS (without handguards)/F 700 GS/F 650 GS (08 - 12)								
HARLEY DAVIDSON Big Twin* Big Twin* Sportster* Sportster* Sportster* Sportster* * for inch handlebars (ø 25.4 mm)	99 → 07 99 → 07 96 → 15 96 → 15 96 → 15 96 → 15	NA 0120614 B 0120601 0120602 0120611 0120612	80" Black 80" Chrome 80" Black 57" Black 80" Chrome 57" Chrome	2030 mm 2030 mm 2030 mm 1450 mm 2030 mm 1450 mm	10.5 mm 10.5 mm 10.5 mm 10.5 mm 10.5 mm 10.5 mm	NA NA 71 71 71 71	0722179 0722179 0722160 0722160 0722160 0722160	0722163 0722180 0722163 0722163 0722180 0722180
Big Twin-HYMEC only suitable for 5 speed gearbox models								
HONDA CBF 600 S / N (PC38) CBF 600 (PC43) NC 700 S NC 700 X NC 750 S NC 750 X	04 → 07 12 → 14 12 → 14 12 → 14 2015 2015	2100001 2100001 2100001 2100001 2100001 2100001	167 Black 167 Black 167 Black 167 Black 167 Black 167 Black	1045 mm 1045 mm 1045 mm 1045 mm 1045 mm 1045 mm	10.5 mm 10.5 mm 10.5 mm 10.5 mm 10.5 mm 10.5 mm	64 61 61 61 61 61	0120651 0120651 0120651 0120651 0120651 0120651	2700185 2700185 2700185 2700185 2700185 2700185
HUSQVARNA Nuda	12 → 14	2100021	167 Black	1045 mm	12 mm	55 - 75	2100022	2700482
KAWASAKI Z750 ER-6N Versys Z800 Z1000	09 → 12 06 → 09 07 → 10 13 → 15 10 → 15	0120689 0120689 0120689 2100309 2100309	167 Black 167 Black 167 Black 167 Black 167 Black	1045 mm 1045 mm 1045 mm 1045 mm 1045 mm	9.5 mm 9.5 mm 9.5 mm 10.5 mm 10.5 mm	65 65 65 55 55	0120651 0120651 0120651 0120655 0120655	0723295 0723295 0723295 2700185 2700185
SUZUKI SV 650	99 → 10	0120689	167 Black	1045 mm	9.5 mm	65	0120651	0723295
TRIUMPH Street Triple 675 Tiger 800 / 800 XC Tiger 800 XR	12 → 15 10 → 14 2015	2100303 2100303 2100303	167 Black 167 Black 167 Black	1120 mm 1120 mm 1120 mm	10.5 mm 10.5 mm 10.5 mm	H+32 H+32 H+32	2100308* 2100308* 2100308*	2700185 2700185 2700185
YAMAHA SR 400/500 FZ6	All 07 → 10	2100020 + Deco lever 0723189 0120689	167 Black 167 Black	1045 mm 1045 mm	9.5 mm 9.5 mm	73 65	0120653 0120651	0723295 0723295

B = Model still available while stocks last
NA = Not available

OE = Original Harley Clamp. Not included!
H + = Slave attached from rear cap with stud

Spare Parts on Pages 20/23

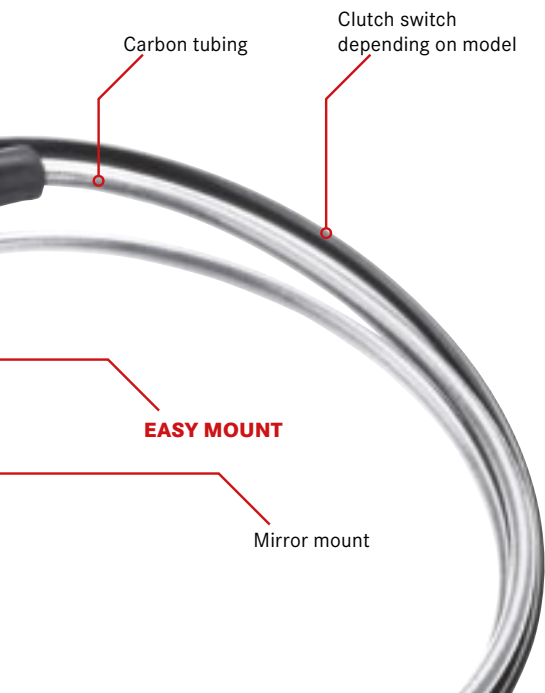

HYMEC for Harley



STREET-HYMEC

MAGURA HYMEC – An easy to install alternative to a mechanical clutch. This system replaces the clutch lever and cable – with a small lightweight hydraulic system for improved clutch control. The HYMEC ensures an easier operating pressure, a constant pressure point, no more cable adjustment and smooth clutch actuation to ensure the perfect take-off every time.

HYMEC significantly improves vehicle performance – it allows the user to feel the point where the clutch releases and actuates. This product has been developed over many years and been tested under the toughest conditions possible in the world of motorcycle Off-Road sport. It has been used by world champion riders who all agree as to the benefits but it is just as useful to the complete novice who stalls at the traffic lights. Due to demand MAGURA now offers the HYMEC system for various road going motorcycles.

MAKE / MODEL	ORDER CODE	PRESSURE LINE	LEVER	BRACKET	REAR CAP	PISTON KIT	CLAMP	NEW NOTE
BOMBARDIER DS 650 ATV	2100020	0722138	2700244	0430224	0430217	0723184	2700177	
BMW F 800 Models	2100021	0722138	0723296	NA	0430217	2700489	2700385	
Suitable for application on F 800 R/F 800 S/F 800 ST/F 800 GT/F 800 GS (without handguards)/F 700 GS/F 650 GS (08 - 12)								
HARLEY DAVIDSON Big Twin* Big Twin* Sportster* Sportster* Sportster* Sportster*	NA 0120614 B 0120601 0120602 0120611 0120612	0722178 0722178 0722162 0722161 0722162 0722161	0722182 0722182 0722167 0722167 0722182 0722182	NA NA NA NA NA NA	0430217 0430217 0430217 0430217 0430217 0430217	0722164 0722164 0722164 0722164 0722164 0722164	OE OE OE OE OE OE	Spares only Spares only
* for inch handlebars (ø 25.4mm) Big Twin-HYMEC only suitable for 5 speed gearbox models								
HONDA CBF 600 S / N (PC38) CBF 600 (PC43) NC 700 S NC 700 X NC 750 S NC 750 X	2100001 2100001 2100001 2100001 2100001 2100001	0722138 0722138 0722138 0722138 0722138 0722138	2700244 2700244 2700244 2700244 2700244 2700244	0430224 0430224 0430224 0430224 0430224 0430224	0430217 0430217 0430217 0430217 0430217 0430217	0723185 0723185 0723185 0723185 0723185 0723185	2700177 2700177 2700177 2700177 2700177 2700177	 NEW NEW
HUSQVARNA Nuda	2100021	0722138	0723296	NA	0430217	2700489	2700385	
KAWASAKI Z750 ER-6N Versys Z800 Z1000	0120689 0120689 0120689 2100309 2100309	0722138 0722138 0722138 0722138 0722138	2700244 2700244 2700244 0723296 0723296	0430224 0430224 0430224 0430224 0430224	0430217 0430217 0430217 0430217 0430217	0723184 0723184 0723184 0723185 0723185	2700177 2700177 2700177 2700177 2700177	 2014 2014
SUZUKI SV 650	0120689	0722138	2700244	0430224	0430217	0723184	2700177	
TRIUMPH Street Triple 675 Tiger 800 / 800 XC Tiger 800 XR	2100303 2100303 2100303	0722137 0722137 0722137	2700244 2700244 2700244	NA NA NA	2100018 2100018 2100018	0723185 0723185 0723185	2700177 2700177 2700177	 2014 2014 NEW
YAMAHA SR 400/500 FZ6	2100020 + Deco lever 0723189 0120689	0722138 0722138	2700244 2700244	0430224 0430224	0430217 0430217	0723184 0723184	2700177 2700177	

B = Model still available while stocks last
NA = Not available

OE = Original Harley Clamp. Not included!
H + = Slave attached from rear cap with stud

167 HYMEC | MASTER CYLINDER

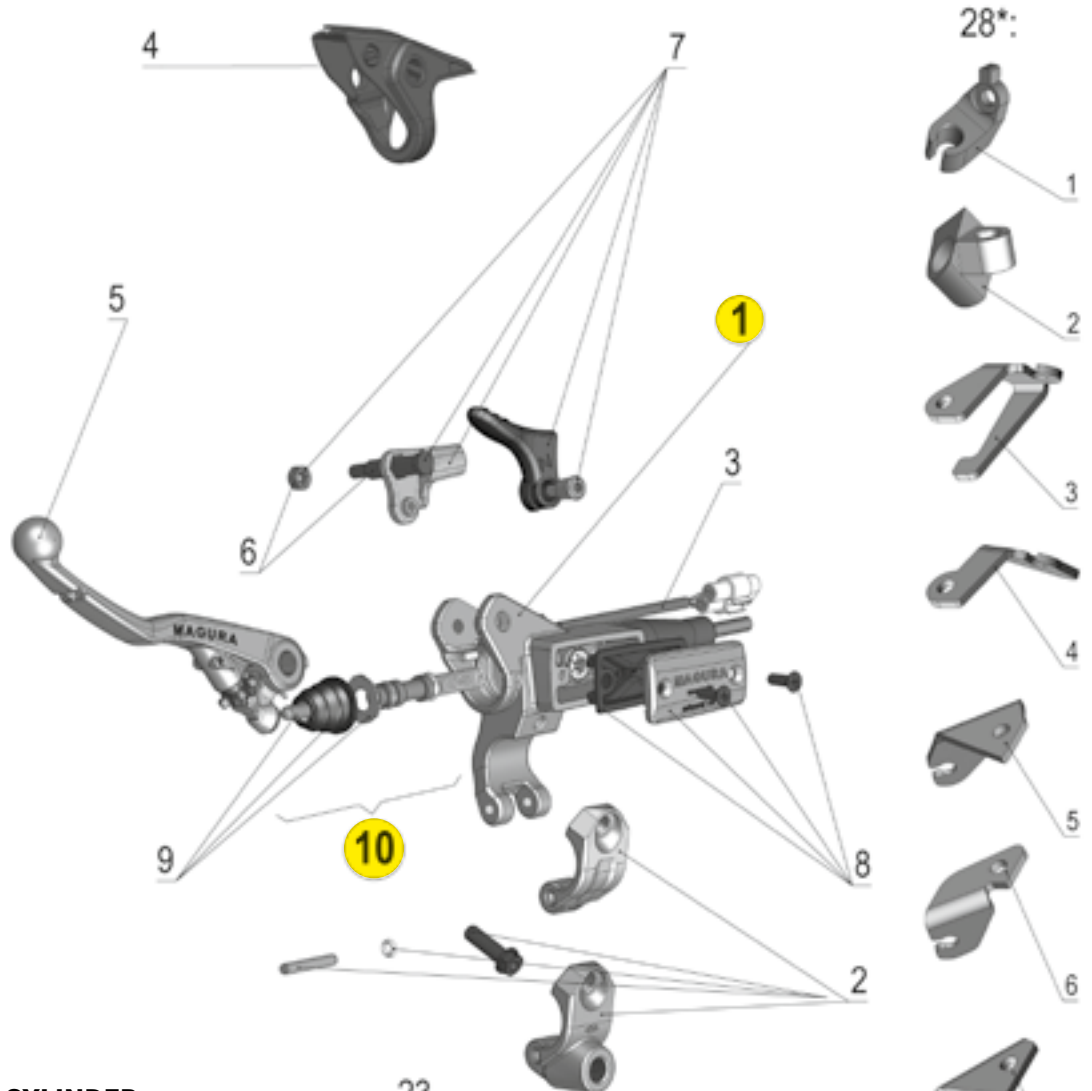

167 HYMEC | SLAVE CYLINDER

⚠ Slave cylinder seal-kits not available as spare parts!

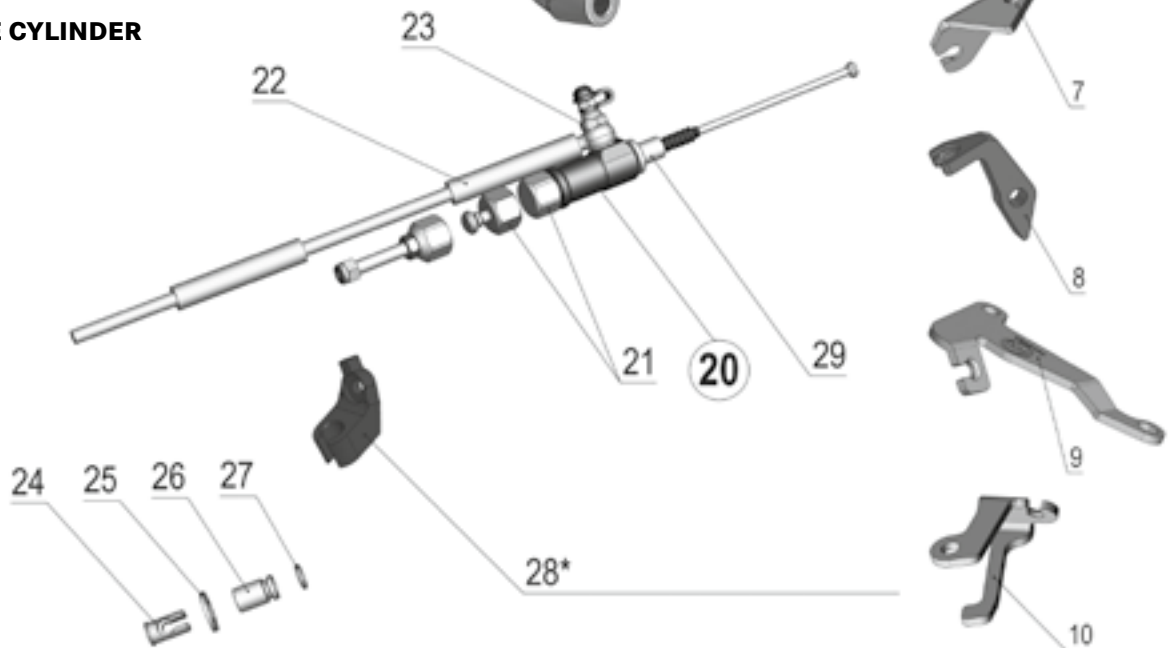

167 HYMEC | SPARE PARTS

POSITION	DESCRIPTION	ITEM CODE
1	Master cylinder*	Page36/37
2	Clamp with spiral spin Clamp for threaded mirror mounting M 10x1.25 mm Clamp for threaded mirror mount M 10x1.5mm (BMW)	2700176 2700177 2700385
3	Clutch switch Clutch switch BMW F 800 HYMEC	0723187 2700384
4	Protection cover for lever without choke lever Protection cover for lever with choke lever	0723163 0723202
5	Long lever blade with adjustment wheel l = 146 mm off-road Short lever blade with adjustment wheel l = 123 mm off-road Black lever blade with adjustment wheel l = 163 mm street Silver lever blade with adjustment wheel l = 163 mm street	0723290 0723121 0723296 2700244
6	Screw for lever without deco	0723115
7	Deco lever black Hot start lever red	0723189 0723188
8	Reservoir cover for mineral oil use with bellow and screws Reservoir cover for DOT use with bellow and screws	2700501 2700215
9	Bellows with push rod and washer	0723116
10	Master piston-Ø 9.5 mm mineral oil 10.5 mm mineral oil 12 mm mineral oil	0723184 0723185 2700489
20	Slave cylinder	Page 22/23
21	Cap bronze anodised Cap with stud bronze anodised Cap "universal"	0430217 0430998 2100018
22	TubeKIT CARBON with accessories l = 1,120 mm TubeKIT CARBON with accessories l = 1,045 mm TubeKIT PA with accessories (cut to size) l = 1,500 mm	0722137 0722138 0722679
23	Banjo bolt with bleeding valve for carbon tubings M 6x16.5 mm	0722136
24	Nipple	0412310
25	Spacer/Washer	0451530
26	Sleeve for 2-stroke 15 mm Sleeve for 2-stroke 12 mm	0430985 0430987
27	O-ring (needed for sleeve 0430985 and 0430987)	0488255
28	1. Mounting adapter Suzuki RM-Z 250, model year 2004-2008 1. Mounting adapter Kawasaki KXF 250, model year 2004-2008 2. Mounting adapter Honda CRF 450 R, model year 2004 3. Mounting adapter Kawasaki KX 450 F, model year 2006 4. Mounting adapter Honda CRF 450 R, model year 2004-2009 5. Mounting adapter Suzuki RM-Z 250, from model year 2009 6. Mounting adapter Suzuki RM-Z 450, from model year 2009 7. Mounting adapter Kawasaki KX 450 F, from model year 2009 8. Mounting adapter Honda CRF 250 R, from model year 2014 9. Mounting adapter Honda CRF 450 R, model year 2015 10. Mounting adapter Kawasaki KX 450 F, model year 2015	0430240 0430240 0430220 0430997 0431001 0430990 0430991 0431002 2401084 2401330 2401327
29	Support	0430224
30	MAGURA-Blood 100 ml MAGURA-Blood 1 liter Service-Kit HYMEC	0721820 0721821 0722152



OPTIONAL EXTRAS FOR YOUR SLAVE CYLINDER



Nipple: If your clutch cable has a large attachment nipple you will require a nipple for the end of your HYMEC slave cylinder activation rod.

Order code 0412310



Universal Attachment Kit: This kit facilitates the attachment of the HYMEC slave cylinder from the rear cap. It has an adjustable range and will add 55 to 70 mm to the activation length when used in conjunction with any of the slave cylinders listed on page 23.

Please note that the slave cylinder rear cap has a secondary breather function and should not be sealed when replaced.

Order code 2100018



Cap with Stud: If your HYMEC is attached from the rear you may require the cap with stud. This part is designed only for use with model specific adaptors.

Please note that the slave cylinder rear cap has a secondary breather function and should not be sealed when replaced.

Order code 0430998



Sleeve for 2 Stroke Models: If the HYMEC slave cylinder is located under the clutch cover it may be necessary to use one of the sleeves in conjunction with an o-ring.

Sleeve for 2-stroke models:

Order Code

0430985 15 mm long version

0430987 12 mm short version

0488255 O-ring fits both of the above versions

REPLACEMENT HYMEC CLUTCH SLAVE CYLINDERS

If you have an older HYMEC clutch activation system and require a replacement slave cylinder but are not aware of the correct part number we have devised a method to make it easier for you to establish the part number for the replacement.

Remove the slave cylinder from the motorcycle and activate the master cylinder until the slave cylinder activation rod is fully retracted and withdrawn. The piston in the slave cylinder is now contacting the bronze cap at the back of the slave cylinder and the rod length should be measured as shown in the table below. If the slave cylinder is no longer working it can be removed from the pressure line and forced slowly and carefully into the slave cylinder for the measurement.

Please note – the length you are measuring is not the activation length – the activation length is 16mm longer than the withdrawn length. Following the measurement please do not disregard your old slave cylinder you may require the cap or the support. All of our replacement HYMEC slave cylinders are delivered with the standard cap and standard support as shown in the pictures. If the slave cylinder you require lies between two different activation lengths – always order the longer version and use spacers between the support and the cable attachment to increase the activation length to suit your motorcycle.

SPECIAL REPLACEMENT HYMEC SLAVE CYLINDERS

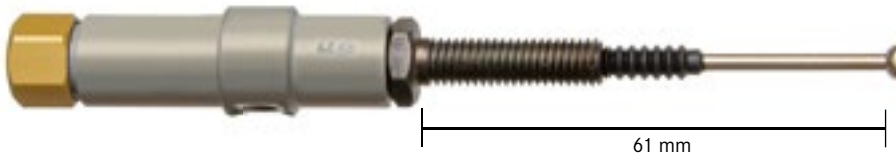

BMW F 800

- > F 700 GS
- > F 800 GS
- > F 800 R
- > F 800 S
- > F 800 ST
- > F 800 GT
- > F 650 GS (Twin)
- > HUSQVARNA NUDA

ACTIVATION LENGTH

57-78 mm

ITEM CODE

2100022



HARLEY SPORTSTER FROM 1996

Spacer block for assembly should be removed after installation.

ITEM CODE

0722160



BUELL XB-MODELLE 2002 – 2010

Spacer block for assembly should be removed after installation.

ITEM CODE

0120624

EXAMPLE



Replacement HYMEC Slave Cylinders – to measure your slave cylinder – activate the master cylinder until the pull rod is fully withdrawn.

	WITHDRAWN LENGTH	ACTIVATION LENGTH
A	16 mm	31–33 mm Order code 2100308
B	24 mm	39–41 mm Order code 0120649
C	31 mm	46–48 mm Order code 0120648
D	35 mm	51–53 mm Order code 0120655
E	41 mm	56–58 mm Order code 0120652
F	45 mm	60–62 mm Order code 0120651
G	50 mm	65–67 mm Order code 2100003
H	55 mm	70–72 mm Order code 0120653
I	67 mm	82–84 mm Order code 0120659
J	90 mm	105–107 mm Order code 0120657

BUILD YOUR OWN HYMEC HYDRAULIC CLUTCH!

The MAGURA Hymec system is world renowned as a hydraulic conversion for cable activated clutches. The system is compatible with most cable operated clutch systems and offers a direct constant pressure point. The advantages of the system are well documented in the press and riders forums. Any riders with small hands who have difficulty reaching the lever, and world

champion sports riders who require accuracy and single or 2-finger operation will immediately feel the benefits. Because we get constant requests for motorcycle models which we have never measured for the system we have put together this DIY information to assist customers to get the clutch they require.

WHAT DO I NEED TO BUILD A HYMEC FOR MY BIKE?

1. MASTER CYLINDER + 2. PRESSURE LINE, FITTINGS AND OIL + 3. SLAVE CYLINDER

1. MAGURA OFFER 3 MASTER CYLINDER OPTIONS:

Master Cylinder – as the system requires mineral oil and cannot be used with brake fluid the master cylinder should be mineral oil compatible.

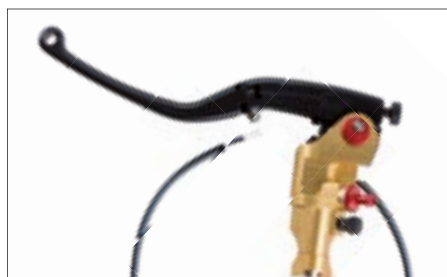

HC³ Fully Radial Master
Order Code 2100301
Max. slave stroke: 8-13 mm*
Full details on page 6



195 Slanted Radial Master
Order Code 0120691
Max. slave stroke: 10-13 mm*
Full details on page 12



167 Axial Master
Ø 9,5 Street (Light operation) Order Code 0723295
Max. slave stroke: 8-10 mm*
Ø 10,5 Street (Sports clutch) Order Code 2700185
Max. slave stroke: 10-12 mm*
Full details on page 37 and 20

HC³ - Reservoir, switch and banjo bolt included

195 - Reservoir, switch and banjo bolt NOT included

167 Street Master – switch, mirror clamp and black street lever included

Optional extras:
Mirror Clamp
Order Code 2700485

Optional extras:
Reservoir 195
Clutch Reservoir detached
Order Code 2700492
or Clutch Reservoir integrated
Order Code 2700787
Mirror Clamp Order Code 0722201

Optional extras:
Lever Silver
Order Code 2700244
Non mirror clamp
Order Code 2700176

2. PRESSURE LINE, FITTINGS AND SERVICE-KIT

PART DESCRIPTION	ORDER CODE	HC³	195	167
A Radial Pressure Line Adapter	2700497	x	x	-
B Banjo Bolt for master cylinder	0721786	-	x	-
C Clutch Switch	0722102	-	x	-
D Pressure Line L=1500 mm cut to size	0722679	- ¹⁾	- ¹⁾	x
D Pressure Line carbon L=1045 mm	0722138	x	x	x
D Pressure Line carbon L=1120 mm	0722137	x	x	x
E Banjo Bolt with Bleeder for slave	0722136	x	x	x
F Service-Kit HYMEC (Fill and Bleed Kit)	0722152	x	x	x

¹⁾ Pressure Line 0722679 is not suitable for use with radial pressure line adapter 2700497

Only one pressure line is required - there are 3 options available - please measure the cable before ordering

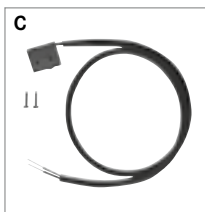

* Max. Slave stroke refers to possible max. stroke with lever adjusted to largest reach position.

3. SLAVE CYLINDER

In order to ascertain the correct slave cylinder for your motorcycle you will need to cut the template slave cylinder from this page, fit to the motorcycle and cut to size. If you do not feel qualified to remove the clutch cable please seek assistance from your local motorcycle technician.

There are 2 basic forms of slave cylinder attachment

1. Standard cable fitting: Slave template 1
2. Attached from rear: Slave template 2 (For longer assembly lengths the rear cap on the slave cylinder is replaced and attached between the cable attachment and clutch activation arm.)



Slave template 1



Slave template 2

SLAVE TEMPLATE 1

Carefully cut the template out and fit to your motorcycle. The clutch activation arm at the engine should be pushed with your finger as far forward towards the slave cylinder as possible and the template should then be cut at the next longest available point.

Then compare the number on the template to the list on page 23 to pick the correct slave cylinder. If the slave is too long it can be shortened by placing spacer washers between the slave and the mounting point - if it is too short it will not work correctly. If in doubt choose the longer version.

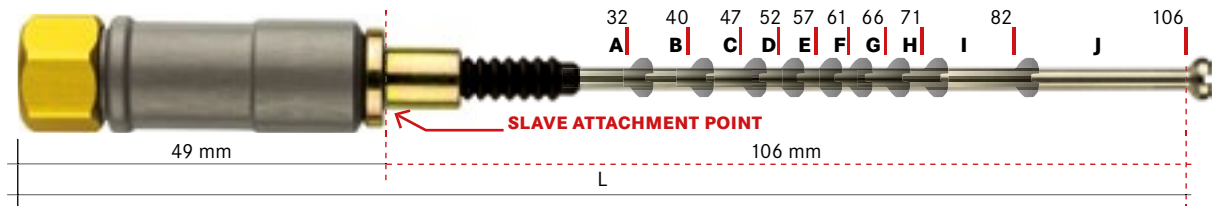

SLAVE TEMPLATE 2

Carefully cut the template out and fit to your motorcycle. The clutch activation arm at the engine should be pushed with your finger as far forward towards the slave cylinder as possible and the template should then be cut at the next longest available point. Then compare the number on the template to the list

on page 23 to pick the correct slave cylinder - you will also require **Order Code 2100018** Universal Attachment Kit to mount the slave from behind. The threaded attachment kit at the rear should allow for sufficient adjustability when installing the slave cylinder.

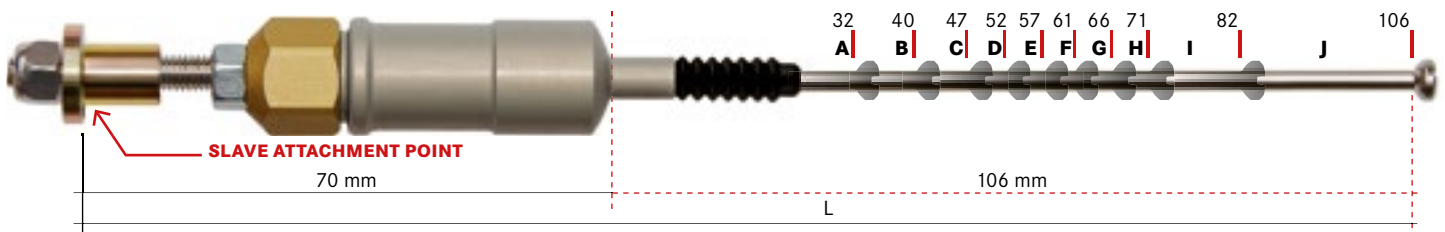

POSSIBLE SLAVE CYLINDER DEVIATIONS

Some motorcycle models require a large nipple to attach to the clutch activation arm

Some 2 stroke models have the cable fitted beneath an engine casing and require a special 2 stroke bracket.



Order Code 0430985 15 mm long version
Order Code 0430987 12 mm short version
Order Code 0488255 O-ring fits both of the above versions

CUSTOMER FEEDBACK:

Dear MAGURA Team, You have managed to amaze me. Just a few minutes ago I finished the installation work on my Kawasaki Versys 650 and have completed the initial test ride with the new HYMEC. What you have developed and built is simply sensational. I have a new motorcycle! That anything could have surprised me so much on my bike having already ridden over 40,000 km - I would never have imagined. Thank you - thank you for this great product. Heiko Bohn

BEFORE INSTALLING YOUR NEW HYMEC PLEASE DOWNLOAD THE CURRENT HYMEC-MANUAL FROM OUR WEBSITE! HYMEC DOES NOT AFFECT YOUR VEHICLE REGISTRATION.