

TECHNICAL & SERVICE MANUAL

OUTDOOR UNIT : AE2MI40AH
AE2MI56AHB
AE3MI68AH
AE4MI80AH



FILE NO.

Destination: Europe

DC INVERTER MULTI-SYSTEM AIR CONDITIONER

Capacity	Outdoor Model No.	Product Code No.
4.0kW	AE2MI40AH	3 870 310 85 (1 852 349 45)
5.6kW	AE2MI56AHB	3 870 310 86 (1 852 349 46)
6.8kW	AE3MI68AH	3 870 310 87 (1 852 349 47)
8.0kW	AE4MI80AH	3 870 310 88 (1 852 349 48)

AE2MI40AH

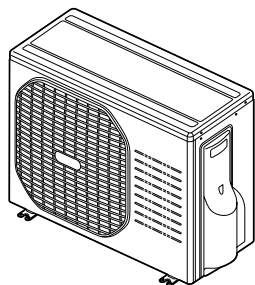

AE2MI56AHB
AE3MI68AH

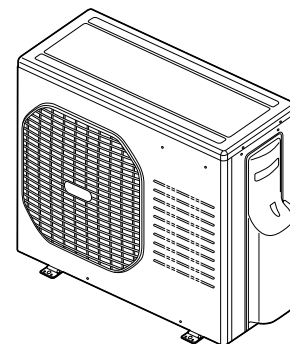

AE4MI80AH

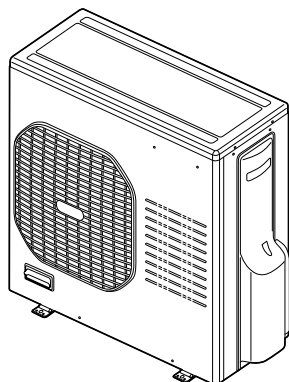

< Applicable Indoor Units >

- Wall mounted type
AWMI22AHL
AWMI27AHL
AWMI35AHL
AWI52AHL
AWI68AHL

NOTE

For details about the combination, refer to "Unit Combination Table" in the Appendix of this manual.

RoHS

- This product does not contain any hazardous substances prohibited by the **RoHS** Directive.

WARNING

- You are requested to use **RoHS** compliant parts for maintenance or repair.
- You are requested to use lead-free solder.

R410A

F-GAS REGULATION (EC) No 842 / 2006

Do not vent R410A into atmosphere : R410A is a fluorinated greenhouse gas, covered by Kyoto Protocol, with a Global Warming Potential (GWP) = 1975.

REFERENCE NO. SM700738

Important! Please Read Before Starting

This air conditioning system meets strict safety and operating standards. As the installer or service person, it is an important part of your job to install or service the system so it operates safely and efficiently.

For safe installation and trouble-free operation, you must:

- Carefully read this instruction booklet before beginning.
- Follow each installation or repair step exactly as shown.
- Observe all local, state, and national electrical codes.
- Pay close attention to all warning and caution notices given in this manual.



WARNING

This symbol refers to a hazard or unsafe practice which can result in severe personal injury or death.



CAUTION

This symbol refers to a hazard or unsafe practice which can result in personal injury or product or property damage.

If Necessary, Get Help

These instructions are all you need for most installation sites and maintenance conditions. If you require help for a special problem, contact our sales/service outlet or your certified dealer for additional instructions.

In Case of Improper Installation

The manufacturer shall in no way be responsible for improper installation or maintenance service, including failure to follow the instructions in this document.

SPECIAL PRECAUTIONS

WARNING When Wiring



ELECTRICAL SHOCK CAN CAUSE SEVERE PERSONAL INJURY OR DEATH. ONLY A QUALIFIED, EXPERIENCED ELECTRICIAN SHOULD ATTEMPT TO WIRE THIS SYSTEM.

- Do not supply power to the unit until all wiring and tubing are completed or reconnected and checked.
- Highly dangerous electrical voltages are used in this system. Carefully refer to the wiring diagram and these instructions when wiring. Improper connections and inadequate grounding can cause accidental injury or death.
- Ground the unit following local electrical codes.
- Connect all wiring tightly. Loose wiring may cause overheating at connection points and a possible fire hazard.
- Install a protective leakage breaker depending on the installation location (especially a damp or humid location). If a leakage breaker is not installed, electric shock can occur.

When Transporting

Be careful when picking up and moving the indoor and outdoor units. Get a partner to help, and bend your knees when lifting to reduce strain on your back. Sharp edges or thin aluminum fins on the air conditioner can cut your fingers.

When Installing

In a Ceiling or Wall

Make sure the ceiling/wall is strong enough to hold the unit's weight. It may be necessary to construct a strong wood or metal frame to provide added support.

In a Room

Properly insulate any tubing run inside a room to prevent "sweating" that can cause dripping and water damage to walls and floors.

In Moist or Uneven Locations

Use a raised concrete pad or concrete blocks to provide a solid, level foundation for the outdoor unit. This prevents water damage and abnormal vibration.

In an Area with High Winds

Securely anchor the outdoor unit down with bolts and a metal frame. Provide a suitable air baffle.

In a Snowy Area (for Heat Pump-type Systems)

Install the outdoor unit on a raised platform that is higher than drifting snow. Provide snow vents.

When Connecting Refrigerant Tubing

- Use the flare method for connecting tubing.
- Apply refrigerant lubricant to the matching surfaces of the flare and union tubes before connecting them, then tighten the nut with a torque wrench for a leak-free connection.
- Check carefully for leaks before starting the test run.

When Servicing

- Turn the power off at the main power box (mains) before opening the unit to check or repair electrical parts and wiring.
- Keep your fingers and clothing away from any moving parts.
- Clean up the site after you finish, remembering to check that no metal scraps or bits of wiring have been left inside the unit being serviced.

Others



CAUTION

- Ventilate any enclosed areas when installing or testing the refrigeration system. Escaped refrigerant gas, on contact with fire or heat, can produce dangerously toxic gas.
- Confirm upon completing installation that no refrigerant gas is leaking. If escaped gas comes in contact with a stove, gas water heater, electric room heater or other heat source, it can produce dangerously toxic gas.

Table of Contents

	Page
■ APPLICABLE INDOOR UNITS	5
1. OPERATING RANGE	6
2. SPECIFICATIONS	
2-1. Unit Specifications	7
2-2. Major Component Specifications	11
2-3. Other Component Specifications	15
3. DIMENSIONAL DATA	16
4. REFRIGERANT FLOW DIAGRAM	
4-1. Refrigerant Flow Diagram	20
5. PERFORMANCE DATA	
5-1. Temperature Charts	24
6. ELECTRICAL DATA	
6-1. Electric Wiring Diagrams	41
7. FUNCTIONS	
7-1. Explanation of Functions	45
7-2. Protective Functions	49
8. TROUBLESHOOTING	
8-1. Precautions before Performing Inspection or Repair	52
8-2. Trouble Diagnosis by Error Monitor Lamps	53
8-3. Checking the Outdoor System	54
8-4. Trouble Diagnosis of Each Part	55
8-5. Trouble Diagnosis of Fan Motor	58
9. REFRIGERANT R410A:	
SPECIAL PRECAUTIONS WHEN SERVICING UNIT	
9-1. Characteristics of New Refrigerant R410A	59
9-2. Checklist before Servicing	59
9-3. Tools Specifically for R410A	61
9-4. Tubing Installation Procedures	61
9-5. In Case of Compressor Malfunction	62
9-6. In Case Refrigerant is Leaking	64
9-7. Charging Additional Refrigerant	65
9-8. Retro-Fitting Existing Systems	65

APPENDIX A	INSTALLATION INSTRUCTIONS	A-1
APPENDIX B	UNIT COMBINATION TABLES	A-2

■ APPLICABLE INDOOR UNITS

Indoor Unit Multi-Outdoor Unit		AWMI22AHL	AWMI27AHL	AWMI35AHL	AWI52AHL	AWI68AHL
		2-Room	AE2MI40AH	YES	YES	YES
2-Room	AE2MI56AHB	YES	YES	YES	YES	NO
4-Room	AE3MI68AH	YES	YES	YES	YES	YES
4-Room	AE4MI80AH	YES	YES	YES	YES	YES

- NOTE**
1. The table lists the wall-mounted type of indoor units as representative models.
 2. For details on the applicable indoor units other than the wall-mounted type, refer to the catalog.

1. OPERATING RANGE

	Temperature	Indoor Air Intake Temp.	Outdoor Air Intake Temp.
Cooling	Maximum	32 °C D.B. / 23 °C W.B.	43 °C D.B.
	Minimum	19 °C D.B. / 14 °C W.B.	19 °C D.B.
Heating	Maximum	27 °C D.B.	24 °C D.B. / 18 °C W.B.
	Minimum	16 °C D.B.	— D.B. / -15 °C W.B.

2. SPECIFICATIONS

2-1. Unit Specifications

Outdoor Unit **AE2MI40AH**
 Indoor Unit **AWMI27AHL × 2**

Type	2-Room Multi Outdoor Unit	
Number of Connectable Indoor Units	2	
Number of Operatable Indoor Units	2	
Max. Capacity of Operating Indoor Units	kW	6.15

Power Source	220 to 240V Single-Phase 50Hz
---------------------	-------------------------------

Voltage Rating	230V
-----------------------	------

Performance		Cooling	Heating
Capacity	kW	4.0 (2.0 to 5.0)	4.5 (2.2 to 5.5)
	BTU/h	13,600 (6,800 to 17,100)	15,400 (7,500 to 18,800)
Air Circulation (High)	m³/h	1,900	1,900

Electrical Rating		Cooling	Heating
Available Voltage Range	V	198 to 264	
Running Amperes	A	4.1	4.1
Power Input	W	925	925
Power Factor	%	98	98
E.E.R.	W/W	4.32	-
C.O.P.	W/W	-	4.86
Compressor Locked Rotor Amperes	A	14.5	

Features (Outdoor Unit)			
Control	Microprocessor		
Fan Speeds	Auto (Hi, Me, Lo)		
Compressor	DC Twin Rotary (Inverter)		
Refrigerant / Amount charged at shipment	kg	R410A / 1.7	
Refrigerant Control	Electric Expansion Valve		
Operation Sound	Hi	dB-A	47
			48
Refrigerant Tubing Connections	Flare Type		
Max. allowable tubing length per unit	m	20	
Refrigerant	Narrow tube	mm (in.)	6.35 (1/4") × 2
Tube Diameter	Wide tube	mm (in.)	9.52 (3/8") × 2

Dimensions & Weight (Outdoor Unit)			
Unit Dimensions			
Height × Width × Depth	mm	569 × 790 × 285	
Package Dimensions			
Height × Width × Depth	mm	645 × 920 × 385	
Weight	Net	kg	42.0
	Shipping	kg	45.0
Shipping Volume	m³	0.22	

DATA SUBJECT TO CHANGE WITHOUT NOTICE.

Remarks:

- The Values shown in performance section and electrical rating section above are based on the following unit combination.
 For other combination unit, please refer to the "Unit Combination Tables" in this manual.
 Indoor Unit : AWMI27AHL 2units Outdoor Unit : AE2MI40AH 1unit
- Rating conditions are: Cooling : Indoor air temp. 27°C D.B. / 19°C W.B. Heating : Indoor air temp. 20°C D.B.
 Outdoor air temp. 35°C D.B. / 24°C W.B. Outdoor air temp. 7°C D.B. / 6°C W.B.

Outdoor Unit **AE2MI56AHB**

Indoor Unit **AWMI27AHL × 1 + AWI52AHL × 1**

Type	2-Room Multi Outdoor Unit	
Number of Connectable Indoor Units	2	
Number of Operatable Indoor Units	2	
Max. Capacity of Operating Indoor Units	kW	8.65

Power Source	220 to 240V Single-Phase 50Hz
---------------------	-------------------------------

Voltage Rating	230V
-----------------------	------

Performance		Cooling	Heating
Capacity	kW	5.6 (2.1 to 6.8)	7.3 (2.4 to 8.4)
	BTU/h	19,100 (7,200 to 23,200)	24,900 (8,200 to 28,700)
Air Circulation (High)	m³/h	2,900	2,900

Electrical Rating		Cooling	Heating
Available Voltage Range	V	198 to 264	
Running Amperes	A	7.52	7.70
Power Input	W	1,695	1,735
Power Factor	%	98	98
E.E.R.	W/W	3.30	-
C.O.P.	W/W	-	4.21
Compressor Locked Rotor Amperes	A	14.5	

Features (Outdoor Unit)			
Control	Microprocessor		
Fan Speeds	Auto (Hi, Me, Lo)		
Compressor	DC Twin Rotary (Inverter)		
Refrigerant / Amount charged at shipment	kg	R410A / 2.8	
Refrigerant Control	Electric Expansion Valve		
Operation Sound	Hi	dB-A	50 52
Refrigerant Tubing Connections	Flare Type		
Max. allowable tubing length per unit	m	25	
Refrigerant	Narrow tube	mm (in.)	6.35 (1/4") × 2
Tube Diameter	Wide tube	mm (in.)	9.52 (3/8") × 2

Dimensions & Weight (Outdoor Unit)			
Unit Dimensions	Height × Width × Depth		
	mm	740 × 900 × 320	
Package Dimensions	Height × Width × Depth		
	mm	868 × 1,050 × 423	
Weight	Net	kg	65.0
	Shipping	kg	69.0
Shipping Volume	m³	0.38	

DATA SUBJECT TO CHANGE WITHOUT NOTICE.

Remarks:

- The Values shown in performance section and electrical rating section above are based on the following unit combination.
For other combination unit, please refer to the "Unit Combination Tables" in this manual.
Indoor Unit : AWMI27AHL 1unit + AWI52AHL 1unit Outdoor Unit : AE2MI56AHB 1unit
- Rating conditions are: Cooling : Indoor air temp. 27°C D.B. / 19°C W.B. Heating : Indoor air temp. 20°C D.B.
Outdoor air temp. 35°C D.B. / 24°C W.B. Outdoor air temp. 7°C D.B. / 6°C W.B.

Outdoor Unit **AE3MI68AH**
 Indoor Unit **AWMI27AHL × 3**

Type	4-Room Multi Outdoor Unit	
Number of Connectable Indoor Units	4	
Number of Operatable Indoor Units	3	
Max. Capacity of Operating Indoor Units	kW	12.2

Power Source	220 to 240V Single-Phase 50Hz
---------------------	-------------------------------

Voltage Rating	230V
-----------------------	------

Performance		Cooling	Heating
Capacity	kW	6.8 (2.9 to 8.1)	8.6 (3.4 to 9.0)
	BTU/h	23,200 (9,900 to 27,600)	29,300 (11,600 to 30,700)
Air Circulation (High)		m ³ /h	2,900

Electrical Rating		Cooling	Heating
Available Voltage Range	V	198 to 264	
Running Amperes	A	8.87	8.87
Power Input	W	2,000	2,000
Power Factor	%	98	98
E.E.R.	W/W	3.40	-
C.O.P.	W/W	-	4.30
Compressor Locked Rotor Amperes	A	14.5	

Features (Outdoor Unit)			
Control	Microprocessor		
Fan Speeds	Auto (Hi, Me, Lo)		
Compressor	DC Twin Rotary (Inverter)		
Refrigerant / Amount charged at shipment	kg	R410A / 2.8	
Refrigerant Control	Electric Expansion Valve		
Operation Sound	Hi	dB-A	50 52
Refrigerant Tubing Connections	Flare Type		
Max. allowable tubing length per unit	m	25	
Refrigerant	Narrow tube	mm (in.)	6.35 (1/4") × 4
Tube Diameter	Wide tube	mm (in.)	9.52 (3/8") × 3 + 12.7 (1/2") × 1

Dimensions & Weight (Outdoor Unit)			
Unit Dimensions			
Height × Width × Depth	mm	740 × 900 × 320	
Package Dimensions			
Height × Width × Depth	mm	868 × 1,050 × 423	
Weight	Net	kg	65.0
	Shipping	kg	69.0
Shipping Volume	m ³	0.38	

DATA SUBJECT TO CHANGE WITHOUT NOTICE.

Remarks:

- The Values shown in performance section and electrical rating section above are based on the following unit combination.
 For other combination unit, please refer to the "Unit Combination Tables" in this manual.
 Indoor Unit : AWMI27AHL 3units Outdoor Unit : AE3MI68AH 1unit
- Rating conditions are: Cooling : Indoor air temp. 27°C D.B. / 19°C W.B. Heating : Indoor air temp. 20°C D.B.
 Outdoor air temp. 35°C D.B. / 24°C W.B. Outdoor air temp. 7°C D.B. / 6°C W.B.

Outdoor Unit **AE4MI80AH**
 Indoor Unit **AWMI27AHL × 4**

Type	4-Room Multi Outdoor Unit	
Number of Connectable Indoor Units	4	
Number of Operatable Indoor Units	4	
Max. Capacity of Operating Indoor Units	kW	14.7

Power Source	220 to 240V Single-Phase 50Hz
---------------------	-------------------------------

Voltage Rating	230V
-----------------------	------

Performance		Cooling	Heating
Capacity	kW	8.0 (2.9 to 9.2)	9.4 (3.4 to 9.8)
	BTU/h	27,300 (9,900 to 31,400)	32,100 (11,600 to 33,400)
Air Circulation (High)	m ³ /h	3,070	3,070

Electrical Rating		Cooling	Heating
Available Voltage Range	V	198 to 264	
Running Amperes	A	7.58	8.96
Power Input	W	1,725	2,040
Power Factor	%	99	99
E.E.R.	W/W	4.64	-
C.O.P.	W/W	-	4.61
Compressor Locked Rotor Amperes	A	17.0	

Features (Outdoor Unit)			
Control	Microprocessor		
Fan Speeds	Auto (Hi, Me, Lo)		
Compressor	DC Twin Rotary (Inverter)		
Refrigerant / Amount charged at shipment	kg	R410A / 3.8	
Refrigerant Control	Electric Expansion Valve		
Operation Sound	Hi	dB-A	50 52
Refrigerant Tubing Connections	Flare Type		
Max. allowable tubing length per unit	m	30	
Refrigerant	Narrow tube	mm (in.)	6.35 (1/4") × 4
Tube Diameter	Wide tube	mm (in.)	9.52 (3/8") × 2 + 12.7 (1/2") × 2

Dimensions & Weight (Outdoor Unit)			
Unit Dimensions			
Height × Width × Depth	mm	890 × 900 × 320	
Package Dimensions			
Height × Width × Depth	mm	1,019 × 1,050 × 423	
Weight	Net	kg	82.0
	Shipping	kg	86.0
Shipping Volume	m ³	0.45	

DATA SUBJECT TO CHANGE WITHOUT NOTICE.

Remarks:

- The Values shown in performance section and electrical rating section above are based on the following unit combination.
 For other combination unit, please refer to the "Unit Combination Tables" in this manual.
 Indoor Unit : AWMI27AHL 4units Outdoor Unit : AE4MI80AH 1unit
- Rating conditions are: Cooling : Indoor air temp. 27°C D.B. / 19°C W.B. Heating : Indoor air temp. 20°C D.B.
 Outdoor air temp. 35°C D.B. / 24°C W.B. Outdoor air temp. 7°C D.B. / 6°C W.B.

2-2. Major Component Specifications

2-2-1. Outdoor Unit

Outdoor Unit **AE2MI40AH**

Control PCB		
Part No.		CB-CMRV1424EH
Controls		Microprocessor
Control Circuit Fuse		250V 25A
Compressor		
Type		DC Twin Rotary (Hermetic)
Compressor Model / Nominal Output		C-6RVN93H0M / 1,000W
Compressor Oil ... Amount	cc	FV50S ... 350
Coil Resistance (Ambient Temp. 20 °C)	Ohm	R - S : 0.482 S - T : 0.482 T - R : 0.482
Safety Device		
CT (Peak current cut-off control)		Yes
Compressor Discharge Temp. Control		Yes
Operation cut-off control in abnormal ambient Temp.		Yes
Overload Relay	Model	CS-7L115
	Operation Temp.	Open : 115 °C, Close : 95 °C
Run Capacitor	Micro F	-
	VAC	-
Crankcase Heater		-
Fan		
Type		Propeller
Q'ty ... Dia.	mm	1 ... D420
Fan Motor		
Type		DC Motor
Model ... Q'ty		DAJ12-55J71-CR ... 1
No. of Poles		8
Rough Measure RPM (Cool:Hi / Heat:Hi)		750 / 750
Nominal Output	W	50
Coil Resistance (Ambient Temp. 20 °C)	Ohm	RED - WHT : 77.5 WHT - BLU : 77.5 BLU - RED : 77.5
Safety Device		
Type		Internal Controller
Over-Current Protection		Yes
Run Capacitor	Micro F	-
	VAC	-
Heat Exchanger Coil		
Coil		Aluminum Plate Fin / Copper Tube
Rows		2
Fin Pitch	mm	13
Face Area	m ²	0.452
External Finish		
		Acrylic baked-on enamel finish

DATA SUBJECT TO CHANGE WITHOUT NOTICE.

Outdoor Unit **AE2MI56AHB**

Control PCB	
Part No.	CB-CMRV1924EH
Controls	Microprocessor
Control Circuit Fuse	250V 25A
Compressor	
Type	DC Twin Rotary (Hermetic)
Compressor Model / Nominal Output	5KD240XAB21 / 1,700W
Compressor Oil ... Amount	cc FV50S ... 900
Coil Resistance (Ambient Temp. 20 °C)	Ohm U - V : 0.720 V - W : 0.708 W - U : 0.726
Safety Device	
CT (Peak current cut-off control)	Yes
Compressor Discharge Temp. Control	Yes
Operation cut-off control in abnormal ambient Temp.	Yes
Overload Relay	Model CS-7LN115
Operation Temp.	Open : 115 °C, Close : 100 °C
Run Capacitor	Micro F - VAC -
Crankcase Heater	230V 25W
Fan	
Type	Propeller
Q'ty ... Dia.	mm 1 ... D460
Fan Motor	
Type	DC Motor
Model ... Q'ty	SIC-71FW-D490-1 ... 1
No. of Poles	8
Rough Measure RPM (Cool:Hi / Heat:Hi)	750 / 750
Nominal Output	W 90
Coil Resistance (Ambient Temp. 20 °C)	Ohm -
Safety Device	
Type	Internal Controller
Over-Current Protection	Yes
Over-Heat Protection	Yes
Run Capacitor	Micro F - VAC -
Heat Exchanger Coil	
Coil	Aluminum Plate Fin / Copper Tube
Rows	2
Fin Pitch	mm 1.4
Face Area	m ² 0.595
External Finish	
	Acrylic baked-on enamel finish

DATA SUBJECT TO CHANGE WITHOUT NOTICE.

Outdoor Unit **AE3MI68AH**

Control PCB	
Part No.	CB-CMRV2444EH
Controls	Microprocessor
Control Circuit Fuse	250V 25A
Compressor	
Type	DC Twin Rotary (Hermetic)
Compressor Model / Nominal Output	5KD240XAB21 / 1,700W
Compressor Oil ... Amount	cc FV50S ... 900
Coil Resistance (Ambient Temp. 20 °C)	Ohm U - V : 0.720 V - W : 0.708 W - U : 0.726
Safety Device	
CT (Peak current cut-off control)	Yes
Compressor Discharge Temp. Control	Yes
Operation cut-off control in abnormal ambient Temp.	Yes
Overload Relay	Model CS-7LN115
Operation Temp.	Open : 115 °C, Close : 100 °C
Run Capacitor	Micro F - VAC -
Crankcase Heater	230V 25W
Fan	
Type	Propeller
Q'ty ... Dia.	mm 1 ... D460
Fan Motor	
Type	DC Motor
Model ... Q'ty	SIC-71FW-D490-1 ... 1
No. of Poles	8
Rough Measure RPM (Cool:Hi / Heat:Hi)	750 / 750
Nominal Output	W 90
Coil Resistance (Ambient Temp. 20 °C)	Ohm -
Safety Device	
Type	Internal Controller
Over-Current Protection	Yes
Over-Heat Protection	Yes
Run Capacitor	Micro F - VAC -
Heat Exchanger Coil	
Coil	Aluminum Plate Fin / Copper Tube
Rows	2
Fin Pitch	mm 1.4
Face Area	m ² 0.595
External Finish	
	Acrylic baked-on enamel finish

DATA SUBJECT TO CHANGE WITHOUT NOTICE.

Outdoor Unit **AE4MI80AH**

Control PCB	
Part No.	CB-CMRV3144EH
Controls	Microprocessor
Control Circuit Fuse	250V 25A
Compressor	
Type	DC Twin Rotary (Hermetic)
Compressor Model / Nominal Output	5JD420XAB22 / 3,000W
Compressor Oil ... Amount	cc FV50S ... 1,200
Coil Resistance (Ambient Temp. 20 °C)	Ohm U - V : 0.435 V - W : 0.441 W - U : 0.452
Safety Device	
CT (Peak current cut-off control)	Yes
Compressor Discharge Temp. Control	Yes
Operation cut-off control in abnormal ambient Temp.	Yes
Overload Relay	Model CS-7LN115
Operation Temp.	Open : 115 °C, Close : 100 °C
Run Capacitor	Micro F - VAC -
Crankcase Heater	230V 25W
Fan	
Type	Propeller
Q'ty ... Dia.	mm 1 ... D460
Fan Motor	
Type	DC Motor
Model ... Q'ty	SIC-71FW-D490-1 ... 1
No. of Poles	8
Rough Measure RPM (Cool:Hi / Heat:Hi)	750 / 750
Nominal Output	W 90
Coil Resistance (Ambient Temp. 20 °C)	Ohm -
Safety Device	
Type	Internal Controller
Over-Current Protection	Yes
Over-Heat Protection	Yes
Run Capacitor	Micro F - VAC -
Heat Exchanger Coil	
Coil	Aluminum Plate Fin / Copper Tube
Rows	2
Fin Pitch	mm 1.4
Face Area	m ² 0.723
External Finish	
	Acrylic baked-on enamel finish

DATA SUBJECT TO CHANGE WITHOUT NOTICE.

2-3. Other Component Specifications

Sensor Name	Model No. of sensor	Quantity of Sensor			
		AE2MI40AH	AE2MI56AHB	AE3MI68AH	AE4MI80AH
Outdoor air temp sensor	TKS295B	1	1	1	1
Outdoor heat exchanger sensor	TKS292B	1	1	1	1
AW / AN sensor	TKS292B	1/1	1/1	1/1	1/1
BW / BN sensor	TKS292B	1/1	1/1	1/1	1/1
CW / CN sensor	TKS292B	0	0	1/1	1/1
DW / DN sensor	TKS292B	0	0	1/1	1/1

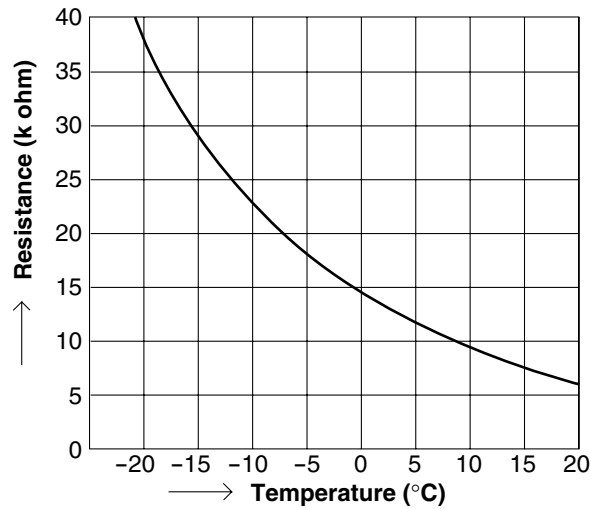

Sensor Name	Model No. of sensor	Quantity of Sensor			
		AE2MI40AH	AE2MI56AHB	AE3MI68AH	AE4MI80AH
Compressor temp sensor	TKS293B	1	1	1	1

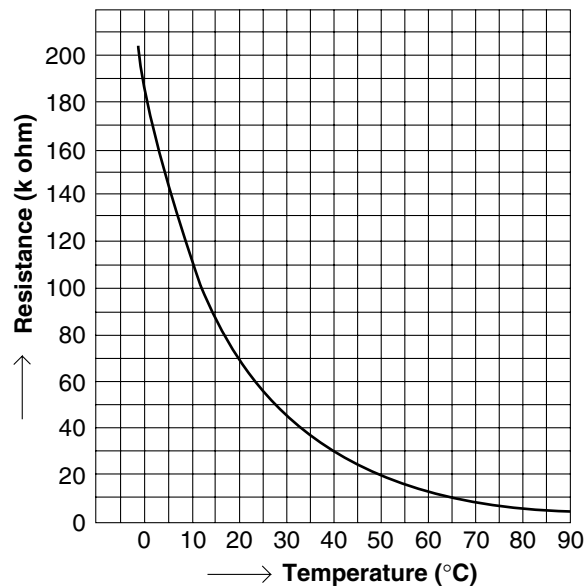

3. DIMENSIONAL DATA

Outdoor Unit AE2MI40AH

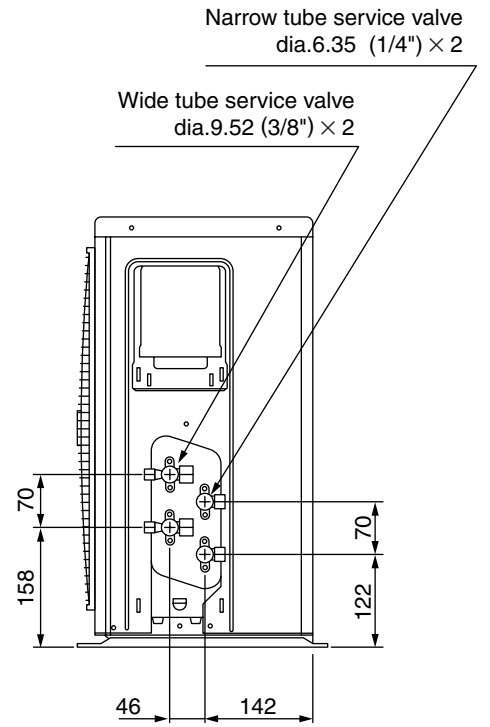
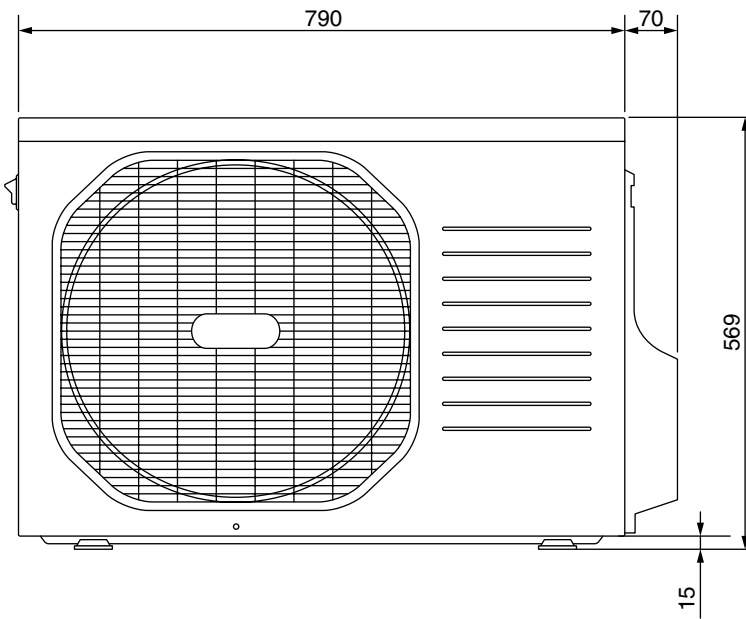
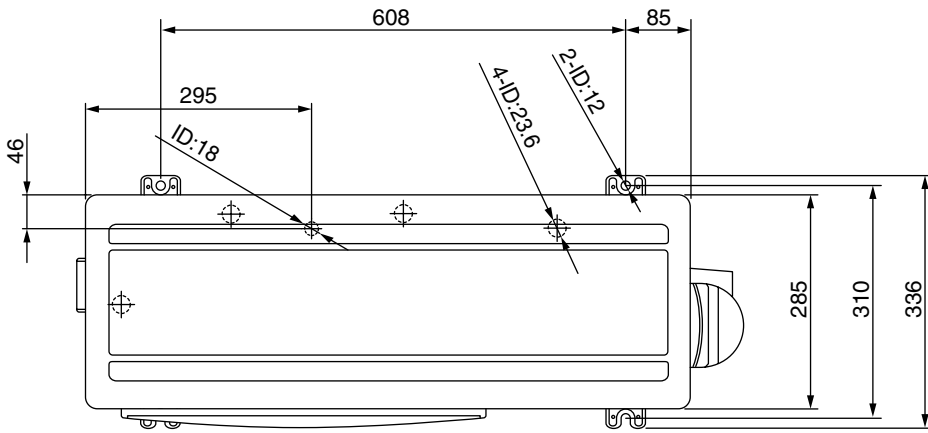

Unit: mm

Outdoor Unit **AE2MI56AHB**

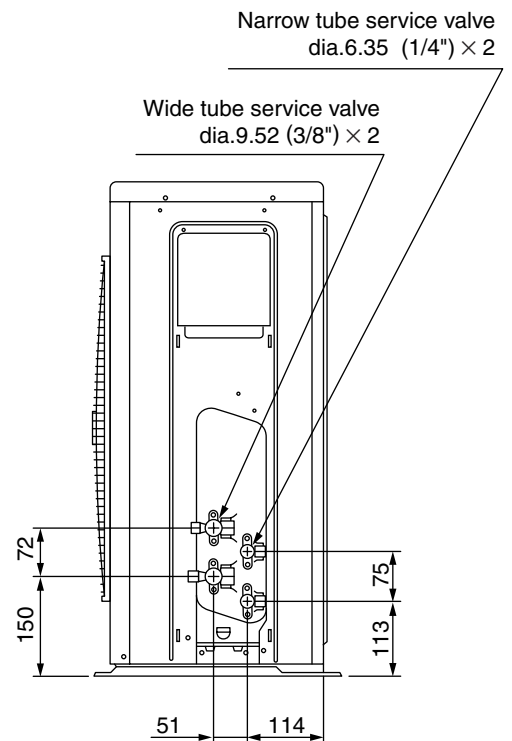
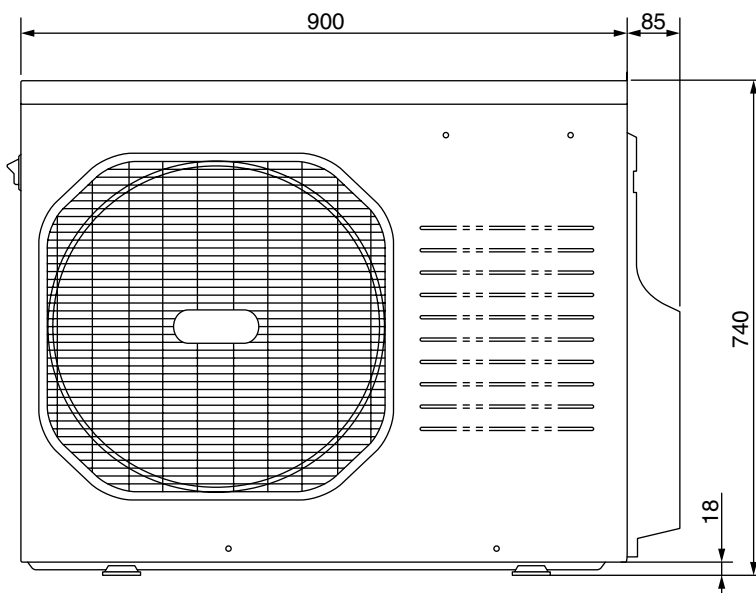
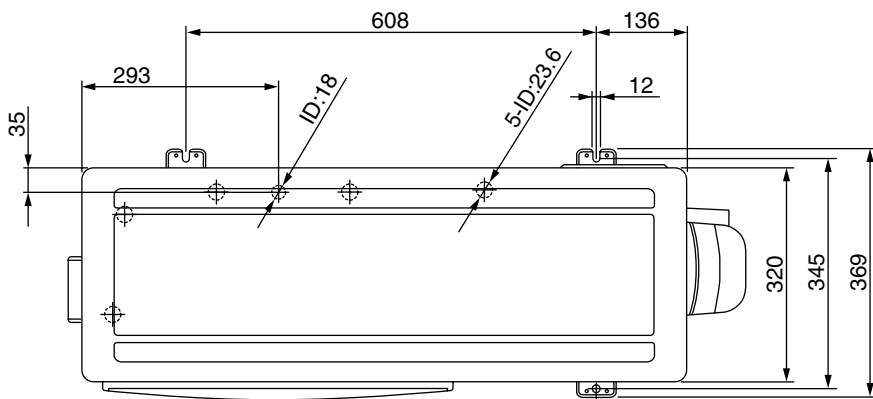

Unit: mm

Outdoor Unit **AE3MI68AH**

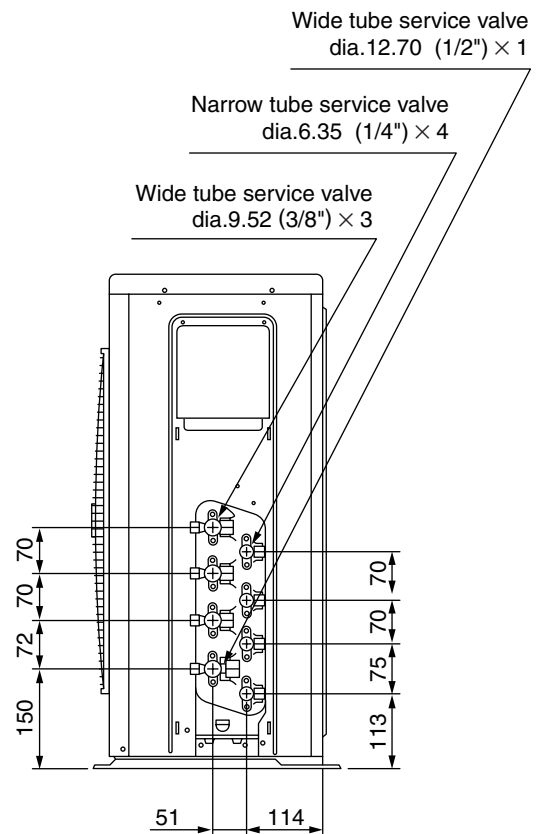
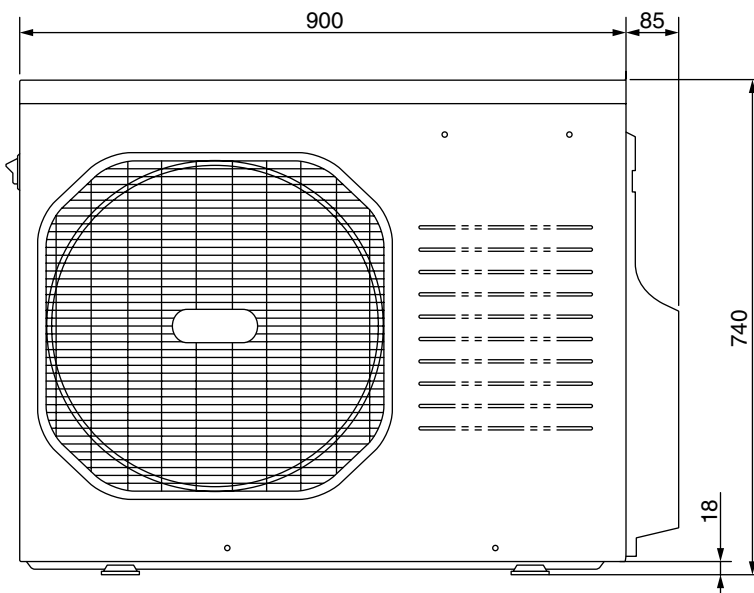
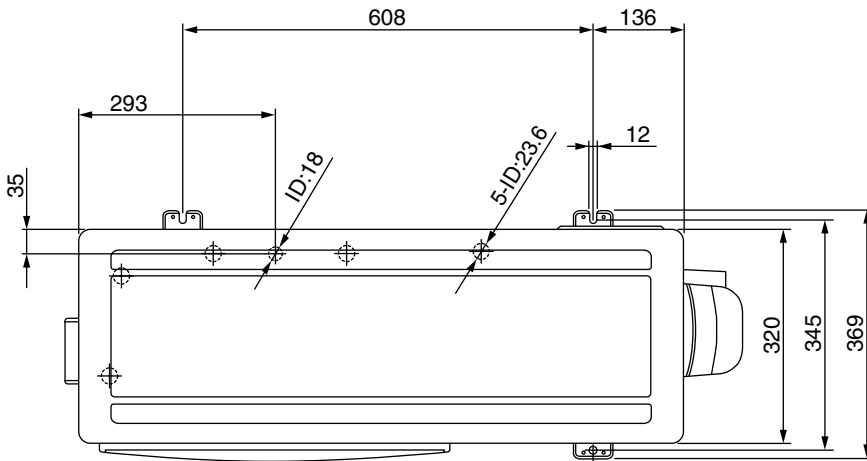

Unit: mm

Outdoor Unit **AE4MI80AH**

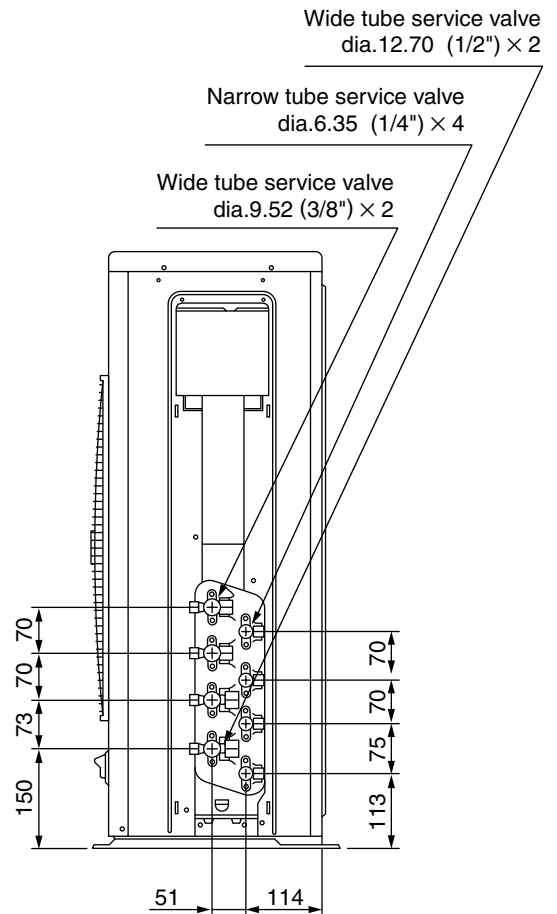
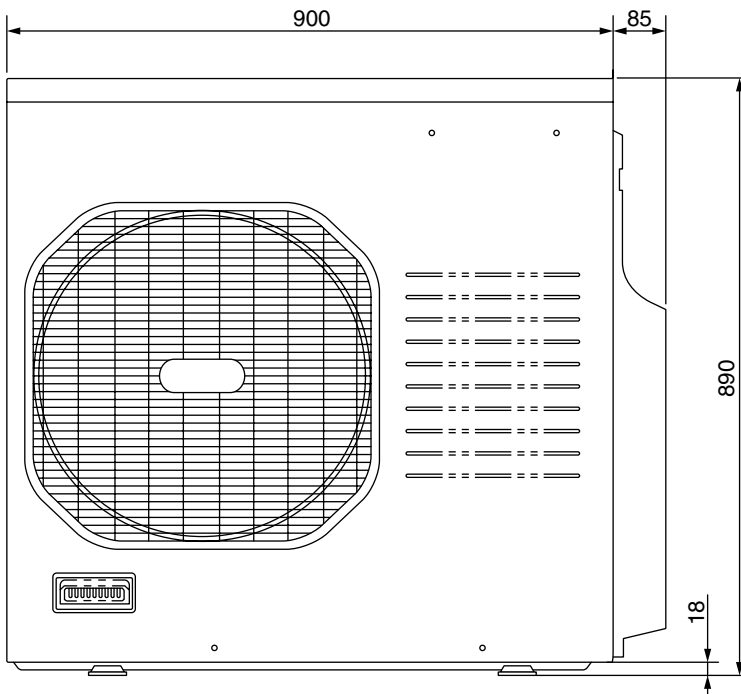
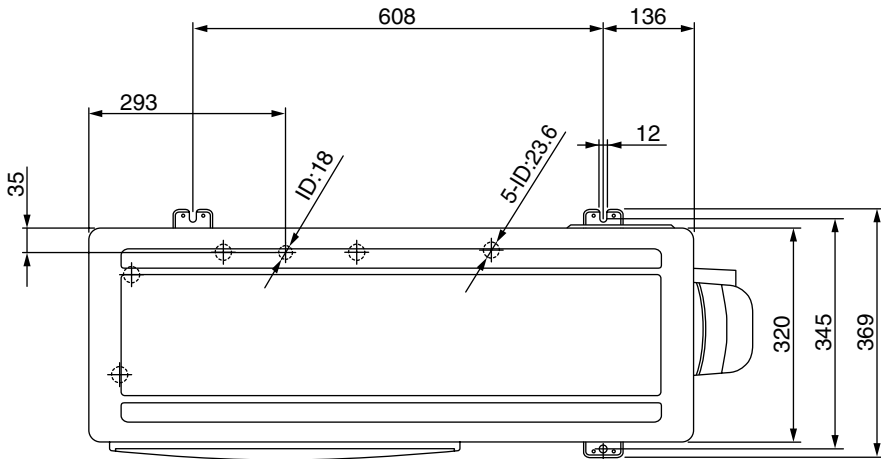

Unit: mm

4. REFRIGERANT FLOW DIAGRAM

4-1. Refrigerant Flow Diagram

Outdoor Unit AE2MI40AH

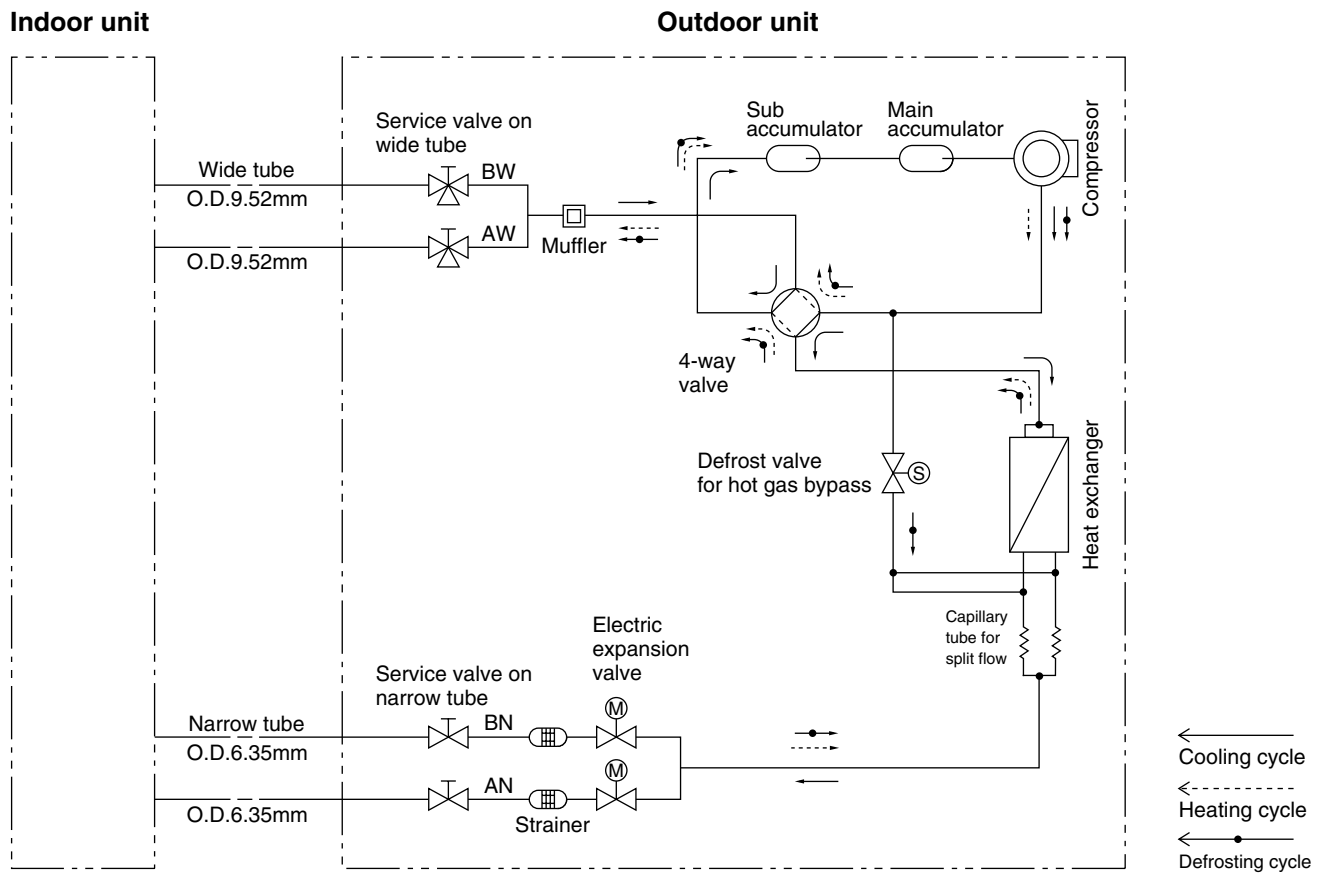

Insulation of Refrigerant Tubing

IMPORTANT

Because capillary tubing is used in the outdoor unit, both the wide and narrow tubes of this air conditioner become cold. To prevent heat loss and wet floors due to dripping of condensation, **both tubes must be well insulated** with a proper insulation material. The thickness of the insulation should be a min. 8 mm.



CAUTION

After a tube has been insulated, never try to bend it into a narrow curve because it can cause the tube to break or crack.

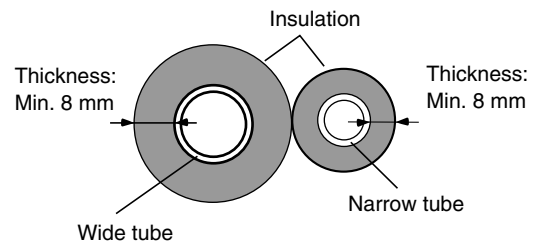

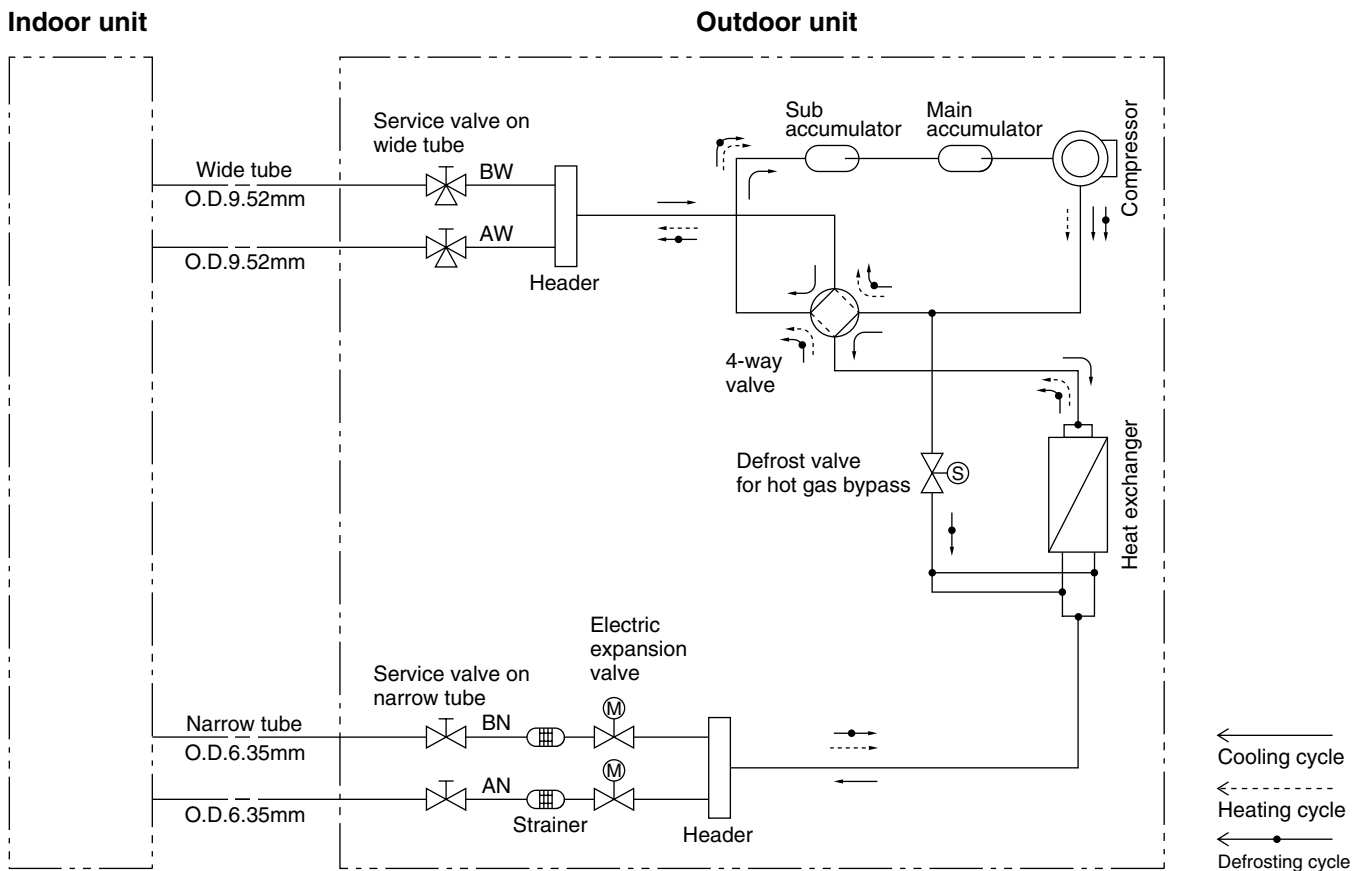

Insulation of Refrigerant Tubing

IMPORTANT

Because capillary tubing is used in the outdoor unit, both the wide and narrow tubes of this air conditioner become cold. To prevent heat loss and wet floors due to dripping of condensation, **both tubes must be well insulated** with a proper insulation material. The thickness of the insulation should be a min. 8 mm.



CAUTION

After a tube has been insulated, never try to bend it into a narrow curve because it can cause the tube to break or crack.

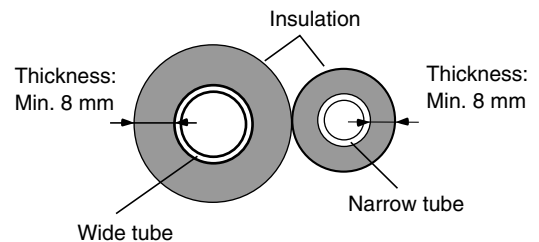

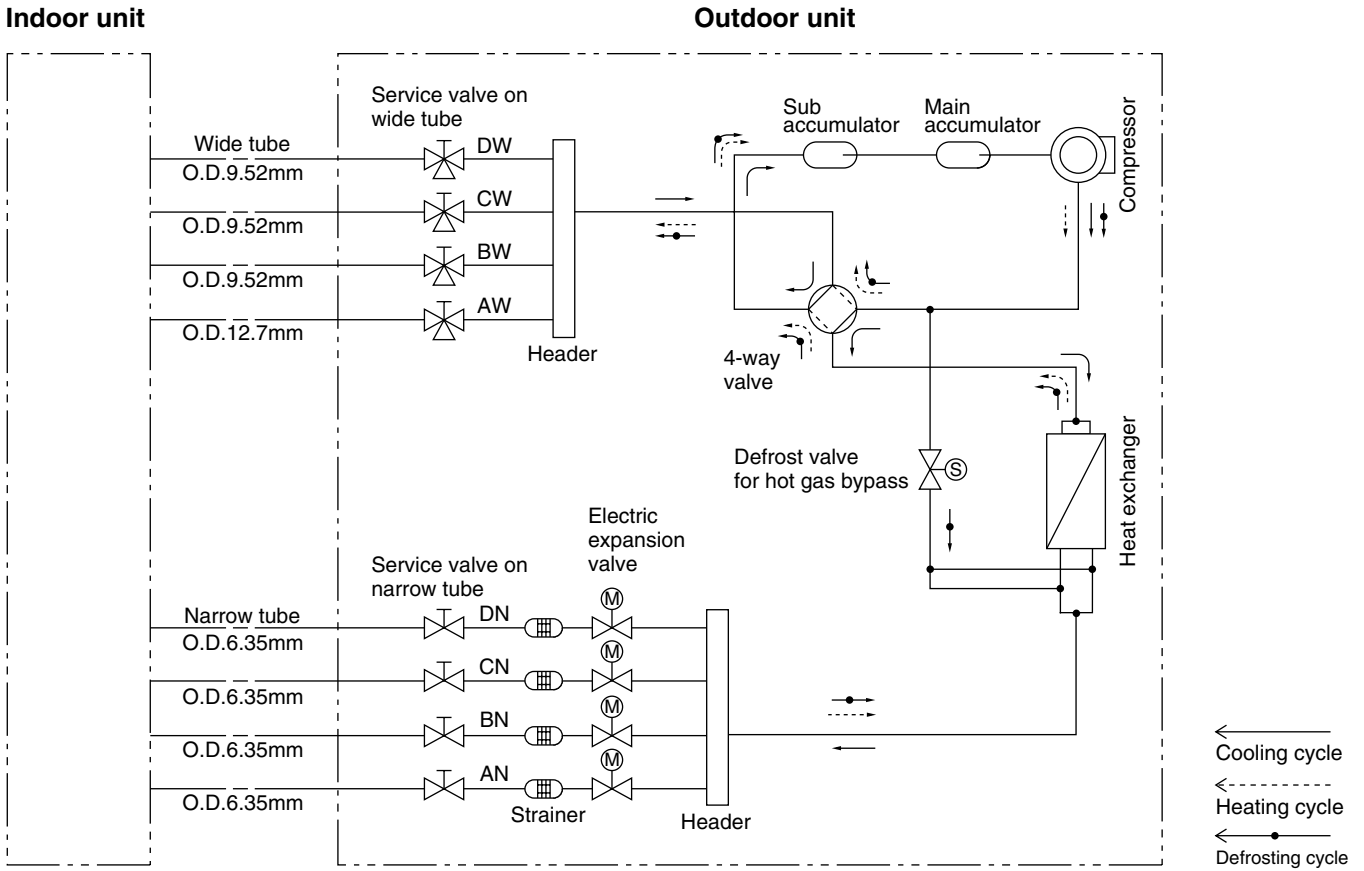

Insulation of Refrigerant Tubing

IMPORTANT

Because capillary tubing is used in the outdoor unit, both the wide and narrow tubes of this air conditioner become cold. To prevent heat loss and wet floors due to dripping of condensation, **both tubes must be well insulated** with a proper insulation material. The thickness of the insulation should be a min. 8 mm.



CAUTION

After a tube has been insulated, never try to bend it into a narrow curve because it can cause the tube to break or crack.

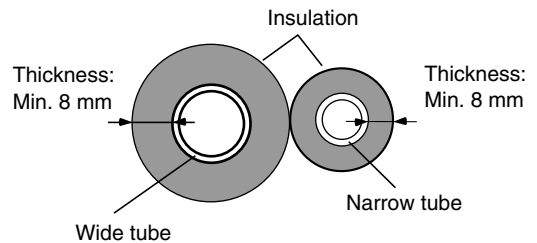

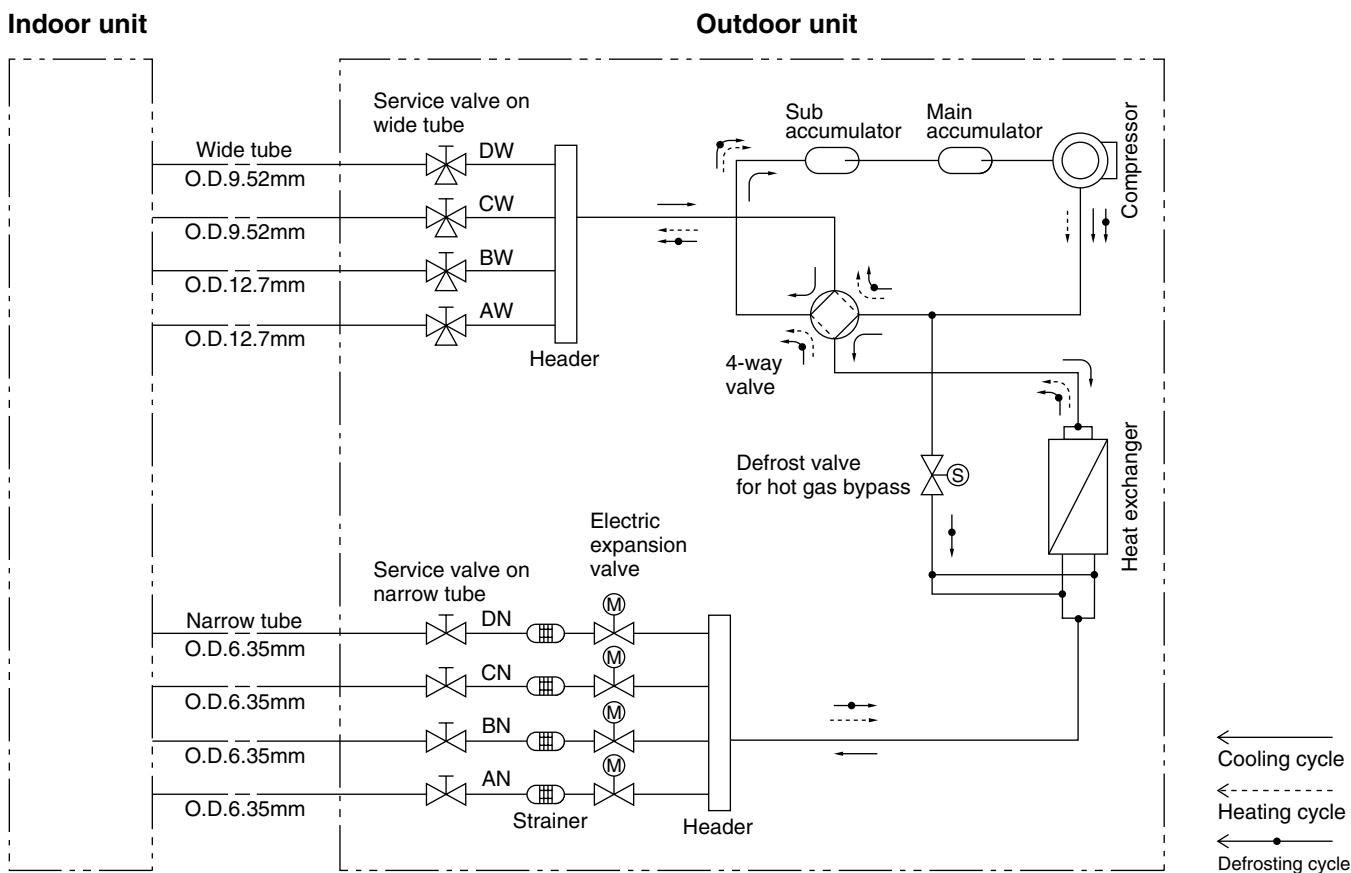

Insulation of Refrigerant Tubing

IMPORTANT

Because capillary tubing is used in the outdoor unit, both the wide and narrow tubes of this air conditioner become cold. To prevent heat loss and wet floors due to dripping of condensation, **both tubes must be well insulated** with a proper insulation material. The thickness of the insulation should be a min. 8 mm.



CAUTION

After a tube has been insulated, never try to bend it into a narrow curve because it can cause the tube to break or crack.

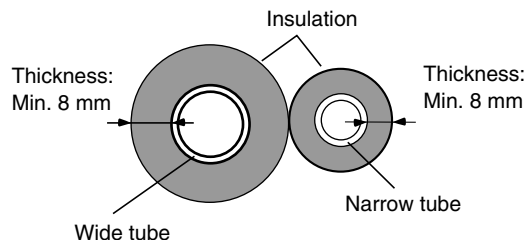

5. PERFORMANCE DATA

5-1. Temperature Charts

5-1-1. Temperature Charts (AE2MI40AH)

Outdoor Unit **AE2MI40AH** Indoor Unit **AWMI22AHL** × 1

■ **Cooling Characteristics**
 (RH : 46%, Indoor fan speed : High fan)
 (230V, 50Hz)

■ **Heating Characteristics**
 (RH : 85%, Indoor fan speed : High fan)
 (230V, 50Hz)

(1) Low pressure performance chart

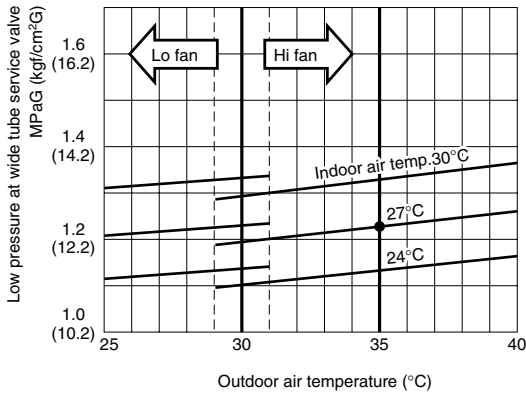

(1) High pressure performance chart

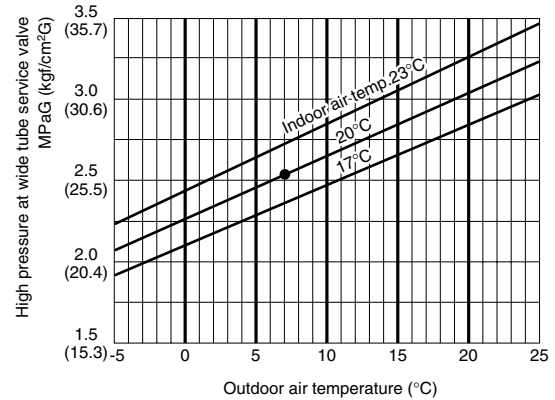

(2) Operating current performance chart

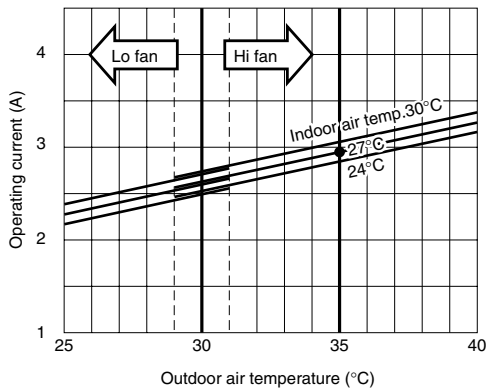

(2) Operating current performance chart

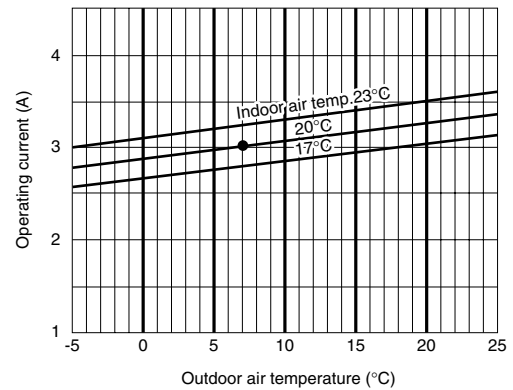

(3) Indoor discharge air performance chart

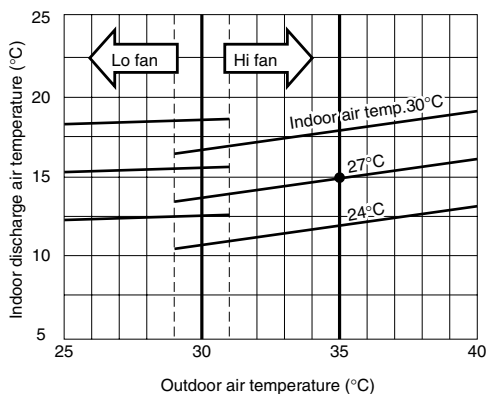

(3) Indoor discharge air performance chart

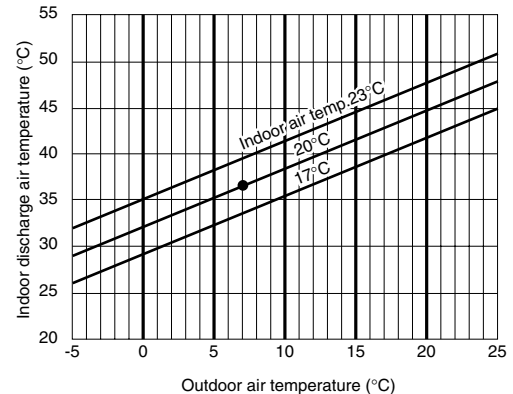

NOTE

- This performance chart shows operation of a single wall-mounted indoor unit. The performance chart will vary depending on the indoor unit type.
- Check each performance value in test-run mode. Electrical performance values represent a combined indoor/outdoor value. (In this case, be sure to stop all the indoor units where performance is not being checked.)
- The performance is for a tubing length of 7.5 m. If the tubing length is different, the performance chart will vary.

Outdoor Unit **AE2MI40AH** Indoor Unit **AWMI27AHL × 1**

■ **Cooling Characteristics**

(RH : 46%, Indoor fan speed : High fan)
(230V, 50Hz)

(1) Low pressure performance chart

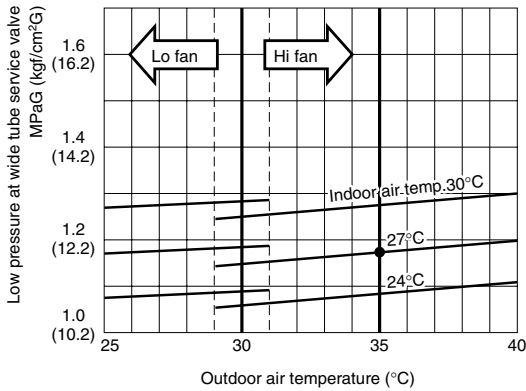

(2) Operating current performance chart

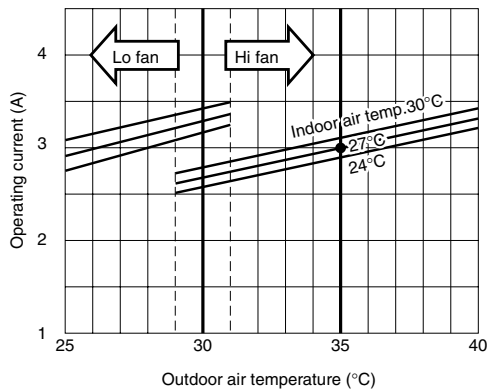

(3) Indoor discharge air performance chart

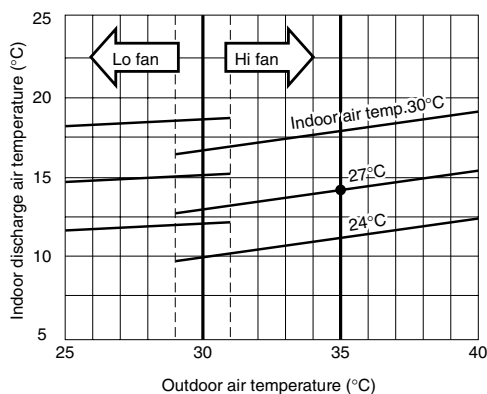

■ **Heating Characteristics**

(RH : 85%, Indoor fan speed : High fan)
(230V, 50Hz)

(1) High pressure performance chart

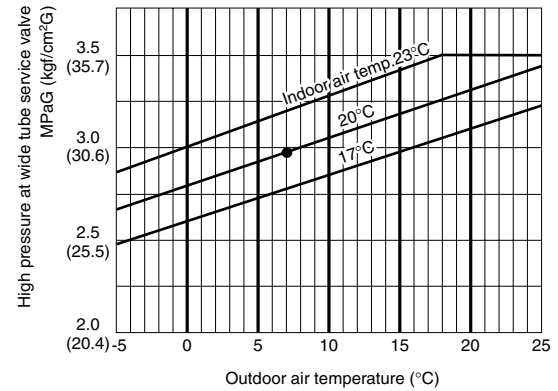

(2) Operating current performance chart

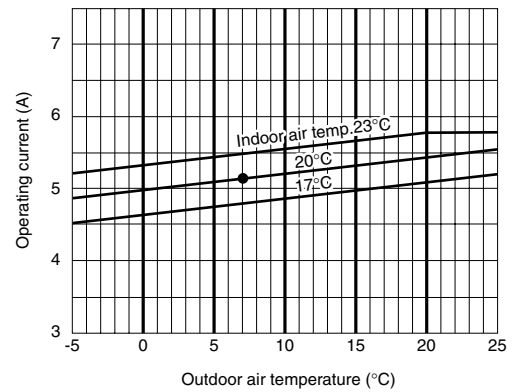

(3) Indoor discharge air performance chart

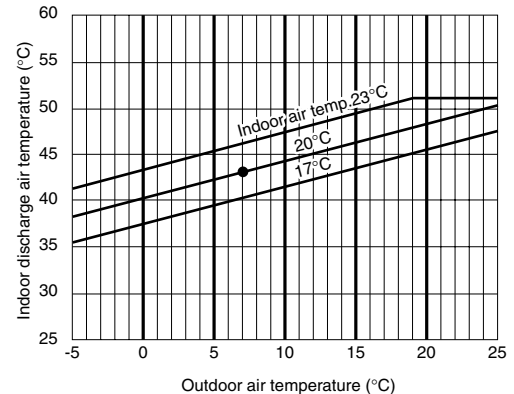

NOTE

- This performance chart shows operation of a single wall-mounted indoor unit. The performance chart will vary depending on the indoor unit type.
- Check each performance value in test-run mode. Electrical performance values represent a combined indoor/outdoor value. (In this case, be sure to stop all the indoor units where performance is not being checked.)
- The performance is for a tubing length of 7.5 m. If the tubing length is different, the performance chart will vary.

Outdoor Unit **AE2MI40AH** Indoor Unit **AWMI35AHL** × 1

■ **Cooling Characteristics**

(RH : 46%, Indoor fan speed : High fan)
(230V, 50Hz)

(1) Low pressure performance chart

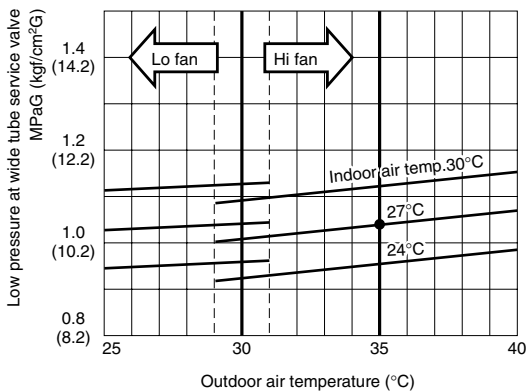

(2) Operating current performance chart

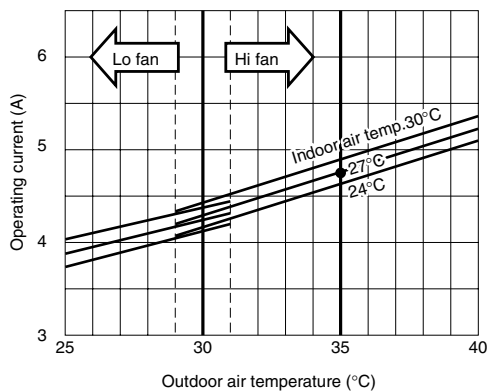

(3) Indoor discharge air performance chart

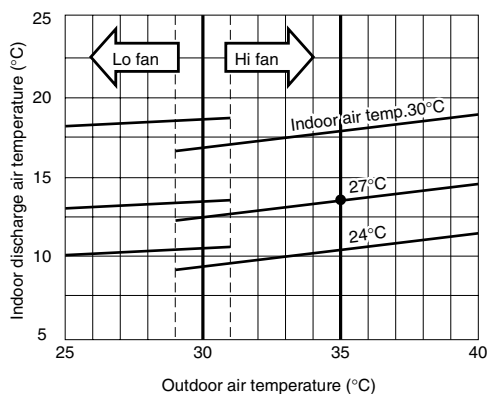

■ **Heating Characteristics**

(RH : 85%, Indoor fan speed : High fan)
(230V, 50Hz)

(1) High pressure performance chart

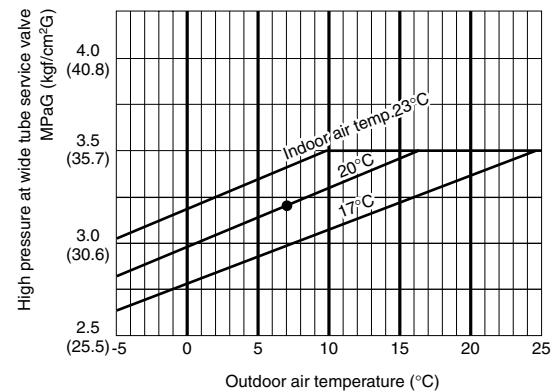

(2) Operating current performance chart

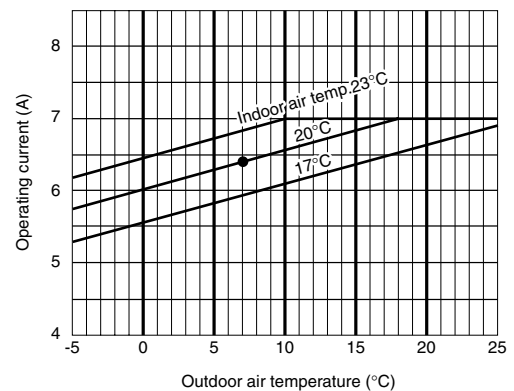

(3) Indoor discharge air performance chart

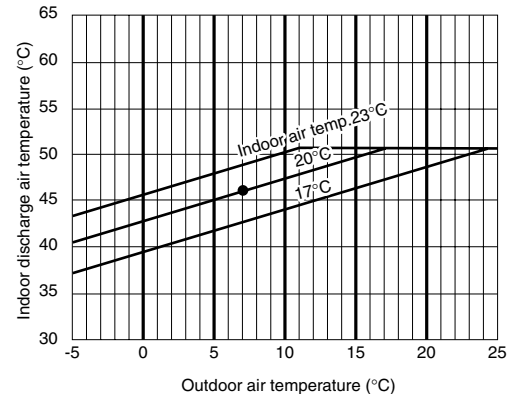

NOTE

- This performance chart shows operation of a single wall-mounted indoor unit. The performance chart will vary depending on the indoor unit type.
- Check each performance value in test-run mode. Electrical performance values represent a combined indoor/outdoor value. (In this case, be sure to stop all the indoor units where performance is not being checked.)
- The performance is for a tubing length of 7.5 m. If the tubing length is different, the performance chart will vary.

5-1-2. Temperature Charts (AE2MI56AHB)

Outdoor Unit **AE2MI56AHB** Indoor Unit **AWMI22AHL × 1**

■ Cooling Characteristics

(RH : 46%, Indoor fan speed : High fan)
(230V, 50Hz)

(1) Low pressure performance chart

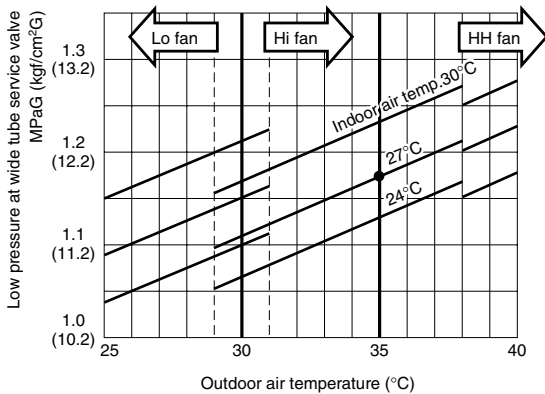

(2) Operating current performance chart

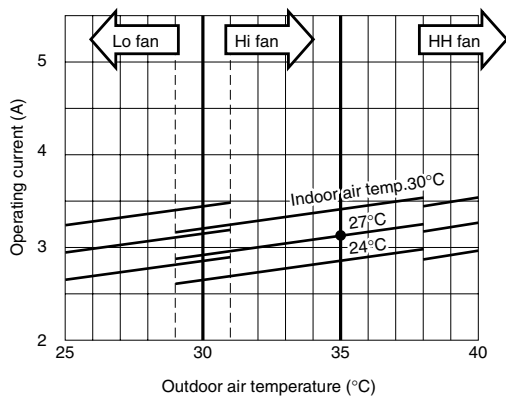

(3) Indoor discharge air performance chart

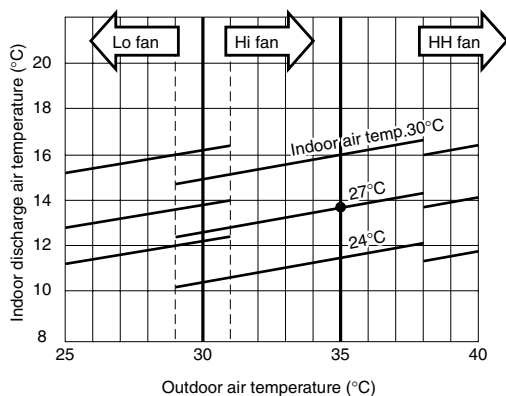

■ Heating Characteristics

(RH : 85%, Indoor fan speed : High fan)
(230V, 50Hz)

(1) High pressure performance chart

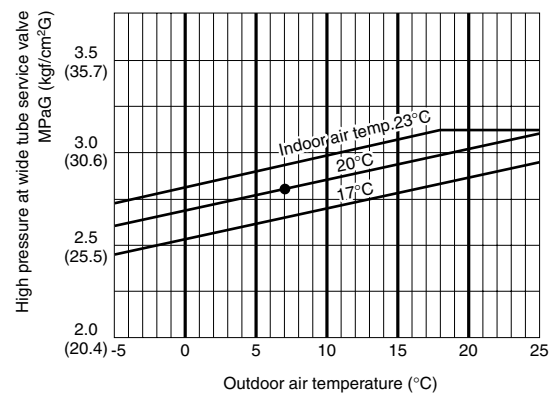

(2) Operating current performance chart

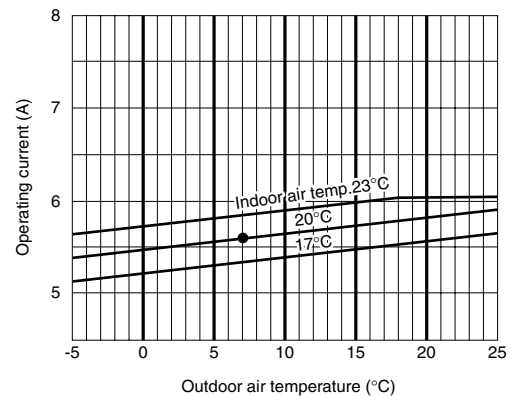

(3) Indoor discharge air performance chart

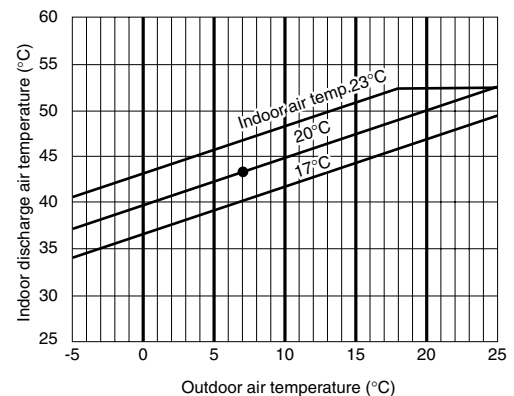

NOTE

- This performance chart shows operation of a single wall-mounted indoor unit. The performance chart will vary depending on the indoor unit type.
- Check each performance value in test-run mode. Electrical performance values represent a combined indoor/outdoor value. (In this case, be sure to stop all the indoor units where performance is not being checked.)
- The performance is for a tubing length of 7.5 m. If the tubing length is different, the performance chart will vary.

Outdoor Unit **AE2MI56AHB** Indoor Unit **AWMI27AHL** × 1

■ **Cooling Characteristics**

(RH : 46%, Indoor fan speed : High fan)
(230V, 50Hz)

(1) Low pressure performance chart

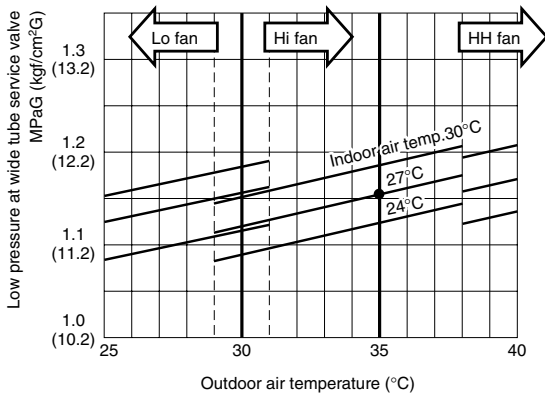

(2) Operating current performance chart

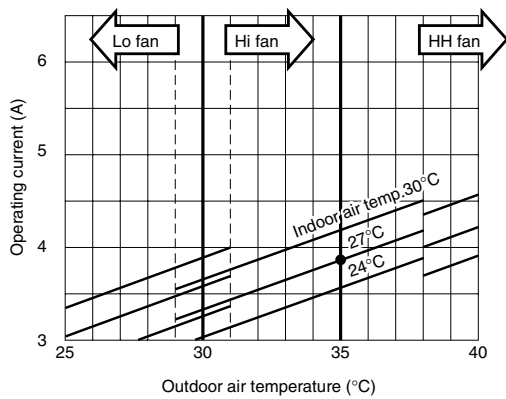

(3) Indoor discharge air performance chart

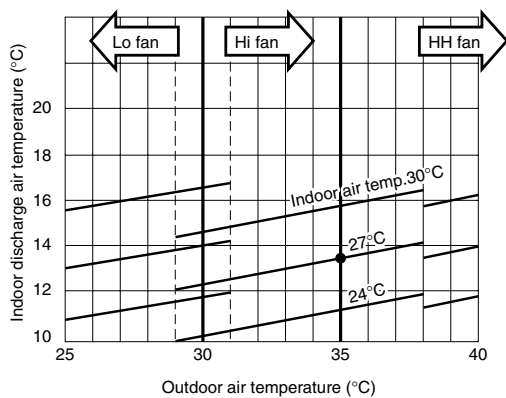

■ **Heating Characteristics**

(RH : 85%, Indoor fan speed : High fan)
(230V, 50Hz)

(1) High pressure performance chart

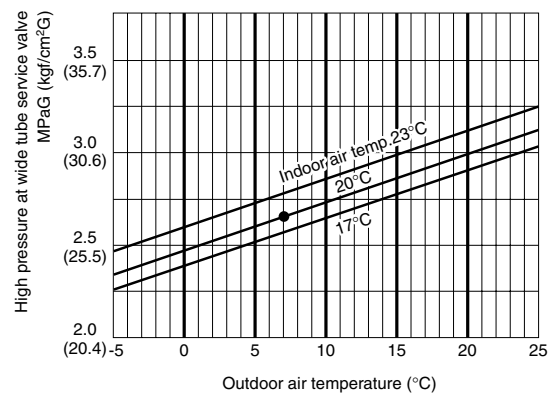

(2) Operating current performance chart

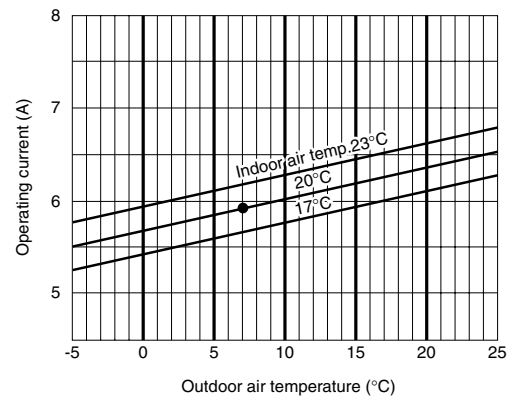

(3) Indoor discharge air performance chart

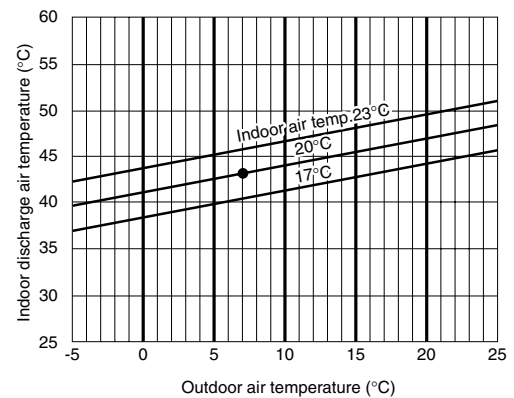

NOTE

- This performance chart shows operation of a single wall-mounted indoor unit. The performance chart will vary depending on the indoor unit type.
- Check each performance value in test-run mode. Electrical performance values represent a combined indoor/outdoor value. (In this case, be sure to stop all the indoor units where performance is not being checked.)
- The performance is for a tubing length of 7.5 m. If the tubing length is different, the performance chart will vary.

Outdoor Unit **AE2MI56AHB** Indoor Unit **AWMI35AHL × 1**

■ **Cooling Characteristics**

(RH : 46%, Indoor fan speed : High fan)
(230V, 50Hz)

(1) Low pressure performance chart

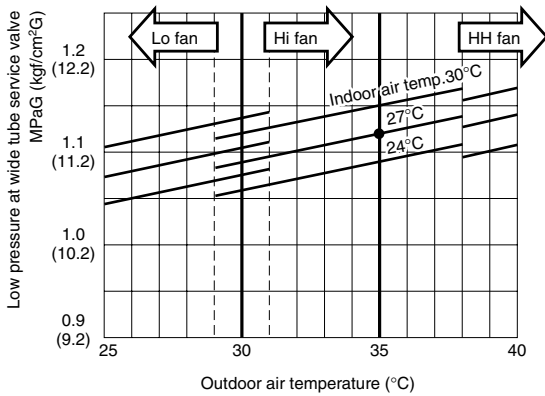

(2) Operating current performance chart

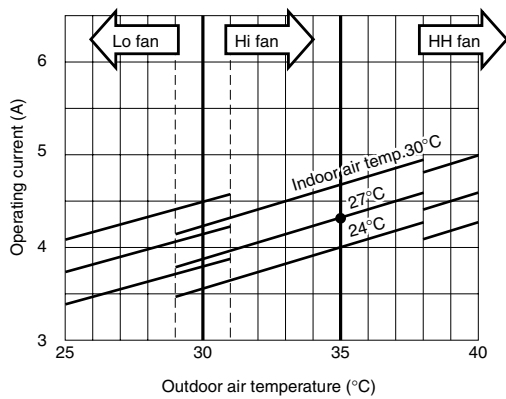

(3) Indoor discharge air performance chart

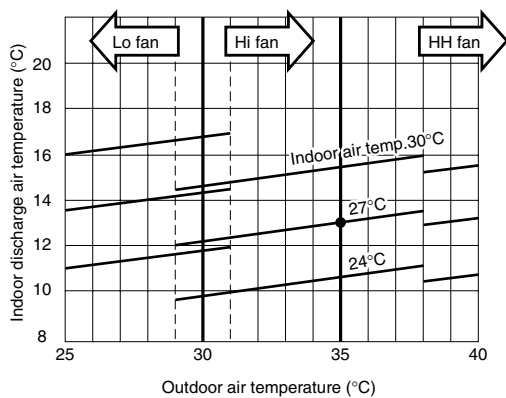

■ **Heating Characteristics**

(RH : 85%, Indoor fan speed : High fan)
(230V, 50Hz)

(1) High pressure performance chart

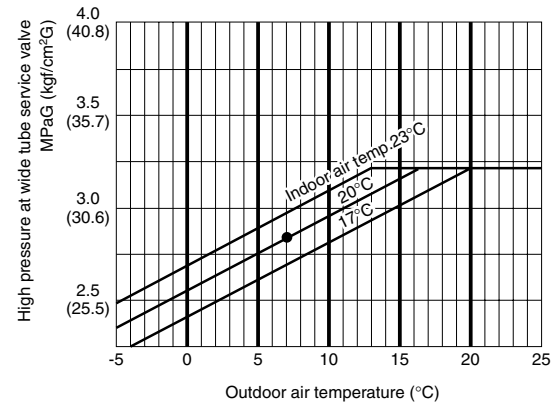

(2) Operating current performance chart

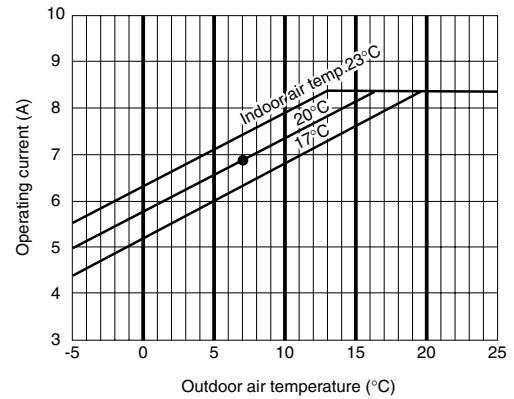

(3) Indoor discharge air performance chart

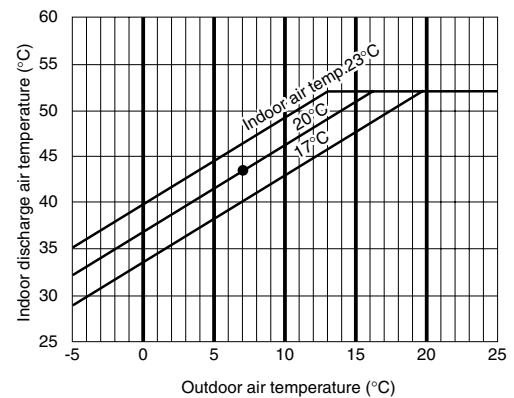

NOTE

- This performance chart shows operation of a single wall-mounted indoor unit. The performance chart will vary depending on the indoor unit type.
- Check each performance value in test-run mode. Electrical performance values represent a combined indoor/outdoor value. (In this case, be sure to stop all the indoor units where performance is not being checked.)
- The performance is for a tubing length of 7.5 m. If the tubing length is different, the performance chart will vary.

Outdoor Unit **AE2MI56AHB** Indoor Unit **AWI52AHL × 1**

■ **Cooling Characteristics**

(RH : 46%, Indoor fan speed : High fan)
(230V, 50Hz)

(1) Low pressure performance chart

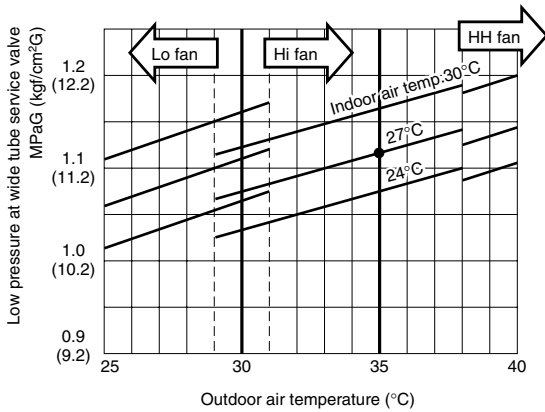

(2) Operating current performance chart

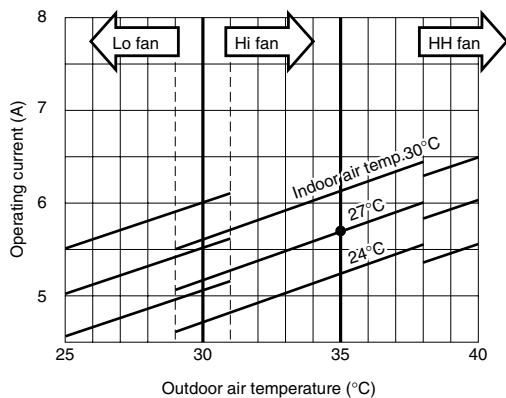

(3) Indoor discharge air performance chart

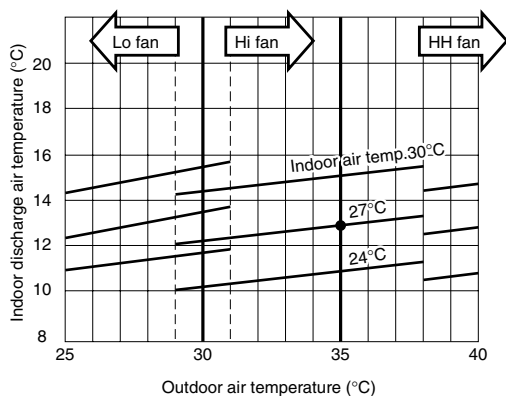

■ **Heating Characteristics**

(RH : 85%, Indoor fan speed : High fan)
(230V, 50Hz)

(1) High pressure performance chart

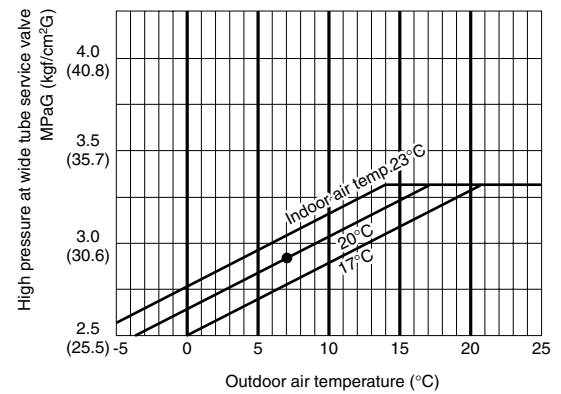

(2) Operating current performance chart

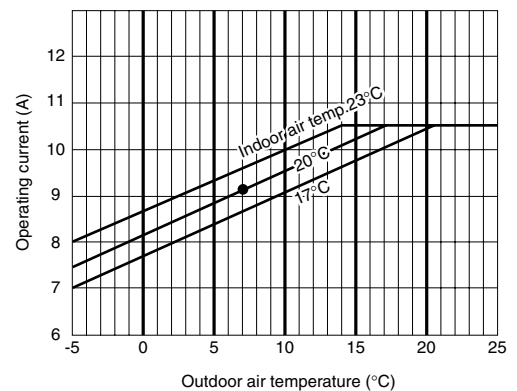

(3) Indoor discharge air performance chart

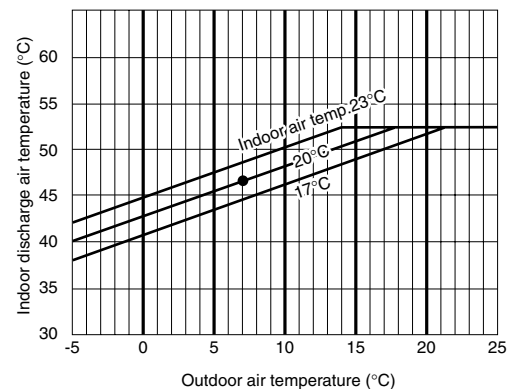

NOTE

- This performance chart shows operation of a single wall-mounted indoor unit. The performance chart will vary depending on the indoor unit type.
- Check each performance value in test-run mode. Electrical performance values represent a combined indoor/outdoor value. (In this case, be sure to stop all the indoor units where performance is not being checked.)
- The performance is for a tubing length of 7.5 m. If the tubing length is different, the performance chart will vary.

5-1-3. Temperature Charts (AE3MI68AH)

Outdoor Unit **AE3MI68AH** Indoor Unit **AWMI22AHL** × 1

■ Cooling Characteristics

(RH : 46%, Indoor fan speed : High fan)
(230V, 50Hz)

(1) Low pressure performance chart

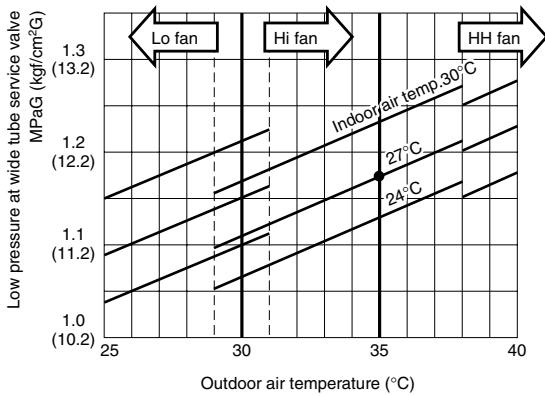

(2) Operating current performance chart

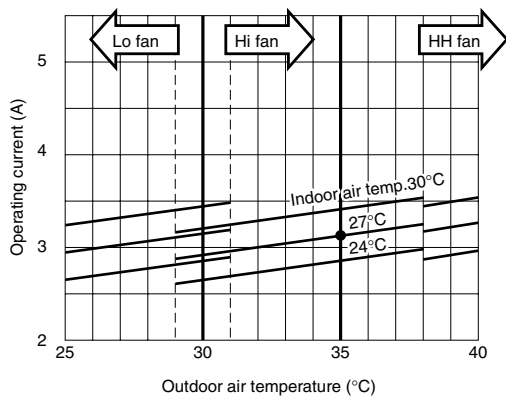

(3) Indoor discharge air performance chart

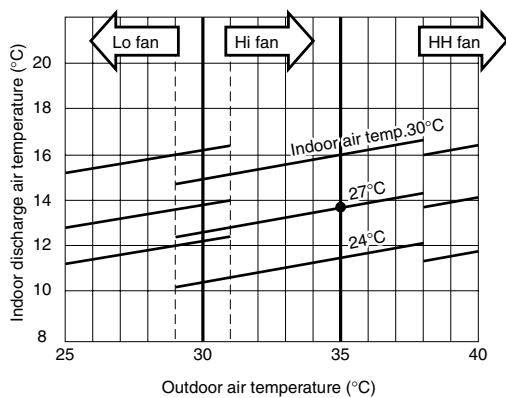

■ Heating Characteristics

(RH : 85%, Indoor fan speed : High fan)
(230V, 50Hz)

(1) High pressure performance chart

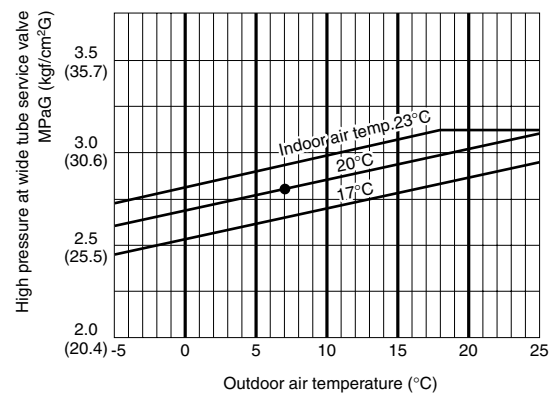

(2) Operating current performance chart

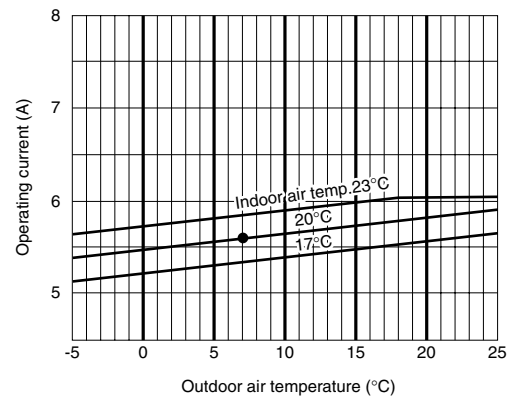

(3) Indoor discharge air performance chart

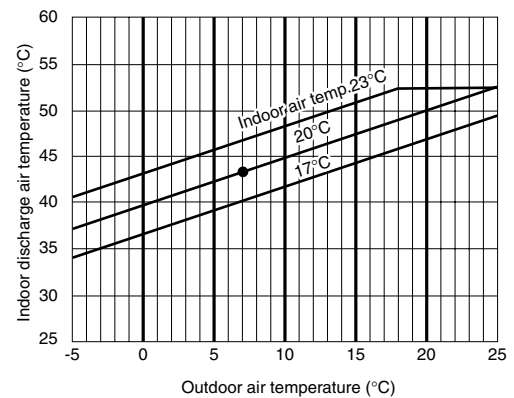

NOTE

- This performance chart shows operation of a single wall-mounted indoor unit. The performance chart will vary depending on the indoor unit type.
- Check each performance value in test-run mode. Electrical performance values represent a combined indoor/outdoor value. (In this case, be sure to stop all the indoor units where performance is not being checked.)
- The performance is for a tubing length of 7.5 m. If the tubing length is different, the performance chart will vary.

Outdoor Unit **AE3MI68AH** Indoor Unit **AWMI27AHL** × 1

■ **Cooling Characteristics**

(RH : 46%, Indoor fan speed : High fan)
(230V, 50Hz)

(1) Low pressure performance chart

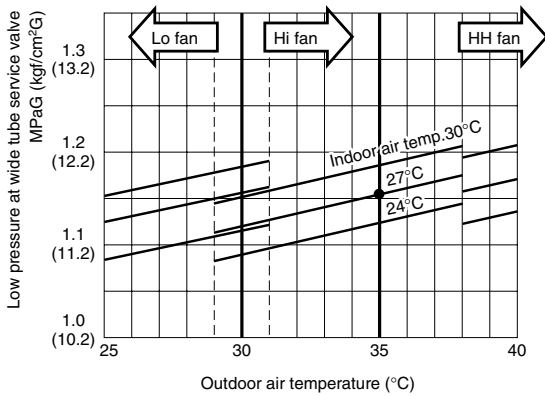

(2) Operating current performance chart

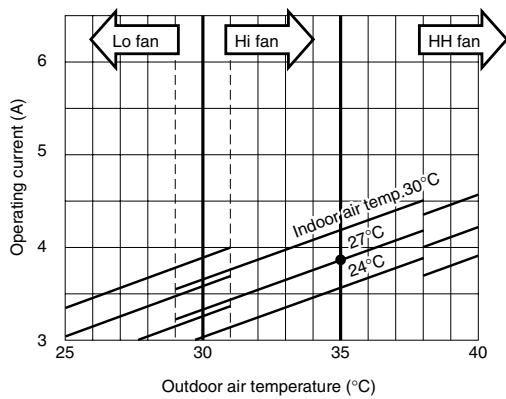

(3) Indoor discharge air performance chart

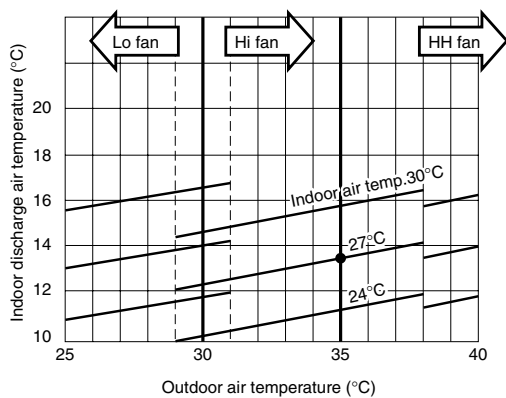

■ **Heating Characteristics**

(RH : 85%, Indoor fan speed : High fan)
(230V, 50Hz)

(1) High pressure performance chart

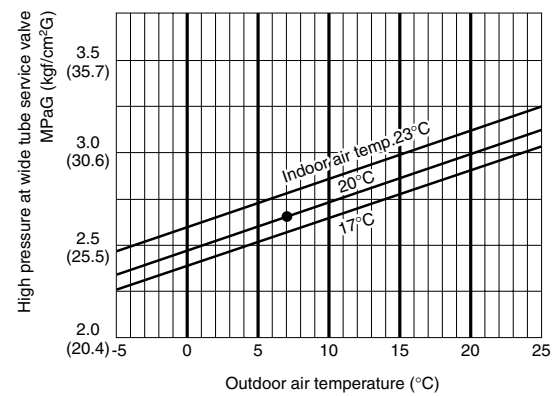

(2) Operating current performance chart

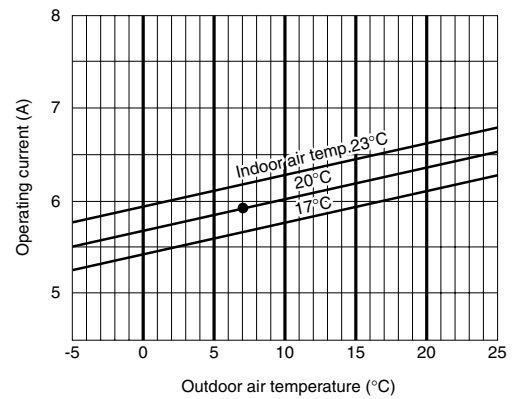

(3) Indoor discharge air performance chart

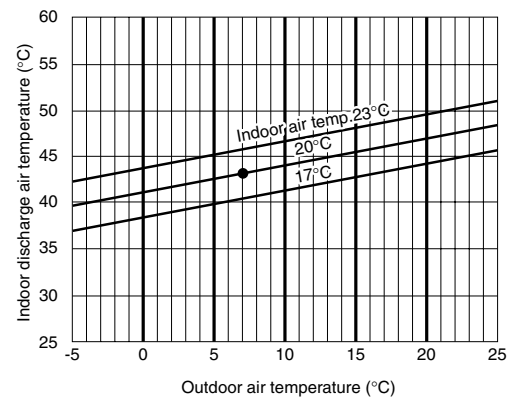

NOTE

- This performance chart shows operation of a single wall-mounted indoor unit. The performance chart will vary depending on the indoor unit type.
- Check each performance value in test-run mode. Electrical performance values represent a combined indoor/outdoor value. (In this case, be sure to stop all the indoor units where performance is not being checked.)
- The performance is for a tubing length of 7.5 m. If the tubing length is different, the performance chart will vary.

Outdoor Unit **AE3MI68AH** Indoor Unit **AWMI35AHL** × 1

■ **Cooling Characteristics**

(RH : 46%, Indoor fan speed : High fan)
(230V, 50Hz)

(1) Low pressure performance chart

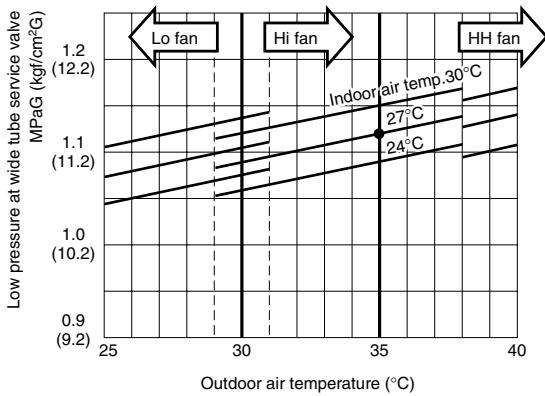

(2) Operating current performance chart

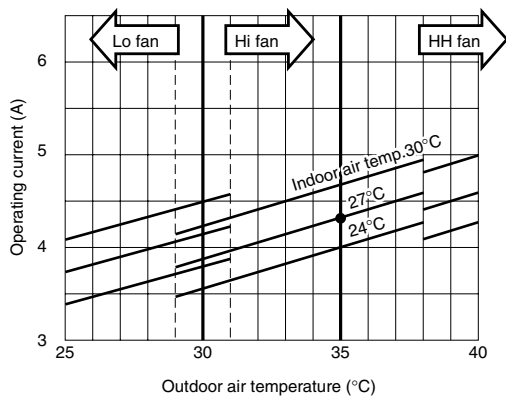

(3) Indoor discharge air performance chart

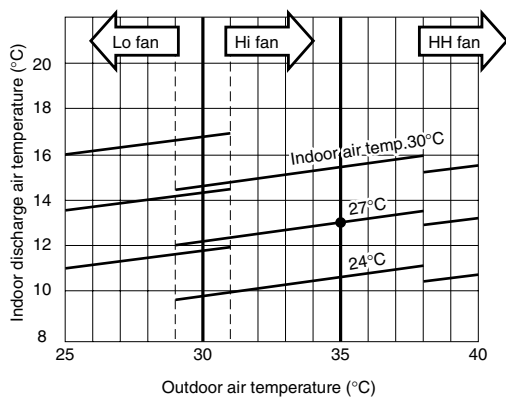

■ **Heating Characteristics**

(RH : 85%, Indoor fan speed : High fan)
(230V, 50Hz)

(1) High pressure performance chart

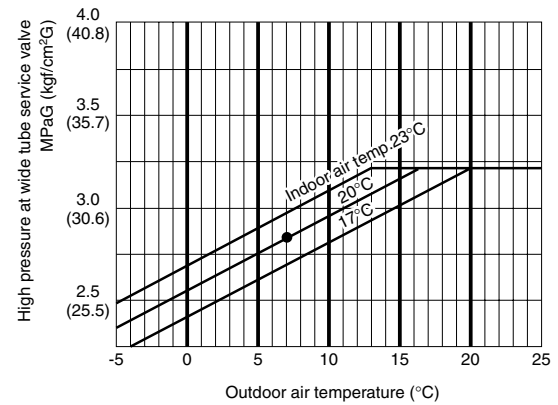

(2) Operating current performance chart

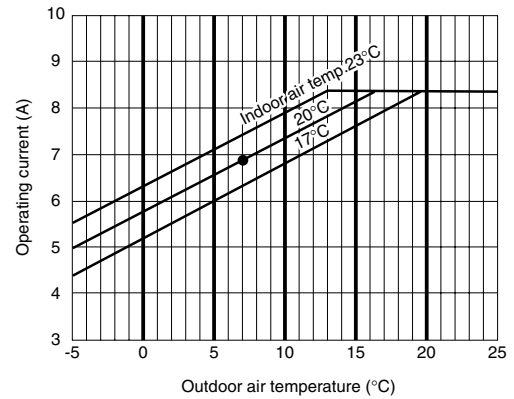

(3) Indoor discharge air performance chart

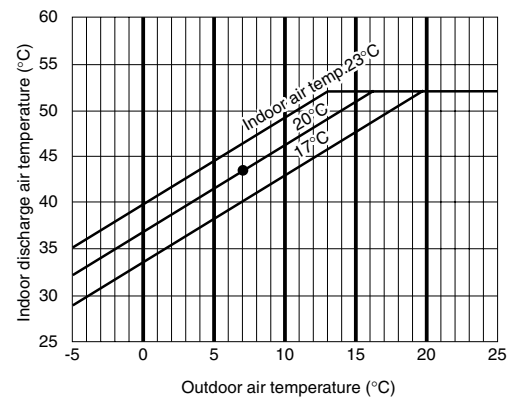

NOTE

- This performance chart shows operation of a single wall-mounted indoor unit. The performance chart will vary depending on the indoor unit type.
- Check each performance value in test-run mode. Electrical performance values represent a combined indoor/outdoor value. (In this case, be sure to stop all the indoor units where performance is not being checked.)
- The performance is for a tubing length of 7.5 m. If the tubing length is different, the performance chart will vary.

Outdoor Unit **AE3MI68AH** Indoor Unit **AWI52AHL × 1**

■ Cooling Characteristics

(RH : 46%, Indoor fan speed : High fan)
(230V, 50Hz)

(1) Low pressure performance chart

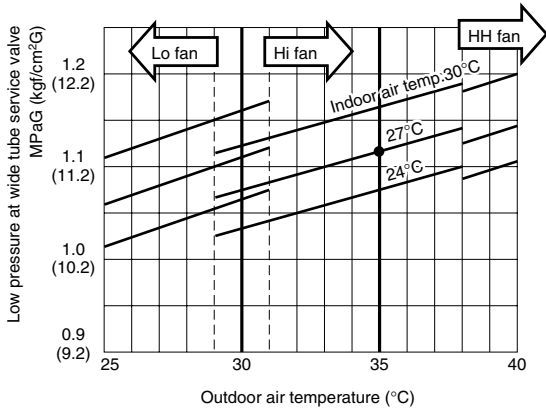

(2) Operating current performance chart

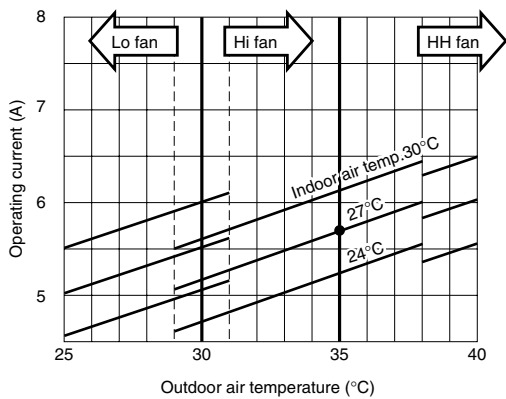

(3) Indoor discharge air performance chart

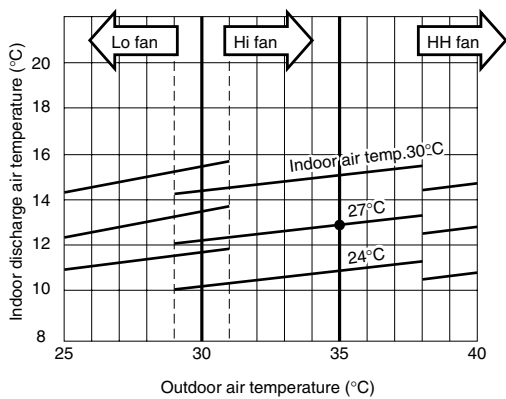

■ Heating Characteristics

(RH : 85%, Indoor fan speed : High fan)
(230V, 50Hz)

(1) High pressure performance chart

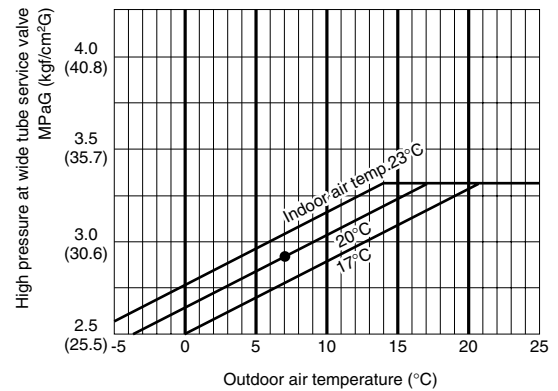

(2) Operating current performance chart

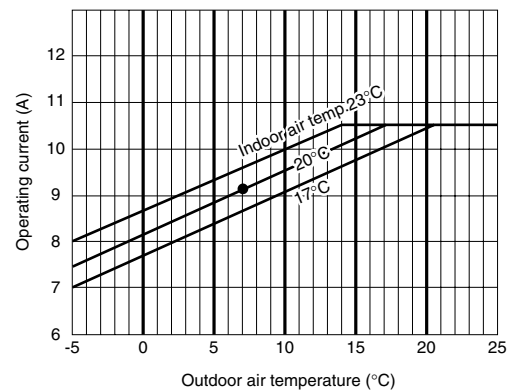

(3) Indoor discharge air performance chart

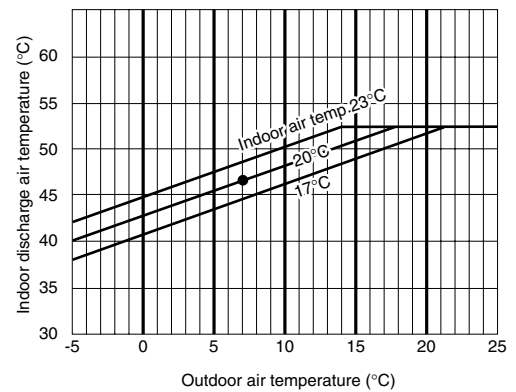

NOTE

- This performance chart shows operation of a single wall-mounted indoor unit. The performance chart will vary depending on the indoor unit type.
- Check each performance value in test-run mode. Electrical performance values represent a combined indoor/outdoor value. (In this case, be sure to stop all the indoor units where performance is not being checked.)
- The performance is for a tubing length of 7.5 m. If the tubing length is different, the performance chart will vary.

Outdoor Unit **AE3MI68AH** Indoor Unit **AWI68AHL × 1**

■ Cooling Characteristics

(RH : 46%, Indoor fan speed : High fan)
(230V, 50Hz)

(1) Low pressure performance chart

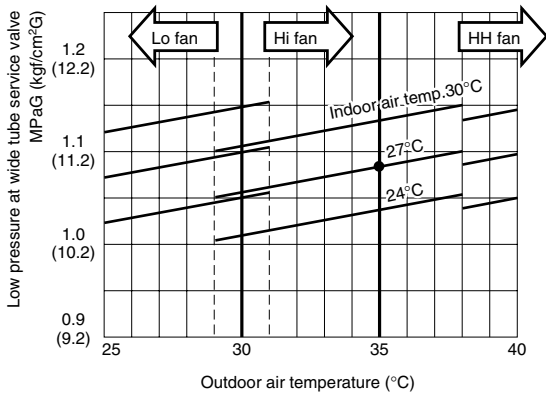

(2) Operating current performance chart

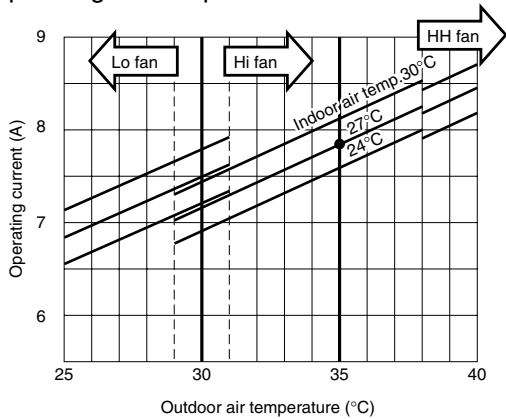

(3) Indoor discharge air performance chart

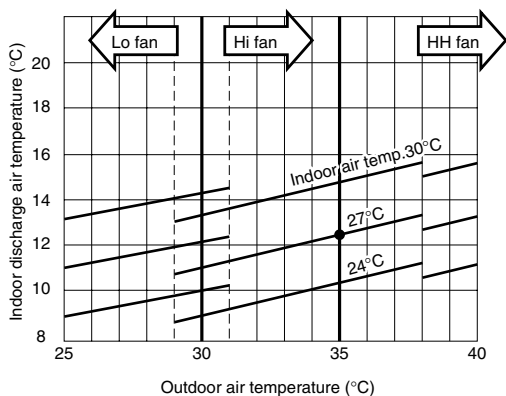

■ Heating Characteristics

(RH : 85%, Indoor fan speed : High fan)
(230V, 50Hz)

(1) High pressure performance chart

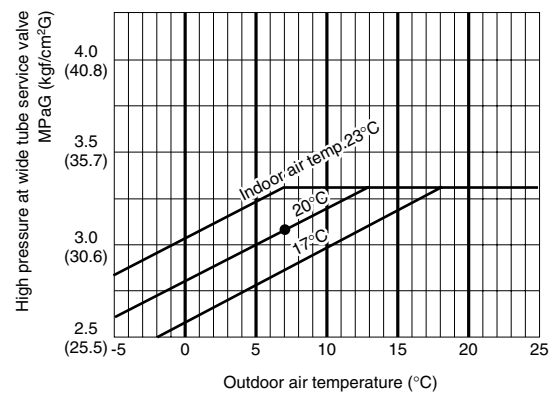

(2) Operating current performance chart

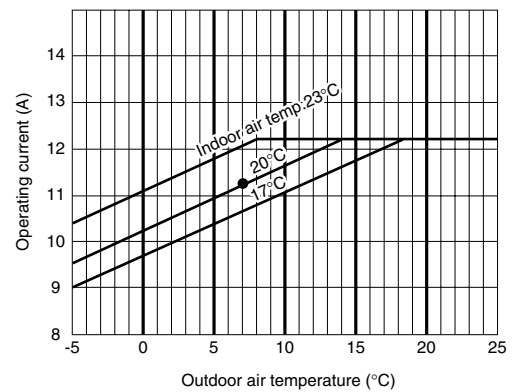

(3) Indoor discharge air performance chart

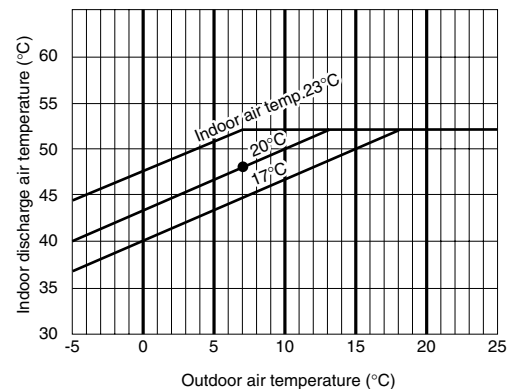

NOTE

- This performance chart shows operation of a single wall-mounted indoor unit. The performance chart will vary depending on the indoor unit type.
- Check each performance value in test-run mode. Electrical performance values represent a combined indoor/outdoor value. (In this case, be sure to stop all the indoor units where performance is not being checked.)
- The performance is for a tubing length of 7.5 m. If the tubing length is different, the performance chart will vary.

5-1-4. Temperature Charts (AE4MI80AH)

Outdoor Unit **AE4MI80AH** Indoor Unit **AWMI22AHL** × 1

■ Cooling Characteristics

(RH : 46%, Indoor fan speed : High fan)
(230V, 50Hz)

(1) Low pressure performance chart

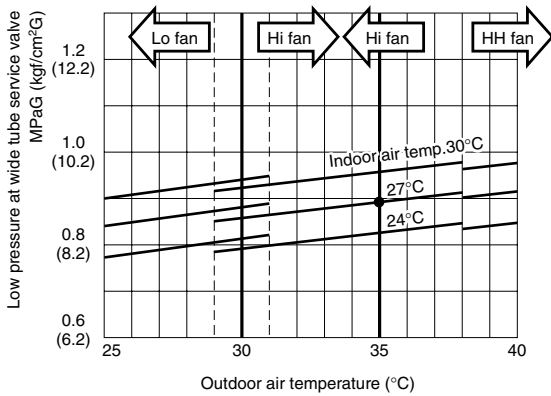

(2) Operating current performance chart

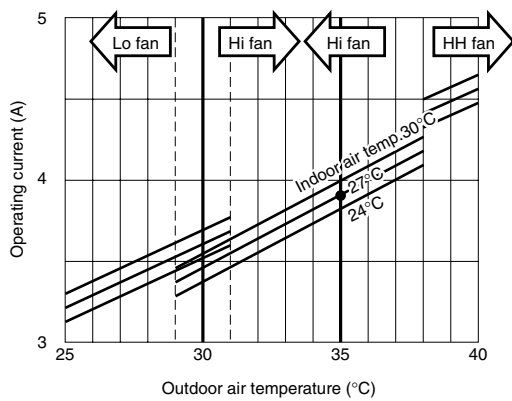

(3) Indoor discharge air performance chart

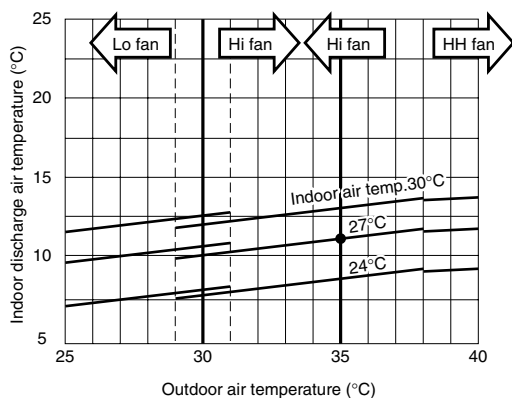

■ Heating Characteristics

(RH : 85%, Indoor fan speed : High fan)
(230V, 50Hz)

(1) High pressure performance chart

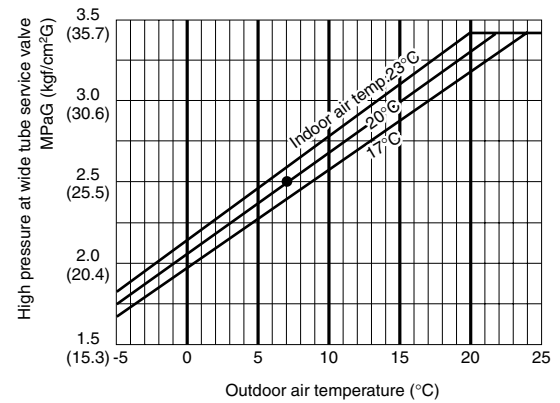

(2) Operating current performance chart

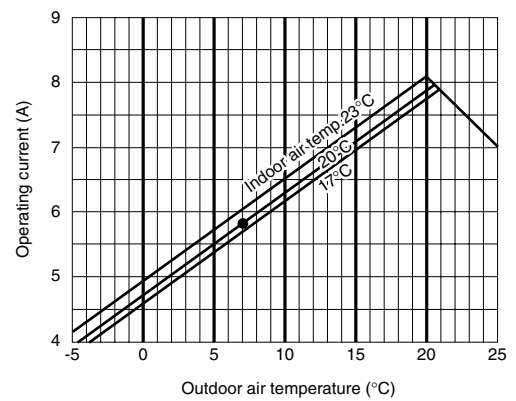

(3) Indoor discharge air performance chart

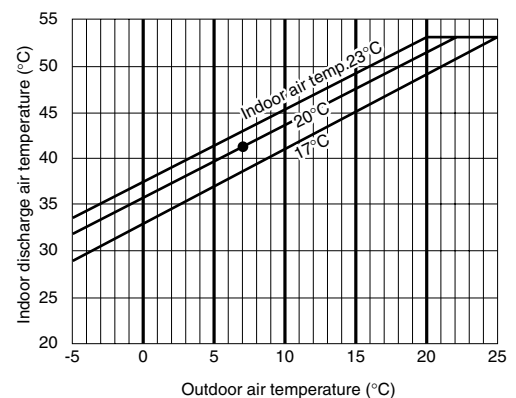

NOTE

- This performance chart shows operation of a single wall-mounted indoor unit. The performance chart will vary depending on the indoor unit type.
- Check each performance value in test-run mode. Electrical performance values represent a combined indoor/outdoor value. (In this case, be sure to stop all the indoor units where performance is not being checked.)
- The performance is for a tubing length of 7.5 m. If the tubing length is different, the performance chart will vary.

Outdoor Unit **AE4MI80AH** Indoor Unit **AWMI27AHL** × 1

■ Cooling Characteristics

(RH : 46%, Indoor fan speed : High fan)
(230V, 50Hz)

(1) Low pressure performance chart

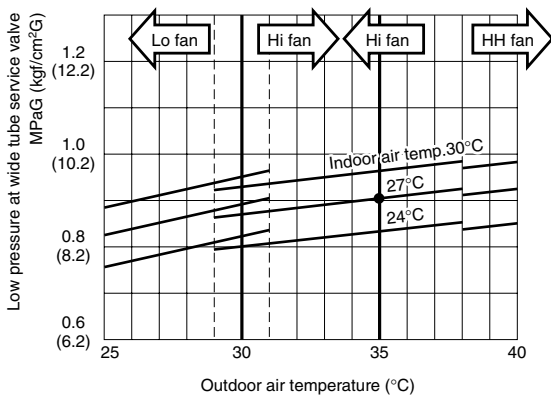

(2) Operating current performance chart

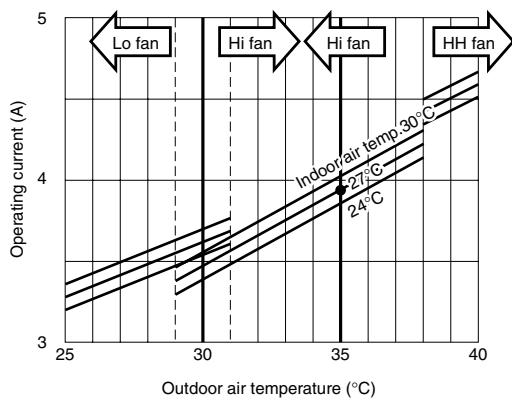

(3) Indoor discharge air performance chart

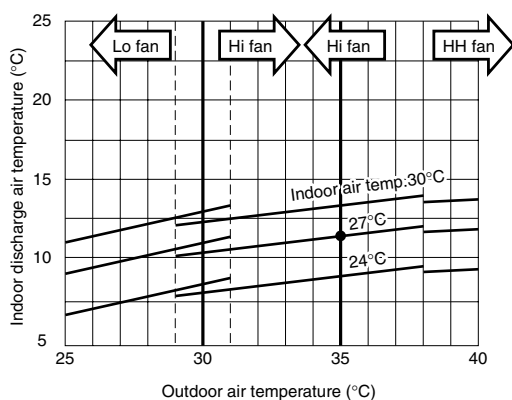

■ Heating Characteristics

(RH : 85%, Indoor fan speed : High fan)
(230V, 50Hz)

(1) High pressure performance chart

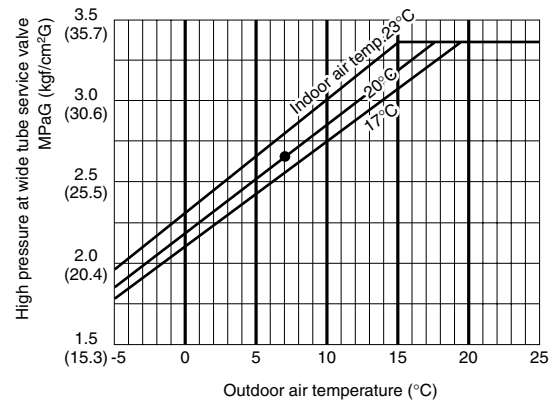

(2) Operating current performance chart

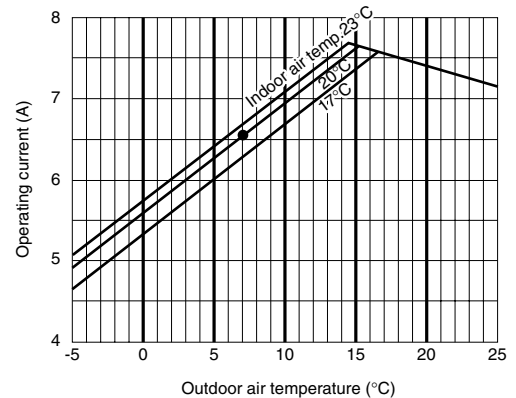

(3) Indoor discharge air performance chart

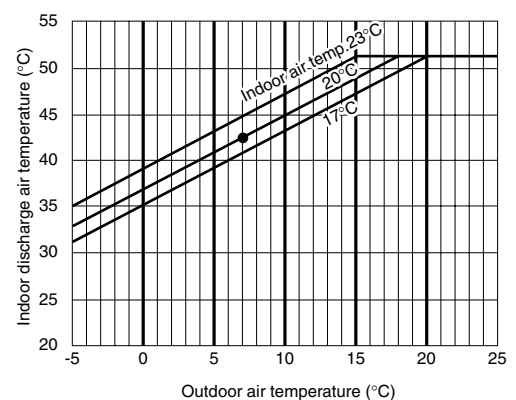

NOTE

- This performance chart shows operation of a single wall-mounted indoor unit. The performance chart will vary depending on the indoor unit type.
- Check each performance value in test-run mode. Electrical performance values represent a combined indoor/outdoor value. (In this case, be sure to stop all the indoor units where performance is not being checked.)
- The performance is for a tubing length of 7.5 m. If the tubing length is different, the performance chart will vary.

Outdoor Unit **AE4MI80AH** Indoor Unit **AWMI35AHL × 1**

■ **Cooling Characteristics**

(RH : 46%, Indoor fan speed : High fan)
(230V, 50Hz)

(1) Low pressure performance chart

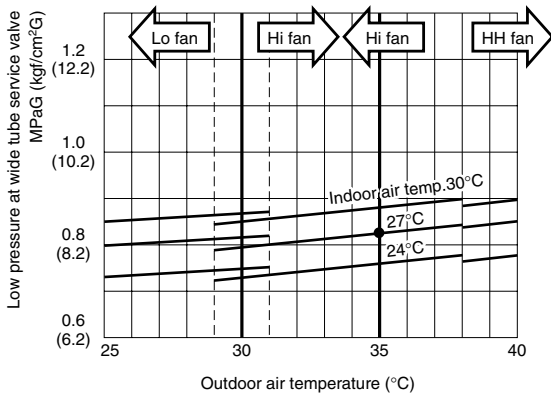

(2) Operating current performance chart

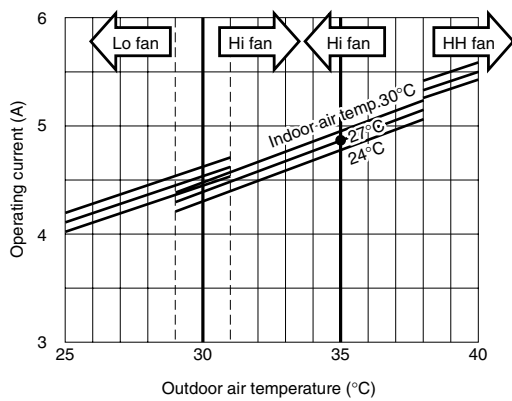

(3) Indoor discharge air performance chart

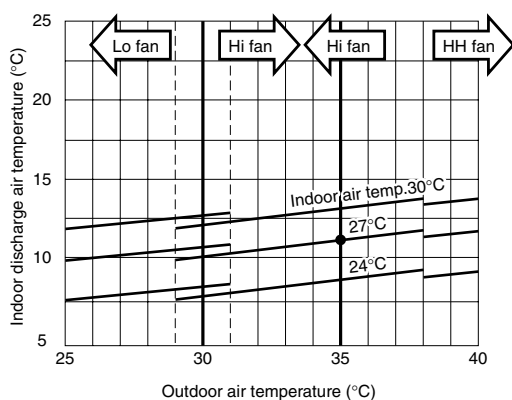

■ **Heating Characteristics**

(RH : 85%, Indoor fan speed : High fan)
(230V, 50Hz)

(1) High pressure performance chart

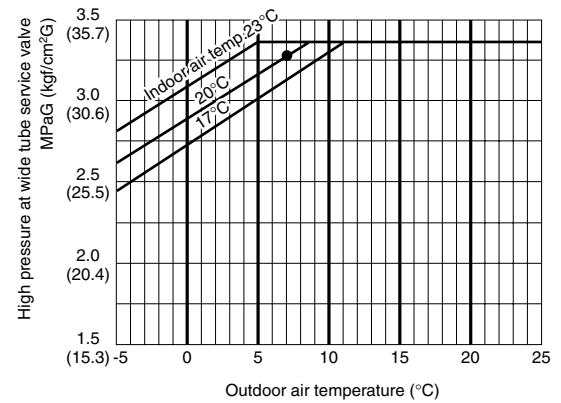

(2) Operating current performance chart

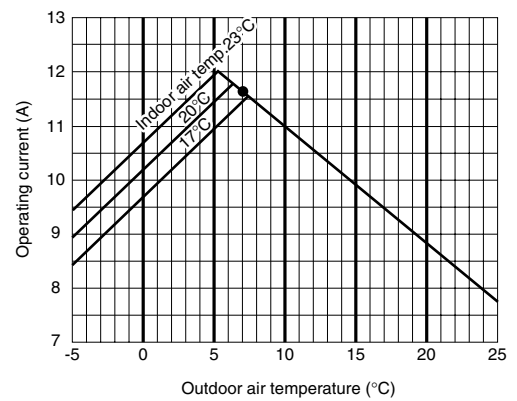

(3) Indoor discharge air performance chart

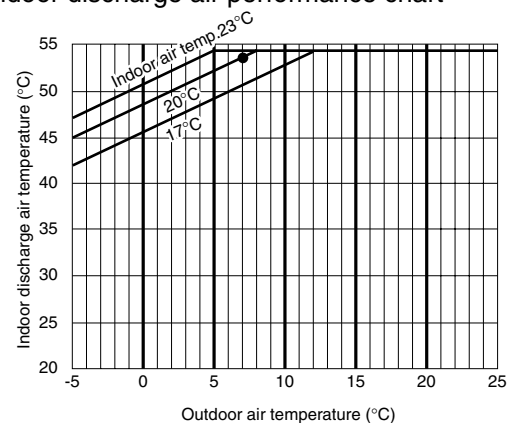

NOTE

- This performance chart shows operation of a single wall-mounted indoor unit. The performance chart will vary depending on the indoor unit type.
- Check each performance value in test-run mode. Electrical performance values represent a combined indoor/outdoor value. (In this case, be sure to stop all the indoor units where performance is not being checked.)
- The performance is for a tubing length of 7.5 m. If the tubing length is different, the performance chart will vary.

Outdoor Unit **AE4MI80AH** Indoor Unit **AWI52AHL** × 1

■ **Cooling Characteristics**

(RH : 46%, Indoor fan speed : High fan)
(230V, 50Hz)

(1) Low pressure performance chart

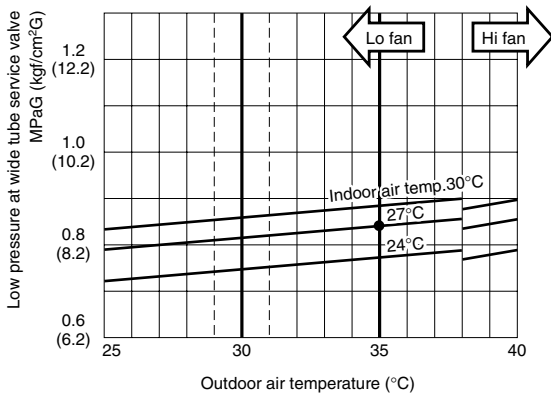

(2) Operating current performance chart

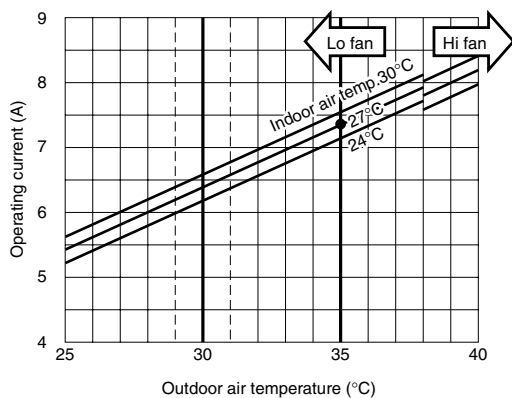

(3) Indoor discharge air performance chart

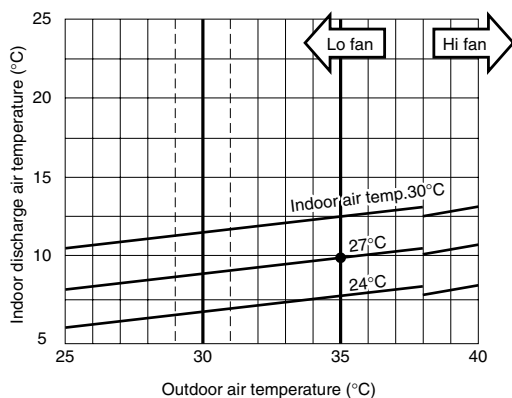

■ **Heating Characteristics**

(RH : 85%, Indoor fan speed : High fan)
(230V, 50Hz)

(1) High pressure performance chart

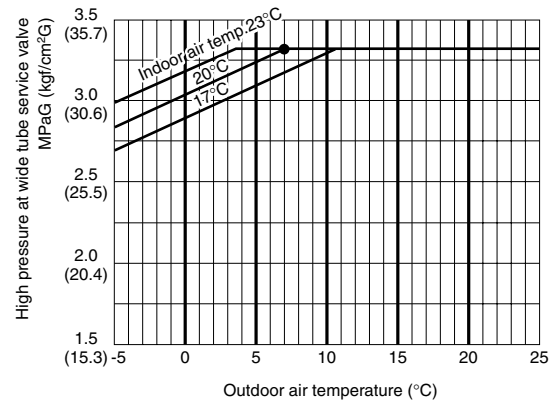

(2) Operating current performance chart

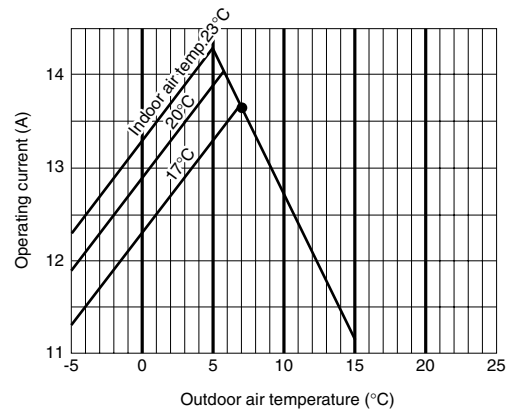

(3) Indoor discharge air performance chart

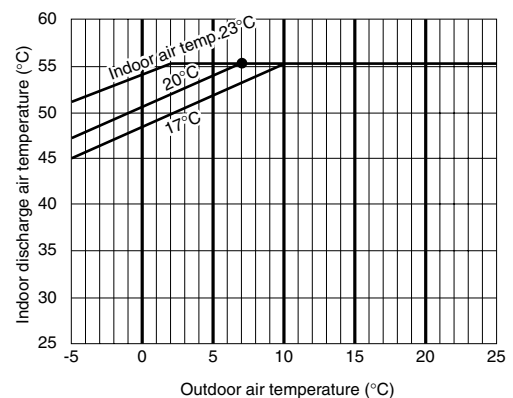

NOTE

- This performance chart shows operation of a single wall-mounted indoor unit. The performance chart will vary depending on the indoor unit type.
- Check each performance value in test-run mode. Electrical performance values represent a combined indoor/outdoor value. (In this case, be sure to stop all the indoor units where performance is not being checked.)
- The performance is for a tubing length of 7.5 m. If the tubing length is different, the performance chart will vary.

Outdoor Unit **AE4MI80AH** Indoor Unit **AWI68AHL** × 1

■ Cooling Characteristics

(RH : 46%, Indoor fan speed : High fan)
(230V, 50Hz)

(1) Low pressure performance chart

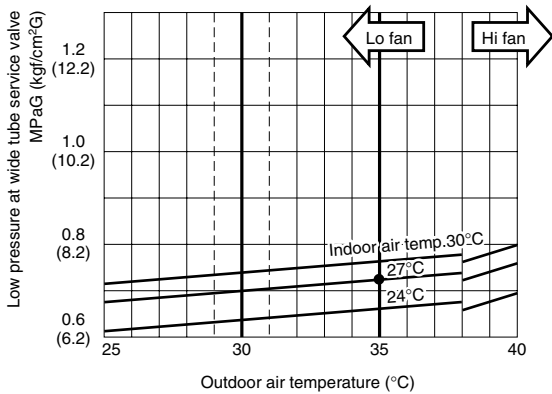

(2) Operating current performance chart

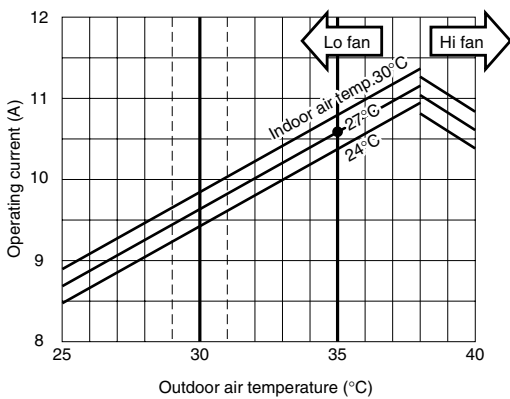

(3) Indoor discharge air performance chart

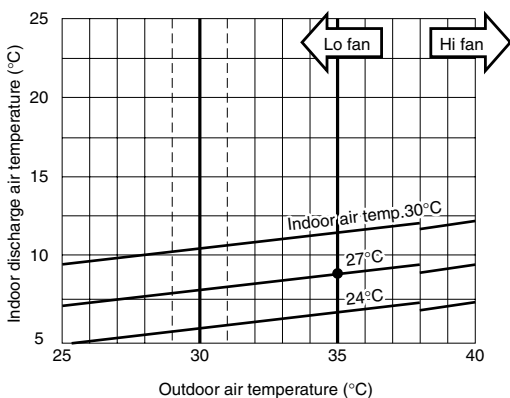

■ Heating Characteristics

(RH : 85%, Indoor fan speed : High fan)
(230V, 50Hz)

(1) High pressure performance chart

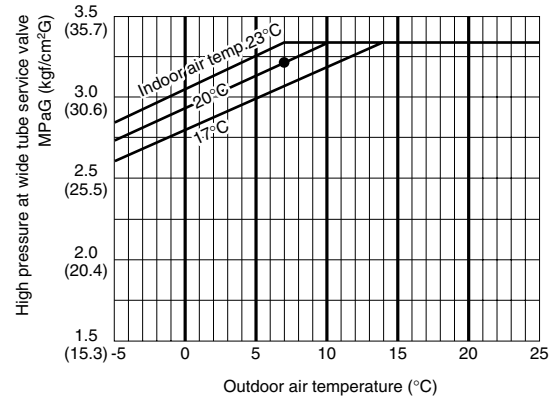

(2) Operating current performance chart

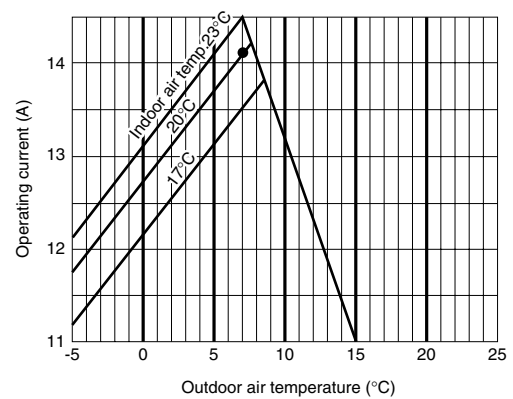

(3) Indoor discharge air performance chart

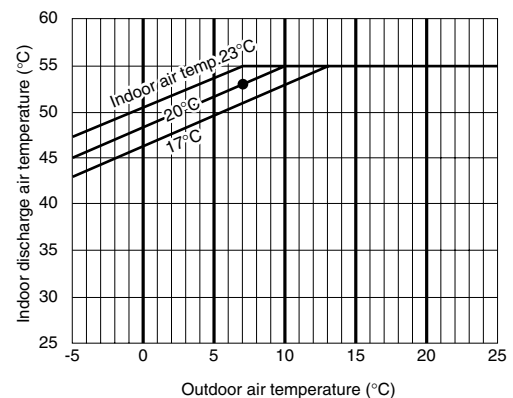

NOTE

- This performance chart shows operation of a single wall-mounted indoor unit. The performance chart will vary depending on the indoor unit type.
- Check each performance value in test-run mode. Electrical performance values represent a combined indoor/outdoor value. (In this case, be sure to stop all the indoor units where performance is not being checked.)
- The performance is for a tubing length of 7.5 m. If the tubing length is different, the performance chart will vary.

6. ELECTRICAL DATA

6-1. Electric Wiring Diagrams

Outdoor Unit AE2MI40AH



WARNING

To avoid electrical shock hazard, be sure to disconnect power before checking, servicing and/or cleaning any electrical parts.

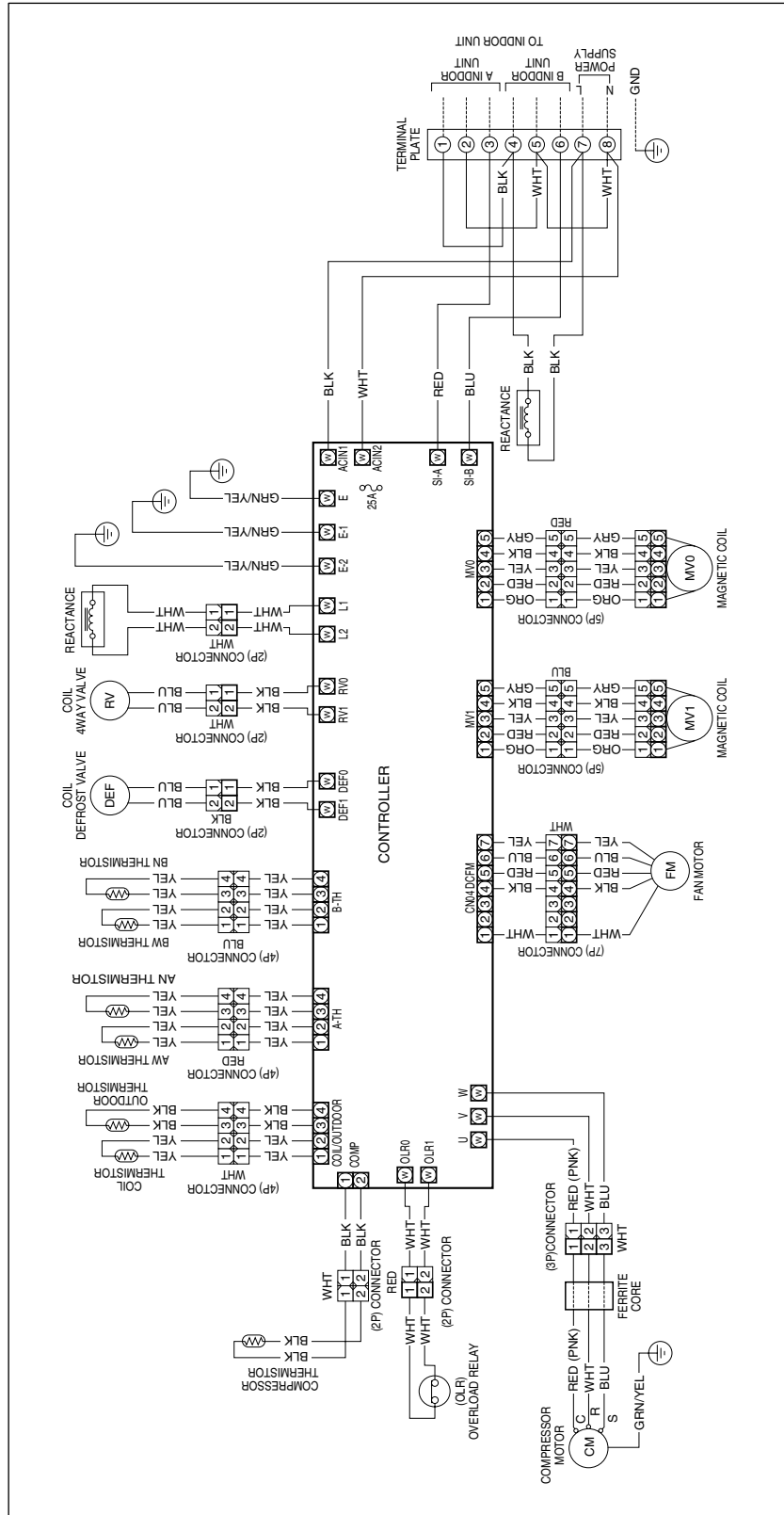

8FA2-5257-56900-2



WARNING

To avoid electrical shock hazard, be sure to disconnect power before checking, servicing and/or cleaning any electrical parts.

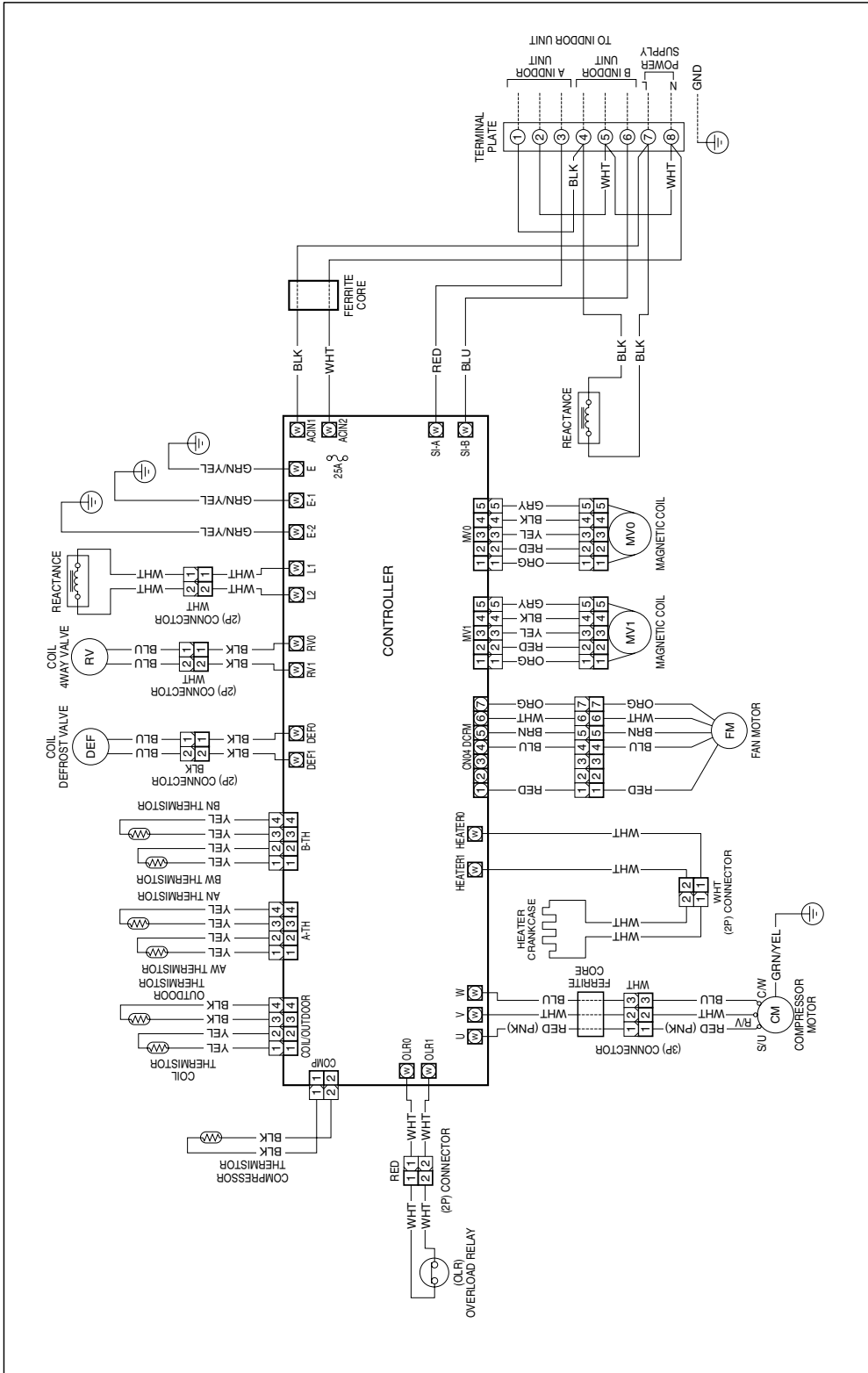

8FA2-5257-84200-0



WARNING

To avoid electrical shock hazard, be sure to disconnect power before checking, servicing and/or cleaning any electrical parts.

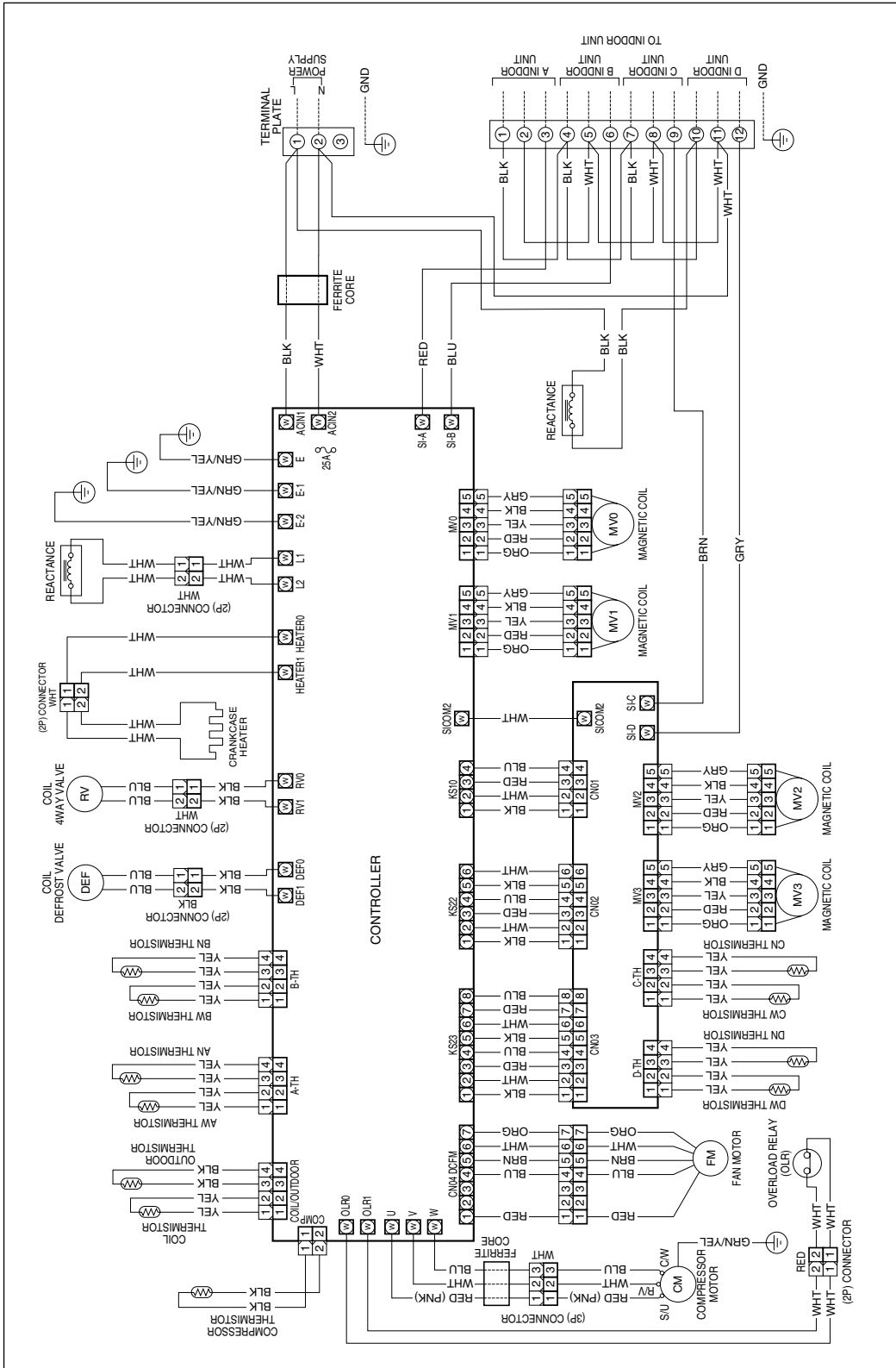

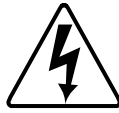

WARNING

To avoid electrical shock hazard, be sure to disconnect power before checking, servicing and/or cleaning any electrical parts.

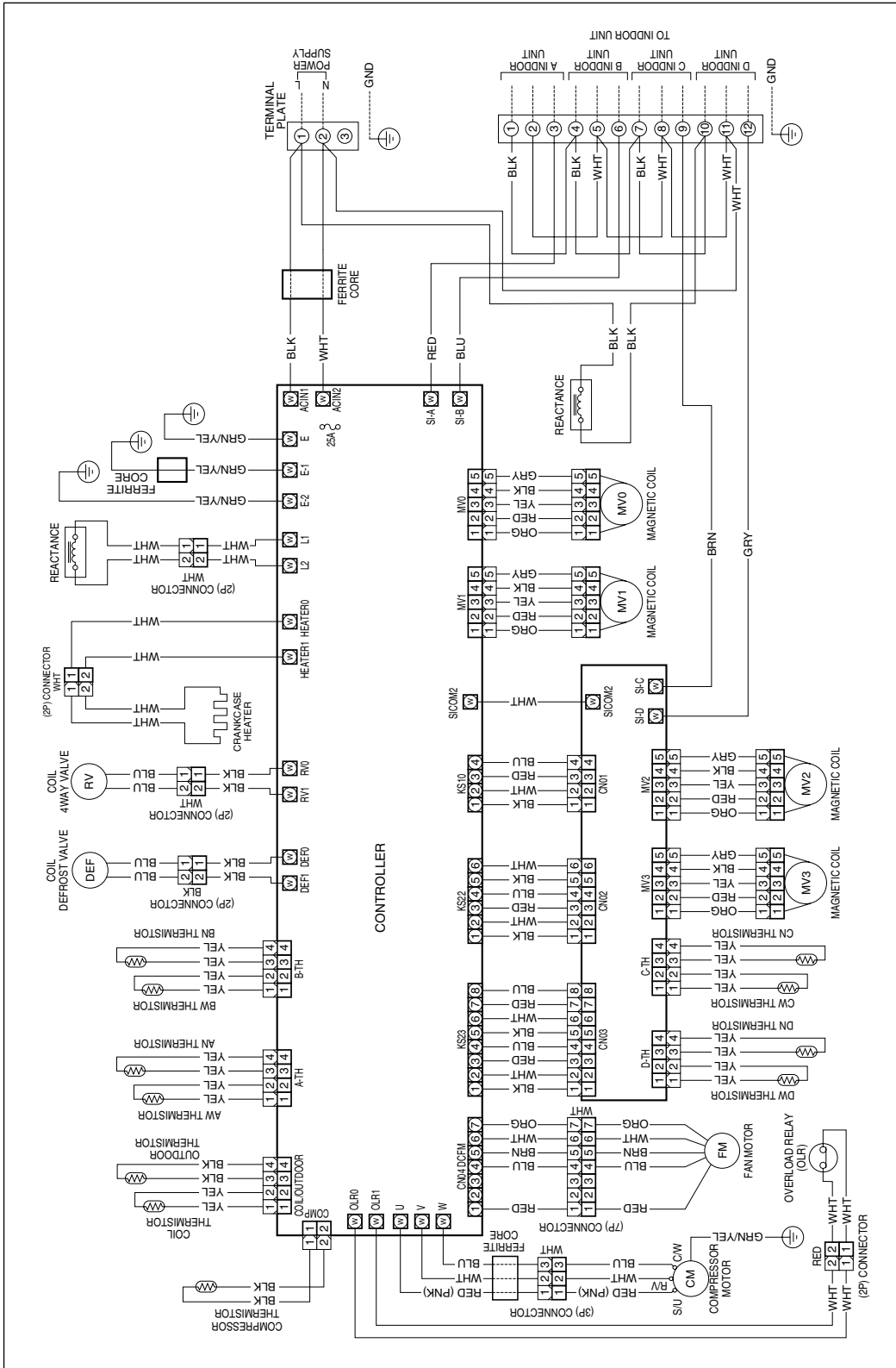

7. FUNCTIONS

7-1. Explanation of Functions

NOTE The numerical values such as temperature, frequency, time and current in parentheses are an example of AE4MI80AH and the values are different from the other models.

	Control/conditions	Unit operation	Explanation
INITIAL	Breaker is ON.	_____	Power is supplied to the indoor and outdoor unit control circuits, however the unit remains stopped. Positioning of the outdoor unit electric expansion valve is performed.
	The ON/OFF operation button on the remote controller is pressed.	If automatic operation mode has been selected with the remote controller, operation begins in HEAT, SENSOR DRY, or COOL mode depending on the room temperature and outdoor temperature at the time operation starts.	● This applies in the case of automatic HEAT/COOL operation.
	 Depending on the operational mode, refer to the HEAT, SENSOR DRY, or COOL item.		
HEAT	The ON/OFF operation button on the remote controller is pressed.	<ul style="list-style-type: none"> ● Operation lamp illuminates. ● Indoor fan is stopped to prevent cold air from being emitted. ● Outdoor unit begins operating after forced-stop is canceled. 	<ul style="list-style-type: none"> ● The unit is forced to stop for 3 minutes after the power is turned ON, or 3 minutes after the compressor stops, in order to protect the compressor. The frequency is increased at the rate of 1 Hz every 0.5 seconds.
		<ul style="list-style-type: none"> ● When the indoor coil temperature rises, <ul style="list-style-type: none"> – the compressor starts, – the outdoor fan starts, – and the indoor fan changes from "LL" to the set fan speed. 	<ul style="list-style-type: none"> ● Depending on the relationship between the remote controller temperature setting and the room temperature, the compressor may stop temporarily (in other words, the thermostat may turn OFF).
		When the frequency reaches α Hz, frequency increases are stopped for a period of β seconds. (Refer to Table 2 "Frequency control".)	This is in order to stabilize the return of oil to the compressor.
		The frequency then increases.	If the indoor and outdoor temperatures are high, the current peak cut-off activates, stopping any increases in frequency.
	The room temperature has reached the desired temperature.	<ul style="list-style-type: none"> ● The indoor temperature and the remote controller temperature setting are approximately equal. 	Operating frequency is stabilized in order to maintain a comfortable environment.
	The thermostat turns OFF.	<ul style="list-style-type: none"> ● The indoor fan is stopped. 	<ul style="list-style-type: none"> ● The outdoor unit stops. (It does not stop if the thermostat for another indoor unit is ON.) ● Approximately 30 seconds after the thermostat turns OFF, the indoor fan is stopped.
	The indoor and outdoor temperatures are high.	In order to protect the compressor, the outdoor unit will not operate for 3 minutes after the thermostat turns OFF, even if the room temperature drops below the desired temperature.	<ul style="list-style-type: none"> ● The outdoor unit starts automatically after 3 minutes. ● During these 3 minutes, a low-pressure pressure balance is achieved, allowing the compressor to start more easily.
		<ul style="list-style-type: none"> ● The frequency is not increased, even if there is a difference between the room temperature and the desired temperature. In some cases, the frequency may be decreased. 	<ul style="list-style-type: none"> ● The amount of heat pump exceeds the amount of heat radiation from the room. Therefore, there is no need to further increase the compressor capacity, and the frequency is stabilized or lowered.
	The thermostat turns ON.	<ul style="list-style-type: none"> ● The indoor unit is stopped. 	The unit operated before, and the temperature of the indoor heat exchanger is relatively warm. Therefore, the fan speed may start at the set fan speed at the same time that the thermostat turns ON.

	Control/conditions	Unit operation	Explanation
HEAT	When defrost operation begins, frost has formed on the outdoor unit (when the ambient air temperature is low).	Non-stop defrost <ul style="list-style-type: none"> ● Indoor fan : Stopped ● Outdoor fan : Stopped ● Compressor : 80 Hz ● Solenoid valve (for hot gas bypass): ON ● 4-way valve : Remains ON ● Operation lamp : Red and orange ON alternately 	Defrost operation begins based on outdoor heat exchanger temperature and outdoor air temperature conditions. Non-stop defrost (Refer to Fig. 1) 1. After HEAT operation begins, the temperature of the outdoor heat exchanger is at or below the L1 line for 35 minutes. (If outdoor air temperature is less than -3°C , the time is 48 minutes) 2. After HEAT operation begins, the temperature of the outdoor heat exchanger is at or below the L2 line for 120 minutes.
			The 4-way valve remains ON during defrost.
			<ul style="list-style-type: none"> ● The outdoor fan stops and the solenoid valve turns ON, allowing the refrigerant to bypass the indoor unit.
			<ul style="list-style-type: none"> ● The operating frequency during defrost is 80 Hz. (Frequency is lowered if the current peak cut-off function is activated.)
			<ul style="list-style-type: none"> ● The maximum length of a single defrost operation is 12 minutes. ● For the outdoor heat exchanger temperature conditions for ending defrost, refer to Table 1.
	Defrost release	<ul style="list-style-type: none"> ● Indoor fan turns ON. ● After 10 seconds, the solenoid valve (for hot gas bypass) turns OFF. <p style="text-align: center;">↓</p> <ul style="list-style-type: none"> ● When the cold air feel has disappeared, the indoor fan starts and gradually increases speed until it reaches the set speed. 	_____
	STOP [Clean defrost] Defrost is performed when the outdoor unit is stopped, and the temperature of the outdoor unit coil is at or below the L1 line. (Refer to Fig. 1.)	All indicator lamps turn OFF. The indoor and outdoor units stop.	_____
	Operation is restarted within 4 hours (only when AUTO mode is selected with the remote controller).	Starts operating in the same operating mode (HEAT) and with the same temperature settings as before operation was stopped.	Within 4 hours after operation was stopped, it is assumed that there has been no significant change in the indoor and outdoor temperatures, and the previous conditions (HEAT) are stored.
	Operation starts after 4 hours or more have passed.	New operation begins based on the temperature conditions at the time the ON/OFF button is pressed.	_____

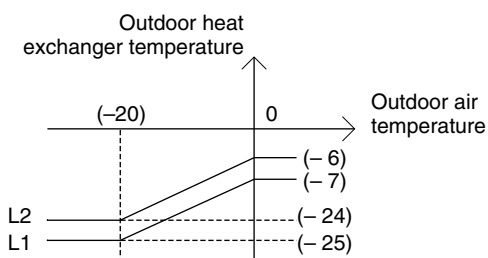

Fig. 1

Temperature of releasing

Defrost operation time	Less than 2 minutes	2 minutes or more
Heat exchanger temperature for releasing defrosting	No releasing	14°C or higher (*1)

*1 The temperature for releasing of defrosting is (20°C) or higher when the outdoor air temperature is less than 0°C .

Table 1



	Control/conditions	Unit operation	Explanation
COOL	The ON/OFF operation button on the remote controller is pressed.	<ul style="list-style-type: none"> The operation lamp illuminates. The indoor fan operates at the set fan speed. The outdoor unit stops. 	The outdoor unit does not operate for 3 minutes even after the breaker is turned ON.
		The outdoor unit starts. (Compressor and the outdoor fan start.)	<ul style="list-style-type: none"> The frequency is increased at the rate of 0.5 Hz every 1 seconds.
		When the frequency reaches α Hz, frequency increases are stopped for a period of β seconds. (Refer to Table 2.)	This is in order to stabilize the return of oil to the compressor.
		The frequency then increases.	If the indoor and outdoor temperatures are high, the current peak cut-off activates, stopping any increases in frequency.
	The room temperature has reached the desired temperature.	The indoor temperature and the desired temperature are approximately equal.	Operating frequency is stabilized in order to maintain a comfortable environment.
	The thermostat turns OFF.	_____	The outdoor unit stops. (It does not stop if the thermostat for another indoor unit is ON.)
	The thermostat turns ON again.	After the thermostat turns ON again, the outdoor unit will not operate for 3 minutes, even if the room temperature increases above the desired temperature.	After 3 minutes, the outdoor unit begins operating automatically. During these 3 minutes, a pressure balance is achieved, allowing the compressor to start more easily.
	Freeze prevention	<ul style="list-style-type: none"> When the temperature of the indoor heat exchanger drops to approximately 2 °C or below, the compressor turns OFF, the outdoor fan turns OFF, and the indoor fan continues operating with no changes. <div style="text-align: center;">↓</div> <ul style="list-style-type: none"> Approximately 3 minutes later, if the temperature of the indoor heat exchanger is above 8 °C, the system returns to its original conditions. 	In order to protect against freezing, the compressor stops temporarily, until the temperature of the indoor heat exchanger has risen.
Stop	All indicator lamps turn OFF. The indoor and outdoor units stop.	_____	
Operation is restarted within 4 hours (only when AUTO mode is selected with the remote controller).	Starts operating in the same operating mode (COOL) and with the same temperature settings as before operation was stopped.	Within 4 hours after operation was stopped, it is assumed that there has been no significant change in the indoor and outdoor temperatures, and the previous conditions (COOL) are stored.	
Operation starts after 4 hours or more have passed.	New operating mode is determined based on the temperature conditions at the time the ON/OFF operation button is pressed.	_____	

Frequency control

α (Hz)	β (seconds)	
	Outdoor air temperature is below 0 °C.	Outdoor air temperature is 0 °C or higher.
(25) Hz	(120) seconds	(60) seconds
(35) Hz	(60) seconds	(30) seconds
(45) Hz	(60) seconds	(30) seconds
(55) Hz	(180) seconds	(90) seconds

Table 2

(1/f fluctuation fan)

	Control/conditions	Unit operation	Explanation
SENSOR DRY	The ON/OFF operation button on the remote controller is pressed.	<ul style="list-style-type: none"> The operation lamp illuminates. The indoor fan operates at the set fan speed. The outdoor unit stops. 	The outdoor unit does not operate for 3 minutes even after the breaker is turned ON.
		The outdoor unit starts. (Compressor and the outdoor fan start.)	<ul style="list-style-type: none"> The frequency is increased at the rate of 0.5 Hz every 1 seconds.
		When the frequency reaches α Hz, frequency increases are stopped for a period of β seconds. (Refer to Table 2.)	This is in order to stabilize the return of oil to the compressor.
		The frequency then increases.	If the indoor and outdoor temperatures are high, the current peak cut-off activates, stopping any increases in frequency.
	The room temperature reaches the desired temperature, and there is no need for further cooling.	<ul style="list-style-type: none"> DRY operation starts DRY A operation <ul style="list-style-type: none"> The indoor fan changes between "Low" and "LL" (very low) over a 6-minute cycle. This is 1/f fluctuation fan operation. (Refer to Fig. 2.) 	Operating frequency is stabilized in order to maintain a comfortable environment. <ul style="list-style-type: none"> Operates to effectively dehumidify the air while not excessively reducing the indoor temperature. The indoor unit operates at 1/f fluctuation fan operation, at a fan speed that does not cause a chilly feeling.
	The room temperature is 15 °C or higher, and is slightly too cold.	DRY B operation <ol style="list-style-type: none"> The indoor fan changes between "Low" and "LL" (very low) over a 6-minute cycle. This is 1/f fluctuation fan operation. <div style="text-align: center;">  </div> After approximately 3 minutes, the compressor turns OFF, the outdoor fan turns OFF, and the indoor fan turns OFF. <div style="text-align: center;">  </div> After approximately 6 minutes, the conditions return to (1). 	The compressor operates on a 3-minutes ON, 6-minutes OFF cycle, to prevent the room temperature from dropping too much.
	The room temperature is below 15 °C.	<ul style="list-style-type: none"> Monitoring operation begins. 	When monitoring operation begins, the compressor stops, and the indoor fan operates at "LL" (very low) speed.

● 1/f fluctuation fan

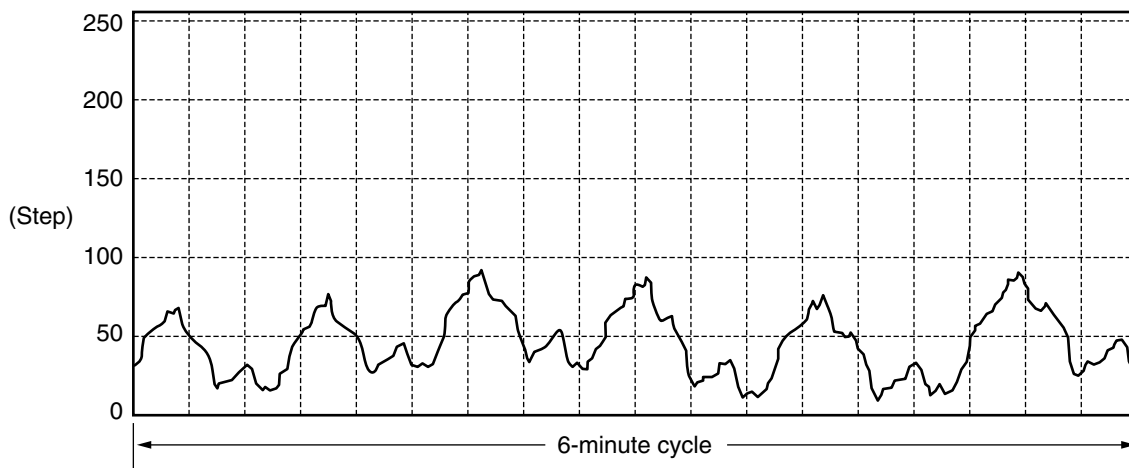

Fig. 2

7-2. Protective Functions

NOTE The numerical values such as temperature, frequency, time and current in parentheses are an example of AE4MI80AH and the values are different from the other models.

7-2-1. Defrost Detection and Release

(1) Non-stop defrosting

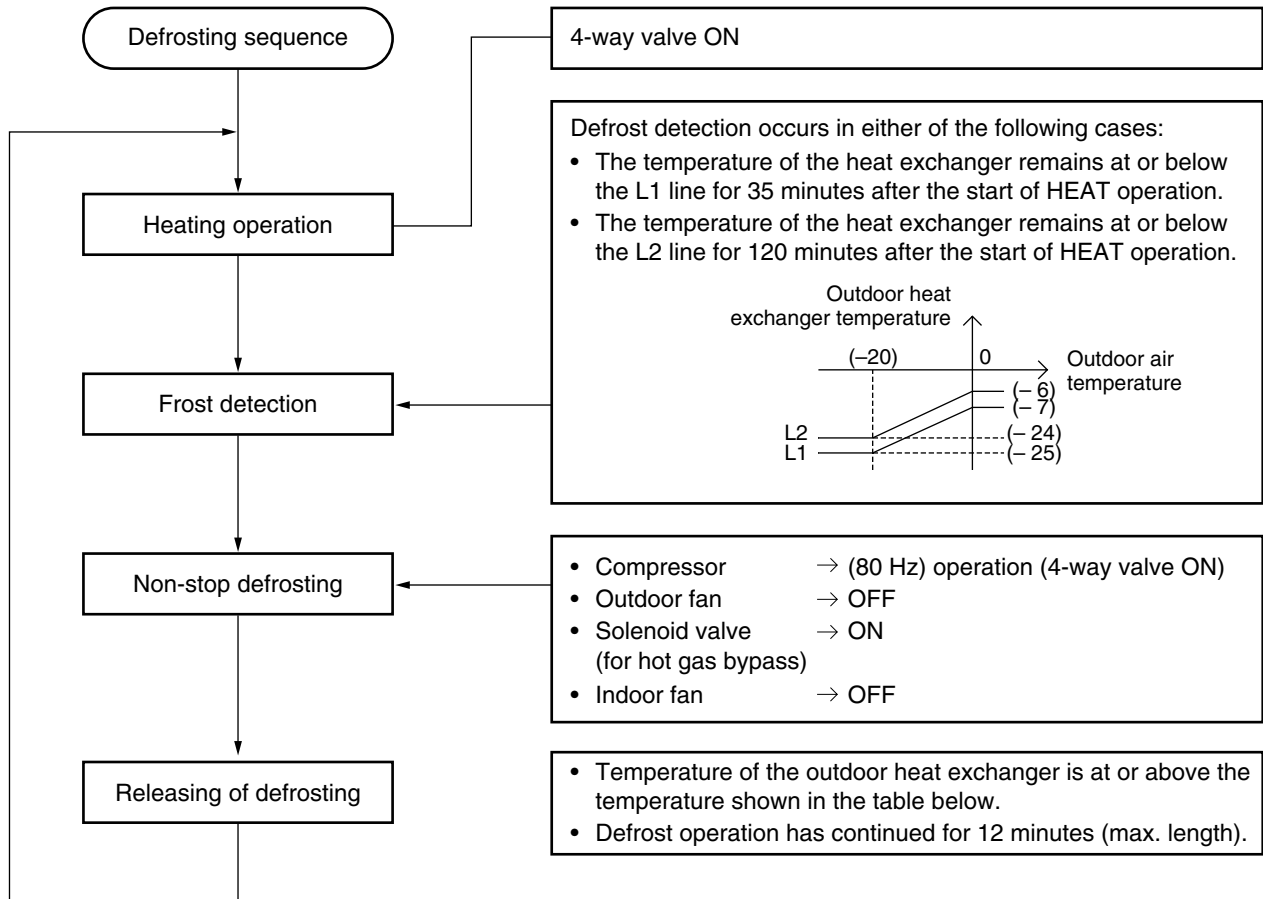

Temperature of releasing

Defrost operation time	Less than 2 minutes	2 minutes or more
Heat exchanger temperature for releasing defrosting	No releasing	14 °C or higher (*1)

*1 The temperature for releasing of defrosting is (20 °C) or higher when the outdoor air temperature is less than 0 °C.

NOTE Defrost does not occur during HIGH POWER operation.

If other stopped indoor units are started during defrost operation, they begin operating in defrost mode.

(2) Clean defrost

If all indoor units are stopped during HEAT operation, and frost is detected at the L1 line, and the conditions for defrost are met, then defrost operation occurs, and the unit stops after defrost is completed.

7-2-2. Current Control

- The operating current may rise as a result of causes including increasing heating or cooling loads or decreases in power voltage. In these cases, the operating frequency is automatically reduced, or operation is stopped, in order to control the operating current so that it is (20 A) or less.

As a result: 

- Power breakers and fuses will not be tripped.
- Operation can continue during this period with somewhat reduced heating or cooling capacity.
- Operation at normal capacity is restored when the cause of the current rise is eliminated.

Description of function

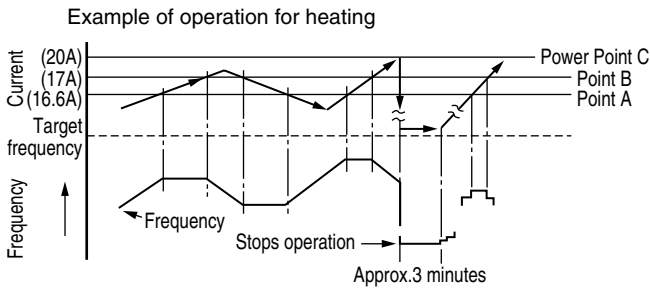

- Operates at the target frequency at Point A and below.
- Stops increases to the frequency between Points A and B.
- Reduces the frequency by 1 Hz per 0.5 seconds when Point B is exceeded.
- Stops operation, and restarts it approximately 3 minutes later, if Point C is exceeded.
(May operate when sudden voltage fluctuations occur. → Indicates trouble.)

(1) Automatic frequency control

The operating frequency is reduced automatically, or operation is stopped, in order to control the operating current so that it is at or below the values shown in the table below.

	(20A)	
	HEAT	COOL
Point C (peak cut trip)	(20.0)	(20.0)
Point B (Hz reduction)	(17.0)	(17.0)
Point A (Hz increase prohibit)	(16.6)	(16.6)

NOTE During defrost operation, the COOL current setting value is used.

(2) Current control

The operating frequency upper limits shown in the figure below are established for frequency reduction and increase-prohibit.

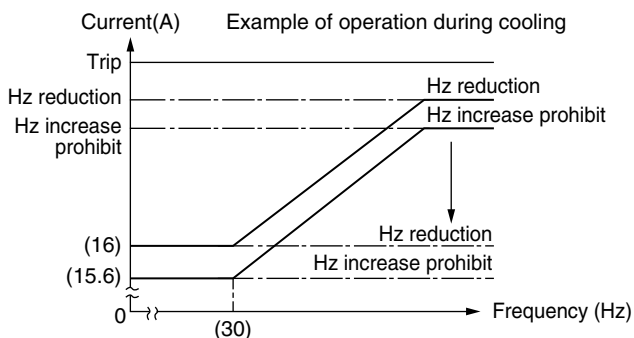

7-2-3. Low Start Current

Operation starts at (8 Hz), and the start current is less than the normal operating current. This prevents the flickering of fluorescent lights or television screens that occurs when ordinary A/C units start.

7-2-4. Compressor Temperature Control

To protect the compressor coil from overheating, the operating frequency is controlled based on the compressor discharge temperature.

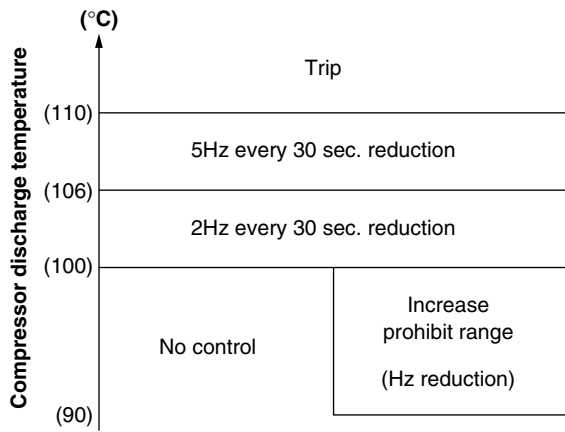

* Within the increase-prohibit range, the range changes to the Hz reduction range (2 Hz every 30 seconds) if the compressor temperature rises by 2 °C.

7-2-5. Control at HEAT Start-up

If HEAT operation is started when the outdoor air temperature is 15 °C or below, the unit operates at the HEAT start-up frequency (70 Hz or above).

Reset conditions

- (1) The compressor frequency exceeds the start-up frequency of (70 Hz).
- (2) The compressor thermostat is OFF.
- (3) Frequency reduction for indoor high-load control has occurred.
- (4) The outdoor air temperature is above 15 °C.
- (5) The main-unit switch on one or more indoor units is set to TEST run.

8. TROUBLESHOOTING

8-1. Precautions before Performing Inspection or Repair

■ **Both the indoor unit and outdoor unit include electronic control circuits.**

Be sure to pay attention to the following before inspecting or repairing the outdoor-side electronic circuits.

- High-capacity electrolytic capacitors are used inside the outdoor unit controller (inverter). They retain an electrical charge (charging voltage DC 311 V) even after the power is turned OFF, and some time is required for the charge to dissipate.

Be careful not to touch any electrified parts before the control circuit board Power Lamp (red) turns OFF.

If the outdoor control circuit board is normal, approximately 180 seconds will be required for the charge to dissipate. However, allow at least 30 minutes for the charge to dissipate if it is thought there might be trouble with the outdoor control circuit board.

For example, if the outdoor control circuit board fuse has blown, approximately 30 minutes will be required to discharge the high-capacity electrolytic capacitors.

8-2. Trouble Diagnosis by Error Monitor Lamps



WARNING

To prevent electric shock, do not inspect or repair until the Power Lamp on the P.C.Board is turned off.

8-2-1. Location of the Error Monitor Lamps

Remove the top plate of outdoor unit and the cover of Electrical Component Box.

The Power Lamp and Error Monitor Lamps are located on the P.C.Board of Electrical Component Box. (Fig.1)

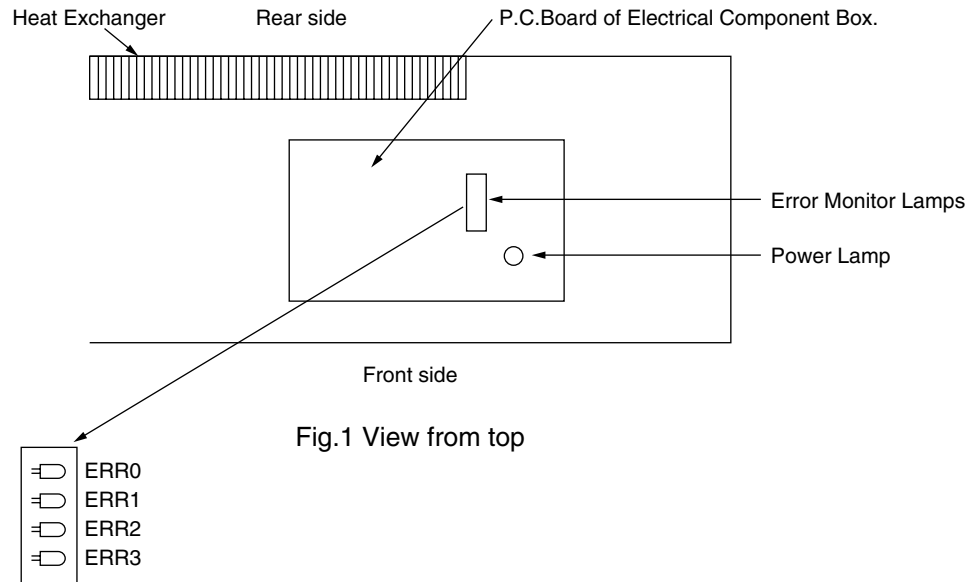

8-2-2. Display of the Error Monitor Lamps

If a protective device has activated or there is a sensor failure in the outdoor unit, the 4 error monitor lamps on the outdoor control circuit board will indicate the nature of the trouble.

○ : ON × : OFF

Error Monitor Lamp				Error Contents
ERR0	ERR1	ERR2	ERR3	
○	×	×	○	Sensor for compressor discharge temp
×	○	×	○	Sensor for heat exchange temp
○	×	×	×	Sensor for branch pipe A (Narrow tube)
×	○	×	×	Sensor for branch pipe B (Narrow tube)
○	○	×	×	Sensor for branch pipe C (Narrow tube)
×	×	○	×	Sensor for branch pipe D (Narrow tube)
○	○	×	○	Outdoor temp sensor
○	×	○	×	Sensor for branch pipe A (Wide tube)
×	○	○	×	Sensor for branch pipe B (Wide tube)
○	○	○	×	Sensor for branch pipe C (Wide tube)
×	×	×	○	Sensor for branch pipe D (Wide tube)
×	×	○	○	HIC circuit trouble (current, temp)
×	○	○	○	Actuation of comp over load relay
○	×	○	○	Actuation of freeze protection function
○	○	○	○	Outdoor unit error. Detail of error message indicate on indoor LED

8-3. Checking the Outdoor System

8-3-1. Checking the outdoor unit

No.	Work procedure	Check items (unit operation)
1	<ul style="list-style-type: none"> Apply 220 V AC between terminals L and N on the outdoor unit terminal plate. 	<ul style="list-style-type: none"> The LED (red) on the control board must illuminate.
2	<ul style="list-style-type: none"> Short-circuit the T-RUN terminal to the COM terminal of TEST/T-RUN terminals. 	<ul style="list-style-type: none"> The compressor, fan motor, 4-way valve, and solenoid valve (for the hot gas bypass) must turn ON. (They turn ON about (70) seconds later after the power is turned ON.)

NOTE If the above check items are okay, but the outdoor unit does not operate, there may be a faulty connection between the indoor unit and the outdoor unit.

8-3-2. Checking the defrost operation

- Using forced defrost operation to check this function.

No.	Work procedure	Check items (unit operation)
1	<ul style="list-style-type: none"> Connect a dummy resistor of 39 k ohm to the outdoor coil temperature sensor connector. 	<p>■ Non-stop defrost</p> <p>The diagram illustrates the sequence of events during a non-stop defrost cycle. It shows four horizontal timelines for different components: Indoor fan, CM (Compressor Motor), Solenoid valve (for hot gas bypass), and Outdoor fan. Vertical dashed lines mark the 'Defrost start' and 'Release' points. <ul style="list-style-type: none"> Indoor fan: Starts in 'Setting' mode. At 'Defrost start', it enters a 'Stop' state for 30 seconds, then returns to 'Setting'. CM (Compressor Motor): Turns 'ON' at 'Defrost start' and runs at 80 Hz until 'Release'. Solenoid valve (for hot gas bypass): Turns 'ON' for 5 seconds after 'Defrost start' and returns to 'OFF' 10 seconds before 'Release'. Outdoor fan: Turns 'ON' at 'Defrost start', goes 'OFF' during the defrost period, and turns 'ON' again at 'Release'. </p> <ul style="list-style-type: none"> The maximum length of defrost operation is 12 minutes. Defrost can also be released based on the below conditions for the outdoor heat exchanger sensor. <ul style="list-style-type: none"> Less than 2 minutes → Not released 2 minutes or more → 14 °C or higher (*1) <p>*1 However, the condition is (20 °C) or higher when the outdoor air temperature is below 0 °C.</p>

8-4. Trouble Diagnosis of Each Part

8-4-1. Problems of Each Part and Inspection Points

- For details about the inspection points, refer to the Inspection Points for Each Part.

Problems		Indoor unit				Outdoor unit								Others		No. of Inspection Points for Each part	
		Indoor unit does not operate.	Operation lamp blinking.	Operation lamp does not illuminate.	Indoor fan dose not turn.	Outdoor unit does not operate.	Outdoor fan dose not turn.	4-way valve does not operate.	The compressor (only) does not operate.	The compressor stops on occasion.	The compressor speed does not increase.	The outdoor air temperature is high, however defrost operation occurs.	Defrost operation does not occur.	The electric expansion valve does not operate.	Does not cool or cooling performance is inadequate.		Does not heat or heating performance is inadequate.
Self-Diagnostics check			<input type="radio"/>		<input type="radio"/>	<input type="radio"/>	<input type="radio"/>		<input type="radio"/>								
Indoor unit	Indoor controller (control unit)	<input type="radio"/>	<input type="radio"/>	<input type="radio"/>	<input type="radio"/>	<input type="radio"/>											
	Indoor fan motor		<input type="radio"/>		<input type="radio"/>												
	Room temperature sensor		<input type="radio"/>														
	Heat exchanger temperature sensor		<input type="radio"/>		<input type="radio"/>												
	Inter-unit cable		<input type="radio"/>			<input type="radio"/>	<input type="radio"/>	<input type="radio"/>	<input type="radio"/>	<input type="radio"/>	<input type="radio"/>						
	Switch circuit board	<input type="radio"/>		<input type="radio"/>													
Outdoor unit	Outdoor control circuit board		<input type="radio"/>			<input type="radio"/>	<input type="radio"/>	<input type="radio"/>	<input type="radio"/>	<input type="radio"/>	<input type="radio"/>						(1)
	Diode module		<input type="radio"/>			<input type="radio"/>											
	HIC		<input type="radio"/>			<input type="radio"/>											
	Electrolytic capacitor		<input type="radio"/>			<input type="radio"/>											
	Fuse		<input type="radio"/>			<input type="radio"/>											(2)
	Compressor		<input type="radio"/>			<input type="radio"/>	<input type="radio"/>	<input type="radio"/>	<input type="radio"/>	<input type="radio"/>	<input type="radio"/>						(3)
	Compressor protective sensor		<input type="radio"/>			<input type="radio"/>		<input type="radio"/>	<input type="radio"/>								(4)
	Outdoor fan motor		<input type="radio"/>			<input type="radio"/>	<input type="radio"/>		<input type="radio"/>		<input type="radio"/>						
	4-way valve						<input type="radio"/>										(5)
	Coil thermistor		<input type="radio"/>			<input type="radio"/>					<input type="radio"/>	<input type="radio"/>					(6)
Others	Breaker	<input type="radio"/>			<input type="radio"/>												(9)
	Refrigerant gas pressure							<input type="radio"/>						<input type="radio"/>	<input type="radio"/>		(10)

8-4-2. Inspection Points for Each Part

(1) Outdoor control circuit board

Refer to 8-3-1. Checking the outdoor unit.

NOTE Do not remove or insert the outdoor control circuit board connector when power is being supplied to it. (The controller will be damaged.)

(2) Fuse

Check it visually or the continuity with a tester.

(3) Compressor

Check for an open circuit in the compressor coil winding.

(4) Compressor protective sensor (compressor discharge temperature thermistor)

Check that the sensor is securely contained in the thermostart holder.

(5) 4-way valve

Short-circuit the T-RUN terminal to the COM terminal of TEST/T-RUN terminals. Perform a test run of the unit alone, and check whether the 4-way valve inside the outdoor unit produces a click sound.

(6) Coil thermistor

Check that the sensor is securely contained in the thermostat holder.

(7) Electric expansion valve

● When replacing the electric expansion valve and coil, be sure to attach the connectors in the correct positions. Labels are applied to the valve body and coil, corresponding to the connector colors, to identify them.

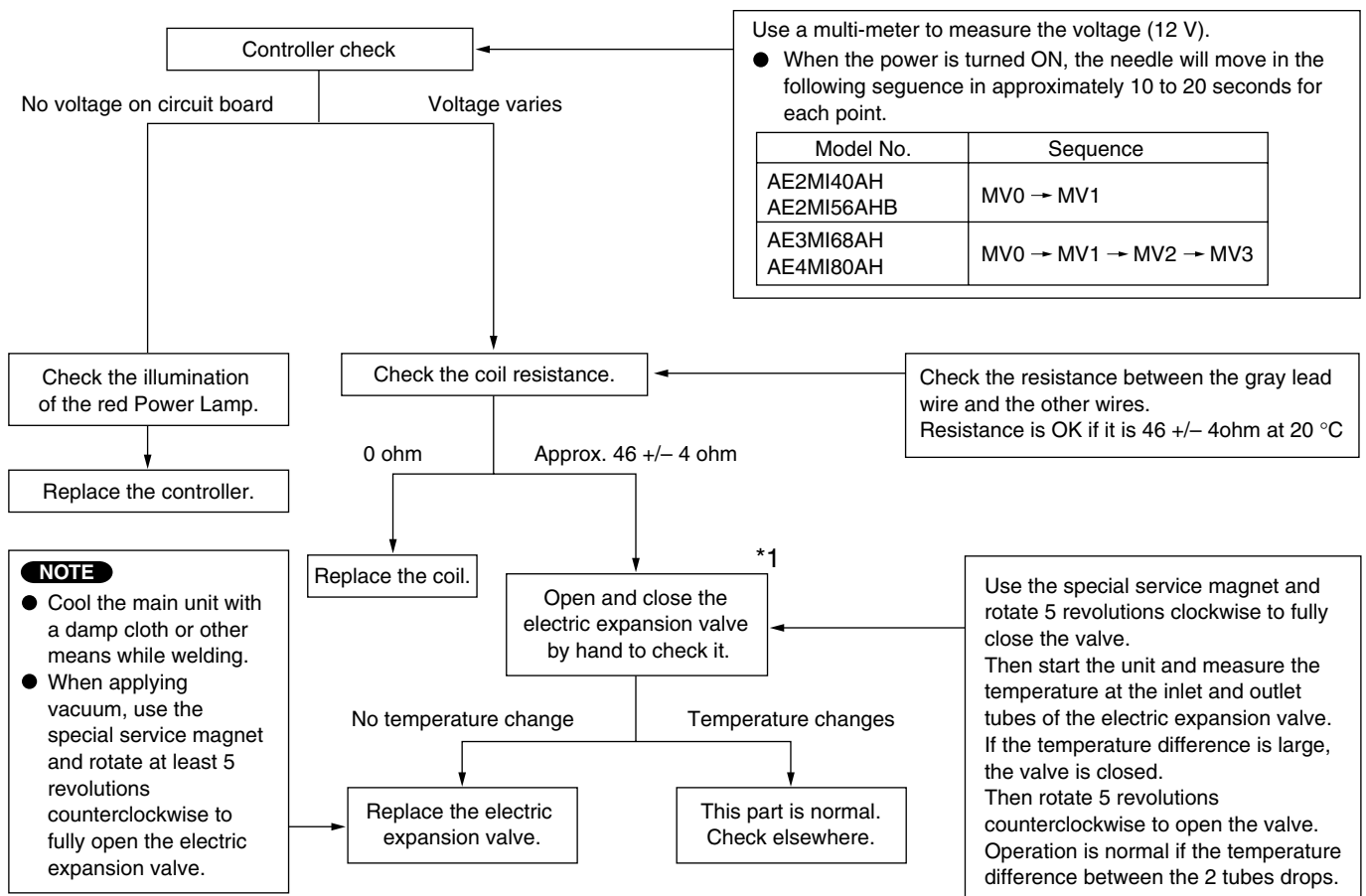

*1 If you have manually checked the electric expansion valve, be sure to reapply the outdoor power after you have replaced the wiring. (The position of the electric expansion valve will be changed.)

(8) Branch tubing temperature sensor

Check that the sensor is securely contained in the thermostat holder.

(9) Breaker

Check whether or not the breaker has been tripped.

- Check that the breakers and fuses used are of the specified capacity.
- Check that the breaker and its line are exclusive for A/C use.

(10) Refrigerant gas pressure

Start a COOL test run, and measure the temperatures of the A/C intake air and discharge air. Compare the values with the performance charts.

- If the values are higher than the performance charts:

Check for refrigerant shortage or blockage of the refrigerant circuit.

< Assessment of refrigerant shortage >

1. The pressure in the low-pressure section is 5 MPa or more below the value in the performance charts.
2. There is little condensation on the indoor heat exchanger, which overall appears dry.

< Distinguishing between refrigerant shortage and refrigerant circuit blockage >

If the pressure in the low-pressure section does not change when the circuit is charged 2 to 3 times with refrigerant gas (0.44 lbs each time), or if the change is small, then the problem may not be refrigerant shortage.

The problem may be a blockage of the refrigerant circuit.

1. Check that there is no internal leakage inside the 4-way valve:

At the low-pressure side tubing, check that there is no temperature difference between the intake and discharge of the 4-way valve.

2. Check that the electric expansion valve is not blocked. Check as described on the preceding page.

8-5. Trouble Diagnosis of Fan Motor

- This outdoor DC fan motor contains an internal control PCB. Therefore, it is not possible to measure the coil resistance, and the following procedure should be used to check the motor.
- Perform the trouble diagnosis by Test Run mode described on Installation Instructions of indoor unit.

Important: (A) Turn OFF the power before connecting or disconnecting the motor connectors.
 (B) When performing voltage measurement at the outdoor controller connector for (3) in the table below, the DC motor will trip and voltage output will stop approximately 10 seconds after operation is started. For this reason, to measure the voltage again, first turn OFF the outdoor unit power, then, measure the voltage in Test Run mode.

[Trouble symptom 1] The fan does not stop when the outdoor unit stops. →Outdoor unit controller trouble

[Trouble symptom 2] The fan motor does not rotate when the outdoor unit is operating.

(Diagnostic procedure)

- * Disconnect the motor connectors and measure the voltage at the DC motor connectors on the outdoor unit controller (3 locations).

Measurement location	Normal value
(1) Vs-Gnd : Between pin 1 and pin 4 or Vm-Gnd : Between pin 1 and pin 4	DC 230V or more
(2) Vcc-Gnd : Between pin 5 and pin 4	DC 14V or more
(3) Vsp-Gnd : Between pin 7 and pin 4	After fluctuating 4 times between DC 1.7 to 6.1V (1 sec. ON) and DC 0 V (1 sec. OFF), the DC motor trips.

(Diagnostic results)

All of the above measured values are normal. → Fan motor trouble (Replace the motor.)

Any one of the above measured values is not normal. →Outdoor unit controller trouble
 (Replace the controller .)

(Reference)

DC motor connector pin arrangement

AE2MI40AH	AE2MI56AHB AE3MI68AH / AE4MI80AH
Pin 1: Vs (white)	Pin 1: Vm (red)
Pin 2: Not used	Pin 2: Not used
Pin 3: Not used	Pin 3: Not used
Pin 4: Gnd (black)	Pin 4: Gnd (blue)
Pin 5: Vcc (red)	Pin 5: Vcc (brown)
Pin 6: FG (blue)	Pin 6: PG (white)
Pin 7: Vsp (yellow)	Pin 7: Vsp (orange)

[Trouble symptom 3] Motor rotates for some time (several seconds), but then quickly stops, when the outdoor unit operates.

(There is trouble in the system that provides feedback of motor rotation speed from the motor to the outdoor unit controller.)

[Trouble symptom 4] Fan motor rotation speed does not change during outdoor unit operation.

[Trouble symptom 5] Fan motor rotation speed varies excessively during outdoor unit operation.

(Remedy for symptom 3 to 5)

It is not possible to identify whether the trouble is outdoor unit controller trouble or motor trouble. Therefore, first replace the outdoor unit controller, then (if necessary) replace the DC motor.

9. REFRIGERANT R410A: SPECIAL PRECAUTIONS WHEN SERVICING UNIT

9-1. Characteristics of New Refrigerant R410A

9-1-1. What is New Refrigerant R410A?

R410A is a new refrigerant that contains two types of pseudo-non-azeotropic refrigerant mixture. Its refrigeration capacity and energy efficiency are about the same level as the conventional refrigerant, R22.

9-1-2. Components (mixing proportions)

HFC32 (50%) / HFC125 (50%)

9-1-3. Characteristics

- Less toxic, more chemically stable refrigerant
- The composition of refrigerant R410A changes whether it is in a gaseous phase or liquid phase. Thus, when there is a refrigerant leak the basic performance of the air conditioner may be degraded because of a change in composition of the remaining refrigerant. **Therefore, do not add new refrigerant.** Instead, recover the remaining refrigerant with the refrigerant recovery unit. Then, after evacuation, totally recharge the specified amount of refrigerant with the new refrigerant at its normal mixed composition state (in liquid phase).
- When refrigerant R410A is used, the composition will differ depending on whether it is in gaseous or liquid phase, and the basic performance of the air conditioner will be degraded if it is charged while the refrigerant is in gaseous state. **Thus, always charge the refrigerant while it is in liquid phase.**



CAUTION

Ether-type oil is used for compressor oil for R410A-type units, which is different from the mineral oil used for R22. Thus more attention to moisture prevention and faster replacement work compared with conventional models are required.

9-2. Checklist before Servicing

Use a clutch-type flare tool for R410A or the conventional flare tool. Note that sizes of the resultant flares differ between these two tools. Where a conventional flare tool is used, make sure to observe A Specification (amount of extrusion) by using the flare spacer.

Diameter of tube D	Specification A	
	Flare tool for R410A	Conventional flare tool (for R22)
Dia.6.35 mm (1/4")	0 to 0.5 mm	1.2 mm
Dia.9.52 mm (3/8")		
Dia.12.7 mm (1/2")		
Dia.15.88 mm (5/8")		

● Size of flare

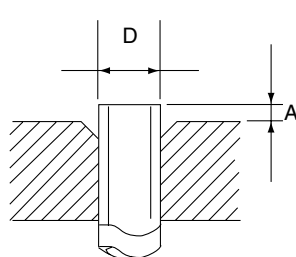

Flare tool for R410A

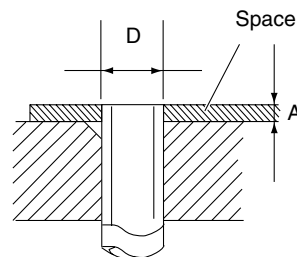

Conventional flare tool (R22)

- **Tubing precautions**

- Refrigerant R410A is more easily affected by dust or moisture compared with R22, thus be sure to temporarily cover the ends of the tubing with caps or tape prior to installation.

Never use 0.7mm-thick copper tubing or tubing which is less than 0.8mm in thickness, since air conditioners with R410A are subject to higher pressure than those using R22 and R407C.

- **No addition of compressor oil for R410A**

No additional charge of compressor oil is permitted.

- **No use of refrigerant other than R410A**

Never use a refrigerant other than R410A.

- **If refrigerant R410A is exposed to fire**

Through welding, etc., toxic gas may be released when R410A refrigerant is exposed to fire. Therefore, be sure to provide ample ventilation during installation work.

- **Caution in case of R410A leak**

Check for possible leak points with the special leak detector for R410A. If a leak occurs inside the room, immediately provide thorough ventilation.

9-3. Tools Specifically for R410A

- For servicing, use the following tools for R410A

Tool Distinction	Tool Name
Tools specifically for R410A	<ul style="list-style-type: none"> ● Gauge manifold ● Charging hose ● Gas leak detector ● Refrigerant cylinder ● Charging cylinder ● Refrigerant recovery unit ● Vacuum pump with anti-reverse flow (*1) (Solenoid valve-installed type, which prevents oil from flowing back into the unit when the power is off, is recommended.) ● Vacuum pump (*2)...can be used if the following adapter is attached. ● Vacuum pump adapter (reverse-flow prevention adapter) (*3). (Solenoid valve-installed adapter attached to a conventional vacuum pump.) ● Electronic scale for charging refrigerant ● Flare tool
Tools which can be commonly used for R22, R407C, and R410A	<ul style="list-style-type: none"> ● Bender ● Torque wrench ● Cutter, reamer ● Welding tool, nitrogen gas cylinder



CAUTION

- The above tools specifically for R410A must not be used for R22 and R407C. Doing so will cause malfunction of the unit.
- For the above vacuum pump (*1, *2) and vacuum pump adapter (*3), those for R22-type units can be used for R410A-type. However, they must be used exclusively for R410A and never alternately with R22 and R407C.
- To prevent other refrigerants (R22, R407C) from being mistakenly charged to this unit, shape and external diameter of the service port screw has been altered.
 <External diameter of service port> R410A : 7.94 mm (5/16")
 R22, R407C : 6.35 mm (1/4")

9-4. Tubing Installation Procedures

When the tubes are connected, **always apply HAB oil on the flare portions to improve the sealing of tubing.**

The following is the **HAB oil** generally used:

Esso: ZERICE S32

NOTE

For details on tubing installation procedures, refer to the installation manuals attached to the indoor unit and outdoor unit.

9-5. In Case of Compressor Malfunction



CAUTION

- Should the compressor malfunction, be sure to make the switch to a replacement compressor as quickly as possible.
- Use only the tools indicated exclusively for R410A. → See "9-3. Tools Specifically for R410A."

9-5-1. Procedure for Replacing Compressor

(1) Recovering refrigerant

- Any remaining refrigerant inside the unit should not be released to the atmosphere, but recovered using the refrigerant recovery unit for R410A.
- Do not reuse the recovered refrigerant, since it will contain impurities.

(2) Replacing Compressor

- Soon after removing seals of both discharge and suction tubes of the new compressor, replace it quickly.

(3) Checking for sealing

- Use nitrogen gas for the pressurized gas, and never use a refrigerant other than R410A. Also do not use oxygen or any flammable gas.

(4) Evacuation

- **Use a solenoid valve-installed vacuum pump** so that even if power is cut off in the middle of evacuation of air due to a power interruption, the valve will prevent the pump oil from flowing back.
- The equipment may be damaged if moisture remains in the tubing, thus carry out the evacuation thoroughly.
- When using a vacuum pump with exhaust air volume more than 25L/min. and ultimate vacuum pressure rate of 0.05Torr.

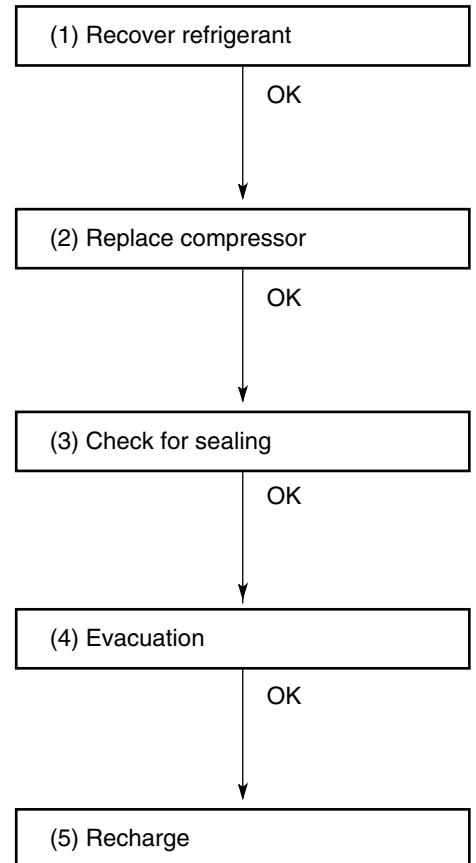

Standard time for evacuation

Length of tubing	Less than 10 meters	More than 10 meters
Evacuation time	More than 10 minutes	More than 15 minutes

(5) Recharging

- **Be sure to charge the specified amount of refrigerant in liquid state** using the service port of the wide tube service valve. The proper amount is listed on the unit's nameplate.

When the entire amount cannot be charged all at once, charge gradually while operating the unit in Cooling Operation.



CAUTION

Never charge a large amount of liquid refrigerant at once to the unit. This may cause damage to the compressor.

- When charging with a refrigerant cylinder, use an electronic scale for charging refrigerant. In this case, if the volume of refrigerant in the cylinder becomes less than 20% of the fully-charged amount, the composition of the refrigerant starts to change. Thus, **do not use the refrigerant if the amount in the charging cylinder is less than 20%.**

Also, charge the minimum necessary amount to the charging cylinder before using it to charge the air conditioning unit.

Example:

In case of charging refrigerant to a unit requiring 0.76Kg using a capacity of a 10Kg cylinder, the minimum necessary amount for the cylinder is:

$$0.76 + 10 \times 0.20 = 2.76\text{Kg}$$

For the remaining refrigerant, refer to the instructions of the refrigerant manufacturer.

- If using a charging cylinder, transfer the specified amount of liquid refrigerant from the refrigerant cylinder to the charging cylinder.

Prepare an evacuated charging cylinder beforehand.



CAUTION

- **To prevent the composition of R410A from changing, never bleed the refrigerant gas into the atmosphere while transferring the refrigerant. (Fig. 3)**

Do not use the refrigerant if the amount in the charging cylinder is less than 20%.

Configuration and characteristics of cylinders

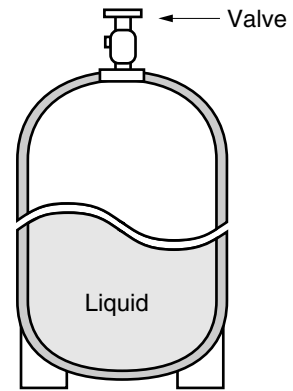

Single valve
Charge liquid refrigerant with cylinder in up-side-down position.

Fig. 1

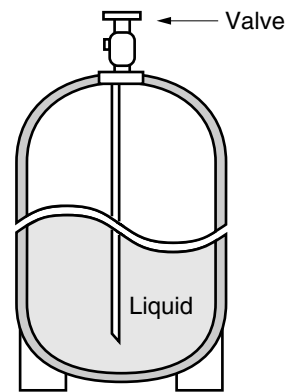

Single valve (with siphon tube)
Charge with cylinder in normal position.

Fig. 2

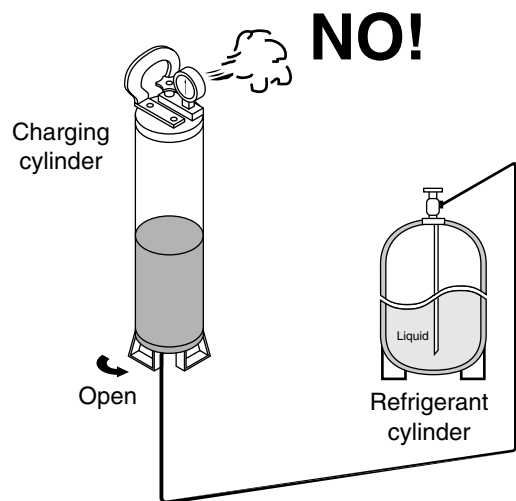

Fig. 3

9-6. In Case Refrigerant is Leaking



CAUTION

Never attempt to charge additional refrigerant when refrigerant has been leaking from the unit. Follow the procedure described below to locate points of leaks and carry out repairs, then recharge the refrigerant.

(1) Detecting Leaks

- Use the detector for R410A to locate refrigerant leak points.

(2) Recovering refrigerant

- Never release the gas to the atmosphere; recover residual refrigerant using the refrigerant recovery unit for R410A, instead.
- Do not reuse the recovered refrigerant because its composition will have been altered.

(3) Welding leaking points

- Confirm again that no residual refrigerant exists in the unit before starting welding.
- Weld securely using flux and wax for R410A.
- Prevent oxide film from forming inside the tubes utilizing substitution with nitrogen (N₂) in the refrigerant circuit of the unit. Leave ends of tubes open during welding.

(4) Checking for sealing

- Use nitrogen gas for the pressurized gas, and never use a refrigerant other than R410A. Also do not use oxygen or any flammable gas.

(5) Evacuation

- **Use a solenoid valve-installed vacuum pump** so that even if power is cut off in the middle of evacuation of air due to a power interruption, the valve will prevent the pump oil from flowing back.
- The equipment may be damaged if moisture remains in the tubing, thus carry out the evacuation thoroughly.
- When using a vacuum pump with exhaust air volume more than 25L/min. and ultimate vacuum pressure rate of 0.05Torr.

Standard time for evacuation

Length of tubing	Less than 10 meters	More than 10 meters
Evacuation time	More than 10 minutes	More than 15 minutes

(6) Recharging

- Recharge unit in the same manner explained on the previous page "(5) Recharging."

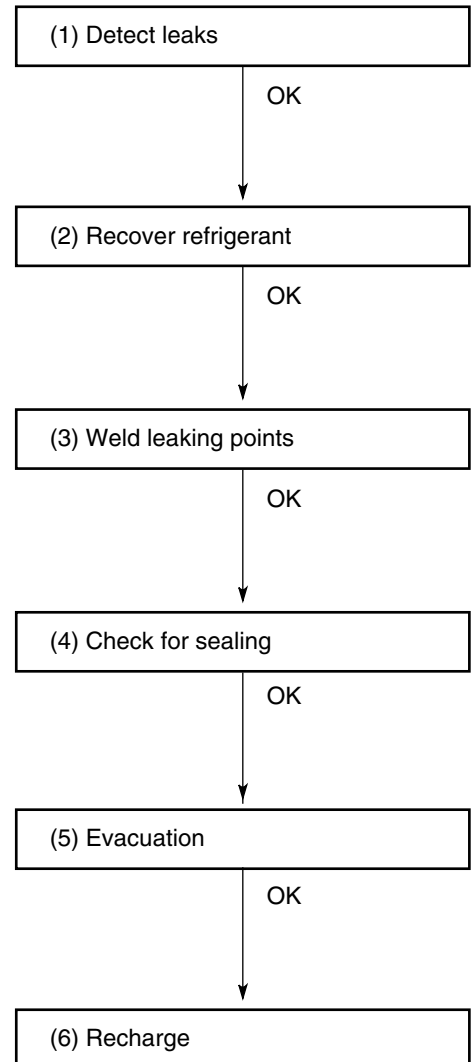

9-7. Charging Additional Refrigerant

9-7-1. When Tubes are Extended

- Observe the proper amount of refrigerant as stated in this service manual or the installation manual that came with the indoor unit. **Charge additional refrigerant in liquid state only.**



CAUTION

Never charge additional refrigerant if refrigerant is leaking from the unit. Follow instructions given in "9-6. In Case Refrigerant is Leaking" and completely carry out repairs. Only then should you recharge the refrigerant.

9-8. Retro-Fitting Existing Systems

9-8-1. Use of Existing Units

- **Never use new refrigerant R410A for existing units which use R22.** This will cause the air conditioner to operate improperly and may result in a hazardous condition.

9-8-2. Use of Existing Tubing

- If replacing an older unit that used refrigerant R22 with a R410A unit, **do not use its existing tubing.** Instead, completely new tubing must be used.

APPENDIX A INSTALLATION INSTRUCTIONS

AE2MI40AH
AE2MI56AHB
AE3MI68AH
AE4MI80AH

(II-852-6-4190-444-00-0)



For Outdoor Unit

INSTALLATION INSTRUCTIONS

– Multi Split system air conditioner –

COOL/DRY/HEAT Model

This air conditioner uses the new refrigerant R410A.

Contents

IMPORTANT!

Please Read Before Starting 2

1. GENERAL 3

- 1-1. Tools Required for Installation (not supplied)
- 1-2. Accessories Supplied with Unit
- 1-3. Optional Copper Tubing Kit
- 1-4. Type of Copper Tube and Insulation Material
- 1-5. Additional Materials Required for Installation

2. INSTALLATION SITE SELECTION 4

- 2-1. Indoor Unit
- 2-2. Connecting Indoor Units
- 2-3. Outdoor Unit
- 2-4. Outer Dimensions of Outdoor Unit
- 2-5. Diagram of Outdoor Unit Installation

3. INSTALLATION PROCESS 13

- 3-1. Embedding the Tubing and Wiring
- 3-2. Drain Cap and Drain Elbow
- 3-3. Use of the Flaring Method
- 3-4. Flaring Procedure with a Flare Tool
- 3-5. Caution Before Connecting Tubes Tightly
- 3-6. Tubing Connections
- 3-7. Insulation of Refrigerant Tubing
- 3-8. Taping the Tubes
- 3-9. Finishing the Installation

4. AIR PURGING 16

- Air Purging with a Vacuum Pump (for Test Run)
- Pump Down

5. WIRING INSTRUCTIONS 19

- 5-1. General Precautions on Wiring
- 5-2. Recommended Wire Length and Diameter
- 5-3. Wiring System Diagram
- 5-4. How to Connect Wiring to the Terminal
- 5-5. Wiring Instructions for the Outdoor Unit

6. TEST RUN 23

7. CONNECTING A HOME AUTOMATION DEVICE 24

8. INSTALLATION CHECK SHEET 24

9. ELECTRIC WIRING DIAGRAM 25

Page

Model Combinations

Combine indoor and outdoor units only as listed below.

Indoor Unit	Outdoor Unit
AWMI22AHL	AE2MI40AH
AWMI27AHL	AE2MI56AHB
AWMI35AHL	AE3MI68AH
AWI52AHL	AE4MI80AH
AWI68AHL	

Combine indoor and outdoor units only as listed in the combination tables for 2-room, 3-room or 4-room outdoor unit as shown in its respective manual.

Power Source:
50 Hz, single-phase, 220 – 240 VAC

Be sure to read the yellow instruction sheet attached to the outdoor unit for models using the new refrigerant R410A.

Combination example

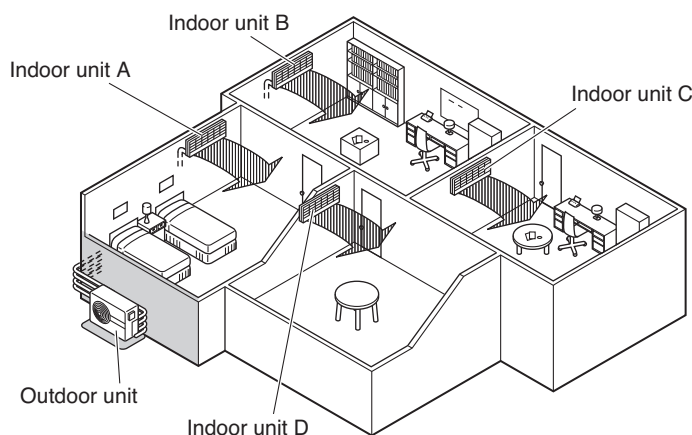

NOTE

The illustrations are based on the typical appearance of a standard model. Consequently, the shape may differ from that of the air conditioner that you are installing.

IMPORTANT! Please Read Before Starting

This air conditioning system meets strict safety and operating standards. As the installer or service person, it is an important part of your job to install or service the system so it operates safely and efficiently.

For safe installation and trouble-free operation, you must:

- Carefully read this instruction booklet before beginning.
- Follow each installation or repair step exactly as shown.
- Observe all local, state, and national electrical codes.
- Pay close attention to all warning and caution notices given in this manual.



WARNING

This symbol refers to a hazard or unsafe practice which can result in severe personal injury or death.



CAUTION

This symbol refers to a hazard or unsafe practice which can result in personal injury or product or property damage.

If Necessary, Get Help

These instructions are all you need for most installation sites and maintenance conditions. If you require help for a special problem, contact our sales/service outlet or your certified dealer for additional instructions.

In Case of Improper Installation

The manufacturer shall in no way be responsible for improper installation or maintenance service, including failure to follow the instructions in this document.

SPECIAL PRECAUTIONS

WARNING

When Wiring



ELECTRICAL SHOCK CAN CAUSE SEVERE PERSONAL INJURY OR DEATH. ONLY A QUALIFIED, EXPERIENCED ELECTRICIAN SHOULD ATTEMPT TO WIRE THIS SYSTEM.

- Do not supply power to the unit until all wiring and tubing are completed or reconnected and checked.
- Highly dangerous electrical voltages are used in this system. Carefully refer to the wiring diagram and these instructions when wiring. Improper connections and inadequate grounding can cause **accidental injury or death**.
- **Ground the unit** following local electrical codes.
- Connect all wiring tightly. Loose wiring may cause overheating at connection points and a possible fire hazard.
- Install a protective **leakage breaker** depending on the installation location (especially a damp or humid location). If a **leakage breaker** is not installed, electric shock can occur.

When Transporting

Be careful when picking up and moving the indoor and outdoor units. Get a partner to help, and bend your knees when lifting to reduce strain on your back. Sharp edges or thin aluminum fins on the air conditioner can cut your fingers.

When Installing ...

...In a Ceiling or Wall

Make sure the ceiling/wall is strong enough to hold the unit's weight. It may be necessary to construct a strong wood or metal frame to provide added support.

...In a Room

Properly insulate any tubing run inside a room to prevent "sweating" that can cause dripping and water damage to walls and floors.

...In Moist or Uneven Locations

Use a raised concrete pad or concrete blocks to provide a solid, level foundation for the outdoor unit. This prevents water damage and abnormal vibration.

...In an Area with High Winds

Securely anchor the outdoor unit down with bolts and a metal frame. Provide a suitable air baffle.

...In a Snowy Area (for Heat Pump-type Systems)

- Position the outdoor unit in a protected location where snow will not blow into it.
- Install the outdoor unit on a raised platform that is higher than drifting snow. Provide snow vents.

When Connecting Refrigerant Tubing

- Use the flare method for connecting tubing.
- Apply refrigerant lubricant to the matching surfaces of the flare and union tubes before connecting them, then tighten the nut with a torque wrench for a leak-free connection.
- Check carefully for leaks before starting the test run.

When Servicing

- Turn the power OFF at the main power box (mains) before opening the unit to check or repair electrical parts and wiring.
- Keep your fingers and clothing away from any moving parts.
- Clean up the site after you finish, remembering to check that no metal scraps or bits of wiring have been left inside the unit being serviced.



CAUTION

Others

- Ventilate any enclosed areas when installing or testing the refrigeration system. Escaped refrigerant gas, on contact with fire or heat, can produce dangerously toxic gas.
- Confirm upon completing installation that no refrigerant gas is leaking. If escaped gas comes in contact with a stove, gas water heater, electric room heater or other heat source, it can produce dangerously toxic gas.
- Do not install only a single indoor unit.

1. General







This booklet briefly outlines where and how to install the air conditioning system. Please read over the entire set of instructions for the indoor and outdoor units and make sure all accessory parts listed are with the system before beginning. If the electric wiring diagram does not appear in this manual, please check for the diagram on the indoor unit.

1-1. Tools Required for Installation (not supplied)

1. Standard screwdriver
2. Phillips head screwdriver
3. Knife or wire stripper
4. Tape measure
5. Carpenter's level
6. Sabre saw or key hole saw
7. Hacksaw
8. Core bits
9. Hammer
10. Drill
11. Tube cutter
12. Tube flaring tool
13. Torque wrench
14. Adjustable wrench
15. Reamer (for deburring)
16. Vacuum pump (For R410A)
17. Manifold valve

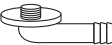
1-2. Accessories Supplied with Unit

Table 1

Parts	Figure	Q'ty	Parts	Figure	Q'ty		
Reducer ($\phi 9.52 \times \phi 12.70$)		AE2MI56	1	Reducer ($\phi 12.70 \times \phi 9.52$)		AE3MI68	1
						AE4MI80	2
Drain elbow		1	Labels for inter-unit cable and tube		4 each		
Cushion rubber		4	Drain cap		AE2MI56/AE3MI68/AE4MI80	5	
					AE2MI40	4	

Packed in the outdoor unit.

1-3. Optional Copper Tubing Kit

Copper tubing for connecting the outdoor unit to the indoor unit is available in kits which contain the narrow and wide tubing, fittings and insulation. Consult your nearest sales outlet or Air Conditioner workshop.

1-4. Type of Copper Tube and Insulation Material

If you wish to purchase these materials separately from a local source, you will need:

1. Deoxidized annealed copper tube for refrigerant tubing as detailed in Table 2.
Cut each tube to the appropriate lengths +30 cm to 40 cm to dampen vibration between units.

2. Foamed polyethylene insulation for the specified copper tubes as required to precise length of tubing. Wall thickness of the insulation should be not less than 8 mm.
3. Use insulated copper wire for field wiring. Wire size varies with the total length of wiring. Refer to 5. Wiring Instructions for details.



CAUTION

Check local electrical codes and regulations before obtaining wire. Also, check any specified instructions or limitations.

Table 2

Model	Narrow Tube		Wide Tube	
	Outer Dia.	Thickness	Outer Dia.	Thickness
AWMI22	6.35 mm	0.8 mm	9.52 mm	0.8 mm
AWMI27	6.35 mm	0.8 mm	9.52 mm	0.8 mm
AWMI35	6.35 mm	0.8 mm	9.52 mm	0.8 mm
AWI52	6.35 mm	0.8 mm	12.70 mm	0.8 mm
AWI68	6.35 mm	0.8 mm	15.88 mm	1.0 mm

1-5. Additional Materials Required for Installation

1. Refrigeration (armored) tape
2. Insulated staples or clamps for connecting wire
(See local codes)
3. Putty
4. Refrigeration lubricant
5. Clamps or saddles to secure refrigerant tubing

2. Installation Site Selection

2-1. Indoor Unit



WARNING

To prevent abnormal heat generation and the possibility of fire, do not place obstacles, enclosures and grilles in front of or surrounding the air conditioner in a way that may block air flow.

AVOID:

- direct sunlight.
- nearby heat sources that may affect performance of the unit.
- areas where leakage of flammable gas may be expected.
- placing or allowing any obstructions near the Air Conditioner inlet or outlet.
- installing in rooms that contain instant-on (rapid-start) fluorescent lamps. (These may prevent the Air Conditioner from receiving signals.)
- places where large amounts of oil mist exist.
- installing in locations where there are devices that generate high-frequency emissions.

DO:

- select an appropriate position from which every corner of the room can be uniformly cooled. (High on a wall is best.)
- select a location that will hold the weight of the unit.
- select a location where tubing and drain hose have the shortest run to the outside. (Fig. 1)
- allow room for operation and maintenance as well as unrestricted air flow around the unit. (Fig. 2)
- install the unit within the maximum elevation difference (H1, H2, H3, H4) above or below the outdoor unit and within a total tubing length (L1+L2, L1+L2+L3, L1+L2+L3+L4) from the outdoor unit as detailed in Table 3 and Fig. 3a.

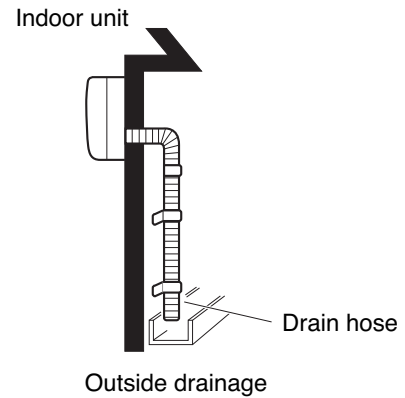
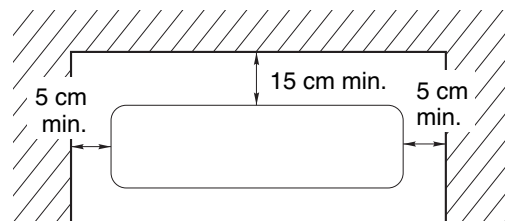

Fig. 1



Front View

Fig. 2

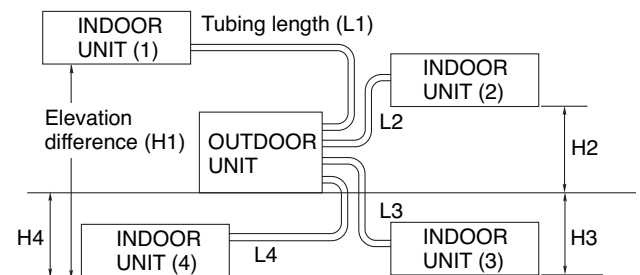

Fig. 3a



CAUTION

For stable operation of the air conditioner, do not install wall-mounted type indoor units less than 1.5 m from floor level.

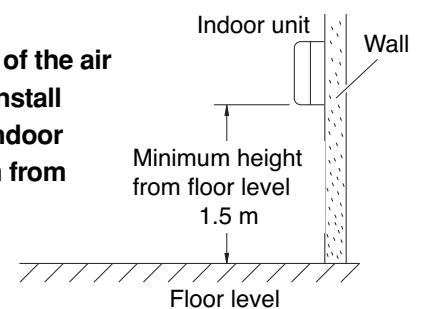

Fig. 3b

- Install the indoor unit more than 1 meter away from any antenna or power lines or connecting wires used for television, radio, telephone, security system, or intercom. Electrical noise from any of these sources may affect operation.
- install in a sturdy manner to avoid increased operating noise.

Table 3

Model	Max. Allowable Tubing Length per unit (m)	Max. Allowable Total Tubing Length at shipment (L1+L2) or (L1+L2+L3) or (L1+L2+L3+L4) (m)	Limit of Total Tubing Length (L1+L2) or (L1+L2+L3) or (L1+L2+L3+L4) (m)	Limit of Elevation Difference (H1, H2, H3, H4) (m)	Required Amount of Additional Refrigerant (g/m)*
AE2MI40	20	30 (L1+L2)	30 (L1+L2)	15	–
AE2MI56	25	45 (L1+L2)	45 (L1+L2)	15	–
AE3MI68	25	45 (L1+L2+L3+L4)	60 (L1+L2+L3+L4)	15	20
AE4MI80	30	45 (L1+L2+L3+L4)	70 (L1+L2+L3+L4)	15	20

* If total tubing length becomes 45 to 60 m (max.) or 45 to 70 m (max.), charge additional refrigerant (R410A) by 20 g/m. No additional charge of compressor oil is necessary.

2-2. Connecting Indoor Units

(1) Connecting indoor unit for AE2MI40AH

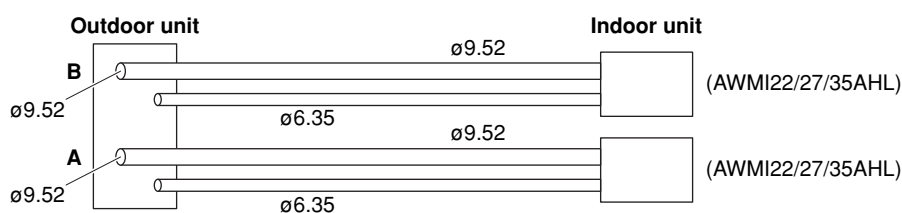

Fig. 4a

(2) Connecting indoor unit for AE2MI56AHB

(A)

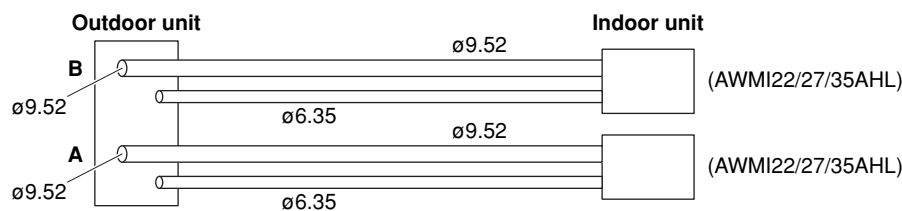
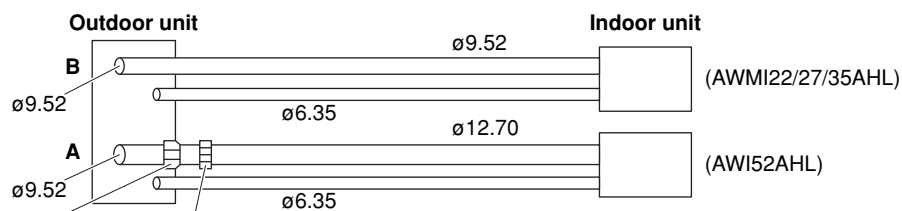

Fig. 4b

(B)



Flare ø9.52 Union ø12.70
A joint for connecting tubes of different sizes
(ø9.52 → ø12.70) Supplied Reducer

Fig. 4c

unit: mm

(3) Connecting indoor unit for AE3MI68AH

(A)

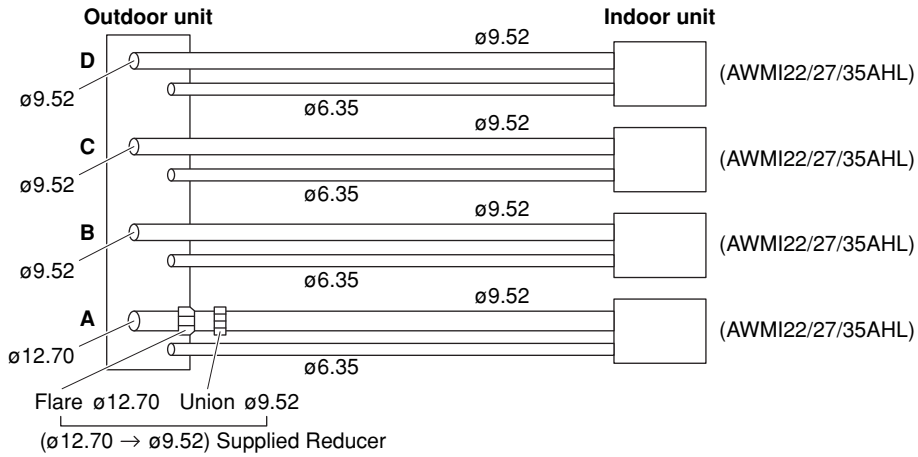

Fig. 4d

(B)

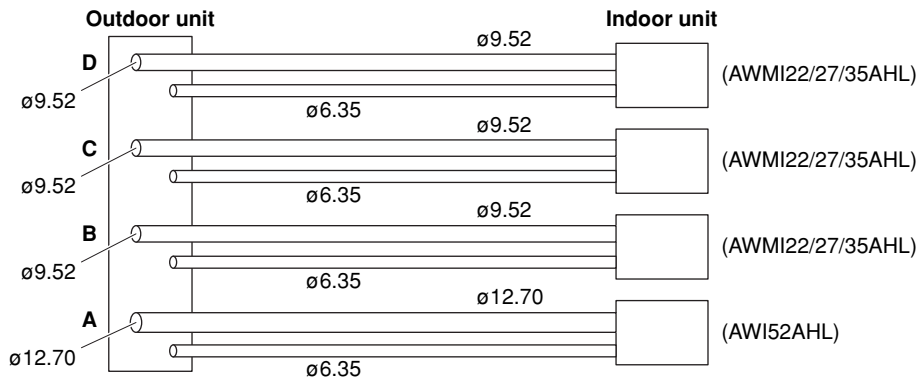

Fig. 4e

(C)

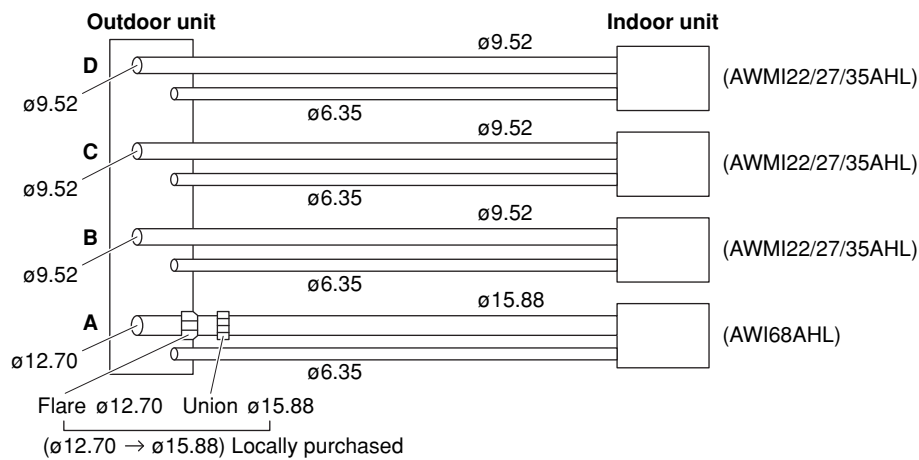

Fig. 4f

unit: mm

(D)

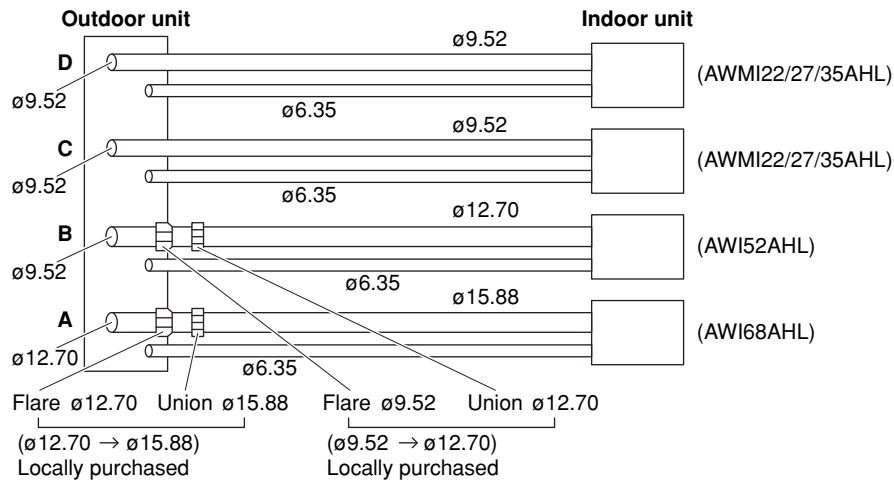

Fig. 4g

(4) Connecting indoor unit for AE4MI80AH

(A)

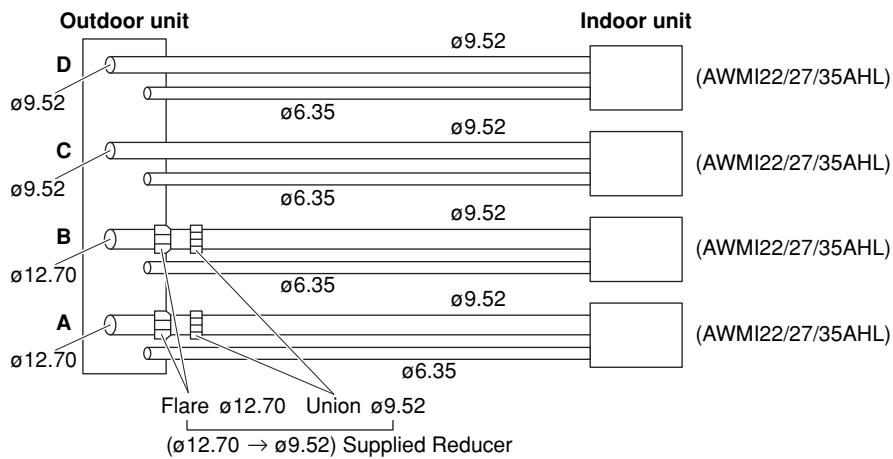

Fig. 4h

(B)

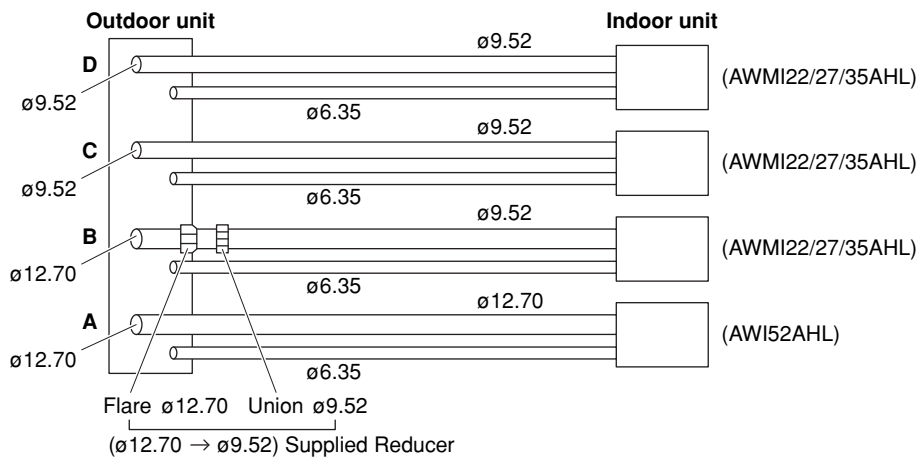

Fig. 4i

unit: mm

(C)

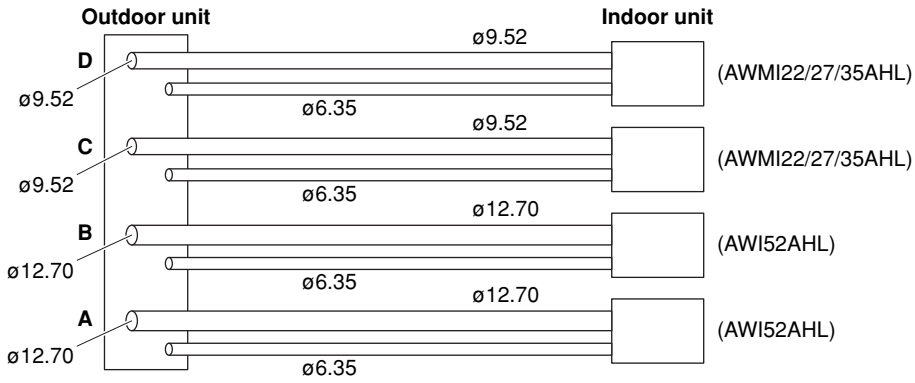

Fig. 4j

(D)

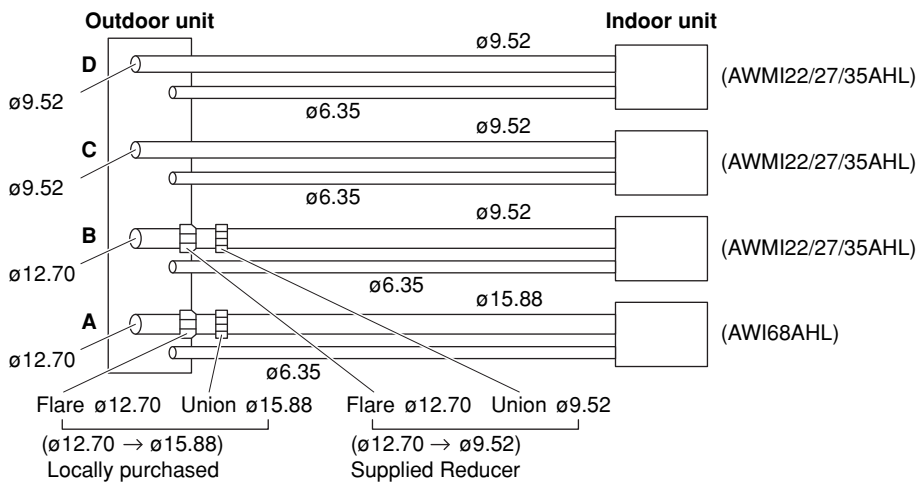

Fig. 4k

(E)

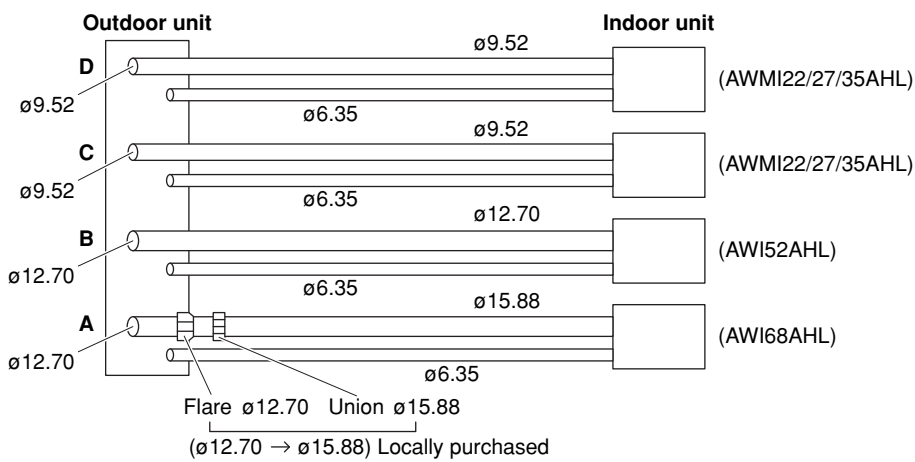

Fig. 4l

unit: mm

2-3. Outdoor Unit

AVOID:

- heat sources, exhaust fans, etc. (Fig. 5a)
- damp, humid or uneven locations.

DO:

- position the outdoor unit in a protected location where snow will not blow into it.
- choose a place as cool as possible.
- choose a place that is well ventilated.
- allow enough room around the unit for air intake/exhaust and possible maintenance. (Fig. 5b-1 or 5b-2)
- provide a solid base (level concrete pad, concrete block, 10 × 40 cm or 15 × 40 cm beams or equal), a minimum of 10 cm or 15 cm above ground level to reduce humidity and protect the unit against possible water damage and decreased service life. (Fig. 5c-1 or 5c-2)
- Install cushion rubber under unit's feet to reduce vibration and noise. (Fig. 5d)
- use lug bolts or equal to bolt down unit, reducing vibration and noise.
- Install in a location where no antenna of a television or radio exists within 3 meters.

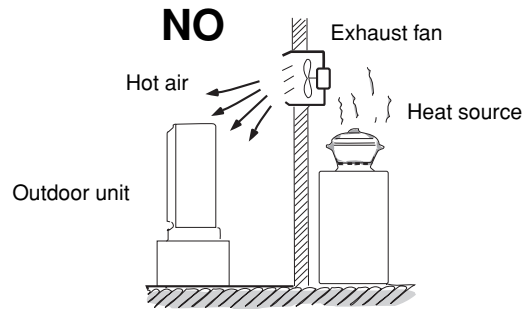

Fig. 5a

(AE2MI40)

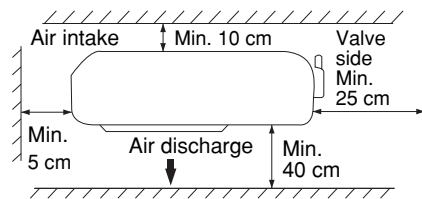
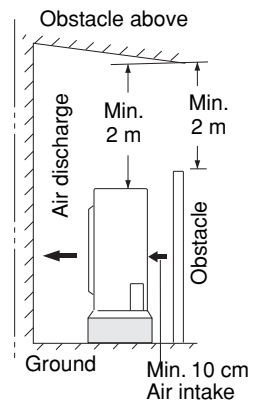

Fig. 5b-1



(AE2MI56, AE3MI68, AE4MI80)

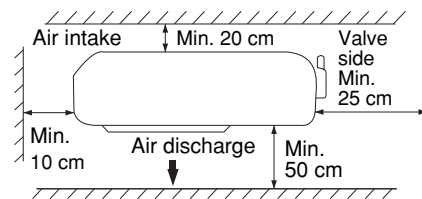
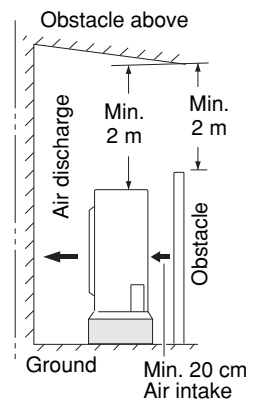

Fig. 5b-2



(AE2MI40)

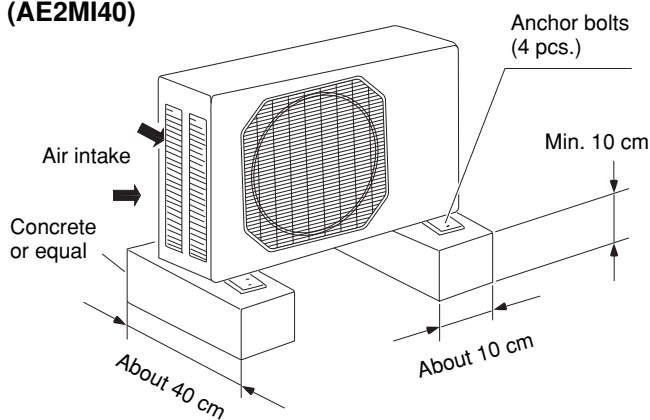

Fig. 5c-1

(AE2MI56, AE3MI68, AE4MI80)

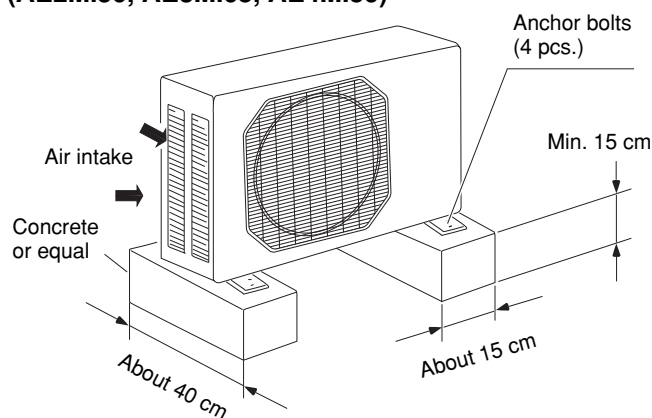

Fig. 5c-2

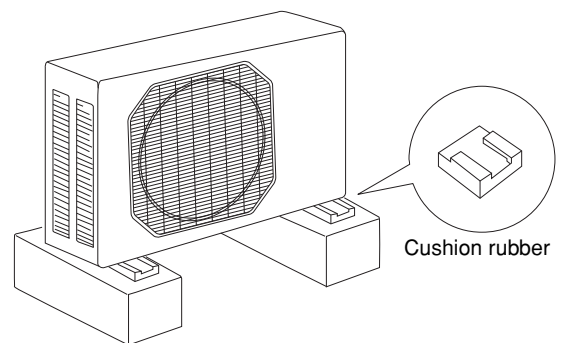

Fig. 5d

2-4. Outer Dimensions of Outdoor Unit

(1) AE2MI40AH

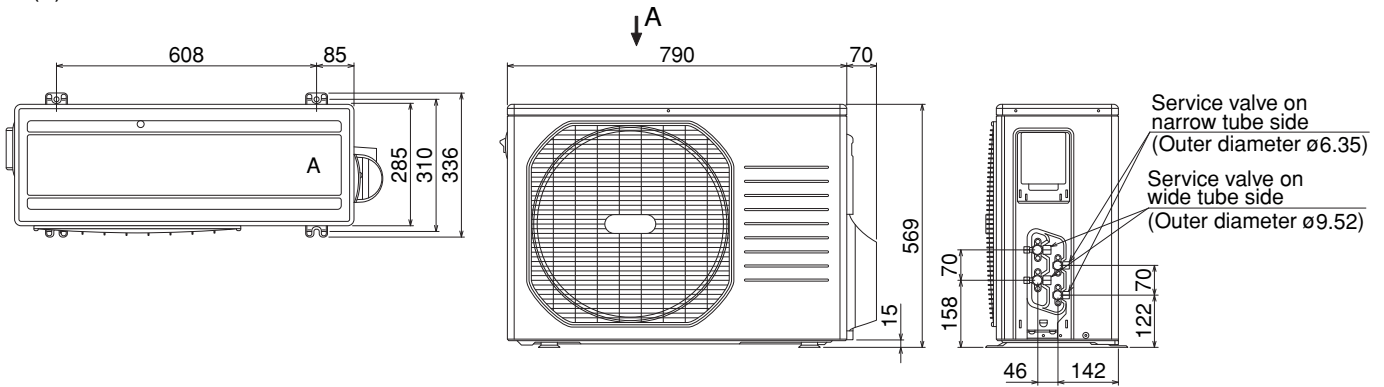

Fig. 6a

(2) AE2MI56AHB

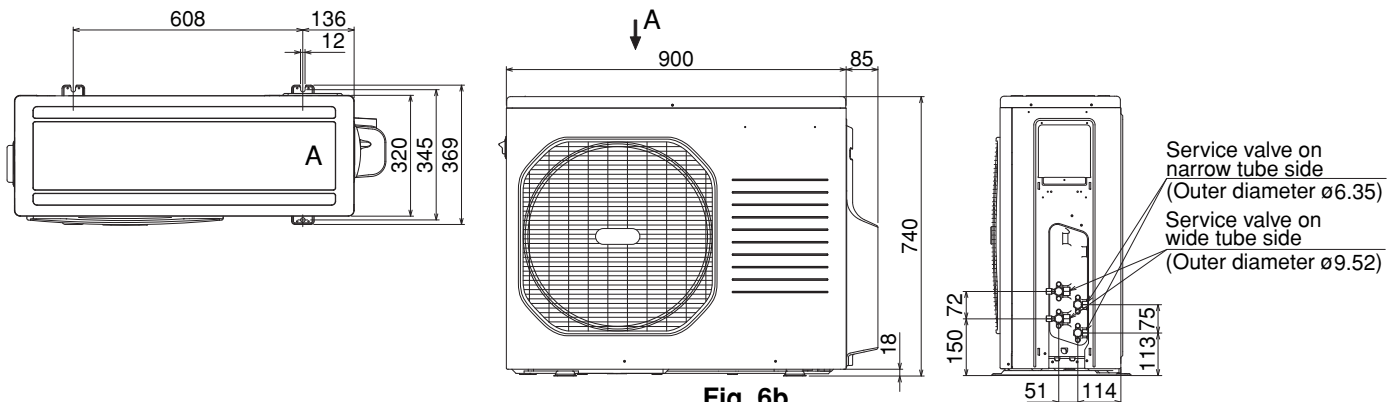

Fig. 6b

(3) AE3MI68AH

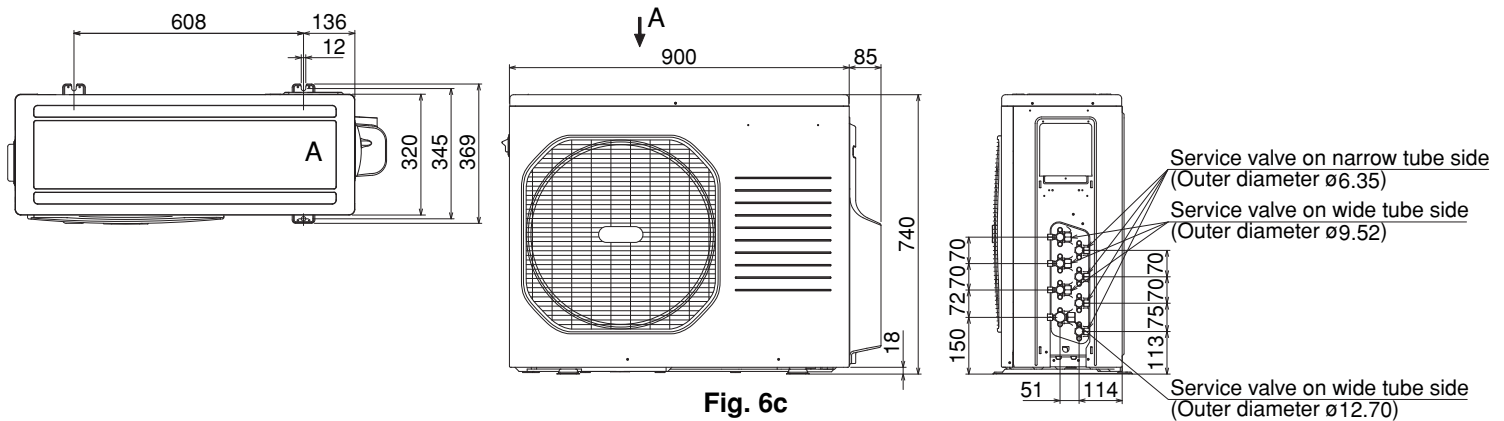

Fig. 6c

(4) AE4MI80AH

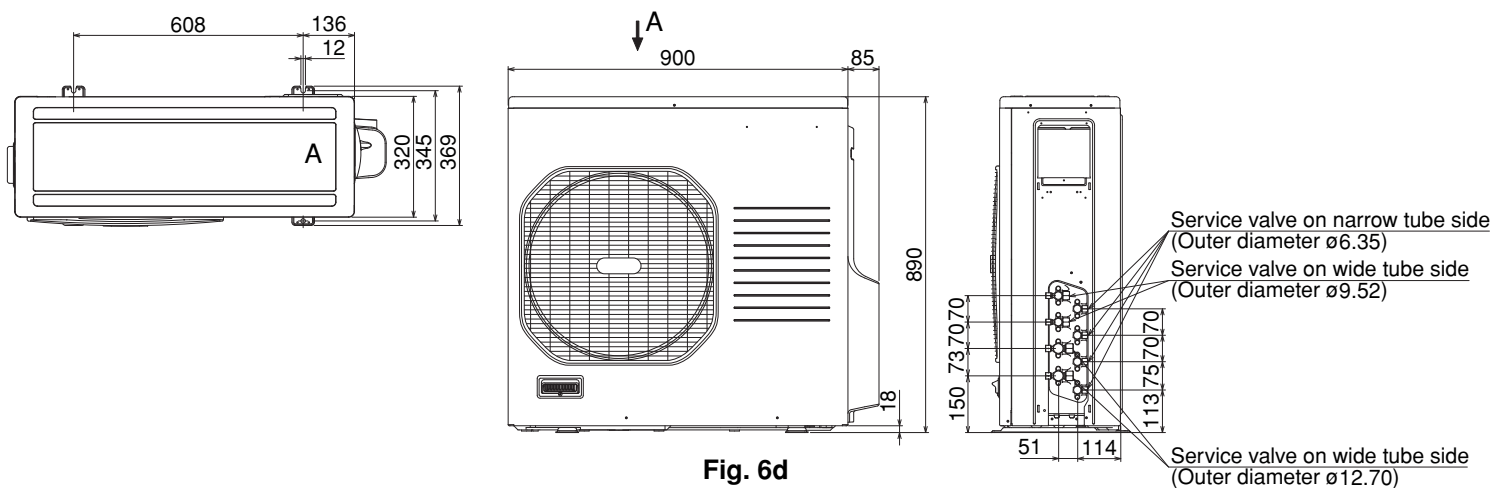

Fig. 6d

2-5. Diagram of Outdoor Unit Installation

Never install only a single indoor unit.

(1) AE2MI40AH

Be sure to connect indoor and outdoor units only in combinations that are listed in the catalog or in the combination table that was provided with the outdoor unit. (Use caution. Connecting any other model may result in operation failure and malfunction.)

The dimensions indicated by ⇔ in the figure below are spaces that are required in order to maintain performance. Install in a location where the dimensions indicated by ⇔ are ensured, and where 2 or more faces of the unit are unobstructed. In principle, the top direction should be unobstructed.

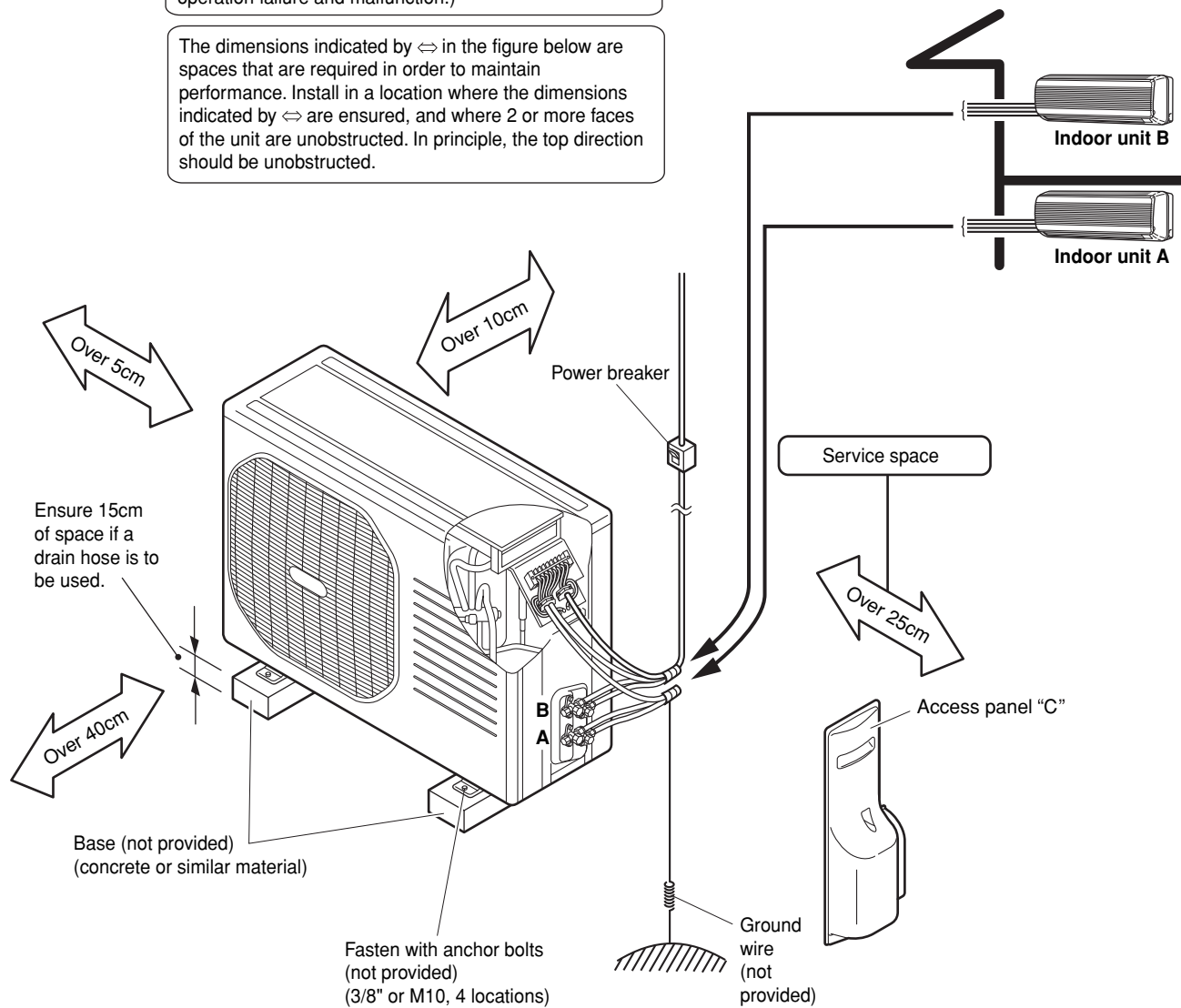

Fig. 6e

(2) AE2MI56AHB, AE3MI68AH, AE4MI80AH

Be sure to connect indoor and outdoor units only in combinations that are listed in the catalog or in the combination table that was provided with the outdoor unit. (Use caution. Connecting any other model may result in operation failure and malfunction.)

The dimensions indicated by ⇔ in the figure below are spaces that are required in order to maintain performance. Install in a location where the dimensions indicated by ⇔ are ensured, and where 2 or more faces of the unit are unobstructed. In principle, the top direction should be unobstructed.

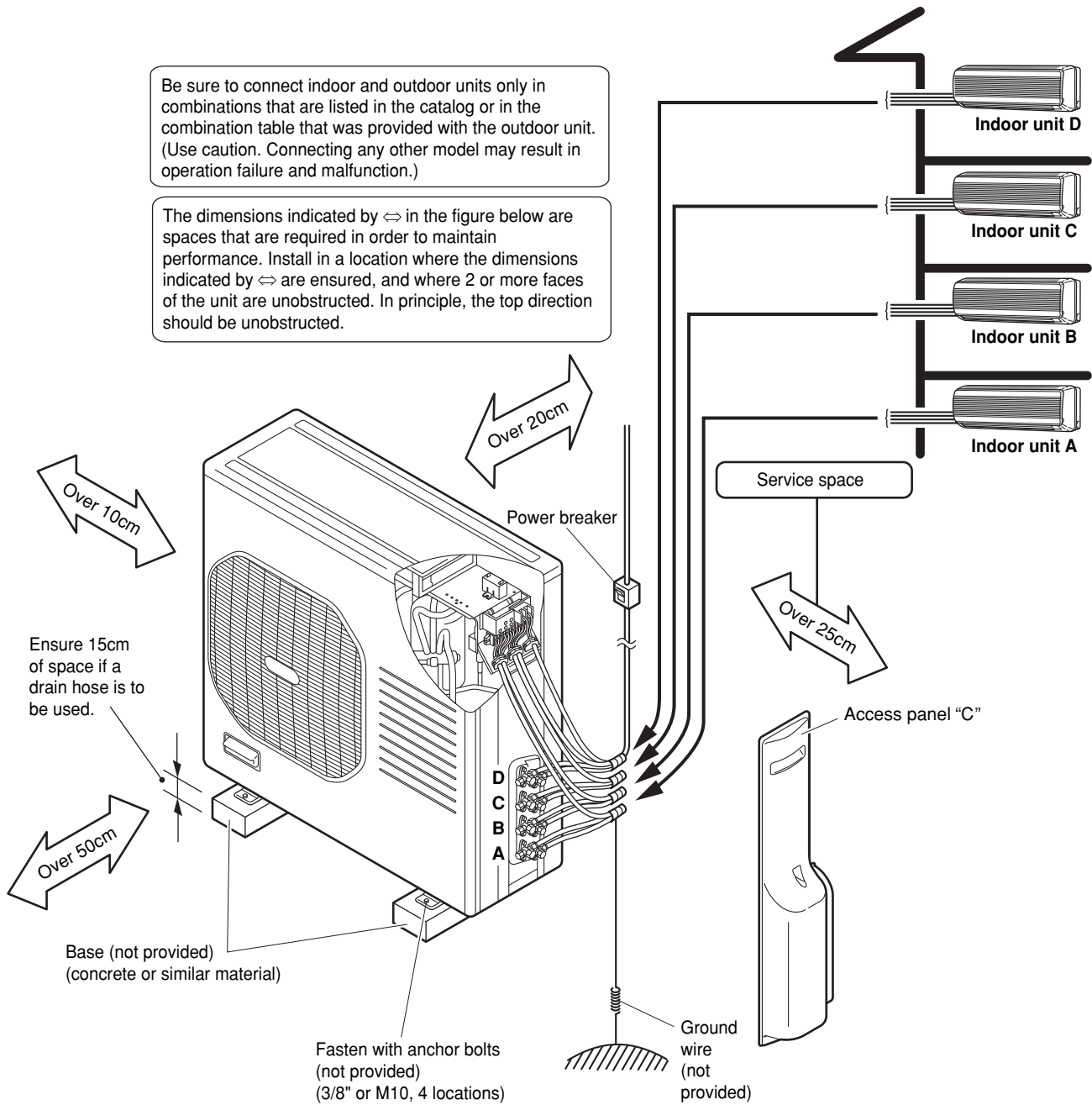

Fig. 6f

3. Installation Process

3-1. Embedding the Tubing and Wiring

- Do not connect tubes to locations that are embedded.
- Be sure to bind refrigerant tubing and inter-unit cables together with vinyl tape.
- The power cable must be obtained on-site.
($\phi 3.5$: Less than 26 m)
- Be sure to apply the provided labels to both ends of the inter-unit cables to prevent miswiring.
- Securely seal the end of embedded tubing with vinyl tape in order to prevent dirt or moisture entry.
- In order to prevent insulation breakdown and ground faults, do not allow the wire ends to contact rainwater, or be subject to dew condensation.

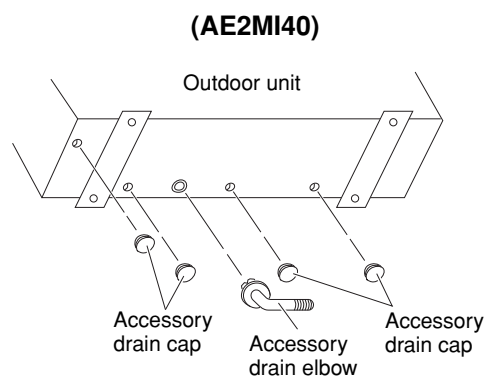

Fig. 7a

3-2. Drain Cap and Drain Elbow

First refer to Section 2. Installation Site Selection.

NOTE

The drain hole at the bottom of the outdoor unit was not plugged at the time of factory shipment. If necessary, plug the drain hole with the accessory drain cap or mount the accessory drain elbow before installing the outdoor unit. (Fig. 7a or 7b)



CAUTION

When installing in a cold area where drainage water may freeze, do not attach the provided drain cap or drain elbow to the bottom plate of the unit.

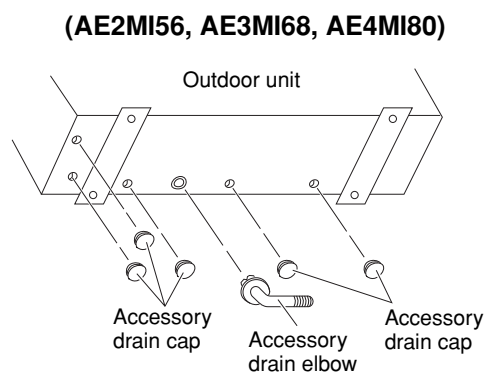

Fig. 7b

3-3. Use of the Flaring Method

Many of the conventional split system air conditioners employ the flaring method to connect refrigerant tubes which run between indoor and outdoor units. In this method, the copper tubes are flared at each end and connected with flare nuts.

3-4. Flaring Procedure with a Flare Tool

- (1) Cut the copper tube to the required length with a tube cutter. It is recommended to cut approx. 30 – 50 cm longer than the tubing length you estimate.
- (2) Remove burrs at the end of the copper tube with a tube reamer or file. This process is important and should be done carefully to make a good flare. (Fig. 8)

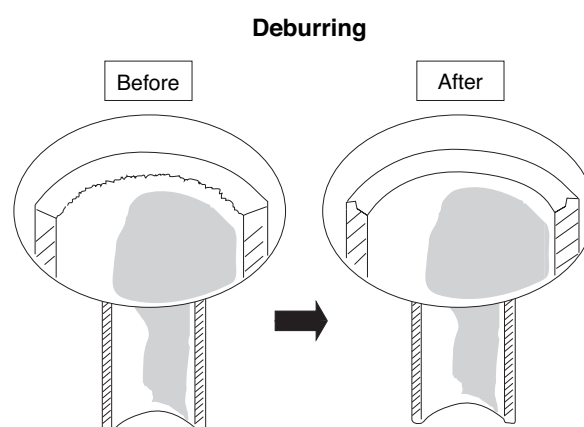

Fig. 8

NOTE

When reaming, hold the tube end downward and be sure that no copper scraps fall into the tube. (Fig. 9)

- (3) Remove the flare nut from the unit and be sure to mount it on the copper tube.
 - (4) Make a flare at the end of copper tube with a flare tool.* (Figs. 10 and 11)
- (*Use "RIDGID" or equivalent.)

NOTE

A good flare should have the following characteristics:

- inside surface is glossy and smooth.
- edge is smooth.
- tapered sides are of uniform length.

3-5. Caution Before Connecting Tubes Tightly

- a) Be sure to apply a sealing cap or water-proof tape to prevent dust or water from getting into the tubes before they are used.
- b) Be sure to apply refrigerant lubricant to the matching surfaces of the flare and union before connecting them together. This is effective for reducing gas leaks. (Fig. 12)
- c) For proper connection, align the union tube and flare tube straight with each other, then screw in the flare nut lightly at first to obtain a smooth match. (Fig. 13)

3-6. Tubing Connections

- a) Temporary connection:
Screw in 3 – 5 rotations by hand. (Fig.14)
- b) To fasten the flare nuts, apply specified torque as:

Table 4

Tube Dia.	Tightening Torque
6.35 mm	14 – 18 N·m (140 – 180 kgf · cm)
9.52 mm	34 – 42 N·m (340 – 420 kgf · cm)
12.70 mm	49 – 61 N·m (490 – 610 kgf · cm)
15.88 mm	68 – 82 N·m (680 – 820 kgf · cm)

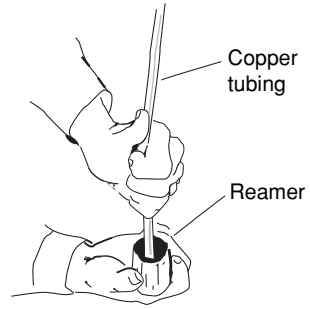
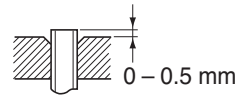
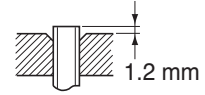

Fig. 9

If the special R410A flare tool is used:



If the previous flare tool (clutch-type) is used:



Adjust so that the amount of tube protrusion is as shown in the figure.

Fig. 10

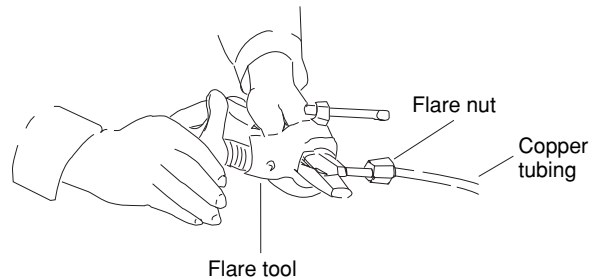

Fig. 11

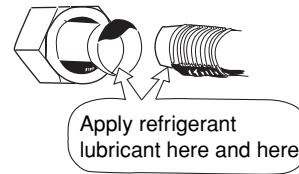

Fig. 12

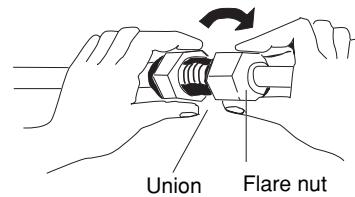

Fig. 13

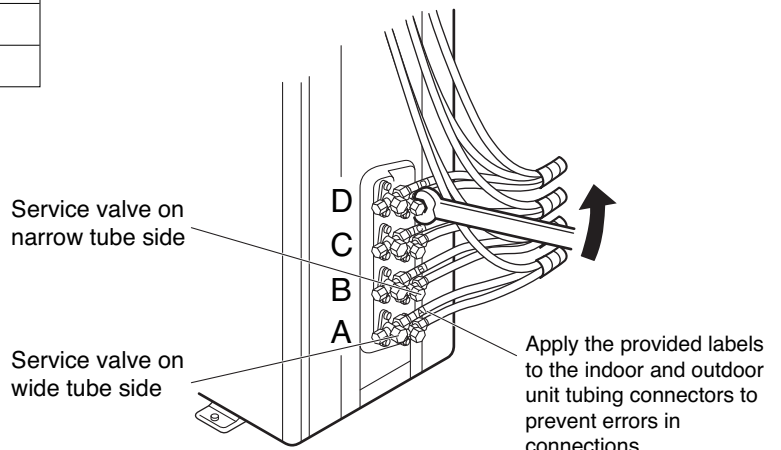
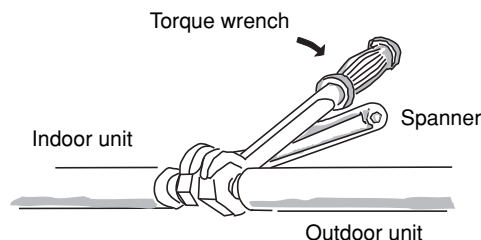

Fig. 14

**CAUTION**

Be sure to match refrigerant tubing and electric wiring between indoor and outdoor units. For more details, refer to “Tubing Check Control” in the Technical & Service Manual.

**Fig. 15****3-7. Insulation of Refrigerant Tubing****IMPORTANT**

To prevent heat loss and wet floors due to dripping of condensation, **both tubes must be well insulated with a proper insulation material.**

The thickness of the insulation should be a minimum 8 mm. (Fig. 17)

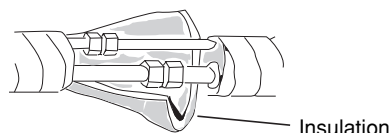
**Fig. 16****3-8. Taping the Tubes****CAUTION**

After a tube has been insulated, never try to bend it into a narrow curve, as this may cause the tube to break or crack.

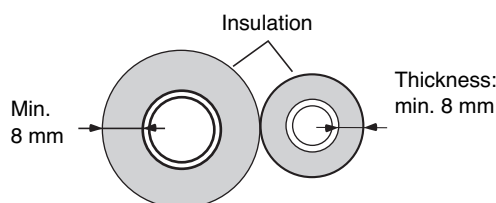
**Fig. 17**

- (1) At this time, the 2 refrigerant tubes (and electrical wire if local codes permit) should be taped together with armoring tape. The drain hose may also be included and taped together as 1 bundle with the tubing.
- (2) Wrap the armoring tape from the bottom of the outdoor unit to the top of the tubing where it enters the wall. As you wrap the tubing, overlap half of each previous tape turn. (Fig. 18)
- (3) Clamp the tubing bundle to wall, using 1 clamp approx. every 120 cm.

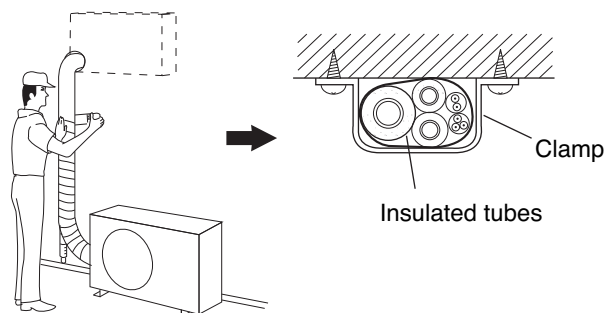
**Fig. 18****NOTE**

Do not wind the armoring tape too tightly, since this will decrease the heat insulation effect. Also, be sure the condensation drain hose splits away from the bundle and drips clear of the unit and the tubing.

3-9. Finishing the Installation

After finishing insulating and taping over the tubing, use sealing putty to seal off the hole in the wall to prevent rain and draft from entering. (Fig. 19)

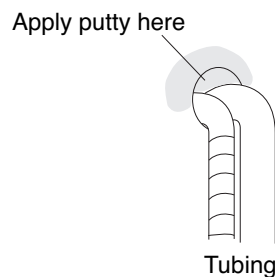
**Fig. 19**

4. Air Purging

Air and moisture remaining in the refrigerant system have undesirable effects as indicated below. Therefore, they must be purged completely.

- pressure in the system rises
- operating current rises
- cooling efficiency drops
- moisture in the air may freeze and block capillary tubing
- water may lead to corrosion of parts in the refrigerant system

■ Air Purging with a Vacuum Pump (for Test Run)

- In order to protect the earth's environment, be sure to use a vacuum pump to perform the air purge. (Never perform an air purge by using the refrigerant gas cylinder or other external gas, or by using the gas inside the outdoor unit.)
- Perform the air purge for tubes A, B, C, and D. Use the same procedures for all tubes.

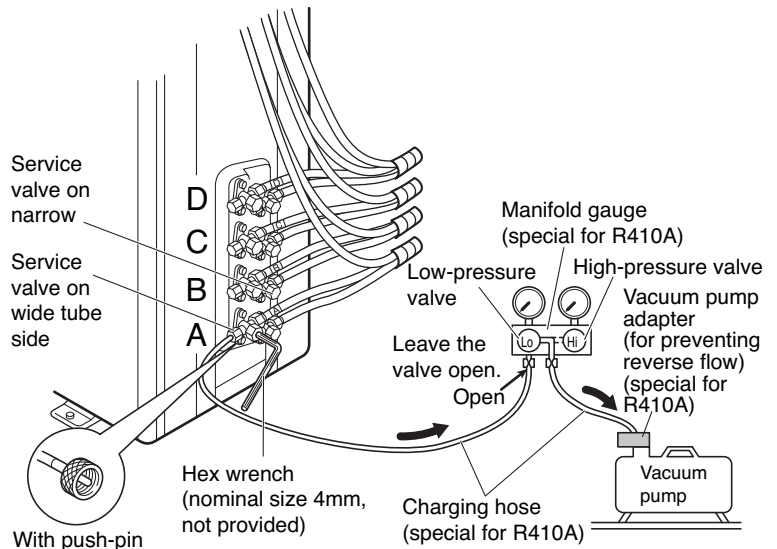

Fig. 20



CAUTION

In order to prevent charging errors with Air Conditioner that uses R410A, the screw diameter at the service valve charging port has been changed. When recharging or performing other servicing, use the special charging hose and manifold gauge.

- (1) Check that each tube (both narrow and wide tubes) between the indoor and outdoor units have been properly connected and all wiring for the test run has been completed. Note that both narrow and wide tube service valves on the outdoor unit are kept closed at this stage.
- (2) Using an adjustable wrench or box wrench, remove the valve caps from the service valve on both narrow and wide tubes.
- (3) Connect a vacuum pump and a manifold valve (with pressure gauges) to the service port on the wide tube service valve. (Fig. 20).

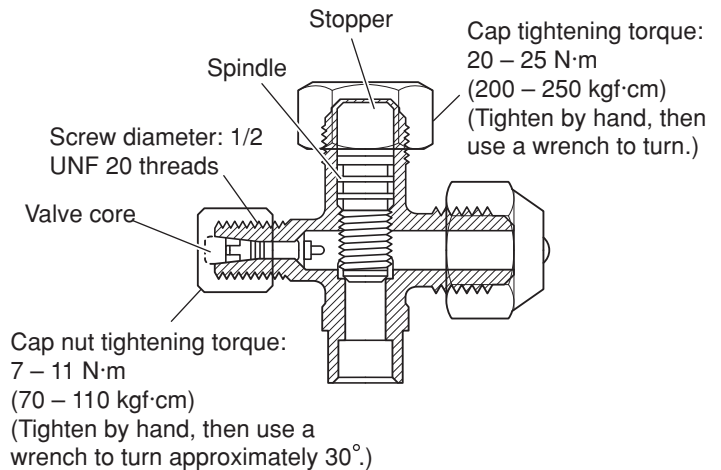

<Structure of service valve on wide tube side>

Fig. 21



CAUTION

Before using the vacuum pump adapter, read the vacuum pump adapter manual, and use the adapter correctly.



CAUTION

Be sure to use a manifold valve for air purging. If it is not available, use a stop valve for this purpose. The "Hi" knob of the manifold valve must always be kept closed.

- When using a hex wrench to open the spindle, an extremely small amount of refrigerant may leak. This does not indicate a problem.
- Use a hex wrench of a type to which force can be easily applied.

- (4) With the “Lo” knob of the manifold valve open and high-pressure valve (“Hi”) closed completely, run the vacuum pump. Run the pump until the pressure is -101 kPa (-76 cmHg). The operation time for the vacuum pump varies with tubing length and the capacity of the pump. The following table shows the amount of time required for evacuation:

Table 5

Required time for evacuation when capacity of 100 liter/h vacuum pump is used
20 min. or more

NOTE

The required time in the above table is calculated based on the assumption that the ideal (or target) vacuum condition is around 10 mmHg abs.

- (5) With the vacuum pump still running, close the “Lo” knob of the manifold valve. Then stop the vacuum pump. Fully close the low-pressure valve and stop the vacuum pump. (Wait 1 – 2 minutes and check that the manifold gauge pointer does not return. If it does return, find and repair the leak, then apply the vacuum again.)
- (6) With a hex wrench, turn the valve stem on the narrow tube service valve counter-clockwise by 90 degrees ($1/4$ turn) for 10 seconds, and then turn the stem clockwise to close it again.



CAUTION

Be sure to completely insert the hex wrench before attempting to turn the valve.

- (7) With a standard screwdriver, turn the wide tube service valve stem counterclockwise to fully open the valve.
- (8) Turn the narrow tube service valve stem counterclockwise to fully open the valve.
- (9) Loosen the vacuum hose connected to the wide tube service port slightly to release the pressure. Then, remove the hose.
- (10) Leak test all joints at the tubing (both indoor and outdoors) with liquid soap. Bubbles indicate a leak. Be sure to wipe off the soap with a clean cloth.



CAUTION

If a CFC gas detector is used, use a special detector for HFC refrigerant (such as R410A and R134a).

- (11) Replace the flare nut on the wide tube service port and fasten the flare nut securely with an adjustable wrench or box wrench. Next, mount the valve cap and tighten it with a torque wrench (the cap needs to be tightened with the torque of 20 N·m (200 kgf · cm)). This process is very important to prevent gas from leaking from the system.
- (12) Test run the air conditioner. (See page 23.)
- (13) While the air conditioner is running, apply liquid soap to check for any gas leaks around the service valves or caps.
- (14) If there is no leakage, stop the air conditioner.
- (15) Wipe off the soap on the tubing.

This completes air purging with a vacuum pump and the air conditioner is ready for actual operation.

■ Pump Down

In order to protect the earth's environment, be sure to perform pump-down to recover refrigerant gas without releasing it into the atmosphere.

- When relocating or disposing of the Air Conditioner, request this service from the dealer where the unit was purchased, or from an appropriate agent. Perform pump-down as described below.

What is pump-down?

- Pump-down refers to recovering the refrigerant gas from the refrigerant cycle at the outdoor unit. This work must be performed during cooling operation. The refrigerant gas cannot be recovered during heating operation.
- During winter, or if the temperature sensor prevents cooling operation, perform "forced cooling operation."

Pump-down procedure

- (1) Fully close the spindles at the valves on the narrow tube side of tubes A, B, C and D. (Refer to Fig. 22.)
- (2) Connect the manifold gauge to the charging port at the valve on the wide tube side of tube D. Purge the air from the charging hose. (Refer to Fig. 23.)
- (3) Perform cooling operation or forced cooling operation. When the pressure at the low-pressure side is 0.15 – 0.2 MPa (0.5 – 1 kg/cm²G), fully close the spindles at the valves on the wide tube side of tubes A, B, C, and D, and immediately stop operation. (Refer to Fig. 23.)
In the winter, the outdoor unit may stop after 5 - 10 minutes of operation. This is in order to protect the indoor unit heat exchanger from freezing and does not indicate a problem.
- (4) Disconnect the manifold gauge and the inter-unit tubes, and attach the caps and flare nuts. At this point, pump-down is completed. (If the caps and flare nuts are not reattached, there is the danger of gas leakage.) (Refer to Fig. 24.)

If pump-down is not possible

If the Air Conditioner cannot be operated because of a malfunction or other cause, use a refrigerant recovery device to recover the refrigerant.

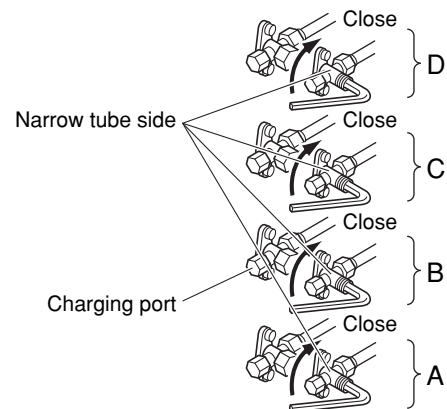

Fig. 22

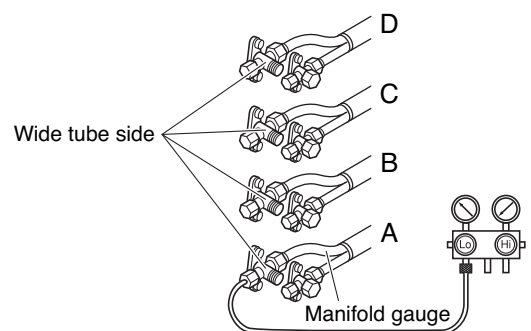

Fig. 23

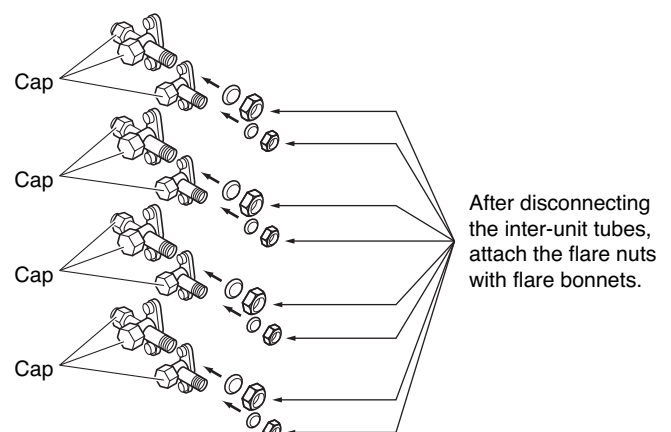

Fig. 24

5. Wiring Instructions

5-1. General Precautions on Wiring

- (1) Before wiring, confirm the rated voltage of the unit as shown on its nameplate, then carry out the wiring closely following the wiring diagram.
- (2) Provide a power outlet to be used exclusively for each unit, with a power supply disconnect and circuit breaker for overcurrent protection provided in the exclusive line.
- (3) To prevent possible hazard due to insulation failure, the unit must be grounded.
- (4) Each wiring connection must be done tightly and in accordance with the wiring system diagram. Wrong wiring may cause the unit to misoperate or become damaged.
- (5) Do not allow wiring to touch the refrigerant tubing, compressor, or any moving parts of the fan.
- (6) Unauthorized changes in the internal wiring can be very dangerous. The manufacturer will accept no responsibility for any damage or misoperation that occurs as a result of such unauthorized changes.

5-2. Recommended Wire Length and Diameter

Regulations on wiring diameter differ from locality to locality. For field wiring requirements, please refer to your local electrical codes. Carefully observe these regulations when carrying out the installation.

Table 6 shows maximum wire lengths for control line and power line and fuse or circuit capacity.

NOTE

Refer to the wiring system diagram (Fig. 25a or 25b) for the meaning of (A), (B), and (C) in Table 6.

Table 6

Model	Cross-Sectional Area (mm ²)	Max. Power Line Length (m)	Max. Control Line Length (m)	Fuse or Circuit Capacity
		(A)	(B) (C)	
		3.5	1.0	
AE2MI40		26	25	20 A
AE2MI56		26	25	20 A
AE3MI68		26	25	20 A
AE4MI80		26	30	20 A



WARNING

- Be sure to comply with local codes on running the wire from the indoor unit to the outdoor unit (size of wire and wiring method, etc.).
- Each wire must be firmly connected.
- No wire should be allowed to touch refrigerant tubing, the compressor, or any moving part.
- Be sure to connect power wires correctly matching up numbers on terminals of the outdoor unit and respective indoor units A – D.



CAUTION

- Be sure to connect the power supply line to the outdoor unit as shown in the wiring diagram. The indoor unit draws its power from the outdoor unit.
- Do not run wiring for antenna, signal, or power lines of television, radio, stereo, telephone, security system, or intercom any closer than 1 meter from the power cable and wires between the indoor and outdoor units. Electrical noise may affect the operation.



WARNING

- To avoid the risk of electric shock, each air conditioner unit must be grounded.
- For the installation of a grounding device, please observe local electrical codes.
- Grounding is necessary, especially for units using inverter circuits, in order to release charged electricity and electrical noise caused by high tension. Otherwise, electrical shock may occur.
- Place a dedicated ground more than 2 meters away from other grounds and do not have it shared with other electric appliances.

5-3. Wiring System Diagram

2 indoor units with AE2MI40, AE2MI56

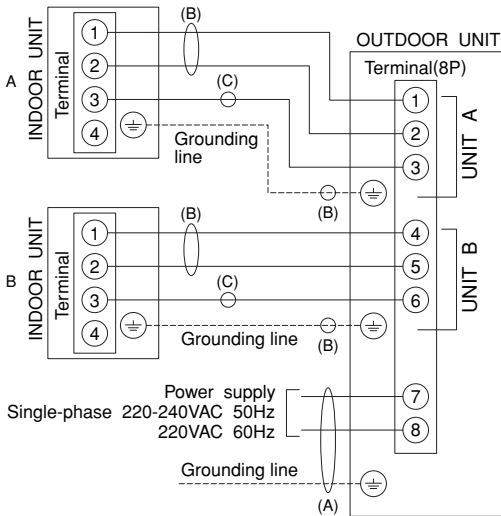

Fig. 25a

4 indoor units with AE3MI68, AE4MI80

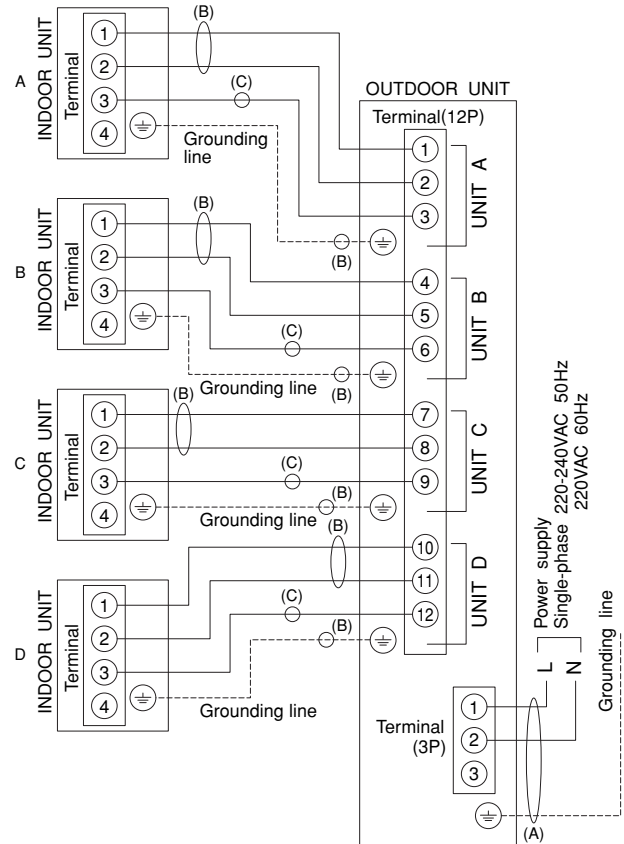

Fig. 25b

5-4. How to Connect Wiring to the Terminal



WARNING

Loose wiring may cause the terminal to overheat or result in unit malfunction. A fire hazard may also exist. Therefore, be sure all wiring is tightly connected.

When connecting each power wire to the corresponding terminal, follow the instructions “How to connect wiring to the terminal” and fasten the wire securely tight with the fixing screw of the terminal plate.

How to connect wiring to the terminal

a) For Indoor Unit

- (1) Cut the wire end with a cutting pliers, then strip the insulation to expose the wire about 7 mm. See the label (Fig. 26) near the terminal plate.
- (2) Using a screwdriver, loosen the terminal screw on the terminal plate.
- (3) Insert the wire and tighten the terminal screw completely using a screwdriver.

b) For Outdoor Unit

■ For solid core wiring (or F-cable)

- (1) Cut the wire end with a cutting pliers, then strip the insulation to expose the solid wire about 25 mm. (Fig. 27)
- (2) Using a screwdriver, remove the terminal screw(s) on the terminal plate.
- (3) Using the pliers, bend the solid wire to form a loop suitable for the terminal screw.
- (4) Shape the loop wire properly, place it on the terminal plate and fix it securely with the removed terminal screw using a screwdriver.

■ For stranded wiring

- (1) Cut the wire end with a cutting pliers, then strip the insulation to expose the stranded wiring about 10 mm and tightly twist the wire ends. (Figs. 28 and 29)
- (2) Using a screwdriver, remove the terminal screw(s) on the terminal plate.
- (3) Using a ring connector fastener or pliers, securely clamp each stripped wire end with a ring connector. (Fig. 28)
- (4) Place the ring connector wire, and replace and tighten the removed terminal screw using a screwdriver. (Fig. 30)

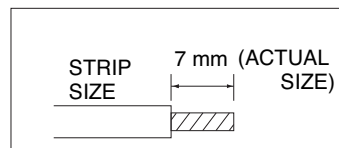

Fig. 26

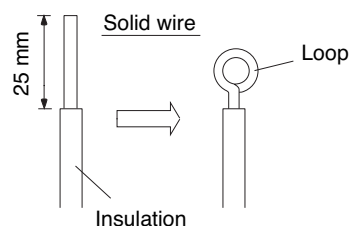

Fig. 27

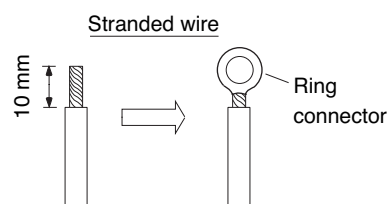

Fig. 28

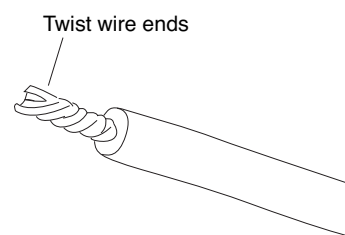

Fig. 29

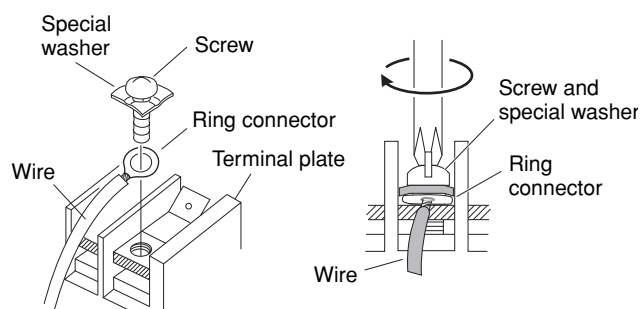

Fig. 30

5-5. Wiring Instructions for the Outdoor Unit



CAUTION

- Be sure to correctly align inter-unit cables A, B, C and D.

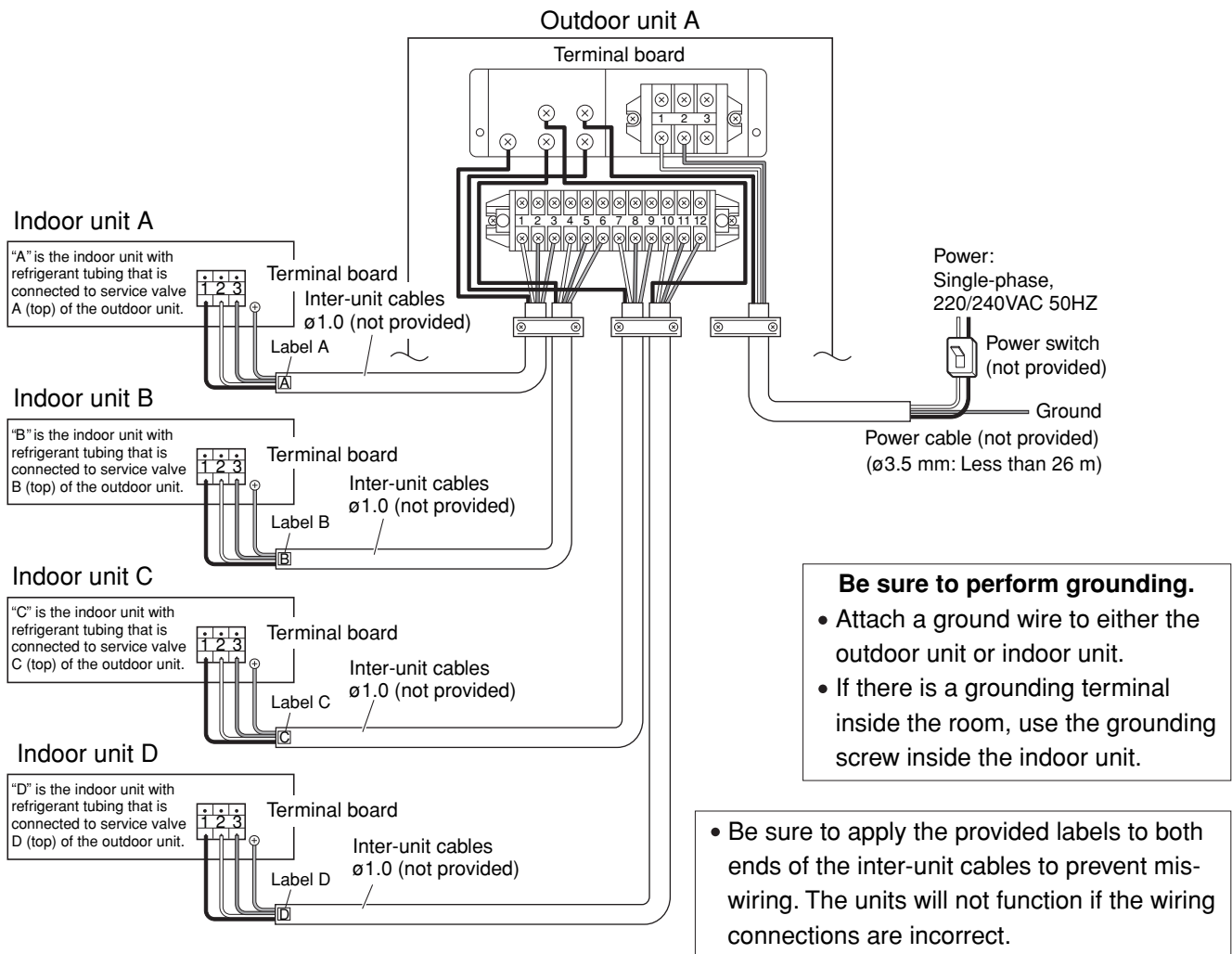

Fig. 31

- Use a dedicated Air Conditioner circuit for power.
- To make connections to the outdoor unit, remove the inspection panel and tubing panel.
- Do not bring the inter-unit cables or power cable into contact with tubing or service valves.
- Use outdoor unit cable fasteners and fasten the inter-unit cables at the location where the cables are double-sheathed.
- Arrange the wiring so that the inter-unit cables are contained in the inspection panel and tubing panel, as shown in Fig. 31.

Regulations on wire size differ from locality to locality. For field wiring requirements, please refer to your local electrical codes. Make sure that the installation fully complies with all local and national regulations.

- (1) Remove access panel "C". (Fig. 32)
- (2) Connect the inter-unit wiring and power line according to the drawing on the panel side.
- (3) Be sure to size each wire allowing approx. 10 cm longer than the required length for wiring. Store excess wiring inside the cabinet.
- (4) When connections are completed, check that all connections are correct as shown in the wiring system diagram on panel side.
- (5) Be sure to ground the unit according to your local codes.

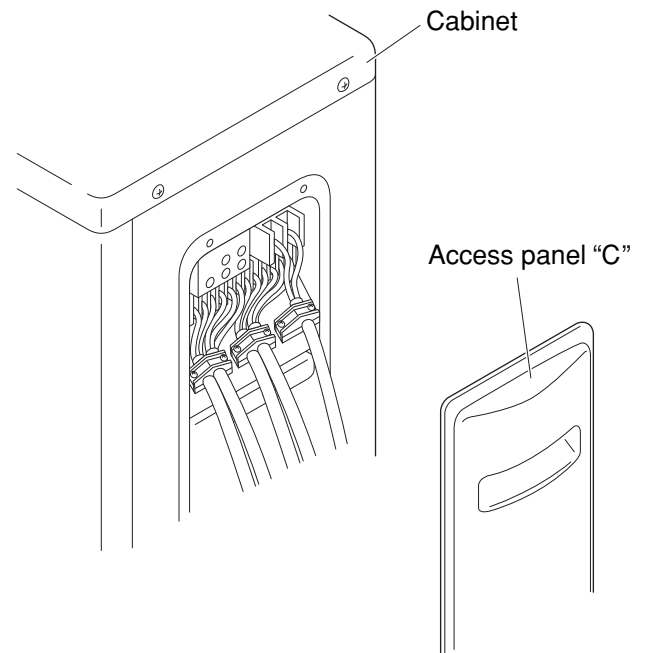

Fig. 32

6. Test Run

Performing a test run

- Refer to the test run procedures in the indoor unit installation manual.
- Perform the test run separately for each connected indoor unit. If 2 units are operated simultaneously, it is not possible to correctly check for errors in tubing and wiring.
- If the room temperature is 15°C or below, it may not be possible to check for tubing errors with cooling operation. If this occurs, perform heating operation for each unit individually, and check that warm air is discharged from each unit. If there is cold air mixed in with the warm air, check the tubing connections again.

Checking tubing and wiring

Perform the test run and check that operation is normal. If there is an error in tubing or wiring, the refrigerant may flow to indoor unit B when indoor unit A is operated (for example).



- Stop operation immediately if there is an error in tubing or wiring. Turn the power (breaker) to OFF, and check whether the inter-unit cables are connected incorrectly, or whether the narrow tubes A and B are connected in reverse. Correct the connections.
- If there is an error in tubing, pump-down must be performed. Be sure to perform pump-down. After making corrections, again purge the air from the tubes.

7. Connecting a Home Automation device

The HA (white) 4P terminal is located on the indoor unit PCB. If a HA device will be used, connect it to this terminal.

Also, refer to Section 9. ELECTRIC WIRING DIAGRAM in the outdoor unit installation manual.

8. Installation Check Sheet

- The strength of the installation location is sufficient to support the Air Conditioner weight.
- The indoor and outdoor units are installed level and vertically.
- The power and voltage are as specified.
- Inter-unit cables are securely fastened to the terminal board.
- Inter-unit cables are securely fixed.
- The power cord and inter-unit cables are not connected anywhere along their paths.
- The ground wire is securely connected.
- An air purge of the refrigerant circuit has been conducted.
- A leak test of the tubing connections has been performed.
- Thermal insulation has been applied to the tubing connections.
- Drain connections are secure and water drains properly.
- Putty has been used to close the hole in the wall.
- All service valves are fully open.
- Remote controller signals are being positively received.

9. Electric Wiring Diagram Diagramma dei circuiti elettrici

Indoor unit
Unità interne

AWMI22/27/35

AWI52/68

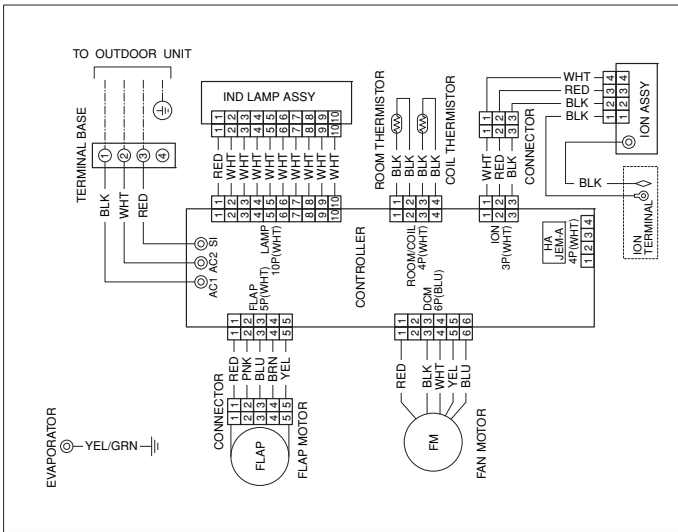

Fig. 33a

8FA-2-5257-72600-1

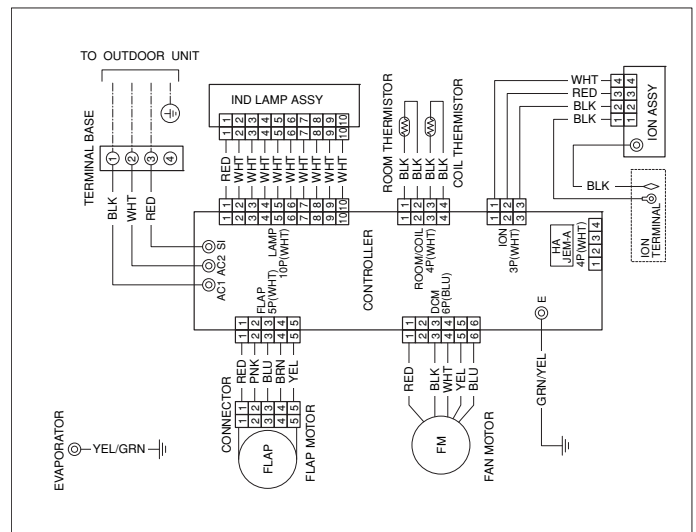

Fig. 33b

8FA-2-5257-68200-0

Electric wiring diagram for 2-room multi outdoor unit (AE2MI40) Diagramma dei circuiti elettrici per unità esterne multiple per 2 stanza (AE2MI40)

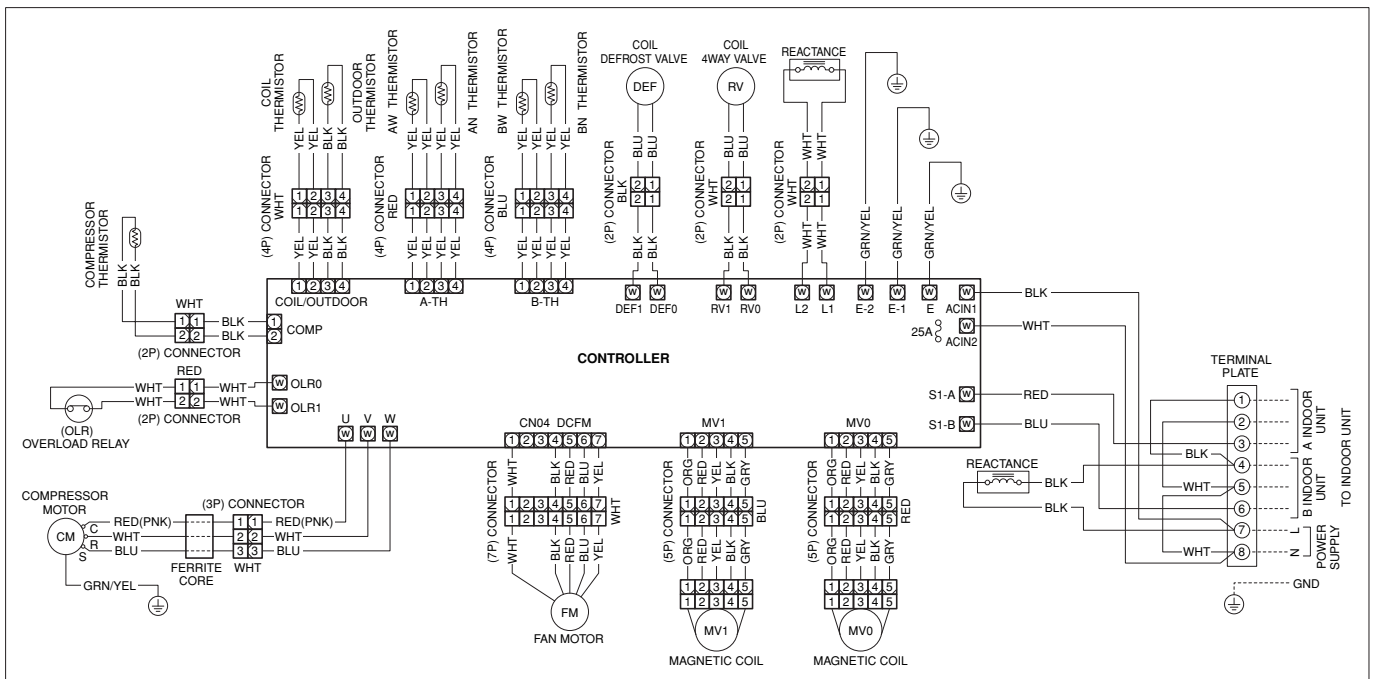

Fig. 34a

8FA-2-5257-56900-2



WARNING

To prevent electric shock, do not inspect or repair until the Power Lamp on the P.C.Board is turned off.



AVVERTIMENTO

Per evitare folgorazioni, non controllare o riparare fino a che l'indicatore di alimentazione della scheda circuiti stampati si è spento.

Meaning of Abbreviations

ABBREV.	MEANING
1 BLK	BLACK
2 BLU	BLUE
3 BRN	BROWN
4 GRN/YEL	GREEN/YELLOW
5 GRY	GREY
6 ORG	ORANGE
7 PNK	PINK
8 RED	RED
9 VLT	VIOLET
10 WHT	WHITE
11 YEL	YELLOW

Significato delle abbreviazioni

ABBREV.	SIGNIFICATO
1 BLK	NERO
2 BLU	BLU
3 BRN	MARRONE
4 GRN/YEL	VERDE/GIALLO
5 GRY	GRIGIO
6 ORG	ARANCIONE
7 PNK	ROSA
8 RED	ROSSO
9 VLT	VIOLA
10 WHT	BIANCO
11 YEL	GIALLO

Electric wiring diagram for 2-room multi outdoor unit (AE2MI56)
Diagramma dei circuiti elettrici per unità esterne multiple per 2 stanza (AE2MI56)

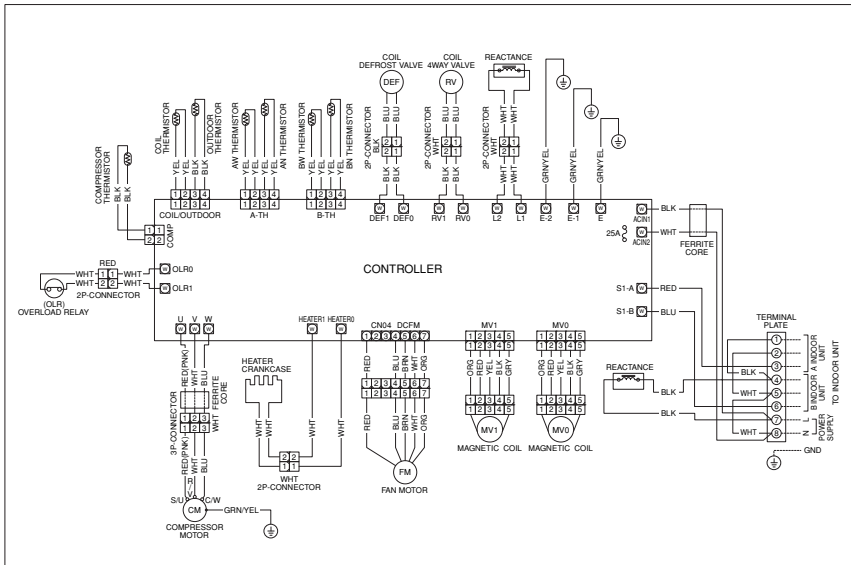

Fig. 34b

8FA-2-5257-84200-0

Meaning of Abbreviations

	ABBREV.	MEANING
1	BLK	BLACK
2	BLU	BLUE
3	BRN	BROWN
4	GRN/YEL	GREEN/YELLOW
5	GRY	GREY
6	ORG	ORANGE
7	PNK	PINK
8	RED	RED
9	VLT	VIOLET
10	WHT	WHITE
11	YEL	YELLOW

Electric wiring diagram for 4-room multi outdoor unit (AE3MI68)
Diagramma dei circuiti elettrici per unità esterne multiple per 4 stanza (AE3MI68)

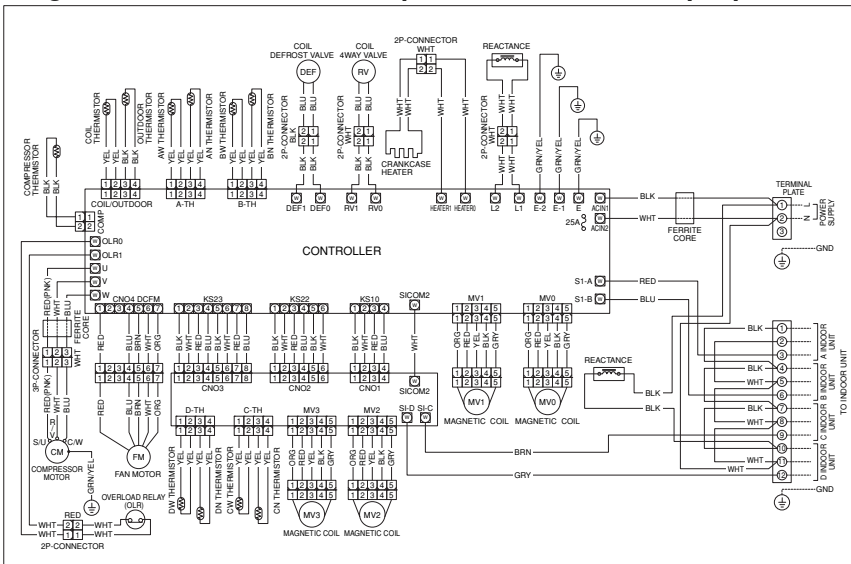

Fig. 34c

8FA-2-5257-57100-0

Significato delle abbreviazioni

	ABBREV.	SIGNIFICATO
1	BLK	NERO
2	BLU	BLU
3	BRN	MARRONE
4	GRN/YEL	VERDE/GIALLO
5	GRY	GRIGIO
6	ORG	ARANCIONE
7	PNK	ROSA
8	RED	ROSSO
9	VLT	VIOLA
10	WHT	BIANCO
11	YEL	GIALLO

Electric wiring diagram for 4-room multi outdoor unit (AE4MI80)
Diagramma dei circuiti elettrici per unità esterne multiple per 4 stanza (AE4MI80)

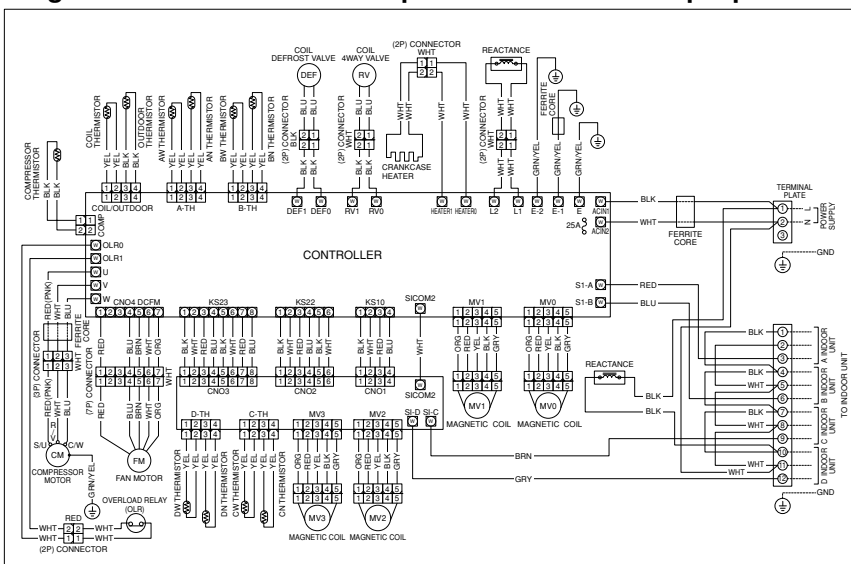

Fig. 34d

8FA-2-5257-89000-0

APPENDIX B UNIT COMBINATION TABLES

< List of Combination Table >

Name of Combination Table	Model No. of Outdoor Unit	Remarks
2-Room Outdoor Unit Combination Table	AE2MI40AH	OI-852-6-4181-049-00-0
2-Room Outdoor Unit Combination Table	AE2MI56AHB	OI-852-6-4181-050-00-0
4-Room Outdoor Unit Combination Table	AE3MI68AH	OI-852-6-4181-051-00-0
4-Room Outdoor Unit Combination Table	AE4MI80AH	OI-852-6-4181-052-00-0

NOTE

Be sure to operate the air conditioning system only when 2 or more indoor units have been installed. If operated with only a single unit installed, the returning fluid to the compressor may cause a malfunction.



2-Room Outdoor Unit Combination Table

AE2MI40AH

- Refer to the catalog for the combination indoor units.
- Store this table together with the operation manual supplied with the indoor unit.

<Combinations of Connectable Indoor Units>

The combinations of the indoor units listed in Table 1 on the next page are combinations solely of those units which can be operated concurrently. In addition to the combinations listed in the table, other combinations of indoor units are possible provided that the following conditions are satisfied.

Conditions:

1. At least two or more indoor units must be connected to the multi outdoor unit. It is not acceptable for only one indoor unit to be connected.
2. The total rated cooling capacity of the indoor units to be connected must be no more than 200% of the rated cooling capacity of the outdoor unit.



CAUTION

In this case, all the indoor units installed must not be operated concurrently under any circumstances. Otherwise, the air conditioner may not run properly and trouble may occur.

Example: When two indoor units are connected

If the following holds true

- Rated cooling capacity of AE2MI40AH outdoor unit: C=4 (kW)
- Rated cooling capacity of indoor units: K1, K2, ... (kW)

Then:

$$C \times 2 (200\%) \geq K1 + K2 + \dots$$

$$4 \times 2 \geq 3.5 + 3.5$$

$$8 \geq 7$$

It is therefore possible to connect two units with respective capacities of 3.5 + 3.5. However, since this combination is not found in the 2-room operation column of Table 1, operating all these units concurrently may result in trouble. At a time like this, shut down at least one of the two indoor units to match one of the combinations found in the single-room operation column of Table 1.

NOTE

Be sure to operate the air conditioning system only when 2 or more indoor units have been installed. If operated with only a single unit installed, the returning fluid to the compressor may cause a malfunction.

argoclima s.p.a.

Via Varese, 90 - 21013 Gallarate (VA) - Italy
Tel. +39 0331 755111 - Fax +39 0331 776240
<http://www.argoclima.com>

< Combinations of operatable indoor units >

AE2MI40AH

(Rated cooling capacity: 4.0 kW)

NOTE

2.2: AWWMI22AHL
 2.65: AWWMI27AHL
 3.5: AWWMI35AHL

Table 1

	Indoor Unit Combination		Indoor Unit Capacity (kW)							
			COOLING			HEATING				
			Room A	Room B	Total Performance		Room A	Room B	Total Performance	
					Capacity	(Min. - Max.)			Capacity	(Min. - Max.)
Single-room Operation	2.2	= 2.2	2.2		2.2 (1.2 - 2.6)	2.5		2.5 (1.4 - 3.5)		
	2.65	= 2.65	2.65		2.65 (1.2 - 3.2)	3.6		3.6 (1.4 - 4.0)		
	3.5	= 3.5	3.5		3.5 (1.3 - 3.6)	4.2		4.2 (1.5 - 4.2)		
2-room Operation	2.2 + 2.2	= 4.4	1.8	1.8	3.6 (2.0 - 4.5)	2.1	2.1	4.2 (2.0 - 5.0)		
	2.2 + 2.65	= 4.85	1.68	2.02	3.7 (2.0 - 4.8)	1.72	2.48	4.2 (2.0 - 5.0)		
	2.2 + 3.5	= 5.7	1.51	2.39	3.9 (2.0 - 4.9)	1.64	2.76	4.4 (2.2 - 5.3)		
	2.65 + 2.65	= 5.3	2	2	4.0 (2.0 - 5.0)	2.25	2.25	4.5 (2.2 - 5.5)		
	2.65 + 3.5	= 6.15	1.72	2.28	4.0 (2.1 - 5.0)	2.08	2.42	4.5 (2.4 - 5.5)		



2-Room Outdoor Unit Combination Table

AE2MI56AHB

- Refer to the catalog for the combination indoor units.
- Store this table together with the operation manual supplied with the indoor unit.

<Combinations of Connectable Indoor Units>

The combinations of the indoor units listed in Table 1 on the next page are combinations solely of those units which can be operated concurrently. In addition to the combinations listed in the table, other combinations of indoor units are possible provided that the following conditions are satisfied.

Conditions:

1. At least two or more indoor units must be connected to the multi outdoor unit. It is not acceptable for only one indoor unit to be connected.
2. The total rated cooling capacity of the indoor units to be connected must be no more than 200% of the rated cooling capacity of the outdoor unit.



CAUTION

In this case, all the indoor units installed must not be operated concurrently under any circumstances. Otherwise, the air conditioner may not run properly and trouble may occur.

Example: When two indoor units are connected

If the following holds true

- Rated cooling capacity of AE2MI56AHB outdoor unit: C=5.6 (kW)
- Rated cooling capacity of indoor units: K1, K2, ... (kW)

Then:

$$C \times 2 (200\%) \geq K1 + K2 + \dots$$

$$5.6 \times 2 \geq 5.15 + 5.15$$

$$11.2 \geq 10.3$$

It is therefore possible to connect two units with respective capacities of 5.15 + 5.15. However, since this combination is not found in the 2-room operation column of Table 1, operating all these units concurrently may result in trouble. At a time like this, shut down at least one of the two indoor units to match one of the combinations found in the single-room operation column of Table 1.

NOTE

Be sure to operate the air conditioning system only when 2 or more indoor units have been installed. If operated with only a single unit installed, the returning fluid to the compressor may cause a malfunction.

argoclima s.p.a.

Via Varese, 90 - 21013 Gallarate (VA) - Italy
Tel. +39 0331 755111 - Fax +39 0331 776240
<http://www.argoclima.com>

< Combinations of operatable indoor units >

AE2MI56AHB

(Rated cooling capacity: 5.6 kW)

NOTE

2.2: AWTI22AHL
 2.65: AWTI27AHL
 3.5: AWTI35AHL
 5.15: AWTI52AHL

Table 1

	Indoor Unit Combination		Indoor Unit Capacity (kW)					
			COOLING			HEATING		
			Room A	Room B	Total Performance Capacity (Min. - Max.)	Room A	Room B	Total Performance Capacity (Min. - Max.)
Single-room Operation	2.2	= 2.2	2.2		2.2 (1.4 - 2.6)	2.5		2.5 (1.8 - 4.3)
	2.65	= 2.65	2.65		2.65 (1.4 - 3.2)	3.6		3.6 (1.8 - 4.7)
	3.5	= 3.5	3.5		3.5 (1.5 - 3.6)	4.2		4.2 (1.9 - 5.1)
	5.15	= 5.15	5.15		5.15 (1.6 - 5.8)	6.0		6.0 (2 - 7.8)
2-room Operation	2.2 + 2.2	= 4.4	2.2	2.2	4.4 (2.0 - 5.1)	2.5	2.5	5.0 (2 - 6.4)
	2.2 + 2.65	= 4.85	2.2	2.65	4.85 (2.0 - 5.8)	2.5	3.6	6.1 (2.1 - 7.5)
	2.2 + 3.5	= 5.7	1.97	3.13	5.1 (2.0 - 6.7)	2.4	3.9	6.3 (2.1 - 8.3)
	2.2 + 5.15	= 7.35	1.65	3.85	5.5 (2.1 - 6.8)	2.03	4.87	6.9 (2.4 - 8.4)
	2.65 + 2.65	= 5.3	2.50	2.50	5 (2.0 - 6.3)	3.2	3.2	6.45 (2.3 - 8.4)
	2.65 + 3.5	= 6.15	2.24	2.96	5.2 (2.1 - 6.8)	3.07	3.58	6.65 (2.3 - 8.4)
	2.65 + 5.15	= 7.8	1.9	3.7	5.6 (2.1 - 6.8)	2.74	4.56	7.3 (2.4 - 8.4)
3.5 + 3.5	= 7	2.7	2.7	5.4 (2.0 - 6.8)	3.45	3.45	6.9 (2.3 - 8.4)	
3.5 + 5.15	= 8.65	2.27	3.33	5.6 (2.1 - 6.8)	3.01	4.29	7.3 (2.4 - 8.4)	



4-Room Outdoor Unit Combination Table

AE3MI68AH

- Refer to the catalog for the combination indoor units.
- Store this table together with the operation manual supplied with the indoor unit.

<Combinations of Connectable Indoor Units>

The combinations of the indoor units listed in Table 1 on the next page are combinations solely of those units which can be operated concurrently. In addition to the combinations listed in the table, other combinations of indoor units are possible provided that the following conditions are satisfied.

Conditions:

1. At least two or more indoor units must be connected to the multi outdoor unit. It is not acceptable for only one indoor unit to be connected.
2. The total rated cooling capacity of the indoor units to be connected must be no more than 200% of the rated cooling capacity of the outdoor unit.



CAUTION

In this case, all the indoor units installed must not be operated concurrently under any circumstances. Otherwise, the air conditioner may not run properly and trouble may occur.

Example: When four indoor units are connected

If the following holds true

- Rated cooling capacity of AE3MI68AH outdoor unit: C=6.8 (kW)
- Rated cooling capacity of indoor units: K1, K2, ... (kW)

Then:

$$C \times 2 (200\%) \geq K1 + K2 + \dots$$
$$6.8 \times 2 \geq 2.2 + 2.2 + 2.2 + 5.15$$
$$13.6 \geq 11.75$$

It is therefore possible to connect four units with respective capacities of 2.2 + 2.2 + 2.2 + 5.15. However, since this combination is not found in the 4-room operation column of Table 1, operating all these units concurrently may result in trouble. At a time like this, shut down at least one of the four indoor units to match one of the combinations found in the 3-room operation column of Table 1.

NOTE

Be sure to operate the air conditioning system only when 2 or more indoor units have been installed. If operated with only a single unit installed, the returning fluid to the compressor may cause a malfunction.

argoclima s.p.a.

Via Varese, 90 - 21013 Gallarate (VA) - Italy
Tel. +39 0331 755111 - Fax +39 0331 776240
<http://www.argoclima.com>



4-Room Outdoor Unit Combination Table

AE4MI80AH

- Refer to the catalog for the combination indoor units.
- Store this table together with the operation manual supplied with the indoor unit.

<Combinations of Connectable Indoor Units>

The combinations of the indoor units listed in Table 1 on the next page are combinations solely of those units which can be operated concurrently. In addition to the combinations listed in the table, other combinations of indoor units are possible provided that the following conditions are satisfied.

Conditions:

1. At least two or more indoor units must be connected to the multi outdoor unit. It is not acceptable for only one indoor unit to be connected.
2. The total rated cooling capacity of the indoor units to be connected must be no more than 200% of the rated cooling capacity of the outdoor unit.



CAUTION

In this case, all the indoor units installed must not be operated concurrently under any circumstances. Otherwise, the air conditioner may not run properly and trouble may occur.

Example: When four indoor units are connected

If the following holds true

- Rated cooling capacity of AE4MI80AH outdoor unit: C=8 (kW)
- Rated cooling capacity of indoor units: K1, K2, ... (kW)

Then:

$$C \times 2 (200\%) \geq K1 + K2 + \dots$$

$$8 \times 2 \geq 2.2 + 2.2 + 3.5 + 7.1$$

$$16 \geq 15$$

It is therefore possible to connect four units with respective capacities of 2.2 + 2.2 + 3.5 + 7.1. However, since this combination is not found in the 4-room operation column of Table 1, operating all these units concurrently may result in trouble. At a time like this, shut down at least one of the four indoor units to match one of the combinations found in the 3-room operation column of Table 1.

NOTE

Be sure to operate the air conditioning system only when 2 or more indoor units have been installed. If operated with only a single unit installed, the returning fluid to the compressor may cause a malfunction.

argoclima s.p.a.

Via Varese, 90 - 21013 Gallarate (VA) - Italy
Tel. +39 0331 755111 - Fax +39 0331 776240
<http://www.argoclima.com>

< Combinations of operatable indoor units >

AE4MI80AH

(Rated cooling capacity: 8.0 kW)

NOTE

2.2: AWWMI22AHL
 2.65: AWWMI27AHL
 3.5: AWWMI35AHL
 5.15: AWWMI52AHL
 7.1: AWWMI68AHL

Table 1

	Indoor Unit Combination	Indoor Unit Capacity (kW)															
		COOLING					HEATING										
		Room A	Room B	Room C	Room D	Total Performance			Room A	Room B	Room C	Room D	Total Performance				
					Capacity	Min.	-	Max.						Capacity	Min.	-	Max.
Single-room Operation	2.2	= 2.2	2.2				2.2	(1.5 - 2.6)		2.5				2.5	(1.8 - 4.3)		
	2.65	= 2.65	2.65				2.65	(1.5 - 3.2)		3.6				3.6	(1.8 - 4.7)		
	3.5	= 3.5	3.5				3.5	(1.6 - 3.6)		4.2				4.2	(1.9 - 5.1)		
	5.15	= 5.15	5.15				5.15	(1.7 - 5.8)		6				6	(2.0 - 7.8)		
	7.1	= 7.1	7.1				7.1	(1.8 - 7.4)		8.5				8.5	(2.0 - 8.8)		
2-room Operation	2.2 + 2.2	= 4.4	2.2	2.2			4.4	(2.0 - 5.1)		2.5	2.5			5	(2.0 - 6.4)		
	2.2 + 2.65	= 4.85	2.2	2.65			4.85	(2.0 - 5.8)		2.5	3.6			6.1	(2.1 - 7.5)		
	2.2 + 3.5	= 5.7	2.2	3.5			5.7	(2.0 - 6.7)		2.5	4.2			6.7	(2.3 - 8.3)		
	2.2 + 5.15	= 7.35	2.14	5.01			7.15	(2.2 - 7.7)		2.5	6			8.5	(3.0 - 9.4)		
	2.2 + 7.1	= 9.3	1.81	5.84			7.65	(2.3 - 8.8)		2.01	6.84			8.85	(3.0 - 9.8)		
	2.65 + 2.65	= 5.3	2.65	2.65			5.3	(2.0 - 6.5)		3.6	3.6			7.2	(2.4 - 8.5)		
	2.65 + 3.5	= 6.15	2.54	3.36			5.9	(2.0 - 7.4)		3.51	4.09			7.6	(2.6 - 8.5)		
	2.65 + 5.15	= 7.8	2.46	4.79			7.25	(2.3 - 8.5)		3.24	5.41			8.65	(3.3 - 9.4)		
	2.65 + 7.1	= 9.75	2.11	5.64			7.75	(2.3 - 8.8)		2.68	6.32			9	(3.3 - 9.8)		
	3.5 + 3.5	= 7	3.4	3.4			6.8	(2.2 - 8.4)		4	4			8	(2.9 - 8.5)		
	3.5 + 5.15	= 8.65	3.03	4.47			7.5	(2.6 - 8.8)		3.6	5.15			8.75	(3.4 - 9.8)		
	3.5 + 7.1	= 10.6	2.63	5.33			7.95	(2.6 - 8.8)		3.02	6.12			9.14	(3.4 - 9.8)		
	5.15 + 5.15	= 10.3	3.95	3.95			7.9	(2.6 - 8.8)		4.5	4.5			9	(3.4 - 9.8)		
	5.15 + 7.1	= 12.3	3.36	4.64			8	(2.7 - 8.8)		3.89	5.51			9.4	(3.4 - 9.8)		
	3-room Operation	2.2 + 2.2 + 2.2	= 6.6	2.2	2.2	2.2		6.6	(2.0 - 7.7)		2.5	2.5	2.5		7.5	(2.7 - 9.0)	
2.2 + 2.2 + 2.65		= 7.05	2.2	2.2	2.65		7.05	(2.2 - 8.4)		2.47	2.47	3.56		8.5	(3.0 - 9.2)		
2.2 + 2.2 + 3.5		= 7.9	2.03	2.03	3.23		7.3	(2.4 - 8.6)		2.34	2.34	3.93		8.6	(3.2 - 9.8)		
2.2 + 2.2 + 5.15		= 9.55	1.77	1.77	4.15		7.7	(2.7 - 9.0)		2.01	2.01	4.83		8.85	(3.4 - 9.8)		
2.2 + 2.2 + 7.1		= 11.5	1.53	1.53	4.94		8	(2.9 - 9.0)		1.71	1.71	5.82		9.25	(3.4 - 9.8)		
2.2 + 2.65 + 2.65		= 7.5	2.11	2.54	2.54		7.2	(2.3 - 8.6)		2.23	3.21	3.21		8.65	(3.3 - 9.3)		
2.2 + 2.65 + 3.5		= 8.35	1.95	2.35	3.1		7.4	(2.6 - 9.0)		2.12	3.06	3.57		8.75	(3.4 - 9.8)		
2.2 + 2.65 + 5.15		= 10	1.72	2.07	4.02		7.8	(2.9 - 9.0)		1.86	2.68	4.46		9	(3.4 - 9.8)		
2.2 + 2.65 + 7.1		= 12	1.47	1.77	4.75		8	(2.9 - 9.0)		1.61	2.32	5.47		9.4	(3.4 - 9.8)		
2.2 + 3.5 + 3.5		= 9.2	1.82	2.89	2.89		7.6	(2.7 - 9.0)		2.03	3.41	3.41		8.85	(3.4 - 9.8)		
2.2 + 3.5 + 5.15		= 10.9	1.6	2.55	3.75		7.9	(2.9 - 9.0)		1.79	3.01	4.3		9.1	(3.4 - 9.8)		
2.2 + 3.5 + 7.1		= 12.8	1.38	2.19	4.44		8	(2.9 - 9.0)		1.55	2.6	5.26		9.4	(3.4 - 9.8)		
2.2 + 5.15 + 5.15		= 12.5	1.41	3.3	3.3		8	(2.9 - 9.0)		1.62	3.89	3.89		9.4	(3.4 - 9.8)		
2.2 + 5.15 + 7.1		= 14.5	1.22	2.85	3.93		8	(2.9 - 9.0)		1.38	3.32	4.7		9.4	(3.4 - 9.8)		
2.65 + 2.65 + 2.65		= 7.95	2.43	2.43	2.43		7.3	(2.5 - 8.6)		2.95	2.95	2.95		8.85	(3.4 - 9.4)		
2.65 + 2.65 + 3.5		= 8.8	2.26	2.26	2.98		7.5	(2.7 - 9.0)		2.81	2.81	3.28		8.9	(3.4 - 9.8)		
2.65 + 2.65 + 5.15		= 10.5	2.0	2.0	3.89		7.9	(2.9 - 9.0)		2.51	2.51	4.18		9.2	(3.4 - 9.8)		
2.65 + 2.65 + 7.1		= 12.4	1.71	1.71	4.58		8	(2.9 - 9.0)		2.16	2.16	5.09		9.4	(3.4 - 9.8)		
2.65 + 3.5 + 3.5		= 9.65	2.13	2.81	2.81		7.75	(2.7 - 9.0)		2.7	3.15	3.15		9	(3.4 - 9.8)		
2.65 + 3.5 + 5.15		= 11.3	1.88	2.48	3.65		8	(2.9 - 9.0)		2.43	2.83	4.04		9.3	(3.4 - 9.8)		
2.65 + 3.5 + 7.1		= 13.3	1.6	2.11	4.29		8	(2.9 - 9.0)		2.08	2.42	4.9		9.4	(3.4 - 9.8)		
2.65 + 5.15 + 5.15		= 13	1.64	3.18	3.18		8	(2.9 - 9.0)		2.17	3.62	3.62		9.4	(3.4 - 9.8)		
3.5 + 3.5 + 3.5		= 10.5	2.65	2.65	2.65		7.95	(2.9 - 9.0)		3.03	3.03	3.03		9.1	(3.4 - 9.8)		
3.5 + 3.5 + 5.15		= 12.2	2.3	2.3	3.39		8	(2.9 - 9.0)		2.73	2.73	3.9		9.35	(3.4 - 9.8)		
3.5 + 3.5 + 7.1		= 14.1	1.99	1.99	4.03		8	(2.9 - 9.0)		2.34	2.34	4.73		9.4	(3.4 - 9.8)		
3.5 + 5.15 + 5.15		= 13.8	2.03	2.99	2.99		8	(2.9 - 9.0)		2.44	3.48	3.48		9.4	(3.4 - 9.8)		
4-room Operation		2.2 + 2.2 + 2.2 + 2.2	= 8.8	1.88	1.88	1.88	1.88	7.5	(2.9 - 9.2)		2.18	2.18	2.18	2.18	8.7	(3.4 - 9.8)	
	2.2 + 2.2 + 2.2 + 2.65	= 9.25	1.82	1.82	1.82	2.19	7.65	(2.9 - 9.2)		1.99	1.99	1.99	2.87	8.85	(3.4 - 9.8)		
	2.2 + 2.2 + 2.2 + 3.5	= 10.1	1.71	1.71	1.71	2.72	7.85	(2.9 - 9.2)		1.91	1.91	1.91	3.21	8.95	(3.4 - 9.8)		
	2.2 + 2.2 + 2.2 + 5.15	= 11.8	1.5	1.5	1.5	3.51	8	(2.9 - 9.2)		1.71	1.71	1.71	4.11	9.25	(3.4 - 9.8)		
	2.2 + 2.2 + 2.2 + 7.1	= 13.7	1.28	1.28	1.28	4.15	8	(2.9 - 9.2)		1.47	1.47	1.47	4.99	9.4	(3.4 - 9.8)		
	2.2 + 2.2 + 2.65 + 2.65	= 9.7	1.76	1.76	2.12	2.12	7.75	(2.9 - 9.2)		1.85	1.85	2.67	2.67	9.05	(3.4 - 9.8)		
	2.2 + 2.2 + 2.65 + 3.5	= 10.6	1.66	1.66	2	2.64	7.95	(2.9 - 9.2)		1.79	1.79	2.57	3	9.15	(3.4 - 9.8)		
	2.2 + 2.2 + 2.65 + 5.15	= 12.2	1.44	1.44	1.74	3.38	8	(2.9 - 9.2)		1.61	1.61	2.32	3.86	9.4	(3.4 - 9.8)		
	2.2 + 2.2 + 2.65 + 7.1	= 14.2	1.24	1.24	1.5	4.01	8	(2.9 - 9.2)		1.37	1.37	1.98	4.67	9.4	(3.4 - 9.8)		
	2.2 + 2.2 + 3.5 + 3.5	= 11.4	1.54	1.54	2.46	2.46	8	(2.9 - 9.2)		1.72	1.72	2.88	2.88	9.2	(3.4 - 9.8)		
	2.2 + 2.2 + 3.5 + 5.15	= 13.1	1.35	1.35	2.15	3.16	8	(2.9 - 9.2)		1.55	1.55	2.6	3.71	9.4	(3.4 - 9.8)		
	2.2 + 2.2 + 5.15 + 5.15	= 14.7	1.2	1.2	2.8	2.8	8	(2.9 - 9.2)		1.38	1.38	3.32	3.32	9.4	(3.4 - 9.8)		
	2.2 + 2.65 + 2.65 + 2.65	= 10.2	1.7	2.05	2.05	2.05	7.85	(2.9 - 9.2)		1.73	2.49	2.49	2.49	9.2	(3.4 - 9.8)		
	2.2 + 2.65 + 2.65 + 3.5	= 11	1.6	1.93	1.93	2.55	8	(2.9 - 9.2)		1.67	2.41	2.41	2.81	9.3	(3.4 - 9.8)		
	2.2 + 2.65 + 2.65 + 5.15	= 12.7	1.39	1.68	1.68	3.26	8	(2.9 - 9.2)		1.5	2.16	2.16	3.59	9.4	(3.4 - 9.8)		
	2.2 + 2.65 + 3.5 + 3.5	= 11.9	1.49	1.79	2.36	2.36	8	(2.9 - 9.2)		1.62	2.33	2.72	2.72	9.4	(3.4 - 9.8)		
	2.2 + 2.65 + 3.5 + 5.15	= 13.5	1.3	1.57	2.07	3.05	8	(2.9 - 9.2)		1.44	2.08	2.42	3.46	9.4	(3.4 - 9.8)		
	2.2 + 3.5 + 3.5 + 3.5	= 12.7	1.39	2.2	2.2	2.2	8	(2.9 - 9.2)		1.56	2.61	2.61	2.61	9.4	(3.4 - 9.8)		
	2.2 + 3.5 + 3.5 + 5.15	= 14.4	1.23	1.95	1.95	2.87	8	(2.9 - 9.2)		1.39	2.34	2.34	3.34	9.4	(3.4 - 9.8)		
	2.65 + 2.65 + 2.65 + 2.65	= 10.6	2	2	2	2	8	(2.9 - 9.2)		2.35	2.35	2.35	2.35	9.4	(3.4 - 9.8)		
	2.65 + 2.65 + 2.65 + 3.5	= 11.5	1.85	1.85	1.85	2.45	8	(2.9 - 9.2)		2.26	2.26	2.26	2.63	9.4	(3.4 - 9.8)		
	2.65 + 2.65 + 2.65 + 5.15	= 13.1	1.62	1.62	1.62	3.15	8	(2.9 - 9.2)		2.01	2.01	2.01	3.36	9.4	(3.4 - 9.8)		
	2.65 + 2.65 + 3.5 + 3.5	= 12.3	1.72	1.72	2.28	2.28	8	(2.9 - 9.2)		2.17	2.17	2.53	2.53	9.4	(3.4 - 9.8)		
	2.65 + 2.65 + 3.5 + 5.15	= 14	1.52	1.52	2.01	2.95	8	(2.9 - 9.2)		1.94	1.94	2.27	3.24	9.4	(3.4 - 9.8)		
	2.65 + 3.5 + 3.5 + 3.5	= 13.2	1.61	2.13	2.13	2.13	8	(2.9 - 9.2)		2.09	2.44	2.44	2.44	9.4	(3.4 - 9.8)		
	3.5 + 3.5 + 3.5 + 3.5	= 14	2	2	2	2	8	(2.9 - 9.2)		2.35	2.35	2.35	2.35	9.4	(3.4 - 9.8)		

argoclima S.p.A.

Via Varese, 90 - 21013 Gallarate (VA) - Italy
Tel. +39 0331 755111 - Fax +39 0331 776240
<http://www.argoclima.com>
