

MODEL

C 10RA2

HITACHI
POWER TOOLS

TABLE SAW
C 10RA2

TECHNICAL DATA
AND
SERVICE MANUAL

C

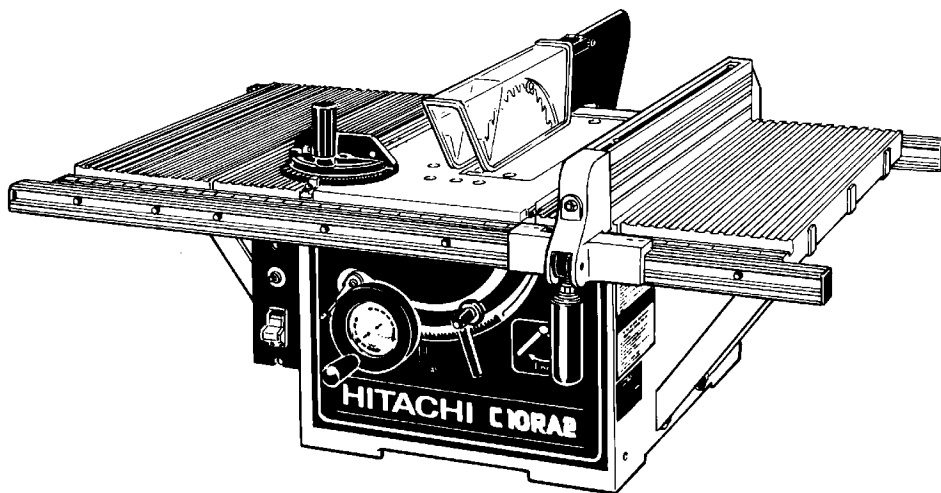

LIST No. E929

Sep. 1999

SPECIFICATIONS AND PARTS ARE SUBJECT TO CHANGE FOR IMPROVEMENT

REMARK:

Throughout this TECHNICAL DATA AND SERVICE MANUAL, a symbol(s) is(are) used in the place of company name(s) and model name(s) of our competitor(s). The symbol(s) utilized here is(are) as follows:

Symbol Utilized	Competitor	
	Company Name	Model Name
C	MAKITA	2703

CONTENTS

[Business Section]	Page
1. PRODUCT NAME	1
2. MARKETING OBJECTIVE	1
3. APPLICATIONS	1
4. SELLING POINTS	1
4-1. Selling Point Descriptions	2
5. SPECIFICATIONS	3
5-1. Specifications	3
5-2. Outside View and External Dimensions	4
6. COMPARISONS WITH SIMILAR PRODUCTS	5
7. PRECAUTIONS IN SALES PROMOTION	6
7-1. Instruction Manual	6
7-2. Precautions on the Name Plate	6
7-3. Warning Label (A)	6
7-4. Warning Label (B)	7
7-5. Package	8
7-6. Packing	8
7-7. Related Laws and Regulations	8
8. PRECAUTIONS ON OPERATION	9
8-1. Unpacking	9
8-2. Assembly	10
8-3. Adjustment	12
8-4. Relation between Saw Blade and Spreader	16
8-5. Overload Protective Device	16
8-6. Precautions on Using the Electric Brake	16
8-7. Extension Cords	17
8-8. Cutting Work	18
9. MAINTENANCE AND INSPECTION	19
9-1. Inspecting the Saw Blade	19
9-2. Inspecting the Carbon Brushes	19
9-3. Inspecting the Mounting Screws	19
9-4. Inspecting the Saw Blade Guard for Proper Operation	20
9-5. Regular Cleaning of the Saw Blade Guard	20
9-6. Storage	20
9-7. Lubrication	20
9-8. Cleaning	20

[Service Section]

10. PRECAUTIONS IN DISASSEMBLY AND REASSEMBLY 21

 10-1. Disassembly 21

 10-2. Reassembly 28

 10-3. Wiring 29

 10-4. Adjustments 30

 10-5. Product Precision 30

11. REPAIR GUIDE 31

12. STANDARD REPAIR TIME (UNIT) SCHEDULES 34

[Appendix]

Assembly Diagram for C 10RA2 35

1. PRODUCT NAME

Hitachi Table Saw, Model C 10RA2

2. MARKETING OBJECTIVE

The Model C 10RA2 was developed to upgrade and replace the current Model C 10RA.

The key features of the Model C 10RA2 are as follows:

- (1) Smooth-sliding fence mounted on rails at the front and the rear of the table
- (2) One-touch fence setting, thanks to a quick lock fence system
- (3) More stable guide of a workpiece with the 3-inch-height fence (C 10RA: 2-inch height)

The basic structure of the product is the same as that of the Model C 10RA.

3. APPLICATIONS

Rip-sawing and cross-cutting of ordinary wood, hardwood, plywood, composite wood materials, plastics and similar materials.

4. SELLING POINTS

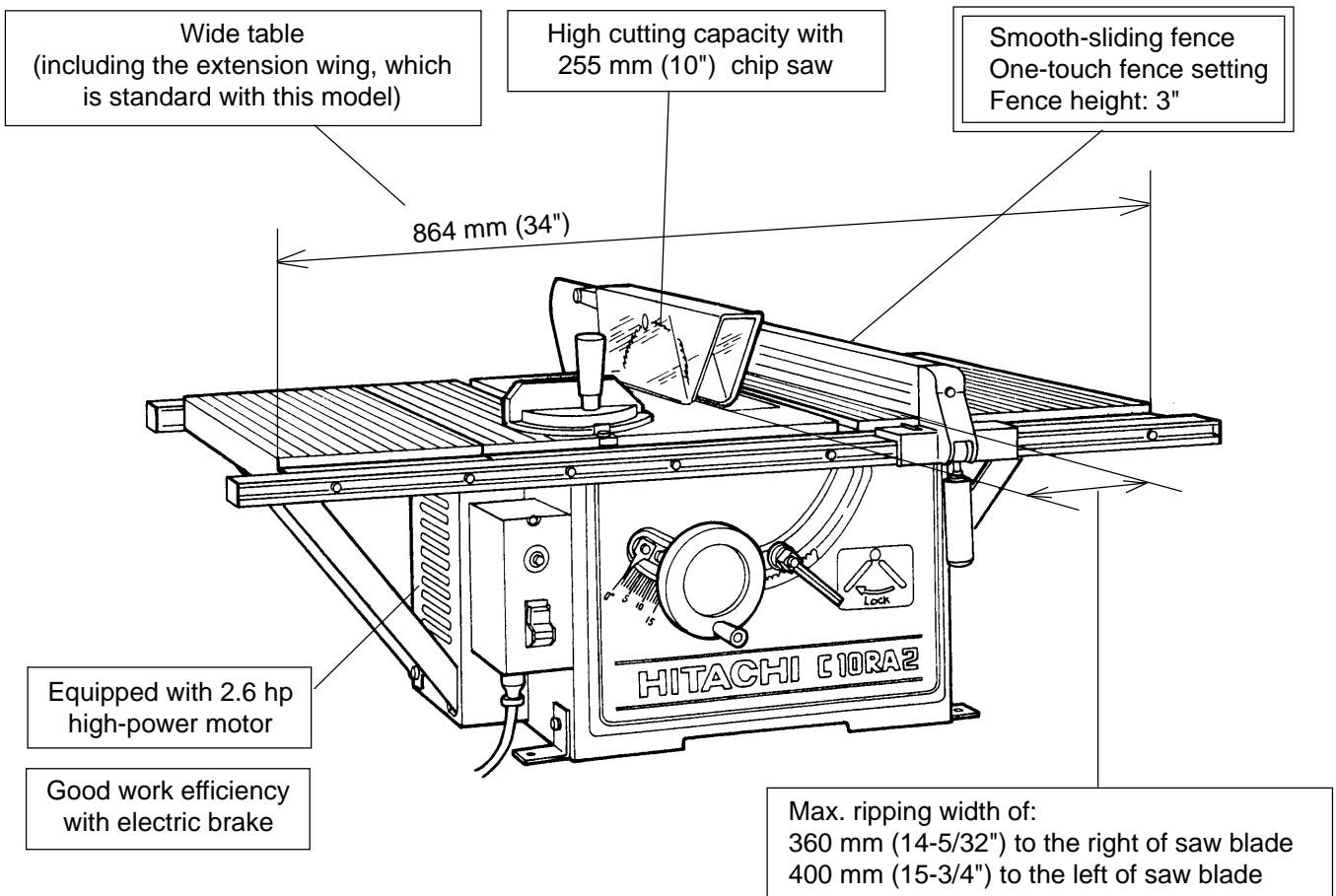

4-1. Selling Point Descriptions

(1) Wide table

An extension wing is standard on this machine to give the table a width of 864 mm (34"). This provides a wide ripping surface of up to 360 mm (14-5/32") to the right of the saw blade and up to 400 mm (15-3/4") to the left of the saw blade when using the rip fence.

Table 1

(Unit: mm)

Maker/ Model name	Max. ripping width	
	To right of saw blade	To left of saw blade
HITACHI C 10RA2	360 (14-5/32")	400 (15-3/4")

(2) High cutting capacity with 255 mm (10") TCT blade

A 255 mm (10") TCT saw blade is standard on this machine.

Table 2

(Unit: mm)

Maker/ Model name	Cutting depth of saw blade		Cut section
	90°	45° Bevel	Max. surface roughness
HITACHI C 10RA2	0 – 76 (0 – 3")	11 – 63 (7/16" – 2-1/2")	44 μm

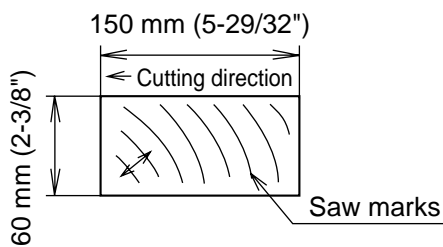

Fig. 1

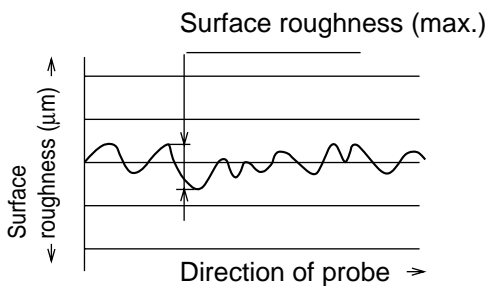

Fig. 2

Cutting material: Douglas fir

Percentage of water content: 13 to 16 %

Right-angle cutting in 17 seconds.

Using the roughness meter, the roughness (irregularities in the surface shown in Fig. 2) was measured by moving the probe in the direction of the arrow as shown in Fig. 1.

(3) Good work efficiency with electric brake

When the switch is turned off after a cutting operation, the electric brake will stop the saw blade (in about 3 – 5 seconds). Efficient operation is assured when removing the cut material.

Table 3

(Unit: W)

(4) Equipped with a high-power 1,940 W (2.6 hp) motor

The high-power motor facilitates fast cutting operations.

Hitachi C 10RA2 60 x 150 mm material 15 seconds

Maker/Model name	Max. output
HITACHI C 10RA2	1,940 (2.6 hp)

5. SPECIFICATIONS

5-1. Specifications

Item		Specifications		
Max. cutting depth	Saw blade	Cutting angle	90°	45° bevel
		Outer diameter 255 mm (10")	0 – 76 mm (0 – 3")	11 – 63 mm (7/16" – 2-1/2")
Saw blade dimensions (supplied TCT blade)		Outer dia. 255 mm (10") x Inner dia. 15.9 mm (5/8") x Teeth number 36		
Table	Table surface dimensions			
	Table surface height	310 mm (12-3/16") 905 mm (35-5/8") (when mounted on the optional table saw stand)		
Power source	Table voltage	AC single phase 60 Hz, 115 V		
Motor	Type Rated current Input	AC single phase commutator motor, 15 A, 1,640 W		
	No-load speed	5,000 /min		
Weight		Net: 29 kg (64 lbs) Gross: 38 kg (84 lbs) Net (with table saw stand): 38 kg (84 lbs) Gross: 46 kg (101 lbs)		
Packaging		Corrugated cardboard box		
Cord		Three-core cabtire cable, 2.0 mm ² (14 A.W.G.) x 2 m (6.5 ft.)		
Standard equipment		255 mm (10") TCT saw blade (36 teeth) 1 Set plate 4 Wrench (22 mm) 1 Wrench (23 x 26 mm) 1 Elbow (chip extraction duct) 1		
Optional accessories		Dado insert (for dado cutter) (Code No. 314325) Push stick (Code No. 314324) Table saw stand (Code No. 314819)		

5-2. Outside View and External Dimensions

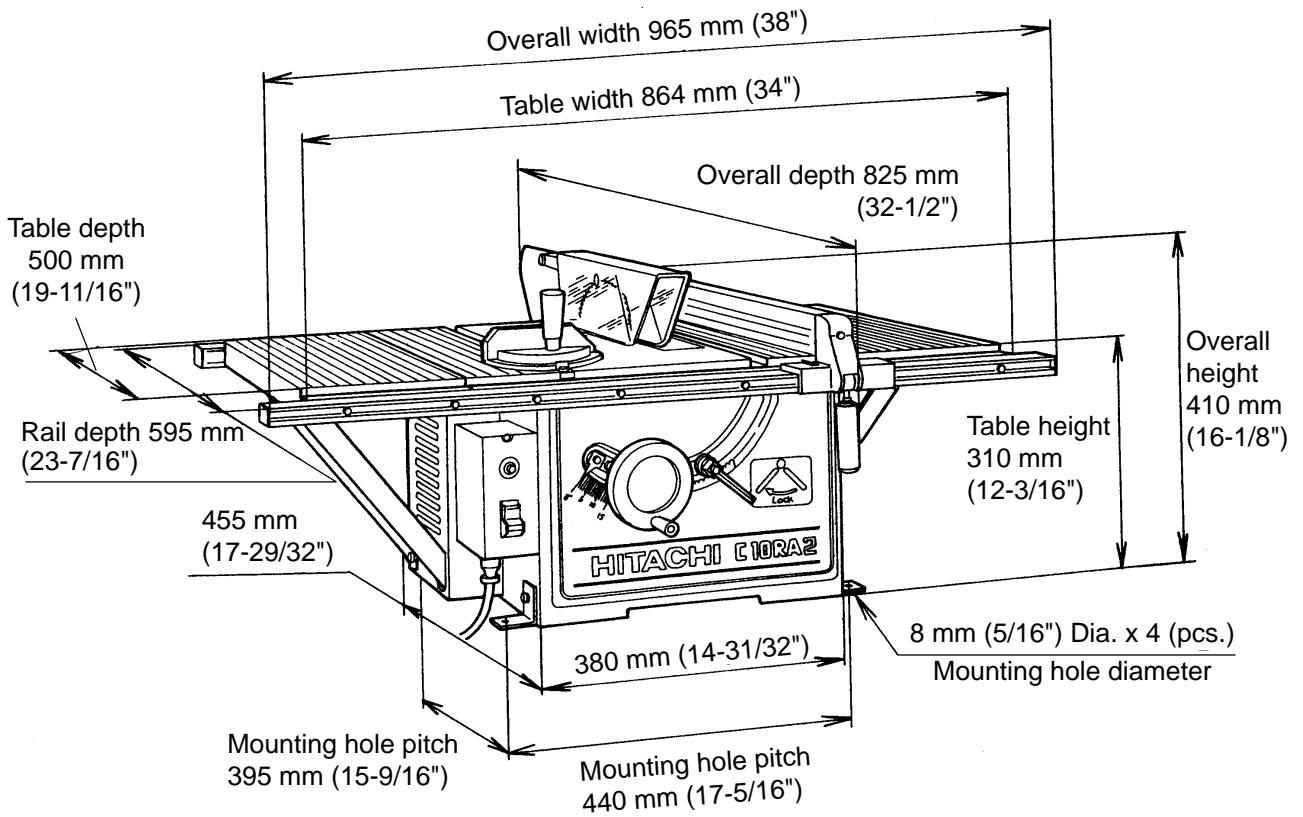

Fig. 3

6. COMPARISONS WITH SIMILAR PRODUCTS

Item		Maker Model	HITACHI C 10RA2/C 10RA	C
Saw blade	Outer diameter		255 mm (10")	255 mm (10")
	Inner diameter		15.8 mm (5/8")	15.8 mm (5/8")
Maximum cutting	0° (right angle)		76 mm (3")	91 mm (3-9/16")
	45° (bevel)		11 mm – 63 mm (7/16" – 2-1/2")	63 mm (2-1/2")
Maximum dado cutter size (diameter x width)			152 mm x 12 mm (6" x 1/2")	—
Maximum ripping capacity			Right side 360 mm (14-5/32") Left side 400 mm (15-3/4")	Right side 305 mm (12") Left side 305 mm (12")
Table dimensions (width x depth)			494 mm x 500 mm (19-7/16" x 19-11/16")	680 mm x 560 mm (27" x 22")
Table dimensions with extensions (width x depth)			864 mm x 500 mm (34" x 19-11/16")	—
Motor	Voltage, Current		115 V, 15 A	115 V, 15 A
	Rated input		1,640 W	—
	Max. output		1,940 W (2.6 hp)	—
	No-load speed		5,000 /min	4,600 /min
Electric brake			Provided	Provided
Dust collection port			O.D. 65 mm x I.D. 59 mm (O.D. 9/16" x I.D. 5/16")	—
Machine dimensions (width x depth x height)			[C 10RA2] 965 mm x 825 mm x 410 mm (38" x 32-1/2" x 16-1/8") [C 10RA] 864 mm x 750 mm x 410 mm (34" x 29-17/32" x 16-1/8")	686 mm x 560 mm x 458 mm (27" x 22" x 18")
Net weight			[C 10RA2] Net: 29 kg (64 lbs) Gross: 38 kg (84 lbs) Net (with table saw stand): 38 kg (84 lbs) Gross: 46 kg (101 lbs) [C 10RA] Net (with extension wing): 25.4 kg (56 lbs) Gross: 29 kg (64 lbs)	18 kg (40 lbs)
Standard equipment			255 mm (10") TCT saw blade (NT 36) 1 Set plate 4 Wrench (22 mm) 1 Wrench (23 mm x 26 mm) 1 Elbow (chip extraction duct) 1	255 mm (10") TCT saw blade 1 Rip fence 1 Miter gauge 1 Wrench (19 mm) 1 Wrench (13 mm x 22 mm) 1
Optional accessories			Table saw stand (Code No. 314819) Push stick (Code No. 314324) Dado insert (Code No. 314325)	Table saw stand Porta table Rip fence Miter gauge Dado head set Ring (for use with dado head set)

7. PRECAUTIONS IN SALES PROMOTION

In the interest of promoting the safest and most efficient use of the Model C 10RA2 Table Saw by all of our customers, it is very important that at the time of sale, the salesperson carefully ensures that the buyer seriously recognizes the importance of the contents of the Instruction Manual, and fully understands the meaning of the precautions listed on the various caution plates attached to each machine.

7-1. Instruction Manual

Although every effort is made in each step of design, manufacture and inspection to provide protection against safety hazards, the dangers inherent in the use of any electric tool cannot be completely eliminated. Accordingly, general precautions and suggestions for the use of electric power tools, and specific precautions and suggestions for the use of the table saw are listed in the Instruction Manual to enhance the safe and efficient use of the tool by the customer. Salespersons must be thoroughly familiar with the contents of the Instruction Manual to be able to offer appropriate guidance to the customer during sales promotion.

7-2. Precautions on the Name Plate

Each Model C 10RA2 is furnished with a Name Plate that lists the following precautions:

CAUTION <ul style="list-style-type: none">• For Safe operation, see Instruction Manual.• Always wear eye protection.• Do not use saw blade rated below 6000 rpm.• Use guards with saw blade.①②③④
--	--------------------------------------

- (1) Instruct the customer to read the Instruction Manual thoroughly prior to attempting to operate the machine.
- (2) As cutting chips or sawdust flying into the eyes of the operator could result in loss of sight, it is absolutely necessary to caution the customer to wear protective glasses whenever operating the machine.
- (3) Instruct the customer never to use a saw blade with a rated maximum rotation speed of less than 6,000 /min. If a saw blade with a rated maximum rotation speed of less than 6,000 /min is used, there is a danger that one or more of the blade tips could fly off unexpectedly and cause serious injury to the operator or anyone else in the immediate area.
- (4) Instruct the customer to confirm without fail that all saw blade guards and other safety devices furnished with the machine are properly mounted before attempting to operate the machine.

7-3. Warning Label (A)

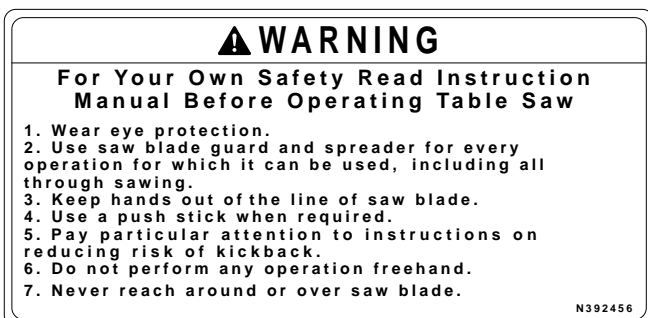

This is mounted on the right side of the body shell. Please instruct users to strictly observe the contents of 1 to 7 in the warning label shown at left. (Warning Label (A) is not provided on some areas' models.)

- (1) Be sure to wear the protective glasses.
- (2) Advise the user to use the saw blade guard and spreader when using the table saw. The saw blade guard prevents the operator from touching the saw blade and the dislodging of workpieces. This should be employed to ensure safety.
- (3) Take care to keep the hands away from the saw blade.
- (4) Explain the procedure for making and using the push stick (optional accessory) to the user. Details are contained in the Instruction Manual (refer to page 17, 8. Work Helpers). Advise the user to use the push stick when cutting a narrow workpiece vertically.
- (5) If the workpiece dislodges, it may injure the operator.
Follow the dislodging preventive measures in the Instruction Manual. Advise the user to check that the dislodging preventive claw (anti-kickback pawls) works correctly and the claw (anti-kickback pawls) edge is sharp enough to bite into the workpiece before starting operation.
- (6) Use both hands during cutting work. For cross cutting, hold the workpiece and miter gauge securely. For vertical cutting, hold the workpiece and press it onto the rip fence surface securely by hand. These precautions are fundamental to cutting work.
- (7) Never get too close to the saw blade and be especially careful about the exposed rotating teeth.

7-4. Warning Label (B)

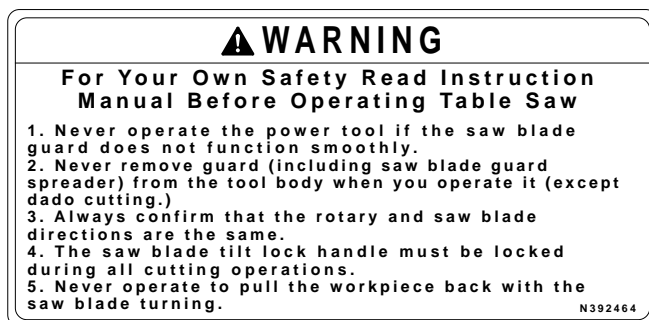

This is mounted on the right side of the body shell. Please instruct users to strictly observe the contents of 1 to 5 in the warning label shown at left.

- (1) The saw blade guard is designed to protect the operator from coming into contact with the saw blade during operation of the tool.
- (2) The saw blade guard and spreader are for safe operation. Do not operate the machine without the saw blade guard and spreader (except for dado cutting).
- (3) When mounting the saw blade, check that the saw blade's direction of rotation matches the machine's direction of rotation.
- (4) Be sure to lock the tilt lock handle to prevent tilting of the saw blade during operation.
- (5) If the wood is pulled toward the operator during cutting, it may be repelled by the saw blade (kickback). Never pull the wood toward the operator during cutting.

7-5. Package

The table saw Model C 10RA2 is divided into the main body and the saw blade guard sections before packing and shipping. Therefore, buyers of this machine are required to perform some light assembly. Instruct customers to carefully read the assembly procedure in the Instruction Manual.

Dimensions of cardboard box (mm)

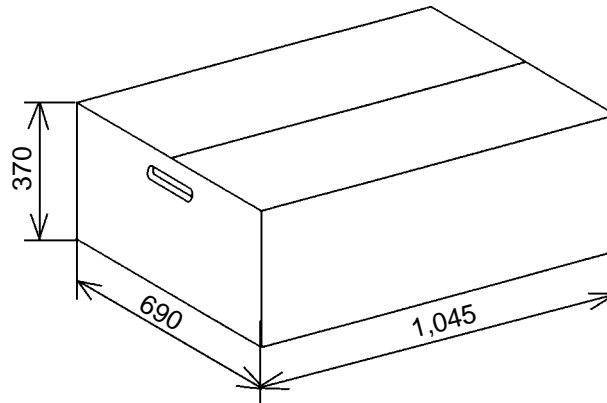

Fig. 4

7-6 Packing

- (1) Remove the saw blade guard, rip fence and the miter gauge from the main body.
- (2) Set the saw blade to the lower limit position.
- (3) Disassemble the table saw stand.
- (4) Pack the saw blade guard, rip fence and table saw stand separately in each carton box. Pack the miter gauge in the carton box which is to be housed in the body shell of the main body.
- (5) Put the main body in the carton box.
- (6) Put packing (A) and (B).
- (7) Close the lids of the carton box and bind them together.

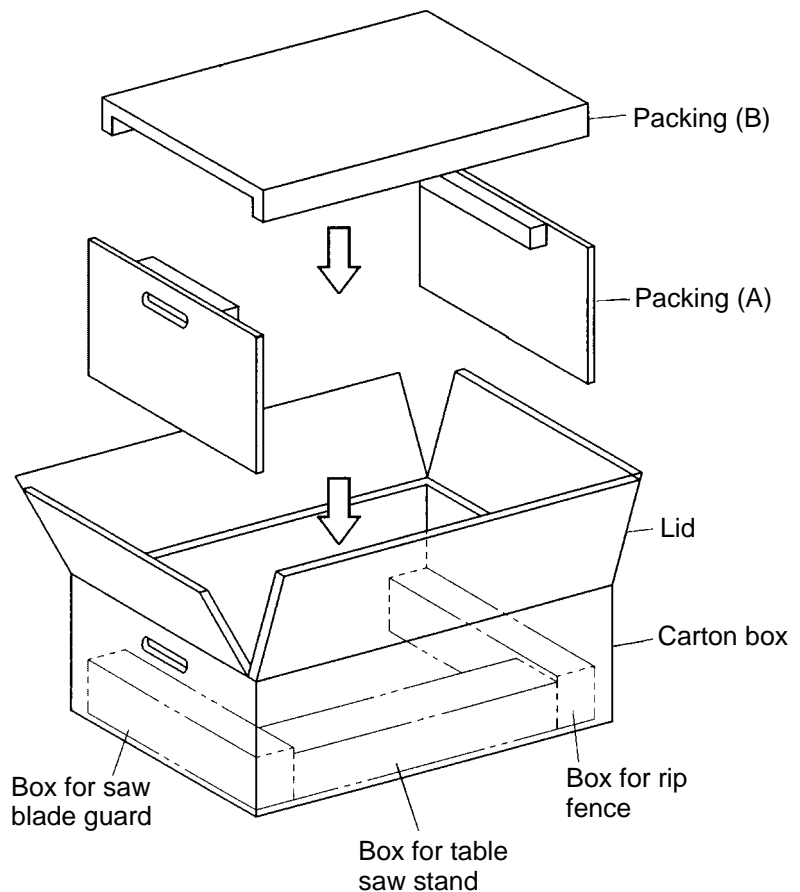

Fig. 5

7-7. Related Laws and Regulations

The Model C 10RA2 has passed the C-UL standard. Therefore, the operator's safety is assured if it is operated according to the Instruction Manual. The most important thing is to familiarize the user with the machine, so advise the user on correct operation and thus ensure the user's safety.

Misoperation will cause a serious accident. Please be very careful in advising the user.

8. PRECAUTIONS ON OPERATION

8-1. Unpacking

The parts illustrated in Fig. 6 are packaged together with the tool.

When unpacking, carefully confirm that all parts are accounted for.

Refer to the instructions packed in the carton box for the components of the table saw stand.

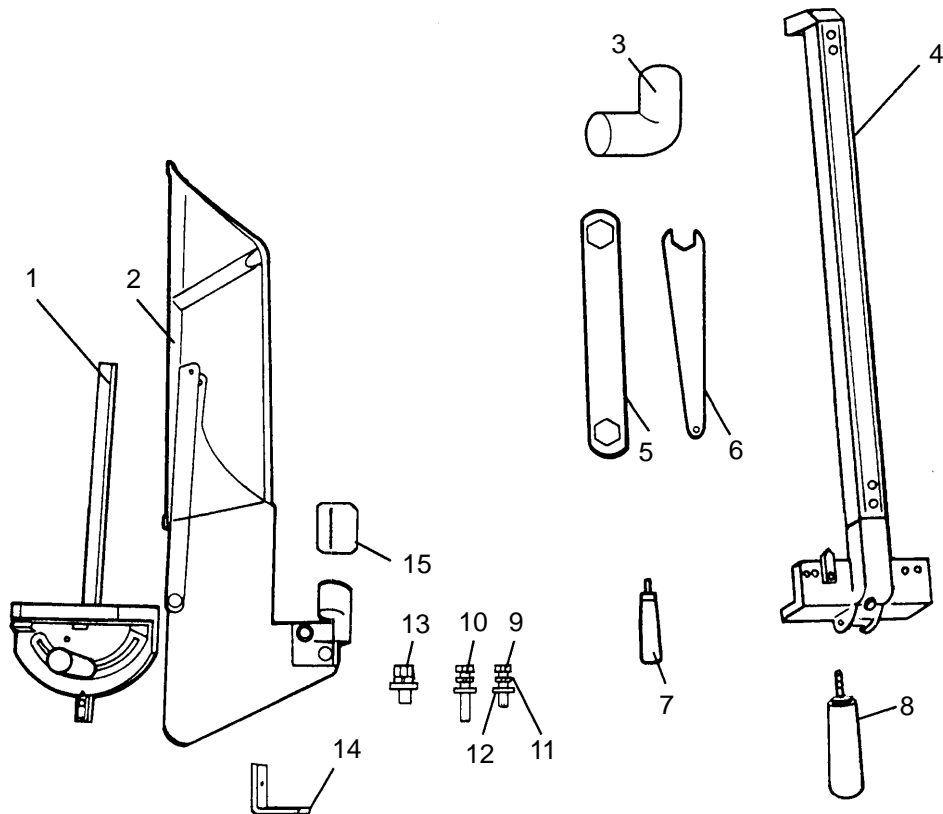

Fig. 6

- | | |
|--|--|
| 1. Miter gauge (1 piece) | 8. Grip (1 piece) |
| 2. Saw blade guard and spreader assembly (1 piece) | 9. 6 x 90 mm Bolt (1 piece) |
| 3. Elbow (1 piece) | 10. 6 x 110 mm Bolt (1 piece) |
| 4. Rip fence (1 piece) | 11. 6 mm Spring washer (2 pieces) |
| 5. Hex. wrench (1 piece) | 12. 6 mm Flat washer (2 pieces) |
| 6. Wrench (1 piece) | 13. 8 x 20 mm Bolt (with/washers) (4 pieces) |
| 7. Handle bar (1 piece) | 14. Set plate (4 pieces) |
| | 15. Cushion (1 piece) |

8-2. Assembly

⚠WARNING: To avoid an accident or personal injury, always confirm that the switch is turned OFF and the power plug has been disconnected from the receptacle before assembly of this tool.

8-2-1. Assembly of the Handle Bar

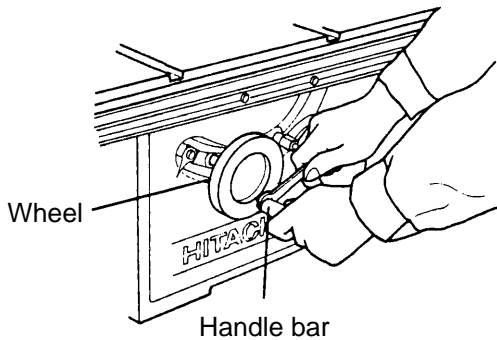

Fig. 7

The handle allows faster turning of the wheel.

When properly assembled, it will rotate freely but with only a small amount of play,

- (1) Tighten the screw of the handle until it hits against the wheel.
- (2) Securely tighten the handle bar nut with a wrench.

8-2-2. Installing of the Rip Fence

⚠CAUTION: The rip fence must be aligned parallel to the saw blade to minimize kickback.

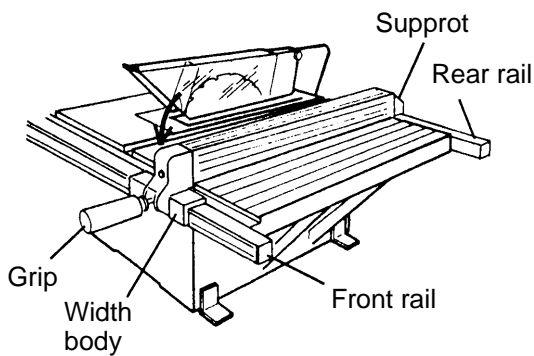

Fig. 8

The rip fence can be conveniently used to cut a workpiece into different pieces of precise width or into parallel pieces.

It can be mounted on either the right or left side of the table.

- (1) Tighten the screw of the grip.
- (2) Catch the hook of the support in the bottom part of the rear rail.
- (3) Lower the rip fence in the arrow direction, and fit the part of the width body and support to the groove of the front and rear rail.
- (4) Confirm that the rip fence is moved right and left and it moves smoothly.

8-2-3. Assembly of the Miter Gauge

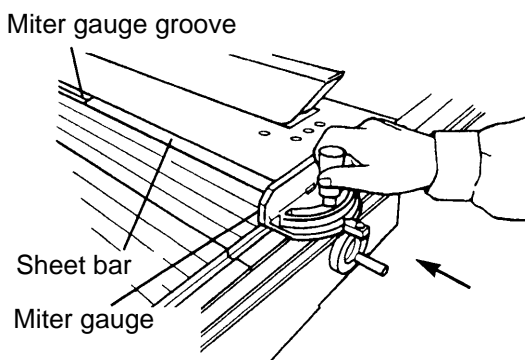

Fig. 9

The miter gauge is convenient for cutting long or angular pieces which are difficult to work on with the rip fence. It can be mounted on either the right or left side of the table.

Align the sheet bar of miter gauge with the miter gauge groove and slide it in the direction indicated by the arrow through the front of the table.

8-2-4. Mounting and Adjusting the Saw Blade Guard Assembly

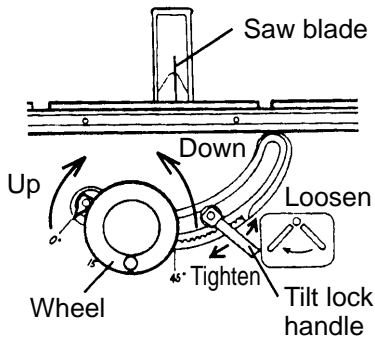

Fig. 10-a

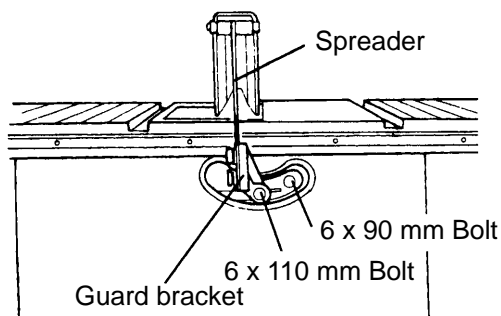

Fig. 10-b

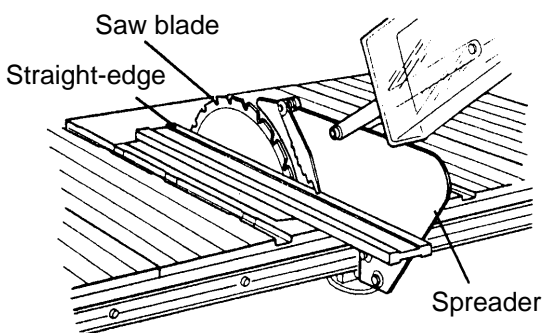

Fig. 10-c

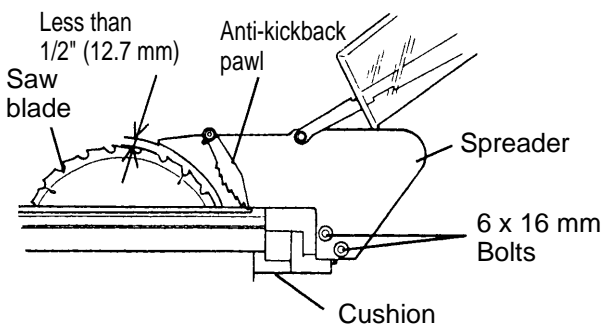

Fig. 10-d

⚠CAUTION: The saw blade guard and spreader assembly must be aligned properly to the saw blade in order to prevent kickback.

Mount the saw blade guard assembly, which includes the spreader and anti-kickback pawls (see Fig. 10-d).

(1) Mounting the spreader

- ① Loosen the saw blade tilt lock handle, move the saw blade tilting mechanism to the left and set the saw blade to 0° by means of the stopper. Tighten the saw blade tilt lock handle to lock it in position.
- ② Turn the wheel fully clockwise and set the saw blade to the maximum cutting height (see Fig. 10-a).
- ③ Put a 6 mm spring washer and a D13 flat washer on to the 6 x 90 mm and 6 x 110 mm bolts.
- ④ Tentatively fasten the spreader on the rear section of the body using the cushion and two 6 mm bolts mentioned above (see Fig. 10-b and Fig. 10-d). (The guard bracket must be attached to the spreader in advance.)

(2) Adjusting the spreader

- ① Use a straight-edge to align the spreader with the saw blade (see Fig. 10-c). Tighten the two 6 x 16 mm bolts (see Fig. 10-d) with a wrench to lock the spreader.
- ② Check clearance between saw blade tip and the spreader. It should be less than 1/2" (12.7 mm) at all positions. If not, loosen the two 6 x 16 mm bolts securing the spreader to the guard bracket with a wrench and move the spreader up and down. After adjustment of the spreader is complete, firmly retighten the two 6 x 16 mm bolts with a wrench (see Fig. 10-d).

8-2-5. Mounting the Table Insert

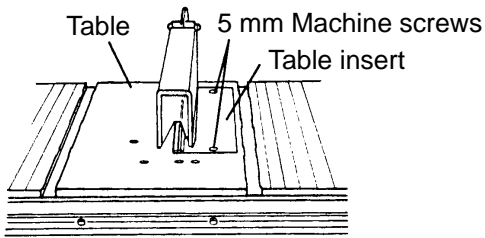

Fig. 11

The table insert is mounted to the table with two 5 mm machine screws.

⚠CAUTION: The table insert must be in place and securely fastened at all times.

8-2-6. Mounting the Elbow (Chip Extraction Duct) (Standard Accessory)

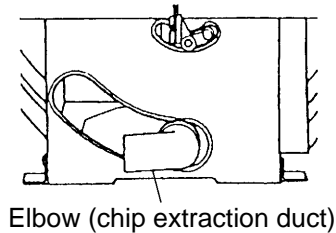

Fig. 12

Connect a 65 mm (2-9/16") hose from a dust collector to the chip extraction duct to suck cutting chips away. Mount the chip extraction duct on the chip discharge outlet at the rear of the body.

8-3. Adjustment

The tool is accurately adjusted before shipping from the factory.

Check the following settings and readjust them if necessary in order to obtain the best results in operation.

⚠WARNING: To avoid an accident or personal injury, always confirm that the switch is turned OFF and the power plug has been disconnected from the receptacle before adjustment of this tool.

8-3-1. Adjustment of Saw Blade parallel to Miter Gauge Groove

This is probably the most difficult of the adjustments. Before shipment from the factory this adjustment was made but it should be rechecked and readjusted if necessary.

⚠CAUTION: The adjustment must be correct or kickback could result and accurate cuts could not be made.

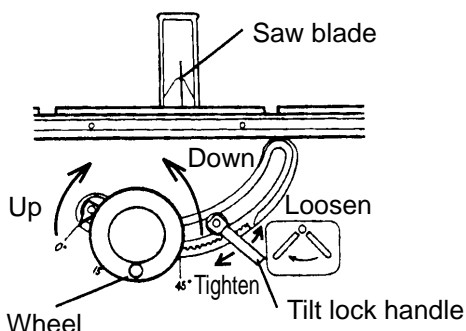

Fig. 13-a

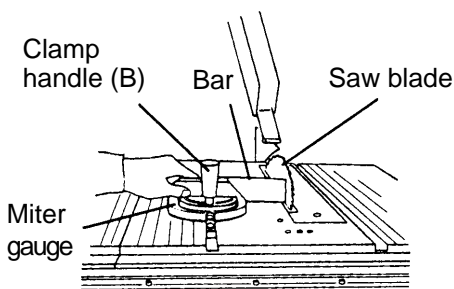

Fig. 13-b

- (1) Loosen the saw blade tilt lock handle by turning it counterclockwise. Move the saw blade tilting mechanism to the left and set the saw blade to 0° with the stopper.
- (2) Turn the wheel fully clockwise and set the saw blade to the maximum cutting height (see Fig. 13-a).
- (3) Select a tooth on the saw blade which is bent to the right.
- (4) Mark that tooth with a pencil or permanent marker.
- (5) Set the miter gauge to 90° and tighten the clamp handle (B) to lock it in that position. Place the miter gauge in the left hand miter gauge groove in the table top (see Fig. 13-b).
- (6) Rotate the saw blade to bring the marked tooth to the front and about 12.7 mm (1/2") above the table top.
- (7) Place a bar or square flat against the miter gauge.
- (8) Move the bar or square toward the saw blade until it just touches the tip of the marked saw blade tooth.

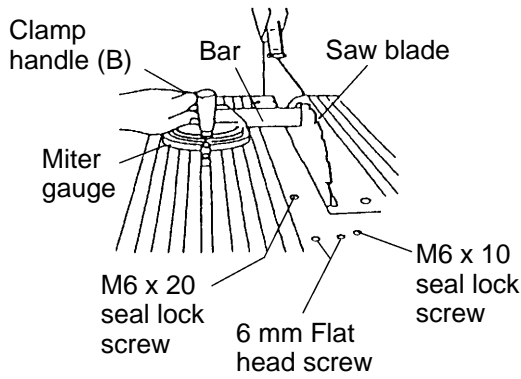

Fig. 13-c

- (9) Without disturbing the bar clamped to the miter gauge, move the miter gauge to the center of the saw blade.
- (10) Rotate the marked tooth to the rear and slide the miter gauge rearward until the clamped bar is closest to the tip of the marked saw blade tooth (see Fig. 13-c).
- (11) If the bar just touched the tooth when the gauge was in the front position, it should just touch the tooth in the rear position.
Likewise, if there was some clearance between the bar and the tooth tip at the front, the same clearance should be at the rear.
- (12) If the front and rear clearance are not identical,
 - ① Remove the miter gauge.
 - ② Loosen the four 6 mm flat head screws.
 - ③ Move the body and adjust it so that a bar placed on the miter gauge has the same clearance between the front and the rear of the saw blade.
 - ④ Tighten the four 6 mm flat head screws.

8-3-2. Adjusting the 90° and 45° Positive Stops

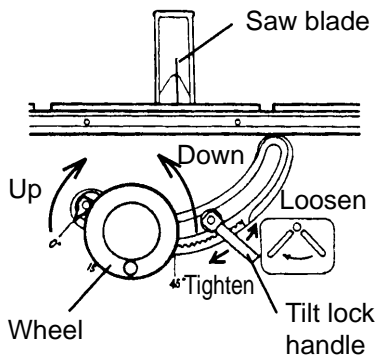

Fig. 14-a

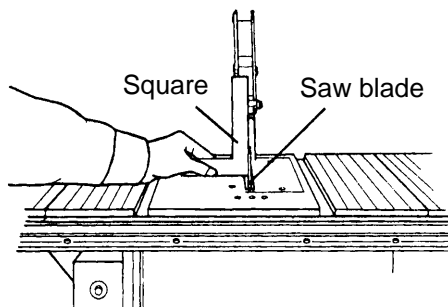

Fig. 14-b

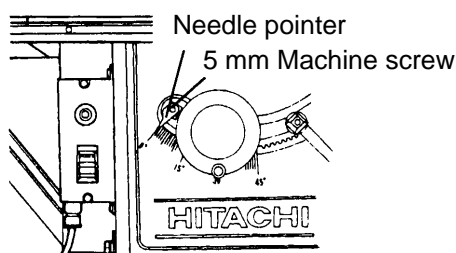

Fig. 14-c

The tool is equipped with positive stops for rapid and accurate positioning of the saw blade at 90° and left bevel 45° to the table.

Check and adjust the positive stops with the following procedures.

- (1) To adjust positive stop at 90°
 - ① Turn the wheel fully clockwise and set the saw blade to the maximum cutting height.
 - ② Loosen the saw blade tilt lock handle and move the saw blade tilting mechanism to the left until it hits against the stopper. Then tighten the saw blade tilt lock handle (see Fig. 14-a).
 - ③ Use a square to check that the saw blade is at precisely 90° (see Fig. 14-b).
 - ④ If the saw blade is not at precisely 90°, loosen the saw blade tilt lock handle by turning it counterclockwise. Loosen the M6 x 20 seal lock screw (see Fig. 13-c) a few turns and move the saw blade tilting mechanism until the blade is 90° to the table (see Fig. 14-b).
 - ⑤ Tighten the saw blade tilt lock handle after adjustment.
 - ⑥ Loosen the 5 mm machine screw and set the needle pointer to 0°. On completion of adjustment, recheck the 90° angle of the saw blade and table (see Fig. 14-c).

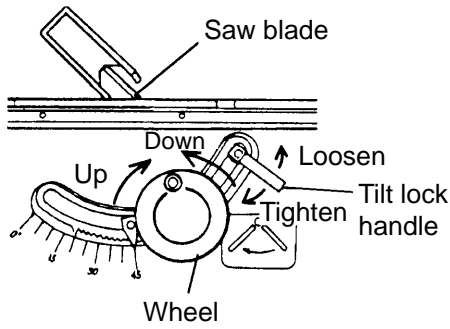

Fig. 15-a

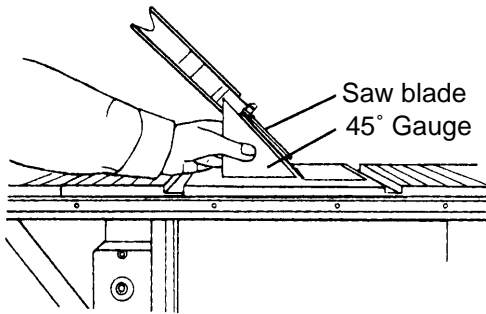

Fig. 15-b

(2) To adjust the positive stop at left bevel 45°

- ① Turn the wheel fully clockwise and set the saw blade to the maximum cutting height.
- ② Loosen the saw blade tilt lock handle and move the saw blade tilting mechanism to the right until it hits against the stopper. Then tighten the saw blade tilt lock handle (see Fig. 15-a).
- ③ Use a 45° gauge to check that the saw blade is at a left bevel 45° (see Fig. 15-b).
- ④ If the saw blade is not at a left bevel 45°, loosen the saw blade tilt lock handle. Loosen the M6 x 20 seal lock screw (see Fig. 13-c) a few turns and move the saw blade tilting mechanism until the blade is at left bevel 45° to the table (see Fig. 15-b).
- ⑤ After adjustment, tighten the saw blade tilt lock handle.
- ⑥ On completion of adjustment, recheck the left 45° bevel of the saw blade to the table.

8-3-3. Adjustment of the Rip Fence

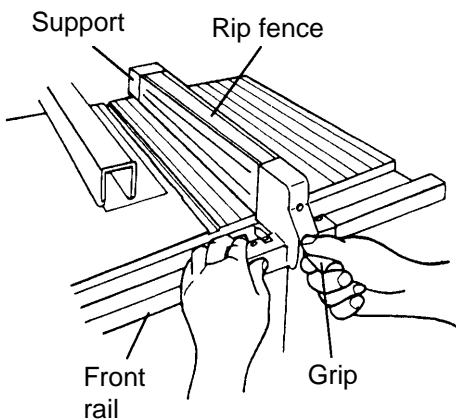

Fig. 16-a

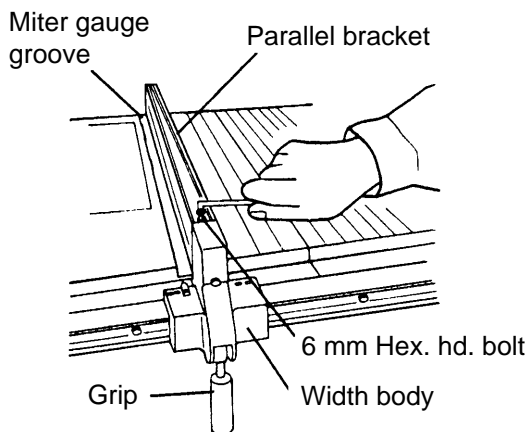

Fig. 16-b

Before shipment from the factory the saw blade is set parallel to the miter gauge groove and the rip fence is adjusted parallel to the miter gauge groove. Check and adjust the parallel of the rip fence by the following procedures. In order to accurate work and prevent kickback when ripping. Before adjustment of rip fence, check and adjust slider (It is assembled under the width body.) to engage with the groove on front rail.

- (1) Raise the grip to the upside and release the fixation of the rip fence (see Fig. 16-a).
- (2) Position the rip fence at one edge of the miter gauge groove.
- (3) Lower the grip to the bottom and fix the rip fence. The edge of the rip fence should line up parallel with the miter gauge groove.
- (4) If the edge of the rip fence is not parallel with the miter gauge groove.
 - ① Loosen the four 6 mm hex. hd. bolts securing the parallel bracket to the width body and support.
 - ② Raise the grip to the upside and release the fixation of the rip fence. Align the rip fence parallel to the miter gauge groove. Lower the grip to the bottom and fix the rip fence.
 - ③ While holding the parallel bracket to prevent movement, tighten the four 6 mm hex. hd. bolts previously loosened (see Fig. 16-b).

- ④ Raise the grip to the upside and release the fixation of the rip fence. Move and return the parallel bracket adjacent to the miter gauge groove. Lower the grip to the bottom and fix the rip fence. And verify that the parallel bracket is parallel to the miter gauge groove.
- ⑤ Repeat adjustment until it is parallel.
- ⑥ After adjustment, tighten four 6 mm hex. hd. bolts.
- ⑦ On completion of adjustment, recheck the rip fence is parallel with the miter gauge groove.

8-3-4. Adjustment of the Pointer

The pointer indicates the distance the rip fence is positioned away from the saw blade. The pointer should indicate the accurate distance from the saw blade. Check and adjust the pointer with the following procedures.

NOTE: The pointer will need to be readjusted whenever a different thickness saw blade is installed.

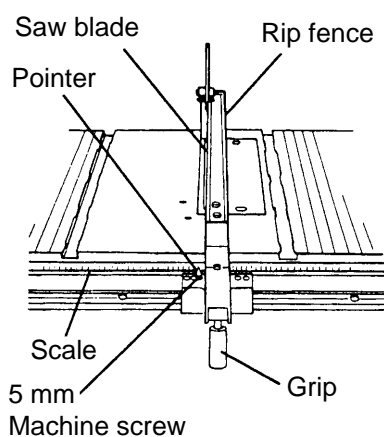

Fig. 17

To adjust the pointer 0 setting.

- (1) Raise the grip to the upside and release the lock on the rip fence. And move the rip fence to bring it into tight contact with the side of the saw blade.
- (2) Make sure that the pointer points to 0 on the scale provided on the table.
- (3) If the pointer does not point to 0 on the scale,
 - ① Lower the grip to the bottom and lock the rip fence.
 - ② Loosen the 5 mm machine screw holding the pointer (see Fig. 17).
 - ③ Adjust the pointer to the 0 position and retighten the 5 mm machine screw.
 - ④ After adjustment, recheck to see that the pointer now points to 0.

8-3-5. Adjustment of the Miter Gauge

The miter gauge should be square to the saw blade.

Check and adjust the miter gauge with the following procedures.

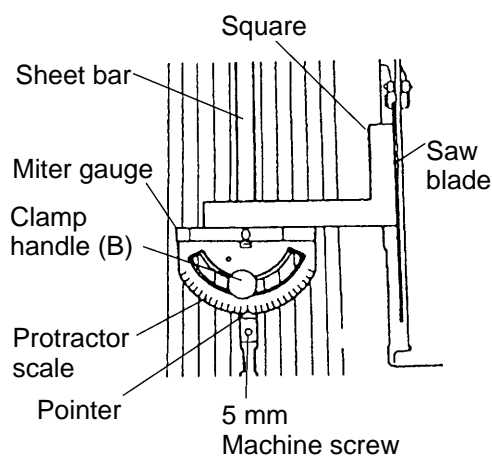

Fig. 18

To adjust the pointer 0 setting.

- (1) Loosen clamp handle (B) and place a square against both the saw blade and the miter gauge. The pointer should indicate 90° on the protractor scale on the miter gauge.
- (2) If the pointer does not indicate 0 on the miter gauge,
 - ① Tighten clamp handle (B).
 - ② Loosen the 5 mm machine screw on the sheet bar.
 - ③ Adjust the pointer to the 90° position and tighten the 5 mm machine screw on the sheet bar (see Fig. 18).
 - ④ After adjustment, recheck to see that the pointer now indicates 0.

8-4. Relation between Saw Blade and Spreader

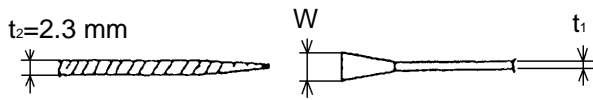

Fig. 19

The saw thickness (t_1), set width (tip width, W) and spreader thickness (t_2) are set in the following relation to prevent dislodging : $W > t_2 > t_1$.
The spreader thickness of C 10RA2 is 2.3 mm. (Fig. 19)

The spreader bites into the workpiece kerf like a wedge to prevent the saw blade from being pressed by the workpiece. Therefore, the spreader thickness needs to be larger than the saw thickness (t_1).

However, if the spreader thickness is larger than the set width (W), a large resistance is applied to the feeding of the workpiece, making operation impossible.

If a locally available saw blade is used, the above relation cannot be obtained, causing a defect in operation.

Therefore, it is important to advise the user to use only genuine Hitachi saw blades.

8-5. Overload Protective Device

This tool is provided with an overload protective device (thermal relay). If the workpiece feed speed is too fast or the saw blade is dull, the overload protective device engages to stop power to the motor and protect it. In this case, allow the motor to cool from 3 to 5 minutes and then press the reset switch to resume operation.

8-6. Precautions on Using the Electric Brake

This machine is equipped with a electric brake to stop the blade's rotation when the switch is turned OFF. When the switch is turned OFF, the rotation usually stops in 3 to 5 seconds. Should it take more than 15 seconds before stopping, the machine should not be used. Instruct the customer to contact a Hitachi electric tool dealer for inspection or repair if this occurs.

- (1) Be sure to use carbon brushes designated for this machine (Code No. 999044). The use of any other carbon brush will hinder performance of the electric brake.
- (2) Should the electric brake fail to function, check the carbon brushes. If they wear below 5 mm (3/16") in length, replace them. If the electric brake still does not function, it may be necessary to replace the armature ass'y, etc.

8-7. Extension Cords

The Instruction Manual contains a table of cord lengths and lead wire diameters. Select an appropriate extension cord. If the lead wire diameter is too small compared with the cord length, it may cause considerable voltage drop, resulting in lowered efficiency.

Use only three-wire extension cords which have three-prong grounding-type plugs and three-pole receptacles which accept the saw's plug. Replace or repair a damaged or worn cord immediately.

Make sure your extension cord is in good condition. When using an extension cord, be sure to use one heavy enough to carry the current your product will draw. An undersized cord will cause a drop in line voltage resulting in loss of power and overheating. Table 4 shows the correct size to use depending on cord length and Name Plate ampere rating. If in doubt, use the next heavier gauge. The smaller the gauge number, the heavier the cord.

Check power cords and extension cords for loose or exposed wires and damaged insulation before using.

Repair or replace as needed before using the power tool.

NOTE: The lower the wire size number, the heavier the wire and the further it will carry current without a voltage drop.

⚠WARNING: Never connect this unit to an electrical power source until all operating instructions have been read and understood.

Table 4. Minimum gauge for cord

Ampere rating (on Name Plate)	15 A
Ext. cord length	Wire gauge size A.W.G. (mm ²)
25 ft. (7.5 m)	14 A.W.G. (2.0 mm ²)
50 ft. (15 m)	12 A.W.G. (3.5 mm ²)

8-8. Cutting Work

Precautions on cutting work are provided in the Instruction Manual. Read them carefully and advise the user on correct operation. In this section, important items and the items not described in the Instruction Manual are explained to help you advise the user.

- (1) For cutting work, be sure to use the saw blade guard and check that everything functions properly.
 - ① Check that the saw blade guard rises smoothly.
 - ② Remove wood chips in the guard and wipe off the swarf on the guard with a soft cloth.
 - ③ Check that the dislodging preventive claw (anti-kickback pawls) works normally and is sharp at the tips.
 - ④ Check that the screw fastening the spreader is not loose.
- (2) When using the miter gauge and rip fence, be sure to secure them firmly before starting operation.
- (3) Before starting operation, be sure to tighten the tilt lock handle for raising and tilting saw blade.
- (4) Remove the swarf in the miter-gauge groove.
- (5) Do not raise the saw blade excessively.

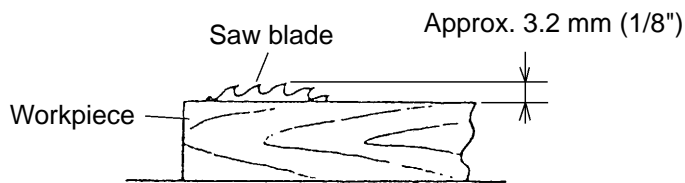

Fig. 20

As shown in Fig. 20, raise the saw blade about 3.2 mm (1/8") above the workpiece to be cut. Excessive raising may cause dislodging of the workpiece.

- (6) The standard precision values are provided in 10-5. Product Precision.

Advise the user to check the precision before starting cutting work. If the precision is insufficient, it may cause dislodging of the workpiece or other unexpected accidents, resulting in poor cutting precision.
- (7) The set nut securing the saw blade is naturally tightened.

Advise the user to check the set nut is firmly tightened before starting operation, and also to remove the plug at this time.
- (8) Use of work helpers.

Assembling and procedures for use of work helpers:
Work helpers are essential for safe operation. Give careful advice on this point. Many books are available on the market relating to work helpers and use of table saws. Recommend the user to purchase such books.

9. MAINTENANCE AND INSPECTION

⚠WARNING: To avoid an accident or personal injury, always confirm that the switch is turned OFF and that the power plug has been disconnected from the receptacle before performing any maintenance or inspection of this tool.

9-1. Inspecting the Saw Blade

Always replace the saw blade immediately upon the first sign of deterioration or damage. A damaged saw blade can cause personal injury and a worn saw blade can cause ineffective operation and possible overload to the motor.

⚠CAUTION: Never use a dull saw blade. When a saw blade is dull, its resistance to the hand pressure applied by the tool handle tends to increase, making it unsafe to operate the power tool.

9-2. Inspecting the Carbon Brushes (Fig. 21 and Fig. 22)

The carbon brushes in the motor are expendable parts. If the carbon brushes become excessively worn, motor trouble might occur. Therefore, inspect the carbon brushes periodically and replace them. Check the carbon brushes after the first 50 hours of use for a new machine or after a new set of carbon brushes have been installed. After the first check, examine them after about every 10 hours of use until such time that replacement is necessary. When the carbon on either brush is worn to 5 mm (3/16") in length or if either spring or shunt wire is burned or damaged in any way, replace both carbon brushes (see Fig. 21). If the carbon brushes are found to be serviceable after removing, reinstall them in the same position as before. Also, keep the carbon brushes clean so that they will slide smoothly within the brush holders. The carbon brushes can easily be removed after removal of the brush caps (see Fig. 22) with a flatblade screwdriver.

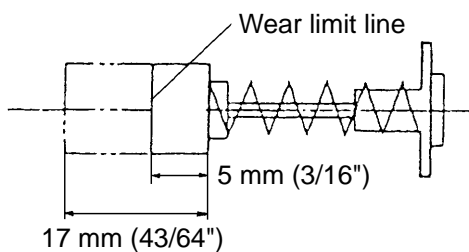

Fig. 21

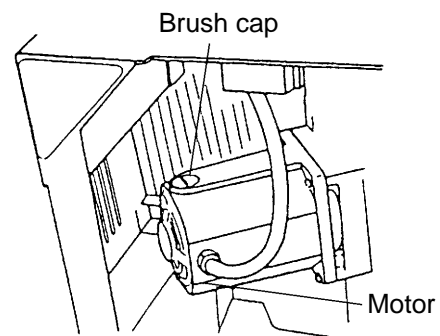

Fig. 22

9-3. Inspecting the Mounting Screws

Regularly inspect each component of the power tool for looseness. Re-tighten mounting screws on any loose part.

⚠WARNING: To prevent personal injury, never operate the power tool if any components are loose.

9-4. Inspecting the Saw Blade Guard for Proper Operation

Before each use of the tool, test the saw blade guard to assure that it is in good condition and that it moves smoothly. Never use the tool unless the saw blade guard operates properly and unless it is in good mechanical condition. Ensure the anti-kickback pawls are always sharp so they dig into the workpiece and avoid kickback. If any damage has occurred, repair it promptly.

9-5. Regular Cleaning of the Saw Blade Guard

Wipe off saw dust attached to the inside of the see-through saw blade guard using a soft cloth. Do not use solvent (gasoline, thinner etc.), solvents will damage plastic parts.

9-6. Storage

Confirm that the switch is turned OFF, that the power plug has been removed from the receptacle and that the safety key has been removed and stored in a secure place, after operation of the saw has been completed.

When the saw is not in use, keep it stored in a dry place out of the reach of children.

9-7. Lubrication

Lubricate the following moving parts and rotating parts once a month to keep the saw in good operating condition for a long time. Use of machine oil is recommended.

Oil supply points: Rotary and moving portion of wheel

9-8. Cleaning

Periodically remove chips and other waste material from the surface of the saw with a damp, soapy cloth.

To avoid a malfunction of the motor, protect it from contact with oil or water.

10. PRECAUTIONS IN DISASSEMBLY AND REASSEMBLY

Please follow the precautions below for disassembly and reassembly procedures. The circled numbers in the following figures and the **[Bold]** numbers in the descriptions below correspond to the item numbers in the Parts List and exploded assembly diagrams.

⚠ CAUTION: Prior to attempting disassembly or replacement of the saw blade, ensure that the power cord plug is disconnected from the power source.

10-1. Disassembly

A. Disassembly of the saw blade section

Tools required:

- Phillips head screwdriver
- 10 mm Wrench
- 22 mm Wrench (standard accessory)
- 23 x 26 mm Wrench (standard accessory)

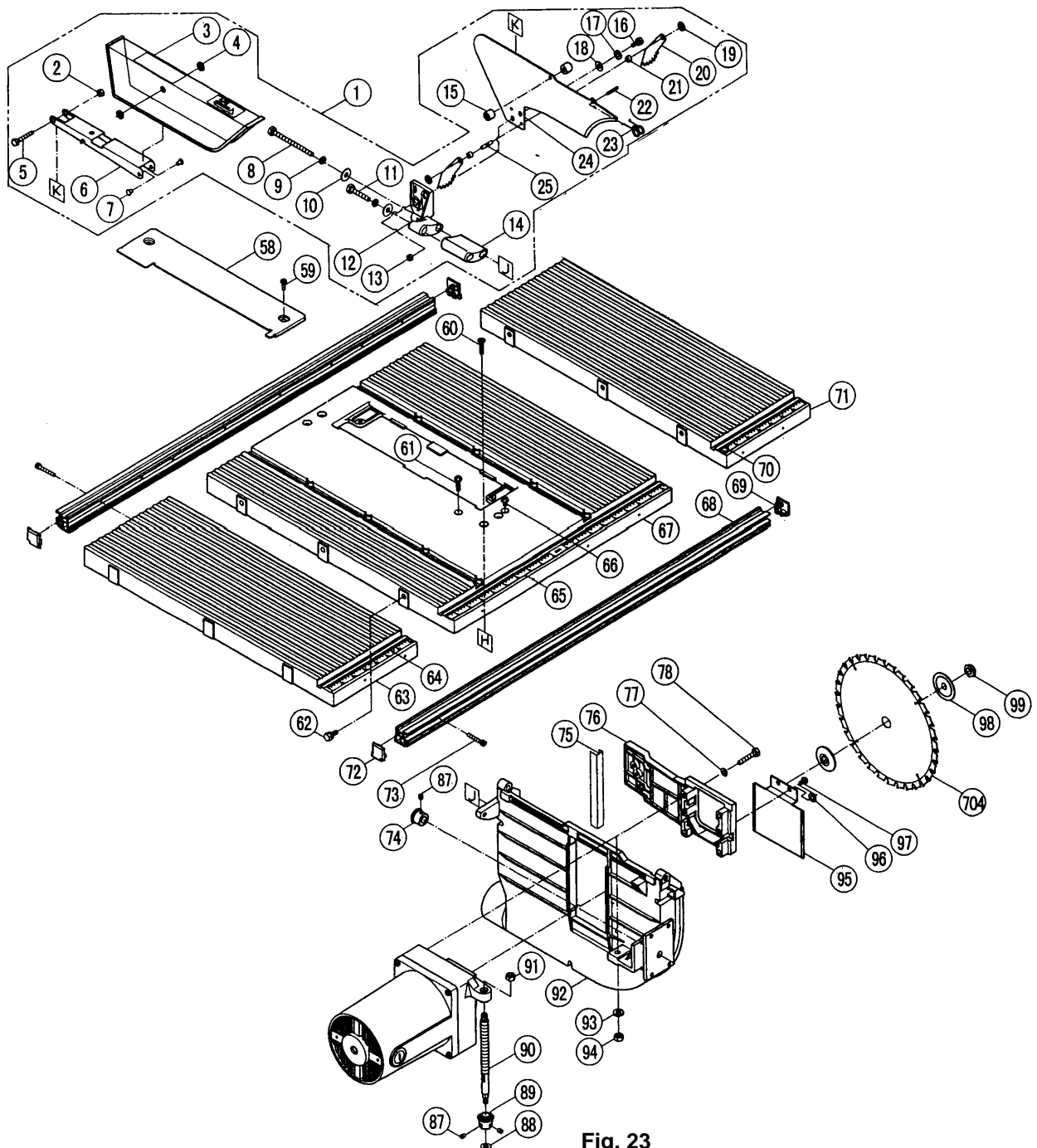

Fig. 23

- (1) Remove the M6 x 110 Bolt [8] and M6 x 90 Bolt [11] using a 10 mm wrench, and remove the Saw Blade Guard and Spreader Assembly (Blade Guard [3] and Spreader [24]).
- (2) Remove the two M5 x 8 Machine Screws [59] and remove the Table Insert [58].
- (3) Put the 22 mm wrench (standard accessory) on the Spindle Ass'y [201] to hold it. Then, put the 23 mm end of the 23 x 26 mm wrench (standard accessory) on the Set Nut [99]. Turn it counterclockwise to remove the nut, and remove Washer (A) [98], the TCT Saw Blade [704] and Washer (A) [98] in this order.

Refer to Fig. 28 for the part numbers of the 200 level.

B. Disassembly of the switch section

Tools required:

- Phillips head screwdriver

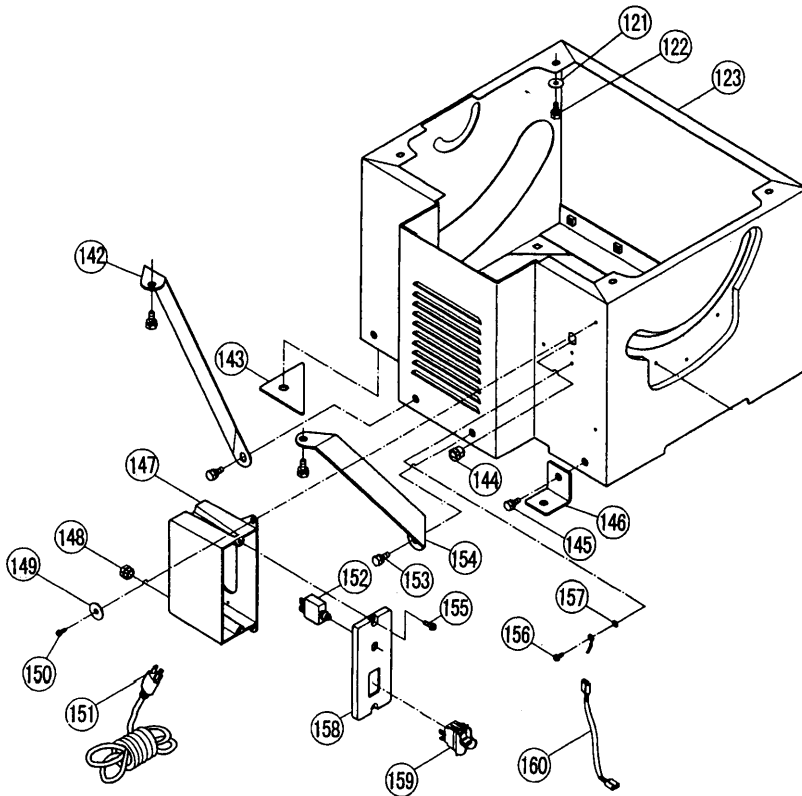

Fig. 24

- (1) Remove the two D5 x 16 Tapping Screws [155] and remove the Switch plate [158]. Then, detach each lead wire connected to the Circuit Breaker Switch [152] and Rocker Switch [159].

(2) Remove the three D4 x 10 Tapping Screws [150] and remove the Switch Box [147]. Then, remove the two D4 x 8 Pan Hd.Tapping Screws [156] and detach the ground wire (green/yellow).

C. Disassembly of the motor and wheel sections

Tools required:

- Phillips head screwdriver
- Flatblade screwdriver
- 3 mm Hexagon bar wrench
- 10 mm and 12 mm Wrenches
- Plastic hammer

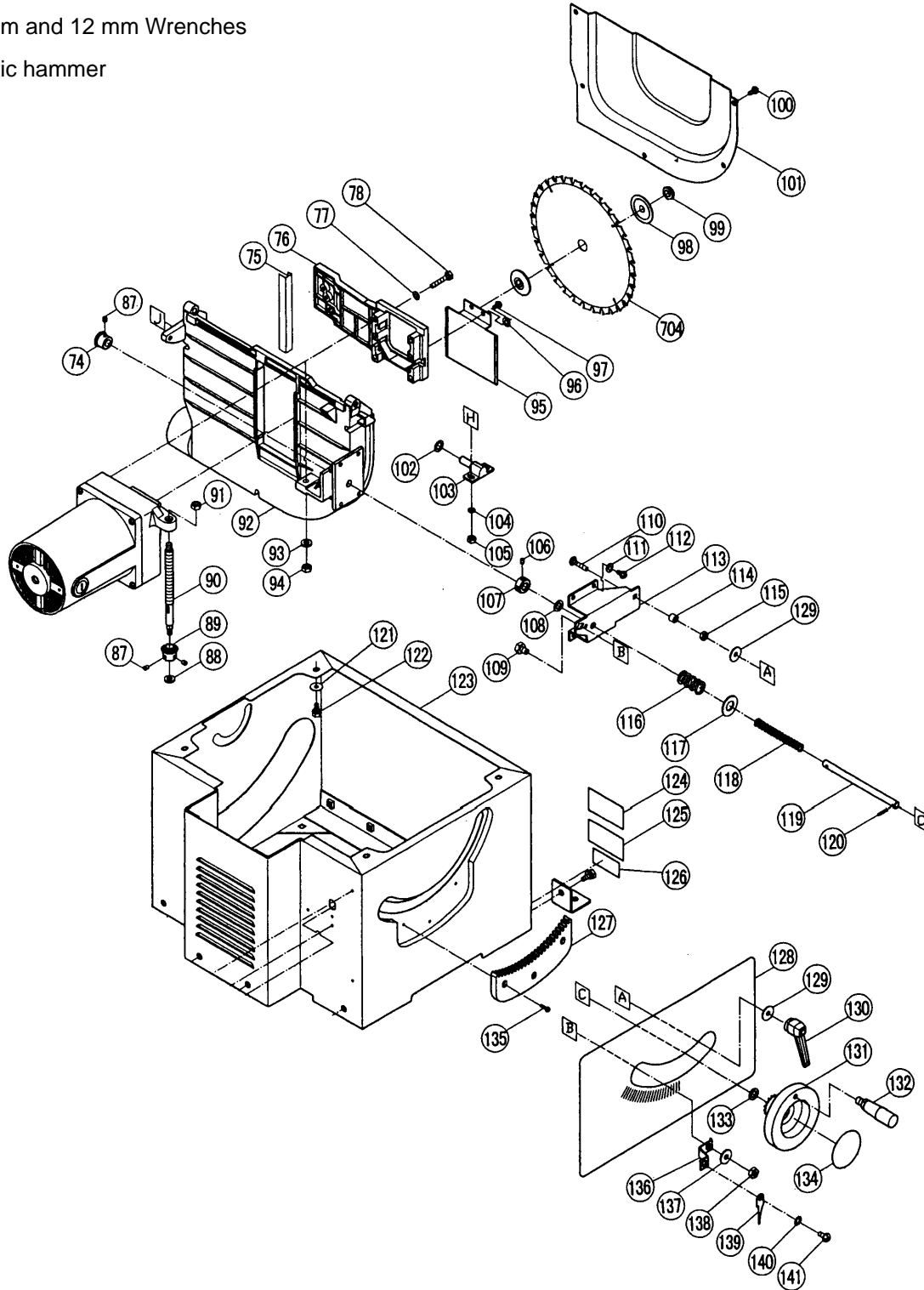

Fig. 25

- (1) Turn the Wheel **[131]** counterclockwise and move the motor to the lower limit position. Turn the Tension Handle **[130]** counterclockwise to loosen and tilt the motor at an angle of 45 degrees. Turn the Tension Handle **[130]** clockwise to tighten. Then, turn the body (Table **[67]** surface upside down.)
- (2) Remove the two Brush Caps **[220]** and remove the two Carbon Brushes **[221]**.
- (3) Remove the four M5 x 30 Machine Screws **[225]**, and remove the Housing Ass'y **[222]** (including the Stator **[218]**), Baffle **[215]**, and Armature Ass'y **[212]** in this order.
- (4) Hold the Strain Relief **[227]** with the pliers and pull it out from the Housing Ass'y **[222]**.
- (5) Remove the two D5 x 60 Tapping Screws **[216]**. Then, detach the lead wire of the Stator **[218]** from the Brush Holder **[223]**, and the ground wire connector on the Stator **[218]**. And, while lightly striking the mounting surface of the Bracket **[211]** of the Housing Ass'y **[222]** with the plastic hammer, draw out the Stator **[218]**.
- (6) Loosen the two M6 x 6 Hex. Socket Set Screws **[106]** securing the Anchor Block **[107]** and the two M6 x 6 Hex. Socket Set Screws **[87]** securing Bevel Gear (A) **[74]**. Remove the Wheel **[131]**, the M 9.5 Flat Washer **[133]**, the Regulating Bolt **[119]**, the 57L Compression Spring **[118]**, the M16 Flat Washer **[117]**, the 20L Compression Spring **[116]**, the M9.5 Flat Washer **[108]**, the Anchor Block **[107]** and Bevel Gear (A) **[74]**.
- (7) Remove the M8 x 16 Bolt (with/Washers) **[109]** using a 12 mm wrench, and remove the Pointer Bracket **[136]** (including the Needle Pointer **[139]**).
- (8) Turn the Tension Handle **[130]** counterclockwise to loosen, and remove it.
- (9) Loosen the M6 Nut **[115]** using a 10 mm wrench, and remove the M6 x 25 Flat Washer **[129]**, the Spacer **[114]**, and the M6 x 35 Special Bolt **[110]**.

Refer to Fig. 28 for the part numbers of the 200 level.

D. Disassembly of the body and spindle sections

Tools required:

- Phillips head screwdriver
- 3 mm Hexagon bar wrench
- 8 mm, 10 mm and 13 mm Wrenches
- Plastic hammer

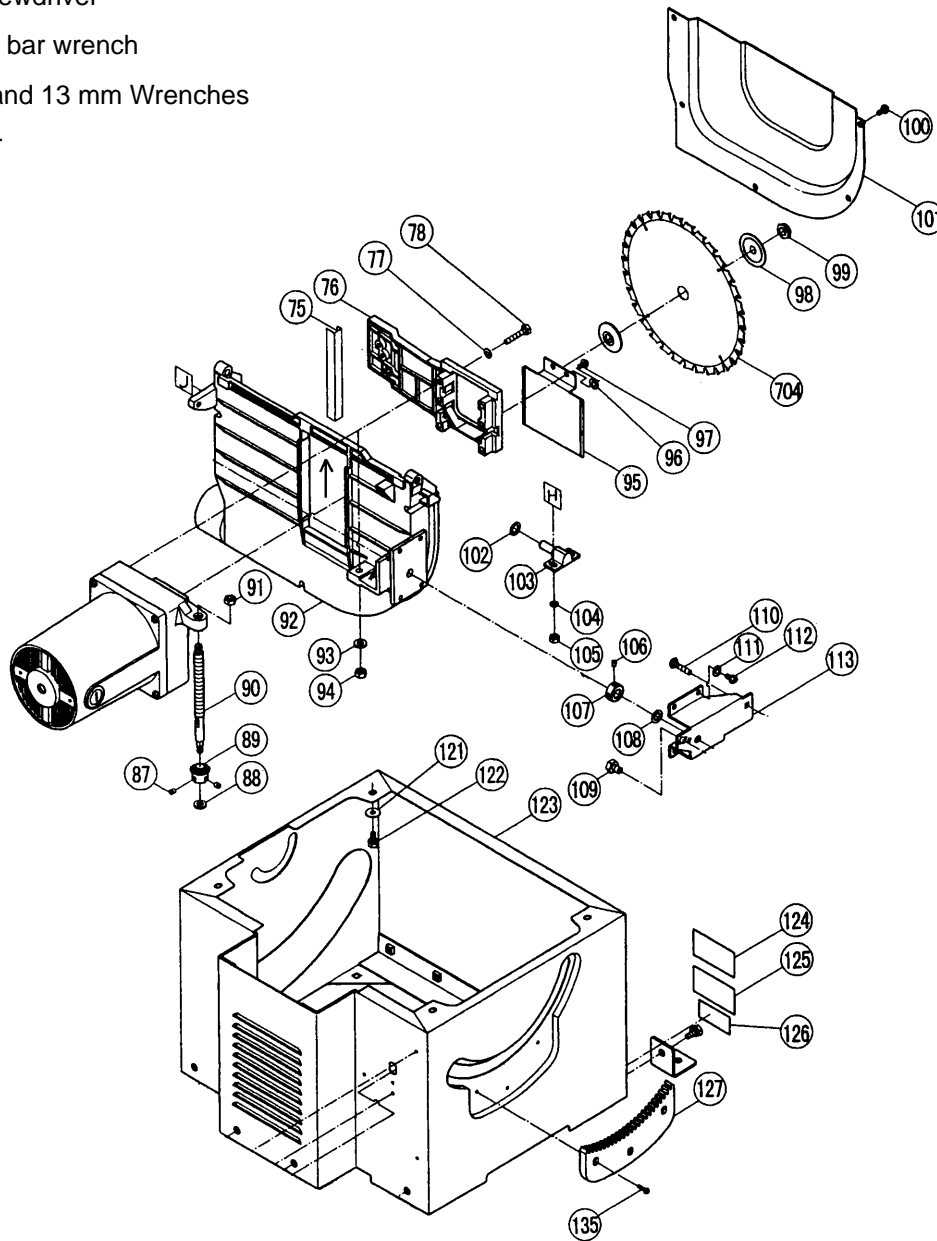

Fig. 26

- (1) Remove the four M6 Nuts [105] using a 10 mm wrench, and remove the Body [92] from the Table [67].
- (2) Remove the four M6 x 12 Machine Screws [112], and remove the Bracket [113].
- (3) Remove the five D5 x 10 Tapping Screws [100], and remove the Blade Guard [101].
- (4) Remove the M6 x 12 Machine Screw [97], and remove the Guard [95].
- (5) Hold the Screw Bar [90] using an 8 mm wrench, and remove the M6 Special Nut Chuck [94] with a 10 mm wrench.
- (6) Slide the Bracket [211] upward (in the direction of the arrow in Fig. 26) and loosen the two M6 x 6 Hex. Socket Set Screws [87]. Remove the M8 x 14.3 Flat Washer [88] and Bevel Gear (B) [89] from the Screw Bar [90].
- (7) Remove the four M6 x 35 Bolts [78] using a 10 mm wrench, and remove the Slide Bracket [76] and Bracket [211].

- (8) Remove the four M4 x 12 Machine Screws [203], and remove the Bearing Retainer [205].
- (9) Remove the Spindle Ass'y [201] by striking the Bracket [211] with a plastic hammer.
- (10) Hold the Screw Bar [90] using an 8 mm wrench, and remove the M8 Nut Chuck [91] with a 13 mm wrench.
Remove the Screw Bar [90] from the Bracket [211].
- (11) Loosen the eight M8 x 20 Bolts (with Washers) [153] which fix Extension Supporter (L) [142] and Extension Supporter (R) [154] with a 13 mm wrench and remove them.
- (12) Remove the four M6 x 12 Bolts (with Washers) [122] using a 10 mm wrench, and remove the Body Shell [123] from the Table [67].

Refer to Fig. 28 for the part numbers of the 200 level.

E. Disassembly of the rip fence section (fence ass'y)

Tools required:

- Phillips head screwdriver
- Pliers
- 5 mm Hexagon bar wrench

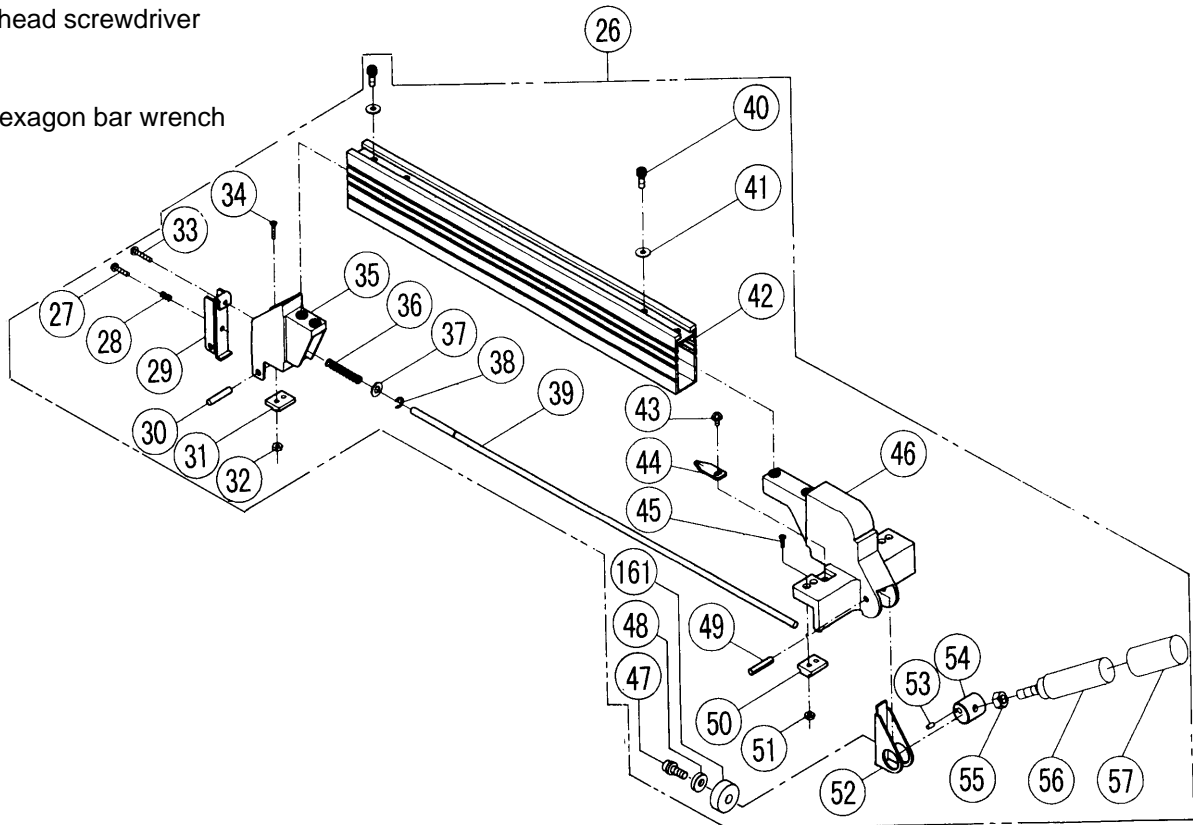

Fig. 27

- (1) Loosen the two M6 x 16 Hex. Socket Hd. Bolts [40] which fix the Support [35] to the Parallel Bracket [42] with a 5 mm hexagon bar wrench to remove the Support [35]. Be careful not to make the 57L Compression Spring [36] fly out of the Support [35].
- (2) Extract the Locking Rod [39] together with the 5/16" x 5/8" Flat Washer [37] being careful not to lose it.
- (3) Loosen the two M6 x 16 Hex. Socket Hd. Bolts [40] which fix the Width Body [46] to the Parallel Bracket [42] with a 5 mm hexagon bar wrench to remove the Width Body [46].
- (4) Loosen the M5 x 12 Machine Screw [47] and remove the Rubber Stopper [161].

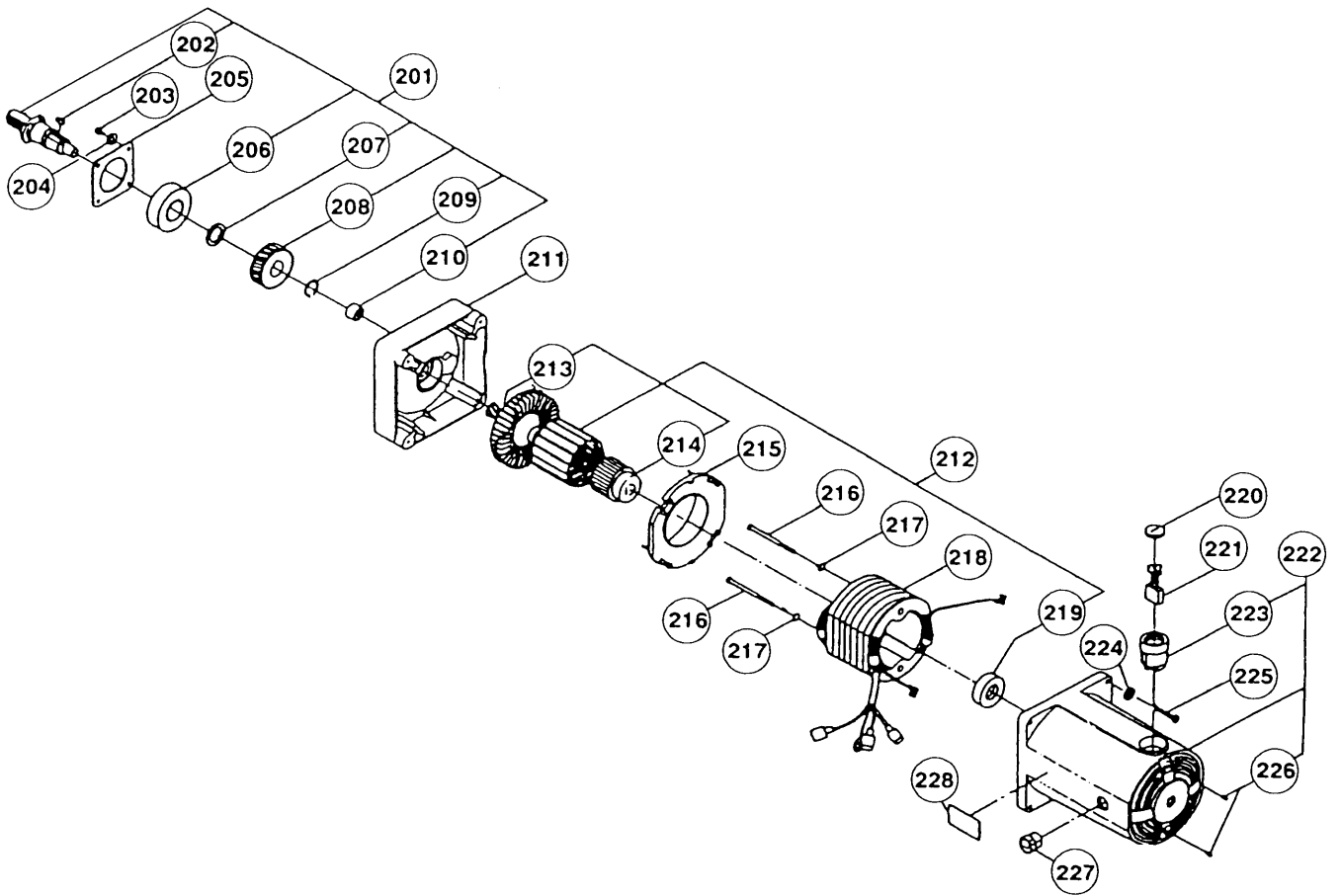

Fig. 28

10-2. Reassembly

Perform reassembly in reverse order of disassembly while observing the following precautions.

(1) Prior to reassembly, measure the insulation resistance of the armature ass'y, stator ass'y, switch and other electrical components with a DC 500 V Megohm Tester, and confirm that the insulation resistance of each part is more than 5 MΩ.

(2) Dielectric strength test

After testing the insulation resistance, apply 1,200 volts between the blade of the Power Cable [151] and the Body Shell [123] for one second with the Rocker Switch [159] ON, to check that no dielectric breakdown will take place.

(3) No-load current value

The figures indicated below are the no-load current values after the machine is operated without load for 30 minutes.

No-load current (max.): 6.2 A at AC single phase 115 V, 60 Hz

(4) When assembling the Slide Plate [75], see Fig. 29 for the direction in which it is mounted on the Body [92].

Thoroughly wipe off the old grease on the sliding portion between the Slide Plate [75], and the Slide Bracket [76] and Bracket [211].

Then apply two grams of motor grease No. 29 (Code No. 930035) there. Thoroughly wipe off the old grease in the gear box of the Bracket [211], and apply two grams of motor grease No. 29 (Code No. 930035) to the Needle Bearing [210]. Also thoroughly wipe off the old grease on teeth of the Helix Gear [208] in the Spindle Ass'y [201], pinion of the Armature Ass'y [212], thread portion of the Screw Bar [90], and teeth of Bevel Gear (A) [74] and Bevel Gear (B) [89]. Then apply motor grease No. 29 (Code No. 930035).

Refer to Fig. 28 for the part numbers of the 200 level.

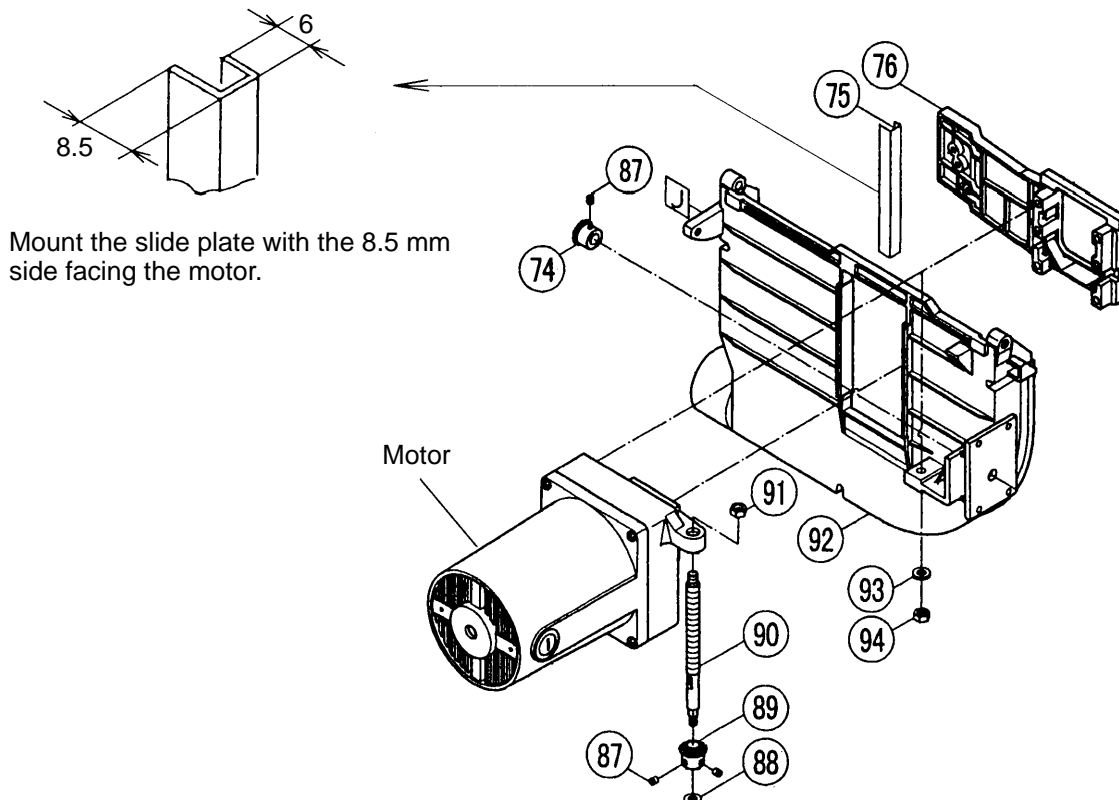

Fig. 29

10-3. Wiring

Wiring should be performed as shown in Fig. 30. Please note that incorrect wiring will result in a failure in rotation.

(1) Wiring diagram

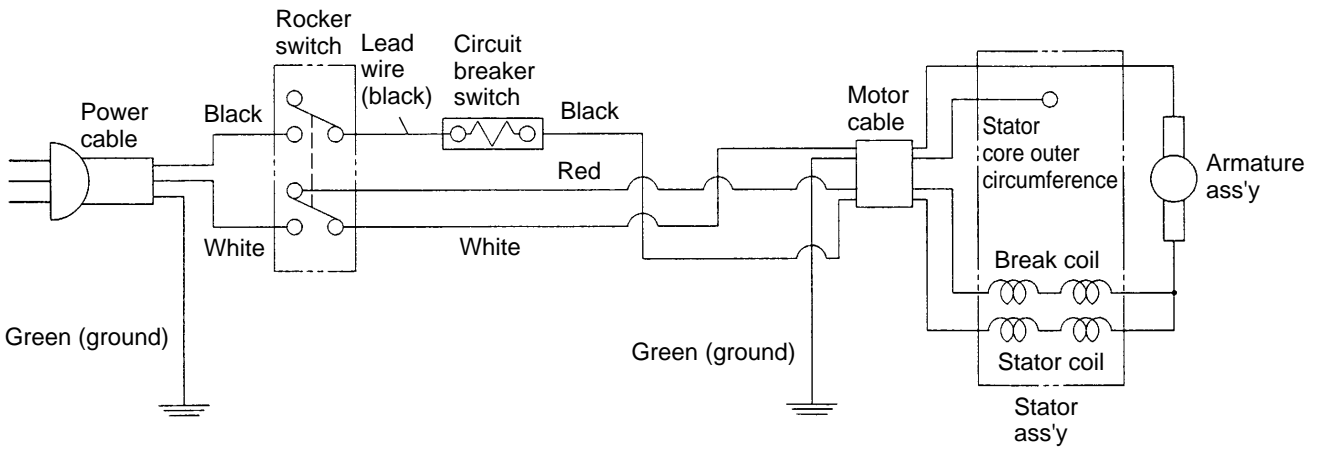

Fig. 30

(2) Lead wire arrangements

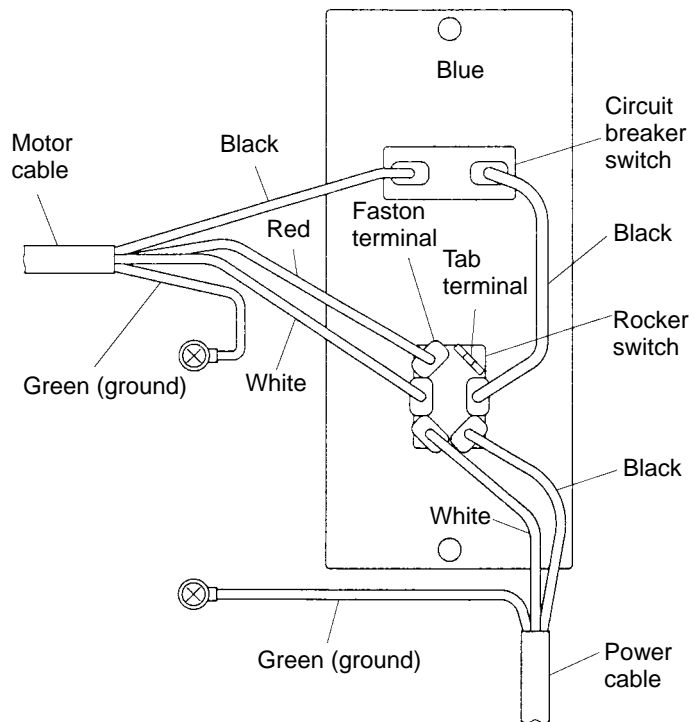

Fig. 31

When connecting each lead wire to the circuit breaker, and rocker switch, the faston terminals must be completely inserted into the corresponding tab terminals.

10-4. Adjustments

After disassembly and reassembly, the following parts require adjustment.

After being disassembled and reassembled, the affected items should be adjusted. For adjustment, see the adjusting method described in 8-3. Adjustment on page 12.

- (1) Parallel alignment of the saw blade and the miter-gauge groove
- (2) Saw blade squareness and tilting 45° stopper position
- (3) Parallel alignment of the rip fence and the miter-gauge groove
- (4) Pointer position of the rip fence
- (5) Squareness between the miter gauge and the saw blade
- (6) Position of the spreader with respect to the saw blade (see 8-2-4 (2) Adjusting the spreader on page 11.)

10-5. Product precision

After the reassembly is completed, check the precision of the product.

(Unit: mm/mm)

Item	
Run out of dummy disc	0.38/230
Squareness between dummy disc and table upper surface	0.4/60
Parallelism between dummy disc and miter-gauge groove	0.4/200
Parallelism between dummy disc and rip fence	1.0/200

11. REPAIR GUIDE

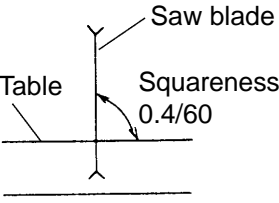
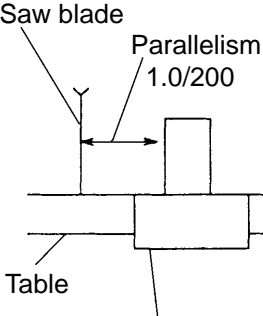
No	Problem	Possible cause	Factory rated value	Remedy
1	<p>Low cutting accuracy – poor squareness of cut surface</p>  <p>(Note) Unit: mm/mm Fig. 32</p>  <p>(Note) Unit: mm/mm Fig. 33</p>	a) Because of poor squareness between the table and saw blade, the saw blade enters the material at a slant.	0.4/60 (Dummy disc) (Fig. 32)	<ul style="list-style-type: none"> • Readjust the squareness of the saw blade using the M6 x 20 Seal Lock Screw [61].
		b) Large run out of saw blade (Large vibration)	0.38/230 (Dummy disc)	<ul style="list-style-type: none"> • Replace the Saw Blade [704]. • Check Washer (A) [98] for dents, etc. If any, remove with a file. • Replace Washer (A) [98].
		c) Poor parallelism of table upper surface	1.0 /200 or under	<ul style="list-style-type: none"> • Replace the Table [67].
		d) Poor parallelism between the table and the extension wing	1.5/200 or under	<ul style="list-style-type: none"> • Loosen the M8 x 20 Bolt (W/ Washers) [153], M6 x 35 Hex. Socket Hd. Cap Bolt [73] and readjust the parallelism between the Table [67], and Extension Wing (R) [71] and Extension Wing (L) [63]. • Replace Extension Wing (R) [71] or Extension Wing (L) [63].
		e) Poor parallelism between the miter-gauge groove and saw blade	0.4/200 (Dummy disc)	<ul style="list-style-type: none"> • Loosen the M6 x 25 Flat Hd. Screw [60], and readjust the parallelism between the miter-gauge groove and the saw blade.
		f) Poor parallelism between the rip fence and saw blade	1.0/200 (Dummy disc) (Fig. 33)	<ul style="list-style-type: none"> • Loosen the M6 x 16 Hex. Socket Hd. Bolt [40], and readjust the parallelism between the rip fence and the saw blade.
		g) A too fast cutting speed causes the saw blade to deflect and results in low accuracy.	—	<ul style="list-style-type: none"> • Slow down the cutting speed. (Proper speed is 7 seconds for 50 mm rectangular lumber.)
		h) Excessive force is applied because of a dull saw blade.	—	<ul style="list-style-type: none"> • Sharpen the Saw Blade [704]. • Replace the Saw Blade [704].
		i) Deformation of the material such as a curvature or bend causes the material to move during cutting.	—	<ul style="list-style-type: none"> • Correct the curvature or bend by planing the material, and cut again.

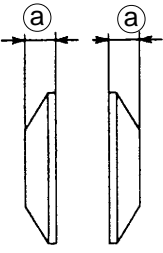
No	Problem	Possible cause	Factory rated value	Remedy								
2	Poor cut surface Parallelism (a) = 0.02/63  Washer (A) (Note) Unit: mm/mm Fig. 34	a) Large run out of saw blade (Large run out results in poor cut grain.)	(Dummy disc)	• Same as item No. 1, b).								
		b) Poor parallelism of washer (A) due to dents or flaws	Washer (A) (Fig. 34)	• Remove dents or flaws on Washer (A) [98], or replace.								
		c) Cutting speed too fast.	—	• Slow down the cutting speed.								
		d) During cutting, the material becomes rough because of its curvature, bend, etc.	—	• Eliminate the curvature, bend, etc. in the material by planing.								
3	The saw blade locks up.	a) Cutting speed too fast.	—	• Slow down the cutting speed.								
		b) Thin extension cord	—	The usable extension cords are as follows: <table border="1" data-bbox="1034 929 1428 1142"> <thead> <tr> <th>Ampere rating</th> <th>15</th> </tr> <tr> <th>Ext. cord length</th> <th>Wire gauge size</th> </tr> </thead> <tbody> <tr> <td>25 ft. (7.5 m)</td> <td>14 A.W.G. (2.0 mm²)</td> </tr> <tr> <td>50 ft. (15 m)</td> <td>12 A.W.G. (3.5 mm²)</td> </tr> </tbody> </table>	Ampere rating	15	Ext. cord length	Wire gauge size	25 ft. (7.5 m)	14 A.W.G. (2.0 mm ²)	50 ft. (15 m)	12 A.W.G. (3.5 mm ²)
		Ampere rating	15									
		Ext. cord length	Wire gauge size									
		25 ft. (7.5 m)	14 A.W.G. (2.0 mm ²)									
50 ft. (15 m)	12 A.W.G. (3.5 mm ²)											
c) Excessive force is applied because of a dull saw blade.	—	• Shapen the Saw Blade [704]. • Replace the Saw Blade [704].										
d) Wrong selection of saw blade	—	• Use a genuine Hitachi saw blade. • The higher the number of teeth of a saw blade, the more cutting resistance increases. Where a saw blade with many teeth is used, cut slowly.										
e) During cutting, the material binds the saw blade because of a deformation such as curvature and bend.	—	• Eliminate the curvature, bend, etc. in the material by planing.										

No	Problem	Possible cause	Factory rated value	Remedy								
4	The saw blade won't turn even if the switch is turned on.	a) Power cord is not connected to the power outlet.	—	<ul style="list-style-type: none"> • Check the power voltage. • Plug the power cord into the outlet. 								
		b) Wear of the carbon brushes has exceeded the wear limit (5 mm).	—	<ul style="list-style-type: none"> • Check the Carbon Brushes [221]. • Replace the Carbon Brushes [221]. 								
		c) Switch failure	—	<ul style="list-style-type: none"> • Check the Rocker Switch [159] or the Circuit Breaker Switch [152] for continuity. • Replace the Rocker Switch [159] or the Circuit Breaker Switch [152]. 								
		d) The circuit breaker switch activated.	—	<ul style="list-style-type: none"> • Press the reset button after 2 to 3 minutes. 								
5	Slow saw blade rotation. The saw blade speed is less than 5,000 /min.	a) Power voltage lower than rated voltage.	4,500 – 5,500 /min	<ul style="list-style-type: none"> • Check the power voltage. • Check if the extension cord used is nonstandard. The usable extension cords are as follows: <table border="1" style="margin-left: 20px;"> <thead> <tr> <th>Ampere rating</th> <th>15</th> </tr> <tr> <th>Ext. cord length</th> <th>Wire gauge size</th> </tr> </thead> <tbody> <tr> <td>25 ft. (7.5 m)</td> <td>14 A.W.G. (2.0 mm²)</td> </tr> <tr> <td>50 ft. (15 m)</td> <td>12 A.W.G. (3.5 mm²)</td> </tr> </tbody> </table>	Ampere rating	15	Ext. cord length	Wire gauge size	25 ft. (7.5 m)	14 A.W.G. (2.0 mm ²)	50 ft. (15 m)	12 A.W.G. (3.5 mm ²)
Ampere rating	15											
Ext. cord length	Wire gauge size											
25 ft. (7.5 m)	14 A.W.G. (2.0 mm ²)											
50 ft. (15 m)	12 A.W.G. (3.5 mm ²)											
6	Fast saw blade speed. The saw blade speed is more than 5,000 /min.	a) Power voltage higher than rated voltage.	4,500 – 5,500 /min	<ul style="list-style-type: none"> • Check the power voltage. 								

12. STANDARD REPAIR TIME (UNIT) SCHEDULES

MODEL	Variable		10	20	30	40	50	60	70 min.
	Fixed								
C 10RA2		Work Flow							
		Extension Wing (L) Extension Wing (R)							
		General Assembly							
		Circuit Breaker Switch Switch Plate Rocker Switch Power Cable		Switch Box					
	Blade Guard Ass'y } Spreader } Switch plate } Other: 10 min.	0 min.							
	Spreader TCT Saw Blade Washer (A) Blade Guard	Pivot Support Anchor Block Regulating Bolt Wheel Slide Bracket Compression Spring	Segment Gear Hitachi Label Screw Bar Bevel Gear (B)	Bracket	Body			Body Shell Table	
	Carbon Brush						Armature Ass'y Bracket Spindle Ass'y Ball Bearing (6204VV) Helix Gear	Housing Ass'y Stator	

Assembly Diagram for C 10RA2

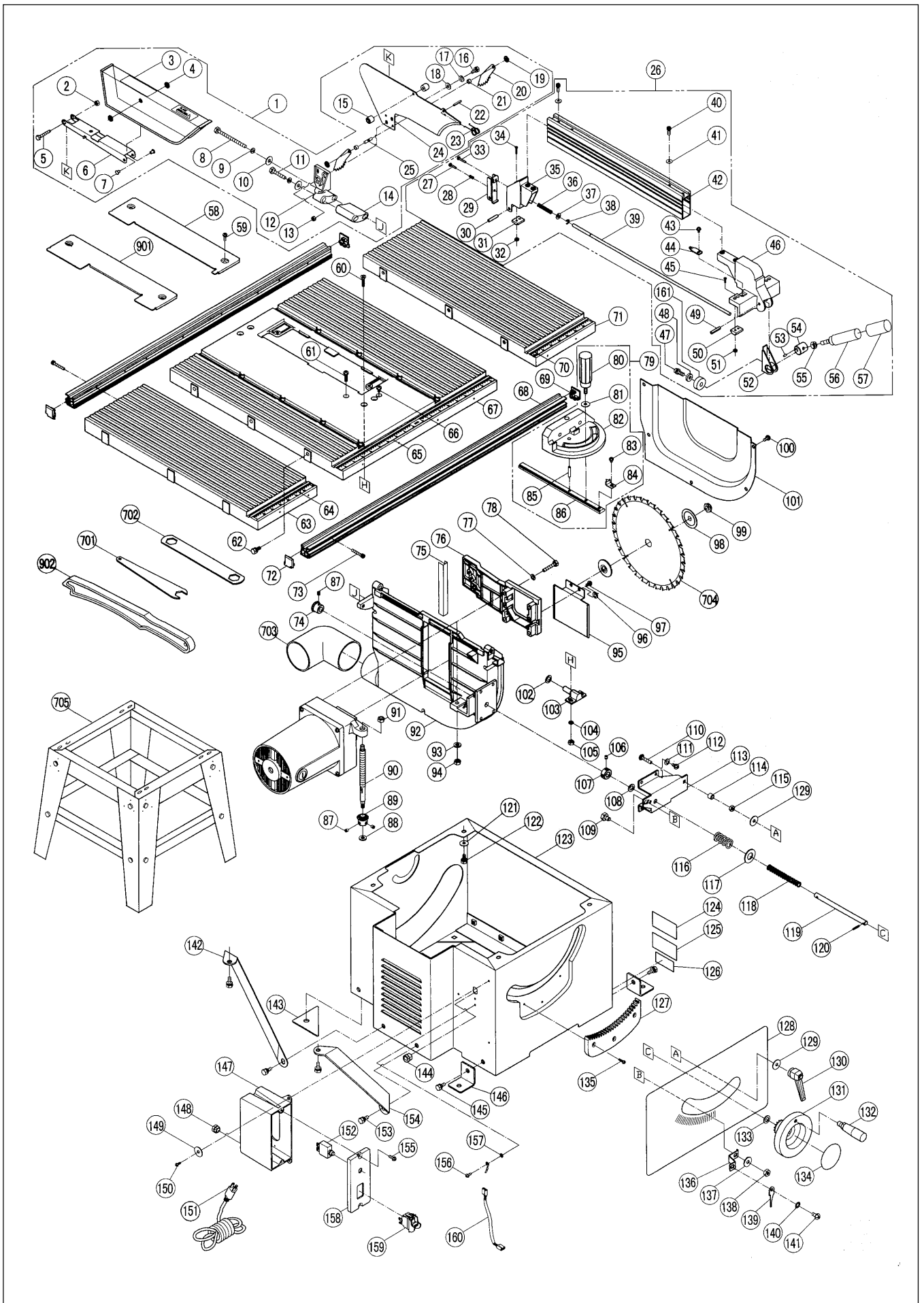

Assembly Diagram for C 10RA2

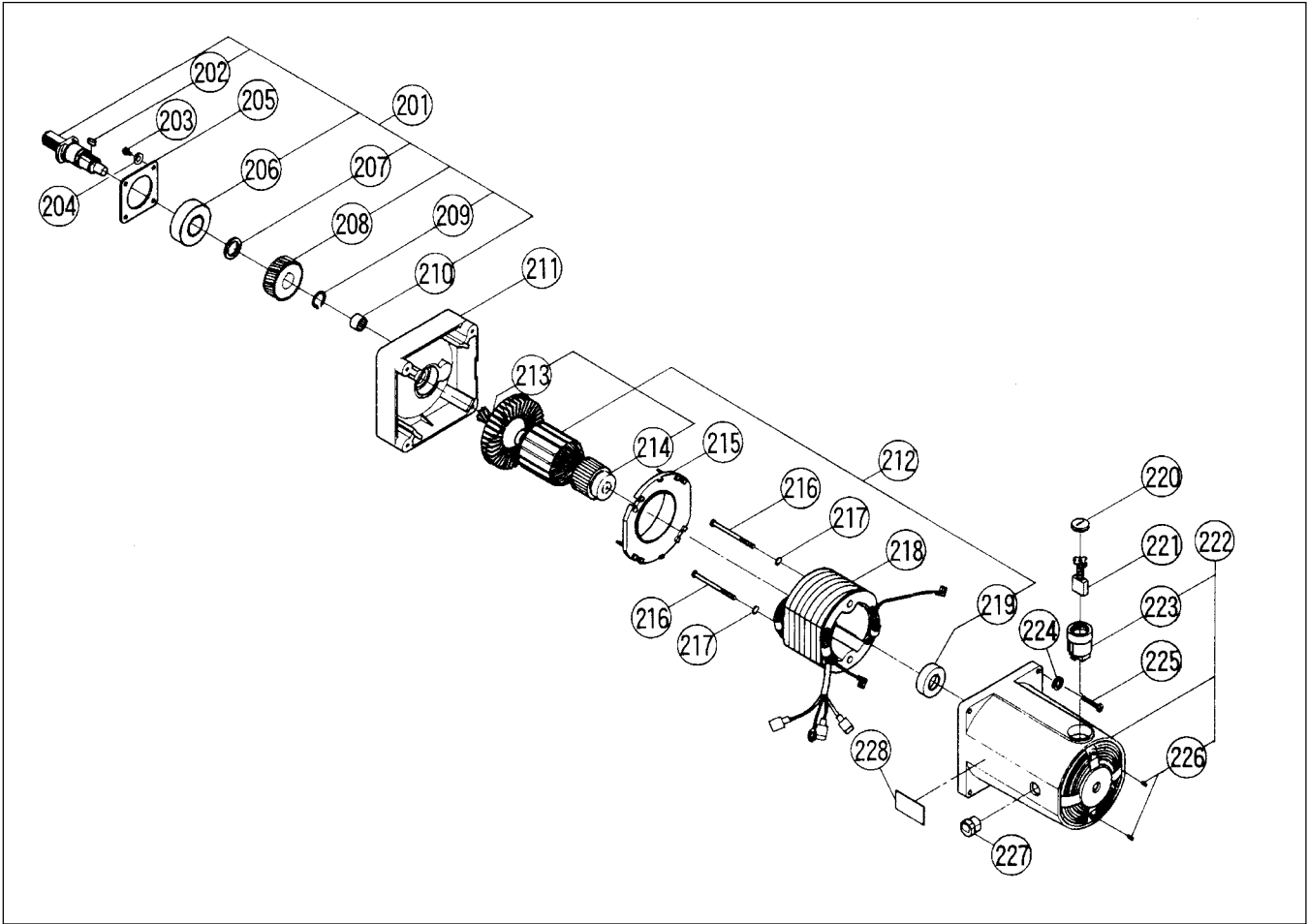

PARTS

C 10RA2

ITEM No.	CODE NO.	DESCRIPTION	NO. USED	REMARKS
1	318-086	BLADE GUARD ASS'Y	1	INCLUD.2-25
2	314-474	NUT CHUCK M6	1	
3	314-479	BLADE GUARD	1	
4	314-476	SELF-LOCKING RING	2	
5	949-644	BOLT M6X40 (10 PCS.)	1	
6	314-477	ARM	1	
7	314-478	RIVET	2	
8	318-088	BOLT M6X110	1	
9	949-455	SPRING WASHER M6 (10 PCS.)	2	
10	949-432	BOLT WASHER M6 (10 PCS.)	2	
11	318-089	BOLT M6X90	1	
12	314-483	GUARD BRACKET	1	
13	949-556	NUT M6 (10 PCS.)	2	
14	318-090	CUSHION	1	
15	314-480	BUSHING	2	
16	949-613	BOLT M6X16 (10 PCS.)	2	
17	949-455	SPRING WASHER M6 (10 PCS.)	2	
18	973-361	WASHER	2	
19	314-476	SELF-LOCKING RING	2	
20	314-444	KICK BACK PAWL	2	
21	314-445	BUSHING	2	
22	949-870	ROLL PIN D4X22 (10 PCS.)	1	
23	314-447	SPRING	1	
24	318-092	SPREADER	1	
25	314-446	ROLL PIN	1	
26	318-093	RIP FENCE ASS'Y	1	INCLUD.27-57,161
27	318-094	TAPPING SCREW D5X25	1	
28	314-555	SEGMENT GEAR	1	
29	318-095	REAR CLAMP	1	
30	318-096	SPRING PIN	1	
31	318-097	SLIDER (REAR)	1	
32	318-098	HEX. NUT M4	2	
33	318-133	PAN HD. SCREW M5X25	1	
34	318-100	COUNTER HD. SCREW M4X20	2	
35	318-101	SUPPORT	1	
36	314-537	COMPRESSION SPRING 57L	1	
37	318-102	FLAT WASHER 5/16"X5/8"	1	
38	318-103	E-RING	1	
39	318-104	LOCKING ROD	1	
40	949-755	HEX. SOCKET HD. BOLT M6X16 (10 PCS.)	4	
41	317-627	FLAT WASHER 1/4"X5/8"	4	
42	318-105	PARALLEL BRACKET	1	
43	317-567	ROUND WASHER HD. SCREW M5X8	1	
44	318-106	NEEDLE POINTER	1	
45	318-107	COUNTER HD. SCREW M4X12	4	
46	318-108	WIDTH BODY	1	
47	949-237	MACHINE SCREW M5X12 (10 PCS.)	1	
48	949-431	BOLT WASHER M5 (10 PCS.)	1	
49	318-096	SPRING PIN	1	
50	318-111	SLIDER (FRONT)	2	
51	318-098	HEX. NUT M4	4	

* : ALTERNATIVE PARTS

7 - 99

PARTS

C 10RA2

ITEM No.	CODE NO.	DESCRIPTION	NO. USED	REMARKS
52	318-113	CLAMPER	1	
53	318-114	RUBBER BUSHING	1	
54	318-115	ECCENTRIC SHAFT	1	
55	949-558	NUT M8 (10 PCS.)	1	
56	318-116	CLAMP BOLT	1	
57	318-117	GRIP	1	
58	314-484	TABLE INSERT FOR SAW BLADE	1	
59	949-235	MACHINE SCREW M5X8 (10 PCS.)	2	
60	949-342	FLAT HD. SCREW M6X25 (10 PCS.)	4	
61	314-486	SEAL LOCK SCREW M6X20	1	
62	318-118	MACHINE SCREW (W/WASHERS) M6X20	6	
63	318-119	EXTENSION WING (LEFT)	1	
64	318-120	SCALE (LEFT)	1	
65	318-121	SCALE (CENTER)	1	
66	314-490	SEAL LOCK SCREW M6X10	1	
67	318-122	TABLE	1	
68	318-123	RAIL	2	
69	318-124	SIDE COVER (RIGHT)	2	
70	318-125	SCALE (RIGHT)	1	
71	318-126	EXTENSION WING (RIGHT)	1	
72	318-127	SIDE COVER (LEFT)	2	
73	318-128	HEX. SOCKET HD. CAP BOLT M6X35	16	
74	314-512	BEVEL GEAR (A)	1	
75	314-513	SLIDE PLATE	2	
76	314-514	SLIDE BRACKET	1	
77	949-455	SPRING WASHER M6 (10 PCS.)	4	
78	949-803	BOLT M6X35 (10 PCS.)	4	
79	315-042	MITER GAUGE ASS'Y	1	INCLUD.80-86
80	314-505	CLAMP HANDLE (B)	1	
81	314-506	FLAT WASHER M6.4	1	
82	314-507	MITER GAUGE	1	
83	949-234	MACHINE SCREW M5X6 (10 PCS.)	1	
84	314-509	ANGLE POINTER	1	
85	314-510	PIN	1	
86	314-511	SHEET BAR	1	
87	967-469	HEX. SOCKET SET SCREW M6X6	4	
88	314-516	FLAT WASHER M8X14.3	1	
89	314-517	BEVEL GEAR (B)	1	
90	314-518	SCREW BAR	1	
91	314-519	NUT CHUCK M8	1	
92	314-520	BODY	1	
93	314-521	FLAT WASHER M6.4X12.7	1	
94	314-522	SPECIAL NUT CHUCK M6	1	
95	314-523	GUARD	1	
96	949-455	SPRING WASHER M6 (10 PCS.)	1	
97	949-255	MACHINE SCREW M6X12 (10 PCS.)	1	
98	314-454	WASHER (A)	2	
99	318-130	SET NUT	1	
100	317-352	TAPPING SCREW D5X10	5	
101	314-526	BLADE GUARD	1	
102	314-527	FLAT WASHER M8X15	2	

PARTS

C 10RA2

ITEM No.	CODE NO.	DESCRIPTION	NO. USED	REMARKS
103	314-528	PIVOT SUPPORT	2	
104	949-455	SPRING WASHER M6 (10 PCS.)	4	
105	949-556	NUT M6 (10 PCS.)	4	
106	967-469	HEX. SOCKET SET SCREW M6X6	2	
107	314-533	ANCHOR BLOCK	1	
108	314-534	FLAT WASHER M9.5	1	
109	307-410	BOLT (W/WASHERS) M8X16 (BLACK)	1	
110	314-529	SPECIAL BOLT M6X35	1	
111	949-455	SPRING WASHER M6 (10 PCS.)	4	
112	949-255	MACHINE SCREW M6X12 (10 PCS.)	4	
113	314-530	BRACKET	1	
114	314-531	SPACER	1	
115	949-556	NUT M6 (10 PCS.)	1	
116	314-535	COMPRESSION SPRING 20L	1	
117	314-536	FLAT WASHER M16	1	
118	314-537	COMPRESSION SPRING 57L	1	
119	314-538	REGULATING BOLT	1	
120	949-518	ROLL PIN D3X18 (10 PCS.)	1	
121	973-361	WASHER	4	
122	996-577	BOLT (W/WASHERS) M6X12 (BLACK)	4	
123	314-539	BODY SHELL	1	
124		WARNING LABEL (B)	1	
125		WARNING LABEL (A)	1	
126		NAME PLATE	1	
127	314-555	SEGMENT GEAR	1	
128		HITACHI LABEL	1	
129	314-532	FLAT WASHER M6X25	2	
130	314-556	TENSION HANDLE	1	
131	314-557	WHEEL	1	
132	314-558	HANDLE	1	
133	314-534	FLAT WASHER M9.5	1	
134	314-560	LABEL	1	
135	318-131	PAN HD. TAPPING SCREW D4X12	3	
136	314-561	POINTER BRACKET	1	
137	949-433	BOLT WASHER M8 (10 PCS.)	1	
138	949-558	NUT M8 (10 PCS.)	1	
139	314-562	NEEDLE POINTER	1	
140	314-580	TOOTHED LOCK WASHER M5	1	
141	949-235	MACHINE SCREW M5X8 (10 PCS.)	1	
142	314-541	EXTENSION SUPPORTER (L)	2	
143	314-542	SPONGE	4	
144	314-548	STRAIN RELIEF (RA-1418)	1	
145	308-946	BOLT (W/WASHERS) M8X20 (BLACK)	4	
146	314-540	SET PLATE	4	
147	317-285	SWITCH BOX	1	
148	314-544	STRAIN RELIEF (RU-1435)	1	
149	949-429	BOLT WASHER M4 (10 PCS.)	3	
150	314-545	TAPPING SCREW D4X10	3	
151	314-456	POWER CABLE	1	
152	314-457	CIRCUIT BREAKER SWITCH	1	
153	308-946	BOLT (W/WASHERS) M8X20 (BLACK)	8	

* : ALTERNATIVE PARTS

7 - 99

PARTS

ITEM No.	CODE NO.	DESCRIPTION	NO. USED	REMARKS	
154	314-547	EXTENSION SUPPORTER (R)	2		
155	314-549	TAPPING SCREW D5X16	2		
156	318-132	PAN HD. TAPPING SCREW D4X8	2		
157	314-553	TOOTHED LOCK WASHER M4	2		
158	314-458	SWITCH PLATE	1		
159	314-459	ROCKER SWITCH	1		
160	317-158	INTERNAL WIRE	1		
161	318-274	RUBBER STOPPER	1		
201	314-451	SPINDLE ASS'Y	1	INCLUD.202,206-210	
202	314-567	PARALLEL KEY	1		
203	949-217	MACHINE SCREW M4X12 (10 PCS.)	4		
204	949-453	SPRING WASHER M4 (10 PCS.)	4		
205	314-572	BEARING RETAINER	1		
206	620-4VV	BALL BEARING 6204VVCMP2L	1		
207	314-568	COLLAR FOR D17	1		
208	314-569	HELIX GEAR	1		
209	967-261	RETAINING RING FOR D17 SHAFT	1		
210	314-570	NEEDLE BEARING	1		
211	314-575	BRACKET	1		
212	314-452	ARMATURE ASS'Y 115V	1	INCLUD.213,214,219	
213	620-1VV	BALL BEARING 6201VVCMP2L	1		
214	620-0VV	BALL BEARING 6200VVCMP2L	1		
215	314-578	BAFFLE	1		
216	314-579	TAPPING SCREW D5X60	2		
217	314-580	TOOTHED LOCK WASHER M5	2		
218	314-453	STATOR 115V	1		
219	314-577	BEARING BUSHING	1		
220	314-583	BRUSH CAP	2		
221	999-044	CARBON BRUSH (1 PAIR)	2		
222	314-585	HOUSING ASS'Y	1	INCLUD.223,226	
223	314-586	BRUSH HOLDER	2		
224	949-454	SPRING WASHER M5 (10 PCS.)	4		
225	949-245	MACHINE SCREW M5X30 (10 PCS.)	4		
226	967-377	HEX. SOCKET SET SCREW M5X8	2		
227	314-544	STRAIN RELIEF (RU-1435)	1		
228		MOTOR NAME PLATE	1		

STANDARD ACCESSORIES

ITEM No.	CODE NO.	DESCRIPTION	NO. USED	REMARKS	
701	314-590	WRENCH 22MM	1		
702	314-591	WRENCH 23/26MM	1		
703	314-592	ELBOW	1		
704	314-616	TCT SAW BLADE 255MM-D15.88 HOLE-NT36	1		
705	314-819	STAND	1		

OPTIONAL ACCESSORIES

ITEM No.	CODE NO.	DESCRIPTION	NO. USED	REMARKS	
901	314-325	TABLE INSERT FOR CUTTER	1		
902	314-324	PUSH STICK	1		

* : ALTERNATIVE PARTS