

Study & Master

Technology

CAPS

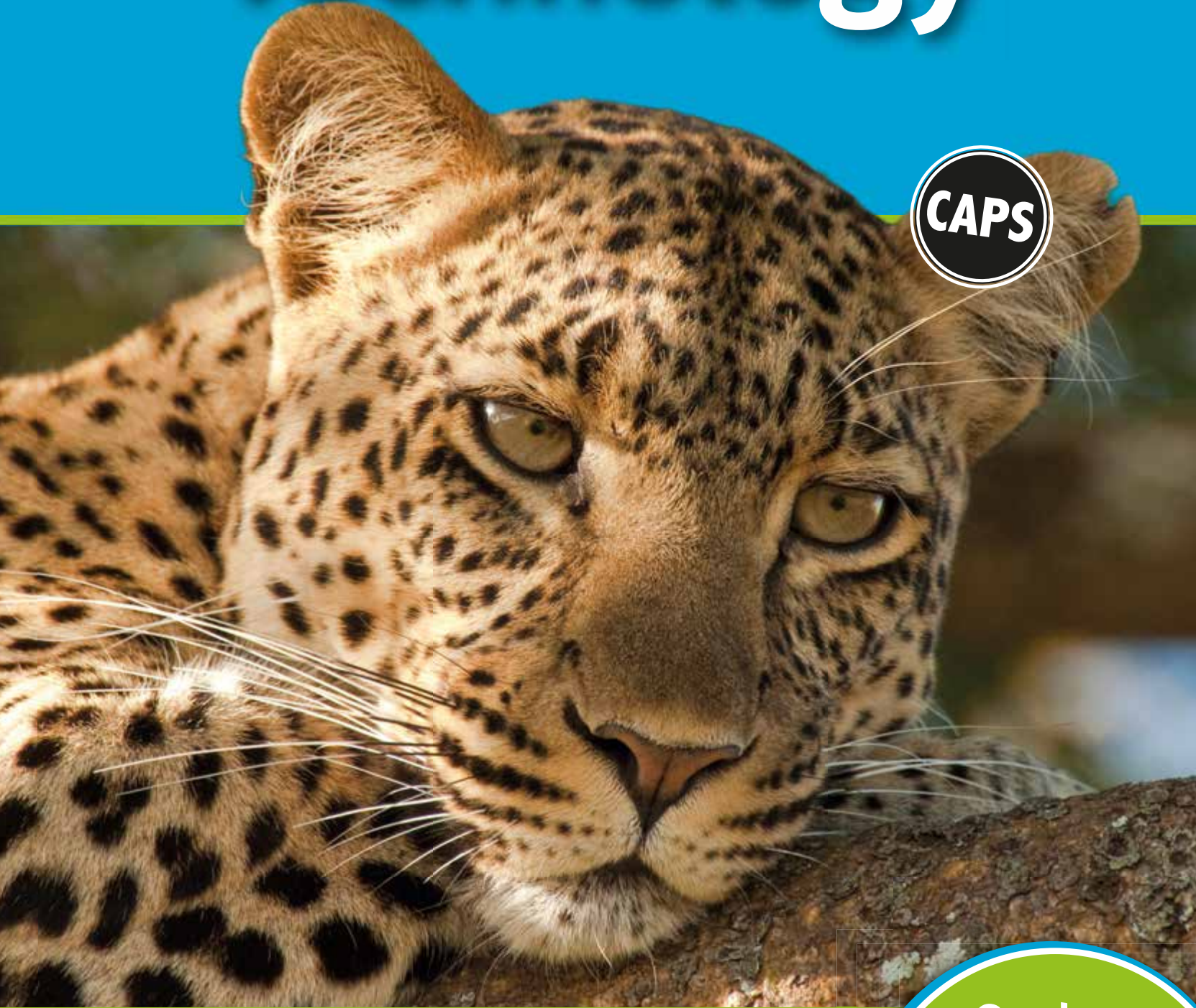

Teacher's Guide

Grade

9

Ria de Jager • Lin Bassett • Neel Ramdutt
Lynn Pocock • Barbara Munsami

Study & Master

Technology

Grade 9 Teacher's Guide

Ria de Jager • Lin Bassett • Neel Ramdutt
Lynn Pocock • Barbara Munsami



CAMBRIDGE
UNIVERSITY PRESS

CAMBRIDGE UNIVERSITY PRESS

Cambridge, New York, Melbourne, Madrid, Cape Town,
Singapore, São Paulo, Delhi, Mexico City

Cambridge University Press
The Water Club, Beach Road, Granger Bay, Cape Town 8005, South Africa

www.cup.co.za

© Cambridge University Press 2013

This publication is in copyright. Subject to statutory exception
and to the provisions of relevant collective licensing agreements,
no reproduction of any part may take place without the written
permission of Cambridge University Press.

First published 2013

ISBN 978-1-107-25675-0

Editor: Fairuz Parker

Proofreader: Cheryl Knupp

Typesetter: Simon van Gend

Illustrators: Sara Jardine, Naeem Mohamed, Zedduo

Cover image: *Panthera pardus*, commonly known as a Leopard, © Doug Steakley/Gallo Images
/Getty Images

.....
Cambridge University Press has no responsibility for the persistence or
accuracy of URLs for external or third-party internet websites referred to in
this publication, and does not guarantee that any content on such websites is,
or will remain, accurate or appropriate. Information regarding prices, travel
timetables and other factual information given in this work are correct at
the time of first printing but Cambridge University Press does not guarantee
the accuracy of such information thereafter.
.....

NOTICE TO TEACHERS

The photocopy masters in this publication may be photocopied or
distributed [electronically] free of charge for classroom use within the
school or institution which purchases the publication. Worksheets and
copies of them remain in the copyright of Cambridge University Press
and such copies may not be distributed or used in any way outside the
purchasing institution.

Acknowledgements

AAI/Fotostock SA: bowl/cup/plate p E40 and E41, yoghurt p E40 and E41, blood bags p E40
and E41, water bottles p E40 and E41; **Bigstock:** plastic bottles p E40 and E41, plastic gloves
p E40 and E41; **Fairuz Parker:** detergent bottles p E43 and E46, plastic containers p E43 and
E46, egg box p E43 and E46, plastic toys p E43, blister plastic p E43 and E46.

If you want to know more about this book or any other Cambridge University Press
publication, phone us at +27 21 4127800, fax us at +27 21 419-8418 or send an e-mail to
capetown@cambridge.org

Contents

Expanded contents pages	iv
Section A: Introduction	A1
Section B: Planning	B1
Section C: Assessment	C1
Section D: Teaching guidelines	D1
Section E: Photocopiable resources	E1
Section F: Documents	F1

Term	Strand	Module	Unit	Time allocation (weeks and hours)	Lesson	Activities	CAPs content, concepts and skills	Assessment tasks	LB page	TF page				
Term 1	Structures	1. Structures	1.1 Graphic communication	Week 1 (2 hrs)	Lesson 1	Activity 1 Activity 2 Activity 3	First angle orthographic projection, three different views	Drawing	5	D3 D3 D4				
					Lesson 2	Activity 4 Activity 5	Discuss line types, scale and dimensions	Scaled 3D drawing	9 11	D4 D4				
					Lessons 3 and 4	Activity 6 Activity 7	More complex 3D objects in orthographic projection with instruments Flight of stairs and wheel ramp in 3D using isometric projection Design brief Plan of stair and ramp first angle projection with scale, correct views, line types, dimensions	Drawing	12 13	D4 D5				
					Lesson 5	Activity 8 Activity 9 Activity 10	Forces can be dynamic or static Loads can be even or uneven Strength of materials under tension, compression, both, torsion	Solving problems answering questions Self assessment	17 17 18	D5 D6 D6				
					Lesson 6	Activity 11 Activity 12 Activity 13	Properties of materials Find the strongest design Assessment informal: Analysing for tension, compression, torsion Learning about materials and their properties Homework worksheet, materials, properties	Teacher assesses Group work Class discussion Teacher assesses	23 27 29	D7 D7 D8				
					Formal Assessment Task: Mini-PAT 1									

Term	Strand	Module	Unit	Time allocation (weeks and hours)	Lesson	Activities	CAPs content, concepts and skills	Assessment tasks	LB page	TF page				
1	Structures	1. Structures	1.2 Structures: Forces, strength and properties	Week 4 (2 hrs) Week 4	Lesson 7	Activity 14	Discussion of scenario and possible solutions Identification of roles in the group Teacher explains plan process, business using hand out Drawing up a business plan Answering an advert	Teacher assesses plan Peer	35	D9				
					Lesson 8	Activity 15	Tendering process Listing of tasks for each role discussion of factors influencing the solution of the problem	Teacher/ Project Manager Teacher	36	D10				
					Lesson 9	Activity 16 Activity 17	Creation of ideas out of knowledge of structures Sketches of two solutions Look at sketches to evaluate and adapt	Evaluation, adaption Teacher	41 43	D15 D15				
					Lesson 10	Activity 18 Activity 19	Design brief and specifications requirements Flow chart requirements	Design Brief and specifica- tions Flow chart	43 43	D15 D16				
					Lesson 11	Activity 20	Working drawings	Drawing first angle orthographic projection	43	D16				
					Lesson 12	Activity 21	Budgets	Costing of materials, labour, overhead costs	45	D16				
					Lesson 13 and 14	Activity 22	Making, working with tools, materials following order of work Safe working practices Working as a team	Building the model	45	D16				
					Week 6 (2 hrs) Week 6									
					Week 7 (2 hrs)									

Term	Strand	Module	Unit	Time allocation (weeks and hours)	Lesson	Activities	CAPs content, concepts and skills	Assessment tasks	LB page	TF page
1	Structures	1. Structures	1.2 Forces, strength and properties	Week 8 (2 hrs)	Lessons 15 and 16	Activity 23	Knowledge of a rubric design Evaluation skills	Design a rubric Evaluation of own project and other teams with RUBRIC	46	D17
				Week 9 (2 hrs)	Lessons 17 and 18	Activity 24	Knowledge of each member's role Understanding of structures Understanding of drawings, artistic and working	presentation of project to tender board	47	D17
				Week 10			Formal assessment			
Term 2										
2	Mechanical systems and control	2: Mechanical systems and control	2.1 Hydraulics and pneumatics	1 (2 hrs)	Lesson 1	Activity 1 Activity 2	Investigate a hydraulic and pneumatic system using two equal sized syringes Self-assessment	Revision Experiments Recording Worksheets	53 55	D23 D25
					Lesson 2	Activity 3	Investigate a hydraulic and pneumatic system using two different sized syringe	Worksheets Observation Discussion	55	D26
					Lesson 3	Activity 4 Activity 5	Construct a simple hydraulic system Hydraulics	Research Observation Investigation Recording	58 59	D26 D28
				2 (2 hrs)	Lesson 4	Activity 6 Activity 7 Activity 8	How a hydraulic jack works Working the hydraulic jack	Evaluation Observation Presentations	62 63 66	D29 D29 D32
					Lesson 5	Activity 9 Activity 10	Draw a systems diagram		67 68	D33 D33
			2.2 Pulleys	3 (2 hrs)	Lesson 6	Activity 11	Investigating pulleys	Worksheets Observation Presentation	75	D34
					Lesson 7	Activity 12 Activity 13	Bicycle brake Mechanical control system	Recording Drawing	81 83	D35 D35
				4 (2 hrs)	Lesson 8	Activity 14	Design a handout	Designing a handout	86	D36

Term	Strand	Module	Unit	Time allocation (weeks and hours)	Lesson	Activities	CAPs content, concepts and skills	Assessment tasks	LB page	TF page
2	Mechanical systems and control	2: Mechanical systems and control	2.2 Pulleys		Lesson 9	Activity 15	Gears	Designing a handout	89	D37
					Lesson 10	Activity 16	Evaluation skills and design skills	Investigation Worksheet	90	D38
					Lesson 11	Activity 17 Activity 18	Draw a 3D wooden object using single VP perspective Use single VP perspective to draw an inside view of the classroom	Drawing texturing	91 93	D39 D40
						Formal Assessment Task: Mini-PAT 2				
					Lesson 12	Activity 19	Investigation skills	Investigation Discussion recording	95	D42
					Lesson 13	Activity 20	Design skills - sketches	Sketching	95	D43
					Lesson 14	Activity 21	Working drawings	Drawing	97	D43
					Lesson 15 and 16	Activity 22	Make: Prototype working model	Making Building	97	D44
					Lesson 17	Activity 23	Communication skills	Presentations Project portfolio	97	D44
							Formal Assessment			

Term	Strand	Module	Unit	Time allocation (weeks and hours)	Lesson	Enabling tasks	CAPs Content, concepts and skills	Assessment tasks	LB page	TF page															
Term 3	Electrical systems and control	3. Electrical systems and control	3.1 Revision: Component symbols	Week 1 (2 hrs)	Lesson 1	Activity 1 Activity 2 Activity 3 Activity 4 Activity 5 Activity 6 Activity 7 Activity 8 Activity 9 Activity 10 Activity 11 Activity 12	Revision Component symbols Simple circuits Ohm's Law qualitatively	Revision Observation Component symbols Making simple circuits Ohm's law	100 101 102 103 104 104 105 105 106 106 108	D47 D48 D48 D48 D49 D49 D51 D51 D53 D53 D54 D54															
											3.2 Revision: Simple circuits 3.3 Ohms law quantitatively 3.4 Testing Ohm's law	Lesson 2	Activity 13 Activity 14 Activity 15	Research: Testing Ohm's law Reading on graph Calculate values	Research Measuring Plotting on graph Readings	109 111 112	D55 D55 D56								
																		3.5 Resistors	Lesson 3	Activity 16	Resistor colour codes Low value resistors High value resistors	Investigating resistor colour codes	116	D57	
																									Lesson 4
																			3.6 Components	Lesson 5	Activity 19 Activity 20	Switches: Manual switches Diodes and LED	Types of switches, Diodes and LED Knowledge of transistors	121 122	D59 D59
																				Lesson 6	Activity 21	Transistors Connect a simple transistor circuit	Building circuits	124	D59
																			Week 4 (2 hrs)	Lesson 7	Activity 22	Sensors - input devices Light dependent resistor - LDR	Knowledge of sensors Observation	125	D60

Term	Strand	Module	Unit	Time allocation (weeks and hours)	Lesson	Enabling tasks	CAPs Content, concepts and skills	Assessment tasks	LB page	TF page
3	Electrical systems and control	Electrical or electronic systems	3.6 Components		Lesson 8	Activity 23 Activity 24 Activity 25 Activity 26 Activity 27 Activity 28	Thermistor, touch or moisture detector, capacitors	Observation	126 126 127 127 128 128	D60 D60 D60 D61 D61 D61
					Lesson 9	Activity 29	Simple electronic circuits <ul style="list-style-type: none"> LED, 470 ohm resistor, switch, and 4,5 V series battery LDR, buzzer, 3 V series battery 	Draw Make simple circuits	129	D62
			Lesson 10		Simple electronic circuits <ul style="list-style-type: none"> NPN transistor, buzzer or bell, thermistors, variable resistor, 1k ohm resistor, 6 V series battery (or DC power supply or photovoltaic panel) 6 V series battery, LED 470 ohm resistor, 1000 uF capacitor switch 	Draw Group work Assemble electronic circuits	131	D63		
			Lesson 11	Activity 30	Choose appropriate circuit to solve the problem, need or want given in the scenario. Incorporate into the design	Investigate Design	134	D64		
			3.7 Simple electronic circuits	Week 5 (2 hrs)		Short Practical Assessment Task: Mini-PAT 3			131	D63
				Week 6 (2 hrs)						

Term	Strand	Module	Unit	Time allocation (weeks and hours)	Lesson	Enabling tasks	CAPs Content, concepts and skills	Assessment tasks	LB page	TF page			
3	Electrical systems and control	Electrical or electronic systems	3.7 Simple electronic circuits		Lesson 12	Activity 31	The design brief. Individual drawing of circuit diagram Sketch in 3D showing the device that will use the electronic circuit. Final solution.	Design Circuit diagram 3D sketch Suggest final solution	135	D65			
					Lesson 13	Activity 32	Plan for their device/model/prototype Each team member draws a working drawing	Working drawings first angle orthographic projection 3D exploded view	136	D65			
					Lesson 14	Activity 33	Device/prototype/working model Showcase a viable solution Scale and net Show intelligent use of available materials	Make model	137	D66			
					Lessons 15 and 16	Activity 34	Present their solution: sketches, artistic impressions, working drawings/plans, costing, and their model	Team presentations	137	D66			
					Lessons 17 and 18	Activity 35	Each learner compiles a record of his/her own individual contribution to the task	Record of contributions	138	D67			
					Week 7 (2 hrs)								
					Week 8 (2 hrs)								
					Week 9 (2hrs)								
					Week 10 (1 hr)						Summative assessment		

Term	Strand	Module	Unit	Time allocation (weeks and hours)	Lesson	Activities	CAPs Content, concepts and skills	Assessment tasks	LB page	TF page	
Term 4	Processing	4. Processing	4.1 Preserving metals	1 (2 hrs)	Lesson 1	Activity 1 Activity 2	Preserving metals -Theory Painting Galvanising	Informal, observation and correction of task	147 148	D69 D71	
					Lesson 2	Activity 3	Preserving metals - Practical Electroplating	Teacher assessment of electroplating task	148	D71	
				2 (2 hrs)	Lesson 3	Activity 4 Activity 5 Activity 6	Preserving food - Theory Storing grain Pickling	Correction of written task	151 152 154	D72 D72 D73	
			Lesson 4		Activity 7 Activity 8	Preserving food - Practical Drying and/or salting	Demonstration of drying or salting to preserve food	154 155	D73 D73		
			3 (2 hrs)	4.3 Processing plastic	Lesson 5	Activity 9 Activity 10	Types of plastic and their uses Investigation: Identification of plastic identifying codes and sorting for recycling	Tabulation of information	156 157	D74 D74	
						Lesson 6	Activity 11	Properties of plastics Reduce -reuse - recycle	Informal, observation and correction of written activity	159	D74
					Lesson 7	Activity 12	Case study 1: Remanufacturing waste plastic into pellets for re-use Systems diagram: Draw a systems diagram describing a plastics recycling plant	Discussion Drawing a systems diagram	165	D75	
			5 (2 hrs)	4.4 Re-use of waste plastic	Lesson 8	Activity 13 Activity 14 Activity 15	Case study 2: Moulding recycled plastic pellets into products	Informal, observation and correction of written task	165 167 167	D76 D77 D77	
						Lesson 9	Formal Assessment Task: Mini-PAT 4	Case study 3: Plastics used in modern motor cars.	Tabulation of information Paragraph writing	168	D78

Term	Strand	Module	Unit	Time allocation (weeks and hours)	Lesson	Activities	CAPs Content, concepts and skills	Assessment tasks	LB page	TF page
4	Processing	4. Processing	4.4 Re-use of waste plastic		Lesson 10	Activity 16 Activity 17 Activity 18 Activity 19	Case study 4: Plastics around the home Problem identification: Identify a need or want that can be satisfied by the making of a plastic item of their own design	Discussion Identification of a problem Recording of information	173 173 174 175	D78 D78 D79 D79
					Lesson 11	Activity 20 Activity 21	Sketch: sketch their plastic item using isometric projection on grid paper Plan: draw their plastic item using first angle orthographic projection	Communication Isometric and first angle projection drawings	176 178	D80 D80
					Lesson 12	Activity 22	Skills development: practise the skills needed to manufacture their plastic item – measure, mark out, cut, bend and join. Moulding is an optional extra	Making Informal assessment - observation of skills	179	D80
					Lesson 13	Activity 23 Activity 24	Practical sessions: Working safely, learners measure, mark out, cut and bend the materials for their plastic item and then assemble the product	Making Demonstration of team work and making skills Teacher assessment	180 180	D81 D81
				Lesson 14	Activity 25	Each learner compiles a record of his/her term's work including extending the life span of metals and food, properties and uses of various plastics, the plastic recycling strategy, the case studies and the sketches and plans for the product.	Communication skills Teacher's assessment of product and portfolio	180	D81	
				8 (2 hrs)			Summative year end examinations	Formal assessment task under exam conditions		

Section A: Introduction



Curriculum and Assessment Policy Statement (CAPS)	A3
Inclusivity	A6
Time allocation per subject	A10
Technology in the school curriculum	A10
Requirements for Technology	A15

Welcome to **Technology Grade 9**. This course includes a Learner's Book and Teacher's Guide that provide the core material you need to cover the content required by the Curriculum and Assessment Policy Statement for Grade 9 Technology.

In the Introduction (Section A) you will find information about the core features of the National Curriculum and detailed advice on the Technology subject in particular.

Assessment is covered in Section C and explains how and when assessments should be done.

Section B (Planning) contains a detailed phase plan, teacher plan (work schedule) and an exemplar of a lesson plan. The answers to all activities can be found in Section D. These include rubrics and checklists for formal and informal assessment of prescribed practical work.

Section E contains photocopiable worksheets, activities, rubrics and exemplar assessments. In Section F you can file your copy of the Curriculum and Assessment Policy Statement. You can also file your own documents in this section.

As a teacher at the General Education and Training (GET) level, your two main resources are:

- your expertise in the subject
- your teaching experience – knowing how to help learners master the skills and knowledge of this subject.

Curriculum and Assessment Policy Statement (CAPS)

The new Curriculum and Assessment Policy Statement (CAPS) makes two core demands on you as the teacher:

- to follow a learning programme that enables learners to develop all the skills, knowledge, values and attitudes relevant to Technology
- to have a sound, up-to-date knowledge of the content and methods of your subject, and a clear understanding of its social relevance, so that you can act as a guide, facilitator and subject expert in the classroom.

This textbook helps you to meet these demands in the following ways:

- it provides a structure for your teaching programme for the year and a teaching plan (work schedule) that is in line with the CAPS requirements
- it provides solutions to all the activities in the Learner's Book
- it explains all the assessment requirements of the curriculum and provides practical activities with their rubrics and checklists that are required by CAPS
- it contains examples of generic rubrics, checklists and assessment sheets that you can use or adapt for your assessment work throughout the year.

General aims of the South African Curriculum

The National Curriculum Statement Grades R to 12 gives expression to knowledge, skills and values that are regarded to be worth learning. This statement will ensure that learners acquire and apply knowledge and skills in ways that are meaningful to their own lives. In this regard, the curriculum promotes the idea of grounding knowledge in local context, while being sensitive to global imperatives.

The purpose of the National Curriculum Statement Grades R to 12

The National Curriculum Statement aims to:

- equip learners, irrespective of their socio-economic background, race, gender, physical ability or intellectual ability, with the knowledge, skills and values necessary for self-fulfilment and meaningful participation in society as citizens of a free country
- provide access to FET and higher education.

The principles of the National Curriculum Statement Grades R to 12

The principles of the National Curriculum Statement are:

- social transformation
- active and critical learning
- high knowledge and high skills
- progression
- human rights, inclusivity, environmental and social justice
- valuing indigenous knowledge systems
- credibility, quality and efficiency.

These principles can be applied to your school context in the following way:

Social transformation

What does social transformation mean in your classroom? Your learners will come from families and communities that have been affected in diverse ways by South Africa's past. They will have many different ideas about the kind of future career they want and the kind of society they want to live in. In the learning programme that you plan for the year, you need to provide opportunities for the learners to analyse, research and come to understand the role that this particular subject plays in shaping the kind of society we want to create in South Africa and in offering them possibilities for their future.

For example: Create opportunities for learners to research and discuss questions such as how many people in their families have studied Technology and to what levels. How does access to Technology education relate to access to different kinds of employment? What factors influence people's access to and success in the subject?

Active and critical learning

What does this mean in your classroom? Many of the laws and principles in Technology have been developed and formulated over centuries.

You need to explain the background of how these laws and principles were developed and the meaning and application of their formulation. Make the learners aware that technological knowledge is man-made solutions or ideas to solve problems.

For example: Ways of processing food is to make food last longer and can change as new technologies become available.

High knowledge and high skills

What does this mean in your classroom? You, as a subject expert, should inspire your learners with relevant knowledge and activities that will encourage them to want to explore technology in depth. Encourage them to relate what they learn to their lives outside school and to possible future career paths. Strive to develop a high level of knowledge and skills in this subject in all your learners.

For example: Relate the study of particular Technology topics to future career paths, such as electrical, chemical and mechanical engineering and electrical and telecommunications technology. Where possible, create opportunities for learners to meet professional practitioners in these and other relevant fields. Set projects that challenge learners to apply their technology skills outside the school context. Inform them about what they can expect to learn if they follow these subjects in the FET and later on enrol for higher education in related technology subjects.

Progression

What should this mean in your classroom? This Technology curriculum contains material at the appropriate level to meet the criteria required for Grade 9. If you plan a learning programme using this curriculum, you will ensure that your learners progress appropriately through the levels of knowledge and skills that the curriculum requires.

Human rights, inclusivity, environmental and social justice

What should this mean in your classroom? In all activities that you organise and facilitate, create opportunities to relate Technology to the broader social goal of promoting human rights, environmental justice and social justice. Take into account that some of your learners might grapple with issues such as poverty, language and disability in their daily lives. Encourage them to explore these issues in ways that relate to this subject.

For example: Identify a social issue of relevance in the learners' community and help them research and design a technology solution to a community problem. This could relate to the availability of a bridge to cross a river or to design a two-way switch for a gate or a light in a passage.

Valuing indigenous knowledge systems

What should this mean in your classroom? This Technology curriculum contains material that draws on indigenous knowledge systems and encourages learners to take these systems into account in their research and practical work. You should also draw on the expertise in your subject that may be available in your local community. Compile information about individuals and organisations in your region that can support your classroom work by means of relevant indigenous knowledge to which they have access.

Encourage learners to recognise sources of relevant indigenous knowledge in their own communities, and to include these sources in their research and practical work.

For example: People from indigenous cultures have always found ways to preserve food.

Credibility, quality and efficiency

What should this mean in your classroom? The content of the Technology curriculum has been reviewed by experts in their fields of civil, electrical and mechanical engineering and covers all facets required to prepare learners to go on to FET.

Qualities and skills of learners

The National Curriculum Statement aims to produce learners who are able to:

- identify and solve problems and make decisions using critical and creative thinking
- work effectively as individuals and with others as members of a team
- organise and manage themselves and their activities responsibly and effectively
- collect, analyse, organise and critically evaluate information
- communicate effectively using visual, symbolic and/or language skills in various modes
- use science and technology effectively and critically, showing responsibility towards the environment and the health of others
- demonstrate an understanding of the world as a set of related systems by recognising that problem-solving contexts do not exist in isolation.

Inclusivity

Inclusivity should become a central part of the organisation, planning and teaching at each school. This can only happen if all teachers have a sound understanding of how to recognise and address barriers to learning and how to plan for diversity. We have included some guidelines on how teachers can achieve this.

Inclusive education and training should:

- acknowledge that all children and youth can learn, and that all children and youth need support
- accept and respect the fact that all learners are different and have different learning needs, which are equally valued
- enable education structures, systems and learning methodologies to meet the needs of the learner
- acknowledge and respect differences in children, whether due to age, gender, ethnicity, language, class, disability, HIV status or any other reason.
- maximise the participation of all learners in the culture and the curriculum of educational institutions and uncover and minimise barriers to learning.

What should this mean in your classroom? In this series of books, the learners work together in groups and pairs, which gives them the opportunity to learn from each other, as well as at their own pace. The learning methodologies cater for learners with different learning abilities. Gender is also addressed as both boys and girls are able to participate in all the activities. Learners also have the opportunity to learn about diversity within the subject matter covered.

Learners with physical barriers can work in groups or with a partner so they can be assisted where necessary. The teacher must therefore group learners with disabilities together with learners with other disabilities or no disabilities so they can support each other.

Special needs

In many classrooms, learners with special needs require additional attention. Some learners require very little attention while others need more extensive help. As a teacher, be especially sensitive towards these learners without drawing too much attention to the learners' possible barriers to learning.

Discretely make their fellow learners aware of the need to treat each other with respect without exception. This vital life skill should be engrained in all young people so that it becomes part of their personalities for the rest of their lives. The information that follows will assist you in addressing some of these special needs in your classroom in an inclusive way. Be aware of these and other special needs of learners in your classroom.

Partial sight or blindness: For partially sighted learners who find it difficult to read text, you could enlarge the text by using a photocopy machine. Also, ensure that these learners sit in the middle or at the front of the class so that their poor eyesight does not become a barrier to their learning.

Alternatively – and especially in group work – read the text aloud to these learners. Remind the learners to read loudly, clearly and slowly as partially sighted and blind learners rely heavily on their

memories. When doing experiments, these learners might not be able to see results. Train a few fellow learners with excellent social skills to convey results to their peers.

It is also a good idea to let these learners stay in the groups with learners you have trained specially to help them.

Hard of hearing: Once again, these learners should sit in the front of the class. When giving instructions, or when reading text to these learners, the speaker or reader should face the learner directly and speak loudly and clearly but without exaggerating. Learners who are hard of hearing learn to lip-read very early in life.

Impaired social skills: The nature of these difficulties varies, but could, in some cases, become a serious barrier to learning.

- Learners who are very shy or highly-strung might find class presentation extremely stressful. Although you should encourage them to develop this life skill, remember that you can never change someone's nature completely. Work gently with these learners – their shyness or nervousness may be the result of negative circumstances at home. Let them present their class presentations in written form at first, and then move slowly as the year progresses, at first letting them present their work to one classmate only, then to a small group, and finally to the whole class.
- Children with ADS (Attention Deficit Syndrome, also known as ADD Attention Deficit Disorder) will find it extremely difficult to work in groups or to sit still and concentrate for very long – in some cases having to listen for two minutes is too long. Learners with ADS could affect the class atmosphere and class discipline in a negative way, and although everyone will agree that the deficiency is no fault of their own, they should not be allowed to ruin their fellow learners' education.

The school should have a policy that parents must inform the school confidentially if their child suffers from ADS. If learners have been diagnosed, they could be on medication. It is essential that teachers are informed; otherwise the learner could be branded as 'extremely naughty', which would be unfair and result in inappropriate handling. Teachers should be very careful not to judge a 'naughty' learner too soon. ADS is quite common, and in some cases may not have been diagnosed.

Look out for a learner who:

- finds it difficult or even impossible to concentrate
- frequently interrupts the teacher with irrelevant or seemingly ‘stupid’ questions
- fidgets all the time to the point of irritating peers
- jumps up frequently and asks to go to the bathroom (or somewhere else) at inappropriate times
- shouts out answers or remarks when the class has been asked to put up their hands
- is unable to deal with group work or pair sessions – these periods are interpreted as a ‘free for all’
- shows signs of aggression when fairly disciplined
- argues with the teacher when asked to keep quiet.

Please note that:

- the disorder is more prolific among boys than among girls
- diet could play role in controlling the disorder – fast foods and junk foods should be kept to a minimum.

Extreme poverty: This barrier to learning requires extreme sensitivity from the teacher. If you know that there are one or more learners in your class who come from poverty-stricken backgrounds, you could handle the situation as follows:

Learners are often required to bring resources from home, especially in practical learning areas like Technology. Some learners may be unable to afford additional resource materials such as magazines for research, rulers, calculators and mathematical sets. Keep a supply of these items in your classroom without informing your learners and unobtrusively give them to those learners you know have difficulty in acquiring them. Be careful not to encourage ‘forgetters’ to make use of this offer! You could ask community groups in your area, such as churches, to provide support in collecting supplies of materials for you to keep in your classroom.

The key to managing inclusivity is ensuring that barriers are identified and addressed by all the relevant support structures within the school community, including teachers, district-based support teams, institutional-level support teams, parents and special schools as resource centres. To address barriers in the classroom, teachers should use various curriculum differentiation strategies such as those included in the Department of Basic Education’s *Guidelines for Inclusive Teaching and Learning* (2010).

Time allocation per subject

The instructional time in Grade 9 is shown in the table:

SUBJECT	HOURS
Home Language	5
First Additional Language	4
Mathematics	4,5
Natural Sciences	3
Social Sciences	3
Technology	2
Economic Management Science	2
Life Orientation	2
Arts and Culture	2
TOTAL	27,5

The allocated time per week may only be used for the minimum required NCS subjects as specified above. Should a learner wish to take additional subjects, these will have to be done outside this time.

Technology in the school curriculum

Purpose

Technology education was introduced into the South African curriculum in recognition of the need to produce engineers, technicians and artisans needed in modern society and the need to develop a technologically literate population for the modern world. The subject stimulates learners to be innovative and develops their creative and critical thinking skills. It teaches them to manage time and material resources effectively, provides opportunities for collaborative learning and nurtures teamwork. These skills provide a solid foundation for several FET subjects as well as for the world of work.

In the educational context, Technology can be defined as:
The use of knowledge, skills, values and resources to meet people's needs and wants by developing practical solutions to problems, taking social and environmental factors into consideration.

Specific aims

Technology as a subject contributes towards learners' technological literacy by giving them opportunities to:

- develop and apply specific design skills to solve technological problems
- understand the concepts and knowledge used in Technology education and uses them responsibly and purposefully
- appreciate the interaction between people's values and attitudes, technology, society and the environment.

The intention is to **introduce** learners to the **basics** needed in Civil Technology, Mechanical Technology, Electrical Technology and Engineering Graphics and Design. Additionally, learners gain an idea of the way engineers apply scientific principles to practical problems. In addition, **evaluation** skills will be fostered and the introduction of product **design** and **production** will be useful in other FET subjects that use these skills – such as Consumer Studies and Design. It is expected that Technology education will provide learners with some experience to help them to make career-oriented **subject choices** at the end of Grade 9.

Unique features and scope

Key issues to teach:

1. Problem solving using the design process
2. Practical skills
3. Knowledge and application of knowledge.

Technology will give learners the opportunity to learn:

- to solve problems in creative ways
- to use authentic contexts rooted in real situations outside the classroom
- to combine thinking and doing in a way that links abstract concepts to concrete understanding
- to evaluate existing products and processes, and to evaluate their own products
- to use and engage with knowledge in a purposeful way
- to deal with inclusivity, human rights, social and environmental issues in their tasks
- to use a variety of life skills in authentic contexts (such as decision making, critical and creative thinking, co-operation, problem solving and needs identification)
- to work collaboratively with others through practical projects, using a variety of technological skills (investigating, designing, making, evaluating and communicating) that suit different learning styles.

At the same time, learners will be creating positive attitudes, perceptions and aspirations towards technology-based careers.

Topics and core content areas in Technology

The table below indicates the main focus areas in the Technology curriculum:

1.	The design process skills (non-linear) <ul style="list-style-type: none"> • Investigation skills • Design skills • Making skills • Evaluation skills • Communication skills
2.	Structures
3.	Processing of materials
4.	Mechanical systems and control
5.	Electrical systems and control
6.	Technology, society and the environment <ul style="list-style-type: none"> • Indigenous technology • Impact of technology • Bias in technology

There are four core content areas in Technology in Grades 7–9. These are:

Structures	Processing	Mechanical systems and control	Electrical systems and control
------------	------------	--------------------------------	--------------------------------

NB: All electric circuits must be battery powered in the GET Band - Max 9V DC

These four content areas form the basis of the four strands that must be done each year in every grade. Where possible in the senior phase, the learner should engage in projects that integrate processing, structures and systems and control. The recommended approach will be to introduce the required knowledge followed by practical work in which the knowledge is applied. In all cases, the teaching will be structured using the design process as the backbone for the methodology. Some of these elements will be assessed formally each term. As learning progresses, learners must be made aware of the interrelationship between technology, society and the environment. Wherever applicable, learners should be made aware of different coexisting knowledge systems. They should learn how indigenous cultures have used specific materials and processes to satisfy needs, and become aware of indigenous intellectual property rights. Learners should be able to consider the impact of technology, both positive and negative, on people's lives. Learners should be made aware of bias in technology and be able to express opinions that explain how certain groups within society might be favoured or disadvantaged by products of technology.

The importance of design in Technology education

No product has ever been manufactured that did not undergo development through design. Technology education is an introduction to a range of careers that work in similar ways. All tend to use the

design process as they develop solutions to problems, needs or wants. The country needs informed, critical consumers and producers of knowledge.

A key element to teach is the ability to design.

With many similar products on the market, design excellence is a key element in attracting consumers.

Examples of careers that use design:

Civil engineering - designing a bridge Architecture - designing a house Textile design - developing a textile for a specific purpose Electrician - designing the electrical wiring for a lamp	Dietician - designing a diet to combat malnutrition and obesity Mechanical engineering - designing a support system for the roof of a stadium
--	--

Designers need to have...

- an understanding of the problem, need or opportunity
- knowledge of the design process
- knowledge of types and properties of suitable materials, and how to use them optimally
- the ability to calculate the quantities and costs of the materials needed
- knowledge of the conventions/building codes
- an ability to sketch initial ideas on paper
- the ability to draw working drawings in sufficient detail for the task
- the practical skills required to create a solution
- the ability to work safely using appropriate tools
- the ability to adhere to health precautions
- the ability to present the solution effectively to the client/customer.

Teaching methodology (how tasks will be approached)

As learners progress through a task, they must be taught the associated knowledge and skills needed to design and create a solution.

Knowledge is important BUT the learners must show that they can use the knowledge, and not just memorise it.

The design process (Investigate, Design, Make, Evaluate, Communicate – IDMEC) forms the backbone of the subject and should be used to structure the delivery of all learning aims. Learners should be exposed to a problem, need or opportunity as a starting point. They should then engage in a systematic process that allows them to develop solutions that solve problems, rectify design issues and satisfy needs.

Investigate

Investigation in this subject involves finding out about contexts and needs, investigating or evaluating existing products in relation to key

design aspects and performing practical tests to develop understanding of particular aspects of the content areas or determining a product's fitness-for-purpose. While investigating, learners should be provided with opportunities to explore values and attitudes and develop informed opinions that can help them to make compromises and value judgements. Investigation can happen at any point in the design process. It should not be seen as something that must be completed before design begins.

Designing, making and evaluating.

These skills should not be seen as separate – they are inter-related.

Evaluation skills, for example, are used to choose ideas. At this level, learners should be introduced to key aspects of design. These should be used to evaluate both existing and designed products against predetermined criteria.

When making, learners should be encouraged to continue to reflect on their progress against these criteria and to modify their solutions based on problems encountered.

As learners progress they should be able to demonstrate increasing accuracy and skill, better organisation and safer working practices.

Criteria for teaching and assessing design features:

- originality and aesthetics
- value for money/cost effectiveness
- fit-for-purpose and suitability of materials
- ease of manufacture
- safety and ergonomics
- environmental impact
- bias towards or against a group.

Communication

Communication should also be seen as integral to the overall process. Learners should be recording and presenting progress in written and graphical forms on an on-going basis. Their presentations should show increasing use of media, levels of formality and conventions as they progress through the phase.

Technology develops valuable problem-solving skills that will benefit every learner in many life contexts.

Note on drawing: The Grade 9 learner must be able to identify and explain a problem, need or opportunity from a given real-life context.

In Grades 7–9 Technology, drawing is separated into three fields:

- free-hand sketches in the design stage
- working drawings in the making stage, using formal draughting techniques in line with conventions
- artistic impressions in the communication stage, using artistic techniques including perspective, texture rendering, shading,

colours and shadows in order to advertise the product to potential users.

NB: Perspective drawing here is purely artistic and has no link to the method of linking the perspective to the working drawing using formal construction lines. In Technology, learners draw both technical AND artistic graphics.

Time allocation for Technology

The teaching time for Technology is two (2) hours per week. As this subject involves practical work, 60 minutes of the two hours should be one continuous period for practical work, e.g. one double period comprising two periods of 30 minutes.

Schools using alternative period lengths, or a cycle system, must ensure that all subjects get their correct time allocation and that sufficient time is allocated for practical sessions.

Requirements for Technology

1. Each learner must have:
 - an approved textbook
 - a 72-page A4 workbook/exercise book (In secondary schools learners may require two books per year.)
 - stationery, including a basic mathematical set (drawing instruments), pencil, eraser, ruler and set squares
2. There must be a designated teaching venue with a Technology teacher.
3. Technology rooms must be secure, with doors that lock, and with burglar-proofing if possible. Enough cupboards should be available to store and lock away all resources.
4. It is the responsibility of the school to provide each learner with the minimum tools and material to meet the needs of the subject (see Section D for possible tools and resources) and to develop the teacher's appropriate knowledge and skills.
5. **Enabling tasks:** Activities used to teach and then practise specific skills in preparation for a more advanced task – sometimes also called resource tasks. These tasks are assessed informally.
6. **Mini-PAT:** A short Practical Assessment Task that makes up the main formal assessment of a learner's skills and knowledge application during each term. It may be an assignment covering aspects of the design process, or it may be a full capability task covering all aspects of the design process (IDMEC).

Note: The **curriculum for Grade 9** has been **described very specifically** to ensure that all the learners cover the same work in all schools across the country before graduating to secondary schools. Some limited variations will be developed by the various textbook authors.

The **curriculum for Grade 8** has some sections described fairly specifically while other sections give a lot of freedom for the innovation expected from textbook authors.

The **Grade 9 learners** have to be able to ‘identify a problem, need or opportunity’ in a given context. Consequently the **curriculum for Grade 9** is non-specific and textbook authors have free reign to develop ideas that suit the **given content**.

Section B: Planning



Teacher plan

B3

Lesson preparation

B3

Planning

Teachers are involved in different levels of planning for each subject. These different levels of planning make up the learning programme for that subject.

A learning programme consists of a subject framework, work schedules and lesson preparations.

Teacher plan (work schedule)

The teacher plan specifies the scope of learning and assessment for the three grades in a phase of the GET band. An overview of the knowledge areas and topics for Technology in the GET phase appears on pages iv–xii of this Teacher’s File.

The Curriculum and Assessment Policy Statement (CAPS) specifies the core knowledge and concepts to be covered during the GET phase, as well as the amount of time in hours and weeks to be devoted to each topic.

Lesson preparation

A lesson preparation is a more detailed plan for a particular section of work, a period of time during the year or a particular lesson. It describes what learning is going to take place, and how it will take place. In addition to the information in the work schedule, it explains how the activities and assessments will take place as well as the use of resources. The lesson preparation also refers to prior and future learning.

You will need to carry out your own lesson preparation for your class.

Your lesson preparation will indicate when and how you will introduce each activity, each section of new knowledge, each assessment activity, and so on, using and expanding the information from the work schedule. We have included a blank lesson preparation form in Section E: Photocopiable resources, and an example of a completed lesson preparation in this section, to help you with your planning.

Exemplar of Lesson Plan Grade 9

Term 3: Week 7 - Lesson 13 and 14		
Teachers name:		
Grade: 9	Time: 2 hours	Date:
Focus: Electrical Systems and Control		
<p>Content, concepts and skills: Making skills</p> <ul style="list-style-type: none"> • Plans: working drawings • The learners produce plans for their device/model/prototype using first angle orthographic projection. The plans should include a 3D 'assembly' drawing in exploded view showing how the model fits together. • Each team member draws a working drawing of the design OR an aspect of the design. • Make: device /prototype/working model • The model must showcase a viable solution to the problem. It should be to scale and neat, and show intelligent use of available materials. 		
<p>Prior knowledge:</p> <ul style="list-style-type: none"> • Investigate the situation and the nature of the need so that an appropriate circuit can be chosen to solve the problem, need or want given in the scenario. • A given circuit must be incorporated into the design of a device that will use the electronics to address the problem, need or want. <p>The design brief:</p> <ul style="list-style-type: none"> • Each learner writes his/her suggestion for the design with specifications and constraints. <p>Sketches</p> <ul style="list-style-type: none"> • Each learner draws the circuit diagram. Each learner produces a sketch in 3D showing the device that will use the electronic circuit . • Teams meet and examine the individual suggestions to decide on a final solution. 	<p>Next week: Communication skills</p> <ul style="list-style-type: none"> • Team presentations: Each team is given five minutes to present their solution in the form of sketches, artistic impressions of the solution, working drawings/plans, costing and their model. 	
<p>Teacher's activities: Learners need to use their prior knowledge to sketch, design and produce the product. Refer back to first angle orthographic projection to sketch their plans. Assist learners that do not have the necessary skills yet. Plans should include a 3D 'assembly' drawing. Learners can share the different parts of the working drawing. Learners make the device/prototype/working model The model must showcase a viable solution to the problem. It should be to scale and neat, and show intelligent use of available materials.</p>	<p>Learners' activities: Activity 26 Activity 27</p>	
<p>Resources: (Resources will differ according to the Mini-Pat learners is going to do. The textbook will give you the resources required.)</p>		
<p>Planned assessment: (In this term the learners need to do a full project portfolio, so all aspects of the Mini-PAT will be formally assessed. Look in the Teacher's File for assessment tools.)</p>		
<p>Inclusive teaching and learning: (Barriers, remedial and extension activities) Divide learners into different groups of abilities to assist each other during the Mini-PAT.</p>		
<p>Teacher reflection:</p>		

Exemplar of recording sheet

Note different methods to calculate the 40% SBA (final assessment).

Grade Class	Term 1			Term 2 Examination			Term 3		Term 4		SBA	Practical	Theory	Final
	Mini-PAT	Test 1	%	Code	Mini-PAT	Test 1	%	Code	Mini-PAT	100 %				
Maximum marks	70	30	100		70	30	100		70	100	40	20	40	100
Date														
Learner names														

Section C: Assessment



Informal or daily assessment	C3
Using group and pair work	C4
Formal assessment	C6
Assessment tools	C11
Programme of formal assessment	C12

Assessment

Assessment is a continuous planned process of identifying, gathering and interpreting information about the performance of learners, using various forms of assessment. It involves four steps:

1. generating and collecting evidence of achievement
2. evaluating this evidence
3. recording the findings
4. using this information to understand and thereby assist the learner's development in order to improve the process of learning and teaching.

Assessment should be both informal (assessment for learning) and formal (assessment of learning). In both cases regular feedback should be provided to learners to enhance the learning experience.

Assessment is a process that measures individual learners' attainment of knowledge (content, concepts and skills) in a subject by collecting, analysing and interpreting the data and information obtained from this process to:

- enable the teacher to make reliable judgements about a learner's progress
- inform learners about their strengths, weaknesses and progress
- assist teachers, parents and other stakeholders in making decisions about the learning process and the progress of the learners.

Assessment should be mapped against the content, concepts, skills and aims specified for Technology. In both informal and formal assessments it is important to ensure that in the course of a school year:

- all of the subject content is covered
- the full range of skills is included
- a variety of different forms of assessment are used.

Informal or daily assessment

Assessment for learning has the purpose of continuously collecting information on learners' achievements that can be used to improve their learning. Informal assessment is a daily monitoring of the learners' progress.

This is done through observations, discussions, practical demonstrations, learner-teacher conferences, informal classroom interactions, etc. Informal assessment may be as simple as stopping during the lesson to observe learners or to discuss with learners how learning is progressing. Use informal assessment to provide feedback to the learners and to inform planning for teaching. Do not view informal assessment as separate from learning activities taking place in the classroom. The results of the informal daily assessment tasks are not formally recorded unless the teacher wishes to do so. Learners or teachers can mark informal assessment tasks. Self-assessment and peer assessment actively involves learners in assessment.

This is important as it allows learners to learn from and reflect on their own performance. Informal assessment also helps learners to take responsibility for their own learning and for the learning of their peers. In this way they develop a sense of self-discipline and commitment to each other's wellbeing.

The results of daily assessment tasks are not taken into account for promotional and certificate purposes. Use informal, on-going assessments to structure the acquisition of knowledge and skills and as a precursor to formal tasks in the Programme of Assessment.

Using group and pair work

Many teachers in South Africa work in overcrowded classrooms, which makes learning difficult. You can overcome some of these problems by getting a class to work in groups. Practical work is normally done in groups, while many activities lend themselves to work in pairs. Smaller groups are easier to handle and learners will also start to feel more positive about themselves.

Teamwork is an important aspect of learning skills and constructing knowledge. Sharing the workload and being aware of personal contributions to the community is important for every learner. In a group, the different roles and responsibilities people take on are essential to the success of the activity. At the GET level, learners should already become aware of the roles and responsibilities that are likely to be combined in 'professional' teams working in your particular subject areas in the real working world.

Setting up

Certain learning tasks are better approached through a whole class session; others lend themselves to group work. Working in pairs and in groups of three to six learners, learners have a chance to express themselves more often than when they are part of a class of forty or more. They learn to work in a team, helping each other freely when their knowledge or skill is strong, and being helped when it is weak. Some learners might be too shy to ask a question in front of a whole class but feel at ease asking a small group of friends.

Group work

There are many ways of organising learners into groups. Here are some ideas:

- **Language groups:** If you have learners with different home languages, you can put the speakers of each language into their own language group. Same-language groups enable all the learners to develop their understanding of a new concept in their own language. At other times you can create mixed language groups. Learners working in their second language or third language can be helped with translation and have a greater chance to contribute than they would in a large class.
- **Ability groups:** There are times when it is useful to divide learners into groups according to how well they achieve in the

learning area. The top achievers in the class are grouped together, the average learners form a group, and the slowest learners are grouped together. Top achievers can do enrichment activities while you attend to the slower learners.

- Remediation groups: When you have finished assessing some aspects of the learners' work, you may often find a few learners from different groups with the same problem. There may be a new concept they haven't quite grasped, or a few learners may have been absent at the same time while you were dealing with new work. You can then group them together temporarily while you help them sort out the problem.
- Mixed-ability groups: These groups work well on their own while you circulate between them. Vary the members of these groups so that learners have experience in working with different classmates. For instance, new groups can be formed each time a new unit of work is started.

Guidelines for using group work

- When planning group work, you should decide on the composition of each group and not always leave it to learners to cluster together with those they work with most easily.
- Divide tasks fairly among the members of each group and each member must understand his/her role.
- Give the learners clear and concise instructions.
- Define the work to be done clearly so that the group can go ahead without constantly referring to you.
- Learners must be settled and attentive when instructions are given.
- You must monitor progress at all times and should take into consideration not only the end result, but also focus attention on how the group has interacted and progressed through each step. This will be possible if you circulate amongst the groups and give information and guidance where and when it is required.
- Allow time for feedback so that learners have an opportunity to present evidence of their progress at the end of a session.
- Regular reminders of time limits and what progress should have been made at a particular stage are valuable when facilitating group work.
- Place groups as far apart as possible so that they enjoy a sense of privacy. Allow a certain amount of interaction as this often assists learners in solving problems or coping with complex areas.

Pair work

Pair work is easier to control than group work, particularly in large classes where it is difficult to re-arrange the seating. It is a very useful strategy for task-based teaching as it frees the teacher to be a facilitator, support guide and evaluator.

Pair work also allows for differentiation: pairs that work faster can be given extra tasks; some pairs can be given more challenging tasks; in mixed ability pairing, one partner can assist the other.

Solving problems related to pair and group work

- Noise can become a problem. Differentiate between ‘good learning noise’ and ‘disruptive chatter’. Firmly remind learners that they might be disturbing neighbouring classes and that they should keep their voices down.
- Certain learners dominate a group, while others are idle and not actively involved. Each individual must understand his or her role or task, which should be constantly monitored. Use the report-back to assess each learner’s involvement and progress.
- Learners may not like the partners they are paired or grouped with. There is no quick-fix solution to this problem. You must, however, use your knowledge of the learners and avoid grouping personalities or characters that are likely to clash.

Formal assessment

All assessment tasks that make up the formal programme of assessment for the year are regarded as formal assessment. Formal assessment tasks are marked and formally recorded by the teacher for progression and certification purposes. All formal assessment tasks are subject to moderation for the purpose of quality assurance and to ensure that appropriate standards are maintained.

Formal assessment provides teachers with a systematic way of evaluating how well learners are progressing in a grade and in a particular subject.

Examples of formal assessments include tests, examinations, practical tasks, projects, oral presentations, demonstrations and performances.

The formal assessment requirements for Technology are as follows:

- Formal assessment for Technology will consist of the mini-Practical Assessment Tasks and pen and paper tests or examinations.
- **At least 40 out of the 70 mini-PAT marks per term must be attributed to practical work.**
- Tasks done by learners for formal assessment purposes should be monitored by teachers at all times.
- Work done ‘off-campus’ outside the direct control of the teacher should normally not form part of the formal assessment record.
- The end of year promotion mark will comprise **40% school based assessment (SBA) and 60% (mini-PAT 20% and examination 40%) end of year examination.**

Formal Assessment in Technology - Grades 7, 8 and 9				
	INFORMAL DAILY ASSESSMENT	FORMAL ASSESSMENT : TERM MARKS		
		Practical Task and Theory Test/Examination		TOTAL
	Enabling Tasks	Mini-PAT	Term Test/Examination	Term Mark
Term 1	0%	70%	30%	100%
Term 2		70%	30%	100%
Term 3		70%	30%	100%
Term 4		70 marks = 100%	No Test	100%
Promotion Mark	CASS Component: 40%	Final Examination Component: 60%		Promotion
	Continous Assessment: Test and Mini-PATs 40	Combined Mini-PAT: 20	Examination 40	
	Term 1 + Term 2 + Term 3 + Term 4	T1 + T2 + T3 + T4		40
	10 + 10 + 10 + 10	5 + 5 + 5 + 5		

This breakdown is in line with the FET practical subjects where the PAT mark is included as part of the final examination component. In FET, the PAT mark contributes 1/3 of the final exam mark, i.e. 25 out of 75.

The above breakdown ensures that Technology in the GET band retains its focus on practical aspects. However, since GET Technology is not specialising, as happens in FET, there are four mini-PATs that need to be added together in equal portions to provide the practical examination component. As with the FET practical subjects, the combined mini-PAT marks contribute 1/3 to the final exam mark, i.e. 20 out of 60.

The forms of assessment used should vary and be age- and developmental level-appropriate. The design of these tasks should cover the content of the subject and should include a variety of tasks designed to achieve the theoretical and practical objectives of the subject.

Formal assessment tasks form part of a year-long formal Programme of Assessment in each grade and subject, and should be adapted to meet the needs of inclusivity where necessary.

Control tests and examinations

Control tests and examinations are written under controlled conditions within a specified period of time. Questions in tests and examinations should assess performance at different cognitive levels with an emphasis on process skills, critical thinking, scientific reasoning and strategies to investigate and solve problems in a variety of scientific, technological, environmental and everyday contexts. Examinations papers and control tests in Technology Grade 9 should adhere to the weighting of cognitive levels given in the table on the next page. A detailed description of the cognitive levels follows.

RECALL	UNDERSTANDING	APPLICATION	ANALYSE	SYNTHESISE	EVALUATE
ROUTINE	DIAGNOSTIC	STRATEGIC	INTERPRET	CREATE	
Low Order	Middle Order		Higher Order		
30%	40%		30%		

Mini-Practical Assessment Task (Mini-PAT)

Definition: a set of short practical assessment tasks that make up the main formal assessment of a learner’s skills and application of knowledge during each term. It may be an assignment covering aspects of the design process, or it may be a full capability task covering all aspects of the design process (IDMEC). It is composed of a variety of forms of assessment suited to the range of activities that make up a mini-PAT.

Purpose: a mini-PAT is intended to formalise the practical component of Technology contextualised within a knowledge focus. Practical activities should make up at least 40% of a Mini-PAT’s mark allocation.

- The mini-Practical Assessment Task is designed to give learners the opportunity to develop and demonstrate their levels of ability (i.e. capability) as they progress through the task’s activities.
- Each mini-PAT focuses primarily on one of the knowledge foci of Technology (viz. structures, mechanical systems and control, electrical/electronic systems and control and processing), but may be **integrated** and may target more than one knowledge focus.
- These tasks are structured according to the design process. Note that this is not a linear process happening in a fixed sequence.
- Assessment in a mini-PAT need not cover all aspects of the design process each term.
- A mini-PAT is an extended formal assessment task and must be planned with other school activities.

The Mini-PAT makes up 70% of each term’s assessment. Practical work must make up more than half of the marks.

The table below provides a guide for the mini-PAT per term per grade:

	TERM 1	TERM 2	TERM 3 Capability task	TERM 4
GRADE 7	<ul style="list-style-type: none"> • Mini-PAT: <i>Mechanical systems and control</i> Design + Make 	<ul style="list-style-type: none"> • Mini-PAT: <i>Structures</i> Investigate + Design + Make 	<ul style="list-style-type: none"> • Mini-PAT: <i>Electrical/ Structures/ Mechanisms</i> Investigate + Design + Make + Evaluate + Communicate 	<ul style="list-style-type: none"> • Mini-PAT: <i>Processing</i> Design + Make
GRADE 8	<ul style="list-style-type: none"> • Mini-PAT: <i>Structures/ Mechanical systems and control</i> Communicate + Design + Make 	<ul style="list-style-type: none"> • Mini-PAT: <i>Impact of Technology Processing</i> Investigate + Design + Make 	<ul style="list-style-type: none"> • Mini-PAT: <i>Mechanical systems and control/ Structures</i> Investigate + Design + Make + Evaluate + Communicate 	<ul style="list-style-type: none"> • Mini-PAT: <i>Electrical systems and control</i> Design + Make
GRADE 9	<ul style="list-style-type: none"> • Mini-PAT: <i>Structures</i> Communicate + Design + Make 	<ul style="list-style-type: none"> • Mini-PAT: <i>Mechanical systems and control</i> Investigate + Design + Make 	<ul style="list-style-type: none"> • Mini-PAT: <i>Mechanical systems and control</i> Investigate + Design + Make + Evaluate + Communicate 	<ul style="list-style-type: none"> • Mini-PAT: <i>Processing</i> Design + Make

- A learner must present the full design process once as a mini-Practical Assessment Task in term 3 of each grade. This meets the requirement of one project per subject per annum.
- The preferred tool to be used to assess learner performance in a mini-Practical Assessment Task is an analytical rubric.
- Teachers will assess skills and values using analytical rubrics, which should have clear descriptors for each level. This means that a descriptor should say why an achievement is deemed to be, say, 'meritorious' or 'elementary'.
- Schools must take responsibility for providing resources (both tools and materials) needed during the mini-PAT.
- Learners must complete the mini-PATs for formal assessment under teacher supervision.
- Teachers will assess the mini-PATs formally.

Tests

- A standardised test makes up 30% of each term's assessment.
- A test for formal assessment should cover a substantial amount of skills and content and should be set as follows:
 - Grade 7 – 45 minutes
 - Grades 8 and 9 – 60 minutes.
- The mark for tests is not prescribed but should be determined by the teacher taking into account the volume of the content covered and the time available. Testing in Technology will be limited to ONE test each in terms 1, 2 and 3. This may take place either just before or just after the mini-PAT, and must be planned in the school assessment programme.

Examinations

- All examinations must include questions that integrate knowledge and values with design process skills.
- In Technology the final end of year exam comprises 60% of the learners' promotion mark and should be set out as follows:

Grade	Time allocation	Mark weighting
7	60 minutes	60 marks
8	90 minutes	100 marks
9	120 minutes	120 marks

- The content assessed at the end of the year is based on the year's work as specified in the CAPS document for the grade. However, prior knowledge from a previous grade may be necessary to interpret and answer some of the questions in the higher grade.

Type of questions for pen and paper test

- The value of memorising by rote learning has little weight in a subject requiring innovation, creativity and problem-solving skills. The ability to think laterally and to develop original and appropriate solutions is a key element in learning Technology.
- Learners should be able to investigate using a variety of sources, demonstrate their ability to draw in a specific style, write a design brief, give specifications and constraints, select appropriate materials for a model, plan the sequence of manufacture of a product, evaluate a design objectively, analyse a system using systems diagrams and communicate their solutions using a range of techniques.
- Questions that integrate knowledge, skills and value have more value in Technology than a mere recall of knowledge facts.

The use of case studies

- Case studies are used to bring reality into the classroom.
- The intention should be to show learners that Technology is a subject that is close to the way the world works.
- Case studies can be used both to develop and to assess a technological skill (drawing for example), knowledge concepts and values.

Assessment tools

Checklists

Checklists consist of separate statements describing how the teacher can expect the learners to perform in a particular task. These statements are the criteria that the learners must meet to succeed.

Rubrics

Rubrics are a combination of rating codes and descriptions of standards – that is, what the learner must do, the level of competence, and so on – to be rated with a particular code. The rubric describes

the range of acceptable performance in each band of the rating scale. Rubrics require teachers to know exactly what the learner must achieve – the level of competence, and so on – to meet the particular outcome being assessed.

To design a rubric, you need to decide on the following:

- What is the outcome that you are aiming at?
- What kind of evidence should be collected?
- What are the different parts of the performance that will be assessed?
- What different assessment instruments best suit each part of the task?
- What knowledge should the learners demonstrate?
- What skills should learners apply, or what actions should they take?

It is crucial that you share the criteria in the rubric for the task with the learners before they do the required task. The rubric clarifies both what the learners should do and what they should be learning as they carry out the task. It becomes a powerful tool for self-assessment.

When the learners have completed the task and you are assessing their performance, you need to be sure that:

- each learner is assessed only once for each criterion within the rubric
- you add comprehensive comments where necessary for later moderation purposes.

Rubrics and checklists in Technology

The generic rubrics and checklists are in Section E: Photocopiable resources. Modify them for your needs and use them as a guideline to help you develop rubrics specifically for your activities and projects.

Programme of Formal Assessment

The Programme of Formal Assessment is designed to spread formal assessment tasks in all subjects in a school throughout a term and for the whole year. In addition to daily assessment (informal assessment), teachers should develop a year-long formal Programme of Assessment for Grade 9.

The learner's performance in this Programme of Formal Assessment will be used for promotion purposes to Grade 10. Assessment is school-based.

The marks achieved in each of the assessment tasks that make up the Programme of Formal Assessment must be reported to parents.

End-of-year examination

The end-of-year examination papers for Grade 9 will be internally set, marked and moderated, unless otherwise instructed by provincial Departments of Education. The internally set, marked and moderated examination will consist of two papers. The table on the next page shows the weighting of questions across cognitive levels and the specification and suggested weighting of the content for Grade 9 end-of-year examinations across two papers.

Content weighting for tests and examinations: Grades 7-9		
Investigate, design, make, evaluate and communicate	Structures, Processing, Mechanical and Electrical/ Electronic Systems and Control	(Technology, Society and the Environment) Indigenous/Impact/Bias
Design Process Skills:	Knowledge:	Values and Attitudes:
50%	30%	20%

NB: The above weighting for assessment should guide the approach to teaching in Technology. Most of the knowledge will be acquired purposefully during the development of design process skills. For example, learners will investigate required knowledge aspects, and will evaluate the possible impact on society or the environment.

Recording and reporting

Recording is a process in which the teacher documents the level of a learner's performance in a specific assessment task. It indicates learner progress towards the achievement of the knowledge and skills as prescribed in the Curriculum and Assessment Policy Statements. Records of learner performance should provide evidence of the learners' conceptual progression within a grade and their readiness to progress or be promoted to the next grade. Records of learner performance should also be used to verify the progress made by teachers and learners in the teaching and learning process.

Reporting is a process of communicating learner performance to learners, parents, schools and other stakeholders. Learner performance can be reported in a number of ways. These include report cards, parents' meetings, school visitation days, parent-teacher conferences, phone calls, letters, class or school newsletters, etc. Teachers in all grades report in percentages for the subject. The various achievement levels and their corresponding percentage bands are shown in the table below.

CODES AND PERCENTAGES FOR RECORDING AND REPORTING

RATING CODE	DESCRIPTION OF COMPETENCE	PERCENTAGE
7	Oustanding achievement	80-100
6	Meritorious achievement	70-79
5	Substantial achievement	60-69
4	Adequate achievement	50-59
3	Moderate achievement	40-49
2	Elementary achievement	30-39
1	Not achieved	0-29

Note: The seven point scale should have clear descriptions that give detailed information for each level. Teachers will record actual marks for the task by using a record sheet and report percentages for the subject on the learner's report card.

Moderation of assessment

Moderation refers to the process that ensures that the assessment tasks are fair, valid and reliable. Moderation should be implemented at school, district, provincial and national levels. Comprehensive and appropriate moderation practices must be in place for the quality assurance of all subject assessments. All Grade 9 tasks are internally moderated. The subject head or head of department for Technology at the school will generally manage this process.

Assessment taxonomy

The next table provides a possible hierarchy of cognitive levels that the teacher can use to ensure tasks include opportunities for learners to achieve at various levels and tools for assessing the learners at various levels.

Knowledge Recall	Understand	Apply	Evaluating	Analyzing	Synthesising
30%	40%		30%		
LOW	MIDDLE		HIGH		
Count Define Identify Label List Match Name Outline Point out Quote Recite Repeat Reproduce Select State Trace	Classify Compare Convert Discuss Distinguish Define Describe Estimate Explain Generalise Give examples Illustrate Infer Interpret Match Paraphrase Plan Restate Rearrange Rewrite Select Summarise Translate	Change Compute Construct Demonstrate Draw Illustrate Predict Relate Solve Use	Breakdown Differentiate Discriminate Investigate Relate Separate	Arrange Combine Compile Construct Create Design Formulate Generalise Generate Group Integrate Organise Summarise	Appraise Conclude Contrast Critique Criticise decide evaluate Grade Justify Interpret Support Recommend

Summary of assessment

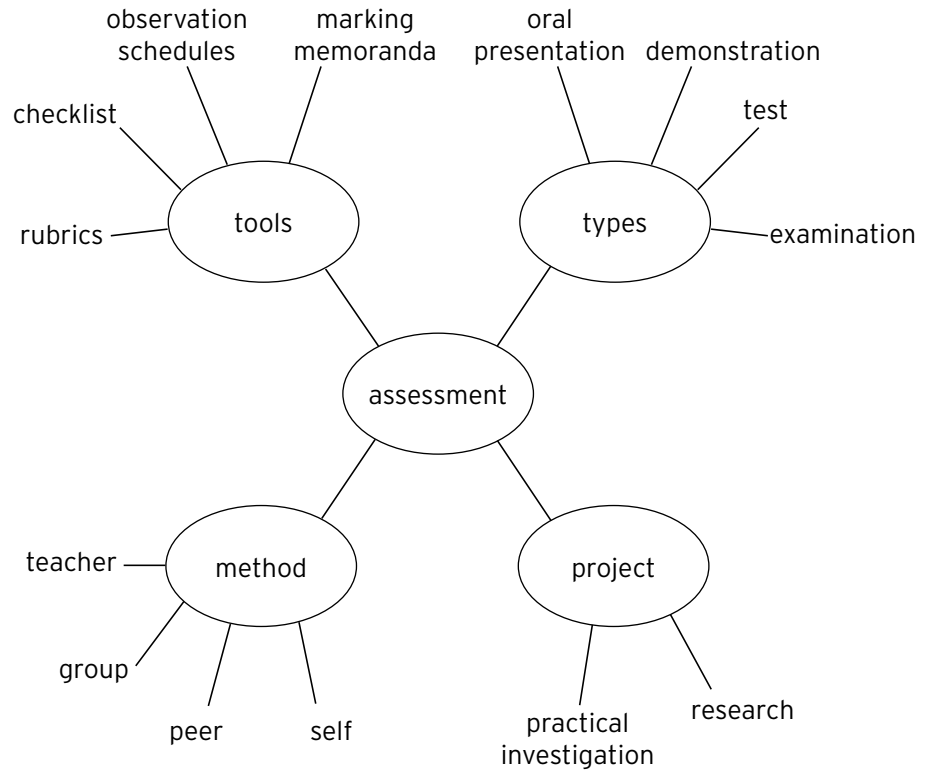

Section D: Teaching Guidelines

TERM 1

Module 1: Structures

Unit 1.1 Graphic communication.....	D5
Unit 1.2 Structures: Forces, strength and properties	D7
Formal assessment task: Mini-PAT 1	D11

TERM 2

Module 2: Mechanical systems and control

Unit 2.1 Hydraulics and pneumatics	D31
Unit 2.2 Pulleys	D44
Formal assessment task: Mini-PAT 2	D53

TERM 3

Module 3: Electrical systems and control

Unit 3.1 Revision: Component symbols	D61
Unit 3.2 Revision: Simple circuits	D68
Unit 3.3 Ohm's Law	D70
Unit 3.4 Action research: Testing Ohm's Law	D70
Unit 3.5 Resistors	D72
Unit 3.6 Components	D73
Unit 3.7 Simple electronic circuits	D76
Formal assessment task: Mini-PAT 3	D78

TERM 4

Module 4: Processing

Unit 4.1 Preserving metals	D86
Unit 4.2 Indigenous technology: Preserving food	D88
Unit 4.3 Processing plastic.....	D91
Unit 4.4 Re-use of waste plastic	D92
Formal assessment task: Mini-PAT 4	D95

1

TERM

During this term you will revise pneumatics and hydraulics and do some practical applications using syringes. You will do research on force transfer and on Pascal's principle. You will take a closer look at the hydraulic press and the hydraulic jack. This term you will investigate pulleys and a variety of mechanical control systems, and revise the interactions of different gears. You will investigate a situation so that an appropriate machine can be designed to solve the problem and produce appropriate sketches.

Unit 1.1

Graphic communication

Week 1

You will facilitate learning about first angle orthographic projection, investigate three dimensional objects on paper and look at the three different views when drawing. Learners will also become familiar with the different line types, scales and dimensions.

What you will need for Week 1:

- drawing paper
- drawing pencils
- squared grid paper (see Section E)
- drawing instruments
- isometric grid paper (see Section E).

Lesson 1 LB p. 4

Discuss with the class what graphic communication in Technology is about. Refer to the *Study & Master Technology* grades 7 and 8 learner's books.

Discuss terms such as front view, side view and top plan view.

ACTIVITY 1 Draw an L-shape in first angle orthographic projection LB p. 5

Individual

Work through the drawings step-by-step and discuss the layout.

ACTIVITY 2 Drawing orthographic projections LB p. 7

Individual

Guide the class through the process of drawing a cube in first angle projection.

Ask the learners to draw an H-shape. Give the class squared grid paper to draw the different views. Let them draw the H-shape using instruments.

Let the learners draw the different views of Figure 1.9. They may have to complete this exercise as homework if there is not enough time in class.

ACTIVITY 3 Extension/homework LB p. 8

Individual

1. Give the learners squared paper and let them draw an orthographic projection of Figure 1.10.
2. a) = E
b) = A
c) = C
d) = B
e) = F
f) = D

Lesson 2 LB p. 9

ACTIVITY 4 Line types LB p. 9

Class

Work through the descriptions of the different lines and their uses.

Discuss the need for scale when required to do drawings. Explain carefully the difference between scaling up and scaling down.

ACTIVITY 5 A scaled 3D drawing LB p. 11

Individual

Let the learners practise drawing by drawing the table using 1:5 ratio. Let them use the dimensions described in the Learner's Book.

Lesson 3 LB p. 12

ACTIVITY 6 A scaled 3D drawing LB p. 12

Individual

Discuss dimension lines and how to use them.

Give the class isometric grid paper. Let the learners measure your table. Remind them how to convert to draw to scale.

Week 2

The learners will draw 3D objects in orthographic projection using instruments. They will draw up a design brief with specifications for a given design problem.

Lesson 4 LB p. 13

Remind the learners about the purposes of a design brief and work through the rubric on page 14 in the Learner's Book with them

carefully so that they understand exactly how they are going to be assessed and what the criteria are.

ACTIVITY 7 Draw a plan LB p. 13

Individual

Once the learners have read and understood the checklist, they can begin to produce the design brief. Use the rubric to assess their design briefs and the working drawings that they will have produced.

Let them use the checklist for the design brief.

Unit 1.2 Forces, strength and properties

Week 3

Learners will find out more about the forces acting on structures, the strengths and properties of materials when acted on by forces and the properties of various construction materials.

Divide the class into groups of three to carry out the activities. If time is a constraint, then allocate half of the groups to one activity and the other half to the next activity.

Ensure that the groups carry out the experiments scientifically and record their results. Each group must allocate a speaker to present their findings to the class.

Lesson 5 LB p. 15

Discuss with the class the difference between a static and a dynamic load. Let the class provide their own examples.

Discuss the idea of internal and external forces within a structure.

ACTIVITY 8 Self-assessment LB p. 17

Group

1. All forces are dynamic.

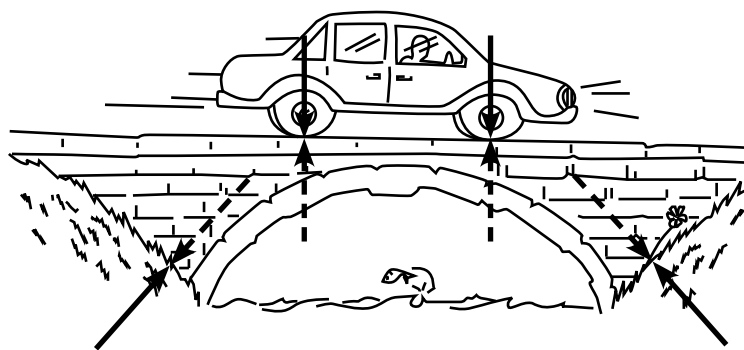

2. The see-saw will be in equilibrium.
3. Static – a load that cannot change

- Dynamic – a load that changes because of a moving force
4. Structure's own weight – static
Moving traffic on a bridge – dynamic
 5. Static – high rise buildings, pot full of soil
Dynamic – bridges, road flyovers
 6. Buckle, fracture and distort
 7. These are forces inside the structure – internal
Forces outside the structure – external
 8. When forces cancel each other out

ACTIVITY 9 Testing heavy loads LB p. 17

Group

Learners follow the instructions in the Learner's Book to build a bridge and do some tests. They record the findings of the tests and interpret these findings. They will reach the following conclusions:

- the highest deflection occurs at the centre of the beam
- the most dangerous place for it to stop is the centre of the bridge.

ACTIVITY 10 Strength of materials under the action of forces LB p. 18

Group

This can be demonstrated by you or conducted in groups, depending on time constraints.

Let the learners follow the instructions in the Learner's Book to complete the activity. They will reach the conclusion that a beam is stronger on its edge.

When looking at the pattern designs in Figure 1.25 on page 19 in the Learner's Book, the learners will reach the conclusion that the lattice is the strongest. The designs all use triangulation and support because this strengthens the beam bridge.

Look at and discuss the various examples of bridges on page 19 in the Learner's Book.

In Figure 1.30 (LB p. 20) the stiffest beam section is the second one, which is placed on its side and not bending.

INFORMAL ASSESSMENT Analyse for tension, compression and torsion LB p. 22

Pair

1. Member AB
2. Tension
3. The points X and X would move apart

4. Member CB
5. Points X X would cross over one another
6. A general rule would be to ask yourself, “What would happen to the member if it broke? Would the two ends move apart or cross over each other?”
7. Good under tension: EF
Good under compression: ED, DF
8. We use cross-bracing to support the members
9. Triangulation
10. Tension

Lesson 6 LB p. 23

Show the learners a range of different materials, such as cardboard, paper, a piece of concrete, wood, brass, steel, iron, copper and ask them to describe the examples, discussing their qualities or properties.

Then go through the questions on page 23 in the Learner’s Book with respect to the different materials.

ACTIVITY 11 Materials and their properties LB p. 23

Group

Divide the learners into groups of three and explain carefully how to proceed. The instructions are in the Learner’s Book.

As a group assessment, the learners must complete the activity and then as a class, discuss their findings.

ACTIVITY 12 Homework LB p. 27

Individual

Let the learners complete Activity 12 for homework. You can mark this yourself or let the learners mark each other’s homework.

Picture A: Elephants tugging	Tensile strength: This is the strength needed to pull a material apart by breaking the atoms.
Picture B: Bicycle chain	Tensile strength: This is the strength needed to pull a material apart by breaking the atoms.
Picture C: Boy’s reaction to heat from candle	Conductivity: Electricity can easily flow through this material.
Picture D: Panel being formed	Malleability: This is when a material can be pressed into shape without breaking.
Picture E: Brass pins on plug	Conductivity: Electricity can easily flow through this material.
Picture F: Hammer hitting material into shape	Malleability: This is when a material can be pressed into shape without breaking.

Picture G: Saw cutting wood	Hardness: This is when a material will not break when hitting something else.
Picture H: Elephants pushing towards each other	Compressive strength: This is the strength the material has to resist being squeezed.
Picture I: Filing a piece of metal	Hardness: This is when a material will not break when hitting something else.
Picture J: Making wire	Ductility: This is when a material can be drawn out without breaking.
Picture K: Hammer hitting nail	Toughness: This is when a material will not break when hitting something else.
Picture L: Boy bending rod	Toughness: This is when a material will not break when hitting something else.

ACTIVITY 13 Different building materials LB p. 29

Individual

Learners look at the different cross sections of the houses and complete the table.

House 1	Materials	Function
	wooden poles	framework
	reeds	covering roof
	natural fibres	joining
	sand, dung,tar	sealing, flooring
	window glass	protection, light
	sods	build walls
	ant heap, linseed/ox blood	flooring
House 2	saplings	framework
	grass	covering roof
	mud, clay, cow dung	sealing, flooring
House 3	bricks	walls
	glass	protection, light
	plastic	roofing
	cement	walls
	stones	walls
	wood	walls, beams

Safety procedure LB p. 32

In groups, let the learners come up with ten safety rules when working in the Technology room. This activity should not take longer than ten minutes for the learners to brainstorm. As a class read through the safety rules and ascertain whether they came up with any other rules.

Week 4

Guide the learners through the tender process so that they understand what is required of them in the Mini-PAT.

Lesson 7

Formal Assessment Task: Mini-PAT 1 LB p. 33

Topic: Structures

Task 1: Simulation

Group

Divide the class into groups. Discuss the different roles that members of the group must fulfil. Each group must choose a member to fulfil the different roles.

Discuss with the learners concepts such as tendering, a business plan, credit, investors, risk, and competition. Use an example with which the learners are familiar, for example, setting up a tuck shop at school. Look at the advantages of a business plan when establishing a tuck shop. It is essential that the learners understand the principles underlying the creation of a small business.

The learners must work in the groups in which they will function for the rest of the term. Each group must start thinking about their business plan and making notes, which will aid them in compiling their business plan.

ACTIVITY 14 Advert LB p. 35

Group

Let the groups read through the activity and answer the questions in writing. This could be used as part of their assessment.

Peer assessment – each group must swap their answers with another group and assess their responses.

Possible answers

1. The Msunduzi Municipality
2. To supply manufacture and erect 'Y' type passenger shelters at various sites within the Msunduzi Municipality
3. Minimum CIDB Contractor Grading of 2CE and/or 2GB or higher
4. Supply Chain Management Unit Offices, 5th floor, AS Chetty Building, 33 Church, St, Pietermaritzburg from 12h00 on Thursday, 21 July 2011
5. R136,80
6. To show that you are genuinely interested in tendering
7. No
8. To prevent fraud/invalid cheques
9. 12h00, Thursday, 11 August 2011
10. 90 days commencing from the closing date of tender
11. BEE is Black Economic Empowerment, which redresses the inequalities of the apartheid era by giving previously

disadvantaged South African citizens (black Africans, coloureds, Indians and some Chinese) economic opportunities previously not available to them.

12. An SMME is a small, medium or micro enterprise

13. Why would the municipality expect businesses to support BEE/SMMEs?

Let the learners swap their answers with another group and assess their responses. Discuss the advertisement as a class.

Discuss the tender process with the class. Provide each group with a tender form (see page E5).

The tender process

Photocopy and hand out to the learners pages E20 and E21 about the tender process.

Any business wanting to tender must also join the local municipality's data base. An example of part of the form is included (see page E3).

A letter of appointment (see page E7) from the client has also been included so that each team can have a copy for their file. It outlines briefly what is required of each team.

Discuss with the class the problem facing the community of Jabulani. In their groups the learners must now allocate a specific role or roles (depending on the size of the group).

Once the group has decided on the allocation of roles, each member must be very clear as to his/her role within the group. Each member of the group must make a list of his/her tasks and hand it to the Project Manager. These must be kept in a file under a separate section for each member.

Put up the careers available in the field of building construction. The learners can read through these. Emphasise that different careers cater for different skills and interests.

The group needs to discuss factors that will affect their solution to Jabulani's problem.

Give each team a handout about the tender process and a Letter of appointment. You may find these documents in Section E.

Lesson 8 LB p. 36

ACTIVITY 15 Role description LB p. 36

Individual

Let the learners create a list of tasks that must be fulfilled in the role he/she has been allocated. Let the learners chat to people in their community to find out more about the responsibilities of the different roles. Assist those learners who need help.

Careers in construction

You may create a poster so that this information can be displayed in the classroom for the learners to read as the project progresses.

Site manager job description

Site managers are responsible for supervising construction sites and running construction projects. They are also known as site agents, contract managers, construction managers and building managers.

They are employed to prepare sites prior to the commencement of construction work (to set out the site and organise facilities), to plan projects and ensure that they meet agreed specifications, budgets and/or timescales and to oversee building work. Other responsibilities include:

- liaising with clients, professional staff (such as architects and surveyors) and the public
- reporting progress
- supervising contracted staff
- meeting subcontractors
- making safety inspections and ensuring construction and site safety
- checking and preparing site reports, designs and drawings
- maintaining quality control procedures
- motivating the workforce
- problem solving
- using specialist construction management computer applications.

Typical employers of site managers are:

- civil engineering companies
- building companies
- construction companies and contractors.

A small number also work for public sector organisations.

Qualifications and training required

Site managers need an appropriate qualification in construction/building management, building engineering/studies, construction engineering management or civil/structural engineering.

Relevant experience can be beneficial, although not essential. Some employers offer sponsorship, vacation work and “gap year” placements, which can provide valuable contacts and a useful insight into the profession. Speculative applications made early in the academic year are advisable, particularly to smaller employers.

Key skills for site managers include:

- good communication skills
- problem solving skills
- commercial awareness
- motivational skills
- team working skills.

Quantity surveyor job description

A quantity surveyor manages all costs relating to building and civil engineering projects, from the initial calculations to the final figures. Surveyors seek to minimise the costs of a project and enhance value for money, while still achieving the required standards and quality. Many of these are specified by statutory building regulations, which the surveyor needs to understand and adhere to.

A quantity surveyor may work for either the client or the contractor. They are involved in a project from the start, preparing estimates and costs of the work. When the project is in progress, quantity surveyors monitor expenditure.

The title of the job may also be referred to as a construction cost consultant or commercial manager.

Typical tasks may include:

- preparing tender and contract documents, including bills of quantities with the architect and/or the client
- undertaking cost analysis for repair and maintenance project work
- assisting in establishing a client's requirements and undertaking feasibility studies
- performing risk and value management and cost control
- advising on procurement strategy
- identifying, analysing and developing responses to commercial risks
- preparing and analysing costings for tenders
- allocating work to subcontractors
- providing advice on contractual claims
- analysing outcomes and writing detailed progress reports
- valuing completed work and arranging payments
- maintaining awareness of the different building contracts in current use
- understanding the implications of health and safety regulations.

Areas requiring more specialised knowledge include:

- offering advice on property taxation
- providing post-occupancy advice, facilities management services and life cycle costing advice
- assisting clients in locating and accessing additional and alternative sources of funds
- enabling clients to initiate construction projects
- advising on the maintenance costs of specific buildings.

Candidates also need to show evidence of the following:

- practical and logical qualities, and a methodical way of thinking
- a creative and innovative approach to problem-solving
- strong numeracy and financial management skills and the ability to learn sophisticated design and costing IT packages
- the ability to write clear and precise reports and to relate complex information simply to a diverse range of people

- negotiating and team-working skills and the ability to motivate and lead those on site
- detailed knowledge of past and current building and construction technology, business and legal matters.

(<http://targetjobs.co.uk/careers-advice/a-to-z-of-careers/site-manager>)

Engineer job description

Engineers are problem solvers who use their expertise in science and maths to do their job. They work in various branches of engineering including aerospace, agricultural, biomedical, chemical, civil, computer hardware, electrical and electronics, environmental, industrial, materials, mechanical, mining and geological, nuclear and petroleum.

Engineers who work in design and development:

- design, plan, and supervise the construction of buildings, highways, and transit systems
- develop and implement improved ways to extract, process, and use raw materials
- develop new materials that both improve the performance of products and take advantage of advances in technology
- analyse the impact of the products they develop or the systems they design on the environment and on people using them.

Engineers who work in testing, production, or maintenance:

- supervise production in factories
- determine the causes of breakdowns
- test manufactured products to maintain quality
- estimate the time and cost to complete projects.

Civil engineers design things. These might be roads, buildings, airports, tunnels, dams, bridges or water supply and sewage systems. They must consider many factors in their designs, from the costs to making sure the structure will stay intact during bad weather. This is one of the oldest types of engineering.

Many civil engineers manage people and projects. A civil engineer may oversee a construction site or be a city engineer. Others may work in design, construction, research and teaching. There are many specialties within civil engineering, such as structural, construction, environment and transportation. Civil engineers usually work in areas where there is a lot of manufacturing and businesses.

Educational requirements for engineers

To get an entry-level engineering job, one usually needs a bachelor's degree in engineering. Sometimes a bachelor's degree in Physical Science or Mathematics may suffice, especially in high-demand specialties. Generally, engineering learners specialise in a particular branch of engineering.

A degree in engineering is needed for almost all beginning engineering jobs. College graduates with a degree in a science or Mathematics may get some jobs. A civil engineer must get a licence from the State to offer services directly to the public. A licence requires 4 years of relevant work experience and passing an exam. Beginning engineers often work under an experienced engineer to learn as much as possible. To teach engineering, further schooling is needed.

Getting into engineering at tertiary level requires know-how of Mathematics and science, and courses in English, Social Studies and computers.

Engineers should be creative, curious, analytical and detail-oriented. They should be able to work as part of a team. People skills are important. This is because engineers often work with people in a wide range of fields.

(<http://targetjobs.co.uk/careers-advice/job-descriptions>)

Architect job description

An architect designs buildings, houses and other structures. They are commissioned by a group of people or individuals who want well-designed structures. These structures are not built just for aesthetic purposes but also for functionality. An architect might also be commissioned to look over construction plans to make sure every specification is met. This task is often done with the help of an engineer who oversees the general construction of the design made by architect.

The architect's drawings have complete specifications, which should be followed when the drawing is implemented. Aside from working directly on paper, they could also transfer their work on computers. An architect could also be seen working onsite where they make sure their plans are properly implemented.

Training and education requirements

A degree in architecture is a must for those considering this career. The degree usually requires five years of education and training where learners are constantly exposed to different types of structures and how they can be properly designed. After five years of training and education, an aspiring architect has to pass the licensure exam. Success in the industry often comes with experience, as people often prefer to work with architects that have worked on some projects in the past.

An architect can work for the government, private companies and individuals. Aside from designing structures for companies and private individuals, an architect can also work as a teacher with universities or technikons that offer architectural degrees.

Many architects work independently after setting up their own construction company or architecture firm. They can also work as freelance architects working for different institutions that would require his or her services to design a structure.

Week 5

Learners will solve the problem and look at initial ideas. They will evaluate and adopt a final idea.

Lesson 9 LB p. 36

Take a look at the various steps in bridge building. The steps are not consecutive steps and are offered to give learners a better idea of how bridges are built.

The photographs on pages 38 and 39 in the Learner's Book are of a bridge being built in Hermanus.

Take a brief look at an alternative to traditional bridge building materials – recycled plastic.

Also, allow the learners to consider that building a bridge may not be the only solution to the problem. Allow them to be creative about their solutions.

ACTIVITY 16 Discussion LB p. 41

Group

Before designing the bridge, the learners need to consider the information on pages 41 and 42 in the Learner's Book. A scribe must be appointed by the project manager to record briefly the main points of the discussion and any issues that require further discussion or research. These notes must also be kept in the file as they will form part of the assessment of the project.

ACTIVITY 17 Sketch ideas LB p. 43

Group

Let each learner work individually to produce two possible ideas to solve the problem. Once these sketches and ideas have been submitted, the group, under the guidance of the project manager and design engineer, must look critically at each proposal and decide on a final idea. Each member must be ready to defend and explain his/her idea. Encourage the groups to discuss the pros and cons of each idea and provide help where necessary. Mediate if there is an impasse.

Lesson 10

ACTIVITY 18 Design skills LB p. 43

Group

Discuss as a class the concept of a design brief with specifications.

Make suggestions as you visit each group to ascertain how each group is progressing.

ACTIVITY 19 Create a flow chart LB p. 43

Group

Each group must now discuss the order in which they will tackle the project. They then record the order of work in the format of a flow chart for each learner, highlighting his/her section of the work.

A flow chart must record the steps logically. Any two tasks done simultaneously will appear in blocks alongside each other.

Week 6

During Week 6 learners will draw plans using first angle orthographic projection with scale, line types and dimensions. They will also cost out a budget for their project.

Lesson 11

ACTIVITY 20 Working drawings LB p. 43

Individual

Discuss very briefly the constraints when drawing a first angle orthographic projection.

Making and costing skills

Read through the costing process, ensuring that the learners understand how to cost the materials, the labour and the overhead costs. Provide your learners with a Bill of Quantities so that each team can cost their budget.

Explain that this is exactly what the companies who are tendering for a particular job are required to do before submitting a tender.

The learners must then submit a detailed costing of their project.

Lesson 12

ACTIVITY 21 Costing the budget LB p. 45

Group

Let the learners draw up a budget for the project and keep it in their project file. Assist groups who are struggling to do this activity.

Week 7

The learners will build their model to scale.

Lessons 13 and 14

ACTIVITY 22 Building skills LB p. 45

Group

The learners must work together building their models. Remind the learners about:

- safe working practices
- the model must be neatly built
- it must be to scale
- it must show intelligent use of material.

Week 8

The learners will develop a rubric as a team to evaluate their own and other teams' work.

Lessons 15 and 16

ACTIVITY 23 Rubric creation LB p. 46

Group

The teams must now work together to produce a rubric, which they will use to assess their own and the other groups' models. Refer the learners to the rubrics used in previous projects as a guide for their thinking. Examples are available in the grades 7 and 8 *Study & Master Technology* textbooks.

Week 9

Each group will present their tender bid to the Board.

Lessons 17 and 18

ACTIVITY 24 Communication skills LB p. 47

Group

Each team will present its tender bid to the 'Tender Board'.

When assessing the team ensure that each member is responsible for a certain aspect of the presentation.

Let the learners use the Level of effectiveness rubric to assess the level of effectiveness of each group's presentation.

Assessment

Project manager

Teacher/peer	
Achievement level	
Exceptional	Organised, good delegation, good co-operation with team
Achieved	Organisation, delegation fairly effective, co-operation not always evident
Minimum level	Organisation, delegation sketchy, poor leadership
Lacked achievement	Ineffective as leader, poor organisation, delegation

Finance manager and accountant

Teacher/peer	
Achievement level	
Exceptional	Budget well laid out, neat, accurate calculations
Achieved	Calculations accurate, recording neat but did not reflect good accounting practices
Minimum level	Calculations inaccurate, poorly recorded
Lacked achievement	Failed to keep records

Construction manager

Teacher/peer	
Achievement level	
Exceptional	Organised building of model effectively, workmanship excellent, built to scale, effective use of materials
Achieved	Led building well, workmanship good, built to scale, fair use of material
Minimum level	Led the building, workmanship poor, not accurately scaled, waste of materials
Lacked achievement	No responsibility for building, workmanship poor, not accurately scaled, waste of materials

Design engineer

Teacher/peer	
Achievement level	
Exceptional	Collated excellent sketched ideas of team, plans used first angle projection with scale, line types and dimensions, artistic representation excellent
Achieved	Collated sketched ideas of team, plans used 1 st angle projection with scale, line types and dimensions, artistic representation good
Minimum level	Sketches average, plans lacked certain key elements, artistic representation adequate
Lacked achievement	Failed to take responsibility, sketches poor as are plans with key elements missing, artistic representation poor

Site manager

Teacher/peer	
Achievement level	
Exceptional	Collected sufficient suitable materials, ensured safe working practices, managed tools and equipment well
Achieved	Materials collected, safe working practices, fair management of tools and equipment

Minimum level	Adequate material collection, poor working practices, tools and equipment not always managed
Lacked achievement	Poor material collection, poor working practices, tools and equipment poorly managed

Analyst

Teacher/peer	
Achievement level	
Exceptional	Design brief excellent, rubric excellent, good evidence of analysis of material usage
Achieved	Design brief good, rubric good, evidence of analysis of material usage
Minimum level	Average design brief, average rubric, little evidence of analysis of material usage
Lacked achievement	Poor design brief, poor rubric, no analysis of material usage

Team dynamics

Teacher/peer	
Achievement level	
7	All team members performed effectively, co-operated and supported each other very effectively
6	All team members performed effectively, co-operated and supported each other
5	All team members performed effectively, but argued often
4	Some team members performed well but took over others' roles
3	Some team members performed well, but some members were passengers
2	Some team members tried, but product poor
1	Little co-operation, product not completed in time

Week 10

Learners will do a formal assessment task of the work completed during this term.

2

TERM

During this term you will revise pneumatics and hydraulics and do some practical applications using syringes. The learners will do research on force transfer and on Pascal's principle. They will take a closer look at the hydraulic press and the hydraulic jack. The learners will investigate pulleys and a variety of mechanical control systems and revise the interactions of different gears. They will investigate a situation so that an appropriate machine can be designed to solve the problem.

Unit 2.1 Hydraulics and pneumatics**Week 1**

Revise syringe mechanics, looking at pneumatic and hydraulic systems. Let the learners experiment with different sizes of syringes and experience force transfer. They will also research Pascal's principle.

What you will need for Week 1:

- equal sized syringes
- plastic tube or rubber tubing
- different sized syringes
- small plastic bath of water
- wooden stand
- a cup
- safety goggles.

Lesson 1 LB p. 52**Hydraulics and pneumatics**

Learners learn about mechanical systems and control. They investigate syringe mechanics using two equal sized syringes linked by a tube. They identify the purpose of and difference between hydraulic and pneumatic systems. They are introduced to the basics of pneumatic and hydraulic systems, and apply the basic principles of these systems into a construction project.

Read the notes in the Learner's Book. Conduct a detailed discussion with the learners on the purpose of and differences between hydraulic and pneumatic systems. Use the experiments to facilitate the discussion. Learners will discuss their answers in class.

Pneumatic systems

Pneumatic and hydraulic systems work in the same way, and are used to provide powerful linear movement. The only difference is that hydraulic systems use pressurised oil to operate, while pneumatic systems use compressed air to operate. We are going to concentrate on pneumatic systems. We will look at what they are, how they operate and how they make our work easier.

Pneumatic systems use compressed air to make things work or move. Compressed air is the normal air you breathe, forced into a small space. Compressed air is used to pump up a bicycle tyre or to blow up a balloon. When used correctly, compressed air is a safe form of stored (potential) energy. Pneumatic systems consist of one or more rams (piston and cylinder units) that are supplied with compressed air through rigid or flexible tubes.

Pneumatic machines have many different uses. These systems transmit force and movement over long and short distances with very little friction. Pneumatic systems are used to control movement in small appliances, such as dentist drills. They are used in tyre fitting bays to undo and tighten wheel nuts, to remove old tyres from wheels and to inflate tyres. Automatic doors of buses and trains, truck brakes and construction drills are all examples of pneumatic systems. They can also be used in models and prototypes to control movement over a distance.

How pneumatic systems work

Pneumatic systems involve a source of compressed air that is controlled by valves and causes output devices such as cylinders to operate in a controlled way.

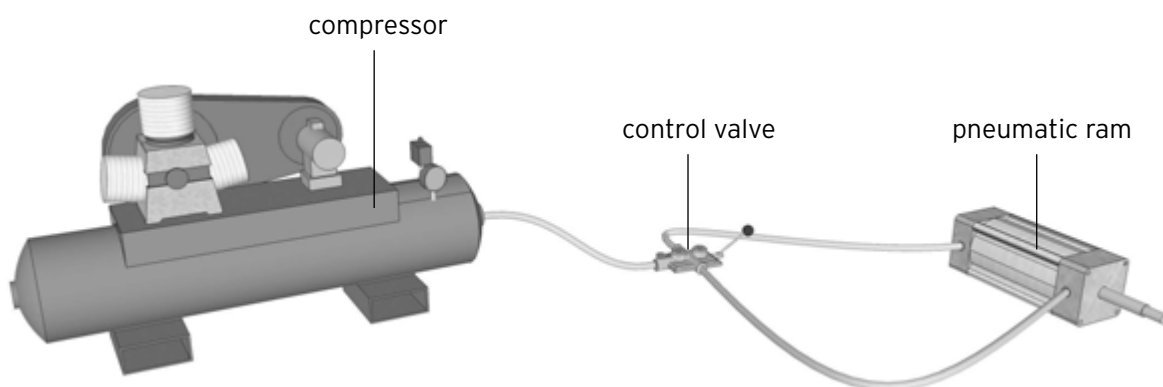

Compressed air is produced by a compressor. An open pneumatic system uses an air compressor and valves, which control the flow of air to the pneumatic ram (the piston and cylinder unit). A double acting ram can exert a pushing or pulling force, depending on which side of the piston air is admitted.

A compressor is a pump driven by an electric motor or an internal combustion engine that sucks air through filters and forces it into a strong metal tank, called a receiver. The air moves along narrow plastic or metal pipes to valves, which control the routing of the compressed air. A range of actuators, including levers, rollers and solenoids, may control the valves.

The air is then passed on to cylinders, which convert the energy in the compressed air into linear motion. Finally, the used compressed air is released into the atmosphere. During the process, the compressed air may pass through filters and lubricators to clean the air and add

lubricants. It may also pass through regulators to control the amount of pressure available in the system

Hydraulic systems

The extensive use of hydraulics to transmit power is due to the fact that a properly constructed hydraulic system possesses a number of favourable characteristics, such as:

- A hydraulic system eliminates the need for complicated systems using gears, cams, and levers.
- Motion can be transmitted without the slack inherent in the use of solid machine parts. The fluids used are not subject to breakage as are mechanical parts.

Hydraulic system mechanisms are not subjected to great wear. If the system is well-adapted to the work it is required to perform and if not misused, it can provide smooth, flexible, uniform action without vibration and is unaffected by variation of load. Hydraulic systems can provide widely variable motions in both rotary and straight-line transmission of power. The need for control by hand can be minimised. In addition, they are economical to operate.

ACTIVITY 1

Investigate a hydraulic and pneumatic system using two equal sized syringes LB p. 53

Group

Divide the class into two or more groups. Let them rotate so that all groups complete all the experiments and record their findings.

Group A (pneumatics) set up the experiment using air. Group B (hydraulics) set up the experiment using water.

Learners record results on the identification of the use of hydraulics and pneumatics as mechanisms. Let them record what they observe in their experiments in their workbooks.

Ask the learners the following questions: (See possible answers on next page.)

1. What happens when you apply a force on the plunger of the main cylinder? Explain your observation using the terms “hydraulic system” and “pneumatic system”.
2. Does one system push back? If so, give an explanation for this difference.
3. Which one moves more quickly?
4. Which one goes higher?
5. What causes the differences between water and air? Relate your answer to particle theory.
6. How do these differences affect the work that air and water do? Draw a comparative table on the board.

Possible answers

- The second plunger will move upwards.
The hydraulic system will move a greater distance than the pneumatic system because there is no compression in a hydraulic system.
- Yes – in the pneumatic system. In a pneumatic system the compression of the gases causes a force on both sides of syringe A.
- Hydraulic system
- Hydraulic system
- The particles in air are much further apart than the particles in water.
-

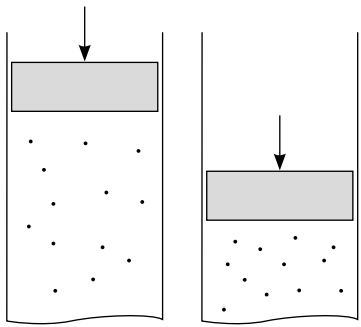
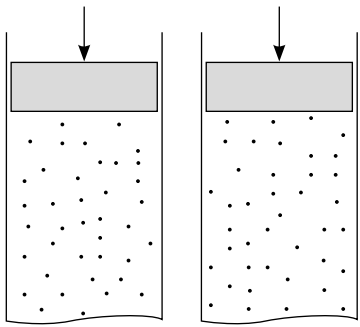
Gases	Liquids
	
Are very compressible because the gas particles are very spread out	Are not compressible, the particles in a liquid are not as spread out as in a gas

Pneumatics	Hydraulics
Confined pressurised systems that use moving air or gases	Confined pressurised systems that use moving liquids
Because gases can be compressed, there is a delay in the movement	Liquids are not very compressible, there is no delay in the movement
Need a compressor	
Examples Precision drills used by dentists, pneumatic brakes (air brakes) used by trucks, buses and trains, tampers used to pack down dirt and gravel, lungs, nail gun, dentist's chair	Examples Dump truck lift, hydraulic lift to lift cars, jaws of life, blood in body, used in cars

Pressure and force

The terms force and pressure are used extensively in the study of fluid power. It is essential that we distinguish between these terms. **Force** means a total push or pull. It is push or pull exerted against the total area of a particular surface and is expressed in grams.

Pressure means the amount of push or pull (force) applied to each unit area of the surface and is expressed in Newtons per square metre (N/m^2). Pressure may be exerted in one direction, in several directions or in all directions. Newtons (N) is the measure of force, therefore pressure is N/m^2 , otherwise known as pascals (Pa).

Pneumatic systems have two main features:

- a) Pneumatic systems use compressed gas, such as air or nitrogen, to perform work processes.
- b) Pneumatic systems are open systems, exhausting the compressed air to atmosphere after use.

Hydraulic systems too have two main features:

- a) Hydraulic systems use liquids, such as oil and water, to perform work processes.
- b) Hydraulic systems are closed systems, recirculating the oil or water after use.

Advantages of pneumatics

In pneumatics, a system needs only one power source. The work process creates a lower noise level than hydraulic systems, and pneumatic systems are relatively clean and operate at high speed. In addition, pneumatic systems feature lower component costs.

If you have access to the Internet, show the learners the picture of the small walking robot made using pneumatics at <http://groups.csail.mit.edu/lbr/boadicea>.

ACTIVITY 2 Self-assessment LB p. 55

Individual

Let the learners complete the self-assessment. Note the areas in which learners are struggling and address these with the specific learner.

1. A pneumatic system uses compressed air or gas to produce an output. Refer to the explanation on page D21 for an explanation of how pneumatic systems work.
2. Hydraulic systems use liquids, such as water or oil, to produce an output. Refer to the note on page D23 for an explanation of how hydraulic systems work.
3. Less effort is required to depress the pistons when the syringes are filled with water compared to the syringes filled with air.
4. The hydraulic system works better.
5. a) The syringe filled with water works better. The water cannot be compressed so the response of the pushing action is almost immediate.
b) The learners are expected to apply the knowledge they have and deduce what they think will happen. Let them explain their answers. They will conduct an experiment to investigate what really happens.

Lesson 2 LB p. 55

ACTIVITY 3 Investigate a hydraulic and pneumatic system using two different sized syringe LB p. 55

Group

When you push down on the plunger (a force), you create a certain amount of pressure inside the container (syringe). Tell the learners that the amount of pressure inside the container (syringe) depends on the amount of force applied to the plunger (how hard it is pushed) and the surface area of the plunger.

1. The plunger in syringe B moves up.
2. The plunger in syringe A moves up.
3. The force applied to one syringe is transferred to the other syringe.
4. This will vary from group to group.
5. A small input force over a small area can produce a large force over a large area.
6. If the area of a syringe is large, then the force required to push on that syringe is large too. If the area of another syringe in the same system is small, the force required to push on that syringe is small.
7. The large syringe. The large syringe is more difficult to press but the small syringe's plunger moves more.

Lesson 3 LB p. 56

Pascal's principle

Ensure that the learners understand that, according to Pascal's principle, the pressure exerted by the fluid will be the same in all parts of the container. In other words, any force applied to a fluid is transmitted in all directions throughout the fluid, even if the fluid is in two different containers (syringes) connected by tubing. Emphasise that the shape and size of the second container will not affect the pressure.

ACTIVITY 4 Construct a simple hydraulic system LB p. 58

Pair

Learners conduct the experiment and observe what happens. Learners will complete the answers to what they observed in this experiment.

When you push down on the plunger (a force), you create a certain amount of pressure inside the container (syringe). Tell the learners that the amount of pressure inside the container (syringe) depends on the amount of force applied to the plunger (how hard it is pushed) and the surface area of the plunger.

Does the syringe filled with air or the syringe filled with water work best? The syringe filled with water works best, because liquids are not compressible. If the two syringes are identical, then the force

produced by the second plunger will be the same as that exerted on the first plunger.

What do you think will happen when you use syringes of different sizes? The bigger the syringe, the bigger the plunger surface area and the more force it will produce. This is why, in the second part of the demonstration using syringes of two different sizes, the smaller mass was able to 'lift' the larger mass.

Learners learn about Pascal's principle: pressure exerted on one part of a hydraulic system will be transferred equally, without any loss, in all directions to other parts of the system.

Learners will record their observations in their books and come to their own conclusions regarding this experiment.

Discuss Pascal's principle. Make use of an experiment to show how this principle operates in theory. According to Pascal's principle, the pressure in one syringe is the same as the pressure in another syringe in the same system.

Let the learners read and do research on Pascal's principle and indicate where some of these applications are found.

Possible answers

1. The same effort is required.
2. The large syringe has a large area, so the force required is large too.
3. When you press the large syringe in the system, it is more difficult to press as you are moving a large amount of water, but the small syringe's plunger moves more.
4. A typical application of Pascal's principle for gases and liquids is the automobile lift seen in many service stations (the hydraulic jack). Increased air pressure produced by an air compressor is transmitted through the air to the surface of oil in an underground reservoir. Hydraulics is employed by modern devices ranging from very small to enormous. For example, there are hydraulic pistons in almost all construction machines where heavy loads are used.
5. Depressing the plunger in one syringe lifted the plunger in the other syringe. The force was transferred directly from one syringe to the other. Because the syringes were the same size
 - both plungers moved the same distance, but in opposite directions
 - one plunger moved down and the other plunger moved up
 - the force pushing down on one plunger was the same as the force pushing up on the other plunger.

Remind learners that pressure is the ratio of force to area. This means that if the area of one syringe is large, the force it takes to push on that syringe must be large also. If the area of another syringe in the same system is small, the force it takes to push down that syringe must be small also.

When you push down on the plunger (a force), you create a certain amount of pressure inside the container (syringe). Tell the

learners that the amount of pressure inside the container (syringe) depends on the amount of force applied to the plunger (how hard it is pushed) and the surface area of the plunger.

In this demonstration, the pressure will be the same in all parts of the system – the first syringe, the plastic tubing and the second syringe, regardless of its size (i.e. even if it is bigger than the first syringe). Learners may not understand that the pressure will not decrease in a larger syringe – they may believe that the pressure will ‘spread out’. Do not proceed with your explanation until learners understand the uniformity of the pressure. A drawing may assist in their understanding:

The pressure in the second syringe will create a force on the second plunger, pushing it outward.

The amount of force produced by this second plunger will depend on the pressure inside the syringe and the surface area of the plunger. If the two syringes are identical, then the force produced by the second plunger will be the same as that exerted on the first plunger.

At the same time, the bigger the syringe, the bigger the plunger surface area and the more force it will produce. This is why the smaller mass was able to ‘lift’ the larger mass in Activity 3.

Learners should clearly understand that using one small syringe (as input) and one large syringe (as output) is a good way of increasing force.

When you have finished your explanation, you can tell learners that in mechanics, the use of fluid (water) power in this way is called hydraulics.

Learners should have noticed that it took much less force to push down on the small syringe and lift the load sitting on the large syringe. When the same load sat on the small syringe, it took a lot of force to push down on the large syringe and lift the load. Encourage learners to share anything else they observed.

Note that as equal volumes of liquid are moved through the systems, this results in different extensions (amount of movement) where syringes (cylinders) are of different sizes:

Safety concerns

Remind learners that liquids used in the laboratory must not to be consumed.

ACTIVITY 5 Hydraulics LB p. 59

Individual

Let the learners do research on any of the topics presented in the Learner’s Book. Remind them to enhance their research notes by including drawings.

Week 2

Arrange a field trip for the learners to view a hydraulic press in action.

Lesson 4 LB p. 59

Arrange an excursion to a place where a hydraulic press is used so that learners may see a hydraulic press in use.

You may also demonstrate of the use of a hydraulic jack.

ACTIVITY 6 How a hydraulic jack works LB p. 62

Group

Describe how the hydraulic jack works. Fluid is pumped into the piston and valves prevent its escape. This fluid generates pressure and lifts the load piston.

The water flows in the direction of A to B. From the water reservoir into the effort piston, then into the load piston and finally back into the reservoir.

The purpose of the valves is to release the pressure that builds up from time to time.

In nature, valves are used in the heart and blood vessels in animals and humans, geysers and volcanoes.

	Valve A	Valve B
Effort piston moves down	Open	Closed
Effort piston moves up	Closed	Open

ACTIVITY 7 Self-assessment LB p. 63

Group

Let the learners make a simple mechanism that shows how a pneumatic system works.

3. mechanical systems that are operated using air
4. mechanical systems that are operated using oils or liquids
5. garages to pump air, bicycle pumps, bus doors, train doors
6. car jacks, hydraulic jacks

For additional worksheets look at Siyavula <http://cnx.org/content/m31723/latest/> on the Internet.

Mechanical advantage - force multiplication LB p. 63

To calculate the mechanical advantage of a hydraulic system

An example of a simple hydraulic system is a hydraulic lift, which is used to lift motor cars. The system has a mechanical advantage of both power input and distance output.

The system consists of two pistons of different sizes, connected by a reservoir that is filled with a hydraulic liquid such as oil or water.

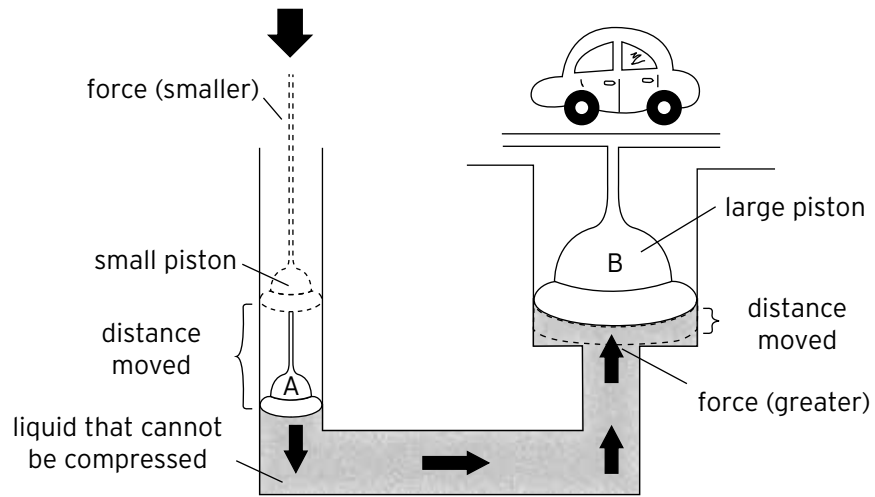

The following formula can be used to calculate the mechanical advantage:

$$\text{Mechanical force advantage} = \frac{\text{load (output force)}}{\text{effort (input force)}}$$

Mechanical advantage - distance output LB p. 64

In the syringes, the piston with the large diameter will have a smaller distance output and the piston with the small diameter will have a larger distance output. The relationship of distance output is determined by the mechanical force advantage. For example:

The motor car in the example below weighs 5 000 N. The small piston, A, has an area of 1 cm². The small piston moves a distance of 100 cm.

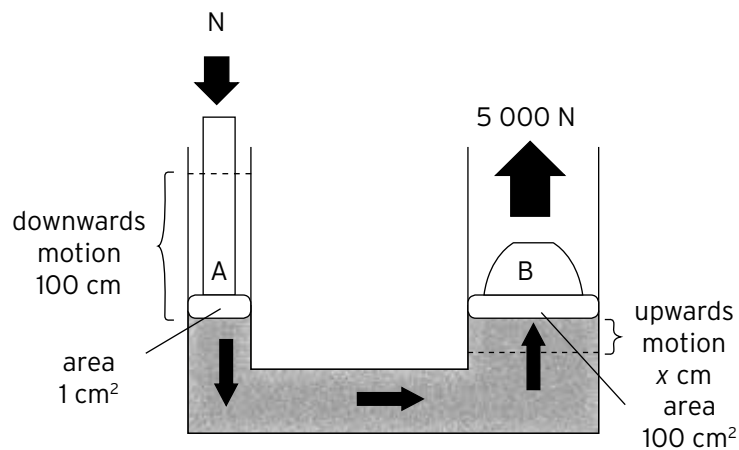

1. Determine the input force. According to Pascal's principle:

Pressure cylinder A = pressure cylinder B

$$\frac{\text{force A}}{\text{area A}} = \frac{\text{force B}}{\text{area B}}$$

$$\frac{\text{force A}}{1} = \frac{5\,000}{100}$$

Force A (the input force) = 50 N

2. The area at cylinder B is 100 times bigger. Therefore the power at cylinder A is 100 times smaller.

Determine the mechanical force advantage.

$$\text{MA} = \frac{\text{load}}{\text{effort}} = \frac{5\,000}{50} = 100$$

3. Determine the distance that the large piston will move.
 $MA = 100$. Therefore, if the small piston moves 100 cm, the large piston will move 1 cm.

Calculation 1 relating to Figure 2.15

1. $Work = force \times distance$
 $= 10 \text{ N} \times 0,1 \text{ m}$
 $= 1 \text{ Nm} = 1 \text{ joule}$
2. $Work = force \times distance$
 $Distance = \frac{work}{force}$
 $= \frac{1 \text{ J}}{100 \text{ N}}$
 $= 0,01 \text{ m}$
 $= 1 \text{ cm}$
3. $Pressure = \frac{force}{area}$
 $= \frac{10 \text{ N}}{10 \text{ cm}^2}$
 $= 1 \text{ N/cm}^2$
4. $Force = pressure \times area$
 $= 1 \text{ N/cm}^2 \times 100 \text{ cm}^2$
 $= 100 \text{ N}$

Calculation 2 relating to Figure 2.16

1. $Work = force \times distance$
 $= 100 \text{ N} \times 0,1 \text{ m}$
 $= 10 \text{ Nm} = 10 \text{ joule}$
2. $Work = force \times distance$
 $Distance = \frac{work}{force}$
 $= \frac{10 \text{ J}}{25 \text{ N}}$
 $= 0,4 \text{ m}$
 $= 40 \text{ cm}$
3. $Pressure = \frac{force}{area}$
 $= \frac{100 \text{ N}}{80 \text{ cm}^2}$
 $= 1,25 \text{ N/cm}^2$
4. $Force = pressure \times area$
 $= 1,25 \text{ N/cm}^2 \times 20 \text{ cm}^2$
 $= 25 \text{ N}$

Give each learner a copy of Assessment: Module 2 (in Section E).

Module 2 assessment memorandum

- 1
 - a) Force = 2 N
 - b) $MA = \frac{1}{2}$
 - c) 1,5 cm
 - d) No, the small piston/plunger will move the furthest and enable Jack to make the highest jump
- 2
 - a) The piston/plunger with a diameter of 1 cm
 - b) 1,5 cm

ACTIVITY 8**Working the hydraulic jack LB p. 66**

Group

Bring a hydraulic jack to class. Demonstrate how it works by operating it. Let the groups present their observations to the class.

Thereafter evaluate the design of the hydraulic jack in terms of fitness for purpose. Let the learners copy and complete the table in their workbooks.

Lesson 5 LB p. 67

Learners learn about drawing a systems diagram, which describes the way a hydraulic system works.

A 'systems' diagram is essential when planning a project. It allows you to show your idea(s) and whether or not they will answer the design problem. It also allows you to think systematically and logically about the design problem and how it can be solved. Above all, it keeps you 'on track' and does not allow you to wander too far away from the original design problem. A systems diagram is similar to a flow chart, although on first sight it is much simpler and more precise. The diagram is usually part of either the ideas or development sections. However, do not restrict yourself to these two areas. If you feel it is necessary, use this type of diagram wherever you like in the design process.

Explain systems diagrams by drawing a simple systems diagram that describes making a cup of tea, from filling an electric kettle to pouring the tea into a cup. Remember, almost every process can be divided into input, process and output. When learning about systems diagrams and how they can be used it is a good idea to practice drawing them by describing simple processes (like the example of making a cup of tea).

Please note: Although the example system diagrams shown below include electronics, system diagrams can be drawn for non-electronic projects/products as well.

How to present a systems diagram

1. The systems diagram is divided into three areas - input, process and output.
2. You should write about all the problems you are trying to solve in the INPUT area of the page.

The writing under the input drawing should be precise and to the point. There is no need for incredible detail. Include a limited number of inputs, expressed as simple statements.

3. In the PROCESS area describe the type of electronics and/or mechanisms that you intend to use in your project. Keep the descriptions of circuits and mechanisms generalised. Explain how the circuits/ mechanisms control the way your product will work. The person using your product may also be part of the PROCESS.
4. Explain in the OUTPUT area what you think will be the overall outcomes of your product.

ACTIVITY 9 Draw a systems diagram LB p. 67

Individual

Discuss how to draw a systems diagram. Talk about input, process and output.

Let the learners draw a systems diagram, which describes the way a hydraulic jack works. Concentrate on the input /process /output.

ACTIVITY 10 Hydraulic machinery LB p. 68

Individual

Let the learners examine several different pieces of hydraulic machinery found on a construction site and record what they do and how they work. Let them record their answers in their workbooks.

Here are some Internet resources that may be useful.

<http://www.technologylearner.com/index.htm>

<http://www.bbc.co.uk/schools/gcsebitesize/design/>

<http://www.btInternet.com/%7Ehognosesam/gcse/>

<http://www.designandtech.com/>

<http://www.deyes.sefton.sch.uk/technology/>

Unit 2.2 Pulleys

Week 3

The learners will do some practical investigations with regard to pulleys and force multiplication. They will also investigate the following mechanical control systems: ratchet and pawl, disc brake, bicycle brake and cleat.

Lesson 6 LB p. 68

Learners learn about pulleys using action research: Practical investigations.

Let the learners read the notes in the Learner's Book. Let them conduct experiments using pulleys to check how each of these pulley systems work. Let the learners record their observations and come up with conclusions to their findings.

Calculating mechanical advantage of pulleys

A pulley system consists of one or more combinations of wheels and ropes, which can be fixed in place or movable. Pulleys help you lift larger loads. To calculate the MA of a pulley, count the number of ropes/cables supporting the load.

ACTIVITY 11 Investigating pulleys LB p. 75

Group

What you need:

- a single wheel fixed pulley
- a single wheel moveable pulley
- a pulley block system (block & tackle)
- weights acting as loads
- rope.

Set up the various pulleys in your groups and investigate the working principles in each type of pulley mechanism. Record your answers in your workbooks and report to the class at the end of the lesson.

ASSESSMENT TASK Understanding pulleys LB p. 75

Individual

Let the learners complete the assessment task on their own.

Assessment task memorandum

- fixed
 - movable
 - block and tackle (6 marks)
 - The block and tackle system is a combination of several pulleys. A common block and tackle system includes a rope linking both fixed and movable pulleys (1 mark)
 - The number of efforts that help to lift the load is 4 (2 marks)
 - The mechanical advantage for this pulley system is: (2 marks)
$$\begin{aligned} \text{MA} &= \frac{\text{load}}{\text{effort}} \\ &= \frac{4T}{T} \\ &= 4 \end{aligned}$$
 - The load is 4 000 N. The effort needed to lift the motor car engine is: (2 marks)
$$\begin{aligned} \text{MA} &= \frac{\text{load}}{\text{effort}} \\ 4 &= \frac{4\,000}{E} \\ E &= 1\,000 \text{ N} \end{aligned}$$
 - The distance moved by the effort if this load is lifted 4 m is: (2 marks)
$$4 = \frac{\text{distance moved by effort}}{4}$$
Distance moved by effort = $4 \times 4 = 16 \text{ m}$
- [15 marks]

Lesson 7 LB p. 76

Learners learn about mechanical systems and control including ratchet and pawl, disc brake, bicycle brake and the cleat.

Bring examples of each of these mechanical control systems to class. Let the learners read the information in the Learner's Book.

Conduct a discussion with the learners on the four mechanical control systems pneumatic systems namely the ratchet and pawl, disc brake, bicycle brake and the cleat.

Ratchet and pawl LB p. 76

Show the learners how the ratchet and pawl works. Let them identify places where they've seen a ratchet and pawl in use.

Provide examples besides a winch and a ratchet screwdriver

Disc brakes/hydraulic brakes LB p. 78

Talk about the disc brakes. Let the learners identify the different parts of the disc brake.

ACTIVITY 12 Bicycle brake LB p. 81

Group

What you need:

- A bicycle with brakes.

Ask the learners to bring bicycles with brakes to school. Let the learners investigate how the brakes work. Let them record their findings in their Technology workbooks.

Cleats LB p. 83



Let the learners look at some of the different types of cleats available. Let them find out where cleats are used. They must each find at least two examples.

ACTIVITY 13 Mechanical control systems LB p. 83

Pairs

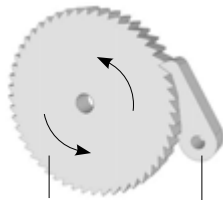
Let the learners briefly explain how a ratchet and pawl, car disc brakes, bicycle brakes and cleats work after they have investigated them in class. Let them draw line drawings of them and record their findings in their workbooks. They may present the information in the format of a table. This is an example. Consider all correct answers presented by the learners.

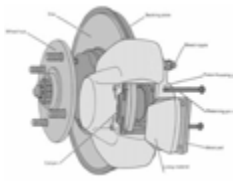
Mechanism name and drawing	Type of system	Where it is used	Mechanical advantage	How it is used
Ratchet and pawl 	Mechanical gear system	A good example is a ratchet screwdriver.	Can only be turned in a counter clockwise direction, designed to prevent reverse rotation (single-direction device)	A ratchet is a mechanical device that allows continuous linear or rotary motion in only one direction while preventing motion in the opposite direction

Mechanism name and drawing	Type of system	Where it is used	Mechanical advantage	How it is used
Disc brakes car 	Hydraulic	To apply brakes on cars	The pistons in the wheel cylinders exert a force on the brake pads, which rub against the rotating disc, slowing down and eventually stopping the vehicle	Pressing the brake pedal in the car, causes a small piston in the master cylinder to create a pressure in the brake fluid, which is transmitted to the wheel cylinders
Bicycle brake 	Lever and linkage	To apply brakes on bicycles	Brake power is simply how hard the brake clamps the rim, you must adjust your pads closer to the rim for your brakes to have a higher mechanical advantage	You pull the brake lever with your hand, the brakes cable grabs the lever, which pulls the brakes to grab the rim as the pads squeeze the rim
Cleat 	Mechanical	Cleat (shoe), a type or part of a shoe or cleat (nautical) a fitting on ships, boats and docks to which ropes are tied, also used to secure cords and flags to a pole		A rope or string is wound around the cleat to prevent it from moving

Week 4

This week learners will take a closer look at various kinds of gears.

Lesson 8 LB p. 84

Let the learners read the information in the Learner's Book. Let them revise the interactions of the following:

- spur gears of equal size counter-rotating
- spur gears of unequal size counter-rotating – note velocity/force relationships
- spur gears using an idler to synchronise rotation.

ACTIVITY 14 Design a handout LB p. 86

Individual

Let the learners design a handout explaining each of the gears that they have learned about in this section. Ask them to use a table form and record their information in it. They must include line drawings for each gear train used. Show them the format below to complete their handout. Assess their completed table. Accept all correct answers.

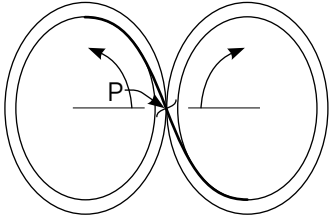
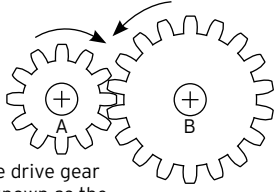
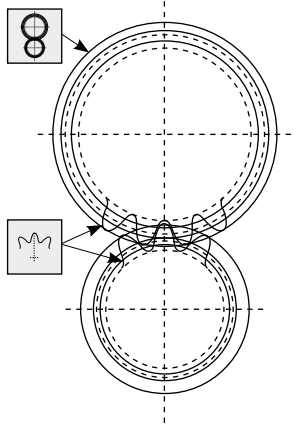
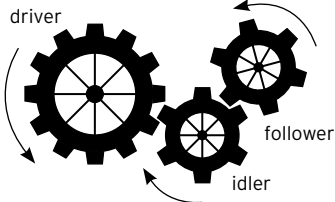
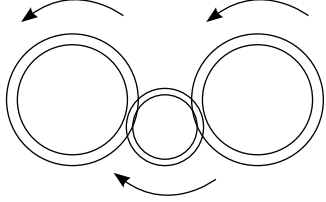
Gears	Diagram	Uses	Line drawing
Spur gears of equal size counter-rotating		When spur gears of equal size rotate, they move in opposite directions as the meshing takes place.	
Spur gears of unequal size counter-rotating - note velocity/force relationships	 The drive gear is known as the 'input gear'. The gear that is being turned is referred to as the 'output gear'.	The diagram shows a simple gear train with A as the driver gear and B as the driven gear. When A turns completely it only moves 15 teeth, therefore four revolutions of gear A will move gear B once. Therefore this acts as a mechanism that can slow down the movement.	
Spur gears using an idler to synchronise rotation		To get two gears to turn in the same direction, a third gear has to be meshed between the two gears. This gear is called an idler gear. An idler gear changes the direction of the movement of the other gear and is used to synchronise rotation. The driver and the driven gears can be made to rotate in the same direction.	





Lesson 9 LB p. 87

Conduct a discussion about bevel gears of equal size – axis of rotation 90° , bevel gears of unequal size – axis of rotation 90° . Note velocity/force relationships, rack-and-pinion gear systems as found on automatic gates and steering racks and worm gear systems for large reductions in speed and increases in force. Discuss their uses, and what each does in a mechanical gear system.

ACTIVITY 15 Gears LB p. 89

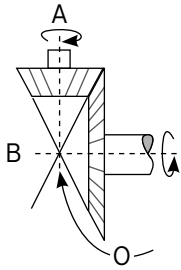
Individual

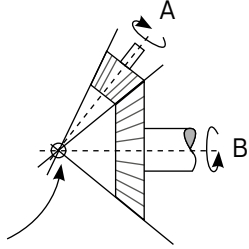
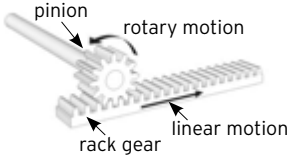
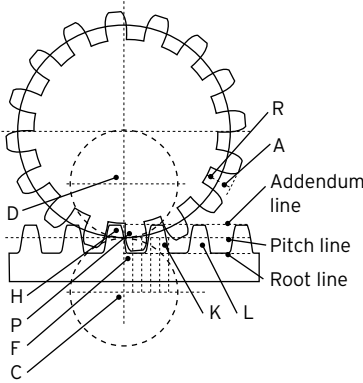
Let the learners complete a table while they investigate the various types of gears that they are learning about as mechanisms. Check whether all the learners have completed the task, correct the task and assist those learners who are struggling.

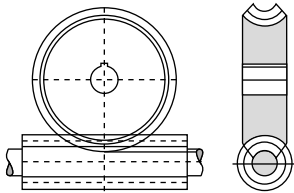
Gears	Diagram	Uses	Line drawing
Bevel gears of equal size		Bevel gears are used mostly in situations that require power to be transmitted at right angles (or applications that are not parallel).	
Bevel gears of unequal size		Bevel gears are used to change the direction of drive in a gear system by 90 degrees. The bevel gear can also increase the speed of the rotation	
Rack and pinion		Rack and pinion gear systems involve the use of a round gear called a pinion and a flat gear called a rack. This system is used to change rotary movement into linear movement and the other way round.	
Worm and gear		Worm gears are used to transmit power at 90° and where high reductions are required. The worm resembles a thread that rides in concaved or helical teeth. Worm gears resemble screws. A worm gear is usually meshed with an ordinary looking, disk-shaped gear, which is called the gear wheel or worm wheel.	

Week 5

This week learners will examine various items using mechanisms and they will create vanishing perspective drawings.

Lesson 10 LB p. 90

ACTIVITY 16 Evaluation and design skills LB p. 90

Group

Conduct a discussion with the learners on the mechanisms found in the kitchen/home/garage. Let them conduct the investigations

and evaluate each of the mechanisms according to set criteria. They can include any mechanism they choose. The table below is only an example.

HOME		KITCHEN		GARAGE		WORKSHOP		
Criteria	bottle openers	knives	egg beater	can opener	hand drill	vice grip	wire strip-pers	ratchet spanners
Who is it for?	people	people	cooks/chefs	cooks	carpen- ters	handy- man	electri- cians	mechan- ics
What is it for?	open bottles caps	for cutting	to beat eggs	to open cans	to drill holes	to hold equip- ment	to strip wires	to tighten or loosen nuts and bolts
Will it do the job	yes	yes	yes	yes	yes	yes	yes	yes
What material is it made of?	metal/ pewter	steel blades	metal/ plastic	metal	metal	metal	metal	metal
Is the material suitable?	yes	yes	yes	yes	yes	yes	yes	yes
What should it cost?	cost effective	cost effective	cost effective	cost effective	cost effective	cost effective	cost effective	cost effective
Does it look good?	yes	yes	yes	yes	yes	yes	yes	yes
Is it safe and easy to use?	yes	no	yes	yes	yes	yes	yes	yes

Check whether all the learners have completed the task. Correct the answers. Let the learners report on any three of these items, using the criteria listed.

Lesson 11 LB p. 90

Read the notes in the Learner's Book and do some demonstrations on the board or in a technical drawing room. Let the learners look at the examples of vanishing point perspective in the photographs. Let the learners find photographs or drawings that use vanishing point perspective and bring these to class to share.

ACTIVITY 17 Draw a 3D wooden object using single VP perspective LB p. 91

Individual

Learners are expected to draw a 3D wooden object using single vanishing point perspective. Teach this lesson to the class by doing a demonstration lesson on the board, explaining in detail all the steps

related to single point perspective and the terminology associated with this drawing. Learners are expected to enhance their drawings by adding: texture of wood grain, colour and shadows to their respective drawings.

ACTIVITY 18 Use single VP perspective to draw an inside view of the classroom LB p. 93

Individual

Learners are required to draw the inside of their classroom. They may follow the instructions in the Learner's Book or here are some alternative instructions for drawing a room. If you prefer these instructions, there is no harm in using it. There is not one single way of drawing a room.

Drawing a room in single point perspective

V. Ryan © 2002–2008 at <http://www.technologystudent.com>.

Look at the room shown below. Furniture has been placed inside it and a colour scheme added. Follow the instructions below and on the next page and draw the basic shape of a room – including furniture.

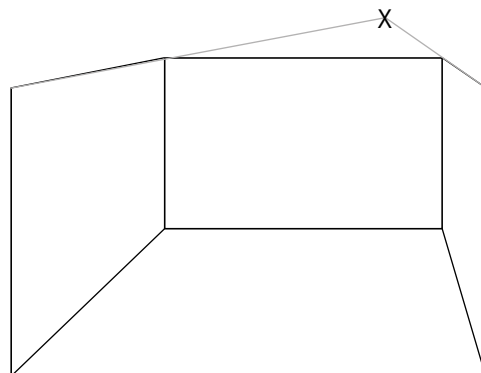
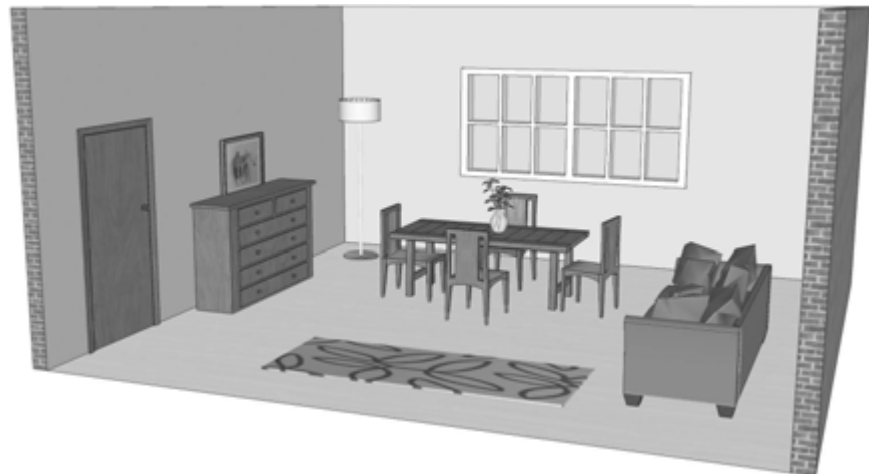

Once you have mastered drawing individual pieces of furniture in single point perspective, you will be ready to design a simple room, which includes basic furniture. The same techniques are used whether

drawing the skeleton of a room or the pieces of furniture inside it. Use a single vanishing point and project guidelines back to it.

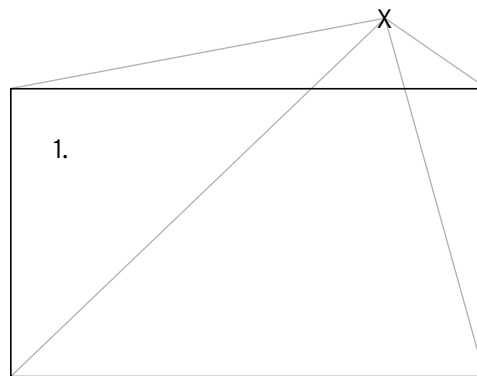

Draw a rectangle and project the corners back to a vanishing point. Remember, all lines should be faint at this stage.

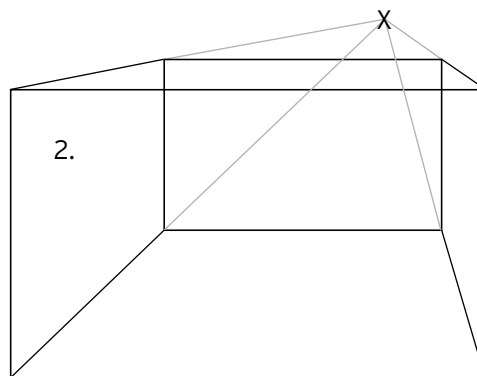

Draw a rectangle, which represents the back of the room. This must line up with the guidelines projected back to the vanishing point from the front rectangle.

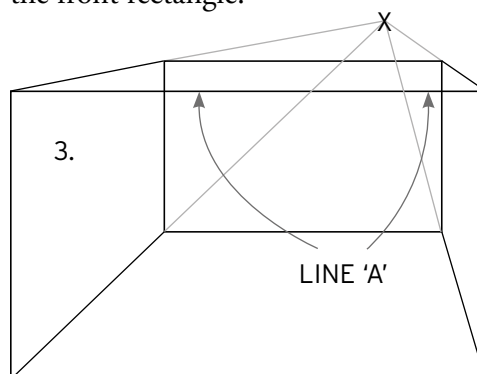

Complete the basic room by rubbing out line 'A' and darkening the outline of the entire room.

Learners will draw the inside of a classroom in single vanishing point perspective.

FORMAL ASSESSMENT TASK: Mini-PAT 2

LB p. 94

Describe a scenario where a machine combining at least two of the following sub-systems can be effective in giving a mechanical

advantage to make work easier: mechanical, electrical, pneumatic or hydraulic systems. The mechanical elements may consist of one or more of the following mechanisms: levers, linked levers, wheels, cams, cranks, pulleys and/or gears.

Discuss with the learners what will be expected of them in the practical making task. Learners will use all the knowledge that they have gathered and will attempt to come up with solutions to their design.

Let the learners read the notes in the Learner's Book. Clarify any points of confusion for the learners before they start the activity.

Week 6

Guide the learners to investigate a situation so that appropriate machinery can be designed to solve the problem and create a design brief.

Lesson 12 LB p. 95

ACTIVITY 19 Investigation skills LB p. 95

Pair

Let the learners chat to their partners about ideas that could solve the problem, need or want. They must investigate the situation so that an appropriate machine can be designed to solve the problem, need or want given in the scenario. They must investigate the possible mechanisms and controls to be used together to make the machine.

The learners should not limit their thinking to conventional solutions. Let each learner write his/her suggestions for the design giving specifications and constraints.

The learners should write a design brief with specifications and constraints for the problem. The design brief must be a short statement of the problem to be solved and not a description of the solution. An open brief allows for more creativity than a closed brief, which describes a solution.

The design brief could be something like this:

When people work in a factory, they see a need for a simple hoist to raise boxes of fabric from one floor to the next. Design a safe, remote-controlled hoist, which could make use of a factory's compressed air supply.

A checklist for a design brief

Checklist criteria	Yes	No
1. It is a short, clear statement of what must be done.		
2. It describes the problem and not a solution.		
3. It describes who will use it.		
4. It describes where it will be used.		
5. It describes the benefit a solution will have.		
6. It lists all of the constraints.		

The factors that will limit design ideas are the constraints. These can be stated as one word, for example, time, materials, tools, human resources, cost. These must be considered prior to listing the product specifications.

Lesson 13 LB p. 95

ACTIVITY 20 Design skills - sketches LB p. 95

Individual

Learners must draw two possible solutions to their designs. Sketches can be in isometric or oblique drawings. Each learner produces two sketches of viable possible designs. Thereafter, teams will meet and examine the individual suggestions and decide on a final solution.

Remind learners that they will present their model to the class. Conduct a discussion around presentations, research plans, flow charts, models and budget constraints in relation to the practical project.

Week 7

Learners will create working drawings using first angle orthographic projection.

What you need:

- for the model – tools, cardboard, hydraulic and pneumatic equipment, gears, pulleys
- for the presentation – chart paper, koki pens, data projector, laptop

Lesson 14 LB p. 95

Let the learners practise the orthographic projection presented in the Learner's Book. Let them read the notes to remind themselves of the different views.

ACTIVITY 21 Working drawings LB p. 97

Group

Demonstrate to the learners how to produce drawings for their model/prototype using first angle orthographic projection. Each team member draws a plan of the design or, if it is very complex, one or more aspects of the design. Each learner must demonstrate her/his competency in using this drawing technique.

The teams collaborate to produce drawings for their model/prototype using first angle orthographic projection.

You may use the following rubric to assess the learners' drawings:

Criteria	5	4	3	2	1	0
1. Accuracy of drawing						
2. Makes use of scale						
3. Makes use of all relevant lines						
4. Prints neatly and accurately						
5. Dimensions the drawing correctly						
6. Demonstrates good aesthetic design						
Total						

5	Outstanding achievement
4	Meritorious achievement
3	Substantial achievement
2	Moderate achievement
1	Elementary achievement
0	Not achieved

Lessons 15 and 16 LB p. 97

ACTIVITY 22 Make a prototype working model LB p. 97

Group

Learners will make a model of their design. Remind learners to work using safe working practices. The model must display a viable solution to the problem. It should be to scale and neat, and show intelligent use of available materials.

Week 8

The learners will present their solution.

Lesson 17 LB p. 97

ACTIVITY 23 Communication skills LB p. 97

Group

Learners must ensure that a full presentation is prepared and presented to the class. Learners do presentations in a team.

Each team is given five minutes to present their solution in the form of sketches, artistic impressions of the solution, working drawings/plans, costing and their model. Give each learner a copy of the self-assessment checklist – Graphic design as a design function (see page E6).

During this term learners will find out more about electrical and electronic systems and structures. They will also revise circuits and different forms of communication. Learners will also build their own circuits.

You will need to spend two hours each week on Technology. The lessons can be broken up into two one hour sessions or one two hour session. The work has been broken up into hour lessons. If the learners know a lot of the work and want to work ahead of the schedule, make sure they have covered the basics. There are some extension exercises that have been put in for the learners that work quickly and grasp the different concepts quickly.

Each lesson is divided up into one hour sessions. Make sure all the materials are available before starting your lessons.

Time is often a factor when trying to cover the different activities in the classroom. When covering a number of these activities, it would be easier to divide the learners into groups. Group. 1 can do Activity 1 and Group. 2 can do Activity 2, etc. Before the end of the lesson each group will give a report back of their findings. This will assist you in covering all the material required in each week.

Unit 3.1 **Revision of component symbols**

Week 1

In Week 1 the learners will learn about basic circuits, component symbols and Ohm's law.

What you will need for Week 1:

- a variety of electronic components
- cells
- batteries
- lamps/bulbs
- lamp/bulb holders
- insulated wire
- a variety of switches
- buzzers
- voltmeters
- ammeters
- buzzers
- bells
- 9 V cells

- insulated wire
- wire for making the loop
- a wooden base
- two dowel rods (or anything else that is suitable)
- glue
- nails
- Christmas tree lights
- a variety of resistors.

Before each group starts their activity, make sure that they have the components or materials needed. Remember, if you don't have a lamp holder, the lamp/bulb must be connected with wire on the side of the metal base of the lamp/bulb and the other insulated wire must be connected underneath or to the 'nipple' on the metal base.

Lesson 1 LB p. 100

ACTIVITY 1 Revision of component symbols LB p. 100

Pair

Let the learners look at the different symbols and their uses on page 101 in the Learner's Book. They can discuss the different components with a partner.

Did you know? Two cells make a battery.

Discuss this with the learners. If you have one cell it is called a 'cell' but two cells joined together become a battery.

The learners will discuss the symbols they will use in this module. See how many of these symbols they can identify. Read about what the different components are used for. The learners must learn the symbols that are required for the Grade 12 exams. They should learn the symbols for the different components.

They can discuss the difference between cells that are connected in series and cells that are connected in parallel. Once they know how to connect these they will understand the symbols.

You could make a poster of these components and their functions and keep it on the wall for the learners to refer to when they are working on circuits and circuit drawings. Make sure that the learners know the correct symbols for the electronic parts. The symbols are always required when they are drawing a circuit diagram.

The symbols for lamps/bulbs connected in series and parallel are different. The symbols look different and they also produce different results. The learners will discover this later on in the module.

It is important that the learners learn to put together the different connections. They might need to use them in their final design!

Switches connected in series and parallel also serve a different purpose. The learners will have learned this in grades 7 and 8.

ACTIVITY 2 Homework LB p. 101

Individual

Encourage learners to speak to people in their home environment about how some of the components may be used.

ACTIVITY 3 Cells connected in series and parallel LB p. 102

Group

It is important that the learners know how to put together the different connections and circuits.

Anything connected in series is normally one component connected to the other component next to it or, in other words, in a straight line. Remind the learners that when they connect the cells in series they connect them back to back or positive to negative. Let them read the + sign on the cell, etc.

A parallel connection is like parallel lines in Mathematics, the components are connected alongside each other. This will make it easier for the learners to remember the difference between the different connections. Remember that these types of connections can be used for a number of components, for example, cells, lamps/bulbs and resistors.

When cells are connected in parallel, the cells lie side by side. Label positive and negative on the cells and show how the wire has to connect the two cells together. The learners will get together in groups and discuss the different ways to connect cells.

Possible answers

Cells can be connected in a straight line or next to each other. Parallel cells are not connected with the same wire and are connected alongside each other.

Because there is a limited amount of time you may divide the class into groups, with one group connecting cells in parallel and another group connecting the cells in series. They can then demonstrate their connections.

ACTIVITY 4 Lamps/bulbs connected in series and in parallel LB p. 103

Group

Let the learners stay in the same groups and discuss the different connections when using lamps/bulbs.

Possible answers

When lamps/bulbs are connected in series, if one does not work the other will not work, but when you connect them in parallel they work independently. This makes the parallel connection more effective. The lamp/bulb in a parallel circuit also glows brighter and will still continue to work if one wire is cut.

Lamps/bulbs in series

When the learners connect lamps/bulbs in series they are connectde to the cells by the same wire. The current is shared by the lamps/bulbs.

ACTIVITY 5 Lamps/bulbs connected in series LB p. 103

Individual

See if the learners can connect this simple circuit in series with a cell. Note the brightness of the lamps/bulbs. What will happen if you add more than two lamps/bulbs?

Possible answer

Normally the lamps/bulbs are dimmer if you add more to the circuit. Sometimes one of the lamps/bulbs does not even light up.

Lamps/bulbs in parallel

When the learners connect lamps/bulbs in parallel, you can see that the wires connected to the cells are separate, insulated wires. They work independently from each other.

ACTIVITY 6 Extension LB p. 104

Individual

There are always learners that work faster than others. Allow them to do the extension activity. See if they can connect the bulbs in parallel. Note the brightness of the lamps/bulbs. If you add one more lamp connected in parallel, what happens?

Possible answers

The lamps/bulbs stay just as bright if you add another bulb connected in parallel.

The lamp that is still connected will continue to shine or light up if you cut one of the wires connecting the lamps.

The headlights of a car are connected in parallel or separately. If one lamp/bulb goes out or is broken then at least the other lamp will work until you can change the lamp.

Faults in circuits

It is important to teach the learners how to find faults in circuits. Often the learners blame the component when the circuit is not working, but it is often a faulty connection or something was joined incorrectly. Here is a fault finding check list. This can be made larger or be made into a poster so the learners can see it when their circuits are not working.

Fault finding in a circuit

Electrical circuits should never really break – you can fix them if you know how! Here are some things to check when building a circuit:

1. Is the circuit made to the circuit diagram? If not, correct it to match the diagram.
2. Are the joins firm? Check them. Make sure they have proper contact. Make them secure.
3. Is there a short in the circuit? This means that the connecting wires are touching. Try to fix it.
4. Is there a break in the wire? Replace the wire or fix the break.
5. Are the components connected in the correct order? Check and change the way they are connected.
6. Are the components working? Check each component, for example, the battery. Check each component with a meter or in another circuit.
7. Are the values of the components correct? Check that the values of the components match what is needed for the circuit.
8. Are the cells or battery connected the correct way? Reconnect them correctly.
9. Is the cell or battery strong enough? Replace the cell or battery.

If the circuit is not working try the steps again.

It is important to teach the learners these steps as they often say they cannot get their circuits to work when it is a simple fault. When learners work in groups, they can help the learners who are not sure how to connect the different components properly and they can learn from each other.

ADDITIONAL HOMEWORK TASK Steady hand game

This is an additional homework task, which you may give the learners if there is enough time and you think your learners might enjoy it. Let them make a 'Steady Hand' game using a circuit with a buzzer. This is a lot of fun, and it will help the learners build a game using a simple circuit. The 'switch' is the looped tool they use to play the game with. If the loop touches the wire, the lamp or buzzer goes on.

What you need:

- a buzzer
- a 9-voltage cell
- insulated wire

- wire for making the loop
- a wooden base
- two dowel rods (or anything else that is suitable)
- glue
- nails.

Work in groups and build the circuit from the diagram below:

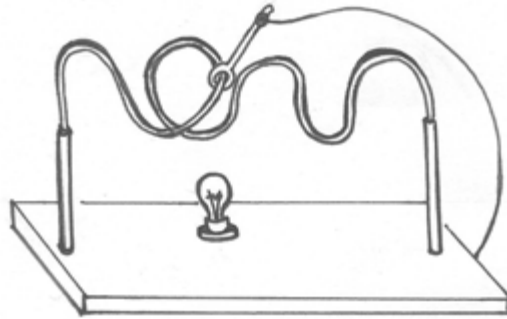

See if the learners can draw a circuit diagram for this game.

ACTIVITY 7 Switches LB p. 104

Individual

The learner will look at two different ways of connecting different switches. Remember a switch is a control device.

The simplest type of switch is represented by the symbol shown in Figure 3.6 on page 104 in the Learner's Book. Two parts are shown: a pole and a contact. It is called a single pole, single throw switch.

Remind the learners about the simple switches they learned about in grades 7 and 8.

Switches connected in series (AND logic)

If a switch is pressed down we know that it is on or it is said to be at logic state 1. An open switch or when the switch is off it is said to be at logic state 0. In other words, when a logic gate produces an output, the output is said to be at **logic state 1**, if there is no output means it is at **logic state 0**.

If the learners understand this basic knowledge about "logic" they will cope with the logic states and the Truth Tables. It is important that they understand this before they go onto the next activities.

The circuit in Figure 3.7 on page 104 in the Learner's Book is called the AND gate. Switch A and Switch B are in the off position.

ACTIVITY 8 AND logic LB p. 105

Pair

Allow the learners to work with a partner but if you have a big class then put learners into larger groups, they will look at the circuit

diagram in Figure 3.9 on page 105 in the Learner's Book and work out what will happen if one switch is pressed down.

Possible answers

If the learners press down one switch, the buzzer or lamp will not work. The circuit is still open so the circuit will not be on or work.







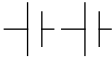
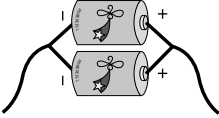
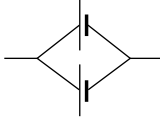

What will you have to do to make the buzzer go off? Both switches will have to be down for the buzzer or lamp to work.

A completed truth table:

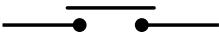
TRUTH TABLE		
INPUT		OUTPUT
A	B	Z
0	0	0
0	1	0
1	0	0
1	1	1

Photocopy the assessment entitled 'Components' on page E29 to give to learners at the end of Week 1.

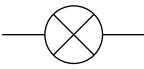
Possible answers

Name	Picture	Symbol	Use
Series battery			This is an input device, source of more energy
Parallel battery			This is an input device, source of more energy
Push switch			Control device used to temporarily close a circuit, for example, a door bell
SPST switch			Control device that opens or closes the circuit
Lamp/bulb			Output device, lights up when current heats up
Bell and buzzer			Output device, vibrates to give off sound when current passes through it, useful as an alarm

ACTIVITY 9 Switches connected in parallel (OR logic) LB p. 105

Group

In this activity the learners will examine the OR switch and discuss it in groups.

Possible answers

If switch A is down or on, it will make the lamp or buzzer go on.

If switch B is down or on, the circuit will work or be working.

When both switches are down the circuit will be on. The learners will discover with the OR logic that switches are attached in a parallel way. This means that any one of the switches can be used to make the circuit work or they can both be on at the same time and the circuit will work. This means that there is always a flow through the circuit once the switch is pushed down.

ACTIVITY 10 Homework LB p. 106

Individual

Encourage the learners to do this task. They can put the circuit together at home. Supply the learners with the materials for this homework activity. You can use a lamp/bulb if you do not have a buzzer. You may allocate marks for this homework task. When they have completed the circuit and shown their peers, the components can be taken apart and reused for other circuits.

Possible answers

Input		Output
A	B	Z
0	0	0
0	1	1
1	0	1
1	1	1

Unit 3.2 Revision of simple circuits

In Grade 7 the learners will have learned about how a current has to flow full circle, like the runner on a track. It is important to know how the current flow as some components can only be connected in a certain way. Even when the learners put cells together they have to be connected in a particular way. Conventional current flows from positive to negative.

ACTIVITY 11 Revision of simple circuits LB p. 106

Group

Divide the learners into groups. Give each group a different circuit to put together. Make sure that each learner in the group has a job to do. Each group will then demonstrate their circuit and give a report back.

Make sure that all the materials are ready before the lesson starts. It is important that time is not wasted sorting out materials. It might work better if the material for each group is placed in a cardboard box or container. Each group will have what is needed for them to build their circuit.

It is important that each group has the same voltage for the different components so that the testing can be compared. The results might not be consistent if the voltage is not the same.

Group 1: A simple circuit with the lamps/bulbs connected in series

Possible answers

The circuit does not work or is not in the 'on' position.

When the switch is making contact, the lamps/bulbs will light up.

Group. 2: A simple circuit with the cells connected in series and the lamps/bulbs connected in series

Possible answers

If you cut the wire all the lamps/bulbs go out.

It will be interesting to listen to the discussion about the Christmas tree lights. Make sure the learners have seen Christmas tree lights. Set up a set of Christmas tree lights for the learners to observe and then loosen one of the lamps/bulbs.

Possible answer

The Christmas lights are connected in series so if one lamp/bulb is faulty they all go off. You have to test all of them to see which one needs replacing.

ACTIVITY 12 Extension LB p. 108

Individual

If there is time and the groups are waiting for the other groups in the class to finish their circuits, they can draw a circuit diagram for their circuit.

Unit 3.3 Ohm's law

Ohm's law qualitatively: as voltage increases, current increases if resistance is constant.

Teacher's tip: Get learners to use an ammeter on their circuits before they get to Lesson 2. Demonstrate how to use an ammeter.

Unit 3.4 Testing Ohm's law

Lesson 2

ACTIVITY 13 Testing Ohm's law LB p. 109

Group

The learners will be testing to see what happens when they increase the voltage (electrical current) on a simple circuit.

Divide the learners into groups. Make sure each learner has a job to do. They must get used to being fully involved because it is what they have to do when doing the Mini-PAT. Each group will build the circuit and then measure the voltage. The group will also demonstrate to the class and give a report back at the end.

Connect the first circuit and note the brightness of the lamp/bulb. Then add an extra cell and note the brightness of the lamp/bulb. When you connected the second cell to the circuit, what happened? When they have connected the third lamp/cell, what happens?

Ohm's law LB p. 110

Explain Ohm's law to the learners. Allow the learners to clarify any of the information presented in class or in the Learner's Book.

ACTIVITY 14 Plotting the graph LB p. 111

Individual

Give each learner a sheet of graph paper (see page E3). Let them paste it in their workbooks and plot the graph to show the relationship between potential difference and the current strength.

The graph should look something like the graph on the next page when the learners have finished plotting it.

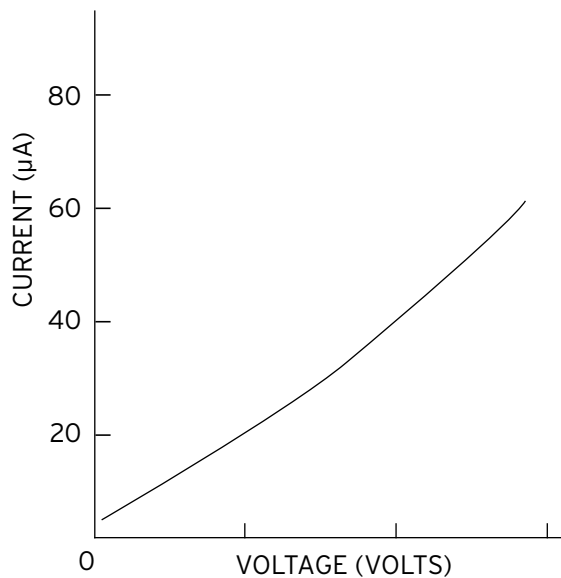

ACTIVITY 15 Calculate values LB p. 112

Group

Show the learners how to use the formulae that relate to Ohm's law and then let them do the activity in their groups. Allow them to compare their answers and explain to each other how they got a particular answer if their answers are different.

Possible answers

1. $V = I \times R$

$$R = \frac{V}{I}$$

$$= \frac{6}{2}$$

$$= 3$$

$$= 3 \text{ ohms}$$

2. $V = 0,4 \times 25$

$$= 10,0$$

Voltage is 10,0 V or 10 V

3. $I = \frac{V}{R}$

$$= \frac{12}{4}$$

$$= 3$$

$$= 3 \text{ amps}$$

4. $R = \frac{V}{I}$

$$= \frac{12}{10}$$

$$= 1,2$$

Resistance = 1,2

5. $I = \frac{V}{R}$

$$= \frac{12}{100}$$

$$= 0,12$$

$$= 0,12 \text{ amps}$$

$$\begin{aligned} 6. \quad V &= I \times R \\ &= 1000 \times 0,01 \\ &= 10 \\ &= 10 \text{ V} \end{aligned}$$

Unit 3.5 Resistors

Week 2

In Week 2 you will cover resistor colour codes and calculating the values of the resistors.

What you will need for Week 2:

- a variety of resistors
- some small toys and items that use resistors.

Lesson 3 LB p. 113

Resistor colour codes

In this lesson the learners will look at resistors, which can be used to control the flow of electricity. A resistor opposes the flow of electricity but it also protects components.

Teacher's tip: Resistors are not expensive but they are small so store them in a well-marked box. A see-through plastic container will be the best. The learners can then see what is in the container.

Distribute the resistors you have brought to class to learners. Let them look at the resistor and recognise how the colour bands differ from resistor to resistor.

Read through the information in the Learner's Book and talk about the purpose of resistors.

Let the learners practise drawing the resistor symbol in their workbooks.

Low and high value resistors

Calculate the values of some sample resistors.

ACTIVITY 16 Homework LB p. 116

Individual

See if the learners are able to connect resistors in series and in parallel. They should bring the circuit back to school to show the class. Give them marks for the effort.

Lesson 4 LB p. 116

ACTIVITY 17 Estimate values LB p. 117

Group

Let the learners talk about how to calculate the resistance of a resistor. Explain how the table can assist them to determine the resistance. Let them look at the resistors on page 117 in the Learner's Book and estimate the resistance. Please note that these will not be accurate, as the bands of the resistors in the pictures are not always clear enough.

ACTIVITY 18 Calculate resistance LB p. 117

Group

Give some resistors to the learners and ask them to calculate the resistance values.

Self-assessment LB p. 118

Let the learners work through the self-assessment checklist. If particular learners identify anything that they are still having difficulty with, address the problem areas with them.

Unit 3.6 Components

Week 3

During this week the learners will cover switches, diodes, LED transistors and sensors.

What you will need for Week 3:

- a variety of electronic components
- NPN transistors
- resistors
- LDRs (light dependent resistors)
- thermistors
- touch or moisture detectors
- LEDs (light emitting diodes)
- polarised capacitors
- unpolarised capacitors
- voltmeters
- ammeters
- a variety of items using different switches
- push switches
- slide switches
- toggle switches
- rocker switches.

Lesson 5 LB p. 118

Enlarge the table showing the electronic components on pages 118 and 119 in the Learner's Book and make it into a poster for the wall.

Remedial tip: Make the poster colourful, with big illustrations. The dyslexic learner will remember the visual rather than the words. The illustrations with the words in different colours or highlighted will help the learners associate the picture with the word.

ACTIVITY 19 Switches LB p. 121

Class

Collect different types of switches for the learners to touch and use. Often a scrap merchant, second hand shop or electrical shop will sell different switches. It is important that the learners see how the switches work.

ACTIVITY 20 Diodes and LED LB p. 122

Group

Remedial tip: Store the components in different boxes that are well labelled with big printed words so that the learner can associate the work with the actual component.

Let the learners examine the LEDs that you have brought to class.

Lesson 6 LB p. 122

Transistors

Let the learners copy the transistor and its circuit symbols into their Technology workbooks.

ACTIVITY 21 Transistors LB p. 124

Group

Only NPN transistors will be used at this level. Connect a simple transistor circuit.

Week 4

During this week the learners will cover simple electronic circuits with different components. They will look at different sensor devices.

What you will need for Week 4:

- Sensors
- LDRs
- thermistors
- touch or moisture detectors

- motors
- solenoids (6 V)
- counters (6 V)
- relays
- capacitors
- soldering iron
- insulated wire
- batteries
- transistors.

Lesson 7

ACTIVITY 22 Sensors LB p. 125

Pair

Let the learners do this activity with a partner and then allow them to give feedback to the class about their discussion.

LDRs are used in light sensing applications such as alarm devices, street lights and camera light meters.

Lesson 8

ACTIVITY 23 Thermistors LB p. 126

Pair

Help the learners identify where one might use a thermistor.

Thermistors are used to limit current in devices that could overheat, for example, they monitor the temperature of battery packs while charging, and in toasters, coffee makers, refrigerators and hair dryers.

ACTIVITY 24 Homework LB p. 126

Individual

Remind the learners to be careful when working with tools like soldering irons. If they need assistance when building and testing the circuit, they should ask a responsible adult at home to assist when doing this homework.

Let the learners assemble the circuit and try it out. They can heat up the thermistor by holding a soldering iron close to it or something similar.

ACTIVITY 25 Touch or moisture detectors LB p. 127

Pair

Let the learners share with the class why it is important to use a 'bare' wire for the sensor.

The wires must be bare so that the circuit may be closed.

ACTIVITY 26 Homework LB p. 127

Individual

Let the learners build the circuit and record their findings. Find time in class to discuss the findings.

If there are learners whose circuits are not working, remind them about common faults that might occur. One of the things to do is to check that the voltage of the device and the battery match.

ACTIVITY 27 Extension LB p. 128

Individual

If there is time, let the learners build a touch moisture detector by making a probe from an etched circuit probe. Let some of the learners who build the touch moisture detector demonstrate their circuit to the class.

ACTIVITY 28 Capacitors LB p. 128

Pair

Let the learners share their discussions with the rest of the class.

Capacitors are used in car audio systems, and very strong capacitors are used in electric cars.

Self-assessment checklist LB p. 128

Ask the learners to write the answers to the questions in their workbook. Make sure that all the learners understand the work to date. Take time to teach the learners who are struggling in certain areas.

Unit 3.7 Simple electronic circuits

Week 5

The learners will cover simple electric circuits.

What you will need in Week 5:

- LDRs
- LEDs
- thermistors
- transistors
- NPN transistors
- buzzers

- bells
- variable resistors
- 1 kohm resistors
- 6 V series batteries
- insulated wire
- lamps/bulbs
- lamp/bulb holders
- touch or moisture detectors
- capacitors
- 470 ohm resistor
- 4,5 V series battery
- 3 V series battery
- DC power supply or photovoltaic panels
- 1000 μ F capacitor switches
- wood
- circuit board
- cardboard
- glue
- pliers
- saw
- scissors
- pencils
- rulers
- erasers
- wire cutters.

Lesson 9 LB p. 129

ACTIVITY 29 Draw and assemble simple electronic circuits LB p. 129

Group

Assign each group to the Group 1 or Group 2 activity.

Group 1

Make sure the learners check that they connected the LED the correct way.

Group 2

Make sure the learners check that they connected the LDR the correct way.

Once they have assembled the circuit, they must cover up the circuit slowly with their hand and observe what happens.

Let them try using an LED, 470 ohm resistor, switch, and 4,5 V series battery. They can then try building a circuit using an LDR, buzzer and a 3 V series battery.

Formal Assessment Task: Mini-PAT 3 LB p. 131

Topic: Innovation – Electronic systems and control

Content: Design and make a working circuit

Scenario: These are the specifications you will help the learners discuss.

Lesson 10

Scenario 1

Design a light for each end of a section of roadworks that can be switched on at each end. The learners must use a circuit that they have adapted from one they have already worked with.

Here are some criteria the learners may want to use:

- The structure must be neatly made and it must be stable.
- The circuit for the OR circuit must be hidden in the model with only the switches showing. The circuit should be visible for assessment and repairing.

Or

Scenario 2

Design and make a quiz game that will enable learners to study Technology in a fun way. Here are some criteria the learners may use for their project:

- It must have a strong structure to display the quiz game on.
- It must use an AND circuit.
- The learners may adjust the circuit diagram they have been given slightly to be more creative and to suit the quiz game.
- The circuit should be hidden neatly underneath with only the probes that will work the game showing.
- The circuit must have a light or a buzzer that goes off when the answer is correct.
- It must have questions and answers that apply to Technology.
- It must have at least two different surfaces with questions.
- The game must be colourful and creatively decorated.

Or

Scenario 3

Design and make a device with two switches. If both switches are not operated simultaneously, a buzzer or bell will go off. Here are some criteria the learners may use for their project:

- It must use an AND circuit.
- The learners may adjust the circuit diagram they have been given slightly to be more creative and to suit the box.

Remedial tip: Learners with reading and learning difficulties will find the written part of the design process difficult. It is important

that you help by placing these learners in suitable groups where they will be helped. Allow these learners to write short sentences in their workbooks. Do not mark them on their spelling but rather on the work they produce. Encourage them to come to you for the spelling of the more difficult words, or put some of the words onto a chart or the chalk board. Make sure you use different colour chalk or colours and also make the print large.

Week 6

The learners will cover appropriate circuits and start the design brief.

What you will need for Week 6:

- All the materials the learners have been collecting to build their final circuit.

Lesson 11 LB p. 134

ACTIVITY 30 Investigation LB p. 134

Group

Investigate the situation and the nature of the need so that an appropriate circuit can be chosen to solve the problem, need or want given in the scenario. A given circuit must be incorporated into the design of a device that will use electronics to address the problem, need or want.

Before the learners start their design let them think of the following questions:

- What do they need for their design?
- What will it do?
- Who will use it?
- What will it be used for?
- Where will it be used?
- What features must it have to work properly?
- What materials can be used?
- What will it be made of?
- How will it work?
- What would it look like?
- How big should it be?

The learners must remember that this will also be part of their criteria for assessing the end product.

Let the learners list the tools and materials they are going to use.

Lesson 12 LB p. 135

ACTIVITY 31 The design brief and sketches LB p. 135

Individual

Before the learners start the design brief make sure they have rulers, pencils and all the other stationery they need.

The design brief

Each learner writes his/her suggestion for the design with specifications and constraints.

Each learner draws the circuit diagram.

Each learner produces a sketch in 3D showing the device that will use the electronic circuit. Teams meet and examine the individual suggestions to decide on a final solution. Make sure that the learners are able to have a discussion. Walk around the classroom to help with the discussions.

Tip: Go through the checklist with the learners. Some learners get anxious and forget basic things.

Make sure they have the right equipment.

Ensure that the work is fairly divided up amongst the members of their team. Remember that they will be assessed for their contribution to the task as well as being assessed as a team.

They will be required to fill in an assessment of the other teams' models and presentations.

Explain to the learners what DC stands for – direct current.

Self-assessment checklist LB p. 136

Let the learners work through the checklist. Address any problems they may have.

Week 7

This week you will cover plans and the making of the device or model.

What you will need for Week 7:

- Continue to collect all the materials to build the final circuit.

Lesson 13 LB p. 136

ACTIVITY 32 Design, sketch and produce LB p. 136

Group

The learners will produce plans for their device/model/prototype using first angle orthographic projection. They will use all the knowledge they have gained to draw the design. The plans should include a 3D

‘assembly’ drawing in exploded view showing how the model fits together.

Each team member draws a working drawing of the design or an aspect of the design.

The device/prototype/working model must showcase a viable solution to the problem. It should be to scale and net, and show intelligent use of available materials.

Lesson 14 LB p. 137

ACTIVITY 33 Produce LB p. 137

Group

Let the learners continue producing their model and drawings.

Week 8

The learners will present their projects this week.

What you will need for this week:

- Presentation material

Lessons 15 and 16

ACTIVITY 34 Communication - team presentations LB p. 137

Group

Each team is given five minutes to present their solution in the form of sketches, artistic impressions of the solution, working drawings/ plans, costing, and their model.

Photocopy this rubric (on page E6) for the learners to assess the other groups and even do a self-assessment. They can also add more to the rubric if they like. Each team will need the rubric filled in by the other groups. See the levels of effectiveness table on page E7.

Self-assessment checklist LB p. 137

Let the learners complete the self-assessment. Assist the learners in resolving any particular problems they may be experiencing.

Week 9

In Week 9 each learner will compile a record of their own individual contribution to the task. They will record this in their workbooks. This recording will be done over the two hour lesson for the week.

Lessons 17 and 18

ACTIVITY 35 Record of individual contribution LB p. 138

Individual

Each learner compiles a record of his/her own individual contribution to the task. It should be reflected in each learner's workbook.

Self-assessment checklist LB p. 139

Let the learners complete the self-assessment. Remind them to be truthful so that their assessment is a true reflection of the work they have done.

Week 10

The learners will write an assessment. You may use the assessment (on page E30) as we have created it or you may use this as a basis to create your own assessment to suit your class.

4

TERM

During this term you will be focusing on the following concepts and skills: the preserving of metals through painting, galvanising and electroplating, the preservation of foods by storing, pickling and drying and/or salting. Learners will investigate the different properties of plastics, their uses and ways to reduce, re-use or recycle them. They will make a plastic product that will satisfy a need, want or opportunity.

Unit 4.1 Preserving metals

Week 1

A week's work will be covered in two one-hour lessons. At the end of each week, the learners will do a self-assessment or peer assessment task to revise the work you have covered in the two hours.

This week learners will learn about what metals are, their various uses and ways to preserve metals by painting and galvanising. If you have time, you can do an extension activity on platinum mining in South Africa.

What you will need for Week 1:

- vinegar
- salt
- copper wire
- large container
- battery
- sticky tape
- two pieces of metal – one copper and one nickel.

Ensure that you have all the materials and tools for the activities during the week. Conduct the activities and experiments yourself beforehand so that you are better prepared to assist learners who are struggling.

Lesson 1 LB p. 142

Read through and discuss the information on the preservation of metals.

ACTIVITY 1 Preserving metals LB p. 147

Individual

Ask the learners to answer the questions in their Technology workbook under the following heading: **Preserving metals.**

Possible answers

1. Metals are found in all rocks and soils and are elements that are good conductors of heat and electricity.

2. In cars, trucks, buses, ships and aeroplanes. In aerospace (rockets and the space shuttle), in computers and electronic devices that require conductors (TV, radio, stereo, calculators, security devices, etc.). For communications, food processing and preservation (microwave and conventional ovens and refrigerators and freezers), construction (nails in conventional lumber construction and structural steel in buildings), biomedical applications (as artificial replacement for joints and other prostheses), electrical power production and distribution (boilers, turbines, generators, transformers, power lines, nuclear reactors, oil wells and pipelines), farming (tractors, combines, planters), household appliances (ovens, dish and clothes washers, vacuum cleaners, blenders, pumps, lawn mowers and trimmers, plumbing, water heaters, heating/cooling appliances).
3. Corrosion of metals occurs when oxidation takes place, which generally happens in the presence of water and oxygen. Rust is the most common form of oxidation.
4. Open ended – any metal that that does not have a protected coating on it will rust,
5. Open ended – repainting metals structures when rust occurs, washing a car after you have been driving along the coast to wash off salt that causes rust, electroplating, etc.
6. Electroplating and galvanising.
7. The condition of the metal structure, the type of metal, the life expectancy of the metal and the environment in which the structure is used.
8. An example of a simple flow diagram to show the galvanising process.

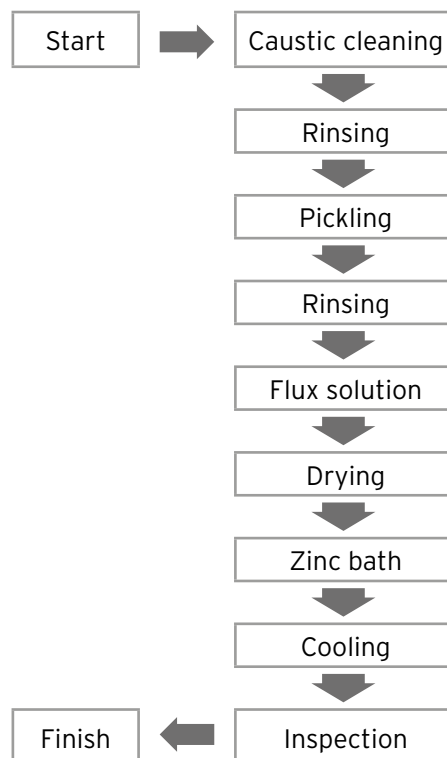

ACTIVITY 2 Extension LB p. 148

Individual

South Africa is one of the largest producers of platinum and accounts for almost 80% of the world's platinum production.

1. Find out where the platinum mines are situated in South Africa
2. Find out what platinum is used for.
3. South Africa came under international spotlight because of the Marikana Platinum Mine strike in August 2012. Find out more about this strike and write a paragraph about it.

Guide learners who are struggling to find the information on where to do research. Check that the learners have completed their tasks.

Lesson 2

Talk about the lesson expectations, ground rules, what electroplating is, the process of electroplating, resources and equipment needed and safety issues.

ACTIVITY 3 Electroplating LB p. 148

Group

Let the learners read through the instructions on how to conduct the experiment. Let them work safely to electroplate a metal. Assist those learners who are struggling.

Self-assessment checklist LB p. 149

Let the learners complete the self-assessment rubric regarding electroplating.

Unit 4.2 Indigenous technology: Preserving food

Week 2

The class will learn about indigenous technology that can be used to preserve grain and how to preserve fruit or vegetables by pickling.

What you will need for Week 2:

- a variety of preserved foods (to show)
- ingredients as listed in the recipe
- chopping board
- storage jars
- dish cloth
- knife
- apron, cap, gloves (optional)
- bin bag.

Lesson 3 LB p. 150

ACTIVITY 4 Preserving grain LB p. 151

Individual

Let the learners answer the questions in their Technology workbooks.

Possible answers

1. Grain kernels that come into contact with the damp clay begin to ferment. This releases carbon dioxide gas (CO_2) into the sealed grain pit, which prevents **bacteria** and **fungi** from developing.
2. The pit is still filled with carbon dioxide gas, which is poisonous to people. The pit needs to be left open for a few hours to allow the carbon dioxide gas to be released so the child can breathe when lowered into the pit.
3. It comes into contact with the damp clay.
4. A system diagram to represent the indigenous preservation system used by the Nguni people.

System diagram showing the preservation of grain using grain pits

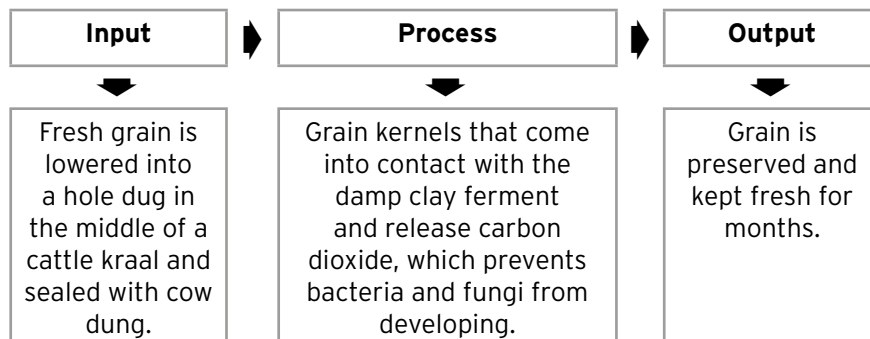

Set aside the last ten minutes of the lesson for a discussion planning session for Lesson 4, which is a practical lesson. Allocate the learners to groups to plan resources needed for the next lesson. Give each learner an assessment rubric to be used in Lesson 4 so that they can plan according to criteria to be used.

Important reminder: Remind learners to bring resources and equipment needed for Lesson 4 and to have a back-up plan for learners who may forget.

ACTIVITY 5 Pickles from around the world LB p. 152

Individual

Let the learners see if they can identify each of the different types of pickles and state which country is famous for each. Let them write their answers in their Technology workbooks under the heading: Pickles from around the world.

Possible answers

A	B	C	D	E	F
Mexico	India	China	Japan	Scandinavia	Iran
Pickled Jalapeno	Achar	Picked Red Chinese cabbage	Gari - Pickled ginger	Pickled Salmon	Torsi

ACTIVITY 6 Homework LB p. 153

Individual

Let the learners list as many examples of how the types of food illustrated on pages 155 and 156 may be preserved. A wide variety of answers may be accepted and may include drying, salting, freezing and canning.

Important reminder: Your next lesson will be a practical lesson. The learners will work in groups to preserve food by drying or salting. Remind them to bring all the resources needed for this lesson.

Lesson 4

ACTIVITY 7 Preserving food by drying/salting LB p. 154

Group

Let the learners read through the instructions for the practical activity. Let at least two people in the group check the list of requirements. Talk about the ground rules when conducting the practical activity. Share helpful hints and remind learners about hygiene and safety issues when working with food. Give each learner a copy of the rubric that will be used to assess this activity.

The drying/salting process takes time, allow time for the food to be preserved using the method chosen and set a date for when this will be assessed.

Assess the learners' practical activity using the assessment rubric for the preservation of food.

ACTIVITY 8 Extension LB p. 155

Group

Let the learners arrange a market day to sell the preserves they made or arrange to donate the preserves to a needy organisation.

Suggestion: This can be assessed in Lesson 14 together with the product made from plastic and the learner's portfolio.

Unit 4.3 Processing plastic

Week 3

The focus this week is on the different types of plastic and their uses. The learners will also learn how to identify and sort plastics for recycling according to codes.

What you will need for Week 3:

- a variety of products made from different types of plastic
- copy of the plastics table to complete.

Lesson 5 LB p. 155

Conduct a discussion about what plastics are and how to identify plastics using SPI codes.

ACTIVITY 9 Types of plastic LB p. 156

Individual

Give each learner a copy of the ‘Types of plastics’ table to complete.

ACTIVITY 10 Investigating different types of plastic LB p. 157

Individual

Give each learner a recording sheet to record the material that is being recycled.

This is an awareness activity. Use this task to educate learners about the importance of recycling. Discuss why these plastics should be recycled instead of landing in landfill sites. Recap the need to recycle.

Lesson 6 LB p. 157

Learners learn about types of plastics and their uses and using SPI codes to identify different types of plastic. Let them talk about the properties of plastics, thermoplastics and thermosetting plastics, recycling of plastic waste products and closed loop recycling.

ACTIVITY 11 Properties of plastic LB p. 159

Individual

Read the table and answer the questions follow. Write your answers under the heading: Properties of plastic in your Technology workbook.

Possible answers

1. Low density polythene (polyethylene)
2. Durable outdoors, more impact resistant
3. Expanded polystyrene – it is heat resistant
4. Nylon
5. Stiff, hard, tough at room temperature, light weight –any two
6. Splinters easily, scratches easily
7. Plasticised PVC
8. Polyester resin
9. Polyester resin – good resistance to heat, resistant to ultraviolet light
10. Nylon

Self-assessment checklist LB p. 162

Sign the self-assessment checklist in the learners' Technology Workbooks.

Unit 4.4 Re-use of waste plastic

Week 4

This week the learners will learn about remanufacturing waste plastic into pellets for re-use and draw a flow diagram.

What you will need for Week 4:

- PETCO movie.

Lesson 7 LB p. 163

Let the learners read through the case study. Help to clarify anything that is unclear to them.

ACTIVITY 12 Systems diagram LB p. 165

Individual

Read and discuss the case study in groups and draw a simplified systems diagram showing the process involved in the manufacture of recycled plastics. Label your systems diagram: Manufacturing waste plastic into pellets for reuse.

Possible answers

See the next page for a systems diagram showing the manufacturing of waste plastic into pellets for reuse.

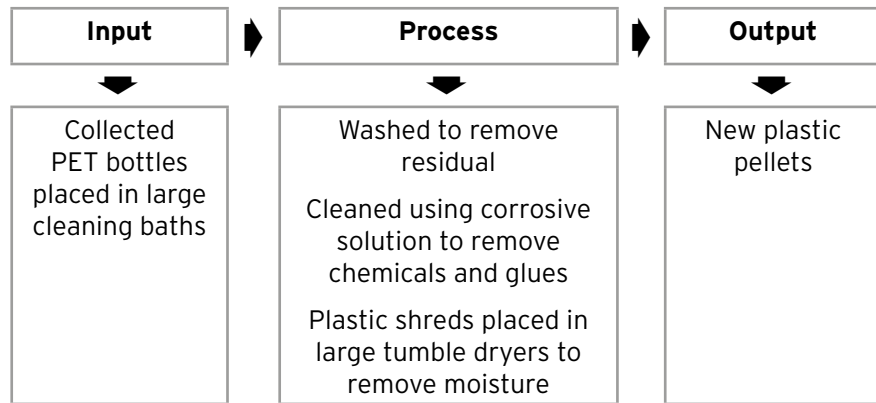

Or

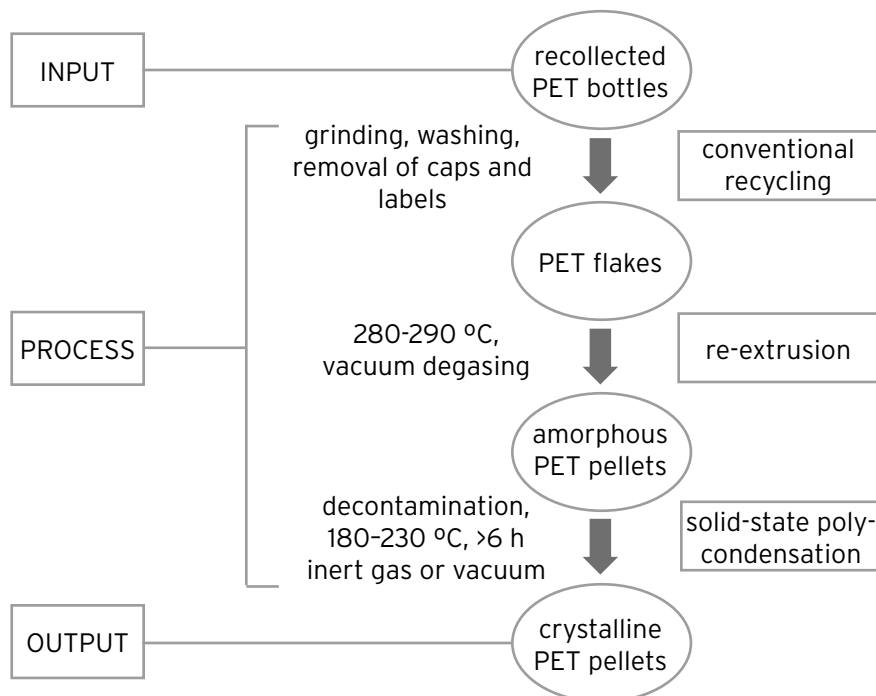

Check the learners' systems diagrams while they work and correct errors.

Lesson 8 LB p. 165

Learners learn about remanufacturing waste plastics into pellets for reuse

ACTIVITY 13 Case study 2: Moulding recycled plastic pellets into products LB p. 165

Group

Let the learners read through the case study. Explain anything that is unclear to them. Let them draw a systems diagram labeled: Moulding recycled plastic pellets into products.

ACTIVITY 14 Questions about moulding recycled plastic pellets into products LB p. 167

Individual

Let the learners answer the questions in their Technology workbook.

Possible answers

1. Accept learners list of products and packaging made from PET plastics
2.
 - a) Community members: Provide a livelihood for community members – encourages people to recycle, earn a living by selling recycled plastics to recycling companies, people make a living by recycling waste products from landfill sites
 - b) Packaging companies: lower cost of the manufacturing of new packaging – helps in keeping with company policy of being responsible for the end product of product that they manufacture – ‘Cradle to Grave’ Policy
 - c) the Department of Environmental Affairs: Less money being spent on clean-up operations, less waste for landfill sites
 - d) The environment: Less damage caused to the environment by non-biodegradable materials
3. Blow moulding is when a melted polymer material is placed into a mould and air is injected into the cavity, which pushes the polymer into the desired shape. Compression moulding is when a polymer is placed on the bottom half of a compression mould and the top half is lowered onto the bottom half, pushing the polymer into the desired shape.
4. Carpet companies use recycled resin to make polyester carpets. Recycled plastic pellets are used in the textile industry to make clothing, jackets and polar fleeces. Manufacturers of VCR and audio cassettes use pellets from PET bottles to make clear sheets or ribbon for VCR and audio-cassettes. Spunbond is used to create geotextiles, which are used in roof insulation or as a means of combating soil erosion. Engineering companies use engineering plastics, pumps, gears and chemical-resistant components made from recycled plastic pellets. Industrial manufacturers make strapping tapes, magnetic tapes on smart cards, X-ray film, cigarette filters and tennis ball felt from recycled plastic pellets.

ACTIVITY 15 Extension LB p. 167

Class

Contact PETCO and arrange to have a copy of their movie on recycling sent to you to share with the learners.

Week 5

The learners will look at more case studies dealing with the use of plastics in cars and in the home. They will also start planning for their practical activity.

Lesson 9 LB p. 168

Formal Assessment Task: Mini-PAT 4

Case study 3: Plastics used in modern motor cars LB p. 169

Let the learners read through the case study. Allow time for a class discussion about the different ways in which plastic is used in the production of cars. Encourage them to look at cars and to identify the parts made of plastic.

Lesson 10 LB p. 172

Ask the learners to identify instances in which plastic is used in the home. Let them read Case study 4: Lighting the way with plastic bottles.

ACTIVITY 16 Extension LB p. 173

Individual

Let the learners watch the video on the Internet.

ACTIVITY 17 Using plastic LB p. 173

Individual

Let the learners read the case studies about plastics used in modern motor cars and in the home and complete the table in their Technology workbooks under the heading: The different uses of plastic in motor cars and around the home. Provide your own reasons where necessary.

1.

	Item	Reason the item was manufactured from plastic
1	Plastic food wrap	Airtight - keeps food fresh
2	Cordless phones	More durable, will not shatter if dropped
3	Large appliances	Resists corrosion
4	Rubber stoppers under chairs	Plastic absorbs sound and will not scratch other surface areas
5	Plastic on appliance plugs	Plastic is an insulator and will not conduct electricity
6	Body parts of the Smart Car	Light and easy to interchange panels, more scratch resistant
7	The ZR Supercharged Corvette-Hood	Reduces weight and allows you to see the engine

	Item	Reason the item was manufactured from plastic
8	Synthetic polyurethane leather door treatments	Has the same look and feel as leather, aesthetically pleasing and more affordable
9	Plastic hollow air bags	Deploys more rapidly
10	Bumper fascia	Less damage caused in the event of a collision, bumper is light and can be easily removed and replaced

- Let the learners write a paragraph on the use of plastic bottle daylighters being installed on roofs of informal shelters in South Africa.

Check whether the tables have been completed. Help learners identify reasons if there are gaps in the table.

ACTIVITY 18 Problem identification LB p. 174

Group

Use the knowledge that you have gained to identify a need or want that can be satisfied by the making of a plastic item of your own design.

Let the learners discuss the questions in groups. Let the learners complete the following written activity in their technology books:

ACTIVITY 19 Homework LB p. 175

Individual

Ask the learners to complete the tasks on sheets of exam paper and file them in their Technology Portfolio under the heading: Task 1: Identification of the problem that needs to be solved. This work needs to be included in with their Technology Portfolio for an assessed mark at the end of the year.

Important reminder! Bring your resources for your practice lesson in Lesson 12.

Week 6

This week learners will practice their design skills by sketching using isometric projections and first angle orthographic projections. They will also practice the skills required for making their product.

What you will need for Week 6:

- isometric grid paper
- resources and equipment as per design
- safety gloves
- multi-cutters
- bin bag
- pliers
- hammer
- a good adhesive glue to join plastic.

Lesson 11 LB p. 176

ACTIVITY 20 Isometric projections LB p. 176

Individual

Give each of the learners an isometric grid to do draw their 3D design. This activity must be included in the learner's Technology Portfolio for a mark at the end of the year.

Assess the drawings using an assessment rubric for isometric drawings.

ACTIVITY 21 First angle orthographic projection LB p. 178

Individual

Let the learners draw their design in first angle orthographic projection. This activity must be included in the learner's Technology Portfolio for a mark at the end of the year.

Assess this drawing using the assessment rubric for first angle orthographic drawing.

Important reminder! Remind the learners to bring their resources for the practice lesson in Lesson 12 and the practical lesson in Lesson 13.

Lesson 12 LB p. 179

ACTIVITY 22 Skills development LB p. 179

Group

Discuss the task. Make sure all members are aware of their responsibilities. Let them practise measuring, marking, cutting, bending and joining skills which will be needed in Lesson 13.

Important reminder:

Remind learners to bring the resources and equipment needed for Lesson 13.

Week 7

During this week the learners will make their product. They must also hand in their Technology Portfolio.

Let the learners use the checklist to ensure that their Technology Portfolio is complete.

Lesson 13

ACTIVITY 23 Practical LB p. 180

Group

Learners work in groups to make a plastic product that will satisfy a need or a want. Remind learners to work safely when making their product. Remind them that this is an assessment task.

ACTIVITY 24 Extension LB p. 180

Individual

Arrange to donate your plastic item to a needy organisation.

Lesson 14 LB p. 182

ACTIVITY 25 Practical assessment LB p. 180

Group

Assess the learners when they present their completed product together with their Technology Portfolio. You may allow learners to do a presentation to the rest of the class if time permits.

Learners hand in their Technology Portfolio consisting of tasks needed for assessment purposes.

Week 8

The summative year end examination.

All work covered will be examined. The understanding of the knowledge the learners have gained and their application of this knowledge will be examined. Identify any areas of concern and assist learners to address these areas of concern.

Section E: Photocopiable resources



This part of your Teacher's File is for storing all photocopiable templates, worksheets and resources that are provided and that you may come across in your planning and research.

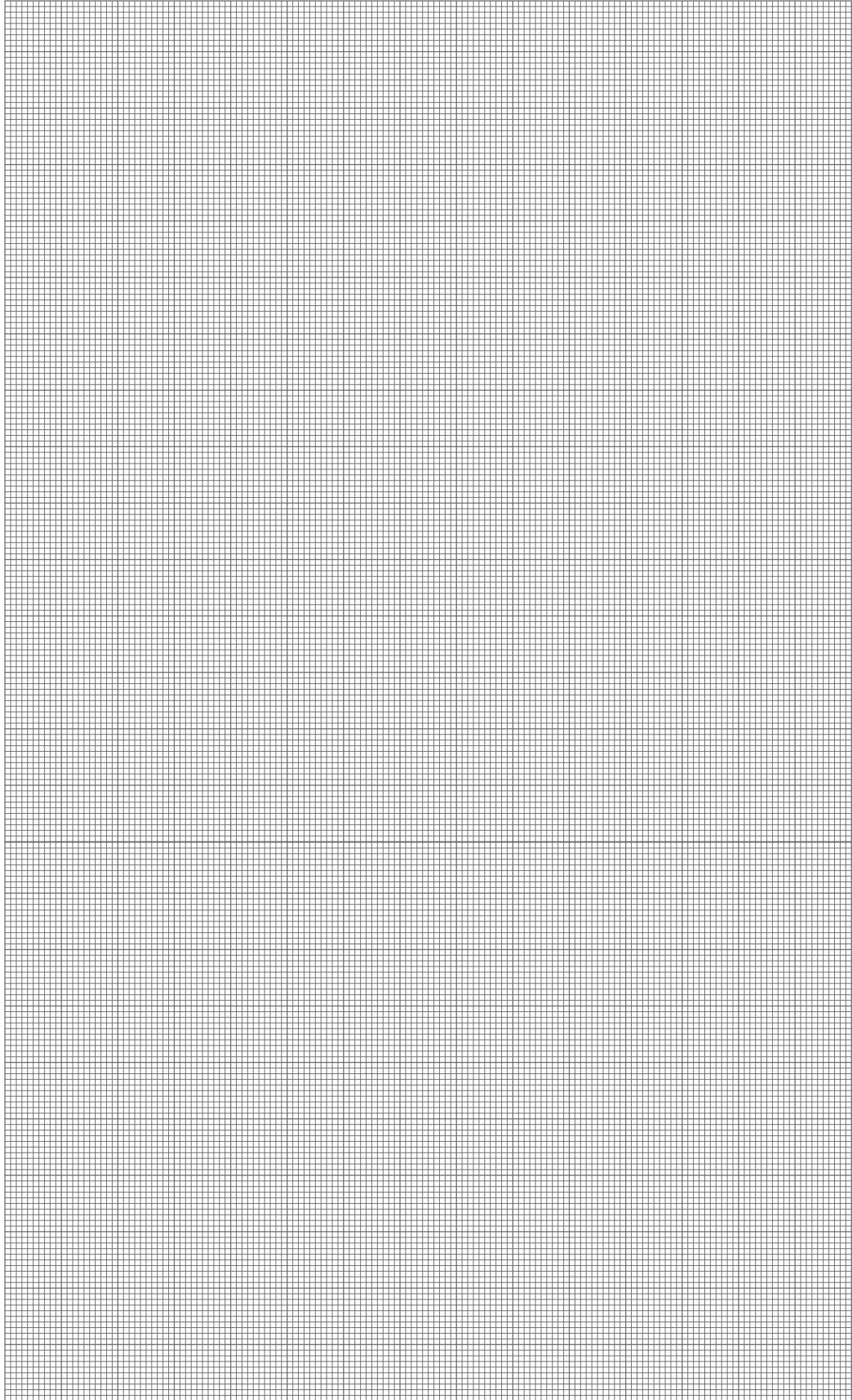

Grid sheet

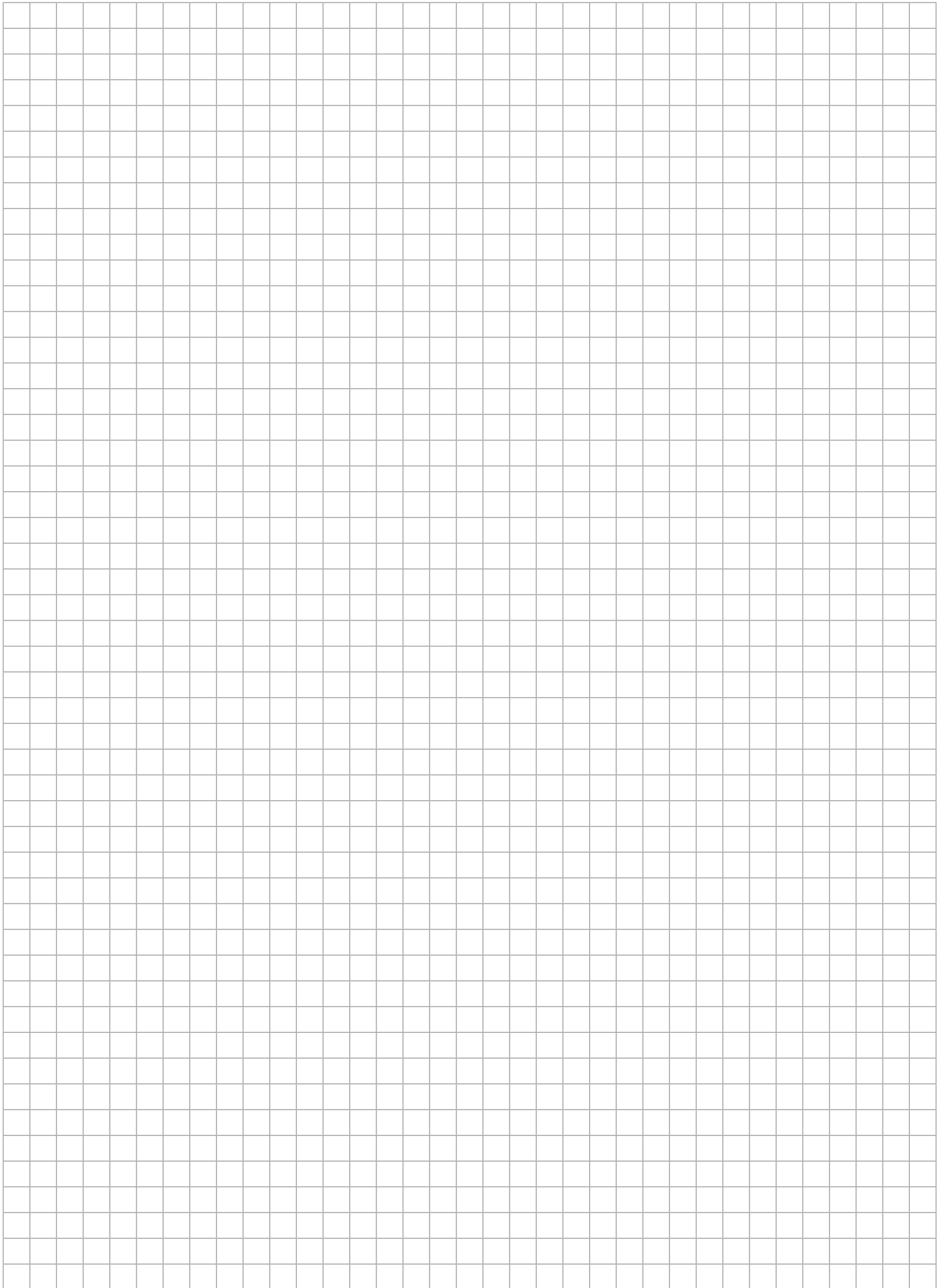

Isometric grid sheet

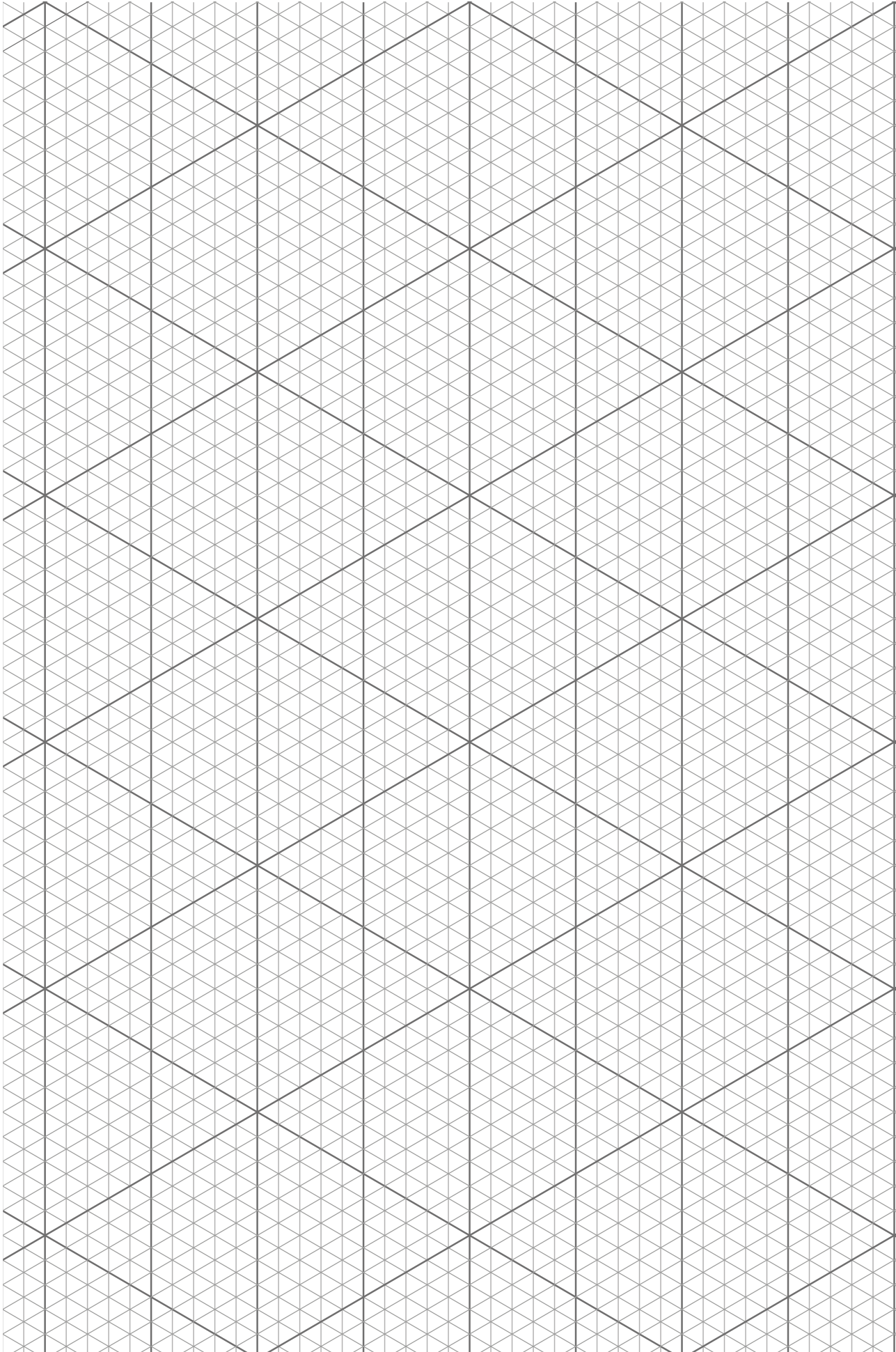

Graphic communication as a design function

<p>OUTCOME: The learner must be able to communicate design ideas. Self-assessment Complete the checklist to determine if the following requirements are present.</p>		
I have presented:	Yes	No
sketches of different design solutions to communicate my ideas		
labelled sketches to clarify detail relating to the design brief and specifications/ constraints		
developed the selected idea as a freehand sketch to show more detail		
formal drawings e.g. orthographic first angle projection		
formal drawings e.g. orthographic third angle projection		
formal drawings e.g. isometric view		
formal drawings e.g. oblique view		
formal drawings e.g. exploded view		
sequenced drawings, such as flow diagrams or flow charts, for the making process		
dimensions and quantities of materials		

Graphic communication as a demonstration of technical skills

<p>OUTCOME: The learner must be able to apply appropriate formal drawing techniques when designing: Self-assessment Complete the checklist.</p>		
The following aspects are present:	Yes	No
SABS convention for: scale line types dimension lines		
Enhancement of sketches colour texture shade thick lines thin lines shadow		
Orthographic drawings (2D drawings) first angle orthographic projection third angle orthographic projection correct axis		
Isometric drawing (3D drawing) correct axis is used line quality is correct		
Oblique drawing (3D drawing) correct axis is used line quality is correct		
Perspective sketches (3D drawing) correct axis is used line quality is correct		
Exploded views Correct axis is used Line quality is correct		
Sequence drawings		
Circuit diagram		
Systems diagram		

Levels of effectiveness

Group: (Names of learners)					
	4	3	2	1	Comment
Investigates					
Understands the problem context					
Produced sequenced notes when making the model					
Able to manufacture the model according to the design brief					
Communicates					
Communicated ideas clearly in presentation					
Explained their role clearly in presentation					
Has developed a working drawing					
Contributes					
Contributed to the decision making and discussions in the team					
Used the portfolio to communicate technological process					
Understands					
Understands knowledge and concepts Is able to use and apply research findings on different circuits and components					
Identifies the problem					
Follows through on ideas that have been developed in a logical way					
Is able to solve the problem by applying the technological process correctly					
Designs					
Has contributed towards the design proposed by the team					
A variety of creative options were explored					
Makes					
Worked neatly and safely when using tools					
Made a list of resources needed					
Made of cheap or readily available materials					
Circuit worked properly to suit the need					
The model was strong enough					
Able to bear in mind all the specification when making the product					
The model was well built, attractive					
Evaluates					
Able to evaluate their own model, drawing and presentation					
Able to evaluate peers' models, drawings and presentations					
Planning					
Stuck to constraints					
Participated in preparing joint strategy for presentation					

	4: highly effective	3: most areas are effective	2: some areas are effective	1: not effective
Investigate	There is evidence of an excellent understanding of important ideas	A good understanding of important ideas	Some relevant ideas were considered	Ideas were not appropriate
Communicate	Product followed design brief and specification	Good interpretation of design brief and specification	Incomplete interpretation of design brief and specification	Product differed widely from design brief and specification
	Ideas clearly and accurately presented	Good presentation of ideas	Ideas were muddled and presentation was average	Presentation was poor, ideas were not clear
	Excellent contribution to discussions	Good contribution to discussions	Little contribution	No contribution
	Portfolio highly organised and well planned	Portfolio organised and planned	Poorly documented and incomplete	Incomplete, little effort, inaccurate
Knowledge	In depth knowledge of electrical and electronic circuits	Good knowledge of electrical and electronic circuits	Understands circuits with assistance	No understanding
Problem identity	Excellent follow through on logical ideas	Good follow through on logical ideas	Needs assistance to follow through ideas	Unable to follow through ideas
	Applies technological process correctly	Good application	Needs assistance with application	Process incorrectly applied
Design, execution of poster, etc.	Excellent visual appeal, bold lettering, excellent use of colour, shading	Good visual appeal, fair size lettering, good use of colour, shading	Some visual appeal, lettering poor, some use of colour and shading	Little visual appeal, poor lettering, poor use of colour and shading
	Variety of creative options	Good creative options	Some creativity	Little or no creativity
Makes	Used tools safely	Mostly safe usage	Some safety aspects considered	Ignored safety aspects
	All resources and tools listed	Most resources and tools listed	Some resourced and tools listed	Few resources and tools listed
	All specification followed	Most specification followed	Some specification followed	Few specifications followed
	Good workmanship, attractive	Acceptable quality, quite attractive	Errors in workmanship	Product incomplete, not good workmanship
Evaluates	Product and process evaluated, recommendations made	Good evaluation	Either product or process evaluated or both done ineffectively	Product and process lack evaluation
	Peer product and process evaluated, recommendations made	Good peer evaluation	One or both ineffective	Both lack evaluation
	Excellent strategy planning	Good strategy planning	Some good ideas, but rather haphazard	No strategy planning

Module 1: Unit

Tender application for registration

Msunduzi

Municipality

CITY OF CHOICE

PIETERMARITZBURG

M S U N D U Z I

Suppliers Database Registration Form

Registration forms are to be delivered to:

The Msunduzi Municipality, Procurement Unit, 5th Floor, AS Chetty Building,
333 Church Street, Pietermaritzburg or Private Bag X205, Pietermaritzburg, 3200
Attention: The Procurement Manager

Enquiries

Telephone: 033-392 2486 or 392 2853

For office use

Supplier name _____

Date application received _____

MSU Number MSU _____

Supplier information captured by _____

APPLICATION FOR REGISTRATION ON THE MSUNDUZI MUNICIPALITY SERVICE PROVIDERS DATABASE

1.0 BUSINESS PARTICULARS

1.1 Name of business as registered with the Registrar of Companies/Close Corporations. _____

1.2 Name of business used for TRADING purposes. If different from 1.1 or name of business if business is not registered with the Registrar.

1.3 Registration number as registered with the Registrar of Companies/Close Corporations (if applicable) _____

1.4 Business physical address _____

Postal code _____

1.5 Business postal address _____

Postal code _____

1.6 Telephone no. () _____ Fax no. () _____

- 1.7 Cellular phone no. _____
- 1.8 Email address _____
- 1.9 Preferred method of communication (please tick): Email Fax Post SMS
- 1.10 Company contact person/s (full name and surname)
1. _____
2. _____
- 1.11 VAT Registration No. (if applicable) _____
- 1.12 Unemployment Insurance Fund No. (if applicable) _____
- 1.13 Compensation Commissioner Registration No. (if applicable)
- _____
- 1.14 Income Tax Reference No. _____
- NB: Insert Personal Income Tax Number if a one person business (sole trader) and Personal Income Tax Numbers of all partners in the partnership.

Good day

Thank you for your response to register on the Msunduzi Municipality Database. The application form of said database is attached for your attention.

Please complete the application form and return by hand the original form, together with the signed Affidavit to the office of:

Msunduzi Municipality
Procurement Unit
5th Floor, AS Chetty Building
333 Church Street
Pietermaritzburg
3200

For the attention of Ms Thembile Zondi (Telephone 033-392 2486).

The following documents must accompany your application:

- Original copy of a Tax Clearance Certificate
- Copy of CK1 form for Close Corporation businesses
- Bank statement/An original cancelled cheque
- If it is a Pty Limited, CM documents must be attached.

Once this office has been received the above documentation, your application will be added to the database.

THE MSUNDUZI MUNICIPALITY

EXECUTIVE: SUPPLY CHAIN MANAGEMENT (ACTING)

MISS D NDLOVU

Tel No. 033-392 2472 Fax No. 033-392 2532

SUPPLIES AND SERVICES CONTRACT No. 30 OF 2011

COLLECTION, CONVEYANCE AND DELIVERY OF MONIES

Tenderer's name: _____

Postal address: _____

Telephone no.: _____

Fax no.: _____

Email address: _____

Contact person: _____

Sealed tenders endorsed on the envelope "SUPPLIES AND SERVICES CONTRACT No. 30 OF 2011" must be placed in the Tender Box located in the Foyer, Ground Floor, City Hall, 169 Langalibalele (Commercial) Street, Pietermaritzburg, 3201, not later than 12h00 on 1 July 2011 when they will be opened in public. Only tenders placed in the tender box will be accepted and considered.

BUSINESS OWNERSHIP

List all the persons who are OWNERS in the Business/Trust, and indicate their involvement in the management/operation of the Business/Trust. In cases of Handicapped Persons, proof of disability by a recognised related institution must be submitted for registration purposes. If insufficient space, copies of this page may be made and added to this Form.

Full Name	ID Number	SA Citizen Before 27/4/94	Capacity: Member/Partner/Proprietor/Share holder/Trustee/Beneficiary	% Ownership/Trust/Interest	Male/Female	Disabled Yes/No	HDI Yes/No	(*) Race W/B/I/C/Other	% of time devoted to the business

(*) NB: The request for the Race of a person herein is required for STATISTICAL PURPOSES ONLY and is not intended to prejudice any Business in any manner whatsoever.

LEGEND

(W) - White (B) - Black (I) - Indian (C) - Coloured

Name of tenderer	Total tendered price Ex. VAT	Is tenderer responsive? Yes/No	Does tenderer have capacity? Yes/No	Is price realistic?	Tendered price of lowest tenderer	Points for price tendered	Points for HDI	Points for locality	Total points scored
						90.00	5.00	5.00	

Module 1

Letter of appointment

LETTER OF APPOINTMENT

Date: _____

Dear Team

Contract Number: RSA 101-314-2012/1: THE DESIGN AND SCALE MODEL
CONSTRUCTION OF THE UMZINDUZI RIVER BRIDGE

It is my pleasure to advise you that the local municipality, in conjunction with the municipality, has invited you to prepare a detailed bridge proposal and scale model for the above-mentioned project.

The deadline for your bridge design is _____ at _____ hours, after which a penalty of _____ % per day will be incurred by your team. The contents of your submission include the following:

- drawings of your design
- a budget/cost estimate for your design that includes the following costs
 - excavation
 - concrete
 - reinforcement
 - formwork
 - labour
 - skilled professional costs
 - miscellaneous items as detailed
- a portfolio containing all the work, drawings calculations, assessments, rubrics, sketches carried out in the reporting process The report should include any additional information that will help us, the client, to understand the value of your choices
- a model of your design built to scale
- a presentation made to the class and the client showing off your final design, sketches, budgets and the role played by each member of the team.

The scoring of your final submission will be as follows:

- model
- presentation
- drawings, sketches
- design brief
- file.

We look forward to receiving your future submission, and to the successful completion of this important community project.

Yours faithfully

Module 1

The tender process

If a business decides that it wants to tender for a particular project, in other words the business wants to submit a proposal to carry out a particular project, then it must put together a business plan. Each business must be aware that there will be other businesses who will also be submitting a proposal to do the same job. There is always lots of competition between businesses for the projects that need to be done.

A business plan is very important as it outlines the goals that the business aims to achieve, and it helps to establish the business's credibility with suppliers, customers and investors.

Suppliers need to know that this business will be able to pay them for the goods or services that they will be supplying. If the business needs to apply for credit (money), the plan will help to reassure whoever supplies the credit that the risk is minimal. In other words, there is a good chance that they will be repaid the money that they lend the business.

Advantages of a business plan

- Business owners who plan are more likely to survive.
- It gives you an overall view of the business and how different parts of it need to be co-ordinated.
- It makes you evaluate what you intend to do and when you hope to do it.
- It gives you a document against which you can measure your progress.
- It can be used to show interested stockholders the idea behind the business.
- It can be used to help raise financing.

(Teacher Guide: Foundations of Business, Machado, pp 183–186)

In your group start writing down ideas for your business plan. These are some of the aspects you need to think about:

- your company name, address and telephone numbers
- the names, addresses and telephone numbers of the owners and managers
- the names of the people who prepared the plan.

The business plan

- It is a summary of the total plan. It should only be written after the other information has been collected. It highlights the major decisions.
- The business plan outlines the type of business, its objectives, its location and the market it plans to serve. It must state whether it is a new or established business and if established, give a history.
- The business plan explains what service is going to be provided and what gives it an advantage over other competitors.
- The business plan must identify who your customers will be, how you identified your customers and the benefits they will obtain. It should also state the number of competitors you will face.
- The business plan explains who the managers are, their qualifications and skills.

If a business wants to tender for the municipality, then the first step is to collect a form from the municipality, which they must then fill in, to be registered. The form must then be returned to the municipality

The business is now registered and is on the list of tenderers.

There are usually two kinds of tenders:

- a) tenders putting forward ideas
- b) tenders specifying the cost of specific projects.

When South Africa became a democracy, it brought about changes in the business environment. Businesses are under pressure from politicians to empower members of previously disadvantaged groups and communities by appointing more managers and staff from previously disadvantaged groups in all parts of their businesses.

This has been done to compensate for the way in which most of the people were excluded from many jobs as a result of the apartheid policies of the previous Nationalist government. The situation has improved, but there is still an imbalance particularly in upper management levels.

Because of the above issues, points are given to certain groups in the tender process. They include the following:

- **Women**
They are given preference as they were marginalised in the past.
- **HDI (Historically disadvantaged individuals)**
This is a South African individual who could not vote due to the apartheid policy or is a female and/or who has a disability.
- **BEE**
BEE is Black Economic Empowerment, which redresses the inequalities of the apartheid era by giving previously disadvantaged groups (black Africans, coloureds, Indians and some Chinese) of South African citizens economic opportunities previously not available to them. Most companies now need to be BEE compliant.
- **SMME**
A SMME is a small, medium or micro enterprise. It is part of government policy to address former disadvantaged groups.

A form is supplied that needs to accompany the tender. As you can see, points are given for certain categories of owners, partners, members or shareholders.

Module 1









Bill of Quantities

BILL OF QUANTITIES

Item	Description	Unit	Quantity	Rate	Amount
100	Earthworks				
101	Approach embankment	m		12 500	
102	Excavation	m ²		200	
200	Falsework				
201	Scaffolding	m		500	
300	Concrete				
301	Abutments				
301a	Total height less than 4 m	No		50 000	
301b	Total height greater than 4 m	No		100 000	
302	Columns	m ²		1 600	
303	Pre-cast beams	m ²		1 500	
304	Bridge deck	m ²		2 000	
305	Pylons	m ²		4 000	
306	Arch-support	m ²		4 500	
400	Steel				
401	Truss bridge element	m		3 000	
500	Miscellaneous				
501	Vehicle barriers	m		2 500	
502	Pedestrian sidewalk	m		750	
600	Construction site camp				
601	Establishment	Sum		20%	
TOTAL					

Assessment: Module 1

1. Explain carefully what you understand by the term scale and why it is used in working drawings. [3]
2. Fill in the missing information about different types of lines used in graphic communication, in the following table. [7]

Description	Drawn line	General application
a)		Visible outlines Visible edges
b)		Imaginary lines of intersection Dimension lines Projection lines Leader lines Hatching Outlines of revolved sections in place Short centre lines Bending lines
Continuous thin, freehand		Limits of partial or interrupted views and sections, if the limit is not a chain thin.
Continuous thin (straight with zigzags)		Break line
Dashed thick		Hidden outlines
c)		Hidden edges
d)		e)
Chain thin, thick at ends and changes of direction		f)
Chain thick		g)

3. What are the three views of a first angle orthographic projection? Explain from where you view the object in each view. [6]

4. Draw this cup hook on a scale of 1:2 and then 2:1.

(4)

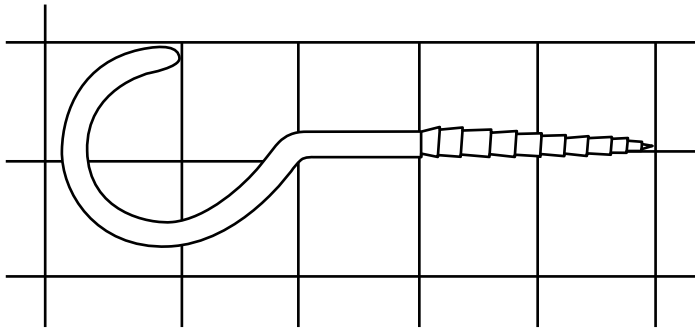

5. Copy the following drawings freehand.

(10)

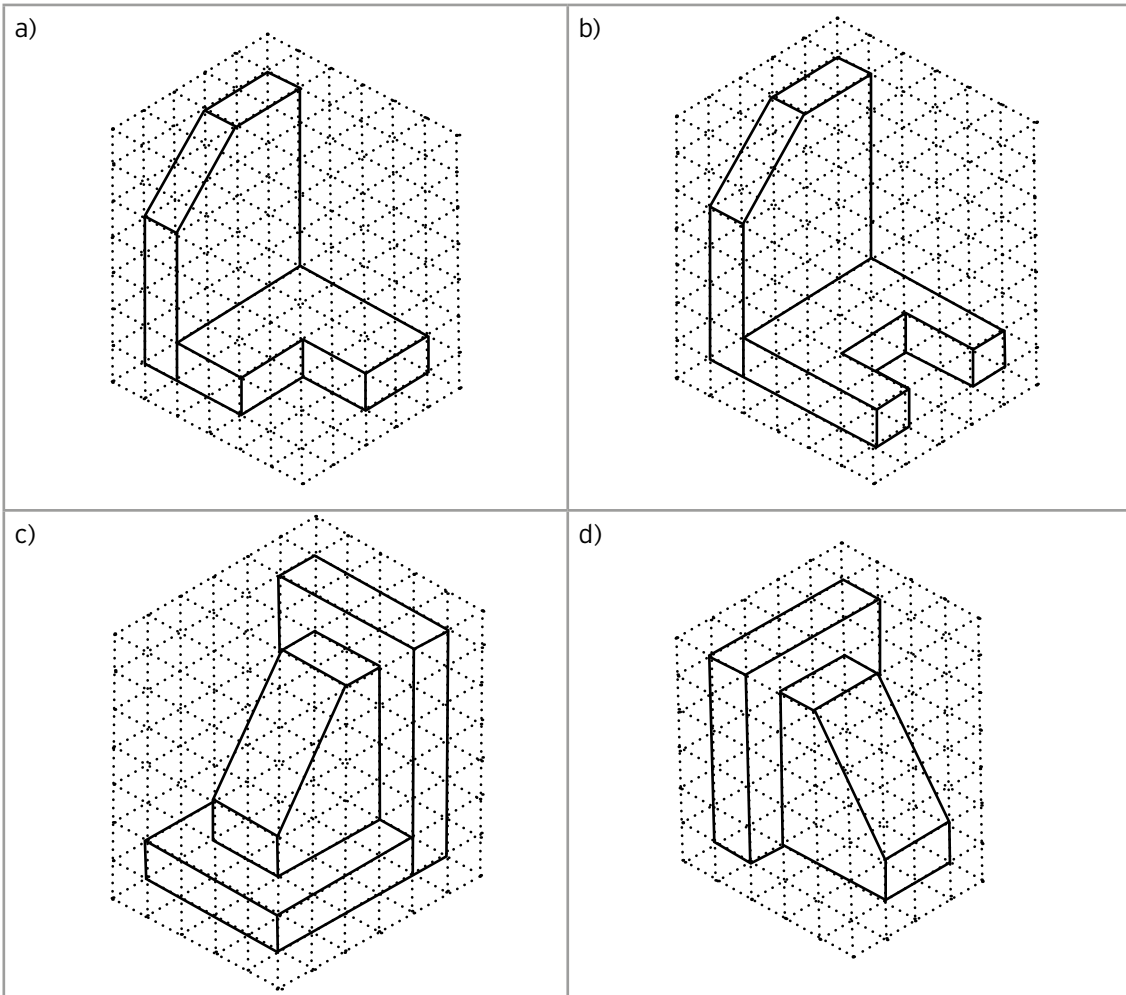

6. Study the working drawing and answer the questions that follow.

(9)

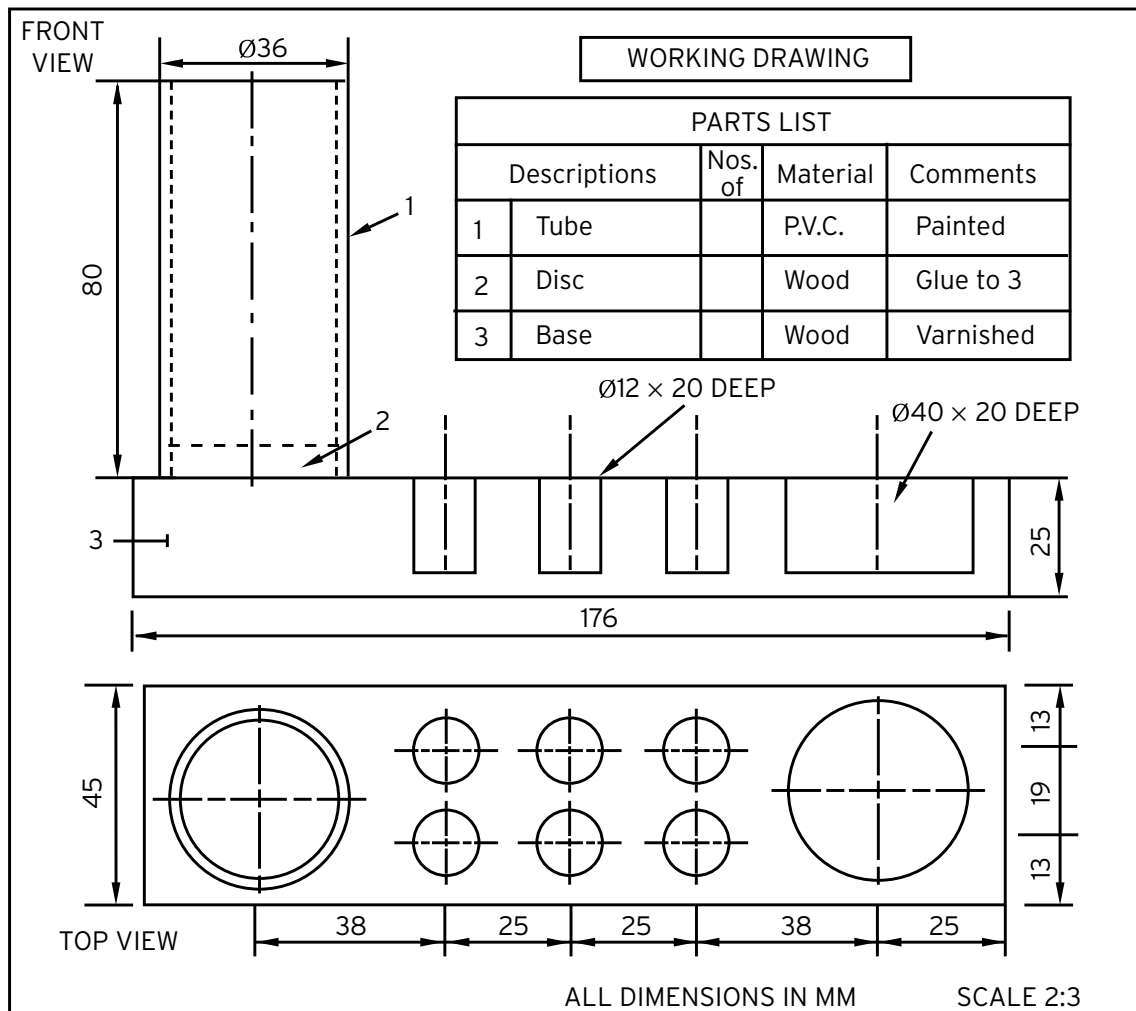

- a) Which parts are made of wood?
- b) How deep are the 12 mm holes?
- c) Which parts are made of PVC?
- d) How many views are drawn?
- e) How is part 2 joined to part 3?
- f) What finish will be used on the wood?
- g) How is the tube attached to the base?
- h) How thick is the base?
- i) Can the desk tidy be manufactured using only this working drawing?

7. Name the types of lines used in this drawing.

[7]

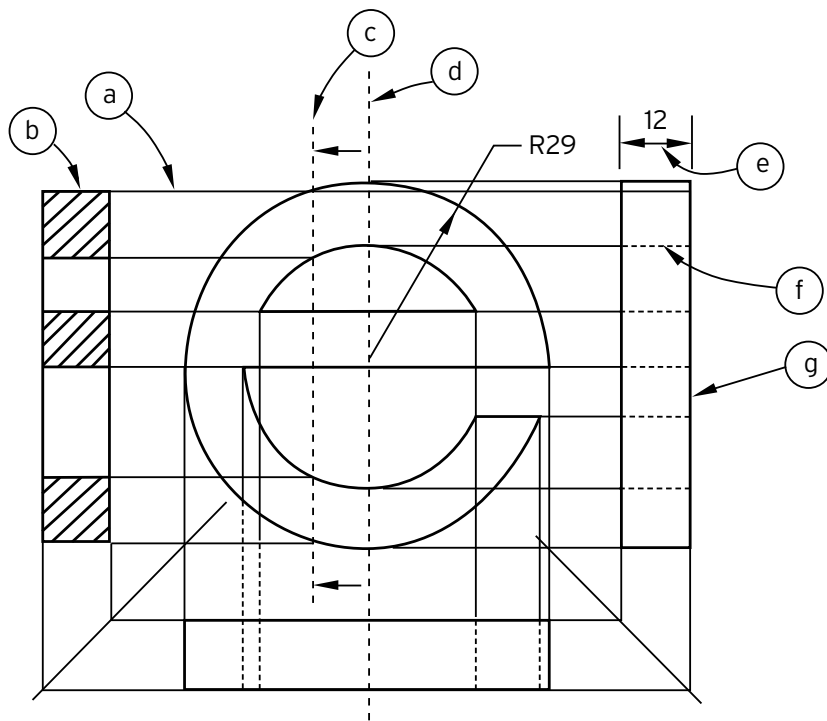

8. Explain the forces at work in the diagram below.

[6]

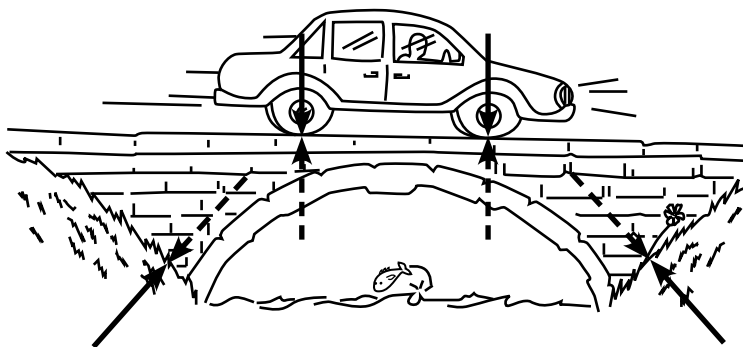

9. What is the difference between a static and a dynamic load? Give an example of each.

[4]

10. Look at the following pictures and decide what property of the material is being illustrated.

[4]

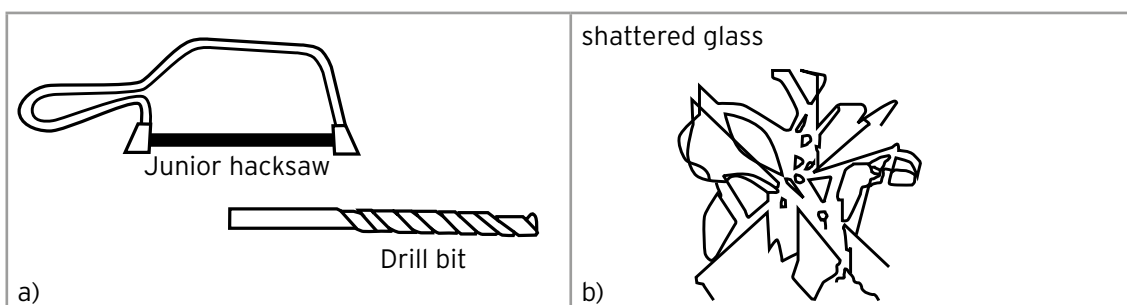

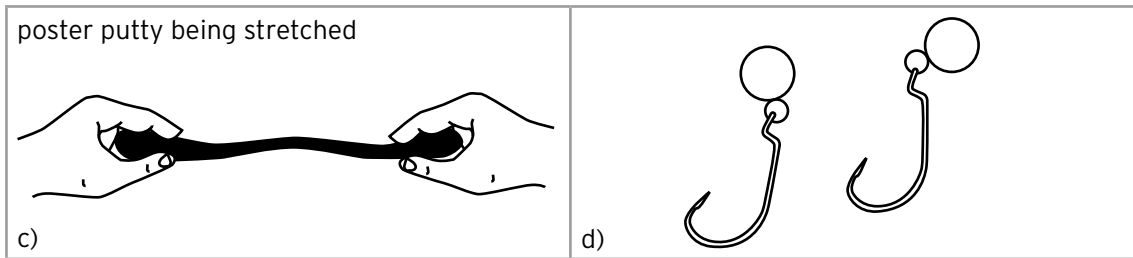

11. List and explain three more properties of materials not mentioned in the previous question. (6)
12. Explain why it is important to have knowledge of the property of a material before using it in a building project. (3)
13. List five questions you need to ask yourself before deciding on a specific material, such as wood, to use in a project. (5)
14. Look at the following pictures of different kinds of steel bridges. Put in the arrows to show the forces at work in each bridge when it is loaded. Name the different forces. (15)

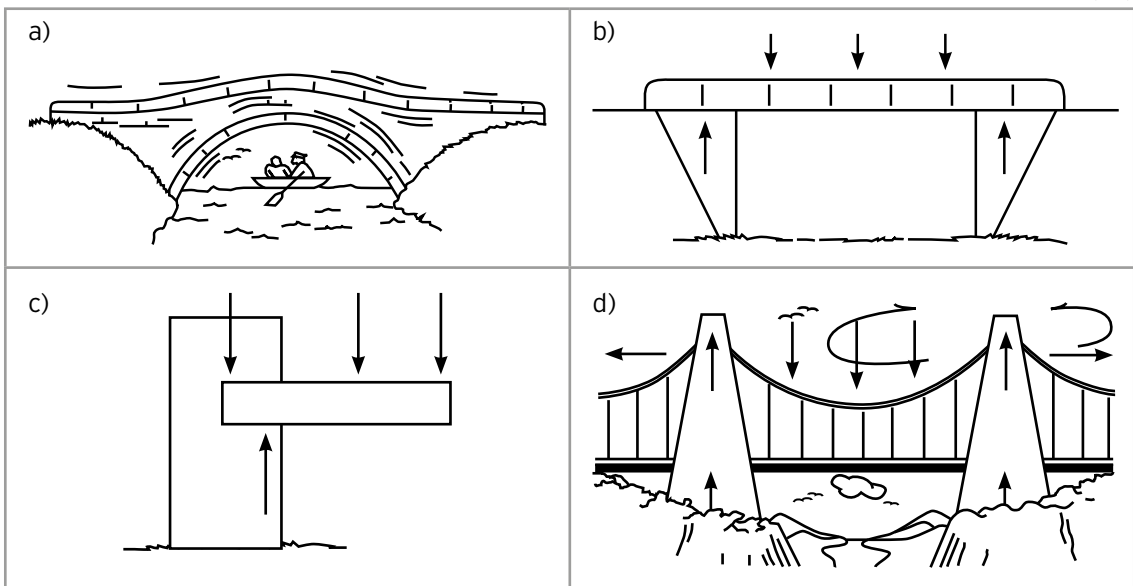

15. Why must an iron bridge be repainted often? (2)
16. What is a tender and why is it necessary? (2)
17. What are the advantages of having a business plan? (5)
18. Explain the following terms
 - a) BEE
 - b) HDI
 - c) SMME
 (3)
19. What two kinds of tenders are there? (2)
20. Match up the job with the job description.

	JOB	JOB DESCRIPTION
1	Site manager	A will, with the help of the team, devise a solution for the problem and oversee the working drawings for the design and the artistic drawing
2	Analyst	B oversees the actual construction of the structure, i.e. the model
3	Accountants	C analyses existing products/structures with regard to their suitability

	JOB		JOB DESCRIPTION
4	Design engineer	D	who will price the cost of the materials, transport and the labour required
5	Finance manager	E	is responsible for the collection of all the relevant materials to be used in the construction work
6	Construction manager	F	will oversee the budget and the calculations of the costing of the project

(6)

21. What are the three major costs when working out a budget? (3)

22. Look at the following drawing and find five things that show poor safety practices in the Technology classroom. (5)

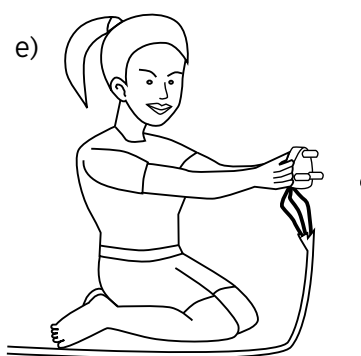
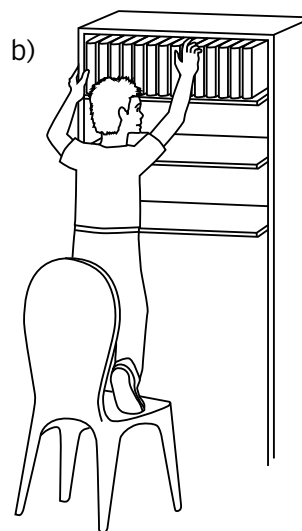
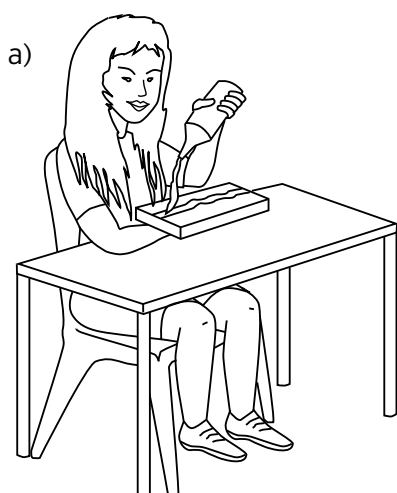





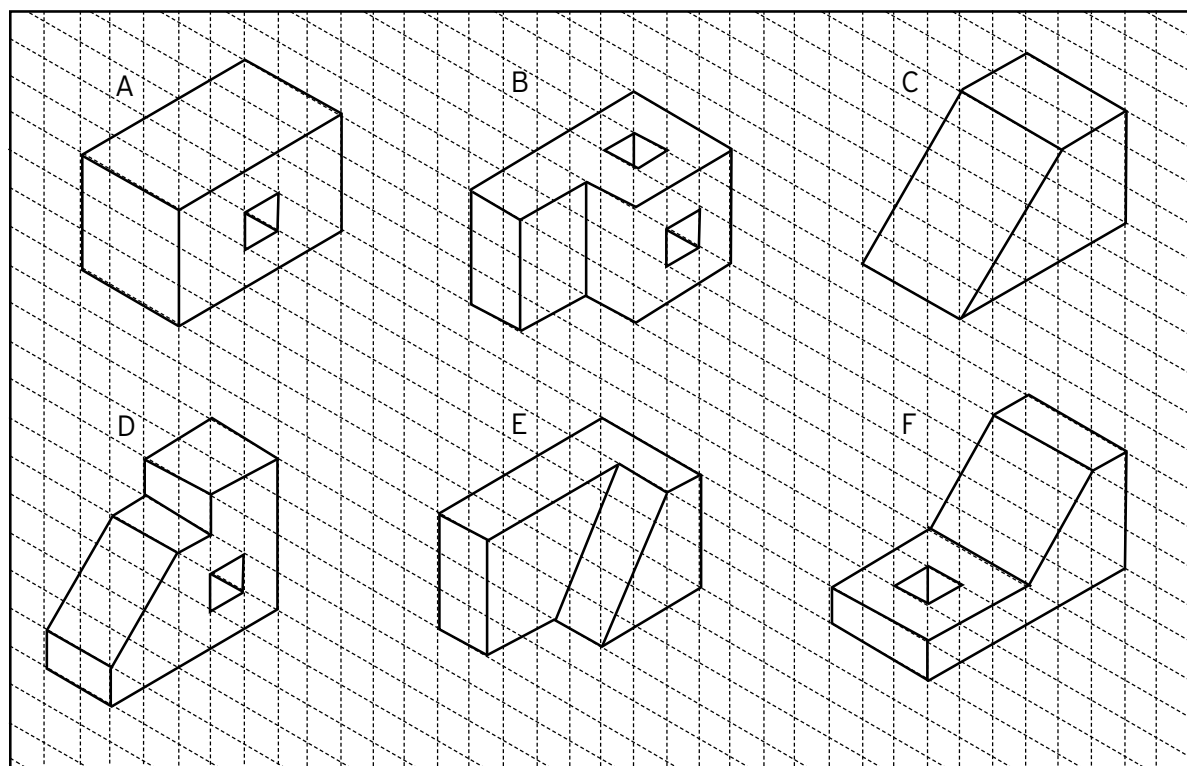
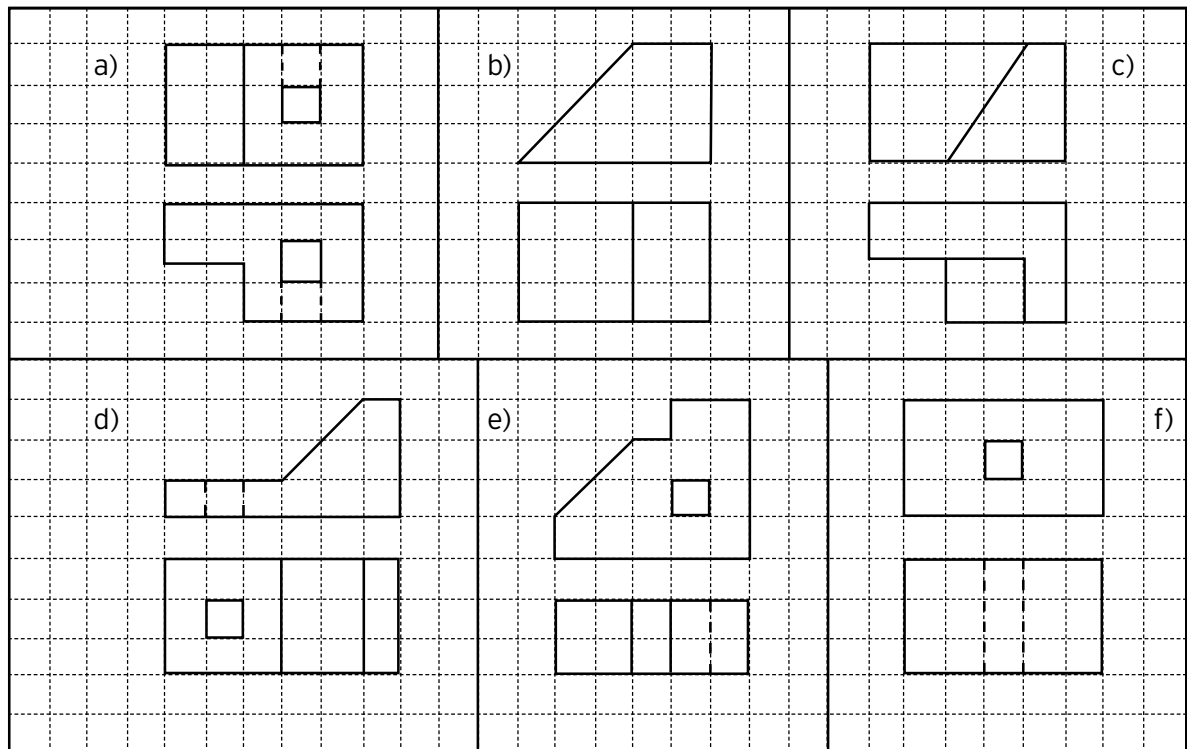



23. By making use of the length, width and height dimensions, indicate which of the following orthographic views correspond with the models below.

[6]



Assessment memorandum: Module 1

1. Scale is a ratio used to indicate the relationship between the drawing of the object and its real size. [3]
2. [7]

Description	Drawn line	General application
Continuous thick		Visible outlines Visible edges
Continuous thin (straight or curved)		Imaginary lines of intersection Dimension lines Projection lines Leader lines Hatching Outlines of revolved sections in place Short centre lines Bending lines
Continuous thin, freehand		Limits of partial or interrupted views and sections, if the limit is not a chain thin line
Continuous thin (straight with zigzags)		Break line
Dashed thick		Hidden outlines Hidden edges
Dashed thin		Hidden outlines Hidden edges
Chain thin		Centre lines Lines of symmetry Trajectories
Chain thin, thick at ends and changes of direction		Cutting planes
Chain thick		Indication of lines or surfaces to which a special requirement applies

3. Front view, drawn by looking directly at the front of the shape
Side view, drawn from looking at the side of the shape
Plan view, drawn by looking directly down on the shape from above [6]
4. Drawing of cup hook [4]
5. Assess freehand drawings. [10]
6.
 - a) Parts 2 and 3
 - b) 20 mm
 - c) Part 1
 - d) 2
 - e) With glue that is able to affix PVC to wood

- f) varnish
 g) with glue that affixes wood to wood
 h) 25 mm
 i) Yes [9]
7. a) construction line
 b) sectioning line/cross hatching
 c) section line
 d) centre line
 e) dimension line
 f) hidden detail
 g) visible outline [6]

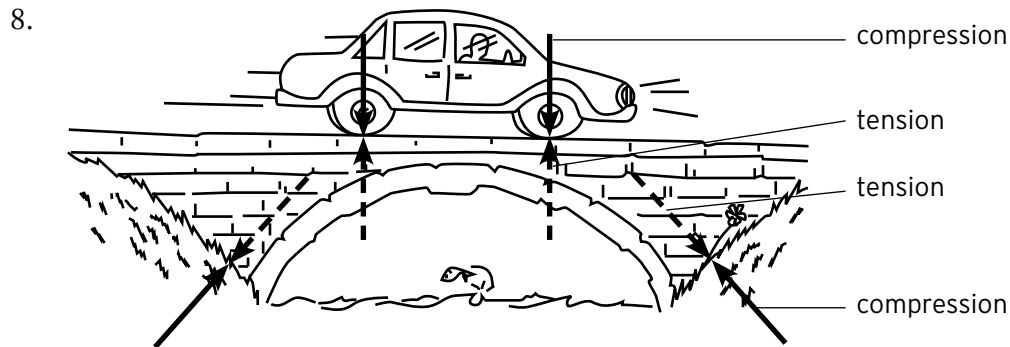

9. The difference between static and dynamic loads is that a static load does not change and is either the structure's own weight or is the load being carried by the structure, for example, a person standing holding a bag of groceries. Whilst a dynamic load is one that changes, for example, traffic crossing a bridge. [4]
10. Properties of material:
 a) hardness
 b) brittle
 c) ductile
 d) malleability [4]
11. Other properties: [6]
- tensile – how good the material is at withstanding a pulling force or tension force
 - compressive – how good a material is at withstanding a compressive or squeezing force
 - strength – refers to the force needed to break something and must not be confused with stiffness, which is a measure of how flexible something is. For example, steel is stiff and strong but although a biscuit is stiff it is not very strong
 - malleability – ability to be hammered or rolled without breaking
 - conductivity – ability to allow heat and/or electricity to pass through it
 - toughness – ability to withstand knocks without being damaged or fractured
 - durability – ability to withstand corrosion, wear and tear, weather conditions, etc.
 - stability – ability to resist changes in shape and size
 - weight/mass and density – some materials are light while others are heavy. Density is how densely (closely) the atoms are packed together in a material, making it easy or difficult to break
 - corrosion resistance – ability of the material to resist the process of rusting.
12. You have to know whether the material can perform the task required and not distort or bend under forces, rust or break. [3]

13. Is the material readily available? How much will it cost? Is it affordable? Is the material biodegradable? Will the use of the material have a negative impact on the environment? Is the material poisonous? [5]

14. Arrows showing forces [15]

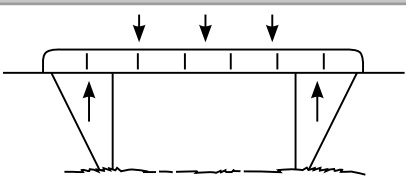
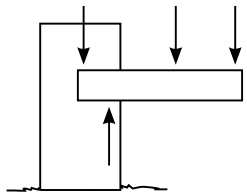
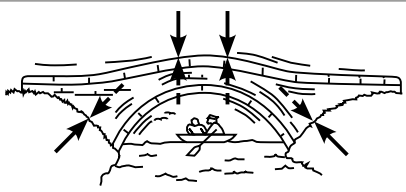
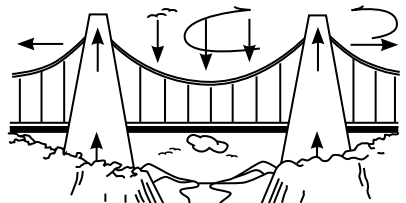
Bridge	Forces at work	
a) beam bridge	When loaded, the beam or girder bends downwards, producing tension in the lower part of the beam and compression in the upper part	
b) Cantilever bridge	When loaded, the beam bends, producing compression in the lower part of the beam and tension in the upper part	
c) Arch bridge	The bending effect on the beam and the tension effects are reduced by the compression forces provided by the abutments	
d) Suspension bridge	Nearly all the stresses are caused by tension. The pillars are under compression	

15. An iron bridge needs to be repainted as it begins to rust when exposed to the elements. [2]

16. It is a proposal to carry out a particular project. It is necessary to ensure that costs are kept down and that the best possible contractor is chosen, who is competent enough to carry out the work. [2]

17. Business owners who plan are more likely to survive. It gives you an overall view of the business and how different parts of it need to be co-ordinated It makes you evaluate what you intend to do and when you hope to do it. It gives you a document against which you can measure your progress. It can be used to show interested stockholders the idea behind the business. It can be used to help raise financing. [5]

18. a) BEE is Black Economic Empowerment, which redresses the inequalities of the apartheid era by giving previously disadvantaged South African citizens (black Africans, coloureds, Indians and some Chinese) economic opportunities previously not available to them. Most companies now need to be BEE compliant.
- b) A HDI is a historically disadvantaged individual who because of apartheid could not vote, or is a woman, or has a disability.
- c) A SMME is a small, medium or micro enterprise. [3]

19. Two kinds of tenders: tenders putting forward ideas and tenders specifying costs of a project. [2]

20.

1E	The site manager is responsible for the collection of all the relevant materials to be used in the construction work.
2C	The analyst analyses existing products/structures with regard to their suitability.
3D	The accountants will price the cost of the materials, transport and the labour required.
4A	The design engineer will, with the help of the team, devise a solution for the problem and oversee the working drawings for the design and the artistic drawing.
5F	The finance manager will oversee the budget and the calculations of the costing of the project.
6B	The construction manager oversees the actual construction of the structure, i.e. the model.

[6]

21. Cost of shuttering, cost of labour, overhead costs

[3]

22. Identify unsafe behaviour in picture such as:

- a) long hair loose
- b) standing on unstable chair
- d) the tie is not tucked away in the shirt
- e) the wires are exposed

[5]

23. a) B

[6]

- b) C
- c) E
- d) F
- e) D
- f) A

Assessment: Module 2

A little boy receives a Jack-in-the-box toy from his grandmother (see illustration).

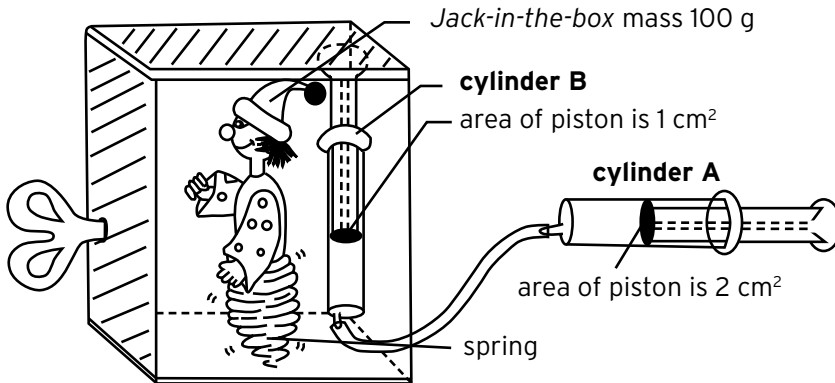



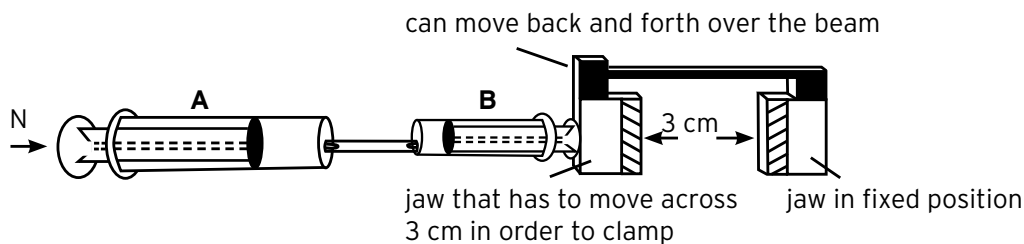

- 1
 - a) Calculate the amount of force, in newtons, that the little boy needs to make the Jack-in-the-box weighing 100 g shoot out, when the area at cylinder A is 2 cm^2 and the area at cylinder B is 1 cm^2 .
 - b) Calculate the mechanical advantage in question 1.
 - c) Calculate the distance that piston A must move to make the Jack-in-the-box shoot out 3 cm.
 - d) Would it be more advantageous to change around the two pistons, A and B?
2. You have to make a pair of hydraulic pliers, as indicated in the sketch. To enable you to do this, you are given two cylinders with pistons of 2 cm and 1 cm respectively. The maximum distance that the larger piston can move in the cylinder is 3 cm. A force of 1 N is applied to move the moving jaws of the pliers over a distance of 3 cm and to clamp the jaws of the pliers.

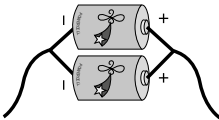

- a) Which of the two pistons are you going to place in position A for a minimum force input? Explain your answer.
- b) How far will the piston at cylinder A move to clamp the jaws?

Assessment: Components







Draw in the circuit symbol and give a short sentence of how the component is used.

Name	Picture	Symbol	Use
Series battery			
Parallel battery			
Push switch			
SPST switch			
Lamp/bulb			
Bell and buzzer			

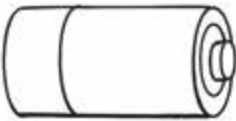
Assessment: Module 3

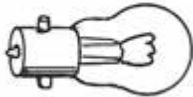
Name: _____ Date: _____

1. Draw the symbols for the following components:

Component	Function	Draw the circuit symbol
	Supplies electrical energy	
	More than one cell, supplies electrical energy	
	Allows the current to flow through the circuit	
	Converts electrical energy to light energy	
	Output device that gives off light	
	Converts electrical energy into sound energy	
	Controls the flow of current in a circuit; the current flows only when the switch is pushed	
	Converts electrical energy into sound energy	

2. Draw the circuit diagrams of the following circuits:

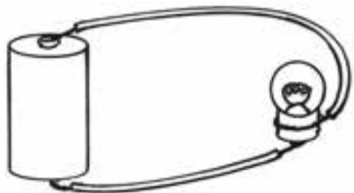
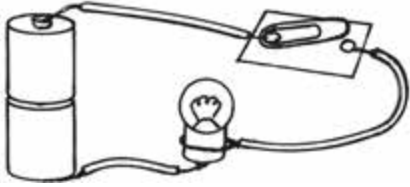
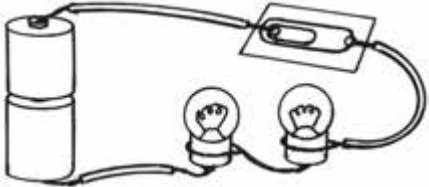
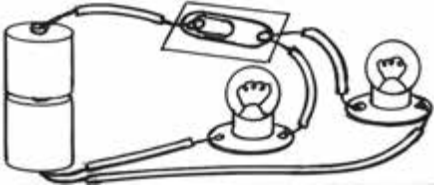
Circuit	Circuit diagram
	
	
	
	

3. Name these types of switches and draw the symbol:

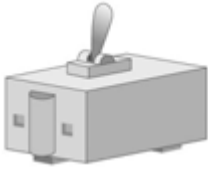
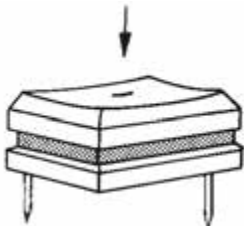

v

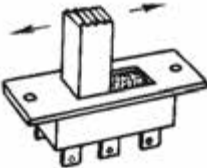
Switch	Name	Symbol
		
		
		



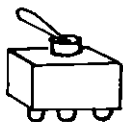

Switch	Name	Symbol
		

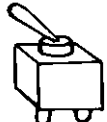
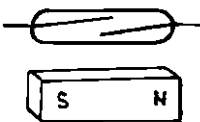
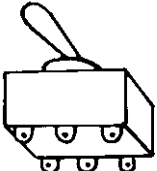
4. What happens to the voltage when lamps/bulbs are connected in series?
 - a. They become brighter
 - b. The voltage is shared
 - c. They don't work
5. What are switches used for in a circuit?
 - a. To move up and down
 - b. To turn the circuit off and on
 - c. To give the components power
 - d. To work as an insulator
6. How do you connect an LED (light emitting diode) to a circuit?
 - a. You connect the one leg only to the circuit
 - b. You connect the negative leg to the positive path
 - c. You connect both the legs of the LED to one insulated wire
 - d. You don't connect the legs of the LED to any insulated wire
7. What is the unit of measure for the flow of electricity?
 - a. It is measured in meters
 - b. It is measured in amps
 - c. It is measured in ohms
 - d. It is measured in kilograms
8. What is the unit of measure for resistance?
 - a. amps
 - b. ohms
 - c. meters
 - d. kilograms
9. What two things does a resistor do in a circuit?
 - a. It controls light and changes the direction of the power
 - b. It controls the flow of electricity and protects the components
 - c. It controls the buzzer and the bell
 - d. It controls the ohms and amps
10. What does a LDR depend on to work?
 - a. It depends on the amount of moisture
 - b. It depends on the amount of ohms
 - c. It depends on amount of light falling on it
 - d. It depends on the amount of touch
11. Where would you use a thermistor?
 - a. You would use it to make coffee
 - b. You would use it to make light
 - c. You would use it in a fire alarm
 - d. You would use it as a timer

12. In the language of logic, when a switch is closed it is said to be ...
 - a. at logic state 0.
 - b. at logic state 2.
 - c. at logic state 1.
 - d. at logic state 0 and 1.
13. For the component to work for an OR gate ...
 - a. one switch must be closed.
 - b. both switches must be closed.
 - c. none of the switches must be closed.
 - d. None of the above
14. For the component to work for an AND gate ...
 - a. one switch must be closed.
 - b. both switches must be closed.
 - c. none of the switches must be closed.
 - d. None of the above
15. SPDT switch stands for ...
 - a. super pole, double throw.
 - b. single pole, down throw.
 - c. single pole, double throw.
 - d. double pole, single throw.
16. DPST switch stands for ...
 - a. super pole, double throw.
 - b. double pole, down throw.
 - c. single pole, double throw.
 - d. double pole, single throw.
17. Name the switch and draw the symbols below:

Name the switch	Illustration of switch	Draw the symbol
		
		
		
		
		

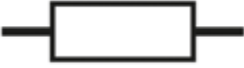
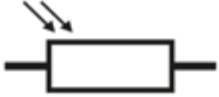
18. What do the following circuits represent in electricity?

Symbol	Drawing	Symbol name
		
		
		
		
		

19. Can you identify the symbols for the following logic states? Fill in the output in the truth table next to each symbol.

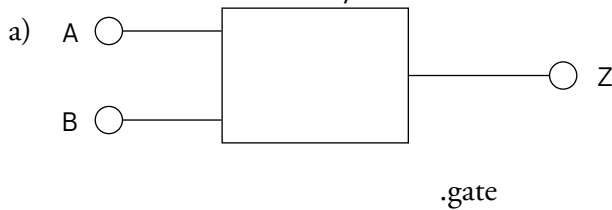

TRUTH TABLE

Input		Output
A	B	Z
0	0	
0	1	
1	0	
1	1	

0	0	
0	1	
1	0	

1	1	
---	---	--

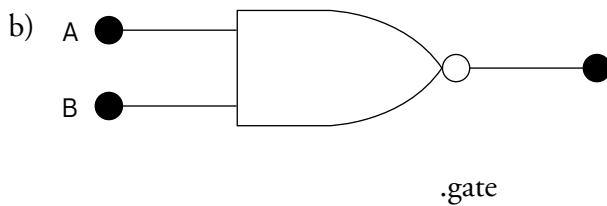

20. Complete the table below. Fill in the missing values of the resistors

How to determine the resistance of a resistor			
colour	1	2	Zeros
Black			
Brown			
Red			
Orange			
Yellow			
Green			
Blue			
Violet			
Grey			
White			















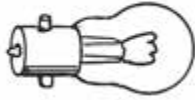

21. Complete the following sentences:



- a. The first two bands on the resistor represent the first _____ digits in the number.
- b. The third band represents the '_____'. (This is the number of zeros to be added at the end.)

22. Draw a circuit to show an OR gate.





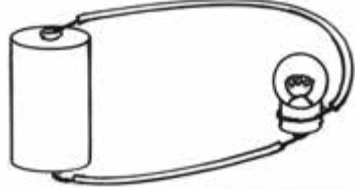

23. Draw a circuit to show an AND gate.

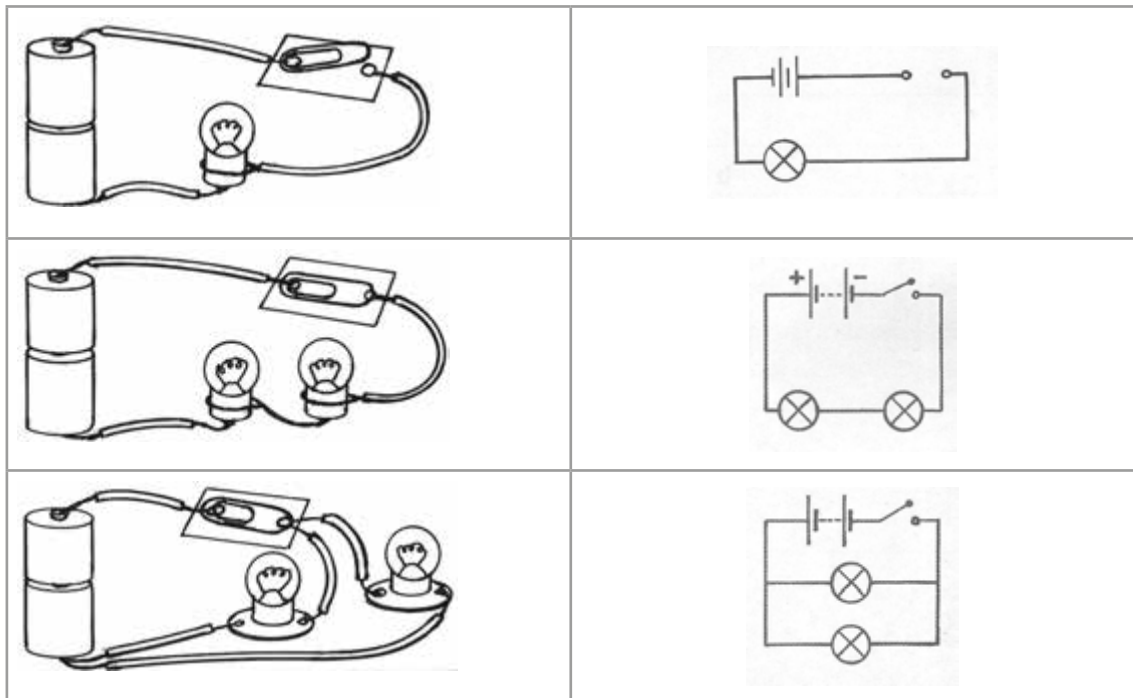
Module 3: Assessment memorandum

1.	Component	Function	Draw the circuit symbol
		Supplies electrical energy	
		More than one cell, supplies electrical energy	
		Allows the current to flow through the circuit	
		Converts electrical energy to light energy	
		Output device that gives off light	
		Converts electrical energy into sound energy	
		Controls the flow of current in a circuit; the current flows only when the switch is pushed	
		Converts electrical energy into sound energy	

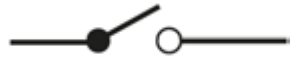
2.	Circuit	Circuit diagram
		

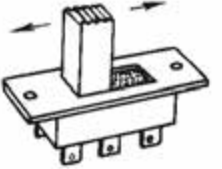









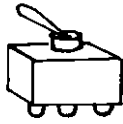

Switch	Name	Symbol
	Rocker switch	
	Toggle switch	
	Push switch	
	Slide switch	

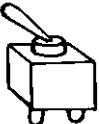

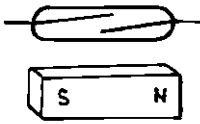

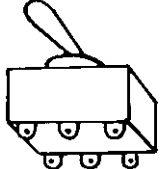

4. (b)
5. b
6. c
7. b
8. b
9. b
10. c

- 11. b
- 12. a
- 13. a
- 14. b
- 15. c
- 16. d

17.

Name the switch	Illustration of switch	Draw the symbol
Double-throw switch		
Push switch		
Single pole, single throw switch		
Slide switch		
Double pole, double throw		

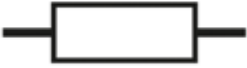
18.

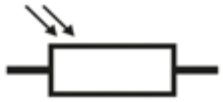
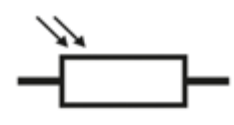
Symbol	Drawing	Symbol name
		Motor
		Touch or moisture detector
		resistor
		Light dependent resistor

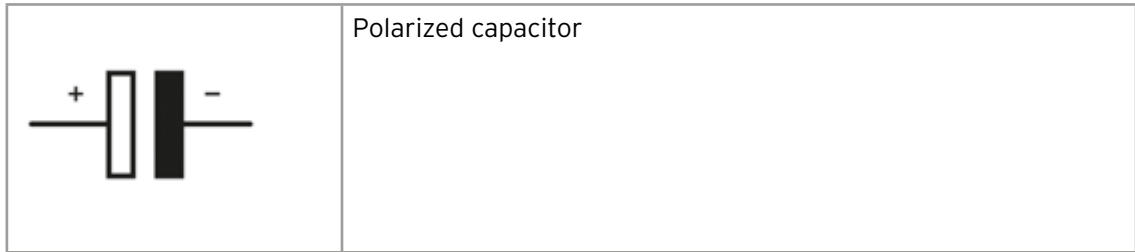

19. a) OR

b) AND

Possible answer: OR gate

	Input	output
A	B	Z
0	0	0
0	1	1
1	0	1
1	1	1

Possible answer: AND Gate

	Input	Output
A	B	Z
0	0	0
0	1	0
1	0	0
1	1	1

20. How to determine the resistance of a resistor







Colour	Band 1	Band 2	Zeros
Black	0	0	
Brown	1	1	0
Red	2	2	00
Orange	3	3	000
Yellow	4	4	0000
Green	5	5	00000
Blue	6	6	000000
Violet	7	7	0000000
Grey	8	8	00000000
White	9	9	000000000

21 a two

21 b decimal multiplier













Module 4

Types of plastic

Plastic product	Type of plastic used to manufacture product	SPI Identification code
		
		
		
		
		
		

Module 4

Memorandum - Types of plastic

Plastic product	Type of plastic used to manufacture product	SPI Identification code
	HDPE (high density polyethylene): milk bottles, detergent bottles, oil bottles, toys, plastic bags	
	Other: This code indicates that the item is made with a resin other than the six listed above, or a combination of different resins.	
	PET (polyethylene terephthalate): plastic cold drink bottles, water bottles, beer bottles, mouthwash bottles and many more	
	HDPE (high density polyethylene): milk bottles, detergent bottles, oil bottles, toys, plastic bags	
	PP (polypropylene): margarine and yogurt containers, caps for containers, wrapping to replace cellophane	
	PVC (polyvinyl chloride): food wrap, vegetable oil bottles, blister packaging, medical products	

Assessment: Module 4

Section A: Preserving metals

1. Explain each of the following terms. [6]
 - A Galvanising
 - B Electroplating
 - C Oxidation
2. List five industries where metals are used, and state a common metal product used in each of these industries. [5]
3. List three main steps involved in the process of hot tip galvanising. [3]
4. Match the galvanising process in Column A with *the purpose of the process* in Column B. Write only the letter of the alphabet in the Answer column. [6]

	Column A	Column B	Answer
1	Metal is placed in a hydrochloric or sulfuric solution	A Creates a protective coating to prevent steel from oxidising before galvanising begins	
2	Metal is lowered into as caustic bath solution	B Removes oxides	
3	Fluxing of metal	C Removes dirt, oil and grease	

5. List the factors that need to be taken into consideration when choosing a suitable paint to protect metal. [4]
6. Draw a simple flow diagram to show the galvanising process. [12]
7. Provide labels for the apparatus marked A to E in the electroplating kit shown below. [5]

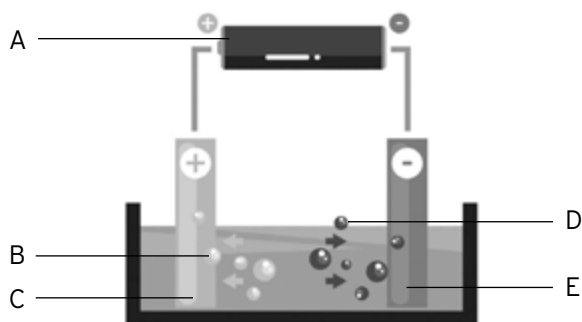





Section B: Food preservation

1. Draw an annotated diagram showing how the Nguni people used indigenous technology to preserve grain. [12]
2. Explain the role of carbon dioxide in indigenous food preservation. [3]
3. Draw a simple flow diagram explaining how vegetables can be pickled. [6]

Section C : Plastics

1. Explain in your own words each of the following commonly used terms associated with the manufacture and recycling of plastics. [6]
 - A The three Rs
 - B Closed loop recycling
 - C SDI Codes
2. Identify the type of plastic used to manufacture each of the following types of plastic products and draw the correct SDI symbol for the type of plastic used. [10]

Plastic product	Type of plastic used to manufacture product	SPI identification code
		
		
		
		
		

3. Tabulate the difference between:
 - A Thermoplastics and thermosetting plastics
 - B Blow moulding and compression moulding[8]
4. Draw a systems diagram showing the process of using waste plastic to manufacture pellets for reuse. [8]

An example of a generic analytical rubric to assess design capability in a mini-PAT

	Levels of competence				
	Exemplary	Competent	Developing but not yet mastering	Progressing	
	5	4	3	2	1
Generate and develop design ideas	Uses drawings reflectively to generate new ideas	Progression of ideas across or within drawings	Design ideas are generated but not developed	Simple sketch showing object to be made	Drawing a picture not designing a product
Explore the possibilities of the problem/need	Combining novel solutions to produce innovative design	Using drawings to develop novel design solution(s)	Recording possible creative solution(s) to the task	Stereotypical response, showing little creative thought	Design possibilities are not addressed in the drawing
Address the constraints of the problem/need	Task constraints treated as part of iterative process	Task constraints considered as the design proceeds	Records way to address task and/or client needs and wants	Drawings show some understanding of task constraints	Minimal understanding of task/user needs
Plan the look of the product	Ideas about finishing develop within overall design	Ideas about finishing are added to design whilst drawing	Overall decoration scheme considered	Little consideration of final appearance of product	Appearance of product is not considered
Communicate design ideas	Clear enough for somebody else to make the product	Conveys sense of the object to be made, e.g. working diagram	Conveys some sense of the object to be made, e.g. indicates materials	Simple unlabelled sketch(es); relying on shared meanings	Use of narrative or other drawing genre
Plan construction	Constructional issues considered en route to final design	Drawing demonstrates consideration of construction	Drawing indicates some consideration of construction	Minimal consideration of construction whilst drawing	Not planning to make the object drawn
Evaluate while drawing	Changes made a result of considering design drawings	Decisions made about products whilst drawing	Considered and rejected a range of ideas	Minimal evaluation at drawing phase	Yet to define the design task
Provide a basis for making	Using drawings as a resource during making	Clear development path through drawing into making	Object is one of the ideas drawn	Product relates to ideas recorded in the drawing	Making an object is seen as separate new activity
Comments to improve the learner's performance in design capability:					

Module 4 - Assessment memorandum

Section A : Preserving metals

1. Explain each of the following terms. [6]
 - A Galvanising – *Is the process of preserving a corrosive metal, such as steel, with a non-corrosive metal, such as zinc.*
 - B Electroplating – *Is the process commonly used to preserve metal by applying a fine metal coating to the metal object.*
 - C Oxidation – *Is the interaction of a substance with oxygen.*
2. List five industries where metals are used, and state a common metal product used in each of these industries. [5]
3. List three main steps involved in the process of galvanising. [3]
Surface preparation, galvanising, post-treatment
4. Match the galvanising process in Column A with *the purpose of the process* in Column B. Write only the letter of the alphabet in the Answer Column. [6]

	Column A		Column B	Answer
1	Metal is placed in a hydrochloric or sulfuric solution.	A	Creates a protective coating to prevent steel from oxidising before galvanising begins	C
2	Metal is lowered into a caustic bath solution	B	Removes oxides	B
3	Fluxing of metal	C	Removes dirt, oil and grease	A

5. List the factors that need to be taken into consideration when choosing a suitable paint to protect metal. [4]
The condition of the metal structure, the type of metal that needs to be preserved, the life expectancy of the metal and the environment where the structure is to be used.
6. Draw a simple flow diagram to show the galvanising process. [12]
Mark allocation:
1 mark for heading
1 mark for indicating start and finish points
1 mark for each step

Heading : Flow diagram showing the galvanising process

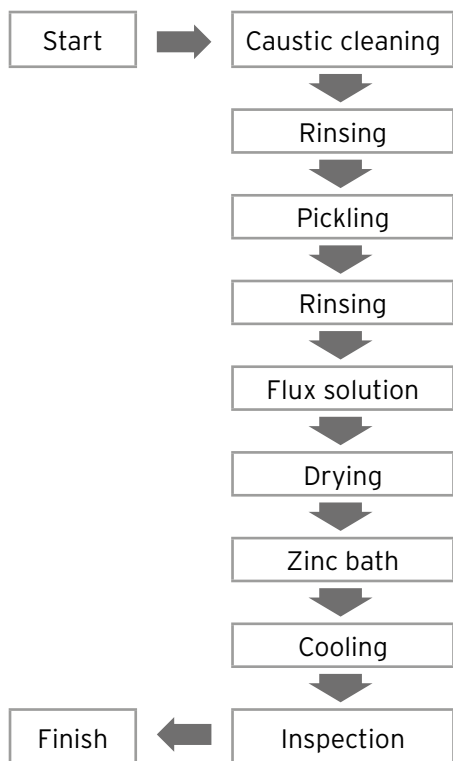

7. Provide labels for the apparatus marked A to E in the electroplating kit shown below. [5]

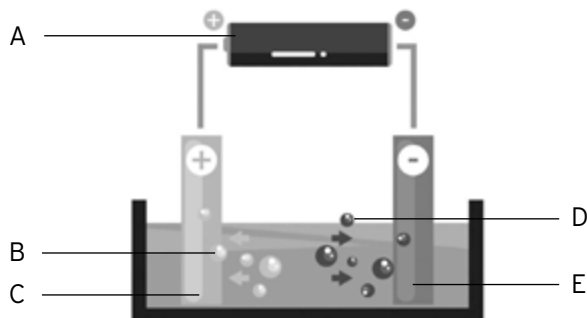

Answers

- A – Battery
- B – Sulfate ions
- C – Copper electrode
- D – Copper ions
- E – Nickel electrode

Section B : Food preservation

1. Draw an annotated diagram showing how the Nguni people used indigenous technology to preserve grain. [12]

Award the learner marks for the following details shown in the diagram.

- A – Pit is dug in the middle of a cattle kraal and lined with moist clay
- B – Fresh maize kernels are placed in the pit
- C – Entrance of the pit is covered with a large stone and covered with cow dung mixed with clay

- D – Grain kernels that come into contact with the damp clay ferment and release CO₂ into the pit, which prevents fungi and bacteria from developing
- E – When the grain is needed, the cover is removed and left open for a few hours to let all the CO₂ escape
- F – A small child is lowed into the pit to retrieve the grain.
- 6 marks for correct label on drawing
- 6 marks for explanation

2. Explain the role of carbon dioxide in indigenous food preservation. [3]





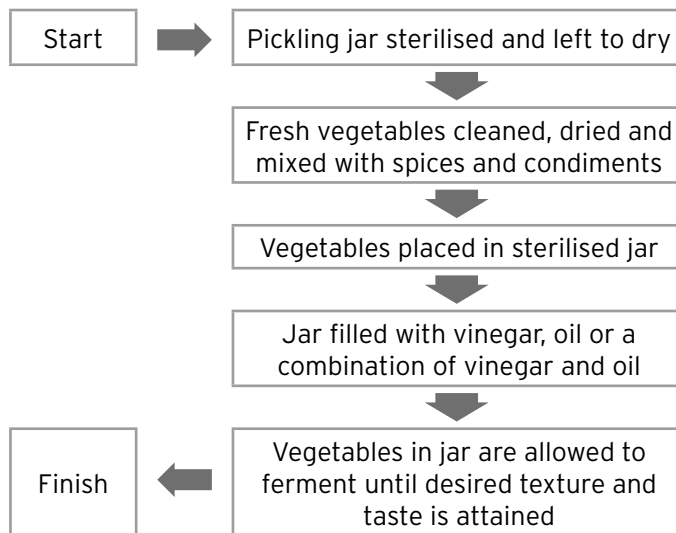





Grain kernels that come into contact with the damp clay begin to ferment and release carbon dioxide gas (CO₂) into the sealed grain pit, which prevents bacteria and fungi from developing. The sealed lid prevents insects and rodents from entering and protects the grain.

3. Draw a simple flow diagram explaining how vegetables can be pickled. [6]



Section C : Plastics

1. Explain in your own words each of the following commonly used terms associated with the manufacture and recycling of plastics. [6]
- A The three Rs – *Reuse, reduce and recycle plastic products whenever possible so that less plastic ends up in landfill sites.*
- B Closed loop recycling – *A production system in which the waste or byproduct of one process or product is used in making another product.*
- C SDI codes – *Codes developed by the Society of the Plastics Industry to help people classify plastics into the different types to make recycling easier.*
2. Identify the type of plastic used to manufacture each of the following types of plastic products and draw the correct SDI symbol for the type of plastic used. [10]

Plastic product	Type of plastic used to manufacture product	SPI identification code
	PET	
	LDPE	
	PP	
	HDPE	
	PVC	

3. Tabulate the difference between:

- A Thermoplastics and thermosetting plastics
- B Blow moulding and compression moulding

[8]

Thermoplastics	Thermosetting plastics
Thermoplastics are the plastics that do not undergo chemical change in their composition when heated and can be moulded again and again.	Thermosetting plastics can melt and take shape once. They cannot be returned to their liquid form, i.e. the process involved in thermosetting plastics cannot be reversed.
Blow moulding	Compression moulding
Blow moulding is when a melted polymer material is placed into a mould, air is injected into the cavity, which pushes the polymer into the desired shape.	Compression moulding is when a polymer is placed on the bottom half of a compression mould and the top half is lowered onto the bottom half pushing the polymer into the desired shape.

4. Draw a systems diagram showing the process of using waste plastic to manufacture pellets for reuse. [8]

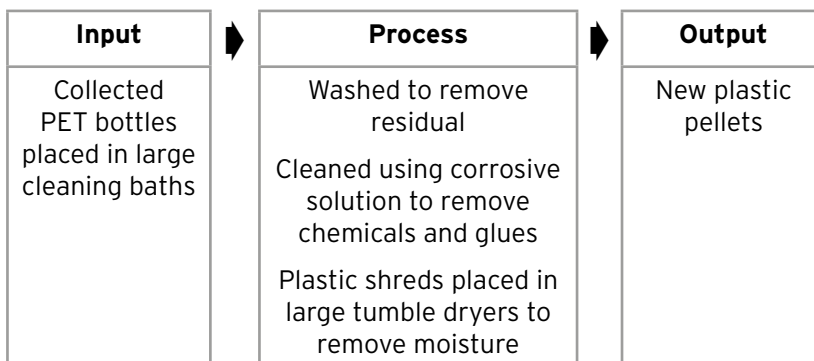

Mark allocation:

- 1 mark each for each aspect of the systems diagram [3]
1 mark each for each correct point [5]

Section F: Documents



You may add any other documents you receive in this section and list them for easy reference.

Technology

Study & Master Technology has been specially developed by experienced educators to meet all the requirements of the Curriculum and Assessment Policy Statement (CAPS). This new and easy-to-use course not only helps learners master essential content and skills in the subject, but gives them the best possible foundation on which to develop and build their Technology knowledge and understanding.

The comprehensive Learner's Book:

- provides an overview of content, concepts and skills covered in each term
- supplies activities that develop learners' skills and understanding of each of the topics specified by CAPS
- includes investigations, and practical tasks, as well as Formal Assessment Tasks in the form of Mini-PATs for each term
- features 'Did you know?' boxes with interesting additional information and 'Safety tip' and hint boxes that provide guidance on how to do technology tasks safely and easily
- includes a glossary of key words to help with the understanding of new terms and concepts.

The innovative Teacher's Guide includes:

- an expanded contents page and a work schedule for the year
- guidance on the teaching of each lesson and on each form of assessment
- step-by-step support in the teaching of activities and the carrying out of practical tasks
- photocopiable record sheets and templates, as well as additional worksheets to support your teaching.

Ria de Jager has a Masters Degree in Technology Education. She is Deputy Chief Education Specialist in Technology in KZN and Chairperson of the SA Technology Association. **Lin Bassett** has taught Technology at both government and private schools and presented various workshops at Technology conferences. **Barbara Munsami** is subject head (Technology) at Marist College and has facilitated workshops for both NGOs and DBE. **Lynn Pocock** has trained in Technology teaching methods, taught at a pilot school for Technology in 2005 and has been working in Special Needs and Remedial Schools for over a decade. **Neel Ramdutt** has an MEd in Educational Studies and Multimedia Design as well as a Certificate in Technology Education. He is now Deputy Chief Education Specialist (Technical Subjects / Technology) at the KZN Head Office.



PROUD PARTNERS



CAMBRIDGE
UNIVERSITY PRESS

www.cup.co.za