

## Small Steam Sterilizers

### FOR GENERAL PURPOSE APPLICATIONS

PRIMUS® small steam sterilizers come in **multiple chamber configurations** for your application. Designed for simplicity in operation and serviceability. These models are ideal for use in research laboratories, bio-containment environments, and animal care facilities.

CONTENTS	Page
Features	1
Standards	2-3
Control Systems	4-5
Configuration Options	6-7
Drawings & Dimensions	8-13
Configuration Worksheet	14-15



**Model AA**  
16" x 16" x 26"



**Model B**  
26" x 26" x 39"



**Model A**  
20" x 20" x 38"

### Features

Intelligent design focuses on ease of use, simplified diagnostics, and clear service access for maximum uptime.

- **Vessel Design** features a stainless steel, fully-jacketed 316L chamber. The vessel is insulated and mounted on a steel frame, which offers adjustable feet on self-centering floor pads.
- **Vertical Sliding Doors** are energy-efficient, safe, and can be operated with a finger-tip. Hands-free options are available.
- **Rectangular Chamber** eliminates wasted space and reduces high utility costs common to cylindrical or elliptical designs.
- **All Chambers** are polished to a mirror finish of <10 Ra. Surface finish can be just as critical in determining the corrosion resistance of austenitic stainless steel as the grade. Poor quality finishes can lead to disappointing performance of stainless steel. A highly polished surface will give the best performance in any specified environment.
- **Non-Proprietary Parts** are a hallmark of PRIMUS Steam Sterilizers allowing for immediate diagnostic and replacement of worn components.
- **Gravity, Vacuum, and Liquid Cycles** come standard on **all** models. Multiple test cycles are included for process challenge. Low temperature cycles and effluent decontamination are available for specific applications.
- **Configurable Controls** are adaptable to meet a variety of applications.
- **Water Conservation** is available with our PRI-Saver® system that offers up to **95% water savings**.
- **Predictive Maintenance** functionality included in our PLC based controls allows for increased uptime through the proactive monitoring of critical components.
- **Ease of Service** is built into the design and delivered by PRIMUS Authorized Service Agents.

## Specifications

### Standards

Each sterilizer meets applicable requirements of the following listings and standards, and carries the appropriate symbols.

- ASME Code, Section VIII, Division 1 for unfired pressure vessels. The pressure vessel is so stamped; ASME Form U-1 is furnished. Shell and door are constructed to withstand working pressure of 45 psig (310.2kPa)
- ASME Code, Section I, Part PMB for power boilers, if optional steam generator is supplied.
- UL/ICE/CSA61010-1 SAFETY REQUIREMENTS FOR ELECTRICAL EQUIPMENT FOR MEASUREMENT, CONTROL, AND LABORATORY USE -
- UL/ICE/CSA61010-2-040 SAFETY REQUIREMENTS FOR ELECTRICAL EQUIPMENT FOR MEASUREMENT, CONTROL AND LABORATORY USE PART 2-040: PARTICULAR REQUIREMENTS FOR STERILIZERS AND WASHER-DISINFECTORS USED TO TREAT MEDICAL MATERIALS
- UL 508A Standard for Industrial Control Panels

### Construction

#### Jacket Assembly

A Type 316L stainless steel chamber and a Type 304 stainless steel jacket are welded together to form the sterilizer vessel. Type 316L stainless- steel end frame(s) is welded to door end. On single door units, back of chamber is fitted with welded, 316L stainless steel formed head.

Sterilizer vessel is ASME rated at 45 psig (3.06 Bar) and insulated. The Vessel includes one 1.0" (25 mm) inch sanitary port for customer use.

Steam-supply opening inside the chamber is shielded by a Type 316L stainless steel baffle.

The unique design of the chamber jacket allows for even distribution of heat.

#### Chamber Finish

The brilliant PRI-Mirror chamber finish found in all PRIMUS models sets the highest standard for surface finish, achieving a 10 Ra (0.026 micron) measurement.

*"Surface finish can be just as critical in determining the corrosion resistance of austenitic stainless steel as the grade [58]. Poor quality finishes can lead to disappointing performance of stainless steel and a bright polished surface will usually give the best performance in any specified environment. 1 micron = 39.4 microinch Ra.*

*Coarse polished finishes with surface roughness values greater than 1 micron have been shown to contain deep grooves where chloride ions can accumulate and destroy the passive film, thereby initiating corrosion attack. In contrast, fine polished finishes with surface roughness values less than 0.5 micron will generally have fewer sites where chloride ions can accumulate"(Parrott and Pitts, 2011).<sup>1</sup>*

#### Chamber door

Door is constructed of a single formed piece of Type 316L stainless steel. Door is insulated to reduce the surface temperature of the stainless steel door cover.

During cycle operation, door is sealed by a steam-activated door seal. Door seal is constructed of an easily replaceable silicone gasket located in a channel groove in the chamber end ring. To ensure safety, a cycle cannot be started until the door is fully

closed and sealed. When sterilizer cycle is complete, the seal retracts by vacuum. The door cannot be opened while a cycle is in progress and the door will not unseal while the chamber is under pressure or vacuum.

Door interlocks on double door sterilizers are programmed to prevent inadvertent opening of door(s). An access key is provided to override door interlocks.

#### Chamber Drain System

Drain system is designed to prevent pollutants from entering into the water-supply system and sterilizer.

#### Drain Water Quench

The piping system provides automatic condensing of chamber steam and discharge to the floor drain. Cooling water is added to ensure discharge temperature is below 60°C (140°F). A separate temperature switch is included to regulate the volume of water so as not to exceed the required amount necessary to achieve target temperature.

#### Vacuum System

Chamber pressure is reduced during the conditioning phase and drying phase through the means of either a standard water ejector or a liquid ring vacuum pump. Following the drying phase, the chamber is returned to atmospheric pressure by admitting air through a 0.3 micron bacteria-retentive filter.

#### Steam Source

Sterilizers are piped, valved, and trapped to receive building-supplied steam delivered at 50 to 80 psig (344.7 to 551.6 kPa) dynamic. If building steam source is not available, an electric carbon-steel steam generator or electric stainless steel steam generator may be provided to supply steam to the sterilizer. Steam piping is constructed of brass and copper or stainless steel and includes a steam strainer and brass pressure regulator.

#### Steam to Steam

For applications requiring clean or pure steam, a Steam to Steam Generator is available. The quality of the steam produced will match the quality of the feedwater.

##### Pure Steam

- SCS1 The stainless steel Steam to Steam Generator with sanitary fittings comes with double tube sheet construction. Generated from WFI quality water. The water source to the Steam to Steam Generator is provided by others.

##### Clean Steam

- SCS2 The stainless steel Steam to Steam Generator with threaded connections comes with single tube construction. Generated from distilled and/or reverse osmosis water, the Clean Steam sterilizers normally include stainless steel piping for all wetted surfaces in the process loop.

#### Piping

All piping connections terminate within the confines of the sterilizer and are accessible from the front and side of sterilizer.

Solenoid valves with DIN connectors are arranged for easy removability and can be serviced individually.

## Specifications, Cont.

### Safety Features

**Chamber condensate alarm** activates alarm state if excessive condensate is detected in the vessel chamber drain.

**Door interlocks** (double door units only) allow only one door to be opened at a time and, during processing, prevent the unload side door from being opened until a satisfactory cycle is complete. If a cycle is aborted, the unload side door cannot be opened.

**Pressure relief valve** limits the amount of pressure buildup so that the rated pressure in the vessel is not exceeded.

**Door and gasket safety switch** signals when door seal is energized and tight against the door. Software prevents cycle from starting until the limit switch signal is received. If control loses appropriate signal during cycle, an alarm state is activated.

**Emergency stop button** (located on front of the sterilizer) is included on all sterilizers with PLC control systems.

### Sustainability

#### PRI-Saver Vacuum Source and Water Conservation System

Provides an efficient vacuum source for PRIMUS steam sterilizers and decreases water consumption 97% as compared to water ejector vacuum systems.

Integral to the framework of the steam sterilizer, PRI-Saver takes up no additional space in the service area.

PRI-Saver's additional benefit in sustainability programs is that it allows for the steam sterilizer to operate on 120V electrical source, not the high voltage required for liquid ring vacuum pumps.

#### PRI-Egreen

PRI-Egreen is a standard feature that will shut off utilities to the jacket after the unit has sat idle for a specified period of time. Time is programmable and secured via the PLC in order to meet facility sustainability goals.

#### PRI-Egreen +

Shutdown may be programmed to activate at the end of any designated cycle or time of day. When activated, control system automatically shuts off all utility valves, conserving steam and water usage. Sterilizer utilities can be restarted either by programmed time or manual operation. A different shutdown and restart time can be programmed for each day.

#### Drain Cooling

Drain quench is a standard feature on all PRIMUS models. Discharge temperature below 140F.

### Cycle Descriptions

#### Standard and Optional Cycles:

**Prevacuum Cycle (standard)** for efficient sterilization of porous, heat-and moisture-stable materials at 100°C to 135°C (212°F to 275°F). Prevacuum cycle utilizes a mechanical air-evacuation system.

**Gravity Cycle (standard)** for sterilization of heat- and moisture-stable goods at 100°C to 138°C (212°F to 280°F). Gravity cycle utilizes gravity air-displacement principle. Pre-positive pulses for enhanced air removal are available in hard goods applications.

**Liquid Cycle (standard)** for sterilization of liquids and media in vented borosilicate glass or metal containers at 100°C to 138°C (212°F to 280°F). Liquid cycle uses enhanced solution cooling during exhaust (cooling) phase to control exhaust rate.

**Waste Cycle (standard)** for processing of laboratory waste. Parameters may need to be adjusted based on specific loads. Bags should not be completely sealed.

**Lab Low (Isothermal) Cycle (optional)** is for the processing of heat-sensitive and heat-coagulable solutions in vented borosilicate glass or metal containers at 100°C (212°F). Lab Low utilizes steam to enhance temperature control and prevents layering of steam and air within the chamber. Process maintains positive pressure in chamber to inhibit boiling. Temperature uniformity  $\pm 5^{\circ}\text{C}$ .

**Jacket Cooling (Optional)** improves exhaust time for liquid loads. Thermostatically controlled water is introduced gradually and in combination with air pressure to control load condition. This process dramatically reduces cooling time.

**Air Over Cooling (Optional)** provides air pressure to chamber during the exhaust phase to maintain pressure until load temperature is reduced to a set point.

**Effluent Decontamination Cycle (Optional)** for decontamination of biohazardous waste (BSL-3 and BSL-4 environments). Condensate is held in the chamber and decontaminated before discharge to floor drain. Steam is introduced through bottom of sterilizer chamber, and chamber is exhausted out top side of vessel. During purge and vacuum pulses, all purge and exhaust gases are vented through a 0.2 micron bacterial retentive filter. Optionally, filter housing can be steam jacketed to ensure filter integrity.

**Leak Test Cycle** (standard) for verification of door seal and piping system integrity.

**Bowie-Dick Test** is available for 121°C (250°F) and 132°C (270°F) prevacuum cycles.

## Specifications

### Touchpad Control Systems



The time-tested and reliable PRIMUS PSS5 Microcomputer Control is an industrial microprocessor providing accuracy and automation for all customer requirements. This simple, versatile control has become the first choice for both sterilizer users and service technicians.

The PRIMUS PSS5 control system provides for automatic operation through all phases of the sterilization cycle.

Cycle parameters can be selected and programmed by the operator. All cycle phases are monitored visually. Cycle completion indicators are provided both audibly and visually.

The control is an embedded Microcomputer system with non-volatile memory storage eliminating the need for battery back up. The computer consists of solid-state devices, isolated from heat and moisture in a NEMA-rated, shielded enclosure. The Microcomputer control is self-diagnostic and provides information to the operator on a 2-line, 16 character LCD located on the control touchpad. An audible tone accompanies all alarms indicating a problem with the cycle. When specified, cycle parameters may be locked out by the supervisor through the use of touchpad keystrokes.

The control touchpad provides information on cycle progress by LED indicators. Specific information on cycle parameters and progress, in addition to alarms, are shown on the LCD display. Cycle selection and programming are entered by control panel pushbuttons, which provide an audible signal when pressed. Controls include a cycle advance button to allow the operator to manually advance the cycle. The control panel indicates the use of cycle advance and which phases were advanced. It continually displays this information until the door is opened at the end of the cycle. Cycle progress including time, temperature, pressure, and alarms are reported on a 24-character thermal or impact printer.

The touchpad contains pushbuttons and the LCD display. Cycle progress is displayed by LEDs on the Operator's Panel. Inputs are made using the numbered cycle buttons (See Part III, User's Manual, Figure 2.1-1, Touchpad Display). Double door sterilizers have a touchpad near each door.



### PLC Control Systems - A Variety of Choices



Cutting edge and configurable, PRIMUS' PRI-Matic® series is a PLC based control platform designed to exceed the needs of any general purpose, research laboratory, containment or vivarium application. These platforms feature industry leading, non-proprietary components and pharmaceutical grade coding.

Standard displays ranging from 5.7" to 12.1" provide a full color, touch-sensitive screen. Standard are thirty programmable cycles, adjustable to meet specific processing requirements. Seven cycles come pre-programmed for ease of use. All control configurations are performed through the touch screen display.

Cycle values and operating features may be adjusted and verified prior to cycle operation. User Access, Profiles, Simplified Screens, Interactive P&ID (on certain models) and additional options can be configured or toggled on/off easily in the user-friendly menus.

Critical control system components are housed within a NEMA-rated sealed compartment which protect components from moisture and heat generated during sterilization process.

**Operator interface control panel**, consisting of touch screen and thermal printer, is located on load or non-sterile end of sterilizer. If the sterilizer is equipped with double doors, an additional touch screen is provided on the unload or sterile end.

- **Touch-Sensitive Screen** provides users with color, touch-sensitive displays featuring high definition TFT LCD displays. Screen sizes range from 5.7" to 12.1" diagonally with a resolution of 800x600 pixels, a selection with the largest HMI's (Human Machine Interface) in the market. These screens provide clear, sharp, and bright displays, even in environments with low light, by utilizing the 65,536 available colors. They deliver realistic images and the brightest displays (PRI-Matic 100).



- **Thermal Printer** located below the touch screen, provides an easy-to-read printed record of all pertinent cycle data on 2-1/4" wide paper. Data is automatically printed at the beginning and end of each cycle and at transition points during the cycle. A duplicate print can be obtained of the last cycle run. Additional print options include Ink-On-Paper Impact Printer, Ethernet printing and PRI-SND. PRI-SND system (Secured Network Device) stores cycle data in a .pdf format that can be accessed over a network.

Specifications

PLC Control Systems, cont.

Thermal printer take-up spool stores an entire roll of paper, providing cycle records which can be saved for future reference. Three paper tape rolls are furnished with each unit.

- **Unload side control panel** (equipped on double-door sterilizers only) includes a touch-sensitive screen identical to the operating end screen. Preprogrammed cycles can be started from the unload side control panel. Display concurrently shows the same information as the load side screen display.
- **Cycle configuration** is performed by accessing the system menu on the touch screen display after authentication. In addition to adjustment of cycle values, the following operating parameters can also be changed through the change values menu:
  - **Time Display and Printout Units** in standard AM/PM or 24-hour military (MIL) time.
  - **Selectable Cycle Name** permits user to name each cycle with any combination of letters, numbers, blank spaces, and underscores.
  - **Print Interval** permits time period adjustments between cycle-status printouts generated during the cycles phases.
  - **User Access settings** permit adjustment of access and security of up to 14 users on PRI-Matic 100 and up to 30 users on PRI-Matic 200.
  - **Security access code** is required to enter the administrator mode (changing values), and service mode. Servicing the sterilizer or accessing change values menu causes display to request access code entry. If access code is not properly entered, display returns to the standby screen, denying user access to the sterilizer or programming. Access to the sterilizer can be limited to 30 operators, each with a different access code.



- **Alarms** pulses red flags on and off during alarm conditions. Informational text is displayed to guide the user in resolving the alarm. A buzzer that sounds during an alarm and at a different rate for five seconds at cycle completion can be configured manually.
- **Temperature Display and Printout Units** in Celsius (°C) or Fahrenheit (°F). Temperature is set, displayed, and printed to the nearest 0.1°. Recalibration is not required when changing temperature units from °C to °F and vice versa.

- **SD Card** is provided for downloading cycle information to a customer-furnished Excel spreadsheet file. Up to six months of (one hour) cycles can be stored on the included flash card before card has to be downloaded to PC.
- **Battery Backed Memory** backs up all cycle memory. In the event of a power failure, the cycle is stopped and cycle data is recorded up to that phase. Once power is restored the system goes into an alarm state indicating there was a power failure. At that point the user must acknowledge the alarm and can then either resume or abort the cycle regardless of current phase.



Predictive Maintenance

Predictive maintenance features allow users and service technicians to monitor the life cycles of major autoclave parts. Monitoring and tracking life cycles of major autoclave components enables easier budgeting, minimizes downtime and increases productivity.

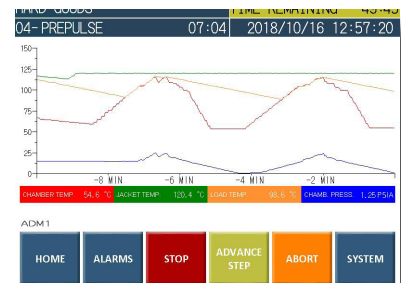

Real-Time Trend Graph Data

Automatically tracks vital temperature and pressure information. Shows process values for chamber, jacket, and load probe.

Step Detail Screen

Displays a description of the current cycle phase step, the conditions needed to advance the step, and any timeout conditions that apply. It is ideal for troubleshooting and acts as a training tool for new users.

User Authorization Levels

Four levels of authorization come standard with increasing varying access permissions. Standard levels include default, operator, technician and administrator. Additional levels can be custom configured. –

## Specifications, cont.

---

### Standard Features

---

**Lift Off Cabinet Panels** allow for convenient access to sterilizer piping and control system.

**Resistance Temperature Detectors (RTDs)** are standard for sterilizer temperature control. The chamber drain line RTD monitors and controls temperature variations within the sterilizer chamber. A jacket RTD provides temperature control within the jacket.

**Software Calibration** is provided for all temperature and pressure inputs. Calibration is available in the service mode and is accessible through the touch screen displays, and is performed using external or internal temperature and pressure sources. Control system provides a printed record of calibration data for verification to current readings.

**Cycle Data Records** are recorded on the printer tape and can be saved to a customer provided SD card. Data can also be retrieved for on-screen review or sent via e-mail if the system is enabled. Network connection required.

**Automatic Steam Shutoff to Jacket** is provided for Lab Low and liquid cycles. When activated for Lab Low cycles, the jacket control conducts a timed jacket drain, automatically allowing the operation of cycles at lower temperatures. When activated for liquid cycles, steam supply to the jacket is turned off during exhaust phase, allowing load to cool efficiently.

**Insulation**, one-inch thick, asbestos and chloride-free fiberglass completely encases the exterior of the sterilizer vessel and is sealed in an aluminum external cover.

**Air Backup** to door seals is optional on all double door sterilizers, with either bioseal or air differential seals.

### Options

---

**Stainless Steel Piping to Chamber** delivers steam generated from clean steam source to the chamber and its contents. All steam-to-chamber piping components are constructed of 300 series stainless steel.

**Stainless Steel Clean Steam Generator** automatically produces clean steam using customer-supplied steam and purified water. Generator is integrally connected to the clean steam-to-chamber piping system.

**RTD Load Probes and F<sub>0</sub> Sterilization** automatically sense the load temperature during cycle operation. A single thermal load probe is sealed through the sterilizer vessel and manually placed in the product container within the chamber prior to cycle operation.

In conjunction with the load probe option, individual cycles can be set to start sterilization phase according to chamber drain temperature or according to load temperature. Also, F<sub>0</sub> set points are available for each cycle, allowing for sterilization phase termination based on the calculated F<sub>0</sub> value.

**Bioseal** is a 1/4" stainless steel plate which is welded to the chamber and a 1/4" thick silicone gasket that extends between

the plate and a stainless steel wall frame which is welded to wall imbeds. The bioseal is provided on the unload side of the sterilizer and prevents passage of airborne microorganisms from the space between the vessel body and the structural wall opening. Steam is the primary source of pressure behind the door seal. All sterilizers with bioseals have air back-up to maintain seal pressure when out of cycle or if the steam source is not available.

**Air-Differential Seal** (double door units only), provided on the unload side of the sterilizer, minimizes airflow between the dirty and clean sides of the barrier.

**Back Cabinet Panel** is provided on single door, freestanding units where the unit is accessible on all sides.

**Power Door** provides automatic opening and closing by foot pedal or touch screen. (Not available for sterilizers with BioSeal option).

**Vacuum Pump Upgrade:** An Electric Vacuum Pump is offered in lieu of the standard water ejector vacuum system. This pump increases vacuum rate and decreases vacuum cycle times on larger chambers.

**0.2 Micron Bacterial Retentive Filter** provides sterile air during airbreak at end of cycle.

**Additional Chamber Penetration:** capped chamber penetration port is located at the side of the vessel preventing interference with other piping. The port provides for thermocouple probes or other test instrumentation.

**Form C Dry Contacts** provide four relays to communicate equipment status. Selectable statuses include: E-stop power, in cycle, cycle complete, cycle compromised, alarm state, and sterilizer power state.

### Piping Options:

- Brass and copper piping are standard on most sterilizers being the lowest cost option utilizing off the shelf components.
- Stainless steel threaded- generally used with clean steam and offers sufficient corrosion resistance.
- Stainless steel sanitary- for pure steam application highest level of cleanliness as they limit entrapment areas where bacteria could form or harbor. They are also corrosion resistant when used with purified water.

### Accessories

---

**Air Compressor, Portable**, 115 Vac. is intended for pneumatic valves on sterilizers when an air utility is not provided by the facility. It may also be used as a back-up pressure source for the door seal in bioseal applications.

This portable 2.35 gallon compressor tank that delivers 150 LPM @ 345 KPa (5.3CFM @ 100 PSI).

**Seismic tie-down kit** conforms to current California Code of Regulations.

### Specifications, cont.

#### American Made

All PRIMUS steam sterilizers are proudly designed and manufactured in the USA. Each unit is constructed of solid stainless steel and built in our quality controlled ASME facility using non-proprietary parts. Constructing our sterilizers in the USA ensures the durability and excellence of each unit we produce. Our employees are important to us and by keeping manufacturing local we are able to ensure high labor standards and employee satisfaction. Satisfied employees make for high quality products which we are able to pass on to our clients.

Our dedication to using non-proprietary parts stems from our commitment to meeting the needs of our customers. Non-proprietary parts ship much faster and we are usually able to deliver within two days.

#### Mounting Arrangement

Sterilizers are arranged for either freestanding or integral installation, as specified. Each sterilizer is equipped with a height-adjustable, steel floor stand.

On freestanding units, stainless steel cabinet side panels enclose the sterilizer body and piping.

#### Preventative Maintenance

Our highly trained service specialists provide periodic inspections and adjustments to ensure low-cost, peak performance. PRIMUS representatives can provide information regarding annual maintenance agreements.

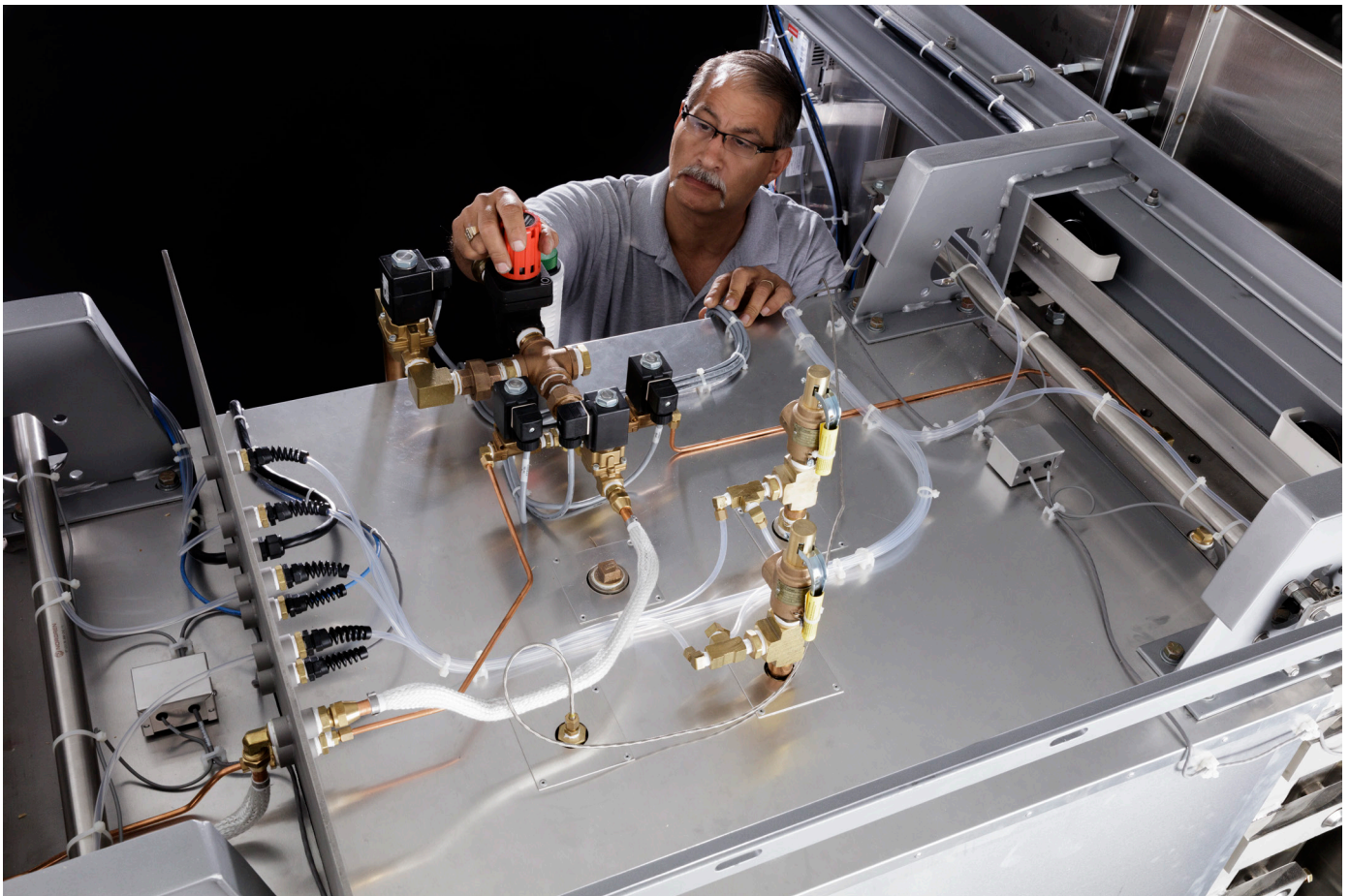

SINGLE DOOR

DOUBLE DOOR

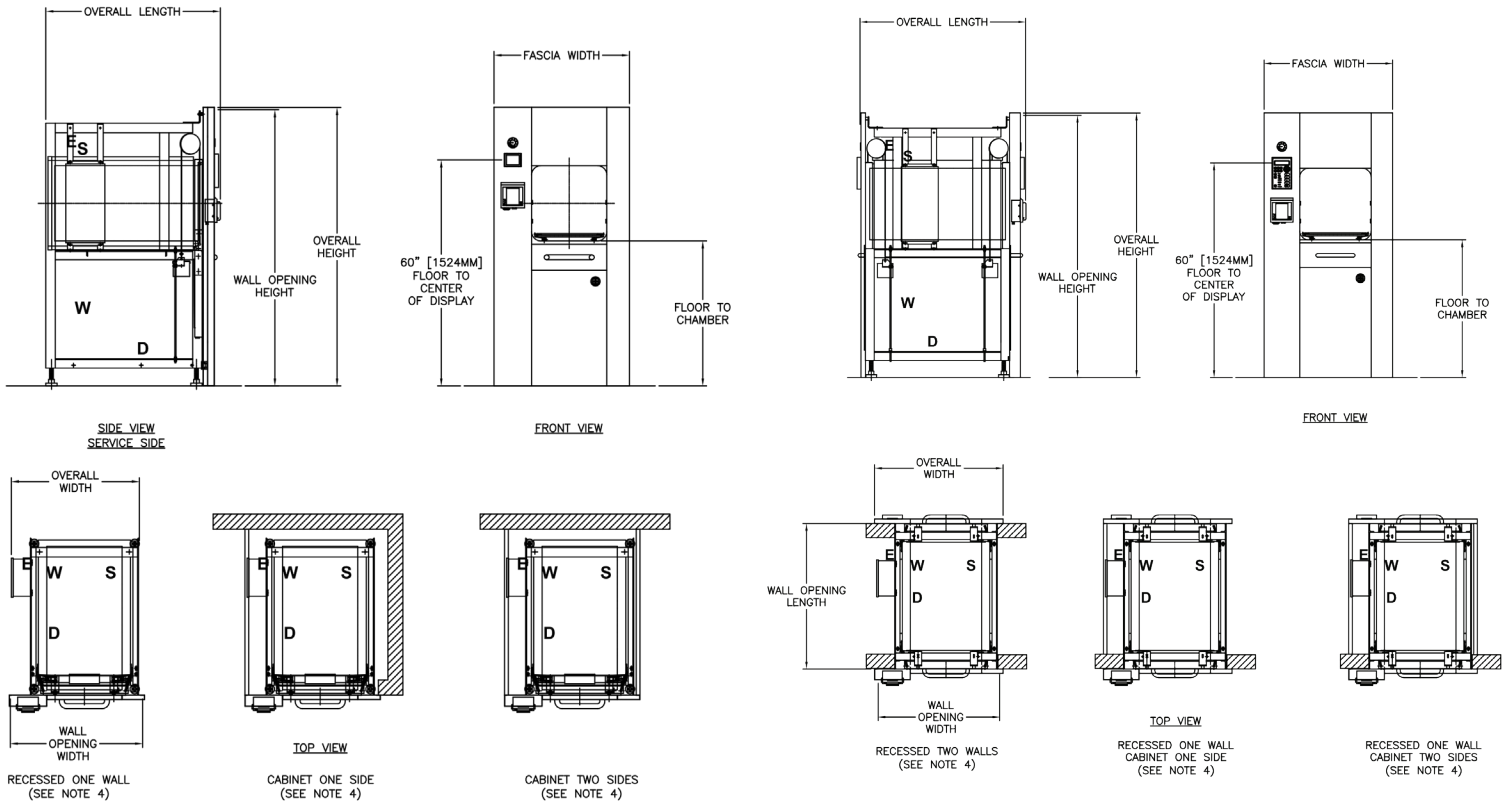

**Volume / Dimensions Chart Single Door**

\*Refer to General Arrangement (GA) drawings for details and final connection point to utility services (S-Steam, W-Water, D-Drain, E-Electrical, A-Air).

MODEL	AA	A	B	C	D
Chamber Size (W x H x L) Inches/Millimeters	16 x 16 x 26 406.4 x 406.4 x 660.4	20 x 20 x 38 508 x 508 x 965.2	26 x 26 x 39 660.4 x 660.4 x 990.6	26 x 26 x 49 660.4 x 660.4 x 1244.6	26 x 26 x 67 660.4 x 660.4 x 1701.8
Chamber Capacity	3.9 ft <sup>3</sup> / 109 L	8.8 ft <sup>3</sup> / 249 L	15.3 ft <sup>3</sup> / 432 L	19.2 ft <sup>3</sup> / 543 L	26.2 ft <sup>3</sup> / 742 L
Overall Width	25.38 / 644.6	29.25 / 743.0	35.50 / 901.7	35.50 / 901.7	35.50 / 901.7
Overall Height <sup>1</sup>	74.00 / 1879.6	74.00 / 1879.6	80.00 / 2032.0	80.00 / 2032.0	80.00 / 2032.0
Overall Length (SD) <sup>2,3</sup>	33.88 / 860.5	46.38 / 1178.0	47.56 / 1208.0	57.56 / 1462.1	75.50 / 1917.7
Wall Opening Width <sup>4</sup>	26.00 / 660.4	30.00 / 762.0	36.00 / 914.4	36.00 / 914.4	36.00 / 914.4
Wall Opening Height	73.00 / 1854.2	73.00 / 1854.2	79.00 / 2006.6	79.00 / 2006.6	79.00 / 2006.6
Wall Opening Length	32.00 / 812.8	44.00 / 1117.6	46.00 / 1168.4	56.00 / 1405.6	74.00 / 1857.4
Fascia Width <sup>1</sup>	30.00 / 762.0	34.00 / 863.6	40.00 / 1016.0	40.00 / 1016.0	40.00 / 1016.0
Floor to Chamber	38.50 / 977.9	38.50 / 977.9	32.00 / 812.8	32.00 / 812.8	32.00 / 812.8



**Volume / Dimensions Chart Double Door**

\*Refer to General Arrangement (GA) drawings for details and final connection point to utility services (S-Steam, W-Water, D-Drain, E-Electrical, A-Air).

MODEL	AA	A	B	C	D
Chamber Size (W x H x L) Inches/Millimeters	16 x 16 x 26 406.4 x 406.4 x 660.4	20 x 20 x 38 508 x 508 x 965.2	26 x 26 x 39 660.4 x 660.4 x 990.6	26 x 26 x 49 660.4 x 660.4 x 1244.6	26 x 26 x 67 660.4 x 660.4 x 1701.8
Chamber Capacity	3.9 ft <sup>3</sup> / 109 L	8.8 ft <sup>3</sup> / 249 L	15.3 ft <sup>3</sup> / 432 L	19.2 ft <sup>3</sup> / 543 L	26.2 ft <sup>3</sup> / 742 L
Overall Width	25.38 / 644.6	29.25 / 743.0	35.50 / 901.7	35.50 / 901.7	35.50 / 901.7
Overall Height <sup>1</sup>	74.00 / 1879.6	74.00 / 1879.6	80.00 / 2032.0	80.00 / 2032.0	80.00 / 2032.0
Overall Length (SD) <sup>2,3</sup>	35.94 / 912.9	47.25 / 1197.4	52.44 / 1331.9	62.44 / 1585.98	80.44 / 2043.18
Wall Opening Width <sup>4</sup>	26.00 / 660.4	30.00 / 762.0	36.00 / 914.4	36.00 / 914.4	36.00 / 914.4
Wall Opening Height	73.00 / 1854.2	73.00 / 1854.2	79.00 / 2006.6	79.00 / 2006.6	79.00 / 2006.6
Wall Opening Length	27.69 / 703.3	40.44 / 1027.2	41.44 / 1052.6	51.44 / 1306.6	69.44 / 1763.8
Fascia Width <sup>1</sup>	30.00 / 762.0	34.00 / 863.6	40.00 / 1016.0	40.00 / 1016.0	40.00 / 1016.0
Floor to Chamber	38.50 / 977.9	38.50 / 977.9	32.00 / 812.8	32.00 / 812.8	32.00 / 812.8

1. Fascia extends 1" beyond wall opening on each side overlapping the wall and sealing the opening.
2. Allow minimum of 2" clearance at rear of recessed unit only. Cabinet sides models have rear clearance built in.
3. Handle projects from the face of the fascia to the outer radius of the handle 2.375" for Models AA & A. Models B, C, & D the handle projects 4.25".
4. Contact PRIMUS for alternative wall opening.
5. Standard Left Side Service/equipment access shown. Optional right side access is available.



## Steam Source

### Electric Boilers

□ **EB** Carbon steel. Uses house supplied water. Includes feedwater boost pump.

□ **EBC** Stainless steel construction for clean steam generation. Includes stainless steel feedwater boost pump.

NOTE: Stainless Steel Boilers shall be operated using only deionized water, having a maximum conductance of 1 microsiemen per cm (1 $\mu$ S/cm) [minimum specific resistivity of 1 megohm per cm (1MW/cm)].

### PRI-Pure Reverse Osmosis System

□ **P30** Designed and recommended for all PRIMUS small sterilizers with integral carbon steel boilers. The PRI-Pure, when used together with softened water, will significantly increase boiler and sterilizer life by removing up to 99% of damaging contaminants.

## Boiler Utilities

MODEL		AA	A	B	C	D
Chamber Size (W x H x L) Inches/Millimeters		16 x 16 x 26 406.4 x 406.4 x 660.4	20 x 20 x 38 508 x 508 x 965.2	26 x 26 x 39 660.4 x 660.4 x 990.6	26 x 26 x 49 660.4 x 660.4 x 1244.6	26 x 26 x 67 660.4 x 660.4 x 1701.8
Boiler Size	kW/Hr	24	24	36	48	72
Boiler Steam Output	lbs/Hr	73	73	108	145	217
Integral	Model	EB1-AA	EB1-A	EB1-B	EB1-C	EB1-D
Stand Alone	Model	EB-AA	EB-A	EB-B	EB-C	EB-D
208 Vac, 3ph	Amperes	67	67	100	134	200
240 Vac, 3ph	Amperes	58	58	87	116	174
380 Vac, 3ph	Amperes	37	37	54	73	110
480 Vac, 3ph	Amperes	29	29	44	58	87
Vac 110, 60Hz <sup>1</sup>	Amperes	10	10	10	10	10

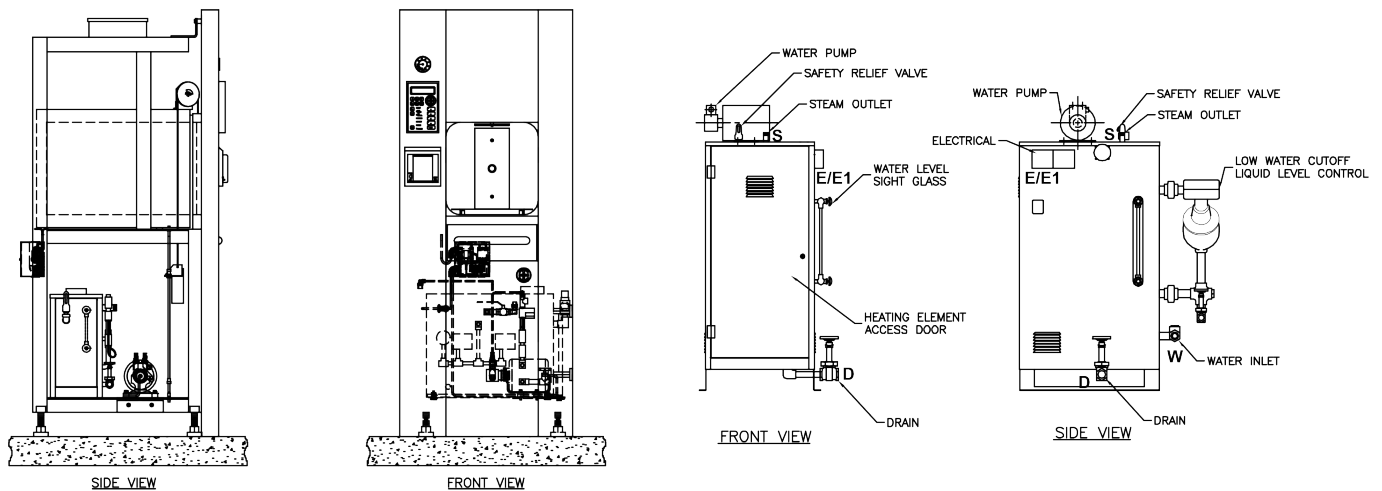

1. Electric boilers are available in Carbon Steel or Stainless Steel. Carbon Steel Boilers are integral on AA, A, and B sizes single door only. Additional options, if selected, may require stand-alone on these sizes. Specify whenever stand-alone is required on any model.
2. Contact PRIMUS for overall dimensions and utility connections.
3. All models are stand-alone.
4. GMP Validatable Option Only. Sanitary piping is required.
5. Low Water Cutoff is standard and the "automatic reset" feature is disabled with this option. The boiler will need to be manually reset.
6. Water Quality - For best results, feed water supply should be evaluated prior to initial startup to ensure it is of the quality necessary for the application, various external treatment processes (water softener, water conditioning, etc.) may be used. Contact PRIMUS for further recommendations.

**Electrical Connection and Utilities Consumption<sup>1</sup>**

Provide utility services within 6'-0" of final connection to sterilizer. Optimum sterilizer performance requires the specified utilities.

STEAM (S)			WATER (W)		AIR (A)	DRAIN (D)	ELECTRICAL (E)
Building Steam Supply <ul style="list-style-type: none"> <li>• <b>Pipe Size:</b> 3/4" NPT</li> <li>• <b>Quality:</b> Condensate free 97% to 100% saturated vapor (suitably trapped to ensure dry steam and filtered to remove particulates)</li> <li>• <b>Pressure:</b> 50 to 80 PSIG Dynamic</li> </ul> <b>Note:</b> <ol style="list-style-type: none"> <li>1. Steam-to-Steam Generator requires minimum pressure 65 PSIG house steam</li> </ol>			WATER (W) <b>Cold Water Supply</b> <ul style="list-style-type: none"> <li>• <b>Pipe Size:</b> 3/4" NPT</li> <li>• <b>Temperature:</b> &lt; 70° F</li> <li>• <b>Pressure:</b> 50-70 PSIG Dynamic</li> </ul>		Instrument Air <sup>2</sup> <ul style="list-style-type: none"> <li>• <b>Connection:</b> See Below</li> <li>• <b>Quality:</b> Dry and oil free</li> <li>• <b>Pressure:</b> 60-80 PSI Dynamic</li> </ul>	Building Drain System Minimum 2" <ul style="list-style-type: none"> <li>• <b>Location:</b> Locate floor sink directly under sterilizer</li> </ul> <b>Note:</b> <ol style="list-style-type: none"> <li>1. Exhaust discharge is cooled to &lt; 140°F</li> <li>2. 12" x 12" x 8" floor sink is recommended by PRIMUS</li> </ol>	ELECTRICAL (E) Building Power Supply - Dedicated Circuit <ul style="list-style-type: none"> <li>• Volts: 110</li> <li>• Phase: Single</li> <li>• Amps: 10</li> </ul> <b>Note:</b> Additional circuits required for ancillary and optional equipment i.e., vacuum pump, boost pump, boiler, etc.
MODEL	NPT	LBS/HR (KG/HR)	NPT	GPM (LPM)	NPT	NPT (Discharge Pipe Size)	
AA	3/4"	50 (22.68)	3/4"	8 (30)	1/4"	3/4"	
A	3/4"	65 (29.48)	3/4"	8 (30)	1/4"	3/4"	
B	3/4"	100 (45.36)	3/4"	8 (30)	1/4"	3/4"	
C	3/4"	134 (60.78)	3/4"	14 (53)	1/4"	1"	
D	3/4"	204 (92.53)	3/4"	14 (53)	1/4"	1"	

1. Based on sterilizer using a water ejector.
2. Not required for models with a vertically sliding door.

**HVAC DATA Heat** loss, at ambient of 70° F

	Model	KBTU'S/HR
SINGLE DOOR: Through one wall, at fascia	AA	1.5
	A	2.2
	B	4.1
	C	4.4
	D	4.1
SINGLE DOOR: Through one wall, service area	AA	1.9
	A	3.4
	B	5.7
	C	7.1
	D	9.7
SINGLE DOOR: Free standing, cabinet total	AA	3.4
	A	5.6
	B	9.8
	C	11.2
	D	13.8

	Model	KBTU'S/HR
DOUBLE DOOR: Through one wall, at fascia	AA	1.5
	A	2.2
	B	4.1
	C	4.4
	D	4.1
DOUBLE DOOR: Through one wall, service area	AA	3.3
	A	5.1
	B	7.8
	C	9.7
	D	11.5
DOUBLE DOOR: Through two walls, at each fascia	AA	1.5
	A	2.2
	B	4.1
	C	4.1
	D	4.1
DOUBLE DOOR: Through two walls, service area	AA	1.8
	A	2.9
	B	3.7
	C	5.6
	D	7.4

## Service and Equipment Access

When facing the load/dirty or BioSeal side of the unit, service access is from left side and top.

- **Wiring** is laid side-by-side in Panduit® raceway channels. All wiring is clearly labeled or readily visible.
- **Piping** components are threaded rigid brass and flared copper fittings, positioned with sufficient space for removal and replacement without disassembling the entire piping assembly.

Wiring and piping components are industrial grade, non-proprietary, and are available through authorized service agencies, local supply houses, or direct from PRIMUS.

## Warranty

Sterilizer pressure vessels manufactured by PRIMUS are warranted against defects in workmanship and materials under normal use and operation for fifteen years where the sterilizer is continually maintained under the PRIMUS or a PRIMUS Authorized Service Agent (ASA) service contract.

## Architectural Notes:

1. Allow sufficient space for traps, shut-offs, filters and other utility supply components.
2. Utility (service disconnects) shall be provided and installed "By Others".
3. Building or structure modifications to accommodate the sterilizer, as well as, sterilizer shoring, rigging, cribbing and/or crane requirements into the facility shall be provided "By Others".
4. Provide maximum mechanical and service access space, a minimum of 24", additional space required when boiler specified. See General Arrangement drawing for placement of ancillary equipment and service access.
5. Some options affect utility services and overall dimensions.
6. Water Quality - refer to page 10.
7. The Manufacturer's Equipment Warranty does not cover failure due to improper utility provisions.
8. Drawings not to scale.
9. Wall thickness must be provided on single and double door models recessed through 1 wall, with cabinet sides.
10. Floor under sterilizer must be water tight and sloped to the drain.

## Shipping Dimensions, Cubage, & Weights

Model Sterilizer Size Inches/Millimeters	AA 16 x 16 x 26 406.4 x 406.4 x 660.4	A 20 x 20 x 38 508 x 508 x 965.2	B 26 x 26 x 39 660.4 x 660.4 x 990.6	C 26 x 26 x 49 660.4 x 660.4 x 1244.6	D 26 x 26 x 67 660.4 x 660.4 x 1701.8
Overall Dimensions of Frame	25 x 73 x 32.5 635 x 1855 x 826	28.75 x 73 x 45 731 x 1855 x 1143	35.5 x 79 x 50 902 x 2007 x 1270	35.5 x 79 x 60 902 x 2007 x 1524	35.5 x 79 x 78 902 x 2007 x 1982
Weight, Single Door	<u>Contact PRIMUS for weights</u>				
Weight, Double Door					
Crated Weight (Additional)	200 lbs / 91 kg	200 lbs / 91 kg	200 lbs / 91 kg	200 lbs / 91 kg	200 lbs / 91 kg
Crated Dimensions	43 x 81 x 47 1093 x 2058 x 1194	47 x 81 x 59 1194 x 2058 x 1499	61 x 84 x 61 1550 x 2134 x 1550	61 x 84 x 71 1550 x 2134 x 1804	61 x 84 x 89 1550 x 2134 x 2261
Crated Cube	95 ft <sup>3</sup> / 2.7 m <sup>3</sup>	130 ft <sup>3</sup> / 3.7 m <sup>3</sup>	181 ft <sup>3</sup> / 5.1 m <sup>3</sup>	211 ft <sup>3</sup> / 6 m <sup>3</sup>	264 ft <sup>3</sup> / 7.5 m <sup>3</sup>
Loading Equipment	30.00 / 762.0	34.00 / 863.6	40.00 / 1016.0	40.00 / 1016.0	40.00 / 1016.0
Boiler	175 lbs / 79 kg	175 lbs / 79 kg	S.D. 250 lbs / 113.4 kg <sup>1</sup> D.D. 370 lbs / 167.8 kg <sup>2</sup>	375 lbs / 170 kg	450 lbs / 204 kg

1. Integral Boiler.
2. Stand Alone Boiler.

**Loading Equipment**

Chamber Size	Carriage Qty	Cart Qty	A	B	C1	C2	D	E	F
AA - 16x16x26	N/A	N/A							
A - 20x20x39	1-L6	1-L4	37.18"	38.50"	55.63"	48.06"	54.00"	19.00"	34.50"
B - 26x26x39	1-L6	1-L4	38.25"	32.00"	55.63"	41.06"	55.00"	21.00"	35.50"
C - 26x26x49	1-L6	1-L4	48.25"	32.00"	55.63"	41.06"	65.00"	21.00"	45.50"
D - 26x26x67	1-L6	1-L4	65.25"	32.00"	55.63"	41.06"	82.38"	21.00"	48.00"

Chamber Size	Carriage Qty	Cart Qty	G	H1	H2	J	K	L1	L2	L3
AA - 16x16x26	N/A	N/A								
A - 20x20x39	1-L6	1-L4	13.50"	15.00"	16.38"	3.00"	18.00"	33.00"	36.00"	N/A
B - 26x26x39	1-L6	1-L4	16.50"	19.50"	20.88"	4.00"	24.00"	34.00"	37.00"	N/A
C - 26x26x49	1-L6	1-L4	16.50"	19.50"	20.88"	4.00"	24.00"	44.00"	47.00"	N/A
D - 26x26x67	1-L6	1-L4	16.50"	19.50"	20.88"	4.00"	24.00"	62.50"	65.00"	30.50"

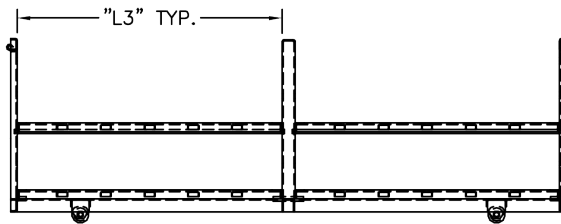

SIDE VIEW (60" CHAMBER OR LONGER)

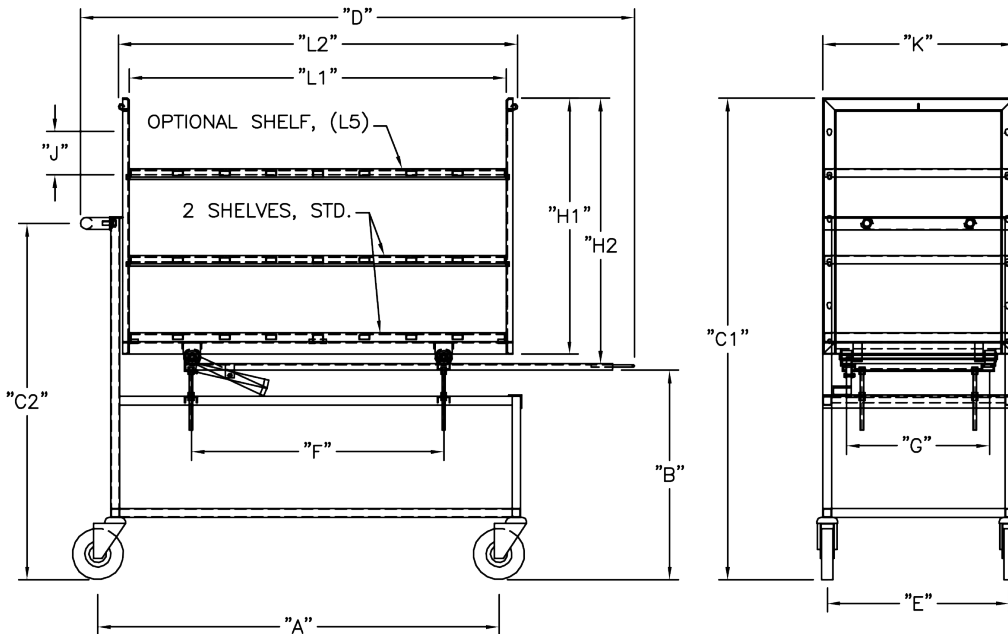

SIDE VIEW

END VIEW

## CONFIGURATION WORKSHEET

Use this worksheet to define your model number and compile your selections in the Configuration Options section of this document. Forward this completed worksheet to the PRIMUS Sales department (fax 402-344-4242) or your local PRIMUS representative. Remember, PRIMUS can address your customization needs. Please contact us for more information.

### Contact Information

Project name	
Project address	
Company name	
Contact name	
Contact email, phone and fax	
Quantity	
Specification section/drawing number	
Item number	
Room number	
PRIMUS quote number (completed by PRIMUS)	

### Chamber Size Options

MODEL	AA	A	B	C	D
Chamber Size (w x h x l) inches/millimeters	16 x 16 x 26 410 x 410 x 660	20 x 20 x 38 510 x 510 x 970	26 x 26 x 39 660 x 660 x 990	26 x 26 x 49 660 x 660 x 1240	26 x 26 x 67 660 x 660 x 1700
Chamber Volume	4 cu ft /109 Liters	9 cu ft /249 Liters	15 cu ft /432 Liters	19 cu ft /543 Liters	26 cu ft /742 Liters
Select size	<input type="checkbox"/>	<input type="checkbox"/>	<input type="checkbox"/>	<input type="checkbox"/>	<input type="checkbox"/>

### Base Configuration (Orientation)

- Door**
- DA Single Door
- DD Double Door
- Recessed**
- CA One Wall
- CB Two Walls

- Cabinet**
- CD Panels Both Sides
- CCL Left Side Panel
- CCR Right Side Panel
- Service and Equipment Access**
- C29 Left Side (Std)
- C30 Right Side

### Steam Source

- HS House Steam
- EB Electric Steam Generator - Carbon Steel\*
- EBC Electric Steam Generator - Stainless Steel\*
- SCS Steam to Steam Options - Consult with PRIMUS for details\*

### Controls and Related Options

- S5 PSS5 control system
- S11 PRI-Matic 100 Control System (PSS11)
- S9 PRI-Matic 200, MicroLogix™, Control System (PSS9)
- C11 Serial data output
- C32 Authorized user access
- C10 Remote mount control panel
- C25 Pressure values displayed in PSIA
- R7 Thermal printer
- R1 Impact printer

### General Options

- V3.1 Validation port (standard on models B, C, D)
- P4 Liquid-ring Electric Vacuum Pump
- P25 Drain line strainer/valve
- EAC Air compressor; unavailable with option P11
- NPN Site Specific Installation Requirements - Consult with PRIMUS for maximum utilization of available space\*

\*See detail section for specific option selection

## Bio-containment Options

- P8** Effluent decontamination configuration
- P8.1** Effluent decontamination as a cycle
- V6** BioSeal flange
- V10** BioSeal extension panel, stainless steel
- V12** BioSeal enhanced - gasketed
- P10** Compressed air to door gasket
- C23** Remote signaling of sterilizer status

## Sustainability Options

- P24** PRI-Saver water conservation system\*\*
- P30** PRI-Pure reverse osmosis water system\*\*

\*\*see page 3 for add'l details

## General Options

- DE** Manually-operated door (standard)
- DH** Power-operated door via control panel
- DG** Power-operated door via mushroom button
- DF** Foot-operated door
- CD** Cabinet, 2 sides
- CCL** Cabinet, 1 side left
- CCR** Cabinet, 1 side right
- CA** Recessed, 1 wall
- CB** Recessed, 2 wall
- NPN** Left side service access
- C30** Right side service access and control
- C31** Control panel opposite of service side
- CE** Top panel
- CF** Rear panel

## Vessel Options

- V1** Stainless steel frame
- V2** Jacket type, 316L SS
- V3** Jacket insulation cover, SS
- V6.1** Additional BioSeal flange; available on C and D models
- C3\*** Blind flange assembly, sanitary fittings
- C4** Jacket pressure display, analog, service area
- C4.1** Panel-mounted analog jacket pressure gauge
- C4.2** Panel-mounted digital jacket pressure gauge
- C4.3** Chamber and jacket pressure gauges (International 30-0-100)

## Loading Equipment Options

- L2** Extendable bottom shelf; *unavailable on model D*
- L3** Additional chamber shelf; *unavailable on model D*
- L4** Loading cart; *unavailable on model AA*
- L5** Additional cart shelf; *unavailable on model AA*
- L6** Transfer carriage; *unavailable on model AA*

## Steam Source Options - Detail

- EB1** CS Boiler, 208/3ph
- EB2** CS Boiler, 240/3ph
- EB3** CS Boiler, 480/3ph
- EBC1** SS Boiler, 208/3ph
- EBC2** SS Boiler, 240/3ph
- EBC3** SS Boiler, 480/3ph
- SCS1\*** Pure steam to steam double tube, sanitary
- SCS2** Clean steam to steam single tube, threaded
- EBO** Automatic boiler blow-down

## Piping

- P1** Brass & Copper piping and fittings (standard)
- P5** Safety Valve Over Rupture Disk
- P6** Quench Effluent on Demand to Drain (standard)
- P7** Condensate Sampling Valve
- P9** SS Chamber Piping
- P9.1** SS Jacket Piping
- P9.2** SS Lower Piping from first check valve to drain
- P10** Compressed Air to Gasket
- P11<sup>†</sup>** Air Over Pressure Chamber Cooling
- P13** Precise Temperature Control
- P14** Lab Low Process - Low Temperature Cycle
- P16** Jacket Cooling
- P20** Steam Quality Sampler
- P32** Chilled Water Return
- P33** Automatic Self Cleaning Drain line)
- P34** Pneumatic Valves
- P36** 0.2 Micron Filter

## Utility-related Options

- P3** Boost pump for low water pressure
- E1A** Step-down transformer from 220 VAC to 110 VAC
- E1B** Step-down transformer from 480 VAC to 110 VAC
- E1C** Step-down transformer from 480/240 to 240/120 VAC, 1 phase, 0.5 KVA
- E2** Uninterruptible power supply
- E3** GFI receptacle
- E4** Lighted Din Connections

## Additional Control Options

- C1\*** Conax adapter, 4 Gland
- C1.1** 1-1/2 Conax adapter, 8 Gland
- C1.2** 2 Conax adapter, 16 Gland
- C2\*** PRI-Matic F<sub>0</sub> control, F<sub>0</sub> accumulated
- C33** Display Centigrade
- C12** Chamber condensate alarm
- C13\*\*** Sterilize filter as a cycle
- C15\*\*** PRI-Matic in NEMA 4 rated enclosure (dust-proof)
- C16\*\*** PRI-Matic mounted in NEMA 12 enclosure (waterproof)
- C16.1\*\*** PRI-Matic mounted in NEMA 12 & 4X stainless enclosure (waterproof)
- R3\*** Strip chart recorder
- C17\*** "Sterilizer off" signal
- C18\*** Remote sterilizer "in cycle" signal
- C19** Chamber drain temperature, remote digital display
- C28\*\*** Ethernet Printing
- C33** Centigrade reading (displays and prints temperature in degrees Centigrade)
- C34** Automatic vacuum leak rate test
- C36** Ethernet connection for RS232
- C37** Form C dry contacts

## Documentation

- D1** GMP Validation Documentation
- D1.1** Chamber Mapping Only
- D1.2** Tagging Only
- D1.3** GMP Document Only
- D2** IQ/OQ Protocol, PSSS
- D5** IQ/OQ Protocol, PRI-Matic 200
- D6** IQ/OQ Protocol, PRI-Matic 100
- D8<sup>†</sup>** Software Source Code

<sup>†</sup> PRI-Matic control only

\*See detail section for specific option selection

All information contained in this document is for reference only.

The base language of this document is English. Any translations to other languages must be made from the base language.

**CUSTOMER IS RESPONSIBLE FOR COMPLIANCE WITH APPLICABLE LAWS,  
REGULATIONS, LOCAL AND NATIONAL REGULATIONS.**

---

## Contact Us



PRIMUS Sterilizer Company, LLC  
8719 South 135th Street, Suite 300  
Omaha, NE 68138  
(402) 344-4200  
Fax (402) 344-4242  
info@spire-is.com  
www.spire-is.com