

**Postharvest Horticulture Series No. 8E**  
November 2015

# **Small-Scale Postharvest Handling Practices: A Manual for Horticultural Crops (5<sup>th</sup> Edition)**

Lisa Kitinoja and Adel A. Kader

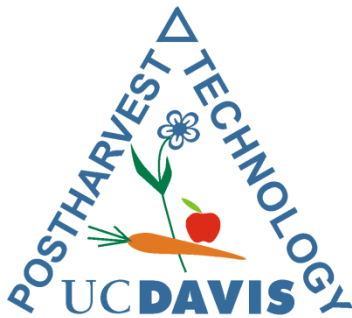

University of California, Davis  
Postharvest Technology Research and Information Center



## **Acknowledgments**

---

The development of the first edition of this manual was supported, in part, by USAID funds via USDA grant number 58319R-3-004, the National Agricultural Research Project, Ministry of Agriculture, Egypt. The first edition, published in June 1993, second edition (January 1994), third edition (March 1995) and fourth editions (Nov 2003) have been much in demand and encouraged our efforts to update the manual and produce a fifth edition.

Earlier editions of the manual have been translated into Spanish, French, Punjabi, Arabic, Afrikaans, Bengali, Khmer, Vietnamese, Bahasa Indonesian, Swahili, Amharic and Chinese with the assistance of our colleagues at the University of California at Davis and at agricultural universities and postharvest extension programs around the world. Translation into Hindi is currently underway. These manuals, as well as the 2015 5<sup>th</sup> edition in English, can be downloaded at no cost from the UC Postharvest Technology Center website <http://postharvest.ucdavis.edu>.

This fifth edition includes the practices for postharvest handling presented in earlier editions, while providing information on many additional practices for reducing losses, maintaining quality and ensuring food safety during small-scale handling and food processing of horticultural commodities.

Over the years we have had help from our colleagues at UC Davis, the University of Florida, USDA-ARS, the University of Wisconsin and from international colleagues as well. Thanks go to Jeff Brecht (UF), Joe Smilanick (USDA-ARS), Astrid Newenhouse (University of Wisconsin-Madison), Dr. SK Roy (Amity University, India), Eli Fallik (The Volcani Center, Israel), Fabio Mencarelli (Universita delgi Studi della Tuscia, Italy), Bruce Champ (Australian Centre for Agricultural Research, Canberra), Jose Emilio Suadi Hasbun (PROEXANT, Quito, Ecuador), Susan Woodhead (Natural Resources Institute, Kent, England), P.A. Hicks (FAO Regional Office for Asia and the Pacific), Sergio Chavez Franco (Centro de Fruticultura, Mexico), Seung Koo Lee (Seoul National University, Suwon, Korea), the staff at the ASEAN Food Handling Bureau (Kuala Lumpur, Malaysia) for providing updated references and access to unpublished materials, Angelos Deltsidis, Stephanie Tomuta and Marisa Jung of the Postharvest Technology Center at UC Davis for their technical and editorial review of the 5<sup>th</sup> edition.

During the revisions of this manual and before the completion of this 5<sup>th</sup> edition, Dr. Adel A. Kader passed away (December 2012). He is greatly missed by the international postharvest community, but his legacy lives on in the many young people who study postharvest technologies and apply them to improve the lives of small farmers all over the world.

Dr. Lisa Kitinoja  
The Postharvest Education Foundation  
[www.postharvest.org](http://www.postharvest.org)  
[kitinoja@postharvest.org](mailto:kitinoja@postharvest.org)

November 20, 2015

## **Disclaimer**

---

The Postharvest Technology Center (PTC) at the University of California, Davis does not guarantee the accuracy, adequacy, completeness or 'conformity and suitability-in-trade' of any information provided and is not responsible for any errors or omissions or for any results obtained from the use of such information. The PTC does not purport to and cannot provide legal advice or verification of conformance with industry-based standards or local, state, provincial, Tribal Nations, or federal level regulatory compliance.

In an effort to provide diverse options for the end-user of this manual, the authors have included information which is clearly not or may not be consistent with currently held regional, national, or global standards for safe food production, even for small-scale and limited resource operations. Adopting any recommendations, models, methods, protocols, or guidance presented or derived from any part of this manual does not ensure compliance with U.S. Food and Drug Administration's final Food Safety Modernization Act rules and related regulations or any other law or legal requirement for producers, shippers, handlers, direct-sales, or cooperatives marketing covered or non-covered edible horticultural products. Individuals engaged or entering commercial marketing, with commodities and practices covered in this manual, are strongly advised to carefully review the materials and make adoption and implementation decisions cognizant of regulatory and audit standards for qualified suppliers in the destination country(ies).

The PTC gives no expressed or implied warranties, including but not limited to, any warranties of merchantability or fitness for a particular purpose or use of commodities produced, stored, shipped, or marketed following practices or technologies described or cited in this manual.

Trevor Suslow, Ph.D.  
Director, Postharvest Technology Center  
5 December 2016

## **Users' Feedback Solicited**

The Postharvest Technology Center welcomes suggestions for additions to this manual and for changes in the materials included in this edition and will include such changes in the next edition. Please send your correspondence by mail or e-mail directly to:

Postharvest Technology Center  
Department of Plant Sciences, University of California, Davis  
postharvest@ucdavis.edu

Thank you for your cooperation and assistance.

# **Table of Contents**

---

|   |           |
|---|-----------|
| <b>Acknowledgments .....</b>  | <b>i</b>  |
| <b>Table of Contents .....</b>  | <b>iv</b> |
| <b>Introduction to the Manual .....</b>                                       | <b>1</b>  |
| Principal Causes of Postharvest Losses and Poor Quality .....                 | 4         |
| Principal Causes of Postharvest Losses and Poor Quality by Type of Crop ..... | 5         |
| Relative Perishability and Storage Life of Fresh Produce .....                | 6         |
| Produce Facts .....   | 7         |
| Resources for Quality Assurance and Export Marketing .....                    | 8         |
| <b>Chapter 1: Harvesting and Preparation for Market .....</b>                 | <b>10</b> |
| Best Practices for Harvesting .....   | 13        |
| Maturity Standards .....  | 14        |
| Using a Refractometer .....   | 16        |
| Using a Firmness Tester .....   | 17        |
| Harvesting Practices .....  | 18        |
| Harvesting Containers .....   | 20        |
| Harvesting Tools .....  | 22        |
| Field Packing .....   | 27        |
| Transport to the Packinghouse .....   | 30        |
| <b>Chapter 2: Curing Root, Tuber and Bulb Crops .....</b>                     | <b>31</b> |
| Field Curing .....  | 32        |
| Curing with Heated Air .....  | 34        |
| Bulk Systems for Curing Onions .....  | 35        |
| Emergency Curing .....  | 36        |
| <b>Chapter 3: Packinghouse Operations .....</b>                               | <b>37</b> |
| Best Practices for Packinghouse Operations .....                              | 40        |
| Narrow Pallet System .....  | 41        |
| General Operations .....  | 42        |
| Packinghouse Layout .....   | 43        |
| Dumping .....   | 44        |
| Conveyor Equipment .....  | 46        |
| Washing .....   | 47        |
| Waxing .....  | 50        |
| Sorting .....   | 51        |
| Sizing .....  | 56        |
| Simple Packing Line .....   | 61        |
| <b>Chapter 4: Packing and Packaging Materials .....</b>                       | <b>63</b> |
| Best Practices for Packing and Packaging .....                                | 65        |
| Packing Practices .....   | 67        |
| Packing Containers .....  | 71        |
| Choosing a Container .....  | 81        |
| Packaging Practices .....   | 84        |

|   |            |
|---|------------|
| Labeling .....  | 88         |
| Modularization of Containers .....                                  | 89         |
| Modified Atmosphere Packaging (MAP) .....                           | 91         |
| Unit loads .....  | 94         |
| <b>Chapter 5: Decay and Insect Control .....</b>                    | <b>95</b>  |
| Best Practices for Postharvest Pest Management.....                 | 96         |
| Chemical Controls .....   | 98         |
| Vase Life of Cut Flowers .....                                      | 104        |
| Cold Treatments .....   | 105        |
| Controlled/modified atmosphere treatments .....                     | 106        |
| Heat Treatments.....  | 108        |
| Biological Control and Plant Growth Regulators.....                 | 110        |
| <b>Chapter 6: Temperature and Relative Humidity Control.....</b>    | <b>111</b> |
| Best practices for managing temperature and relative humidity ..... | 113        |
| Room Cooling.....   | 115        |
| Forced-air Cooling (See also the USDA Portacooler on page 202)..... | 116        |
| Hydro-cooling .....   | 120        |
| Evaporative Cooling .....   | 122        |
| Night Air Ventilation .....   | 129        |
| Chilling Injury .....   | 130        |
| Use of Ice .....  | 132        |
| Alternative Methods of Cooling.....                                 | 134        |
| Increasing Relative Humidity .....                                  | 135        |
| Maintaining the Cold Chain for Perishables.....                     | 136        |
| <b>Chapter 7: Storage of Horticultural Crops .....</b>              | <b>137</b> |
| Best practices for storage of fresh fruits and vegetables .....     | 139        |
| Recommended storage temperatures .....                              | 140        |
| Compatibility groups for storage of fruits and vegetables .....     | 146        |
| Susceptibility to Freezing Injury.....                              | 149        |
| Storage Practices .....   | 150        |
| Storage Structures.....   | 155        |
| Storage of Dried and Bulb Crops.....                                | 174        |
| Storage of Root and Tuber Crops.....                                | 176        |
| Storage of Potatoes.....  | 177        |
| Controlled Atmosphere (CA) Storage .....                            | 181        |
| <b>Chapter 8: Transportation of Horticultural Crops .....</b>       | <b>194</b> |
| Best Practices For Transport.....                                   | 195        |
| Open Vehicles .....   | 198        |
| USDA Portacooler .....  | 201        |
| Refrigerated Trailers.....  | 202        |
| Stacking Patterns/Hand-stacked .....                                | 204        |
| Stacking Patterns/Pallet and Slip Sheet loads.....                  | 208        |
| Stacking Strength .....   | 209        |
| Bracing the Load .....  | 210        |
| Air Transport.....  | 212        |

|  |            |
|--|------------|
| <b>Chapter 9: Handling at Destination .....</b>                    | <b>213</b> |
| Best practices for destination handling .....                      | 214        |
| Unloading .....  | 215        |
| Temporary Storage Temperatures .....                               | 218        |
| Sorting/Repacking .....  | 220        |
| Ripening .....   | 222        |
| Display.....   | 230        |
| <b>Chapter 10: Processing of Horticultural Crops .....</b>         | <b>233</b> |
| Processing Equipment.....  | 234        |
| Preparation for Processing .....                                   | 236        |
| Solar Drying.....  | 239        |
| Forced-air Dehydrators.....  | 245        |
| Oil-burning Dehydrators .....                                      | 245        |
| Electric Dehydrators .....   | 247        |
| Oven Drying.....   | 248        |
| Drying Flowers.....  | 250        |
| Canning .....  | 252        |
| Juicing .....  | 255        |
| Other Methods of Processing .....                                  | 256        |
| <b>Chapter 11: Food Safety Practices .....</b>                     | <b>258</b> |
| Food Safety on the Farm.....                                       | 260        |
| Minimizing Pathogen Contamination During Harvest .....             | 262        |
| Minimizing Pathogen Contamination During Postharvest Handling..... | 263        |
| Sanitizing Field Containers, Tools and Packhouse Surfaces .....    | 265        |
| Traceback.....   | 266        |
| For further information .....                                      | 267        |
| <b>General References .....</b>                                    | <b>268</b> |
| <b>Appendix A .....</b>  | <b>273</b> |



## **Introduction to the Manual**

The three main objectives of applying postharvest technology to harvested fruits and vegetables are:

- 1) To maintain quality (appearance, texture, flavor and nutritive value),
- 2) To protect food safety, and
- 3) To reduce losses between harvest and consumption.

Effective management during the postharvest period, rather than the level of sophistication of any given technology, is the key in reaching the desired objectives. While large-scale operations may benefit from investing in costly handling machinery and high-tech postharvest treatments, often these options are not practical for small-scale handlers. Instead, simple, low-cost technologies often can be more appropriate for small volume, limited resource commercial operations, farmers involved in direct marketing, as well as for suppliers to exporters in developing countries.

Since the first edition of this manual was first published, the number of small farms and active farmer's markets in the USA has been steadily on the rise. According to the USDA-AMS, the number of farmers markets increased from 1,755 in 1994 to 7,175 in 2011. "Buy Fresh-Buy Local" campaigns are common in many cities, and the USDA is actively promoting farmers markets for urban areas and advocating for US citizens to eat more fruits and vegetables via a "5-a-day" program.

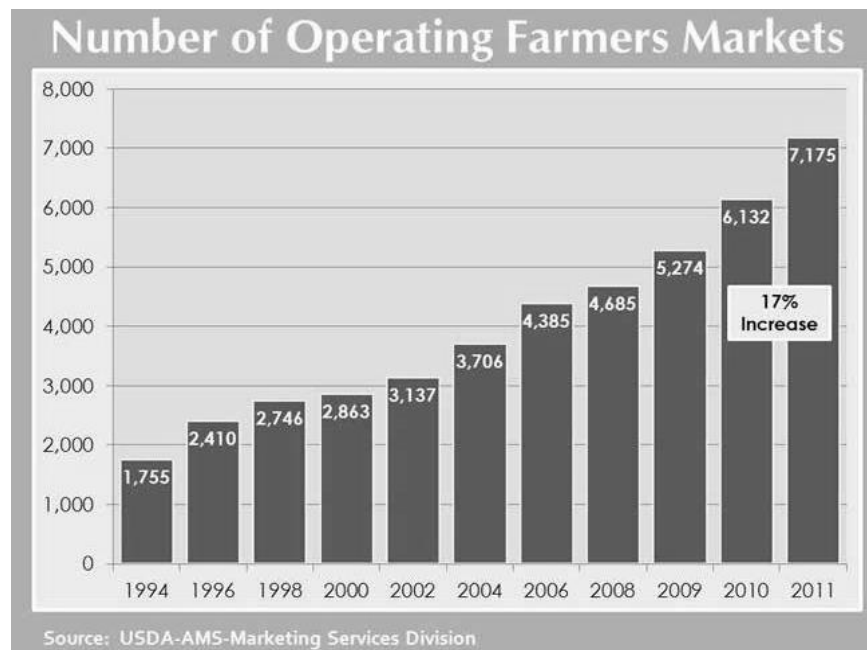

Although some of the recent innovations in postharvest technology in developed countries have been in response to the desire to avoid the use of costly labor and the

desire for cosmetically "perfect" produce, these methods may not be sustainable over the long term due to socioeconomic, cultural and/or environmental concerns.

For example, while the use of postharvest pesticides may reduce the incidence of surface defects, they can be expensive both in terms of cost and environmental consequences. Currently, the growing demand for organically produced fruits and vegetables offers new opportunities for small-scale producers and marketers who sell locally to restaurants or supermarkets, or those who choose to get involved in direct marketing to consumers.

Local conditions for small-scale handlers may include labor surpluses, lack of credit for investments in postharvest technology, unreliable electric power supply, lack of transport options, storage facilities and/or packaging materials, as well as a host of other constraints. Fortunately, there is a wide range of simple postharvest technologies from which to choose, and many practices have the potential of meeting the special needs of small-scale food handlers and marketers. Many of the practices included in the manual have successfully been used to reduce losses and maintain produce quality of horticultural crops in various parts of the world for many years.

This manual will assist you to identify and utilize scale-appropriate, cost-effective postharvest technologies for handling fresh horticultural produce to:

- Reduce postharvest losses due to water and weight loss, decay and physical damage
- Maintain produce quality (color, flavor, texture, appearance, nutritional value, etc.) and economic value during postharvest handling, storage and transport
- Increase shelf life with proper temperature and relative humidity management
- Assure food safety during fresh handling
- Increase income by adopting those postharvest technologies that are most profitable for your small-scale operations.

There are many interacting steps involved in any postharvest system. Produce is often handled by many different people, transported and stored repeatedly between harvest and consumption. While particular practices and the sequence of operations will vary for each crop, there is a general series of steps in postharvest handling systems that will be followed for the purposes of the manual.

Chapter 1 presents some of the harvesting practices and methods for preparation of fresh produce for market. Chapter 2 provides selected examples of how to cure root, tuber and bulb crops before further handling or storage. Chapter 3 illustrates simple technologies that can be used in packinghouse operations, be it a simple shed in the field or a separate structure with integrated cooling and storage facilities.

Chapter 4 presents a variety of improved packing methods and packaging materials that can help to maintain product quality and reduce mechanical damage during handling, transport and storage. Chapter 5 describes postharvest pest control methods and offers suggestions for alternatives to chemical treatments for insect and disease control.

Simple methods for cooling produce including the use of shade, evaporative cooling, hydro-cooling and forced-air cooling are described in Chapter 6. Storage structures, methods for ensuring adequate ventilation, and simple technologies for modified atmosphere storage are presented in Chapter 7. Transport practices that can reduce losses are described in Chapter 8, and methods for handling at destination (wholesale or retail markets) are illustrated in Chapter 9. Chapter 10 presents some simple methods for processing fresh produce and adding value by drying, canning or juice extraction. Finally, Chapter 11 describes the basics of Good Agricultural Practices (GAP) and simple methods that can be applied to ensure food safety when handling fresh produce.

Each of the practices presented in the manual are briefly described and illustrated. For further information on any particular practice, users can refer to the sources listed or contact the authors of the manual via email. The practices described in this manual are not meant to be a comprehensive list of postharvest handling practices, but a starting point for low-input and/or small-scale handlers of horticultural commodities. We suggest that you try the practices and compare them to your current practice. Remember that any of the practices may be modified by handlers to better suit local conditions or the materials available. And it is our hope that users of the manual will send to the authors any information about practical, low-cost technologies currently in use which were not covered in this edition.

We believe that application of some of the simple practices illustrated in the manual will enable small-scale handlers to reduce produce losses, protect food safety and help maintain quality of fruits, vegetables and ornamental crops.

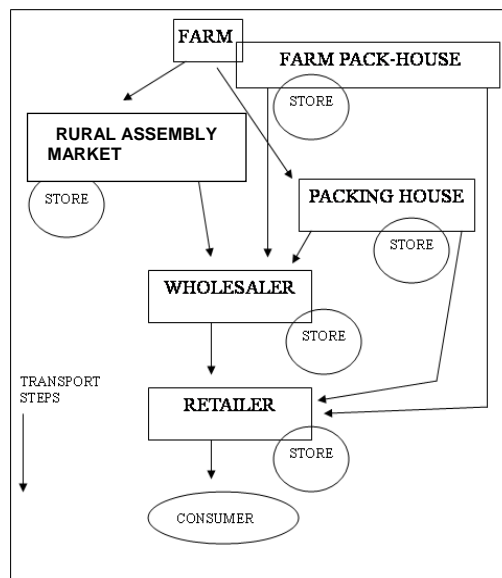

**Postharvest Handling Steps for a Typical Commodity**

## Principal Causes of Postharvest Losses and Poor Quality

Despite decades of educational efforts, the most common causes of postharvest losses in developing countries continue to be rough handling and inadequate cooling and temperature maintenance. The lack of sorting to eliminate defects before storage and the use of poor quality packages and packaging materials further add to the problem. In general, minimizing rough handling and using protective containers to reduce bruising and mechanical damage, sorting to remove damaged and diseased produce, and effective temperature management will help considerably to maintain a quality product and to reduce food losses. Storage life will be enhanced if the temperature during the postharvest period is kept as close to the optimum as feasible for a given commodity.

### IMPORTANT TYPES OF POSTHARVEST HORTICULTURAL LOSSES, QUALITY DETERIORATION AND FOOD SAFETY PROBLEMS ENCOUNTERED BY PRODUCE HANDLERS AND MARKETERS

|  |  |
|--|--|
| <b>Problems:</b>   |  |
| Water loss (weight loss)                                       | Shriveling, wilting of fruits and vegetables   |
| Water loss (loss of textural quality)                          | Softening, limpness, loss of crispiness or juiciness   |
| Mechanical damage  | Bruises, cuts, surface abrasions or crushing   |
| Physical losses due to pests                                   | Fungal and bacterial diseases, insect attack   |
| Contamination  | Soil, pathogenic bacteria (soil-borne disease)<br>Pesticide and chemical residues  |
| Losses from physiological disorders due to temperature         | Chilling injury, freezing injury, heat injury, sunburn   |
| Losses from physiological disorders due to nutrient imbalances | Calcium deficiency (bitter pit, blossom end rot), Boron toxicity   |
| Losses from physiological disorders due to atmospheric gases   | Damage from ethylene (russet spotting, softening, induced browning), low oxygen, high carbon dioxide, or refrigerant gas leaks (ammonia)   |
| Losses due to continued growth and development after harvest   | Rooting, sprouting, shoot development, elongation and curvature of asparagus, greening of potatoes, fiber development, seed germination inside fruits, compositional changes (loss of color, flavor, firmness) |
| Nutritional losses   | Loss of stored carbohydrates, vitamin C  |

## Principal Causes of Postharvest Losses and Poor Quality by Type of Crop

| GROUP                                 | EXAMPLES   | PRINCIPAL CAUSES OF POSTHARVEST LOSSES AND POOR QUALITY (IN ORDER OF IMPORTANCE) |
|---------------------------------------|--|--|
| Root vegetables                       | Carrots<br>Beets<br>Onions<br>Garlic<br>Potato<br>Sweet<br>Potato                    | Mechanical injuries  |
|                                       |  | Improper curing  |
|                                       |  | Sprouting and rooting  |
|                                       |  | Water loss (shriveling)  |
|                                       |  | Decay  |
|                                       |  | Chilling injury (subtropical and tropical root crops)                            |
|                                       |  |  |
| Leafy vegetables                      | Lettuce<br>Chard<br>Spinach<br>Cabbage<br>Green<br>onions                            | Water loss (wilting)   |
|                                       |  | Loss of green color (yellowing)  |
|                                       |  | Mechanical injuries  |
|                                       |  | Relatively high respiration rates  |
|                                       |  | Decay  |
| Flower vegetables                     | Artichokes<br>Broccoli<br>Cauliflower  | Mechanical injuries  |
|                                       |  | Yellowing and other discolorations   |
|                                       |  | Abscission of florets  |
|                                       |  | Decay  |
| Immature-fruit<br>vegetables          | Cucumbers<br>Squash<br>Eggplant<br>Peppers<br>Okra<br>Snap beans                     | Over-maturity at harvest   |
|                                       |  | Water loss (shriveling)  |
|                                       |  | Bruising and other mechanical injuries   |
|                                       |  | Chilling injury  |
|                                       |  | Decay  |
| Mature-fruit<br>vegetables and fruits | Tomato<br>Melons<br>Citrus<br>Bananas<br>Mangoes<br>Apples<br>Grapes<br>Stone fruits | Bruising   |
|                                       |  | Over-ripeness and excessive softening at harvest                                 |
|                                       |  | Water loss   |
|                                       |  | Chilling injury (chilling sensitive fruits)                                      |
|                                       |  | Compositional changes  |
|                                       |  | Decay  |

## Relative Perishability and Storage Life of Fresh Produce

Classification of fresh horticultural crops according to their relative perishability and potential storage life in air at near optimum temperature and relative humidity

| RELATIVE PERISHABILITY | POTENTIAL STORAGE LIFE (WEEKS) | COMMODITIES  |
|------------------------|--------------------------------|--|
| Very high              | <2                             | Apricot, blackberry, blueberry, cherry, fig, raspberry, strawberry; asparagus, bean sprouts, broccoli, cauliflower, green onion, leaf lettuce, mushroom, muskmelon, pea, spinach, sweet corn, tomato (ripe); most cut flowers and foliage; minimally processed fruits and vegetables.                      |
| High                   | 2-4                            | Avocado, banana, grape (without SO <sub>2</sub> treatment), guava, loquat, mandarin, mango, melons (honeydew, Crenshaw, Persian), nectarine, papaya, peach, plum; artichoke, green beans, Brussels sprouts, cabbage, celery, eggplant, head lettuce, okra, pepper, summer squash, tomato (partially ripe). |
| Moderate               | 4- 8                           | Apple and pear (some cultivars), grape (SO <sub>2</sub> -treated), orange, grapefruit, lime, kiwifruit, persimmon, pomegranate; table beet, carrot, radish, potato (immature).   |
| Low                    | 8-16                           | Apple and pear (some cultivars), lemon; potato (mature), dry onion, garlic, pumpkin, winter squash, sweet potato, taro, yam; bulbs and other propagules of ornamental plants.  |
| Very low               | >16                            | Tree nuts, dried fruits and vegetables.  |

Source: Kader, A.A, 1993. Postharvest Handling. In: Preece, J.E. and Read, P.E., The Biology of Horticulture- An Introductory Textbook. New York: John Wiley & Sons. pp. 353-377.

## Produce Facts

The UC Davis Postharvest Technology Center website provides “Produce Facts”, with detailed information and recommendation for many fresh horticultural crops. Produce Facts are available online in English, Spanish, French and Arabic.  
[http://postharvest.ucdavis.edu/Commodity\\_Resources/Fact\\_Sheets/](http://postharvest.ucdavis.edu/Commodity_Resources/Fact_Sheets/)

One example is provided here:

[Return to Fact Sheet](#)

### Sweet Potato

#### Recommendations for Maintaining Postharvest Quality



**Ask the Produce Docs for this Commodity**

**Publications for this Commodity**

*Marita Cantwell and Trevor Suslow*

*Department of Plant Sciences, University of California, Davis*

#### Maturity & Quality

##### General Information

The sweet potato (*Ipomoea batatas*) is a warm season root crop. Moist, sweet flesh types of sweetpotatoes are sometimes called "yams", but these should not be confused with true yams (*Dioscorea* sp.). Cultivars with high orange-colored flesh contain much higher levels of carotenoids than less pigmented types. Sweet potato flavor is largely based on starch and sugar concentrations, and these are affected by cultivars and storage conditions.

##### Maturity Indices

Sweet potatoes are harvested when roots have reached the desirable size. Irrigation is typically stopped 2 to 3 weeks before harvest so that vines begin drying before they are removed and roots are harvested.

##### Quality Indices

Good quality sweet potatoes should be smooth and firm, with uniform shape and size, be free from mechanical damage, and have a uniform peel color typical of the variety.

There are four U.S. Grades for sweet potato (U.S. Extra No. 1, U.S. No.1, U.S. commercial and U.S. No. 2), and grades are based on degree of freedom from defects (dirt, roots, cuts, bruises, growth cracks, decay, insects, and diseases), but also size and weight categories.

For the full Produce facts sheet, visit  
[http://postharvest.ucdavis.edu/Commodity\\_Resources/Fact\\_Sheets/Datastores/Vegetables\\_English/?uid=34&ds=799](http://postharvest.ucdavis.edu/Commodity_Resources/Fact_Sheets/Datastores/Vegetables_English/?uid=34&ds=799)

## Resources for Quality Assurance and Export Marketing

While it is likely that most of the users of this manual will be producing for local or regional domestic markets, the following information is provided for those users who may be interested in learning more about export marketing. Export markets require adherence to strictly set grades and standards, use of proper packaging materials, proper cooling and cold chain management, and documentation of the maintenance of international food safety standards.

Standards for U.S. Grades are available for a wide range of fruits and vegetables for fresh market or processing. For a single free copy of U.S. Grades for a particular commodity, write to Fresh Products Branch, USDA-AMS, FV, Room 2056-S, Washington, D.C., 20250. U.S. Inspection Instructions are also available at a small fee from this address. Grade Standards can also be downloaded from the **USDA-AMS** (Fruit & Vegetable Programs) website:  
<https://www.ams.usda.gov/grades-standards>

The Organization of Economic Cooperation and Development (**OECD**) publishes booklets on "International Standards of Fruits and Vegetables". In North America, write to: OECD Publications and Information Center, 2001 L Street, N.W., Suite 700, Washington, D.C., 20036-4910. From countries outside North America, contact OECD Publications Service, 2 Rue André-Pascal, 75775 PARIS Cedex 16, France. Food safety is a top priority for many growers, produce buyers and retailers, and global Good Agricultural Practices (GAP) are in wide use. Beginning as an initiative by retailers in 1997, the Euro-Retailer Produce Working Group (**EUREP**) developed and tested the first EUREP-GAP protocols, now referred to as Global-GAP. ([http://www.globalgap.org/uk\\_en/](http://www.globalgap.org/uk_en/))

The mission of the Animal and Plant Health Inspection Service (**APHIS**) is "to protect America's animal and plant resources by:

- Safeguarding resources from exotic invasive pests and diseases,
- Monitoring and managing agricultural pests and diseases existing in the United States,
- Resolving and managing trade issues related to animal or plant health, and
- Ensuring the humane care and treatment of animals."

The APHIS website (<https://www.aphis.usda.gov/aphis/home/>) offers a wide variety of information related to import/export regulations of concern to those interested in exporting produce to the United States.

- [http://www.aphis.usda.gov/import\\_export/plants/manuals/index.shtml](http://www.aphis.usda.gov/import_export/plants/manuals/index.shtml) displays a list of APHIS/Plant Protection and Quarantine Manuals that are available electronically.
- [http://www.aphis.usda.gov/import\\_export/plants/manuals/ports/downloads/fv.pdf](http://www.aphis.usda.gov/import_export/plants/manuals/ports/downloads/fv.pdf) is a complete handbook on "Fresh Fruits and Vegetables Import Manual" that is available online.



**Protrade** advises and promotes businesses in Latin America, Africa, Asia and Eastern Europe by providing marketing expertise for products that are competitive in European markets. Handbooks on general trade and marketing are available for fresh fruit and dried fruit. Export manuals (in English and Spanish) are available for asparagus, mangoes, avocados, papaya and pineapple. These publications are available from Deutsche Gesellschaft für Technische Zusammenarbeit (GTZ), GmbH/Protrade, P.O. Box 5180, D-65726 Eschborn, Germany.

**ASEAN Food Handling Bureau** has developed publications on the harvesting, postharvest handling and marketing of banana, mango, rambutan, papaya and durian as a part of its series on "Fruit Development, Postharvest Physiology, Handling and Marketing in ASEAN". Each book is available for sale from ASEAN Food Handling Bureau, Level 3, G14/G15, Pusat Bandar Damansara, 50490 Kuala Lumpur, Malaysia.

The **Produce Marketing Association**, founded in 1949, is a not-for-profit global trade association serving over 2,400 members who market fresh fruits, vegetables, and related products worldwide. Its members are involved in the production, distribution, retail, and foodservice sectors of the industry.  
([www.pma.com](http://www.pma.com))

## **Chapter 1: Harvesting and Preparation for Market**

Small-scale producers have the option to **harvest earlier** when vegetables are more delicate and valuable, **harvest later** when fruits are at a riper, more flavorful stage; **or harvest more often** (taking advantage of multiple harvests to gather produce at its optimum stage of maturity). All these options can lead to higher profits due to the higher value of the produce you have to offer for sale.

One of the most common mistakes growers make is to harvest fruit crops too early when they are under-ripe and have not yet developed their full flavor. Some vegetables, if allowed to grow large, will be too fibrous or full of seeds for good eating quality. With many horticultural crops, if you harvest all at once, you are sure to have many items that are either under-mature or over-mature. Using a maturity index as a standard will greatly reduce pre-sorting losses. For some crops this involves using a refractometer to measure soluble solids (mostly sugars) or a penetrometer to measure firmness.

Mechanical damage during harvest can become a serious problem. Injuries predispose produce to decay, increased water loss and increased respiratory and ethylene production rates, leading to quick deterioration. In general, harvesting by machine will cause more damage than harvesting by hand, although some root crops can be severely damaged by careless hand digging. The containers used by pickers in the field should be clean, have smooth inside surfaces and be free of rough edges. Stackable plastic crates, while initially expensive, are durable, reusable and easily cleaned (FAO, 1989). If baskets must be used, they should be woven "inside out" with the stubs of the beginning and end of each cane on the outside of the basket (Grierson, 1987). Using smaller containers will also help to reduce damage and postharvest losses (Kitinoja, 2012).

Manual harvesters should be well trained in the proper way to harvest the crop to minimize damage and waste, and should be able to recognize the proper maturity stage for the produce they are handling. Pickers should harvest with care by snapping, cutting or pulling the fruit or vegetable from the plant in the least damaging manner. The tips of knives should be rounded to minimize inadvertent gouges and excess damage to perennial plants. Knives and clippers should always be well sharpened. Pickers should be trained to empty their picking bags and/or baskets with care, never dumping or throwing produce into field containers. If harvesters pick directly into large bulk bins, produce can be protected from bruising by the use of a de-accelerating chute fashioned from canvas. Vented, stackable field containers should be kept clean and smooth.

Exposure to the sun should be avoided as much as possible during and after harvest, as produce left out in the sun will gain heat and may become sun-burned. Produce exposed to sunlight can soon become 4 to 6 °C (7 to 11 °F) warmer than air temperature (Thompson et al., 2001). Field bins should be placed in the shade or

loosely covered (for example with light-colored canvas, leafy plant materials, straw, or an inverted empty container) if delays are expected in removing them from the field. Night or early morning harvest is sometimes an option for harvesting produce when internal temperatures are relatively low, reducing the energy needed for subsequent cooling. Latex flow is often lower later in the morning than it is at dawn for crops such as mango and papaya (Pantastico, 1980). Therefore, harvesting as late in the morning as possible can reduce later efforts required to clean the produce before packing. Also, citrus fruits should not be harvested early in the morning when turgid because of their greater susceptibility to the release of essential oils from the flavedo oil glands that cause oil spotting (green spots on yellow and orange citrus fruits after degreening).

Directly following harvest, when produce is prepared for marketing, cooling is essential. Cooling (also known as "pre-cooling") is the removal of field heat directly after harvest, before any further handling. Any delays in cooling will shorten postharvest life and reduce quality. Even produce undergoing repeated cooling and warming deteriorates at a slower rate than produce that has not been cooled (Mitchell et al., 1972).

Rough handling during preparation for markets will increase bruising and mechanical damage and limit the benefits of cooling. Roads between the field and the packinghouse should be graded and free from large ruts, bumps and holes. Field boxes must be well secured during transport and, if stacked, not overfilled. Transport speeds must be suited to the quality and conditions of the roads, and truck and/or trailer suspensions kept in good repair. Reduced tire air pressure on transport vehicles will reduce the amount of motion transmitted to the produce (as cited in Kader, 2002).

Any practice that reduces the number of times the produce is handled will help reduce losses. Field packing (selection, sorting, trimming and packaging of produce at the time of harvest) can greatly reduce the number of handling steps the produce must undergo before marketing. Small carts or small mobile field packing stations can be designed to be moved along with the packers and to provide shade for packing operations.

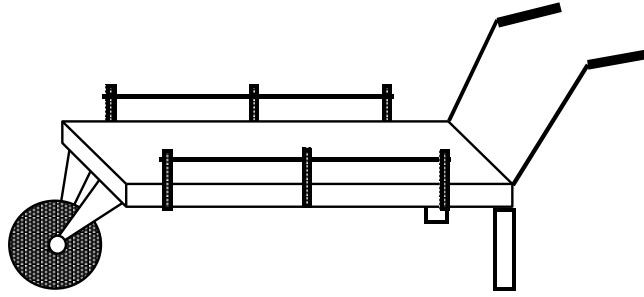

HAND CART: used for field packing. Harvesters place an empty carton on the cart, then pick, sort, grade and pack directly into the container. Filled cartons are moved immediately into coolers or kept in a well-shaded area.

## Best Practices for Harvesting

| <b>DO</b>   | <b>DO NOT</b>   |
|---|---|
| Always consider the needs and requirements of the market for your produce (customer preferences for size and/or stage of maturity).                 | Pick up produce that has fallen on the ground during harvesting.      |
| Regardless of commodity or development stage of produce, all horticultural products require extreme care at harvest.                                | Lay harvested produce or field containers on bare soil.               |
| Use containers that are clean, smooth and free of rough edges, vented, and not too large. Steel or plastic buckets make good harvesting containers. | Dump or throw produce into field containers.                          |
| Use stackable plastic crates as field containers during harvest--while initially expensive, these are durable, reusable and easily cleaned.         | Overfill containers especially if they are stacked.                   |
| Train harvest personnel in the proper way to harvest the crop to minimize damage and waste.   | Use field containers for any other purpose (tools, foods, fuel, etc.) |
| Train harvesters to recognize the proper maturity stage for the produce they are handling (such as size, shape, color, sweetness or firmness).      |   |
| Round the tips of knives to minimize inadvertent gouges and excess damage to perennial plants, sharpen knives and clippers.                         |   |
| Wear cotton gloves, trim fingernails, and remove jewelry such as rings and bracelets to help reduce mechanical damage during harvest.               |   |
| Train pickers to empty their picking bags and/or baskets with care.   |   |
| Keep produce clean and free from soil contamination to reduce food safety hazards.  |   |
| Always provide shade for harvested produce to prevent heat and sun damage.  |   |
| Let dew dry off in the morning if harvesting crops are susceptible to fungal diseases.  |   |
| Cool produce (remove field heat) as soon as possible after harvest.   |   |
| Grade roads between the field and the packinghouse and keep them free of large ruts, bumps and holes.   |   |
| Secure field boxes well during transport.   |   |
| Disinfect all tools and equipment that will come in contact with produce (use a solution of one part chlorine bleach to one part clean water).      |   |
| Consider field packing to reduce the number of times produce is handled between harvest and marketing.  |   |

## Maturity Standards

Maturity standards have been determined for many fruit, vegetable and floral crops. Harvesting crops at the proper maturity allows handlers to begin their work with the best possible quality produce. Produce harvested too early may lack flavor and may not ripen properly, while produce harvested too late may be fibrous or overripe. Pickers can be trained in methods of identifying produce that is ready for harvest. The following table, from Reid (as cited in Kader, 2002), provides some examples of maturity indices.

| Index                                   | Examples   |
|---|--|
| Elapsed days from full bloom to harvest | Apples, pears  |
| Mean heat units during development      | Peas, apples, sweet corn   |
| Development of abscission layer         | Some melons, apples, feijoas   |
| Surface morphology and structure        | Cuticle formation on grapes, tomatoes<br>Netting of some melons<br>Gloss of some fruits (development of wax) |
| Size                                    | All fruits and many vegetables   |
| Specific gravity                        | Cherries, watermelons, potatoes  |
| Shape                                   | Angularity of banana fingers<br>Full cheeks of mangos<br>Compactness of broccoli and cauliflower             |
| Solidity                                | Lettuce, cabbage, brussels sprouts   |
| Textural properties                     |  |
| Firmness                                | Apples, pears, stone fruits  |
| Tenderness                              | Peas   |
| Color, external                         | All fruits and most vegetables   |
| Internal color and structure            | Formation of jelly-like material in tomato fruits<br>Flesh color of some fruits                              |
| Compositional factors                   |  |
| Starch content                          | Apples, pears  |
| Sugar content                           | Apples, pears, stone fruits, grapes  |
| Acid content, sugar/acid ratio          | Pomegranates, citrus, papaya, melons, kiwifruit  |
| Juice content                           | Citrus fruits  |
| Oil content                             | Avocados   |
| Astringency (tannin content)            | Persimmons, dates  |
| Internal ethylene concentration         | Apples, pears  |

Source: Kader, A. A. 1983. Postharvest Quality Maintenance of Fruits and Vegetables in Developing Countries. In: Lieberman, M., Post-Harvest Physiology and Crop Preservation. Plenum Publishing Corporation. p. 455-469.

Vegetables are harvested over a wide range of maturities depending on the part of the plant used as food. The following table provides some examples of maturity indices of vegetable crops.

| Crop   | Index  |
|--|--|
| <b>Root, bulb and tuber crops</b>                                    |  |
| Radish and carrot  | Large enough and crispy (over-mature if pithy)   |
| Potato, onion, and garlic  | Tops beginning to dry out and topple down  |
| Yam bean and ginger  | Large enough (over-mature if tough and fibrous)  |
| Green onion  | Leaves at their broadest and longest   |
| <b>Fruit vegetables</b>  |  |
| Cowpea, yard-long bean, snap bean, batao, sweet pea, and winged bean | Well-filled pods that snap readily   |
| Lima bean and pigeon pea   | Well-filled pods that are beginning to lose their greenness  |
| Okra   | Desirable size reached and the tips of which can be snapped readily  |
| Upo, snake gourd, and dishrag gourd                                  | Desirable size reached and thumbnail can still penetrate flesh readily (over-mature if thumbnail cannot penetrate flesh readily) |
| Eggplant, bitter melon, chayote or slicing cucumber                  | Desirable size reached but still tender (over-mature if color dulls or changes and seeds are tough)                              |
| Sweet corn   | Exudes milky sap from kernel if cut  |
| Tomato   | Seeds slipping when fruit is cut, or green color turning pink  |
| Sweet pepper   | Deep green color turning dull or red   |
| Muskmelon  | Easily separated from vine with a slight twist leaving clean cavity  |
| Honeydew melon   | Change in fruit color from a slight greenish white to cream; aroma noticeable  |
| Watermelon   | Color of lower part turning creamy yellow, dull hollow sound when thumped  |
| <b>Flower vegetables</b>   |  |
| Cauliflower  | Curd compact (over-mature if flower cluster elongates and becomes loose)   |
| Broccoli   | Bud cluster compact (over-mature if loose)   |
| <b>Leafy vegetables</b>  |  |
| Lettuce  | Big enough before flowering  |
| Cabbage  | Head compact (over-mature if head cracks)  |
| Celery   | Big enough before it becomes pithy   |

Source: Bautista, O.K. and Mabesa, R.C. (eds). 1977. Vegetable Production. University of the Philippines at Los Banos.

Additional detailed maturity indices for fruits, vegetables and cut flowers can be found online at <http://postharvest.ucdavis.edu> on a wide range of Produce Fact Sheets.

## Using a Refractometer

Sugars are the major soluble solids in fruit juices and, therefore, soluble solids can be used as an estimate of sweetness. A hand-held refractometer can be used outdoors to measure % SSC (equivalent degrees Brix for sugar solutions) in a small sample of fruit juice. Temperature will affect the reading (increasing about 0.5% SSC for every 5 °C or 10 °F), so you should adjust the measurement for the ambient temperature.

A garlic press works well to squeeze the juice from fruit samples. For small fruits, use the whole fruit. For large fruits, take a wedge from the stem end to the blossom end and to the center of the fruit. Remove any pulp by filtering the juice through a small piece of cheesecloth. You must clean and standardize the refractometer between each reading with distilled water (should read 0% SSC at 20 °C or 68 °F).

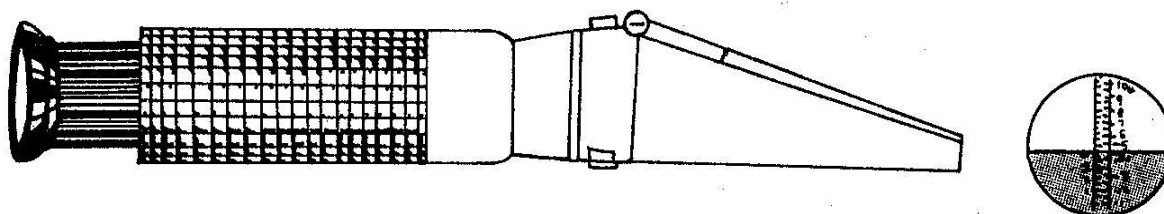

Here are some examples of proposed minimum % SSC for selected commodities. If your reading indicates a higher % SSC, then your produce is better than the minimum standard. Strawberries, which are of excellent flavor, for instance, would measure 8% SSC or above.

Minimum % SSC

|             |         |
|-------------|---------|
| Apricot     | 10      |
| Blueberry   | 10      |
| Cherry      | 14-16   |
| Grape       | 14-17.5 |
| Kiwifruit   | 6.5     |
| Mango       | 10-12   |
| Muskmelon   | 10      |
| Nectarine   | 10      |
| Papaya      | 11.5    |
| Peach       | 10      |
| Pear        | 13      |
| Pineapple   | 12      |
| Plum        | 12      |
| Pomegranate | 17      |
| Strawberry  | 7       |
| Watermelon  | 10      |

Sources: Kader, A.A. 1999. Fruit maturity, ripening and quality relationships. *Acta Hort* 485: 203-208. S. Vasquez and S. Mueller, 2008. Refractometer calibration, use and maintenance. <http://ucce.ucdavis.edu/files/datastore/234-1200.pdf>



## Using a Firmness Tester

The degree of softness or crispiness can be estimated by squeezing produce or taking a bite. Objective measurements can be made with inexpensive penetrometers. The most common way to measure firmness is resistance to compression or pounds-force (lbf). The Effe-gi fruit penetrometer is a hand-held probe with a gauge for pounds-force.

To measure firmness, use fruits that are uniform in temperature, since warm fruits are usually softer than cold fruits. Use fruits that are uniform in size, since large fruits are usually softer than smaller fruits. Make two puncture tests per fruit on larger fruits, once on opposite cheeks, midway between stem and blossom ends. Remove a disc of skin (larger than the tip to be used) and choose the appropriate plunger tip (see below). Hold the fruit against a stationary, hard surface, and force the tip into the fruit at a slow, uniform speed (take 2 seconds) to the scribed line on the tip. Take the reading to the nearest 0.5 lb.-force.

### **Appropriate Effe-gi plunger tip sizes to use when measuring firmness in selected fruits:**

|                    |  |
|--------------------|--|
| 1.5 mm (1/16 inch) | Olive  |
| 3 mm (1/8 inch)    | Cherry, grape, strawberry  |
| 8 mm (5/16 inch)   | Apricot, avocado, kiwifruit, pear, mango, nectarine, papaya, peach |
| 11 mm (7/16 inch)  | Apple  |

Calibrate firmness testers by holding the tester vertically and placing the tip on the pan of a scale. Press down until the scale registers a given weight, then read the firmness tester. Repeat three to five times. If you find the instrument reads the same as the scale, it is ready to use. You can adjust the penetrometers by inserting washers in the appropriate locations (follow the instructions that come with the instrument).

## Harvesting Practices

Harvesting practices should cause as little mechanical damage to produce as possible. Gentle digging, picking and handling will help reduce crop losses.

Pick carefully to avoid damage:

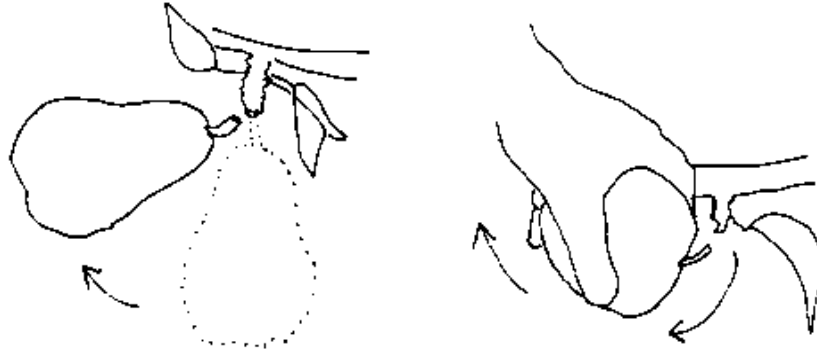

For some crops, a natural break point forms at the junction of the stem and the stalk when produce is mature. Harvesters should grasp the product firmly but gently and pull upward as illustrated below. Wearing cotton gloves, trimming fingernails, and removing jewelry such as rings and bracelets can help reduce mechanical damage during harvest.

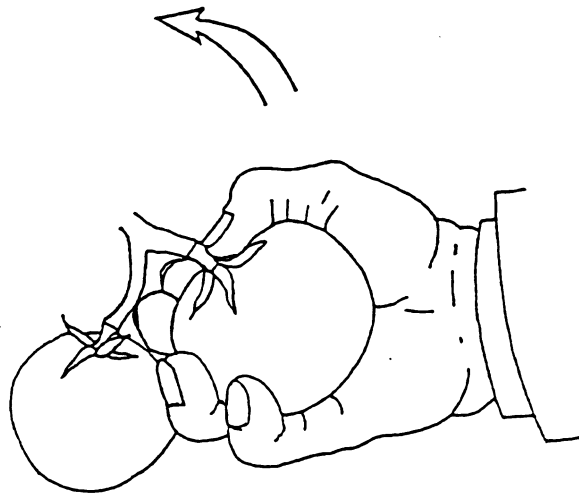

Source: FAO. 1989. Prevention of Post-Harvest Food Losses: Fruits, Vegetables and Root Crops. A Training Manual. Rome: UNFAO. p. 157.

If a small amount of leafy vegetables are being harvested for home use or for sale at a nearby roadside or farmers' market, a small tub of cold water can be useful for cooling the produce. The tub can be brought directly to the field and used by the picker as a field container. Clean water should be used with each lot of produce. Chilling leafy vegetables by using cold water at harvest will help maintain quality and prevent wilting.



Source: Minnich, J. 1983. Gardening for Maximum Nutrition. Emmaus, Pa: Rodale Press.

## Harvesting Containers

Picking baskets, bags and buckets come in many sizes and shapes. Buckets are better than baskets in protecting produce, since they do not collapse and squeeze produce.

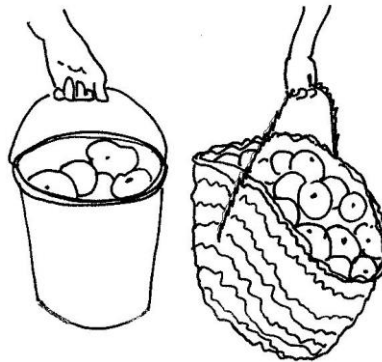

These harvesting containers can be made by sewing bags with openings on both ends, fitting fabric over the open bottom of ready-made baskets, fitting bags with adjustable harnesses, or simply adding some carrying straps to a small basket.

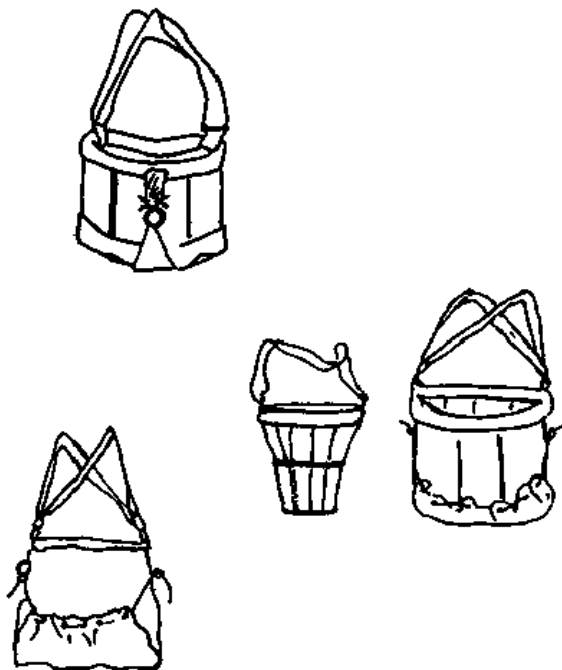

Source: Friend Manufacturing Corporation, Prospect Street, P.O. Box 385, Gasport, New York 14067.

Plastic crates are relatively expensive but are durable, reusable and easy to clean. When empty, they can be nested to save space in storage or transport. When filled, they can be stacked if every other crate is turned in the direction opposite to the one below.

Stackable, reusable plastic crates:

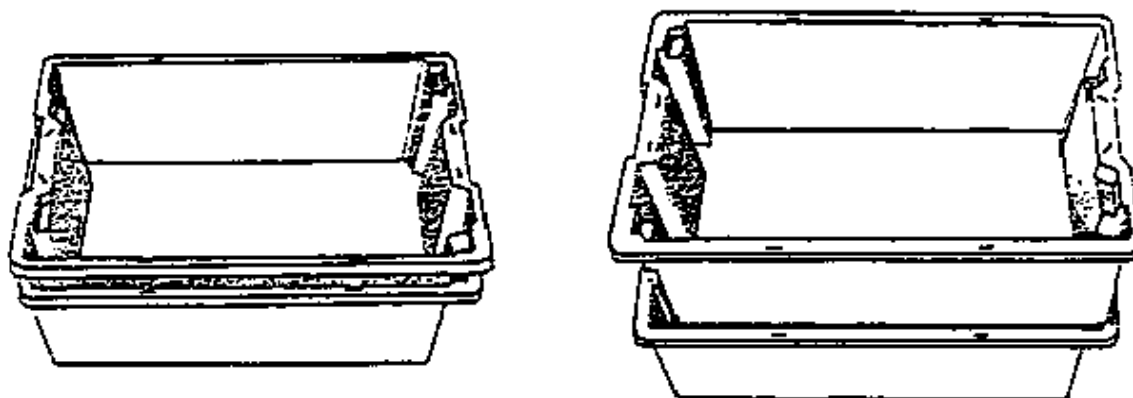

Source: FAO. 1989. Prevention of Post-Harvest Food Losses: Fruits, Vegetables and Root Crops. A Training Manual. Rome: UNFAO. p. 157.

If plastic crates are well vented along the sides and/or bottom, they can also be used to wash and/or cool produce after harvest. See Chapter 3 and 4 for more details.

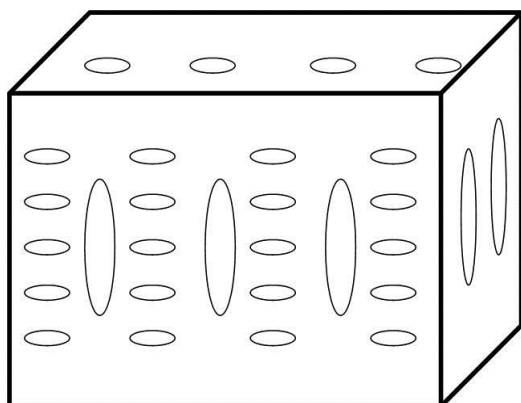

## Harvesting Tools

Some fruits need to be clipped or cut from the parent plant. Clippers or knives should be kept well sharpened. Harvesting tools should be kept clean, free from rust and extraneous materials by dipping them in sanitizing solution periodically during the day. Penduncles, woody stems or spurs should be trimmed as close as possible to prevent fruit from damaging neighboring fruits during transport.



Pruning shears are often used for harvesting fruits, some vegetables, and cut flowers. A wide variety of styles is available as handheld or pole models, including shears that cut and hold onto the stem of the cut product. This feature allows the picker to harvest without using a catching bag or dropping fruits.

Straight-bladed hand shears for fruits and flowers:



Thin, curved blade for grapes and fruits:

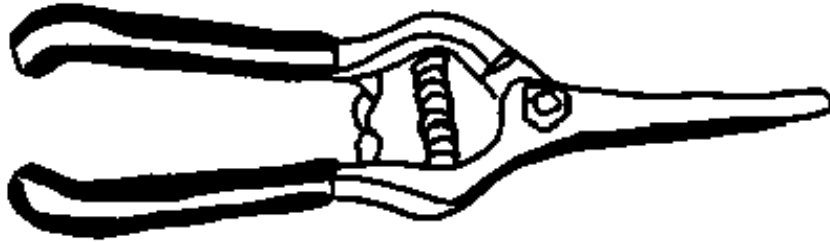

Cut and hold hand shears:

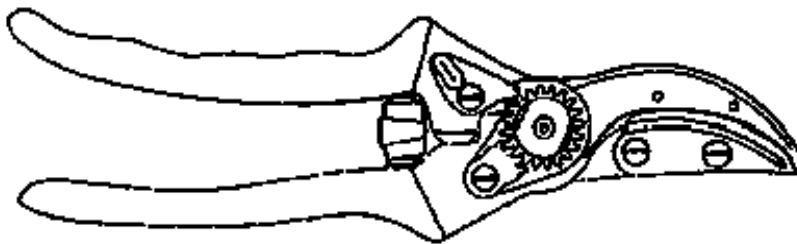

Clipper for citrus fruits:

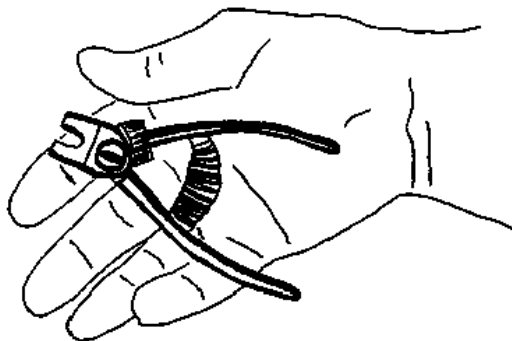

Pole mounted, cut and hold picking shears:

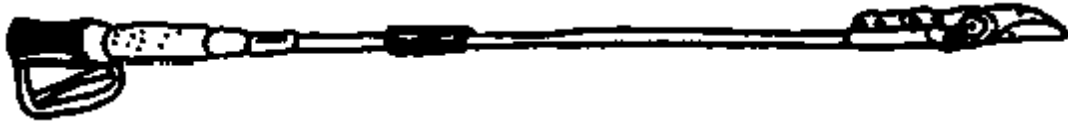

Using a cutting tool attached to a long pole can aid picking of crops, such as mangoes and avocados, when the fruit is difficult to reach. Cutting edges should be kept sharpened and the catching bag should be relatively small. The angle of the cutting edge and the shape of the catching bag can affect the quality of the fruit harvested, so it is important to check performance carefully before using any new tools.

Using a picking pole:

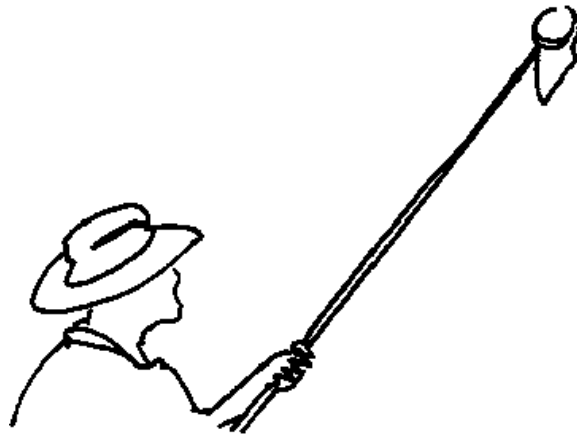



Picking poles and catching sacks can be made by hand or purchased from horticultural supply companies. The collection bags illustrated below were hand woven from strong cord or sewn from canvas. The hoop used as the basket rim and cutting edges can be fashioned from sheet metal, steel tubing or recycled scrap metal.

**Handwoven collection bag**

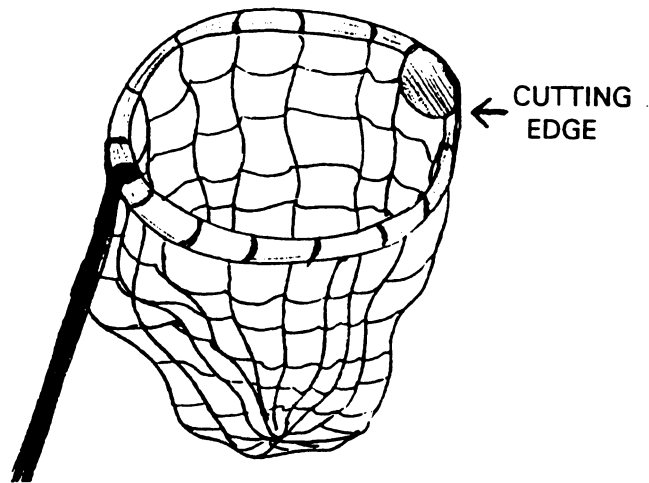

**Canvas collection sack**

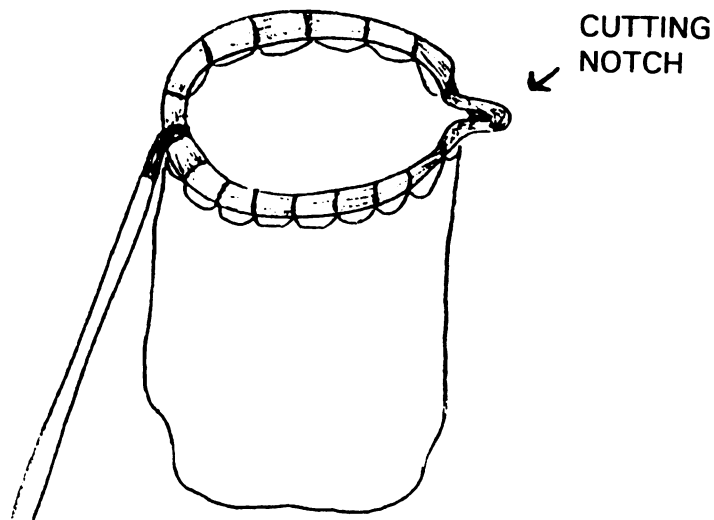

Fruit trees are sometimes quite tall and letting fruit fall to the ground when it is cut from the tree will cause severe bruising. If two pickers work together, one can clip or cut the fruit from the tree, and the other can use a sack to break its fall. The catcher supports the bag with his hands while one foot catches the falling fruit. Then he lowers the far end of the bag to allow the fruit to roll safely to the ground.

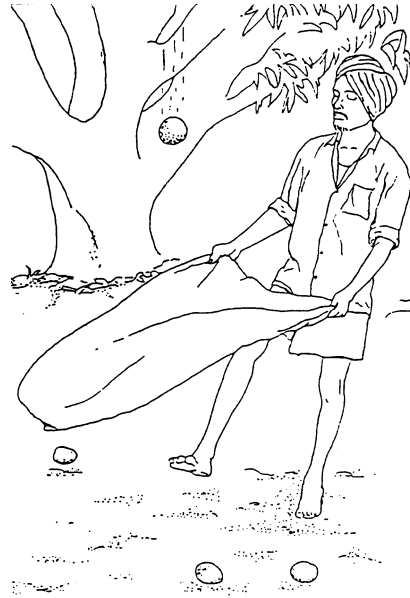

Source: FAO. 1989. Prevention of Post-Harvest Food Losses: Fruits, Vegetables and Root Crops. A Training Manual. Rome: UNFAO. p. 157.

Unlike most nut crops, pistachio nuts should not be knocked to the ground during harvest because of their open shells and relatively high moisture content. The harvesting practice illustrated below can be used with pistachios and olives with good results. Plastic sheeting or canvas tarpaulins are spread below the tree being harvested, and trees are mechanically shaken or hand knocked (the branches hit with mauls) until the nuts drop. In the illustration below, two harvesters are gathering a sheet covered with produce.



## Field Packing

When crops are field packed, the picker harvests and immediately packs the produce after minimal handling. Strawberries are generally field packed, since even a small amount of handling will damage these soft fruits. When lettuce is field packed, several wrapper leaves are left on the head to help cushion the produce during transport.

A small cart can help reduce the amount of bending and lifting the picker has to do during harvest. The carts shown below have a single wheel in front and can be pushed along the row ahead of the picker.

### Field Packing Strawberries:

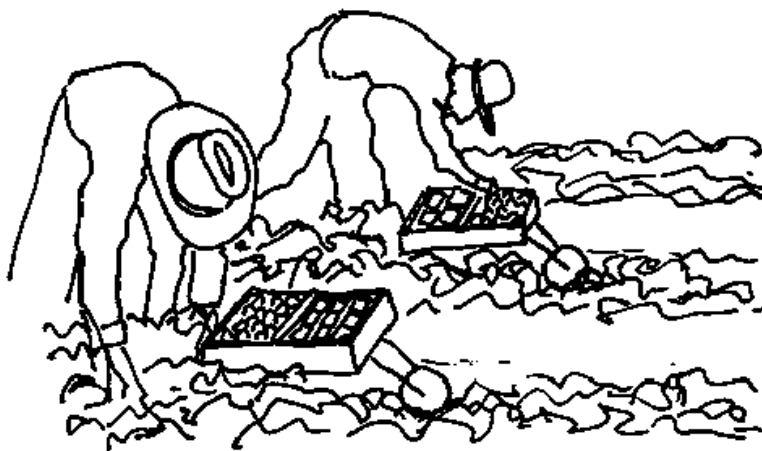

### Field Packing Lettuce:



A simple aid for field packers is a movable cart with a rack for boxes and a wide roof to provide shade. This small cart is designed to be pushed by hand along the outer edge of the field or orchard where the harvest is taking place. It has been used to field pack table grapes, small fruits and specialty vegetables.



This larger cart for field packing is designed to be pulled by a small tractor into the field when the crop is harvested. This type of cart can be used for field packing many types of crops. The roof folds down for easy transport and opens up to provide a wide area of shade for the packers and the commodity. The cart design can be modified as needed to suit various products and different operations.

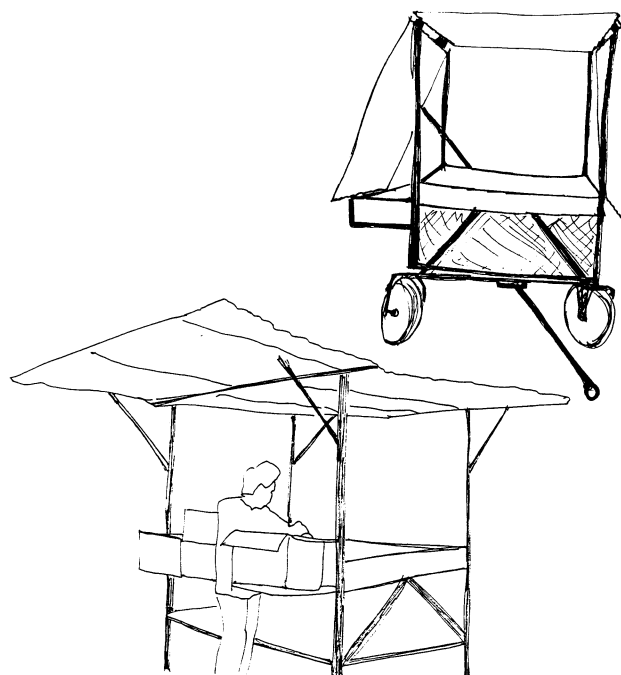

A self-propelled field pack system allows field workers to cut, trim, tie/wrap and pack *in the field*, thus eliminating the expense of operating a packing shed. In the illustration below, a fiat bed truck is moving alongside the field pack system, and packed produce is being loaded for transport.

### Self-Propelled Field Pack System

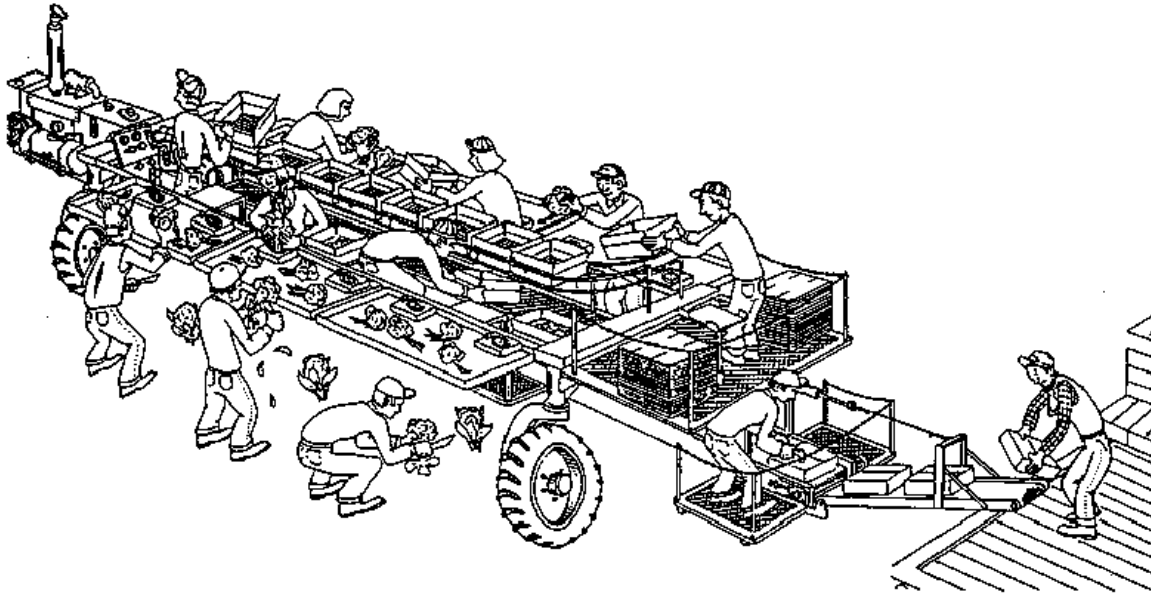

Options:

- Number of worker positions per side
- Row spacing
- Ground clearance
- Can harvest front, rear, or both

Source: Highlander Ramsay Welding Machine Promotional Brochure. 1993.

## Transport to the Packinghouse

When crops are harvested at some distance from the packinghouse, the produce must be transported before packing. The gravity-driven conveyor system for bananas illustrated below provides an example of how handling can be minimized during preparation for market. Harvested bananas are carried to the platforms set up along the conveyor route, then lifted and hung from hooks attached to the wire. Transport speed is controlled by workers who lead the produce to the packinghouse at the bottom of the hill.

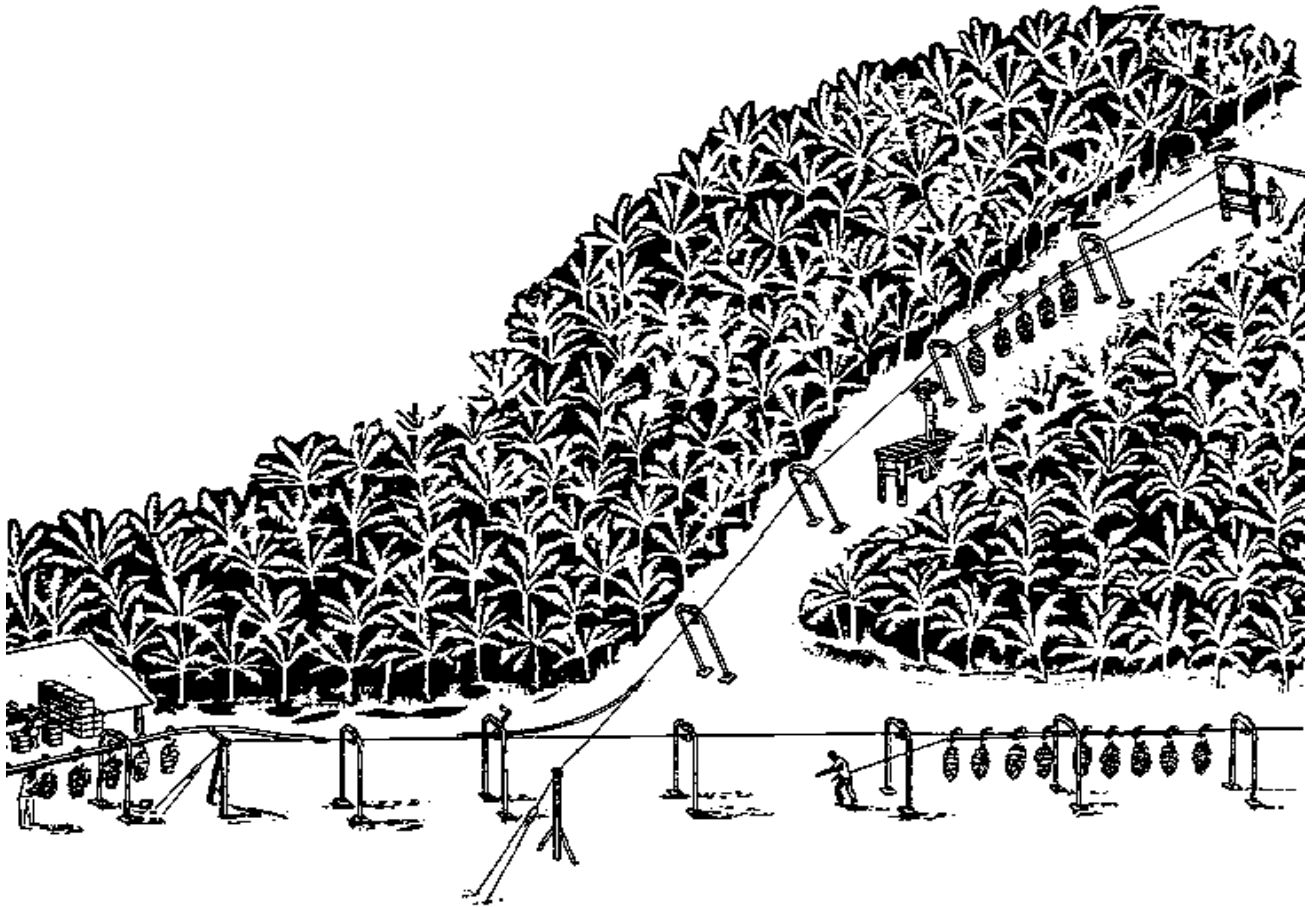

Source: NIAE. 1977. Banana Conveyor. Tropical Agricultural Engineering Information O.D. Bulletin No. 7. National Institute of Agricultural Engineering, Silsoe, Bedfordshire, England. p.1

## **Chapter 2: Curing Root, Tuber and Bulb Crops**

Curing root and tuber crops, such as sweet potatoes, potatoes, cassava and yams, is an important practice if these crops are to be stored for any length of time. Curing is accomplished by holding the produce at high temperature and high relative humidity for several days while harvesting wounds heal and a new, protective layer of cells form. While curing can be initially costly if it is necessary to use added heat, the long extension of storage life makes the practice economically worthwhile.

The best conditions for curing vary among crops as shown in the following table:

| Commodity          | Temperature |        | Relative Humidity<br>(%) | Days |
|--------------------|-------------|--------|--------------------------|------|
|                    | °C          | °F     |                          |      |
| Potato             | 15-20       | 59-68  | 90-95                    | 5-10 |
| Sweet potato       | 30-32       | 86-90  | 85-90                    | 4-7  |
| Yarns              | 32-40       | 90-104 | 90-100                   | 1-4  |
| Cassava (Manioc)   | 30-40       | 86-104 | 90-95                    | 2-5  |
| Cocoyams (Malanga) | 30-35       | 86-95  | 95                       | 3-5  |

Curing, when used for onions, garlic and flowering bulbs, refers to the practice directly following harvest. It allows the external layers of skin and neck tissue to dry out prior to handling and storage. If local weather conditions permit, these crops can be under-cut in the field, windrowed and left for five to ten days to dry naturally. The dried tops of the plants can be arranged to cover and shade the bulbs during the curing process, protecting the produce from excess heat and sunburn. If forced, heated air is used for curing onions and other bulbs, one day or less at 35 to 45 °C (95 to 113 °F) and 60 to 75% relative humidity is recommended. The dried layers of “skin” then protect the produce from further water loss during storage.

## Field Curing

Yams and other tropical root and tuber crops can be cured outdoors if piled in a partially shaded area. Cut grasses or straw can be used as insulating materials and the pile should be covered with canvas, burlap or woven grass mats. Curing requires high temperature and high relative humidity, and this covering will trap self-generated heat and moisture. Never use plastic covers, as the pile can then become too hot, which will harm the produce. The stack should be left for about four days (yams) or five days (cassava, sweet potatoes, or cocoyams) and then checked to feel the peel of the produce. If the peel is firmly attached and does not slip when pressed sideways using light finger pressure, the curing process is complete.

### Cut-away View of Yam Curing

Cut-away view of yam curing

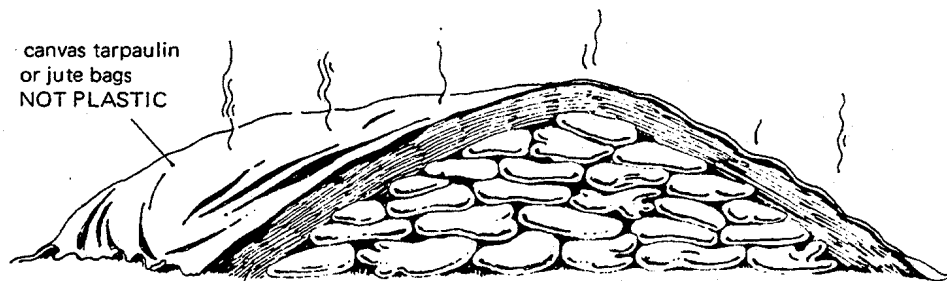

At least 6" (15 cm) depth of cut grass placed on top of yams.

Source: Wilson, J. (n.d.). Careful Storage of Yams: Some Basic Principles to Reduce Losses. London: Commonwealth Secretariat/International Institute of Tropical Agriculture. (IITA, Ibadan, Nigeria.).



Onions and garlics can be cured in the field in regions where the harvest coincides with the dry season. The crops can be cured either in windrows or after packing into large, woven, fiber or net sacks. The sacks must not be stacked, but placed in a way to leave plenty of open space to allow for excellent air flow. The produce can be left in the field for five days then checked daily until the outer skin and neck tissues are properly dried. Curing may take up to ten days, depending on weather conditions. It is important to check on the curing process each day.

Curing can be assisted by the use of ventilated sheds in regions where solar radiation and/or relative humidity is high or natural air movement is low. Produce in sacks can be stacked 2 or 3 high, in the shade on canvas tarpaulins, or in an open-sided shed under one or more ceiling fans. An exhaust vent in the roof can assist with air circulation.

#### **Curing Assisted by Shade and Ventilation:**

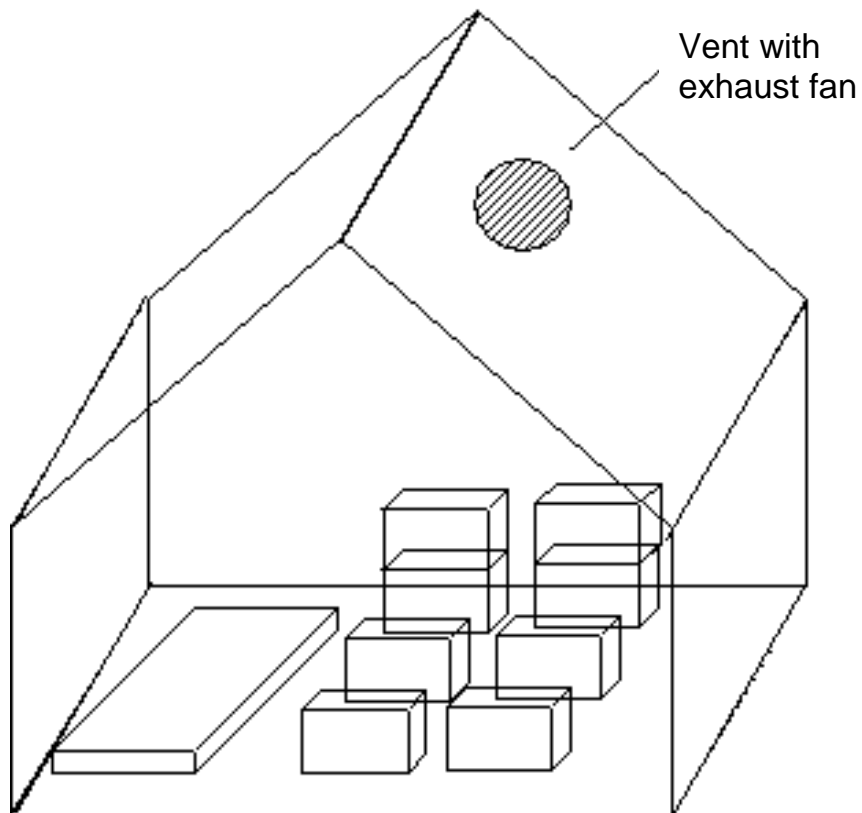

## Curing with Heated Air

The most uniform distribution of heat is obtained when heat is introduced near the floor level of a curing structure. Heaters can be placed on the floor near the bins of produce, or heat can be ducted in from outside the curing room. A high relative humidity can be obtained by wetting the floor or by using an evaporative cooler in the room without introducing outside air.

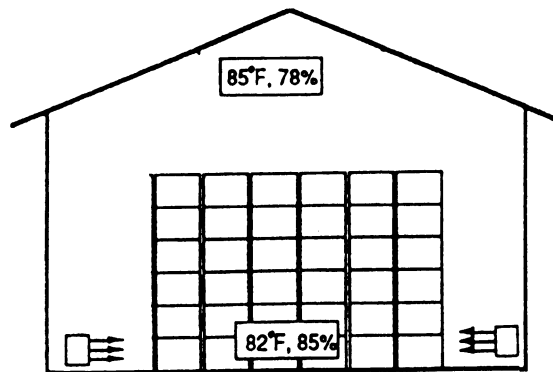

If heaters are located near the ceiling, then ceiling fans can be used to help redistribute the heat down into the room of produce. Bulk bins must be stacked to allow a gap of 10 to 15 cm. (4 to 6 inches) between rows for adequate air circulation.

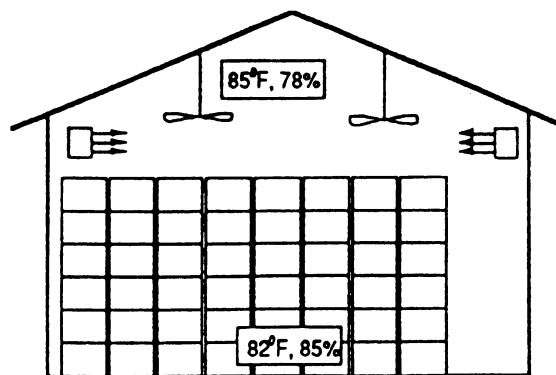

Source: Thompson, J. and Scheuerman, R.W. 1993. Curing and Storing California Sweet potatoes. Merced County Cooperative Extension. Merced, California.

## Bulk Systems for Curing Onions

Curing using a bulk system requires a fan, a heating unit and a slatted floor. The illustrations below show how air can be brought in, heated, and distributed through bulk onions in the curing room. An exhaust opening near the ceiling re-circulates heated air.

When using heated air it is easy to over-dry the bulbs, leading to a loss of external scales and exposure of the fleshy scales underneath. Curing onions should be checked regularly to avoid over-drying.

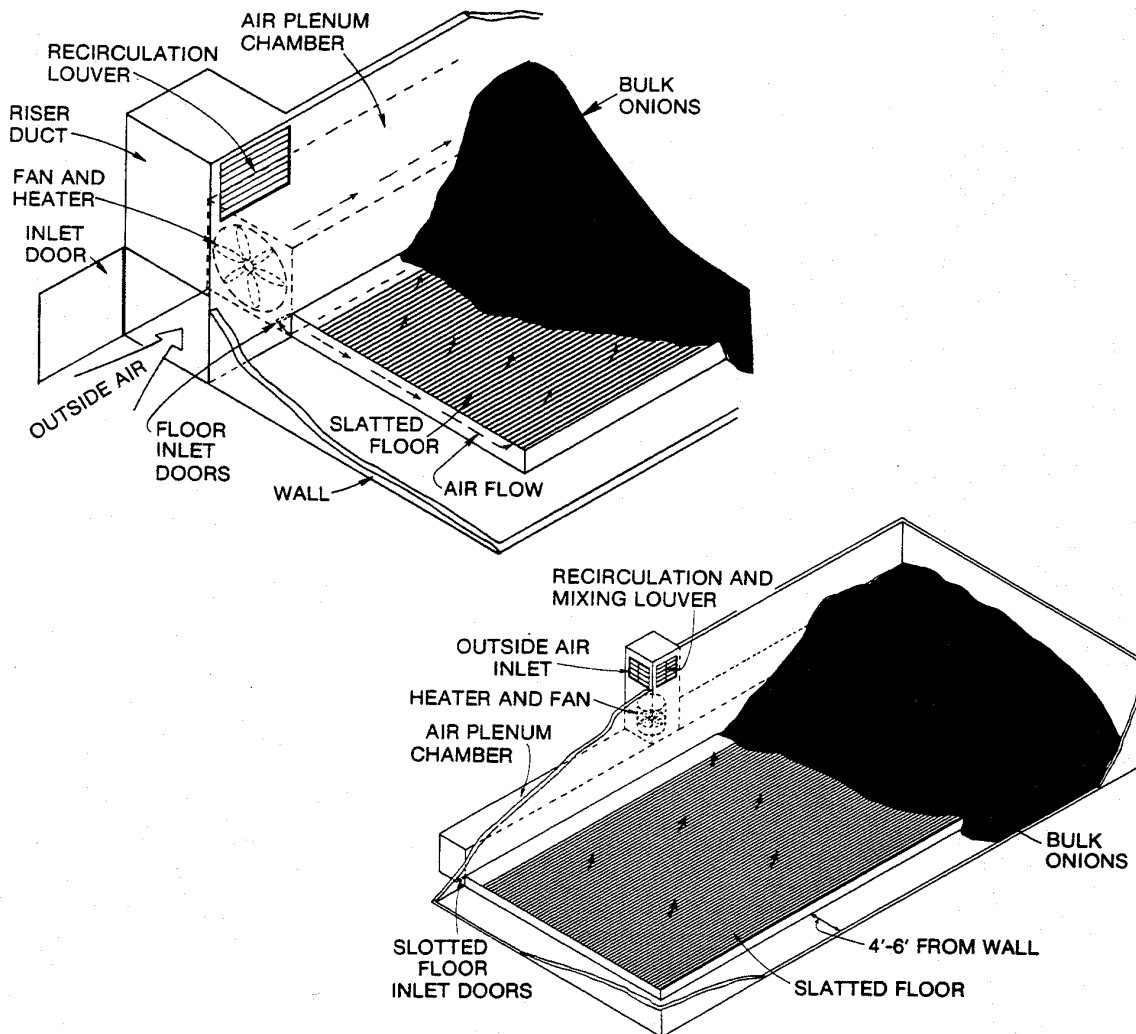

Source: Davis, H.R. et al. (n.d.). Storage Recommendations for Northern Grown Onions. Information Bulletin 148. Ithaca, NY: Cornell University Extension.

## Emergency Curing

If conditions, such as rain or flooded fields, do not permit field curing and curing facilities are not available, a temporary tent can be used for curing onions. In the example illustrated below, the tent is constructed from large tarpaulins. Heated air is forced into a hollow area (known as a plenum) at the center of the bins of produce. Several fans are used to circulate the warm air through the onions while they are curing.

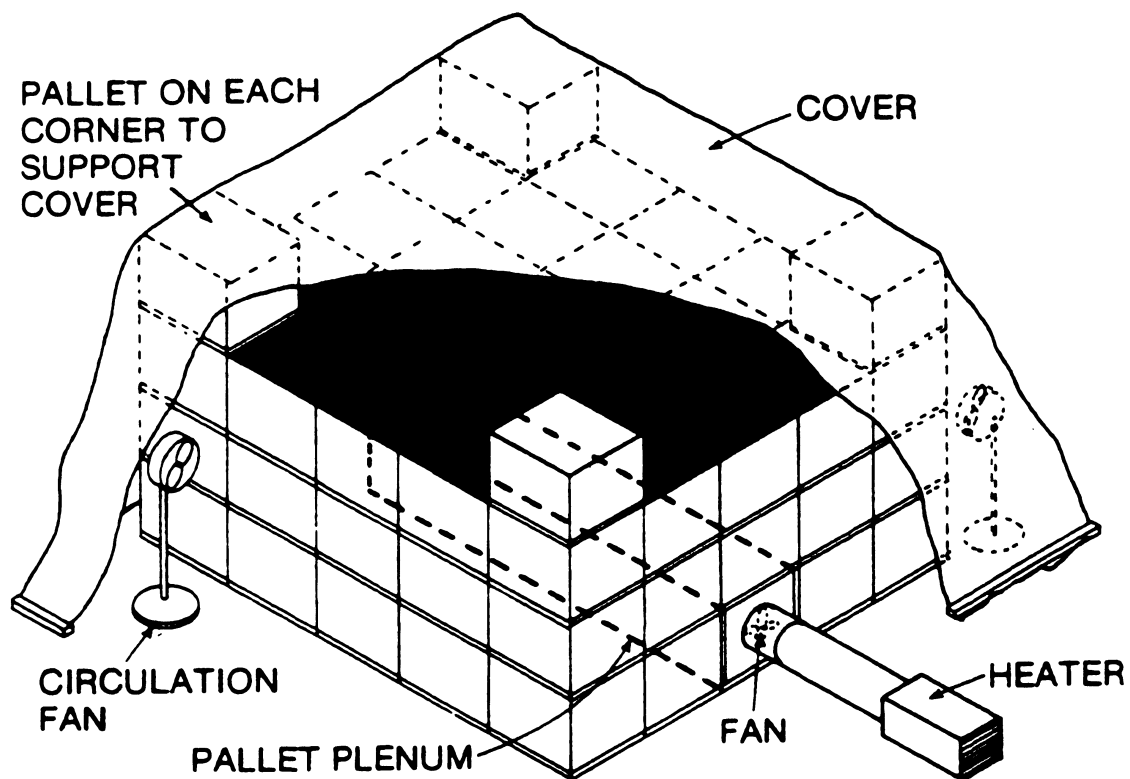

Source: Davis, H.R. et al. (n.d.). Storage Recommendations for Northern Grown Onions. Information Bulletin 148, Ithaca, New York Cornell University Extension.

## **Chapter 3: Packinghouse Operations**

---

Packinghouse operations can be as simple as moving produce from a field lug into a shipping container or may include a variety of handling practices, from cleaning, waxing, sizing, and quality grading to color sorting. The choice of operations will often depend upon the buyer's demands and on the market value of the produce.

The provision of shade during the packing operations is extremely important. Shade can be created using plant materials such as palm leaf fronds, a plastic mesh or canvas sheet hung from temporary poles, or via a permanent roofed structure.

When deciding upon where to locate a packinghouse, consider access to the field and market point, adequate space for vehicles to enter and leave the packinghouse, and ease of access to labor (Proctor, 1985).

In the simplest packinghouse, produce is delivered in picking containers (field lugs, buckets, or plastic crates) immediately after harvest and directly to the packers. The packers then sort, grade, size, and pack the produce directly into appropriate transport containers. In this case, each worker must be knowledgeable of produce defects, grade and size requirements, and packing methods.

As the size and complexity of the packinghouse increases, more operations and workers trained in specific tasks might be added.

### *Dumping*

Produce must somehow be removed from the field bin or harvesting container and moved through the packinghouse. This first step is known as "dumping." Dumping must be done gently, whether using water assisted methods or dry dumping. Wet dumping can decrease bruising and abrasions by using moving, chlorinated (100-150 ppm) water to carry delicate produce. When using dry dumping, padded, sloped ramps or moving conveyor belts can decrease injuries to produce.

### *Pre-sorting*

Pre-sorting produce is usually done to eliminate injured, decayed, or otherwise defective produce (culls) before cooling or additional handling. Pre-sorting will save energy such that culls will not be handled, cooled or packed. Removing decaying produce items will limit the spread of infection to other units, especially if postharvest pesticides are not being used.

### *Cleaning*

For some commodities, such as kiwifruits and avocados, dry brushing may be sufficient to clean the produce. Other commodities, however, such as bananas, potatoes, and carrots, require washing. The choice of brushing and/or washing will depend upon both the type of commodity and the type of contamination.

**Wash before cooling and packing:** tomatoes, cucumbers, leafy greens

**Wash** to remove latex, reduce staining: mangoes, bananas

**Wash after storage:** sweet potatoes, potatoes, carrots

**Dry brush** after curing or storage: onions, garlic, kiwifruit

**Do not wash:** green beans, melons, cabbage, okra, peas, peppers, summer squash

Sanitation is essential, both to control the spread of disease from one item to another and to limit spore buildup in wash water or in the packinghouse air. Chlorine treatments (100 to 150 ppm Cl) can be used in wash water to help control pathogen buildup during packing operations (Moline, 1984; Ritenour et al., 2014). There is some variation in the strength of bleach available commercially in different countries, but a rule of thumb is to use 1 to 2 mLs of chlorine bleach per liter (1 to 2 ounces of chlorine bleach per 8 gallons of clean water). **Food safe** chlorine products must be used, since those intended for washing clothing may have added ingredients.

In the USA, the crop name must be on the label (EPA FIFRA regulations) and the product must be registered for use in your state. Examples of registered products are ultra-Clorox brand bleach, Decco AgClor 310, and Pioneer Ag Sanitizer 12.5%.

Walls, floors, and packing equipment can also be cleaned using quaternary ammonium compounds labeled as safe for food processing equipment (Kupferman, 1990).

### *Waxing*

Waxing of immature fruit vegetables, such as cucumbers and summer squash; mature fruit vegetables, such as eggplant, peppers, and tomatoes; and fruits, such as apples and peaches, are common. **Food grade waxes** are used to replace some of the natural waxes removed in washing and cleaning operations, and can help reduce water loss during handling and marketing. If produce is waxed, the wax coating must be allowed to dry thoroughly before further handling.

### *Sizing*

Sizing produce is optional but may be worthwhile if certain size grades receive a higher price than others. In most low-input packinghouses, manual sizing is still commonly practiced. Operators should be trained in selecting the size that is desired and to either directly pack the items into containers or place the selected produce gently into a bin for packing farther down the line. Sizing can be done subjectively (visually) with the use of standard size gauges. Examples of the smallest and largest acceptable sizes for each product can be placed within view of the operator for easy reference. Handheld sizers are used for a variety of products.

Many products have established U.S. grades and standards that can assist packers in sorting and sizing produce. The following are examples of standards based upon diameter and/or length.

Examples of USDA Grade Standards:

| Rhubarb Grades | Diameter   | Length      |
|----------------|------------|-------------|
| U.S. Fancy     | > 1 inch   | > 10 inches |
| U.S. No.1      | > 3/4 inch | > 10 inches |
| U.S. No.2      | > 1/2 inch | > 10 inches |

| Garlic size designations | Diameter in inches |
|--------------------------|--------------------|
| #11 Super-Colossal       | 2 15/16 and up     |
| #10 Colossal             | 2 11/16 – 2 15/16  |
| #9 Super-Jumbo           | 2 7/16 – 2 11/16   |
| #8 Extra-Jumbo           | 2 3/16 – 2 7/16    |
| #7 Jumbo                 | 1 15/16 – 2 3/16   |
| #6 Giant                 | 1 13/16 – 1 15/16  |
| #5 Tube                  | 1 11/16 – 1 12/16  |
| #4 Medium Tube           | 1 9/16 – 1 11/16   |

Several types of mechanical sizers are available for small scale operations. One type is composed of a long slanted tray with a series of openings which converge (largest at the top, smallest at the bottom). This type of sizer works best with round commodities. Other sizers are designed as conveyors fitted with chain or plastic belts with various sized openings, and are useful for sizing most commodities. Another simple method for mechanical sizing is to use a set of diverging bar rollers (see illustration below), where the smallest sized produce falls through the rollers first to a sorting belt or bin, and larger sized produce falls between successively more divergent rollers.

#### Diverging Bar Rollers Sizer:

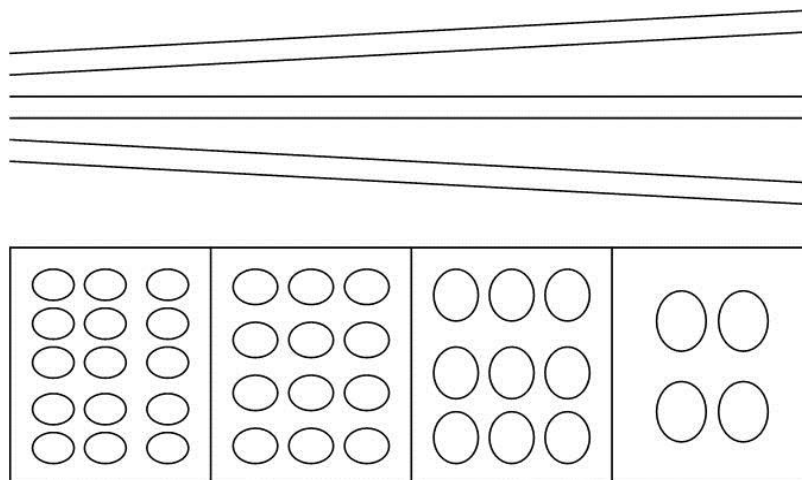

## Best Practices for Packinghouse Operations

| <b>DO</b>   | <b>DO NOT</b>   |
|---|---|
| Provide shade for harvested produce waiting to be sorted and packed.  | Locate the packinghouse directly next to an unpaved, dusty road.  |
| Grade the roads and entryways between the field and the packing facility to make the road surfaces smooth.                                      | Wash green beans, cabbage, okra, peas, peppers, or summer squash before packing.                          |
| Minimize mechanical damage--avoid drops, throwing, and rough handling.  | Remove more than necessary of the produce when trimming for quality. Dispose of waste materials properly. |
| Use hand-carts to assist workers in the careful movement of produce.  | Overfill or under-fill packages. Pack securely to immobilize produce.                                     |
| Pre-sort to remove damaged, diseased, and immature or over-mature produce.  | Use any chemical treatments that are not specifically recommended or approved for your commodity.         |
| Keep the packing line and facility clean.   |   |
| Keep the packing line as simple as possible, and as straight as possible (avoid turns).   |   |
| Provide cushioning on all sharp edges and rough surfaces of packing tables or the washing/sorting/grading/packing line.                         |   |
| Use appropriate postharvest treatments (waxing, hot water dips, SO <sub>2</sub> , fungicides, etc.) to reduce the rate of decay and water loss. |   |
| Cool the produce as soon as possible after harvesting and/or packing.   |   |



## Narrow Pallet System

The University of Wisconsin is promoting this handling system for produce because it saves time and money and is safer for handlers. With a hand pallet truck you can move up to 16 full cartons or plastic crates at a time. This system can cut the time spent moving boxes by hand and will dramatically reduce the stress on the worker's body.

A hand pallet truck is similar to a regular hand truck (dolly) except that the base uses pivoting forks instead of a fixed plate metal shoe. If you stack the load on a small plastic pallet (14 x 24 inches), you can position the forks underneath and move an entire stack of cartons at once. A hand pallet truck can be tilted (by releasing the forks) for loading and unloading and locked into an upright position to tip back and roll the load.

According to the UWisconsin project, custom-made hand pallet truck and pallet costs approximately \$750. At \$7.00 per hour, you'd need to save 107 hours for the system to pay for itself. If you saved 30 minutes per weekday (10 hours per month), the system would pay for itself in less than 11 months.



Source: December, 2000. Work Efficiency Tip Sheet: Narrow Pallet System. Second Edition. University of Wisconsin Healthy Farmers Healthy Profits Project.

Custom hand trucks available from: Valley Craft, 2001 South Highway 61, Lake City, MN 55041. (800) 328-1480. carts@valleycraft.com.

## General Operations

The typical series of operations in a packinghouse are illustrated below. Dumping can be done using either dry or water-assisted methods, depending upon the sort of produce being handled. Cleaning, as well, can be done by washing with chlorinated water or dry brushing alone. Waxing, if practiced, occurs after washing and removal of surface moisture. Grading, as illustrated, separates the product into processing and fresh market categories. Sizing further separates the product, with the smallest size going to the local market or to processing. Typically, the best quality produce is packaged and marketed at the regional or national level.

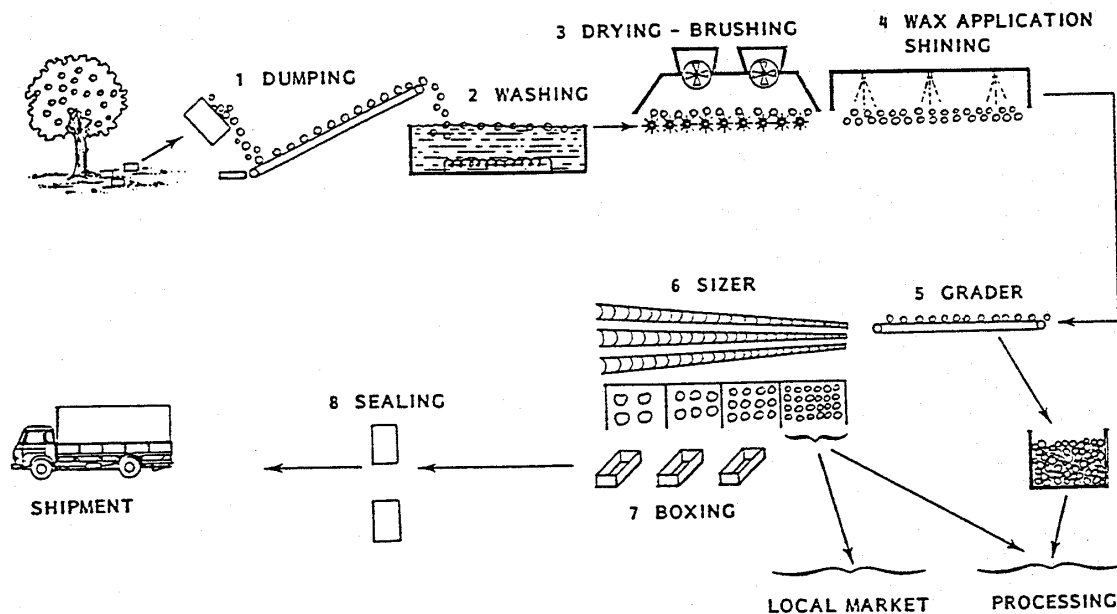

Source: FAO. 1986. Improvement of Post-Harvest Fresh Fruits and Vegetables Handling - A Manual. Bangkok: UNFAO Regional Office for Asia and the Pacific.

## Packinghouse Layout

Packing operations that are done in an unsystematic manner can cause delays, add costs, or affect produce quality. You can save time and money by laying out the packing shed in an organized, step-by-step system. The produce should move in one direction (in a straight line or in a U-shaped pattern), and you should avoid crossing paths when moving to different operations.

### Inefficient Design

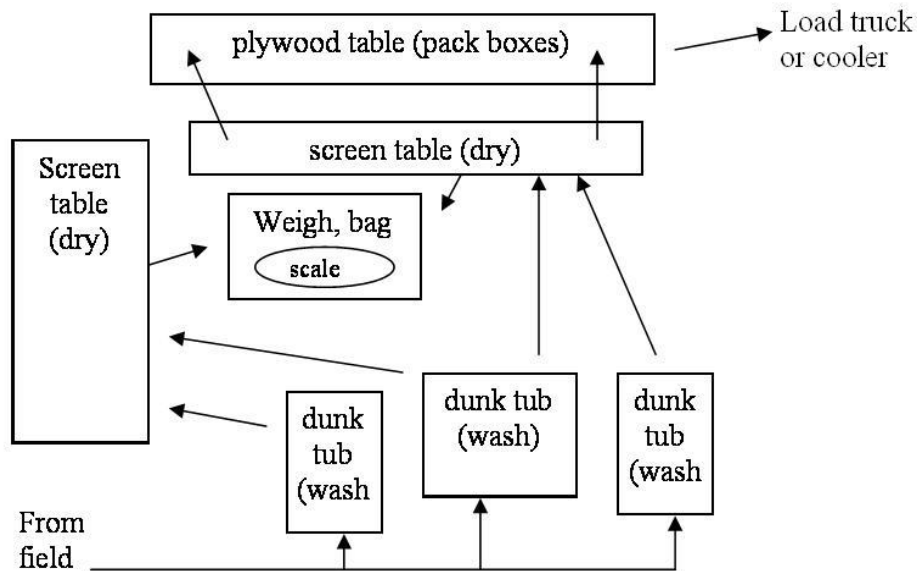

### U-shaped Design

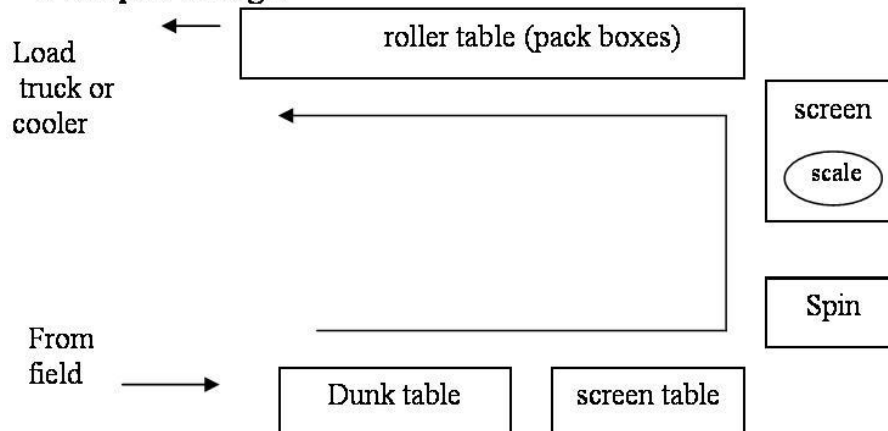

Source: Meyer et al. 1999. Work Efficiency Tip Sheet: Packing Shed Layout. Healthy Farmers, Healthy Profits Project, Department of Biological Systems Engineering, College of Agricultural and Life Sciences, University of Wisconsin.

## Dumping

Any time produce is dumped from one container into another, care should be taken to reduce mechanical damage to the commodity. When dumping produce from field bins or from transport vehicles into the packinghouse, dry or wet dumping can be practiced. The pickers should be trained to minimize the drop height using smaller containers or special harvesting bags that have openings on the bottom. When using dry dumping practices, the field container should be emptied slowly and gently onto a tilted ramp with padded edges. In the illustration below, a conveyor belt then carries the dry-dumped produce into the packinghouse.

### Dry dumping

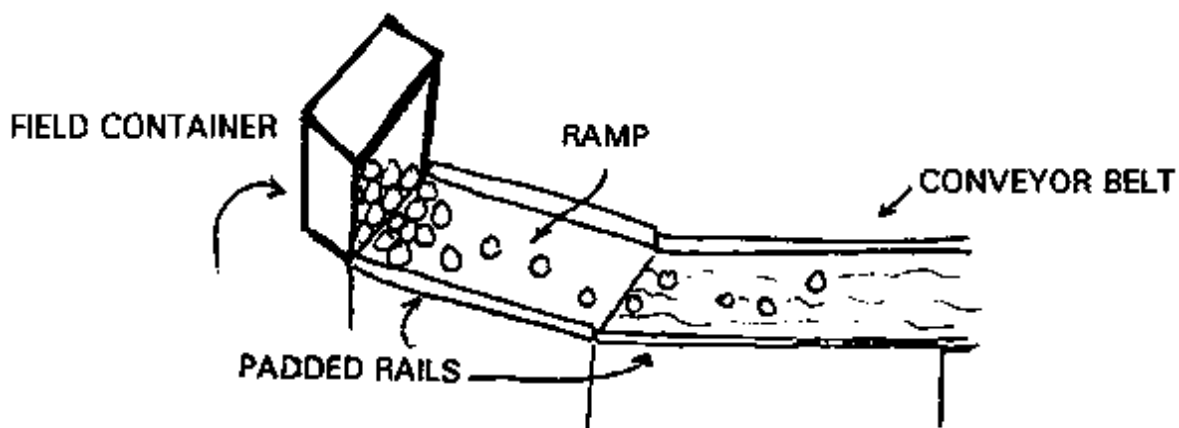

Wet dumping is sometimes used to reduce mechanical damage, either by dumping into water rather than onto a dry ramp, or by immersion and flotation. If the specific density of the produce, such as apples, is lower than that of water, the produce will float. For some produce, such as pears, salts, such as sodium lignin sulfonate, sodium silicate, or sodium sulfate, must be added to the water to increase its specific density and assure fruit flotation.

The canvas curtain illustrated below is used to break the fall of fruit moving from a conveyor into a bulk bin.

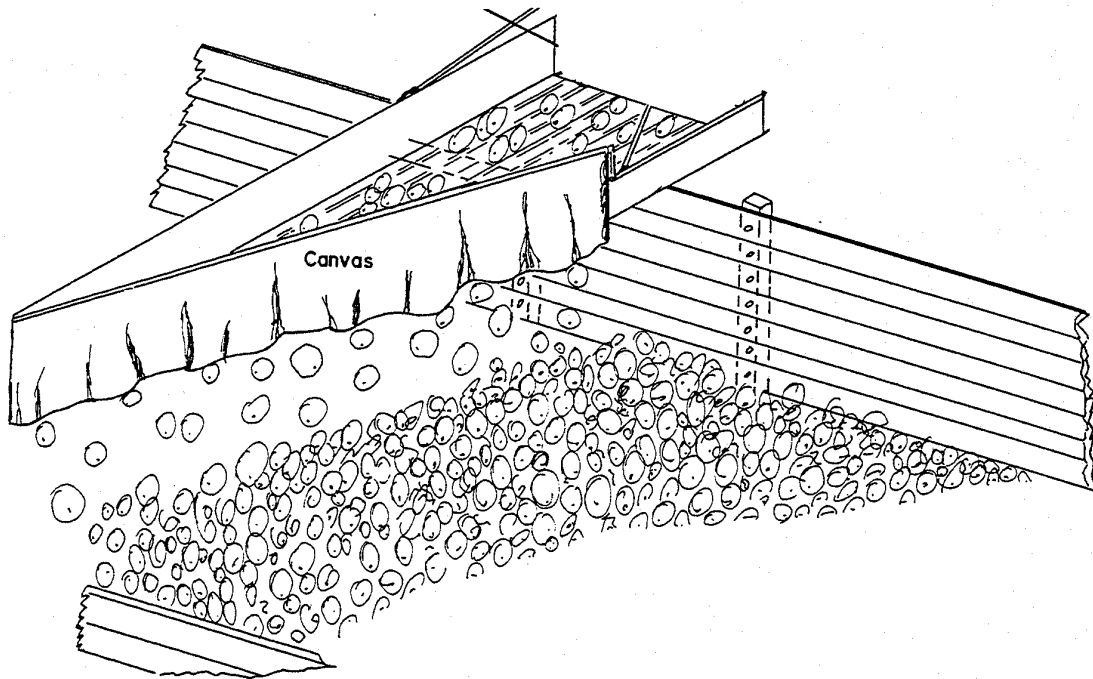

Source: USDA. (n.d.). Modernizing Handling Systems for Florida Citrus from Picking to Packing Line Agricultural Research Service. USDA Marketing Report No. 914.

## Conveyor Equipment

To reduce bruising:

- Use foam-padded ramps
- Slow produce speed on ramps by installing retarding flaps, curtains, blankets, or drapes
- Use a flexible drape to slow fruit as it falls from a higher conveyor belt to a lower one (use a lightweight drape for short transition, heavier drape for higher transition)
- Belt to prevent produce from falling directly onto roller sizes
- Remove support pan from under belt in an area where fruit lands on a new belt

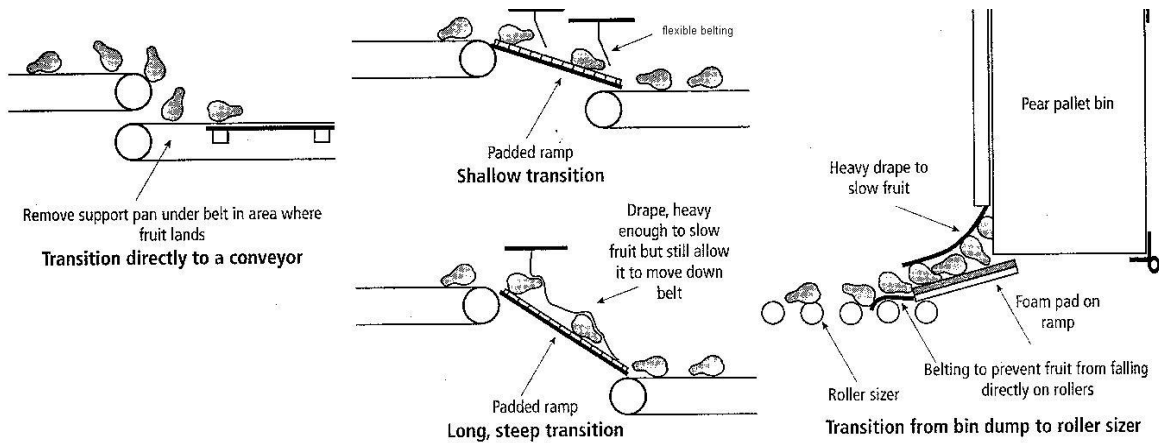

Source: Kader, A.A., (ed.). 2002. Preparation for Fresh Market Postharvest Technology of Horticultural Crops. University of California, Division of Agriculture and Natural Resources. Publication 3311. p. 67-79.

## Washing

Steel drums can be used to make a simple washing stand. The drums are cut in half, fitted with drain holes, and all the metal edges are covered with a split rubber or plastic hose. The drums are then set into a sloped wooden table. The table top is constructed from wooden slats or sheet metal and is used as a drying rack before packing.

Because steel drums are often used to store petroleum and chemical products, they should be thoroughly cleaned before being used as a washing stand. Special food safe paints should be used to prevent rusting of the steel drums.

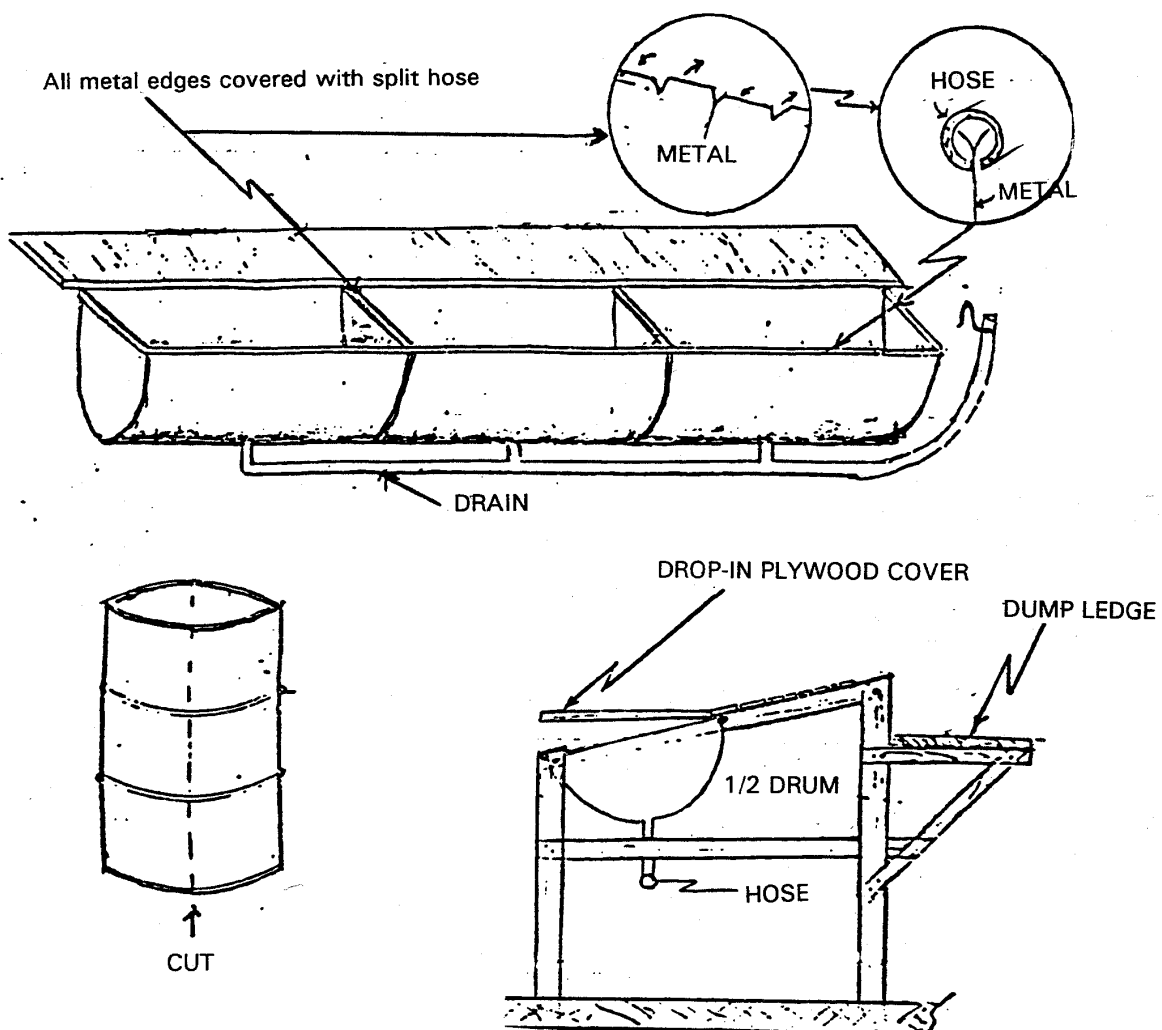

Source: Grierson, W. 1987. Postharvest Handling Manual. Commercialization of Alternative Crops Project. Belize Agribusiness Company/USAID/Chemonics International Consulting Division.

This tank for washing produce is made from galvanized sheet metal. A baffle made of perforated sheet metal is positioned near the drain pipe and helps to circulate water through the produce. Fresh water is added under pressure through a perforated pipe, which helps move floating produce toward the drain end of the tank for removal after cleaning.

Improvements to the design shown below might include a removable trash screen in front of the baffle, and/or a re-circulating system for the wash water (with the addition of chlorine).

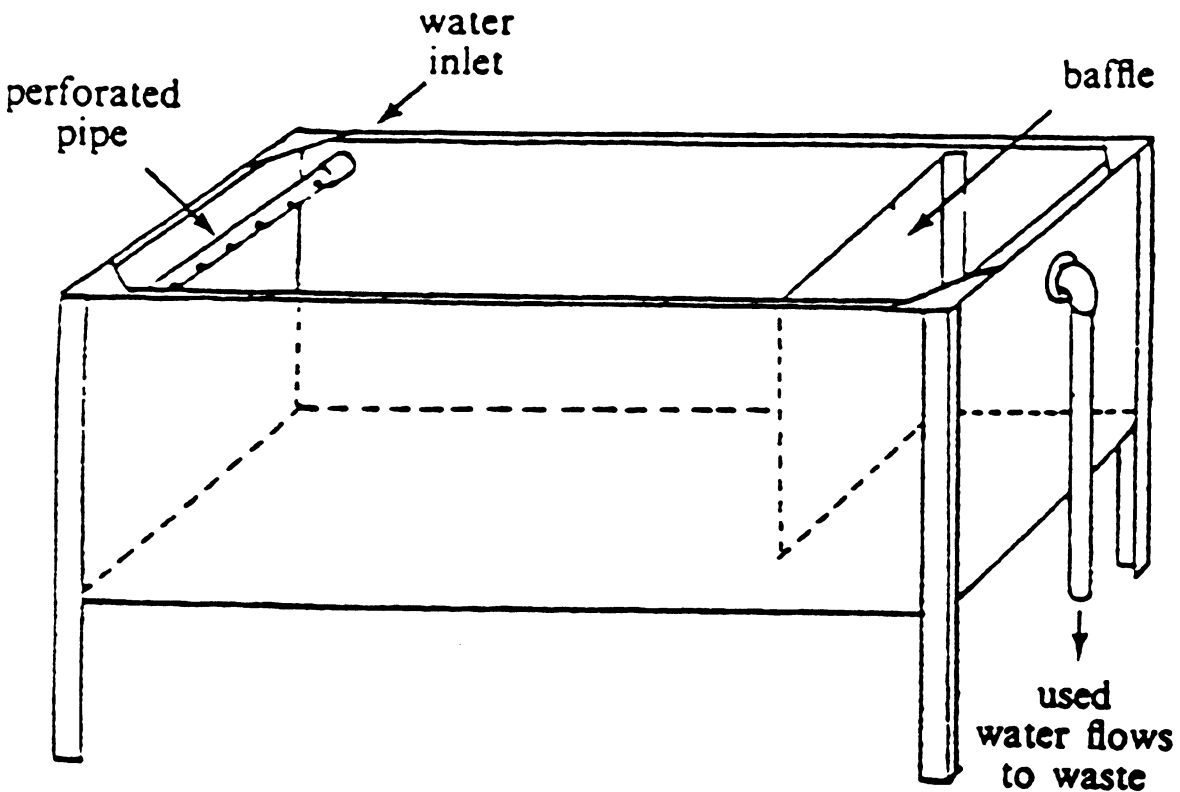

Source: FAO. 1989. Prevention of Postharvest Food Losses: Fruits Vegetables and Root Crops. A Training Manual. Rome: UNFAO. p. 157.



Chlorination of wash water is very important. Chlorine can reduce the spread of contamination from one item to another during the washing stage. The pH of the wash water should be maintained at 6.5 to 7.5 for best results.

Typically 1 to 2 mLs of chlorine bleach per liter of clean water will provide 100 to 150 ppm total Cl. More chlorine will be required if temperatures are high or if there is a lot of organic matter in the wash water.

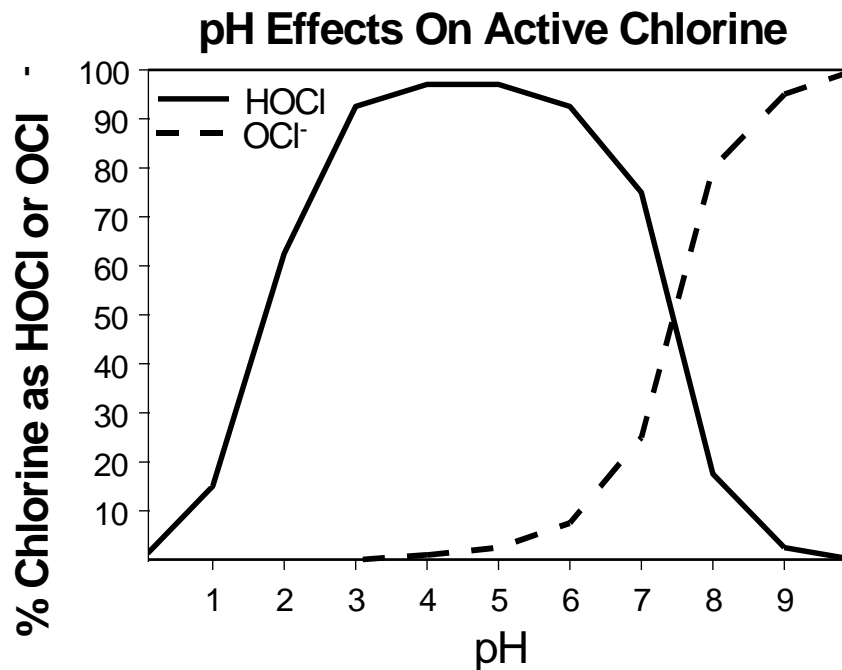

### Mixing chlorine solutions for washing fresh produce

| Desired ppm of free chlorine | mL of 5.25% NaOCl solution per 100 L of clean water | mL of 12.75% NaOCl solution per 100 L of clean water | grams of 65% Ca (OCl) <sub>2</sub> per 100 L of clean water |
|------------------------------|---|--|---|
| 100                          | 188   | 75   | 16  |
| 125                          | 234   | 100  | 20  |
| 150                          | 288   | 112  | 23  |
| 175                          | 338   | 138  | 27  |
| 200                          | 375   | 163  | 32  |

Source: Ritenour, M.A., Sargent, S.A., & Bartz, J.A. 2014. Chlorine Use In Produce Packing Lines. UF/IFAS HS-761. Retrieved from <https://edis.ifas.ufl.edu/ch160>  
(Modified from pints/gallons/ounces to liters/ml/grams)

## Waxing

The waxing device illustrated here is designed to be used after a series of dry brushes on a conveyor line. Industrial wool felt is used to distribute the liquid wax to the fruits or vegetables from a trough made with the same width as the belt. Evaporation of wax from the felt is reduced by covering the felt with a layer of heavy polyethylene sheeting.

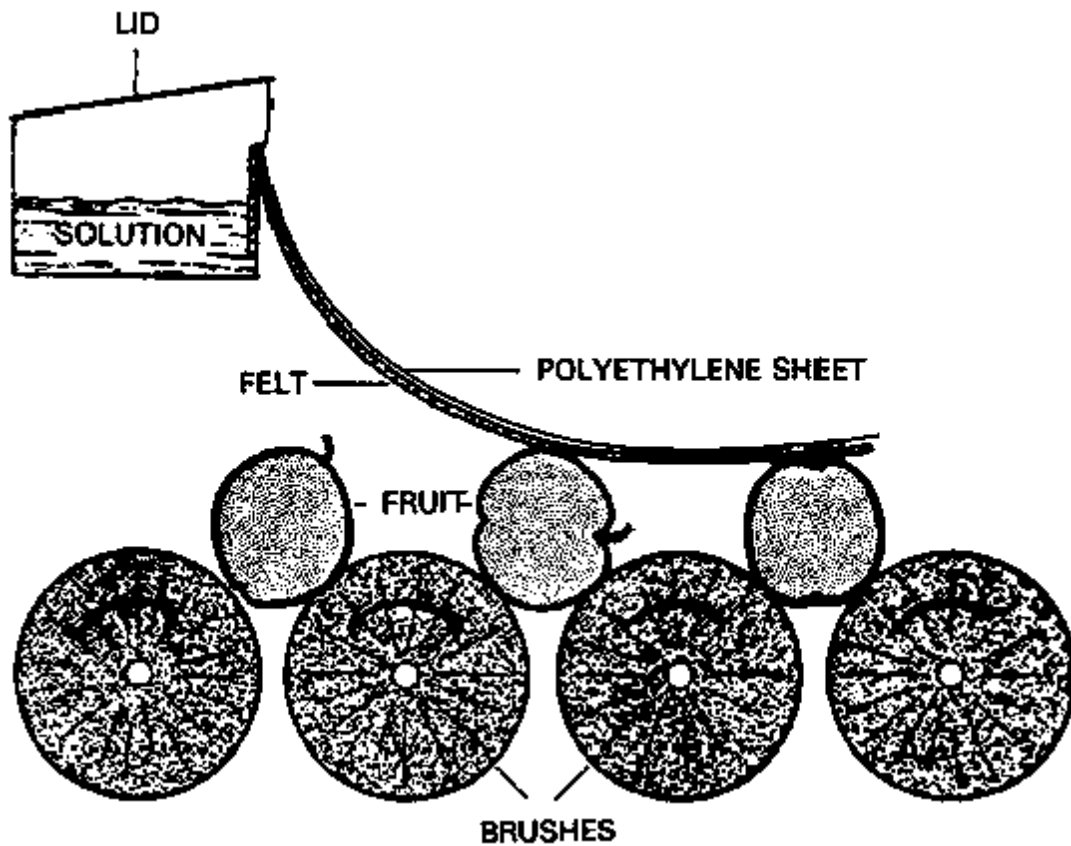

Source: Martin, D. and Mieztis, E.O. 1964. A wipe-on device for the application of materials to butts. Field Station Record Volume 3 No. 1. CSIRO Tasmanian Regional Laboratory, Hobart, Tasmania.

## Sorting

The table illustrated below is a combination sorting and packing stand. Incoming produce is placed in the fabric sorting bin, sorted by one worker into the packing bin, and finally packed by a second worker. If workers must stand to sort produce, a firm rubber pad for the floor can help to reduce fatigue.

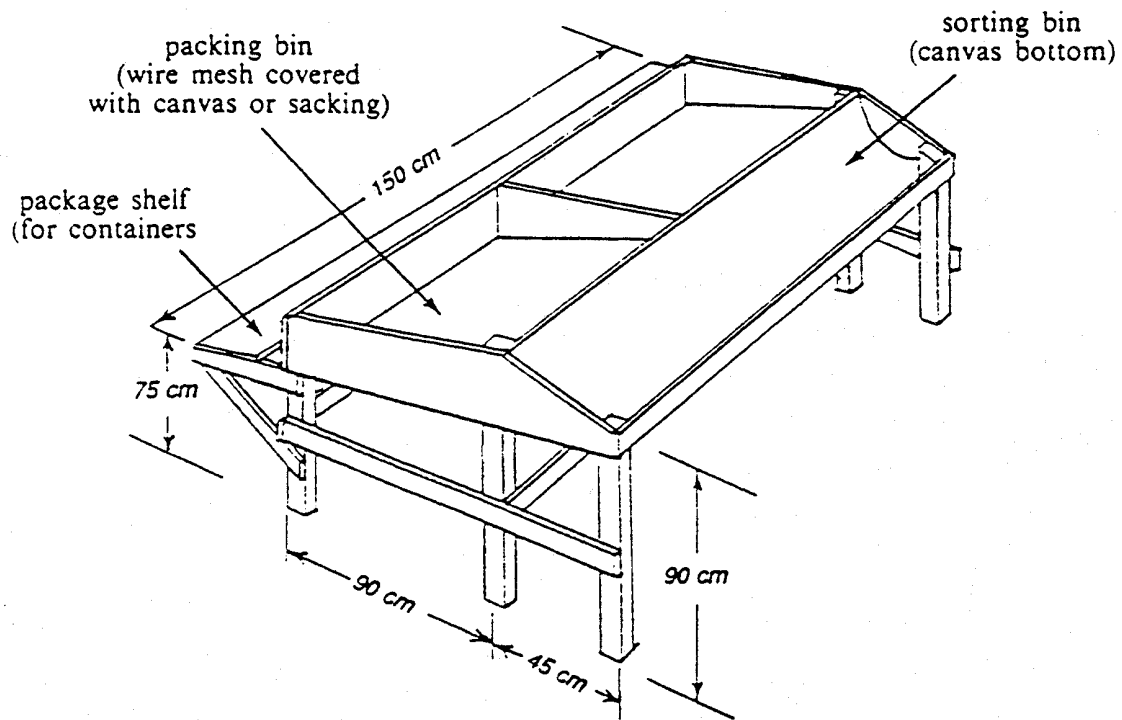

Source: FAO. 1986. Improvement of Post-Harvest Fresh Fruits and Vegetables Handling- A Manual. Bangkok: UNFAO Regional Office for Asia and the Pacific.

The surface of the portable sorting table illustrated below is constructed from canvas and has a radius of about 1 meter (about 3 feet). The edges are lined with a thin layer of foam to protect produce from bruising during sorting, and the slope from the center toward the sorter is set at 10 degrees. Produce can be dumped onto the table from a harvesting container, then sorted by size, color and/or grade, and packed directly into shipping containers. Up to 4 sorters/packers can work comfortably side by side.

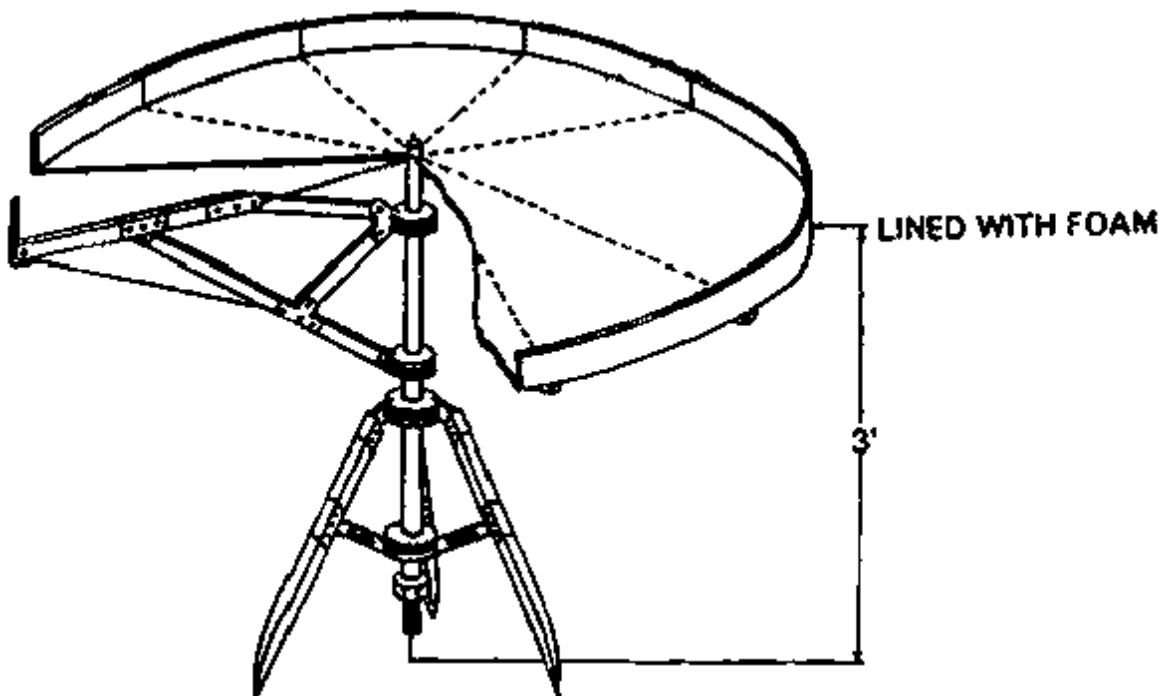

Source: PHTRC. 1984. A portable sorting table. *Appropriate Postharvest Technology* 1(1):1-3. Post-Harvest Training and Research Center, Department of Horticulture, University of the Philippines at Los Banos.

When sorting for rejects and removing any product that is too small, decayed or damaged, the height of the sorting table should be set at a level comfortable for sorters. Stools, or a firm rubber pad on which to stand, can be provided to reduce fatigue. Locations of the table and the sorting bins should be chosen to minimize hand movements.

It is recommended that the workers' arms create a 45 degree angle when s/he reaches toward the table, and that the width of the table be less than 0.5 meter to reduce stretching. Good lighting (500 to 1000 lux at work surface) will enhance the ability of the sorter to spot defects, and dark, dull belts or table tops can reduce eye strain. Anti-fatigue mats are essential where workers stand to help ease leg, foot, and lower back fatigue and pain. Using slip resistant, textured mats also reduces injuries.

If a conveyor system is in use, the product must not flow too fast for the sorters to work. The rotational speed of push-bar or roller conveyors should be adjusted to rotate the product twice within the immediate field of view of the worker. Periodical rotation of worker positions on the line will help to reduce monotony and fatigue. Supervisors should be able to quickly identify under-sorting and over-sorting.

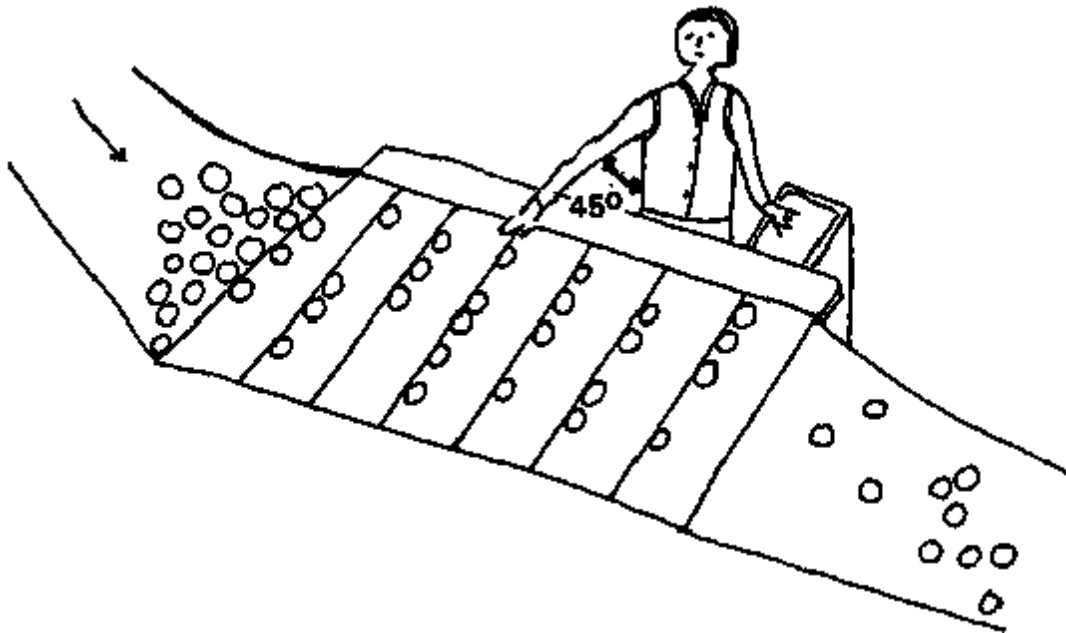

Source: Shewfelt, R.L. and Prussia, S.E. 1993. Postharvest Handling: A Systems Approach. San Diego: Academic Press Inc. p. 356.

The following illustration shows the key features of a well-designed sorting/grading station.

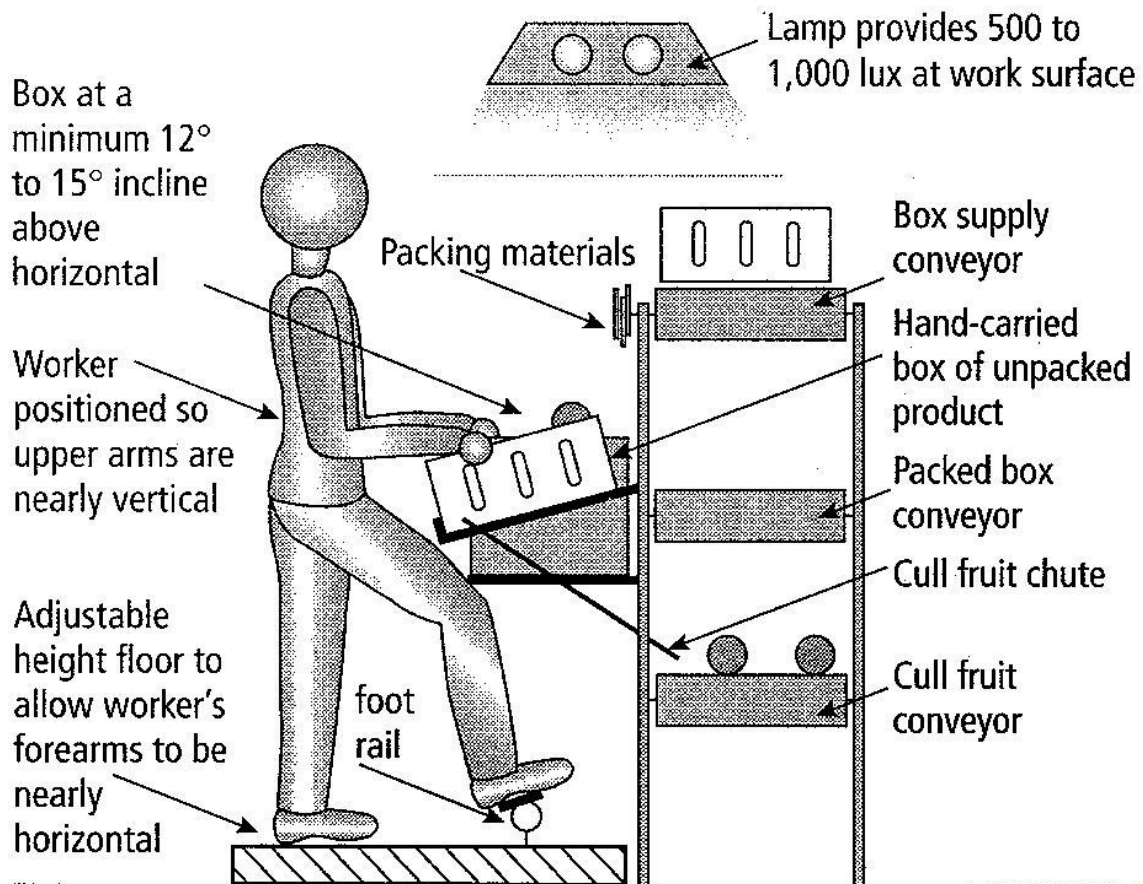

Source: Kader, A.A., ed. Thompson, J.F. et al. 2002. Preparation for Fresh Market Postharvest Technology of Horticultural Crops. University of California, Division of Agriculture and Natural Resources. Publication 3311. p. 67-79.

The following illustrations represent three types of conveyors used to aid sorting of produce. The simplest is a belt conveyor, where the sorter must lift and handle the produce manually in order to see all sides and inspect for damage. A push-bar conveyor causes the produce to rotate forward as it is pushed past the sorters. A roller conveyor rotates the product backwards as it moves past the sorter.

**Belt Conveyor:**



**Push-bar conveyor:**

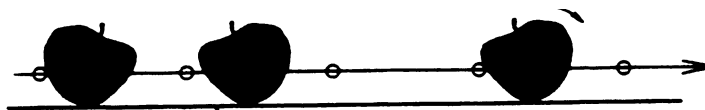

**Flat sorting surface**

**Roller conveyor:**

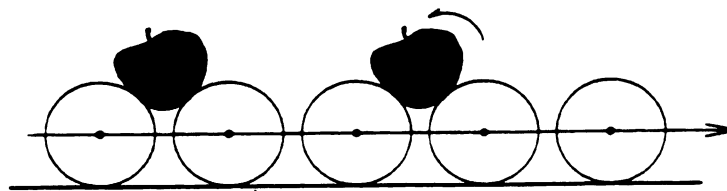

**Roller drive surface**

Source: Shewfelt, R.L. and Prussia, S.E. 1993. Postharvest Handling: A Systems Approach. San Diego: Academic Press Inc. p. 356.

## Sizing

Round produce units can be graded by using sizing rings. Rings can be fashioned from wood or purchased ready-made in a wide variety of sizes.

**Single-size handheld sizing ring:**

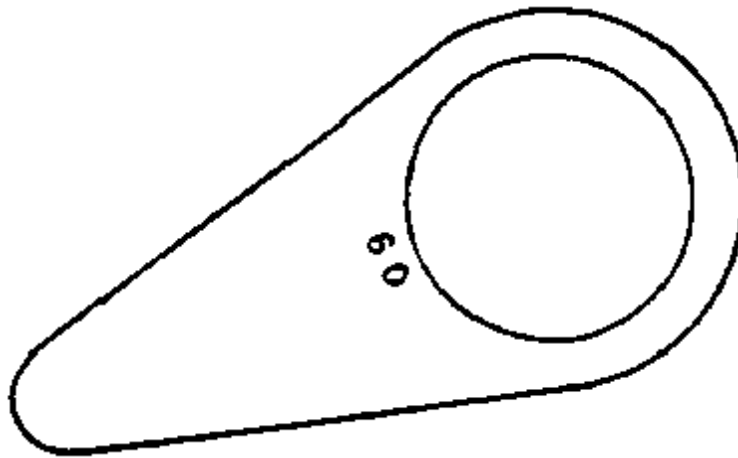

**Multiple-size rings:**

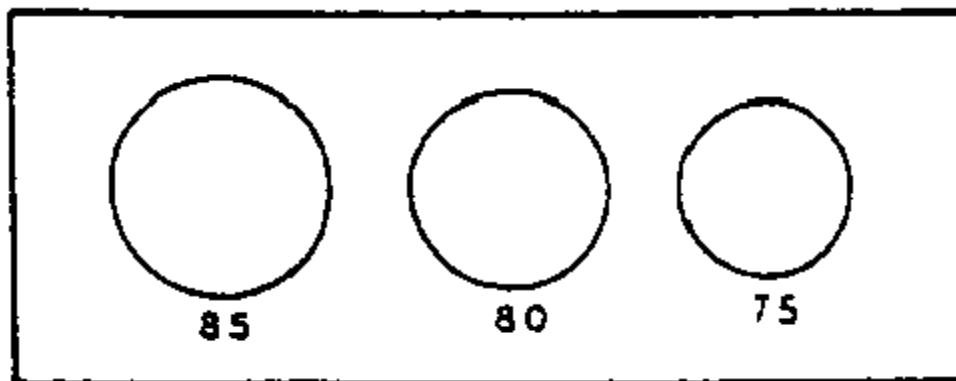

Source: FAO. 1989. Prevention of Postharvest Food Losses: Fruits, Vegetables and Root Crops. A Training Manual. Rome: UNFAO. p. 157.



USDA size grades for Bermuda-Granex-Grano type onions:

- Small: less than 57 mm in diameter
- Medium: 57 to 82 mm in diameter
- Large: minimum 76 mm in diameter
- Colossal: minimum 95 mm in diameter

Quality grades and size standards for many horticultural commodities can be found on the USDA website: <http://www.ams.usda.gov/AMSV1.0/standards>

Make your own sizing rings:

Medium gauge wire (10 g to 12 g copper solid core coated wire or aluminum wire) can be used to make sizing rings of any size needed for \$1.00 each or less in US Dollars. The strong wire can be cut to length and, using pliers and a round fixed object as a mold, twisted to make the shape shown below. This simple style sizing ring can be easily grasped with two fingers and used to assess the size of many types of produce. A small piece of PVC pipe or a soup can make inexpensive molds, and are readily available in 60 mm, 70 mm, 85 mm, and 100 mm outside diameter widths.

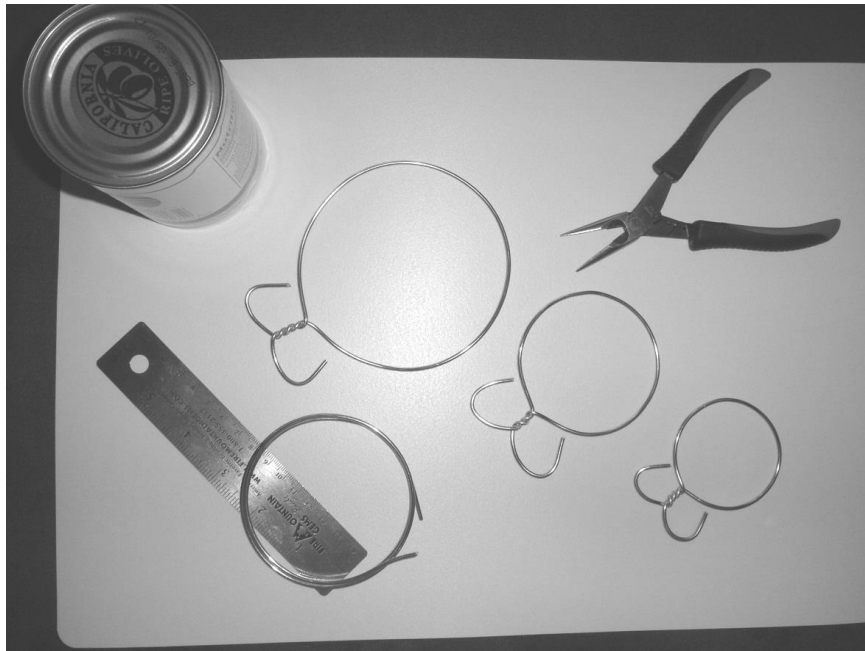

### Examples:

Small ring: use 12 inches (26.5 cm) of wire to make a ring 50 mm wide

Medium size ring: use 14 inches (33 cm) of wire to make a ring 70 mm wide

Large size ring: use 18 inches (43 cm) of wire to make a ring 100 mm wide

Source: 2012. Postharvest Innovations Plan Series Number 2.

The onion sizing table illustrated below is one of three (or more) tables used in a stairway or stepwise fashion. Each table is made of plywood, and has been perforated with holes of a specific size. The uppermost table has the largest size holes, and the lowest table has the smallest holes. A layer of onions is dumped onto the uppermost table. Those that do not pass through are classified as "extra-large" in size. Those that pass through the holes in the table fall into a mesh bag and roll into a large container. This container of onions is dumped onto the second sizing table. The onions that do not pass through are classified as "large", and so on.

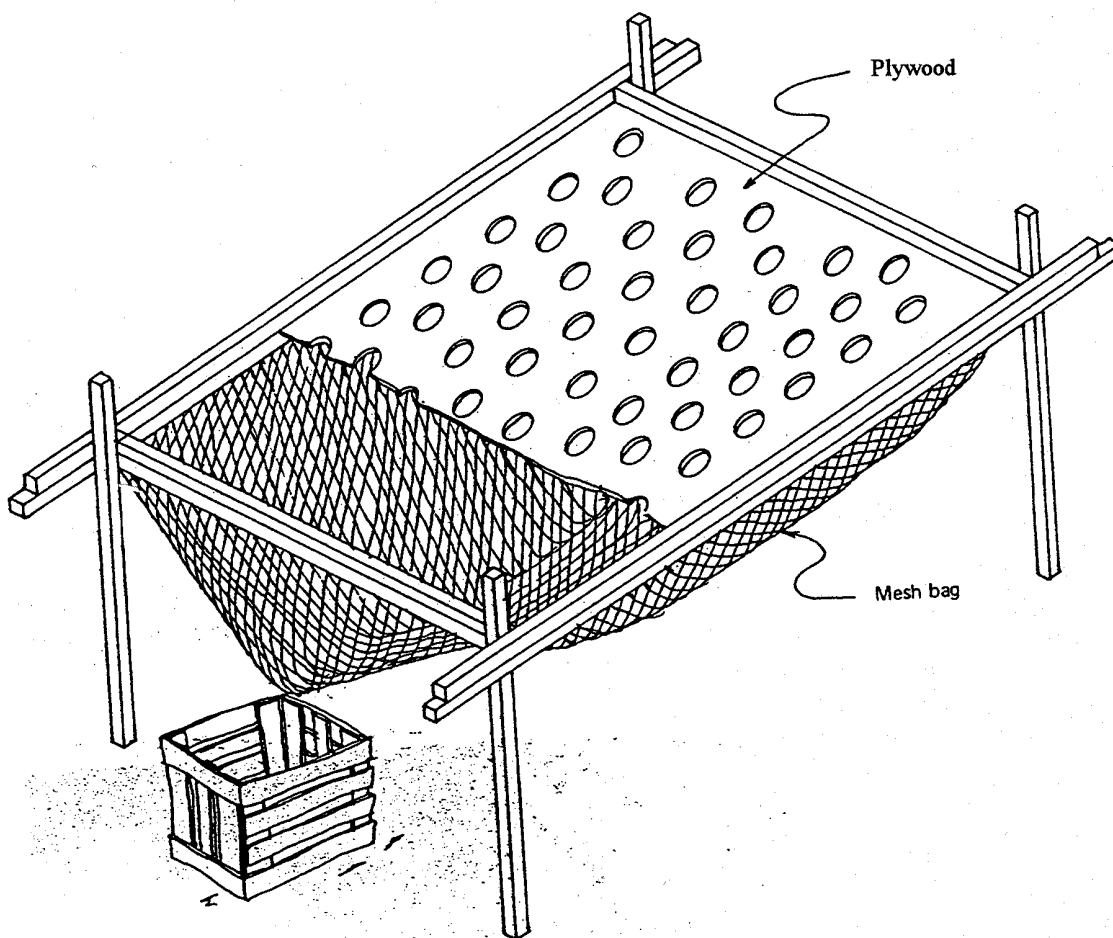

Source: Reyes, M. U. (ed.) 1988. Design Concept and Operation of ASEAN Packinghouse Equipment for Fruits and Vegetables. Postharvest Horticulture Training and Research Center, University of Los Baños, College of Agriculture, Laguna, Philippines.

The citrus fruit sizer illustrated below is composed of a rectangular chute made of plywood, padded with foam to prevent bruising. The fruit is dumped into the octagonal platform at the top of the chute, then allowed to roll, one by one, down toward a series of constrictions. Large fruits are caught in the first constriction, medium in the second, and small in the last. Undersized fruit passes out the end of the chute directly into a container. Workers must manually remove each fruit and place it into the appropriate size container before the next fruit can pass through the chute. The sizing is fastest when five workers are stationed at the sizer.

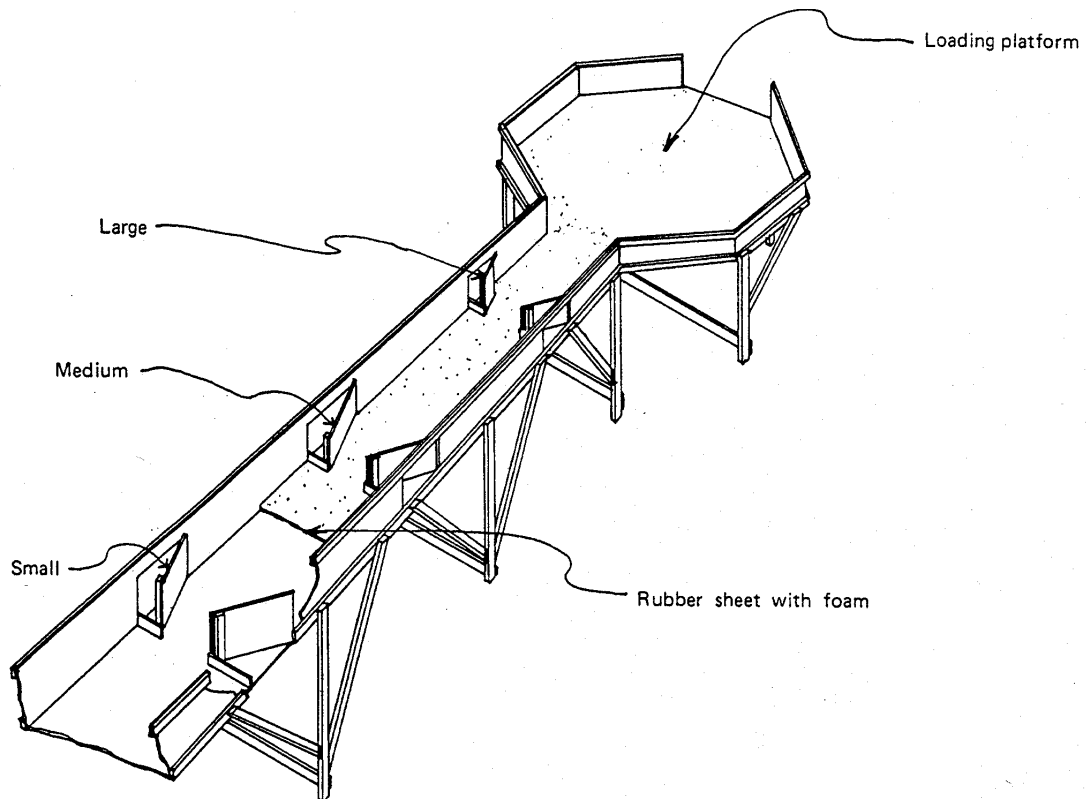

Source: Reyes, M. U. (ed.). 1988. Design Concept and Operation of ASEAN Packinghouse Equipment for Fruits and Vegetables. Postharvest Horticulture Training and Research Center, University of Los Baños, College of Agriculture, Laguna, Philippines.

If a conveyor system is used in the packinghouse, a wide variety of sizing chains and belts are available for sorting produce. Sizing chains can be purchased in many widths and in any size opening.

Square openings are usually used for commodities such as apples, tomatoes and onions, while rectangular openings are used for peaches and peppers. Hexagonal openings are often used for potatoes and onions.

**Square:**

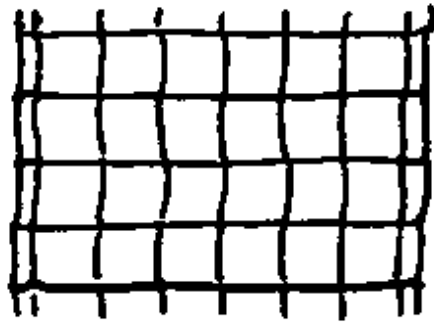

**Rectangular:**

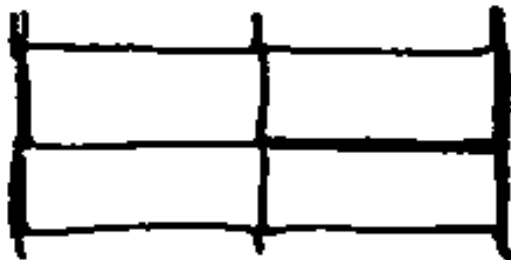

**Hexagonal:**

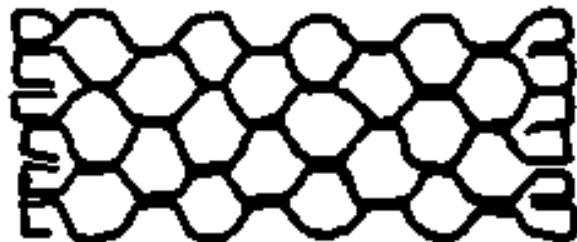

Source: 2001. Catalog of TEW Manufacturing Corporation, P.O. Box 87, Penfield, NY 14526 USA.

## Simple Packing Line

Small scale equipment for packing produce is available from several manufacturers and suppliers. Illustrated below is a fruit packing line available from TEW Manufacturing Corporation that costs between US\$8000 to \$10000, depending upon size. This particular model includes a receiving belt, washer, water absorber, and sorting table. Optional equipment includes eliminator, dry brusher, waxer, and a variety of sizers, rolling inspection belts, conveyor belts, and side tables.

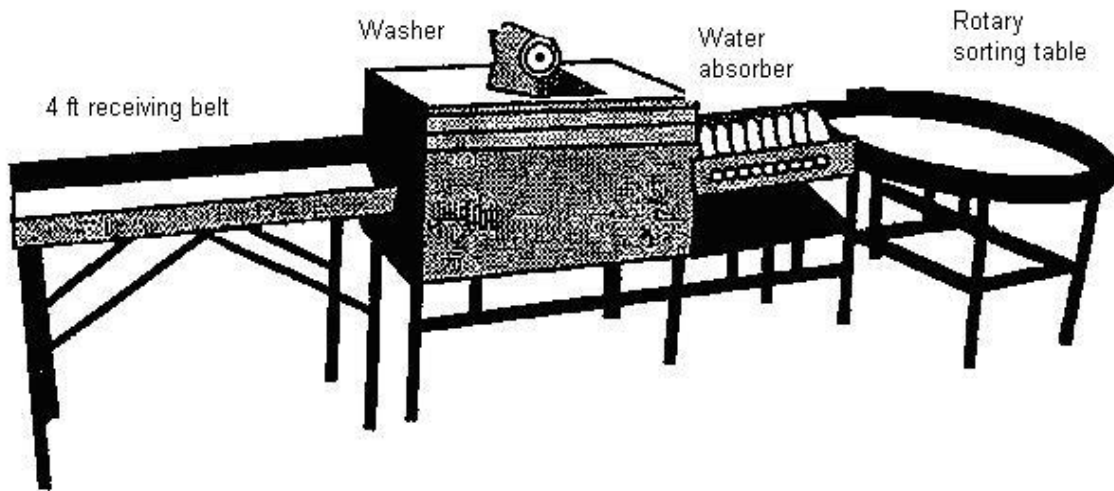

Source: 2001 Catalog of TEW Manufacturing Corporation, P.O. Box 87, Penfield, NY 14526 USA. [http://www.tewmfg.com/http://www.tewmfg.com/PDF\\_Files/Tew\\_2014\\_Catalog.pdf](http://www.tewmfg.com/http://www.tewmfg.com/PDF_Files/Tew_2014_Catalog.pdf)

# FRESH PRODUCE

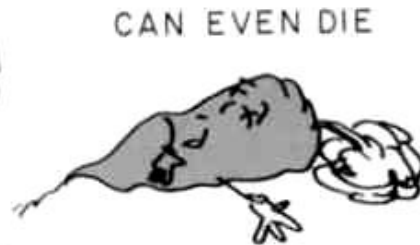

## **Chapter 4: Packing and Packaging Materials**

---

For most small-scale operations, hand packing is a major part of the postharvest handling system. While hand packing requires a lot of labor, produce can be hand packed to create a more attractive package, often using a fixed count of uniformly sized units (in molded trays or place packed, sometimes individually wrapped). Hand packing also allows you to package riper fruits and more delicate herbs and vegetables and provide buyers with great tasting, ready-to-eat produce. If you package ripe produce for specialty shops or create gift packs or gift baskets, these consumer packs will generally have to be packed into larger containers which will then provide more suitable protective packaging.

In addition to protection, packing and packaging allows quick handling throughout distribution and marketing and can minimize impacts of rough handling. Throughout the entire handling system, packaging can be both an aid and a hindrance to obtaining maximum storage life and quality. Packages need to be vented yet be sturdy enough to prevent collapse. If produce is packed for ease of handling, waxed cartons, wooden crates or rigid plastic containers are preferable to bags or open baskets; bags and baskets provide no protection to the produce when stacked.

Sometimes locally constructed containers can be strengthened or lined to provide added protection to produce. Waxed cartons, wooden crates and plastic containers, while more expensive, are cost effective when used for the domestic market. These containers are reusable and can stand up well against the high relative humidity found in the storage environment. Adding a simple cardboard liner to a wooden crate will make it less likely to cause abrasion to produce. Plastic crates can be used hundreds of times and are easy to clean between uses.

Containers should not be too large, since larger containers tend to be dropped more often and can lead to worker injuries. Using smaller packages may cost a bit more, but the reduced damage will improve financial returns. Package liners and smaller packages are highly cost effective ways of improving earnings with very little financial investment. Field trials conducted in Africa and India during 2009-10 showed that decreasing the size of huge packages (sacks, wooden crates, and baskets) could decrease losses by 30% (Kitinoja, 2010).

For best results, containers should not be filled too loosely or too tightly. Loose products may vibrate against others and cause bruising, while over packing results in compression bruising. Shredded newspaper is an inexpensive and lightweight filler for shipping containers (Harvey et al., 1990).

For small-scale handlers interested in constructing their own cartons from corrugated fiberboard, Broustead and New (1986) provide detailed information. Many types of agricultural fibers are suitable for paper making (Hunsigi, 1989), and handlers may find it economically sensible to include these operations in their postharvest system. As described by Thompson, corrugated fiberboard is manufactured in four flute types—type

B (1/8 inch in height, 47 to 53 flutes per inch, with a basis weight of 26 lb. per 1,000 ft<sup>2</sup>) is the most commonly used for handling perishables (as cited in Kader, 2002).

Whenever packages are handled in a high humidity environment, much of their strength is lost. Collapsed packages provide little or no protection, forcing the commodity inside to support all the weight of the overhead load. Packaging is meant to protect the commodity by immobilizing and cushioning it, but temperature management can be made more difficult if packing materials block ventilation holes. Packaging materials can act as vapor barriers and can maintain higher relative humidity within the package, which is not always desirable.

Produce can be hand packed to create an attractive pack, often using a fixed count of uniformly sized units. Packaging materials, such as trays, cups, wraps, liners and pads, may be added to help immobilize the produce. Simple, mechanical packing systems often use the volume-fill method or tight-fill method in which sorted produce is delivered into boxes then vibration settled. Mitchell states that most volume-fillers are designed to use weight as an estimate of volume, and final adjustments are done by hand (as cited in Kader, 2002).

Ethylene absorber sachets placed into containers with ethylene sensitive produce can reduce the rate of ripening of fruits, de-greening of vegetables, or floral wilting.

Packaging in plastic films can modify the atmosphere surrounding the produce (modified atmosphere packaging or MAP). MAP generally restricts air movement, allowing the product's normal respiration processes to reduce oxygen content and increase carbon dioxide content of the air inside the package. An additional major benefit to the use of plastic films is the reduction of water loss.

MAP can be used within shipping containers and consumer units. Atmospheric modification can be actively generated by creating a slight vacuum in a vapor-sealed package (i.e. an un-vented polyethylene bag), and then replacing the package atmosphere with the desired gas mixture. In general, lowering oxygen and increasing carbon dioxide concentrations will be beneficial for most of the commodities known to benefit from MAP (see the tables of recommended gas mixtures for Controlled Atmospheres (CA) and Modified Atmospheres (MA) storage and transport of various crops, Chapter 7). Selection of the best polymeric film for each commodity/package size combination depends upon film permeability and the respiration rate of the commodity under the expected time/temperature conditions during handling. Absorbers of oxygen, carbon dioxide, and/or ethylene also can be used within packages or containers to help maintain the desired atmospheric composition.

Modified atmosphere packaging should always be considered as a supplement to proper temperature and relative humidity management. The differences between beneficial and harmful concentrations of oxygen and carbon dioxide for each kind of produce are relatively small, so great care must be taken when using these technologies.



## Best Practices for Packing and Packaging

| DO   | DO NOT   |
|--|--|
| Use sturdy packages capable of enduring handling, cooling and storage conditions (high humidity environments).   | Use very large packages. The larger the container, the more likely the produce will suffer damage during handling. |
| Line rough packages, such as baskets and wooden crates, with cardboard inserts.  | Overload packages or allow produce to bulge over the sides.  |
| Reinforce packages used for heavy produce with corner supports or folded dividers.   | Pack the produce too tightly or too loosely.   |
| Packages should be vented about 5% of the surface area per side.   | Block the ventilation holes of packages with fillers or liners.  |
| Use shallow packages for delicate produce such as berries, grapes, summer squash, and ripe stone fruits (single layer or double layers).                                       |  |
| Consider using packaging materials, such as trays, cups, wraps, liners, and pads, to help immobilize and protect produce, but don't overdo it.                                 |  |
| Small, rigid plastic containers, such as clamshell baskets (consumer-sized containers placed into larger boxes), are useful for protecting berries from damage and water loss. |  |
| Liners made of perforated plastic films will decrease the rate of water loss from produce such as cherries.  |  |
| Make sure the packages you use for garlic and onions have plenty of ventilation (mesh bags will provide the lower humidity environment required for proper handling).          |  |
| Label containers with your logo or farm name for enhanced marketing (have cartons printed or use inexpensive paper labels or stickers).  |  |
| Consider using packages that can be used to display produce during marketing (printed sides, display materials on flaps).  |  |
| Pack "consumer packages," such as gift packs or display trays, into larger, more protective outer containers before stacking, transport, and marketing.                        |  |

| <b>DO</b>  | <b>DO NOT</b>  |
|--|--|
| Consider the use of packages with "hand-holds"-- these cutouts can reduce damage since they provide an easy way to pick up and carry produce.  |  |
| Use virgin/food grade materials whenever possible. Avoid wood, nails, and staples due to possible food safety problems.  |  |
| Consider the use of modified atmosphere packaging (MAP) for your specialty products (please read the section of this chapter on MAP if you are considering modified atmosphere packaging). | Use MAP if you are not also using refrigeration.                           |
| Use films that will not cause product fermentation (you must know the respiration rate of the produce at the temperature at which it will be handled).                                     | Use MAP on decayed or injured produce.                                     |
|  | Package mushrooms in MAP due to the risk of <i>Clostridium botulinum</i> . |
|  | Use MAP on overripe or senescent produce.                                  |

## Packing Practices

The packing stand illustrated in the diagram below can be bolted to a second stand of the same construction if more space is required for packing produce. When trimming is necessary, add a loose board thick enough to reach above the height of the front rail. The front rail should be smooth and rounded.

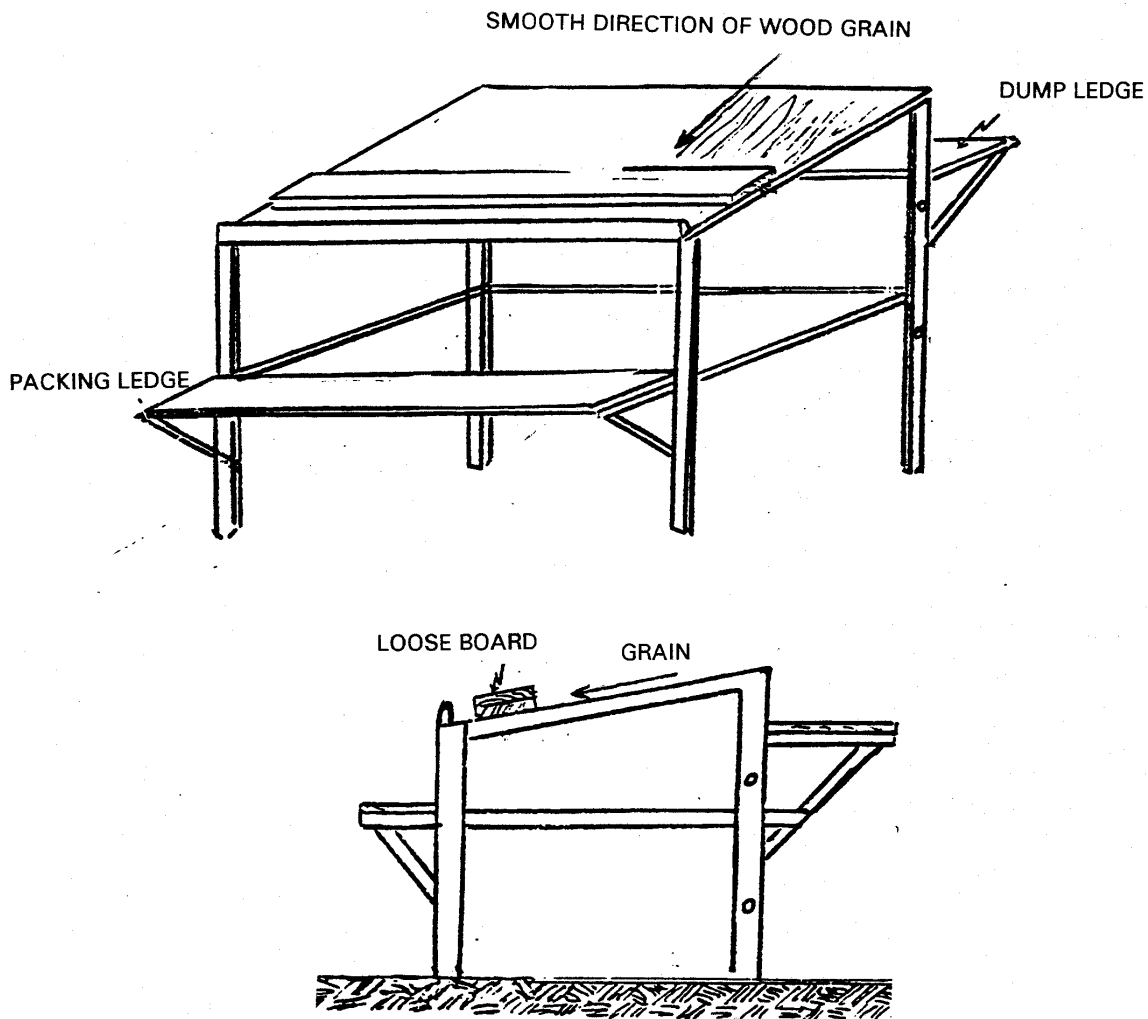

Source: Grierson, W. 1987. Postharvest Handling Manual: Commercialization of Alternative Crops Project. Belize Agribusiness Co./Chemonics International Consulting Division/USAID.

A simple field packing station can be constructed from wooden poles and a sheet of polyethylene. Thatch over the roof will provide shade and keep the station cool. The structure should be oriented so that the roof overhang blocks a majority of the sun's rays.

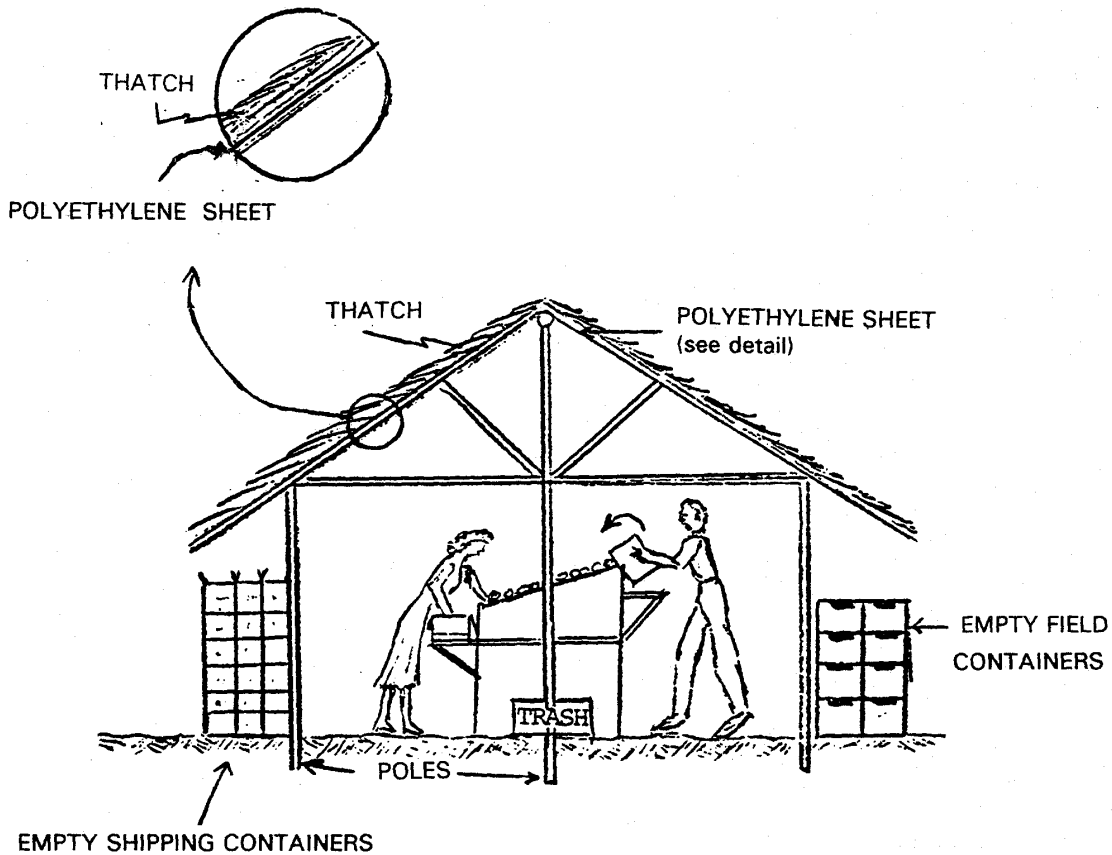

Source: Grierson, W. 1987. Postharvest Handling Manual: Commercialization of Alternative Crops Project. Belize Agribusiness Co./Chemonics International Consulting Division/USAID.

Hands of bananas, after undergoing washing to remove latex and perhaps spraying with fungicides, are typically packed into cardboard containers lined with polyethylene. The following illustrations depict one method of filling a container with the fruit to ensure less damage during transport. Note that the polyethylene liner is folded up over the bananas before closing the box.

(a) Wide, flat medium-to-small hand in middle of compartment



(b) Medium-length, wide hand on top, crown not touching fruit below



(c) Medium-to-short length, wide hand, crown not touching fruit below



(d) One large hand or two clusters with long fingers

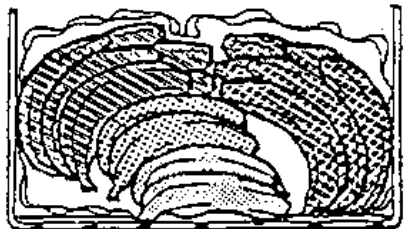

Source: FAO. 1989. Prevention of Postharvest Food Losses: Fruits. Vegetables and Root Crops. A Training Manual. Rome: UNFAO. p. 157.

A circular rotating table can be used to pack a variety of crops. The produce is fed in a long a conveyor or, if no conveyor is in use, simply placed on the table, where packers select the produce and fill cartons at their stations. In the illustration below, a discard belt is added below the supply belt, allowing for easy disposal of culls.

Each packer can work independently, trimming as needed and checking weighing cartons occasionally.

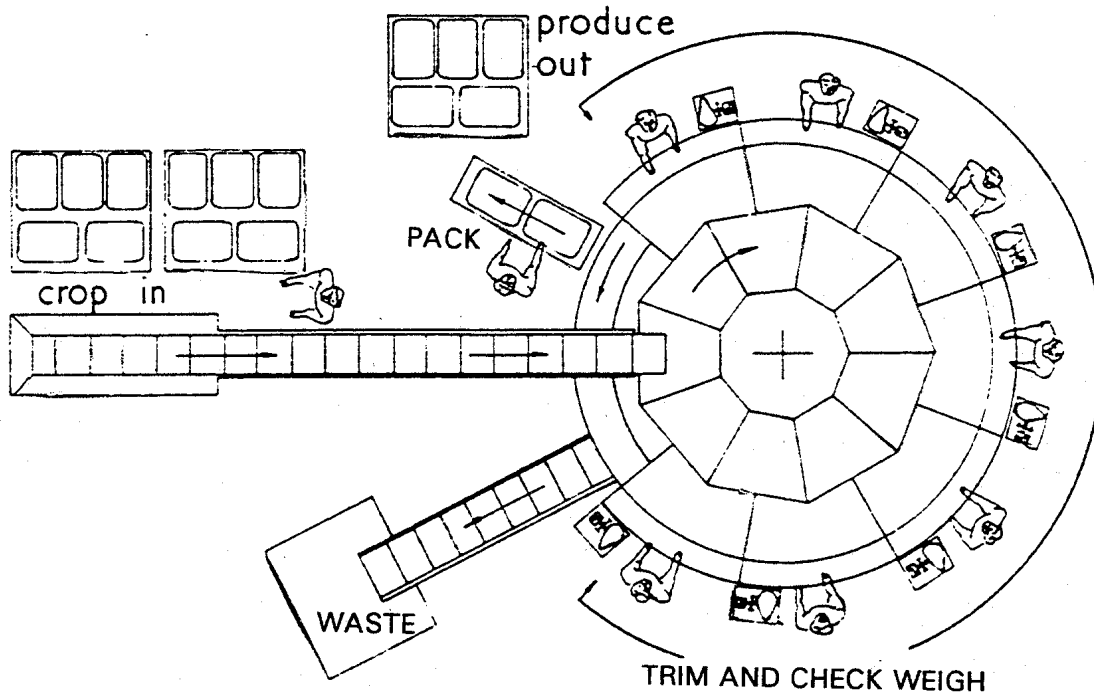

Source: National Institute of Agricultural Engineering. 1979. Preparing Vegetables for Supermarkets. Field Vegetable Department, Silsoe, Bedford: NIAE.

## Packing Containers

Sacks are often used to package produce, since they tend to be inexpensive and readily available. The following table provides some information regarding the characteristics of different kinds of materials used to make sacks. None of these types of sacks available are good for protecting fresh produce, thus should be avoided whenever possible.

### Characteristics of Sacks as Packaging Units

| Sack types     | Tearing and snagging | Impact    | Protection against                               |                                     | Contamination                                  | Notes  |
|----------------|----------------------|-----------|--|-------------------------------------|--|--|
|                |                      |           | Moisture absorption                              | Insect invasion                     |  |  |
| Jute           | Good                 | Good      | None   | None                                | Poor, also cause contamination by sack fibers. | Bio-deterioration. Insect harborage. Odor retention.       |
| Cotton         | Fair                 | Fair      | None   | None                                | Fair   | High re-use value.   |
| Woven plastics | Fair-Good            | Good      | None   | Some protection (if closely woven)  | Fair   | Badly affected by ultra-violet light. Difficult to stitch. |
| Paper          | Poor                 | Fair-Poor | Good - WFP multi-wall sacks have plastic liners. | Some protection, better if treated. | Good   | Consistent quality. Good print.                            |

Source: Walker, D.J. (ed.). 1992. World Food Programme Food Storage Manual. Chatham, UK: Natural Resources Institute.

The table below provides examples of some types of typical mechanical damage and their effect on packaging containers.

| <b>Type of damage</b>                    | <b>Container</b>            | <b>Result</b>   | <b>Important factors</b>            |
|--|-----------------------------|---|-------------------------------------|
| Impact damage through dropping           | Sacks - woven and paper     | Splitting of seams and material causing leaking and spillage loss.  | Seam strength                       |
|  | Fiberboard boxes            | Splitting of seams, opening of flaps causing loss of containment function. Distortion of shape reducing stacking ability. | Bursting strength<br>Closure method |
|  | Wooden cases                | Fracture of joints, loss of containment function.   | Fastenings<br>Wood toughness        |
|  | Cans and drums              | Denting, rim damage. Splitting of seams and closures causing loss of containment and spoilage of contents.                |                                     |
|  | Plastic bottles             | Splitting or shattering causes loss of contents.  | Material grade<br>Wall thickness    |
| Compression damage through high stacking | Fiberboard boxes            | Distortion of shape, seam splitting causing loss of containment and splitting of inner cartons, bags, and foil wrappings. | Box compression strength            |
|  | Plastic bottles             | Distortion, collapse and sometimes splitting, causing loss of contents.   | Design, material, wall thickness    |
| Vibration                                | Corrugated fiberboard cases | Become compressed and lose their cushioning qualities. Contents more prone to impact damage.                              | Box compression strength            |
| Snagging, tearing, hook damage           | Sacks - woven and paper     | Loss of containment function - spillage (more severe with paper sacks).   | Tear strength                       |
|  | Tins                        | Punctured, loss of contents.  | Metal thickness                     |

Source: Walker, D.J. (ed.). 1992. World Food Programme Food Storage Manual. Chatham, UK: Natural Resources Institute.



The diagrams below are for a variety of commonly used fiberboard containers. Final dimensions can be altered to suit the needs of the handler, and all containers should have adequate vents added (5% of the surface area per side). Cartons can be glued, taped or stapled as desired during construction at the packinghouse.

**One-piece Box:**

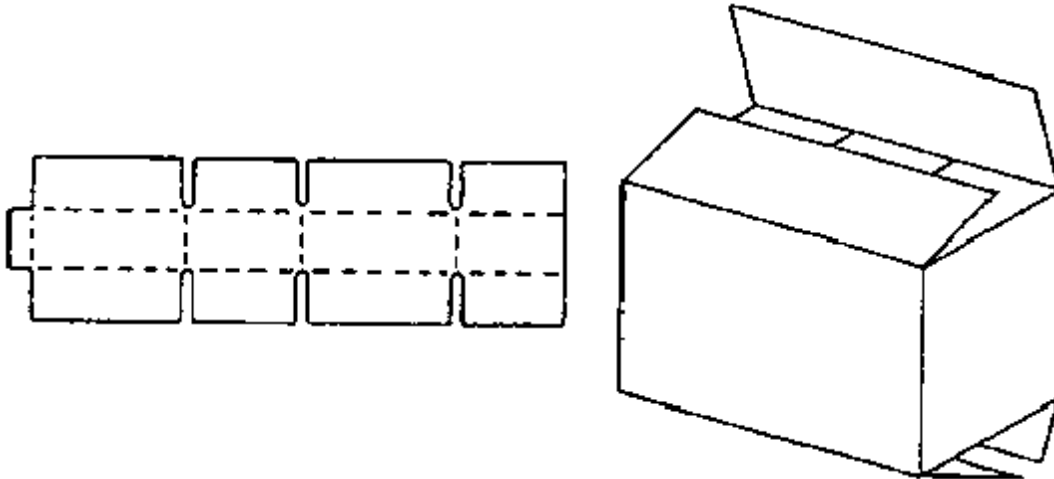

**Two-piece Box with Cover:**

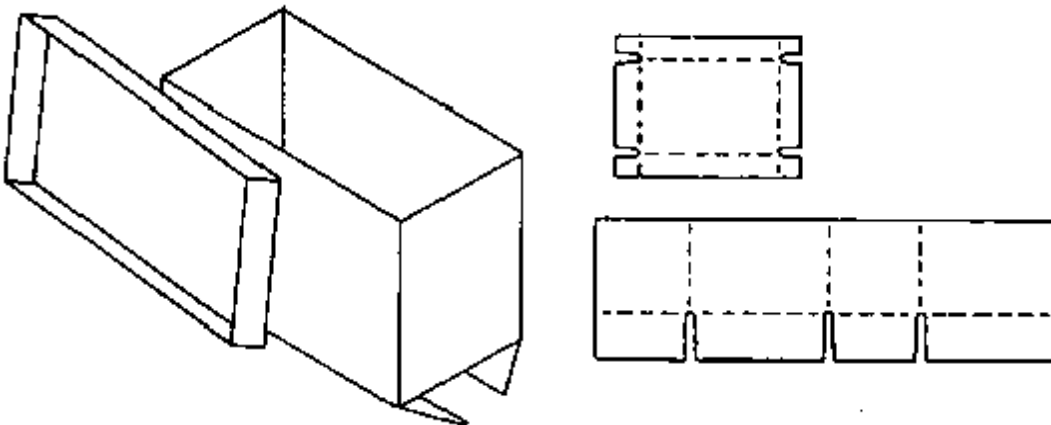

Source: McGregor, B. 1987. Tropical Products Transport Handbook. USDA, Office of Transportation, Agricultural Handbook Number 668.

The diagrams below are for a variety of commonly used fiberboard containers. Final dimensions can be altered to suit the needs of the handler, and all containers should be adequately vented (5% venting of the surface area on each side).

**Bliss-style Box:**

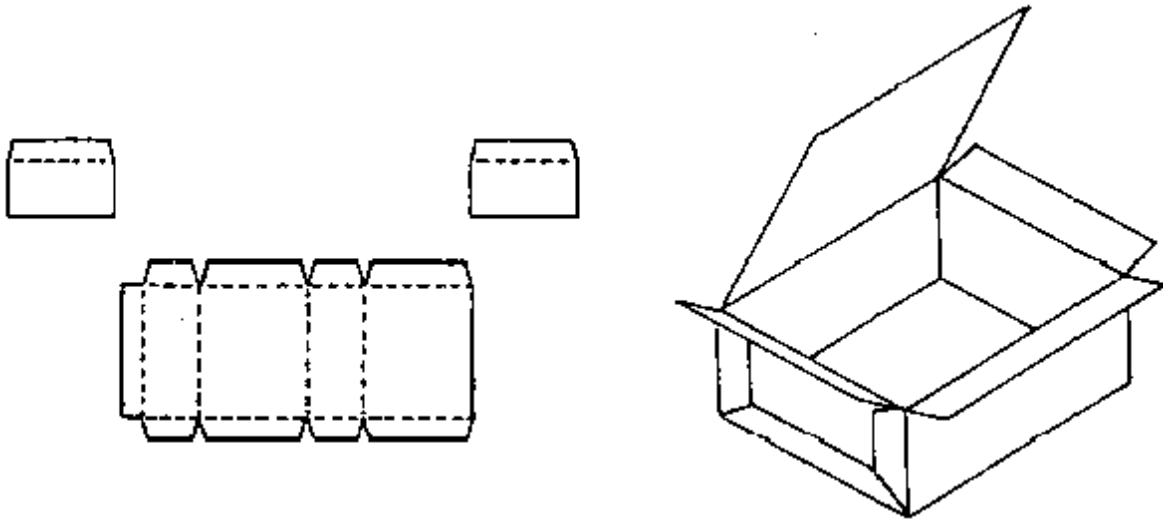

**Full telescoping Box:**

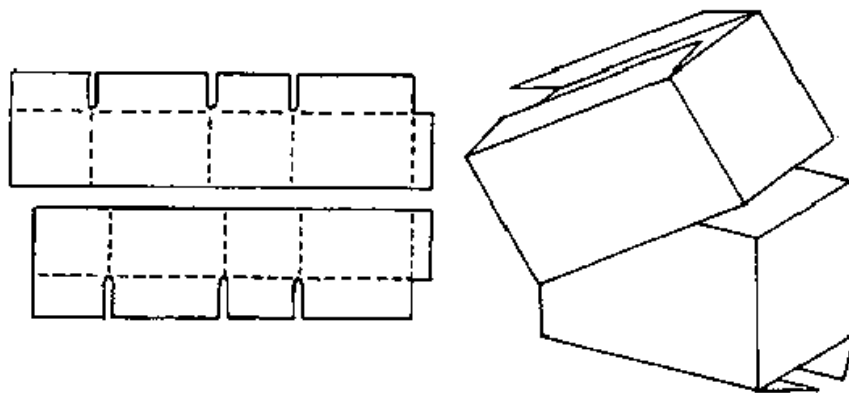

Half- or full-telescopic containers have the highest stacking strength and protect against bulging but are more costly. The container, known as a Bliss box, has very strong corners but is not collapsible. Your choice of package style will depend on what commodity you pack and how you intend to use the container throughout the postharvest system (during cooling, for long-term storage, or as a display).

Source: McGregor, B. 1987. Tropical Products Transport Handbook. USDA, Office of Transportation, Agricultural Handbook Number 668.

The diagrams below are for a variety of commonly used fiberboard containers.

**Self-locking Tray:**

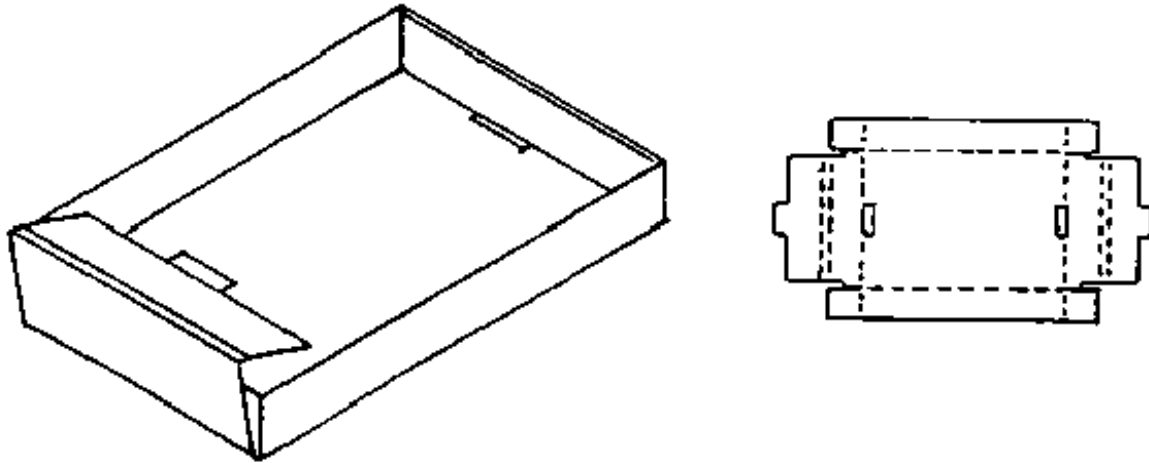

**Interlocking Box:**

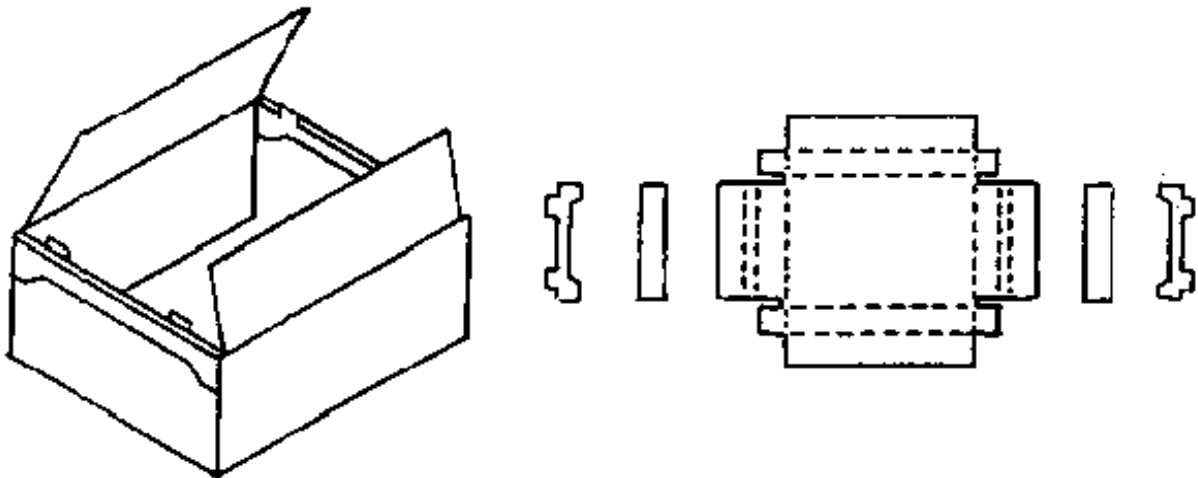

Source: McGregor, B. 1987. Tropical Products Transport Handbook. USDA, Office of Transportation, Agricultural Handbook Number 668.

Containers can be constructed from wood and wire, using the general diagrams provided below. A special closing tool makes bending the wire loops on the crate's lid easier for packers. Wire-bound crates are used for many commodities including melons, beans, eggplant, greens, peppers, squash, and citrus fruits. Package Research Laboratory (41 Pine Street, Rockaway, New Jersey 07866) can provide a list of suppliers in your area and offers package testing services to help determine the proper package for your products.

<http://www.package-testing.com/package-testing.html>

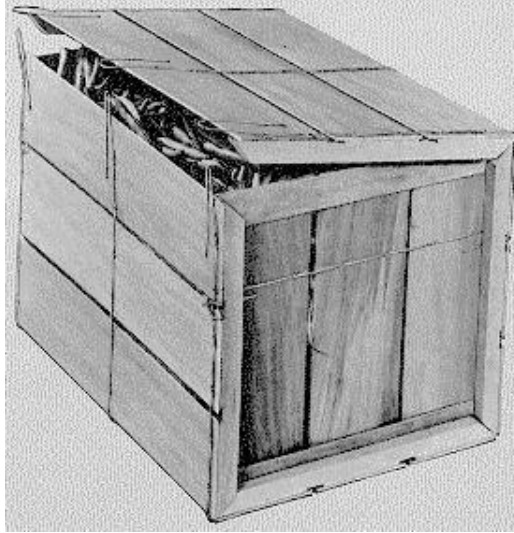

Half-sized crates were developed and tested in 2013 for a UC Davis Horticulture Innovation Lab project in Tanzania. These smaller wooden crates were compared to large, rough crates currently in use for packing and transporting ripe tomatoes. By using smaller crates, damage was reduced to less than half. Sanding the inner surfaces to reduce roughness will further decrease damage.



Here is a simple illustration of the parts of a wooden crate.

Ends:

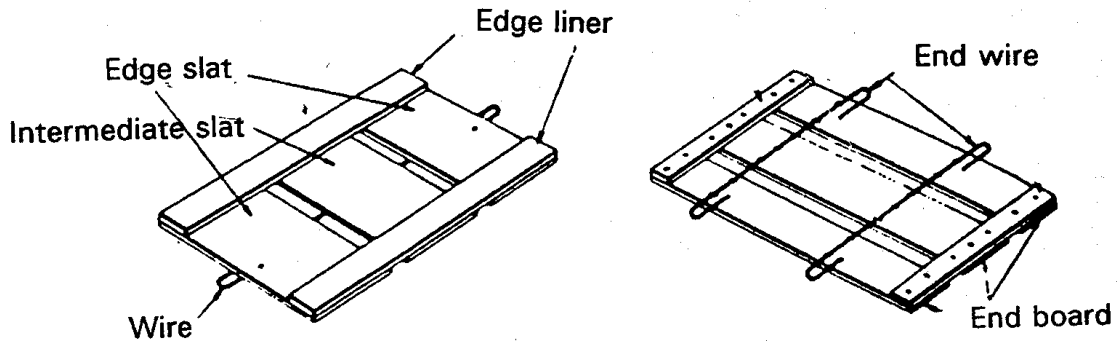

Blank for body:

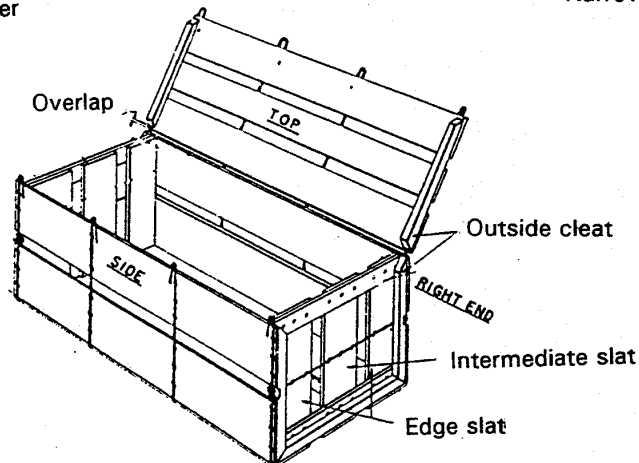
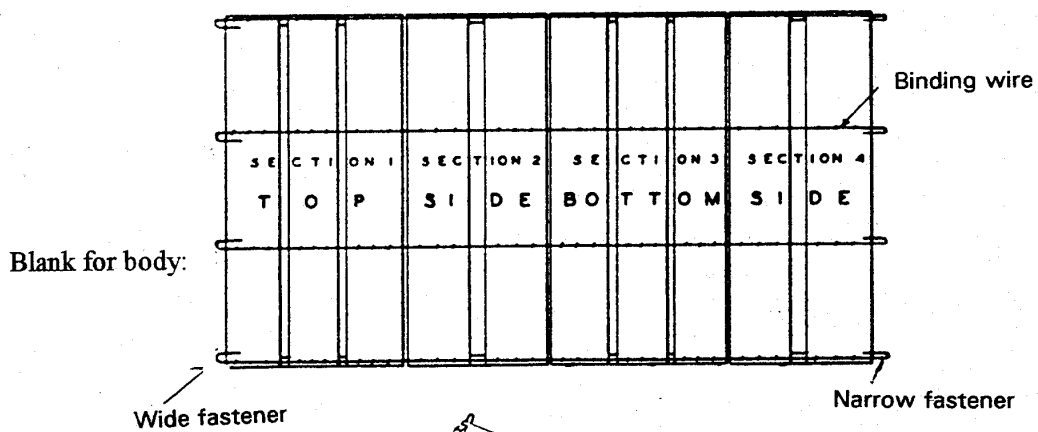

Source: Peleg, K. 1985. Produce Handling Packaging and Distribution. Westport, Conn.: AVI publishing Co., Inc.

A wooden lug is the typical packing container for table grapes. This container is very sturdy and maintains its stacking strength over long periods of time at high relative humidity. Rigid plastic containers are also widely used.

Often, a paper liner is folded over the grapes before the top is nailed shut. The liner protects the produce from dust and water condensation. When needed, a pad containing sulfur dioxide can be enclosed with the grapes within a plastic liner as a treatment to control decay. Most commodities other than table grapes can be damaged (bleached) by sulfur dioxide treatments.

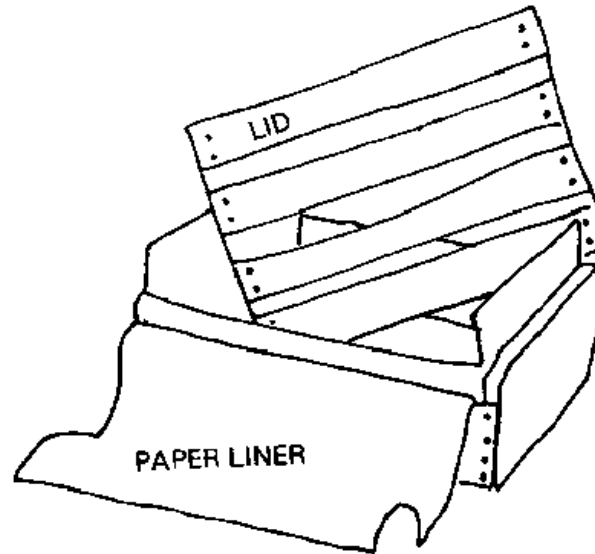

Rigid plastic or wooden containers are also used extensively for asparagus. The trimmed spears are packed upright in containers that provide a large amount of ventilation.



For domestic marketing, plastic crates provide excellent protection for produce and adequate ventilation during handling, cooling, transport, and storage. Some plastic crates are collapsible or can be nested when stacked for easier handling when empty. Crates should be smooth inside to protect produce from abrasions. Crates should be cleaned on a regular basis with chlorinated water and detergent to reduce the chances of spreading decay from one load to the next.

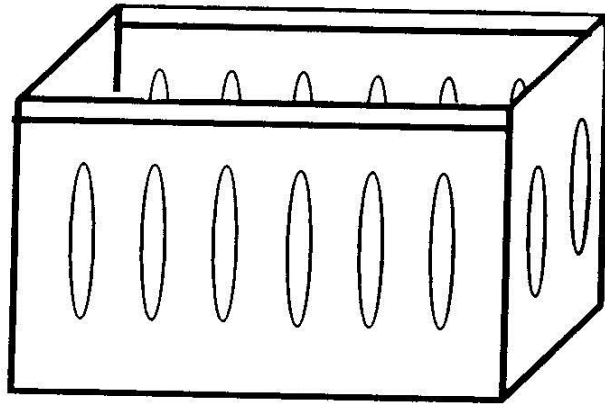

Source: <http://www.movingauthorities.com/folding-plastic-crates/>

Containers for cut flowers are often long and narrow and have a telescopic design with vents at both ends to facilitate forced-air cooling. The total vent area should be at least 5% of the total box surface area. A closable flap can help maintain cool temperatures if boxes are temporarily delayed in transport or storage in an uncontrolled temperature environment.

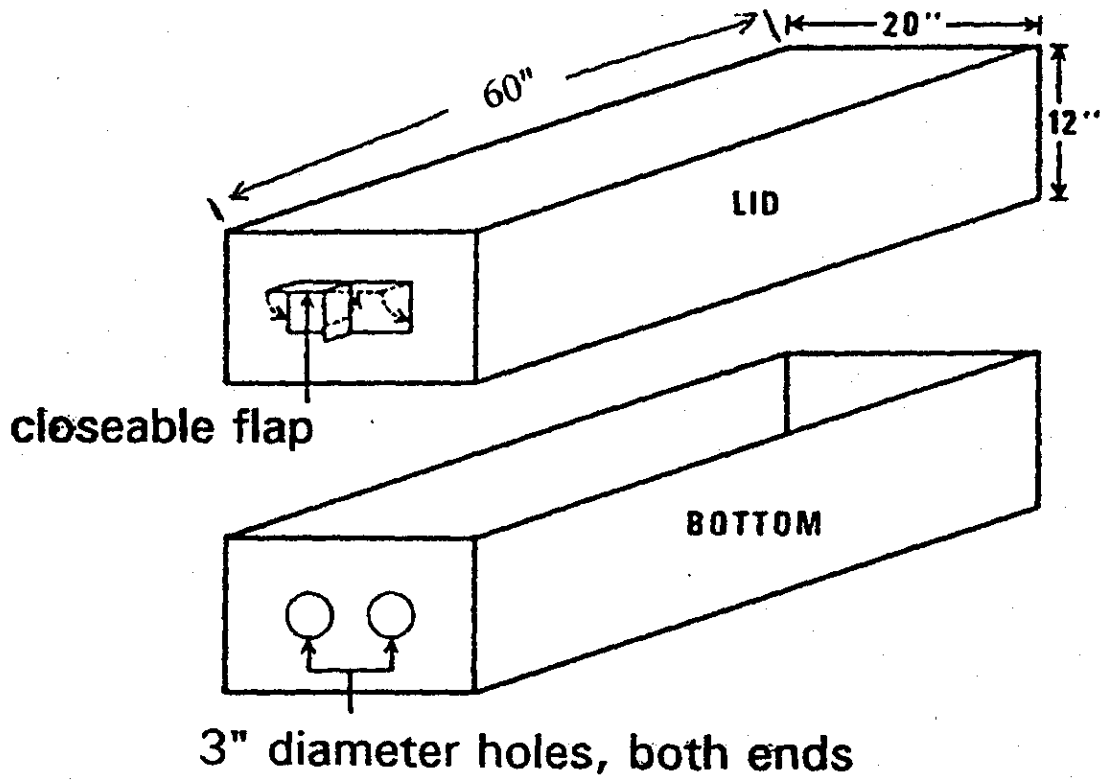

Source: Rij, R.E. et al. 1979. Handling, precooling and temperature management of cut flower crops for truck transportation. USDA Science and Education Administration (Issued jointly as University of California Division of Agricultural Sciences Leaflet 21058). AAT-W-5. p. 26.



A simple wooden tray with raised corners is stackable and allows plenty of ventilation for fragile crops such as ripe tomatoes.

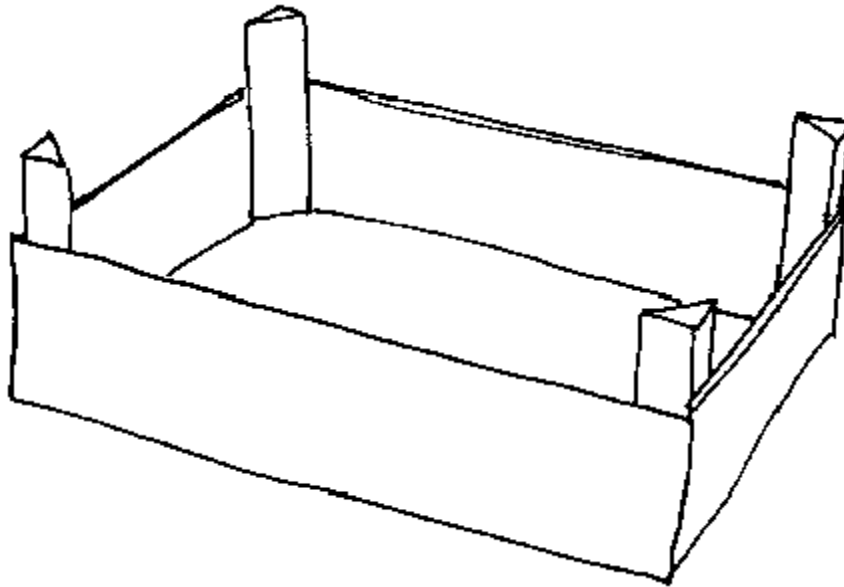

Source: FAO. 1985. Prevention of Post-Harvest Food Losses: A Training Manual. Rome: UNFAO. p. 120.

## Choosing a Container

Choosing a container can often be a complex decision. There are always trade-offs to consider with respect to price, durability, reusability and protection. Here is a checklist of factors to consider when selecting a container from two or more package types. Use as many copies of this table as required to compare all your packaging options.

Describe each package type then fill out the table to see which package has the most positive characteristics and, therefore, will be the best choice for the intended market.

1) Give ratings to the characteristics for different types of packaging.

|    |                        |
|----|------------------------|
| +2 | = excellent            |
| +1 | = good                 |
| 0  | = fair                 |
| -1 | = unsuitable           |
| -2 | = extremely unsuitable |

2) Give each characteristic a value from 0 to 100. The total for all 24 characteristics for each package should add up to 100.

3) Multiply each package's rating for each characteristic by its value and record the new value.

4) Add up the total points for each type of package. Does the package that received the most points match your preference? What are the differences between the two packages with the highest score? If one is lower in price that may be your best choice.

|   | Package #1 ratings | Package #1 values | Multiply rating x value | Package #2 ratings | Package #2 values | Multiply rating x value |
|---|--------------------|-------------------|-------------------------|--------------------|-------------------|-------------------------|
| Describe package  |                    |                   |                         |                    |                   |                         |
| <b>CONTAINING</b>   |                    |                   |                         |                    |                   |                         |
| 1. Suitable capacity for the range of produce                   |                    |                   |                         |                    |                   |                         |
| 2. Easily handled by one person                                 |                    |                   |                         |                    |                   |                         |
| 3. Has standard design and meets standards and marketing demand |                    |                   |                         |                    |                   |                         |
| 4. Palletization ease   |                    |                   |                         |                    |                   |                         |
| <b>PROTECTING</b>   |                    |                   |                         |                    |                   |                         |
| 5. Stable when stacked  |                    |                   |                         |                    |                   |                         |
| 6. Consistent dimension resists the pressure when stacked       |                    |                   |                         |                    |                   |                         |
| 7. Good ventilation   |                    |                   |                         |                    |                   |                         |
| 8. Protection during handling, transport and marketing          |                    |                   |                         |                    |                   |                         |
| 9. Smooth surface material, no sharp edges                      |                    |                   |                         |                    |                   |                         |
| 10. Liners available  |                    |                   |                         |                    |                   |                         |
| 11. Easy to clean   |                    |                   |                         |                    |                   |                         |

|  |  |  |  |  |  |  |
|--|--|--|--|--|--|--|
| 12. Pilfer proof/closed with cover               |  |  |  |  |  |  |
| <b>COMMUNICATING</b>                             |  |  |  |  |  |  |
| 13. Easy to attach label                         |  |  |  |  |  |  |
| 14. Advertisement/ brand name on box             |  |  |  |  |  |  |
| <b>MARKETING</b>                                 |  |  |  |  |  |  |
| 15. Presentation                                 |  |  |  |  |  |  |
| 16. Acceptable for customs control               |  |  |  |  |  |  |
| <b>COST-MISCELLANEOUS</b>                        |  |  |  |  |  |  |
| 17. Reasonable purchase cost                     |  |  |  |  |  |  |
| 18. Durable/ deterioration                       |  |  |  |  |  |  |
| 19. Repairable                                   |  |  |  |  |  |  |
| 20. Consistent supply guaranteed                 |  |  |  |  |  |  |
| 21. Low cargo volume when empty                  |  |  |  |  |  |  |
| 22. Local manufacturing possible                 |  |  |  |  |  |  |
| 23. Transporting/ fitting on pick-up or handcart |  |  |  |  |  |  |
| 24. Loss of crates                               |  |  |  |  |  |  |
| <b>TOTAL POINTS</b>                              |  |  |  |  |  |  |

Source: Schuur, C.C.M. 1988. Packaging for fruits, vegetables and root crops. Food and Agriculture Organization of the United Nations, Bridgetown, Barbados.

## Packaging Practices

Adding a fiberboard divider to a carton will increase stacking strength. The use of dividers is common with heavy crops such as melons. The dividers also prevent melons from vibrating against one another during handling and transport. Wooden inserts or fiberboard folded into triangles and placed in all four corners can be especially useful when a carton needs strengthening.

### Fiberboard Divider:

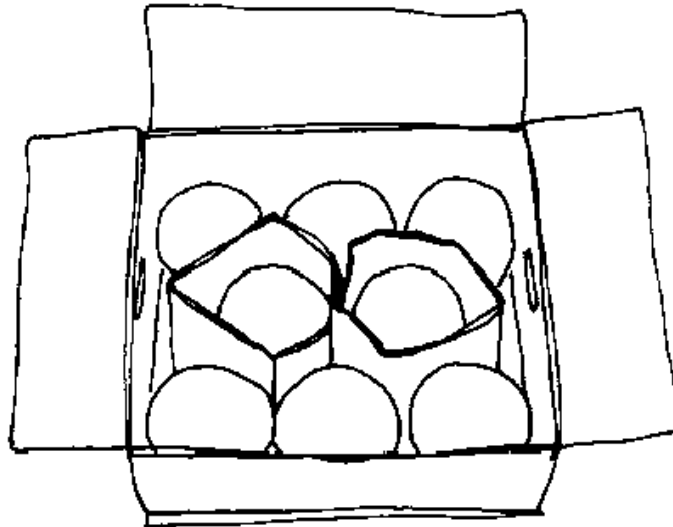

Source: McGregor, B. 1987. Tropical Products Transport Handbook. USDA, Office of Transportation, Agricultural Handbook Number 668.

### Triangular Corner Supports:

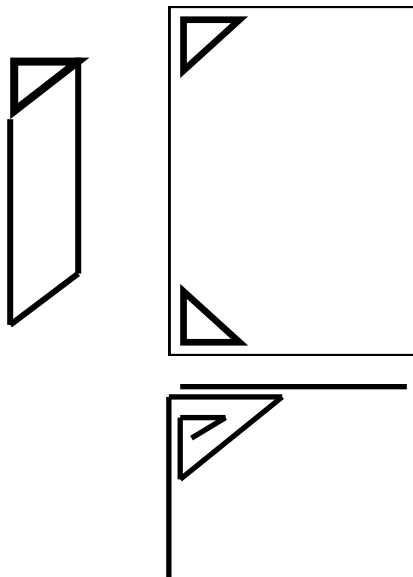

Simple corner supports can be made from wooden blocks or folded fiberboard.

The fiberboard used to construct the carton corners can be folded inward to reinforce the corner and increase stacking strength.

When locally made containers have sharp edges or rough inner surfaces, a simple, inexpensive, inner piece made from fiberboard can be used to protect produce from damage during handling.

**Cardboard Liner for a Palm Rib Crate:**

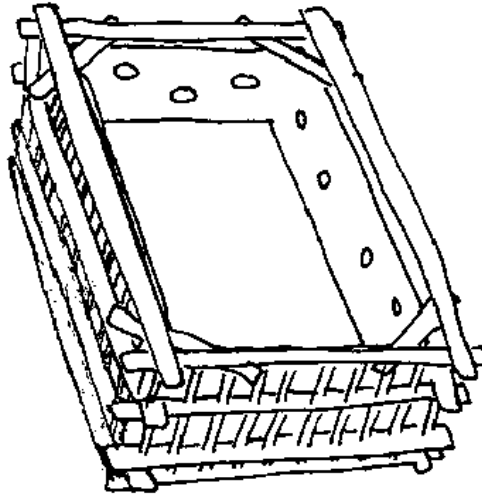

Source: Blond, R.D. 1984. The Agricultural Development Systems Project in Egypt (1979-83). USAID/Ministry of Agriculture, Egypt/University of California, Davis.

**Liner for a Wooden Crate:**



Photo: L. Kitinoja, Morocco.

If large bags or baskets must be used for bulk packaging of fruits or vegetables, the use of a simple vent can help reduce the buildup of heat as the product respire. In the illustration below, a tube of woven bamboo (about one meter long) is used to vent a large bag of chili peppers. Place the vent tube into the container before filling the container with the product.

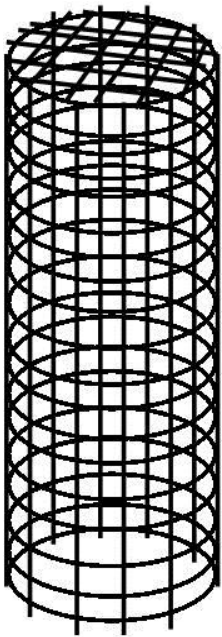
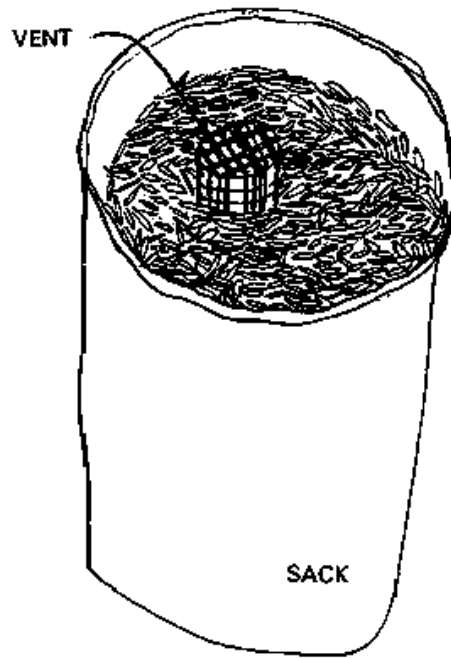

The woven bamboo tube allows air to reach the center of the sack or basket during handling.

Thin paper or plastic sleeves are a useful material for protecting cut flowers from damage during handling and transport. In the illustration below, a packer is pulling a sleeve up over a bunch of flowers before packing the flowers into a vented fiberboard carton. The sleeves provide both protection and separation inside the box for the flower bunches.

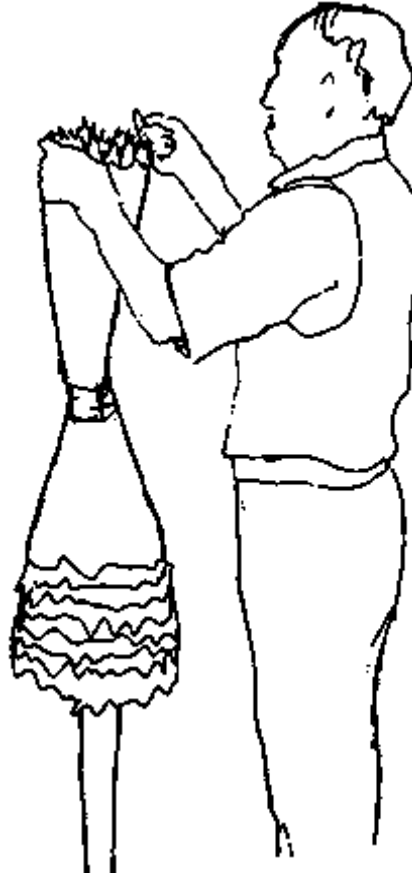

Source: Kader, A.A. (ed.). Postharvest Technology of Horticultural Crops. University of California, Division of Agriculture and Natural Resources. Publication 3311.

## Labeling

Labeling packages helps handlers keep track of the produce as it moves through the postharvest system, and assists wholesalers and retailers in using proper practices. Labels can be preprinted on fiberboard boxes but can also be glued, stamped, or stenciled onto containers. Brand labeling packages can aid in advertising for the product's producer, packer and/or shippers. Some shippers also provide brochures detailing storage methods or recipes for consumers.

Shipping labels can contain some or all of the following information:

- Common name of the product
- Net weight, count and/or volume
- Brand name
- Name and address of packer or shipper
- Country or region of origin
- Size and grade
- Recommended storage temperature
- Special handling instructions
- Names of approved waxes and/or pesticides used on the product

Labeling of consumer packages is mandatory under FDA regulations. Labels must contain the name of the product, net weight, and name and address of the producer, packer or distributor.

Source: McGregor, B. 1989. Tropical Products Transport Handbook. USDA, Office of Transportation. Agricultural Handbook Number 668.



## Modularization of Containers

When a variety of different sized cartons are packed at the same time, using boxes in standard sizes can greatly ease future handling. When handling boxes that are non-uniform, stacks can be unstable or heavier cartons can crush lighter ones. An unstable load is likely to fall over during transport or collapse during storage.

Recommended container sizes are shown below. These containers are part of the MUM program (Modularization, Unitization and Metrication) advocated by the USDA. They can all be stacked in a variety of patterns depending upon their size, yet still form a stable load on a single pallet of 1000 x 1200 mm (40 x 48 inches).

MUM containers for horticultural crops:

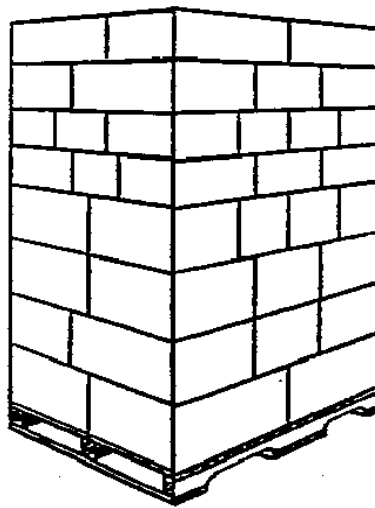

| Outside Dimensions |                 | Number per Layer | Pallet Surface Area Utilized |
|--------------------|-----------------|------------------|------------------------------|
| mm                 | Inches          |                  | Percentage                   |
| 600 x 500          | (23.62 x 19.69) | 4                | 100                          |
| 500 x 400          | (19.68 x 15.75) | 6                | 100                          |
| 600 x 400          | (23.62 x 15.75) | 5                | 100                          |
| 500 x 333          | (19.68 x 13.11) | 7                | 97                           |
| 600 x 333          | (23.62 x 13.11) | 6                | 99                           |
| 500 x 300          | (19.68 x 11.81) | 8                | 100                          |
| 475 x 250          | (18.70 x 9.84)  | 10               | 99                           |
| 400 x 300          | (15.75 x 11.81) | 10               | 100                          |
| 433 x 333          | (17.01 x 13.11) | 8                | 96                           |
| 400 x 250          | (15.74 x 9.84)  | 12               | 100                          |

### An Example of a Pallet Load of MUM Containers:

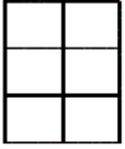
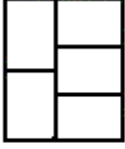
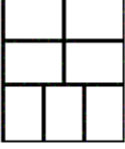

Source: Ashby, B.H. et al. 1987. Protecting Perishable Foods During Transport by Truck. Washington, D.C.: USDA, Office of Transportation, Agricultural Handbook No. 669.

The following illustrations show the arrangement of the most popular MUM containers on a standard pallet (1000 x 1200 mm or 40 x 48 inches). Using MUM containers can save space during transport and storage, since pallet utilization is close to 100%.

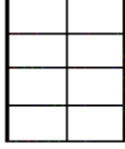
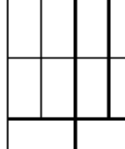
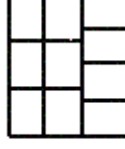
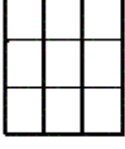
|   |   |   |   |   |   |
|---|---|---|---|---|---|
| <p>Outside dimensions:<br/>600 x 500<br/>mm<br/>(23.62 x<br/>19.69")<br/>Pallet<br/>utilization:<br/>100%</p> |    | <p>Outside dimensions:<br/>500 x 400<br/>mm<br/>(19.68 x<br/>15.75")<br/>Pallet<br/>utilization:<br/>100%</p> |    | <p>Outside dimensions:<br/>600 x 400<br/>mm<br/>(23.62 x<br/>15.75")<br/>Pallet<br/>utilization:<br/>100%</p> |    |
| <p>Outside dimensions:<br/>500 x 333<br/>mm<br/>(19.68 x<br/>13.11")<br/>Pallet<br/>utilization:<br/>97%</p>  |    | <p>Outside dimensions:<br/>600 x 333<br/>mm<br/>(23.62 x<br/>13.11")<br/>Pallet<br/>utilization:<br/>99%</p>  |    | <p>Outside dimensions:<br/>500 x 300<br/>mm<br/>(19.68 x<br/>11.81")<br/>Pallet<br/>utilization:<br/>100%</p> |    |
| <p>Outside dimensions:<br/>475 x 250<br/>mm<br/>(18.62 x<br/>9.84")<br/>Pallet<br/>utilization:<br/>99%</p>   |  | <p>Outside dimensions:<br/>400 x 300<br/>mm<br/>(15.75 x<br/>11.81")<br/>Pallet<br/>utilization:<br/>100%</p> |  | <p>Outside dimensions:<br/>400 x 333<br/>mm<br/>(15.75 x<br/>13.11")<br/>Pallet<br/>utilization:<br/>99%</p>  |  |

Source: McGregor, B. 1989. Tropical Products Transport Handbook. USDA, Office of Transportation, Agricultural Handbook Number 668.

## Modified Atmosphere Packaging (MAP)

### MAP within a consumer package

If commodity and film permeability characteristics are properly matched an appropriate atmosphere can evolve passively through consumption of  $O_2$  and production of  $CO_2$  during respiration (Kader, 2002). Some rigid plastic consumer packages are designed with a gas diffusion window.

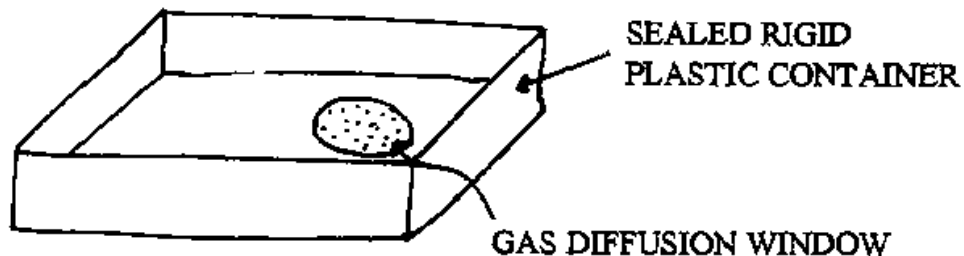

Fresh-cut or lightly processed lettuce (shredded or chopped) can be packaged in 5-mm plastic bags. After a partial vacuum is created, a gas mixture of 30 to 50%  $O_2$  and 4 to 6%  $CO_2$  is introduced into the bag, which is then sealed.

### SEALED PLASTIC BAG

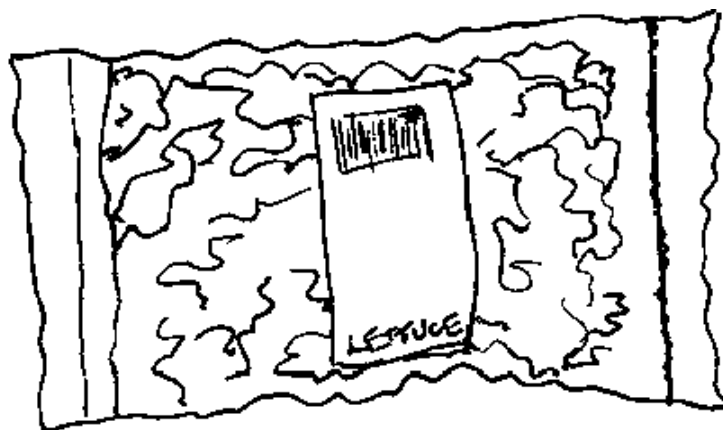

### MAP within a shipping container

Polyethylene liners are added to shipping containers in cherry boxes, and polyethylene bags are used for bananas destined for distant markets.

Using a polyethylene liner in a fiberboard carton can help protect produce and reduce water loss in commodities such as cherries, nectarines, kiwifruits, bananas, and herbs. Water vapor given off by the product is contained within the liner, increasing the RH around the product and decreasing the rate of water loss. The liner can also reduce abrasion damage that results from fruit rubbing against the inside of the box. It is important to keep produce cool to prevent damage in cartons lined with polyethylene due to gas composition changes related to increased respiration rates.

#### Polyethylene liner for shipping cherries:

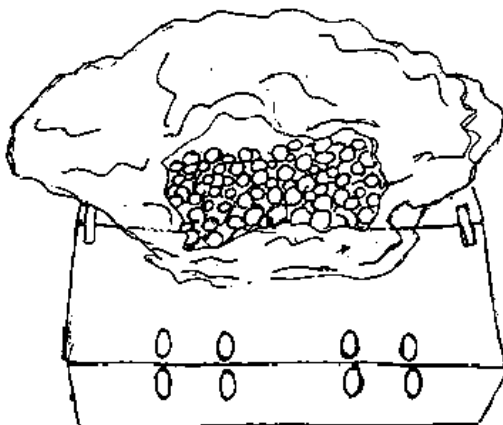

Never use un-perforated plastic bags to store onions or garlic -- the relative humidity (RH) inside the bag will become too high for proper handling and storage. Losses due to rooting, sprouting, and decaying postharvest will increase dramatically.

**Thompson (1996) reported that perforated film bags used for onion storage resulted in the following rates of rooting:**

|                                    |            |
|------------------------------------|------------|
| No perforations (98% RH)           | 71% rooted |
| 36 perforations of 1.6mm (88% RH)  | 59% rooted |
| 16 perforations of 6.4mm (54% RH)  | 17% rooted |
| 32 perforations of 6.4mm (51 % RH) | 4% rooted  |

Source: Thompson, A.K. 1996. Postharvest Technology of Fruit and Vegetables. Oxford: Blackwell Science.

## MAP within a pallet

A single pallet load of produce, such as strawberries, can be sealed within a shroud of 5 mm. polyethylene bag and a plastic sheet on the pallet base using wide tape. A slight vacuum can be introduced and 15% CO<sub>2</sub> added to the air introduced via a small hose.

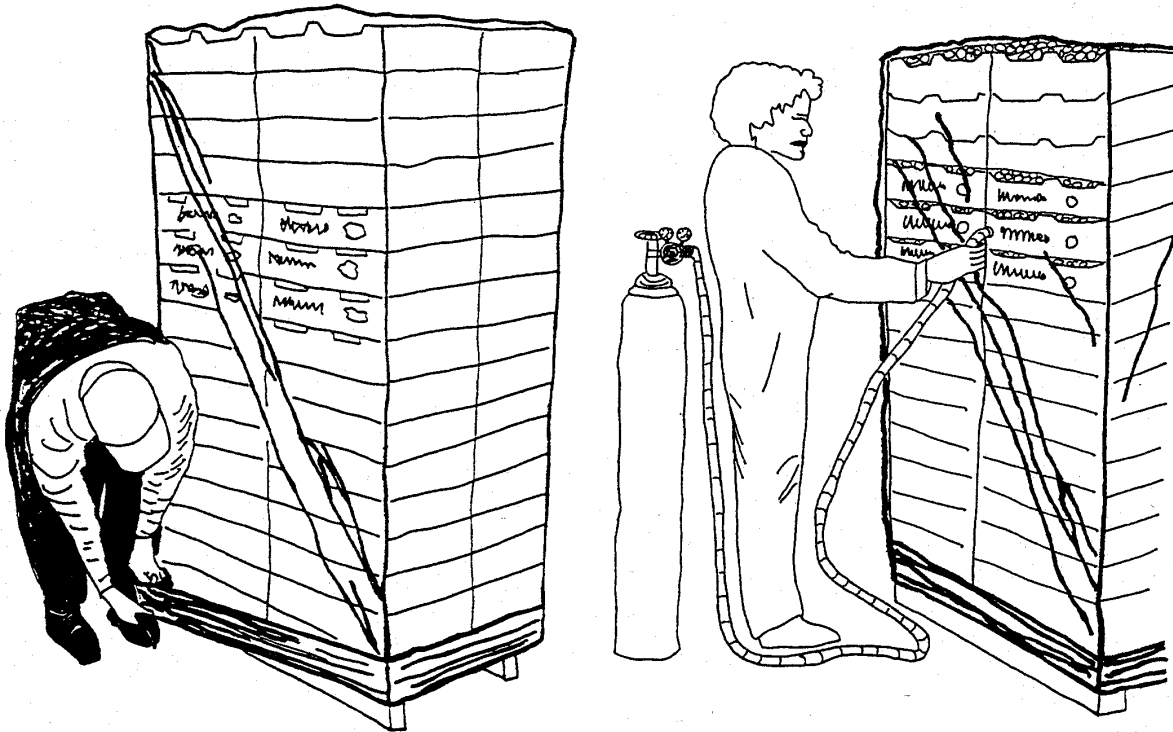

Many plastic films are available for packaging, but very few have gas permeability that makes them suitable for MAP. Low density polyethylene (LDPE) and polyvinyl chloride (PVC) are the main films used in packaging fresh fruits and vegetables. Saran and polyester have such low gas permeability that they are suitable only for commodities with very low respiration rates. The following table provides the permeability of the films currently available for packaging fresh produce (Kader, 2002).

| Film type                 | Permeability (cc/m <sup>2</sup> /mm/day at 1 atm) |                | CO <sub>2</sub> :O <sub>2</sub> Ratio |
|---------------------------|---|----------------|---------------------------------------|
|                           | CO <sub>2</sub>                                   | O <sub>2</sub> |                                       |
| Polyethylene: low density | 7,700-77,000                                      | 3,900-13,000   | 2.0-5.9                               |
| Polyvinyl chloride        | 4,263-8,138                                       | 620-2,248      | 3.6-6.9                               |
| Polypropylene             | 7,700-21,000                                      | 1,300-6,400    | 3.3-5.9                               |
| Polystyrene               | 10,000-26,000                                     | 2,600-7,700    | 3.4-3.8                               |
| Saran                     | 52-150  | 8-26           | 5.8-6.5                               |
| Polyester                 | 180-390   | 52-130         | 3.0-3.5                               |

## Unit loads

Many shippers and receivers prefer handling unit loads of produce pallets rather than handling individual shipping containers. Switching to unit loads reduces handling, causes less damage to the containers and its produce inside, and allows faster loading/ unloading of transportation vehicles. If small scale handlers wish to use unit loads for shipping produce, either wooden pallets or slip sheets can serve as the base of the load. Using guides for aligning the boxes (i.e. placing the pallet to be loaded against the corner of a room, or building a set of "bounce boards" if the pallet is loaded outside) will stabilize the load. Wooden pallets must be made perfectly square for the pallet load to be as stable as possible.

Using fiberboard, plastic or wooden containers with vertical interlocking tabs can also help improve the unit load's stability. Containers must have holes for ventilation, which align when stacked squarely on top of one another. To reduce slipping, glue can be used between layers of containers and plastic netting, or plastic or metal straps can be added to secure the load. Corner-boards made from fiberboard, plastic, or metal help to provide for a stable unit load.

### Strapping and corner-boards on a unit load:

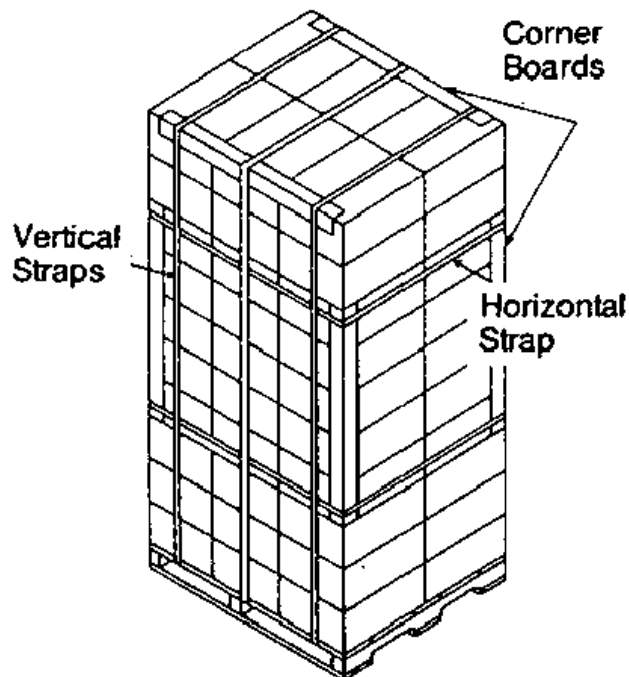

Sources: McGregor, B. 1989. Tropical Products Transport Handbook. USDA, Office of Transportation. Agricultural Handbook Number 668.

Ashby, B.H. et al. 1987. Protecting Perishable Foods During Transport by Truck. USDA, Office of Transportation. Agricultural Handbook Number 669.

## **Chapter 5: Decay and Insect Control**

---

The first line of defense against insects and disease is good management during production. Planting resistant varieties, using irrigation practices that do not wet the leaves or flowers of plants, avoiding over-fertilization with nitrogen, and pruning during production to reduce canopy overgrowth can all serve to reduce produce decay before and after harvest. A second important defense is careful harvesting and preparation for market in the field. Thirdly, sorting out damaged or decaying produce will limit contamination of the remaining, healthy produce. Yet, even when the greatest care is taken, sometimes produce must be treated to control insects or decay-causing organisms.

While high humidity in the storage environment is important for maintenance of high quality produce, any free water on the surface of commodities can enhance germination and penetration by pathogens. When cold commodities are removed from storage and left at higher ambient temperatures, moisture from the surrounding warm air condenses on the colder product's surfaces. A temporary increase in ventilation rate (using a fan) or increasing exposure of the commodity to drier air can help to evaporate the condensed moisture and to reduce the chances of infection.

Control of storage insects in nuts and dried fruits and vegetables can be achieved by freezing, cold storage (less than 5 °C or 41 °F), heat treatments, or the exclusion of oxygen (0.5% or lower) using nitrogen. Packaging in insect-proof containers is needed to prevent subsequent insect infestation.

Some plant materials are useful as natural pesticides. Cassava leaves are known to protect harvested cassava roots from pests when used as packing material in boxes or bags during transport and short-term storage. The leaves are believed to release cyanogens, which are toxic to insects (Aiyer, 1978). The ashes of the leaves of *Lantana* spp. and *Ochroma logopur* have been found to be very effective when used as a dust against aphids attacking stored potatoes (CIP, 1982). The pesticidal properties of the seeds of the neem tree (as an oil or aqueous extract) are becoming more widely known and used throughout the world. Native to India, neem acts as a powerful pesticide on food crops but appears to be completely non-toxic to humans, mammals and beneficial insects (NRC, 1992). Any "natural pesticide" must be shown to be safe for humans before it is approved by regulatory authorities.

## Best Practices for Postharvest Pest Management

Consider the entire system (production, harvest, postharvest and marketing) when developing pest management strategies.

|             | <b>DO</b>   | <b>DO NOT</b>  |
|-------------|---|--|
| Pre-harvest | <p>Begin with cultivars offering some natural resistance to the pests you expect to have to deal with in your region.</p> <p>Plant only good quality, clean seed or stock.</p> <p>Use appropriate cultural practices during production to assist the produce to avoid and/or resist pest attack (proper planting density, fertilization, irrigation, pH modification, weeding, pruning, thinning, and ventilation/air movement through the canopy).</p> <p>Monitor fields/orchards to determine actual pest levels before implementing pest controls.</p> <p>Use a combination of appropriate pest control methods (biological control, chemical pesticides, protectants, sanitation practices).</p> <p>Eradicate diseased produce.</p> | <p>Allow fields and orchards to contain piles of debris and discarded produce.</p> |
| Harvest     | <p>Avoid damage during harvest by handling produce gently.</p> <p>Harvest at the proper maturity for produce to have the maximum resistance against pests.</p> <p>Use sharp, clean tools for harvest and trimming processes.</p>  |  |
| Curing      | <p>Cure root, tuber and bulb crops to heal harvest wounds and increase resistance to pests.</p>   |  |



|              | <b>DO</b>   | <b>DO NOT</b>  |
|--------------|---|--|
| Packinghouse | <p>Sort to remove any damaged, decayed, over-mature or under-ripe produce.</p> <p>Wash or clean produce to remove soil and debris and to reduce the amount of inoculum on surfaces.</p> <p>Trim senescent leaves from vegetables and remove dried flower parts from fruits.</p> <p>Use appropriate postharvest treatments to manage pest problems (chemicals, heat, hot water, pesticides).</p> |  |
| Packing      | Use ventilated plastic bags as liners for produce highly susceptible to water loss.   | Over-use liners that constrict air flow in the package and contribute to condensation (free moisture) and poor cooling efficiency. |
| Storage      | <p>Avoid ethylene damage to sensitive commodities by using ethylene scrubbers</p> <p>Keep produce at its lowest safe temperature for maximum pest management.</p> <p>Keep leafy vegetables, carrots, and cool season vegetables at very high relative humidity (98-100%) to reduce incidence of decay.</p> <p>Store onions and garlic at low humidity to reduce decay (60-70% RH).</p>          | <p>Mix lots of incompatible produce in storage.</p> <p>Keep sensitive commodities at chilling temperature</p>                      |

## Chemical Controls

Washing produce with chlorinated water can prevent decay caused by bacteria, mold and yeasts on the surface of produce. Calcium hypochlorite (powder) and sodium hypochlorite (liquid) are inexpensive and widely available. The effectiveness of the treatment will decrease if organic matter is allowed to build up in the wash water. The effectiveness of chlorine increases as pH is reduced from pH 11 to pH 8, but at lower pH chlorine becomes unstable.

Fruits and vegetables can be washed with hypochlorite solution (25 ppm available chlorine for two minutes) then rinsed to control bacterial decay. Alternatively, these commodities can be dipped in hypochlorite solution (50 to 70 ppm available chlorine) then rinsed with tap water for control of bacteria, yeasts and molds.

Source: Ogawa, J.M. and Manji, B.T. 1984. In: Moline, H.E. (ed). Postharvest Pathology of Fruits and Vegetables. University of California, Division of Agriculture and Natural Resources, UC Bulletin 1914.

| <b>Amounts of hypochlorite to add to clear, clean water for disinfection.</b> |                   |                         |                       |
|---|-------------------|-------------------------|-----------------------|
|   | <b>target ppm</b> | <b>ounces/5 gallons</b> | <b>cup/50 gallons</b> |
| <b>Sodium hypochlorite</b><br>(5.25%)   | 50                | .55                     | .5                    |
|   | 75                | .8                      | .75                   |
|   | 100               | 1.1                     | 1.0                   |
|   | 125               | 1.4                     | 1.25                  |
|   | 150               | 1.7                     | 1.5                   |
| <b>Sodium hypochlorite</b><br>(12.7%)   | 50                | .12                     | .1                    |
|   | 75                | .17                     | .15                   |
|   | 100               | .23                     | .2                    |
|   | 125               | .29                     | .25                   |
|   | 150               | .35                     | .3                    |

Source: Bachman, J. and Earles, R. 2000. Postharvest Handling of Fruits and Vegetables. Horticulture Technical Note. ATTRA.

For a list of registered pesticides in the USA, see the EPA Compendium of Registered Pesticides published by the U.S. Environmental Protection Agency (<http://epa.gov>)

**Sulfur:**

Sulfur is used on bananas as a paste (0.1 % active ingredient) to control crown rot fungi.

**Sulfur dioxide:**

SO<sub>2</sub> is used as a fumigant (with a 10 ppm residue tolerance) on grapes to control *Botrytis*, *Rhizopus* and *Aspergillus* fungi. Careful calculation of the amount of sulfur dioxide that is required to treat grapes can greatly reduce the need to vent or scrub the storage air after fumigation to remove excess SO<sub>2</sub>. For information on the "total utilization" fumigation technique that has been developed for treating grapes with sulfur dioxide, see Luvisi (1992).

**Sodium or potassium bisulfite:**

Bisulfites are usually contained within a paper or plastic pad that can be placed inside a carton to release SO<sub>2</sub> for control of molds on grapes during transportation and storage.

Sources: Luvisi, D.A. et al. 1992. Sulfur Dioxide Fumigation of Table Grapes. University of California, Division of Agriculture and Natural Resources, Bulletin 1932.

Ogawa, J.M. and Manji, B.T. 1984. In: Moline, H.E. (ed). Postharvest Pathology of Fruits and Vegetables. University of California, Division of Agriculture and Natural Resources, UC Bulletin 1914.

**Bicarbonate salts:**

Bicarbonate salts for postharvest decay prevention have been used on fresh peppers, melons, potatoes, carrots and citrus fruits. These salts are very inexpensive, safe to use, readily available, and accepted as “certified organic” and “chemical free” for marketing purposes.

**Bicarbonate salts include:**

Bicarbonate of soda, or “baking soda” (NaHCO<sub>3</sub>)

Potassium bicarbonate (KHCO<sub>3</sub>)

Application methods (with or without chlorination as desired):

| <b>Method</b>         | <b>Rate</b>  | <b>Followed by:</b> |
|-----------------------|--|---------------------|
| Overhead spray or dip | 2% solution<br>(use 2 g in 100ml water or 20g per liter)   |                     |
| Overhead spray or dip | 3% solution<br>(use 3 g in 100 ml water or 30 g per liter) | Rinse in water      |

Source: Smilanick, J. 2002. (Personal communication). Research Plant Pathologist, USDA ARS San Joaquin Valley Agricultural Sciences Center.

Bacterial soft rot (*Erwinia*) of cabbage can be controlled by using lime powder or a 15% solution of alum (15 g aluminum potassium sulfate in 100 mL of water). After treatment of the butt-end of the cabbage heads, the produce should be allowed to dry for 20 to 30 minutes before packing.

**Applying alum solution (spray or brush on):**

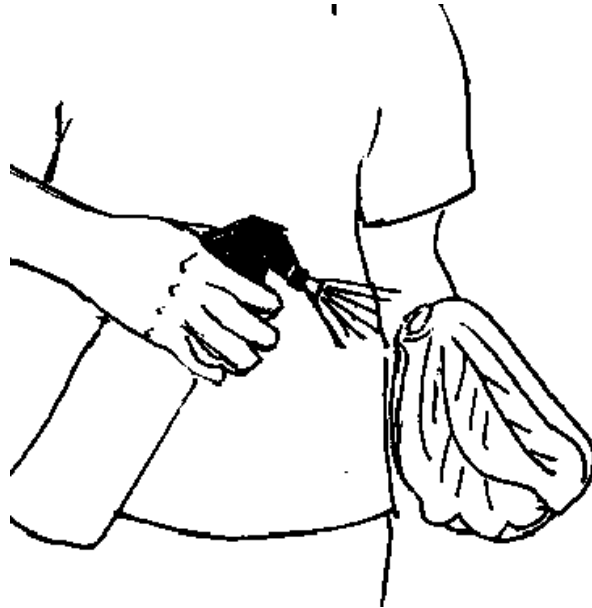

**Applying lime powder (press butt-end into powder):**

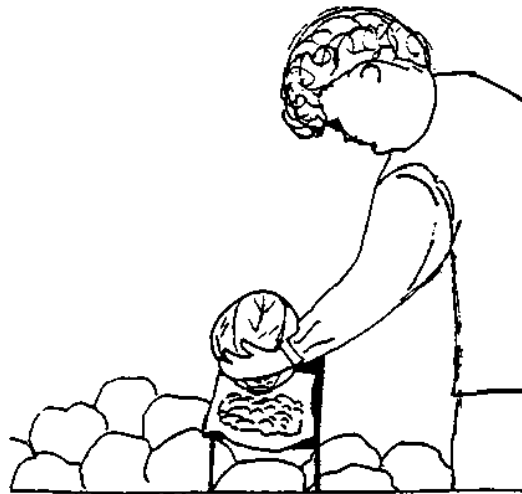

Source: Borromeo, E.S. and Ilag, L.L. 1984. Alum and Lime Applications: Potential Postharvest Control of Cabbage Soft Rot. *Appropriate Postharvest Technology* 1(1):10-12.

On occasions when fungicides must be applied to produce, a simple tray with holes punched in the bottom can be used hold the commodity while it is sprayed. In the illustration below, a hand-operated knapsack sprayer is used to spray fungicides on bananas to the stage of run-off. The bananas can then dry in the perforated tray before further handling.

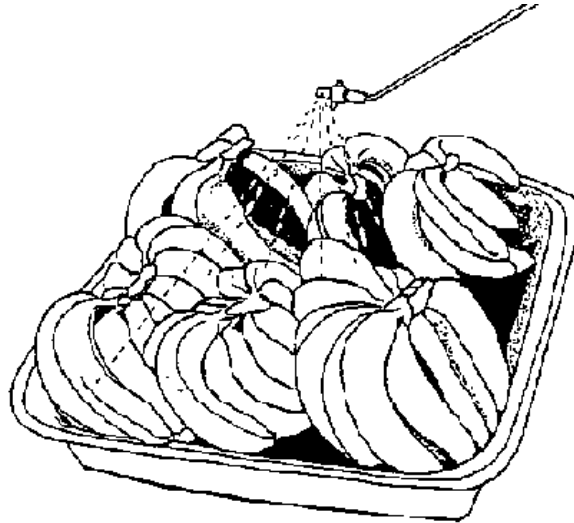

Source: FAO. 1989. Prevention of Postharvest Food Losses: Fruits, Vegetables and Root Crops. A Training Manual. Rome: UNFAO. p. 157.

A back-pack sprayer is a useful tool for applying fungicides and other postharvest chemical treatments. A wide variety of sizes and types of sprayers can be purchased at farm supply centers or from companies on the internet.



When fruit is packed for export, fungicides are often applied to meet the requirements of international quality standards and to reduce deterioration during transport. The "cascade applicator" illustrated below was developed to apply fungicide uniformly and effectively by using a liquid curtain to drench the fruit.

Fruit in a perforated plastic tray is introduced on a roller conveyor belt (not shown) into the applicator. Inside, a simple fan-shaped deflector creates a curtain of liquid fungicide. The fruit passes under the curtain where it is drenched, then out of the applicator to drain on a tilted return tray. The tank holds up to 50 L of fungicide solution, and a pump is mounted at the level of the tank outlet. A filter is fitted on the top of the tank to remove foreign matter from the return flow of fungicide in the applicator box and the return tray.

### Fungicide Applicator:

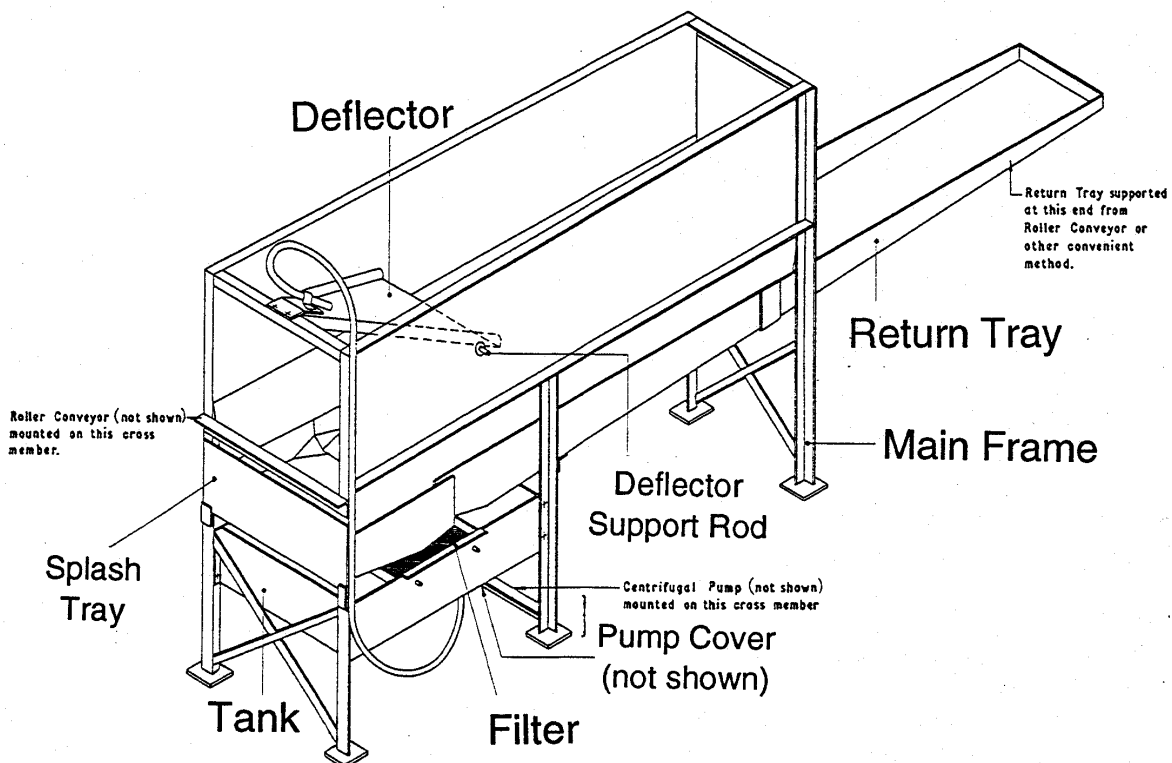

Source: Overseas Div., AFRC. 1974. National Institute of Agricultural Engineering. Bulletin No. 6. Silsoe, Bedfordshire, England.

## Vase Life of Cut Flowers

Some simple chemical treatments and handling practices can be used to prevent wilting and decay when handling and marketing fresh cut flowers, and can help cut flowers last much longer in the vase at home. If you are selling cut flowers, you could provide a printout listing some of these tips to your customers:

- Start with a clean bucket or vase (washed with hot soapy water and rinsed thoroughly).
- Gently remove lower leaves so there will be no leaves in the bucket or vase water.
- Re-cut the stems, removing one or two inches at an angle **under water**.

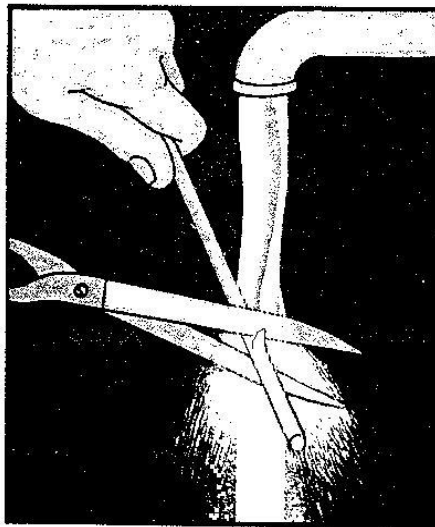

- Use de-mineralized water if the water in your area is “hard” (creates white deposits on faucets) or has been “softened” (full of salts).
- Use warm to hot water (40 °C or 100 °F).
- Use one of the following solutions. They contain acid to improve water flow, sugar to help buds open, and a preservative to reduce growth of fungi and bacteria.
  - 1) Mix 1 part lemon-lime soda with 3 parts warm water. Do not use diet sodas. Add ¼ teaspoon of household bleach per quart of water.
  - 2) Use 2 tablespoons of lemon juice or lemon juice concentrate, 1 tablespoon of sugar and ¼ teaspoon of bleach in a quart of warm water. Add another ¼ teaspoon of bleach to the vase every 4 days.
  - 3) Use a commercial floral preservative. These are inexpensive and convenient, but may not be as effective as the two recipes provided above.
- If you are using florist foam to arrange flowers, let it soak in the solution until it sinks on its own. Pushing it down into the vase will cause air bubbles to remain in the foam and can cause early flower death.

Source: Hesketh, K.A. et al. (n.d.). Extending the life of cut flowers in your home. University of California Cooperative Extension. DANR No. Publication 7169.



## Cold Treatments

Certain fungi and bacteria in their germination phase are susceptible to cold. Infections can be reduced by treating produce with a few days of storage at the coldest temperature the commodity can withstand without incurring damage (0 °C for apple, pear, grape, kiwifruit, persimmon and stone fruits). Adaskaveg stated that *Rhizopus stolonifer* and *Aspergillus niger* (black mold) can be killed when germinating for 2 or more days at 0°C (32 °F) (as cited in Kader, 2002), and pathogen growth can be nearly stopped by storage at temperatures below 5 °C (41 °F).

Cold treatments can also serve to control some insect pests, and are currently allowed for the control of fruit flies, the false codling moth, melon fly, pecan weevil, and lychee fruit borer. Treatment for control of fruit flies requires 10 days at 0 °C (32 °F) or below, or 14 days at 1.7 °C (35 °F) or below. Therefore, treatment is only suited to commodities capable of withstanding long-term, low-temperature storage such as apples, pears, grapes, kiwifruit and persimmons. Since requirements are subject to change, always refer to the latest edition of the APHIS treatment manual.

For produce packed before cold storage treatment, package vents should be screened to prevent the reinfestation by insects during handling.

### Cold Treatment Protocol for Mediterranean Fruit Fly (*Ceratitis capitata*)

| Temperature             | Exposure period (days) |
|-------------------------|------------------------|
| 0 °C (32 °F) or below   | 10                     |
| 0.6 °C (33 °F) or below | 11                     |
| 1.1 °C (34 °F) or below | 12                     |
| 1.7 °C (35 °F) or below | 14                     |
| 2.2 °C (36 °F) or below | 16                     |

Source: USDA APHIS PPQ Treatment Manual  
([www.aphis.usda.gov/ppq/manuals/online-manuals.htm](http://www.aphis.usda.gov/ppq/manuals/online-manuals.htm))

## Controlled/modified atmosphere treatments

For commodities that tolerate high CO<sub>2</sub> levels, 15 to 20% CO<sub>2</sub>-enriched air can be used as a fungistat to control decay-causing pathogens such as *Botrytis cinerea* on strawberry, blueberry, blackberry, fresh fig, and table grapes during transport. See page 97 for a description of the method for atmospheric modification within a pallet cover.

Insecticidal atmospheres (0.5% or lower O<sub>2</sub> and/or 40% or higher CO<sub>2</sub>) have been shown to be an effective substitute for methyl bromide fumigation to disinfest dried fruits, nuts, and vegetables. The effectiveness of insecticidal atmospheres depends upon the temperature, relative humidity, duration of exposure, and life stage of the insect. Low O<sub>2</sub> and/or high CO<sub>2</sub> have been used to kill certain insects in commodities that can tolerate these conditions. The first five of eight examples are from Mitcham et al. (1997):

1) The first and third instars of the greenheaded leafroller (*Planotortrix excessana*), the first and fifth instars of the brownheaded leafroller (*Ctenopseustis obliquana*), and the light brown apple moth (*Epiphyas postvittana*) are completely killed in 2 months when apples are stored at 0.5 °C in 3% O<sub>2</sub> and 3% CO<sub>2</sub>.

2) The eggs of the apple rust mite (*Aculus schlechtendali*) and the European red mite (*Panonychus ulmi*) are killed in 5.3 months when apples are stored at 2.8 °C in an atmosphere of 1% O<sub>2</sub> and 1% CO<sub>2</sub>.

3) Codling moth larvae (*Cydia pomonella*) are killed in 3 months when apples are stored at 0 °C, 1.5-2% O<sub>2</sub> and less than 1% CO<sub>2</sub>.

4) In kiwifruit, the adult two-spotted spider mite (*Tetranychus urticae*) is killed by 40 °C, 0.4% O<sub>2</sub> and 20% CO<sub>2</sub> in only 7 hours.

5) When persimmons are stored at 20 °C, 0.5% O<sub>2</sub> and 5% CO<sub>2</sub>, the third instar of leafrollers (*Planotortrix excessana*) is killed in 4 days. The larvae and adult mealy bug (*Pseudococcus longispinus*) are killed in 7 days.

Source: Mitcham, E.J., Zhou, S. and A.A. Kader. 1997. Potential for CA for postharvest insect control in fresh horticultural perishables: an update of summary tables compiled by Ke and Kader, 1992. p. 78-90. In Thompson, J.F. and Mitcham, E.J. (eds.) CA'97 Proceedings Volume 1: CA Technology and Disinfestation Studies. Department of Pomology Postharvest Hort Series No. 15.

6) Sweet potato weevil (*Cylas formicarius elegantulus*) has been controlled at ambient temperature in stored tropical sweet potatoes by treatment with low oxygen and high carbon dioxide atmospheres. At 25 °C (76 °F), storage in 2 to 4% oxygen and 40 to 60% carbon dioxide results in mortality of adult weevils in 2 to 7 days.

Source: Delate, K. et al. 1990. Controlled atmosphere treatments for control of sweet potato weevil in stored tropical sweet potatoes. *Journal of Economic Entomology* 83:461-465.

7) Codling moth (*Cydia pomonella*) in stone fruits can be controlled at 25 °C (76 °F) by using atmospheres of 0.5% O<sub>2</sub> and 10% CO<sub>2</sub> for 2 to 3 days (adult or egg) or 6 to 12 days (pupa). Normal color and firmness changes during ripening are not affected by treatment.

Source: Soderstrom, E.L. et al. 1990. Responses of codling moth life stages to high carbon dioxide or low oxygen atmospheres. *Journal of Economic Entomology* 83:472-475.

8) Treatments with 45% CO<sub>2</sub> at 0°C (32°F) are being developed for several surface pests, including omnivorous leafroller (*Platynota sultana*), western flower thrips (*Frankliniella occidentalis*), and Pacific spider mite (*Tetranychus pacificus*) on harvested table grapes. This treatment requires 13 days at 0 to 2 °C (32 to 36°F) and could be conducted in a marine container during transport. However, neither this nor other insecticidal CA treatments are approved yet as quarantine treatments.

Source: Mitcham, E.J., Mitchell, F.G., Arpaia, M.L. and A.A. Kader. 2002. Postharvest Treatments for insect control. p. 251-257. In: A.A. Kader (ed.). Postharvest Technology of Horticultural Crops, Third Edition. University of California, ANR Publication 3311.

## Heat Treatments

Hot water dips or heated air can be used for direct control of postharvest insects. In mangoes, an effective treatment is 46.4 °C for 65 to 90 minutes, depending on fruit size, variety and country of origin (Mitcham et al. in Kader, 2002). Fruit should not be handled immediately after heat treatment. Whenever heat is used with fresh produce, cool water showers or forced cold air should be provided to help return the fruits to their optimum temperature as soon as possible after completion of the treatment.

Some pathogens are susceptible to heat treatments. Brief hot water dips or forced-air heating can be effective for disease control, especially for reducing the microbial load for crops such as plums, peaches, papaya, cantaloupe and stone fruits, sweet potatoes, and tomatoes (Shewfelt, 1986).

| Hot Water Treatments |  |                  |            |                      |
|----------------------|--|------------------|------------|----------------------|
| Commodity            | Pathogens  | Temperature (°C) | Time (min) | Possible injuries    |
| Apple                | <i>Gloeosporium sp.</i><br><i>Penicillium expansum</i>                 | 45               | 10         | Reduced storage life |
| Grapefruit           | <i>Phytophthora citrophthora</i>                                       | 48               | 3          |                      |
| Green Beans          | <i>Pythium butleri</i><br><i>Sclerotinia sclerotiorum</i>              | 52               | 0.5        |                      |
| Lemon                | <i>Penicillium digitatum</i><br><i>Phytophthora sp.</i>                | 52               | 5-10       |                      |
| Mango                | Anthracnose <i>Collectotrichum gloeosporioides</i>                     | 52               | 5          | No stem rot control  |
| Melon                | Fungi  | 57-63            | 0.5        |                      |
| Orange               | <i>Diplodia sp.</i><br><i>Phomopsis sp.</i><br><i>Phytophthora sp.</i> | 53               | 5          | Poor de-greening     |
| Papaya               | Fungi  | 48               | 20         |                      |
| Papaya*              | Anthracnose <i>Colletotrichum gloeosporioides</i>                      | 42<br>49         | 30<br>20   |                      |
| Peach                | <i>Monolinia fruticola</i><br><i>Rhizopus stolonifer</i>               | 52               | 2.5        | Motile skin          |
| Pepper (bell)        | <i>Erwinia sp.</i>   | 53               | 1.5        | Slight spotting      |

\* papaya anthracnose control requires both treatments, 30 min at 42 °C followed by 20 min at 49 °C.

| <b>Hot Forced-Air Treatments</b> |  |                         |                   |               |                          |
|----------------------------------|--|-------------------------|-------------------|---------------|--------------------------|
| <b>Commodity</b>                 | <b>Pathogens</b>   | <b>Temperature (°C)</b> | <b>Time (min)</b> | <b>RH (%)</b> | <b>Possible injuries</b> |
| Apple                            | <i>Gloeosporium sp.</i><br><i>Penicillium expansum</i>   | 45                      | 15                | 100           | Deterioration            |
| Melon                            | Fungi  | 30-60                   | 35                | low           | Marked breakdown         |
| Peach                            | <i>Monolinia fruticola</i><br><i>Rhizopus stolonifer</i>   | 54                      | 15                | 80            |                          |
| Strawberry                       | <i>Alternaria sp.</i><br><i>Botrytis sp.</i> ,<br><i>Rhizopus sp.</i><br><i>Cladosporium sp.</i> | 43                      | 30                | 98            |                          |

Sources: Barkai-Golan, R. and Phillips, D.J. 1991. Postharvest treatments of fresh fruits and vegetables for decay control. Plant Disease. 75:1085-1089. USDA Handbook 66. 2004 <http://www.ba.ars.usda.gov/hb66/contents.html>

## Biological Control and Plant Growth Regulators

Two biological control products (antagonistic organisms) are currently used as complementary tools (to chemical and/or heat treatments) for the management of postharvest decays with other strategies as part of an integrated pest management program for a few fruits and vegetables (see table below). Two plant growth regulators can be used to delay senescence of citrus fruits and consequently delay their susceptibility to decay (see table below).

Commercially available biological control materials and plant growth regulators (PGR) registered as postharvest treatments:

| Category   | Organism/<br>Product                     | Year<br>introduced | Crop             | Decay organisms<br>or function   | Methods of<br>application  | Residue<br>tolerance (ppm) |
|------------|--|--------------------|------------------|--|----------------------------|----------------------------|
| Biocontrol | <i>Pseudomonas syringae</i><br>Bio-Save) | 1995               | Citrus           | <i>Penicillium digitatus</i> ,<br><i>P. italicum</i> ,<br><i>Geotrichum citri-aurantii</i> | Dip or spray               | exempt                     |
|            |  |                    | Cherries         | <i>Penicillium expansum</i> ,<br><i>Botrytis cinerea</i>                                   | Drench                     | exempt                     |
|            |  |                    | Apples,<br>pears | <i>Penicillium expansum</i> ,<br><i>Botrytis cinerea</i> , <i>Mucor piriformis</i>         | Dip or drench              | exempt                     |
|            |  |                    | Potatoes         | <i>Fusarium sambucinum</i> ,<br><i>Helminthosporium solani</i>                             | Dip or spray               | exempt                     |
| Biocontrol | <i>Candida oleophila</i><br>(Aspire)     | 1995               | Pome<br>fruits   | Decay pathogens  | Any type of<br>application | exempt                     |
|            |  |                    | Citrus           | Decay pathogens  | Any type of<br>application | exempt                     |
| PGR        | Gibberellic<br>acid (Pro Gibb)           | 1955               | Citrus           | Delays senescence<br>(delays onset of decay)   | Storage wax                | exempt                     |
| PGR        | 2,4-D (Citrus Fix)                       | 1942               | Citrus           | Delays senescence<br>of buttons (delays<br>onset of decay)                                 | Storage wax                | 5                          |

Source: Adaskaveg, J.E., Forster, H. and N.F. Sommer. 2002. Principles of postharvest pathology and management of decays of edible horticultural crops. p. 196-195. In: A.A. Kader (ed.). Postharvest technology of horticultural crops, third edition. University of California, ANR Publication 3311.

## **Chapter 6: Temperature and Relative Humidity Control**

Temperature and relative humidity management are sometimes referred to as "Maintaining the Cold Chain" during postharvest handling and marketing. Produce should always be cooled as soon as possible after harvest to protect quality, reduce weight loss and extend shelf life. Fresh fruits and vegetables are living tissues separated from the parent plant, which supplied them with water via transpiration. Once harvested, the water supply is cut off, and produce gains heat through respiration and conduction from the surrounding environment. For the highly perishable commodity strawberries, each one hour delay in cooling results in a 10% increase in decay at destination.

Produce exposed to the sun after harvest gains an enormous amount of heat and will have reduced shelf life. Tomatoes left in the sun for one hour after harvest will be at least 15 °C (25 °F) hotter than fruit held in the shade. And produce left at ambient, dry conditions will lose moisture up to 100 times faster than produce that is moved into a cold room (FAO, 1986).

| <b>Temperature effects on rate of water loss:</b> |                                      |                                     |
|---|--------------------------------------|-------------------------------------|
| <b>Temperature (°C)</b>                           | <b>Theoretical shelf life (days)</b> | <b>% Weight loss (= water loss)</b> |
| 0   | 100                                  | 1                                   |
| 10  | 45                                   | 3                                   |
| 20  | 20                                   | 6                                   |
| 30  | 10                                   | 12                                  |
| 40  | 4                                    | 25                                  |

Sources: USDA Handbook 66 (2004), FAO 1986

Throughout the period between harvest and consumption, temperature control has been found to be the most important factor in maintaining product quality. Fruits, vegetables and cut flowers are living, respiring tissues separated from their parent plant. Keeping products at their lowest safe temperature (0 °C or 32 °F for temperate crops or 10-12 °C or 50-54 °F for chilling sensitive crops) will increase storage life by lowering respiration rate, decreasing sensitivity to ethylene gas and reducing water loss. Reducing the rate of water loss slows the rate of shriveling and wilting, which are causes of serious postharvest losses.

Keeping products too cool can also be a serious problem. It is important to avoid chilling injury with symptoms such as failure to ripen (bananas and tomatoes), development of pits or sunken areas (oranges, melons and cucumbers), brown discoloration (avocados, cherimoyas, eggplant), increased susceptibility to decay (cucumbers and beans), and development of off-flavors (tomatoes) (Shewfelt, 1990).

Cooling involves heat transfer from produce to a cooling medium such as a source of refrigeration. Heat transfer processes include conduction, convection, radiation and evaporation. If a steady supply of electricity is available, mechanical refrigeration systems provide the most reliable source of cold. One ton of refrigeration capacity requires about one horsepower of compressor capacity. Fans use about 33% of the energy required for cooling, so don't install fans that are larger than necessary.

Cooling Methods include room cooling, forced-air cooling and evaporative cooling. A variety of portable forced-air coolers have been designed for use by small-scale growers and handlers (Talbot and Fletcher, 1993; Rij et al., 1979; Parsons and Kasmire, 1974). However, a variety of simple methods exist for cooling produce where electricity is unavailable or too expensive. Some examples of alternative systems (from Thompson in Kader, 1992) include night air ventilation, radiant cooling, evaporative cooling, the use of ice and underground (root cellars, field clamps, caves) or high altitude storage. Ice can be manufactured using simple solar cooling systems, where flat plate solar collectors are used to generate power to make ice, which is then used to cool produce (Umar, 1998). Ice can be used either directly as package ice, to cool water for use in a hydro-cooler, or as an ice bank for a small forced-air or room cooling system.

Several simple practices are useful for cooling and enhancing storage system efficiency wherever they are used, and especially in developing countries where energy availability may be limited and any savings may be critical. Shade should be provided over harvested produce, over packing areas, for buildings used for cooling and storage, and for transport vehicles. Using shade wherever possible will help to reduce the temperatures of incoming produce and subsequent cooling costs. Trees are a fine source of shade and can reduce ambient temperatures around packinghouses and storage areas. Light colors on buildings will reflect light (and heat) and reduce heat load. Sometimes spending money will save money, especially when purchasing lighting equipment. High pressure sodium lights and LEDs produce less heat and use less energy than incandescent bulbs. Two recent publications on pre-cooling and energy use in horticulture provide illustrations and information on costs and benefits of using cooling at the farm level (Kitinoja and Thompson, 2009; Winrock International, 2010).

Another aspect to consider when handling fruits and vegetables is the relative humidity of the storage environment. Loss of water from produce is often associated with a loss of quality as visual changes, such as wilting or shriveling and textural changes, can take place. If using mechanical refrigeration for cooling, the larger the area of refrigerator coils, the higher the relative humidity in the cold room will remain. It pays, however, to remember that water loss may not always be undesirable, for example, if produce is destined for dehydration or canning.



For fresh market produce, any method of increasing the relative humidity of the storage environment or decreasing the vapor pressure deficit (VPD) between the commodity and its environment will slow the rate of water loss. The best method of increasing relative humidity is to reduce temperature. Another method is to add moisture to the air around the commodity using mists, sprays, or, as a last resort, by wetting the store room floor. Another way is to use vapor barriers such as waxes, polyethylene liners in boxes, coated boxes, or a variety of inexpensive and recyclable packaging materials. Any added packaging materials will increase the difficulty of efficient cooling, so vented liners (about 5% of the total area of the liner) are recommended. The liner vents must line up with the package vents to facilitate cooling of the produce inside. Vented liners will decrease VPD without seriously interfering with oxygen, carbon dioxide and ethylene movement.

## Temperature Management

During the period between harvest and consumption, temperature control is the most important factor in maintaining product quality. Keeping fruits cool will slow down the changes associated with ripening, and give you more time to market your produce. Generally, for each hour of delay between harvest and cooling, one day of shelf life is lost (Cantwell, 1998). Shivel symptoms in green beans indicate that the beans have lost an enormous amount of their saleable weight. If you can see just a trace of shivel in French beans, more than 30% of their original weight has been lost!

## Best practices for managing temperature and relative humidity

| DO  | DO NOT  |
|---|---|
| Cool produce as soon as possible after harvest.   |   |
| Cool using appropriate methods for each commodity (consider water tolerance, time required to reach 7/8ths cooling, and susceptibility to desiccation). | Hydro-cool crops that are easily damaged (apricots or fresh herbs). |
| Shade should be provided over harvested produce, over packing areas, for buildings used for cooling and storage, and for transport vehicles.            |   |
| Trees are a fine source of shade and can reduce ambient temperatures around packinghouses and storage areas.  |   |
| Light colors on buildings will reflect light (and heat) and reduce heat load. Design buildings with overhangs on the sunny side to provide shade.       |   |
| High pressure sodium lights in packing and cooling facilities will produce less heat and use less energy than incandescent bulbs.                       |   |
| The best method to reduce water loss is to increase RH by reducing temperature.   |   |

| <b>DO</b>  | <b>DO NOT</b>  |
|--|--|
| Wet the floor of storage rooms to increase the RH inside the room.   | Wet the floors when storing onions or garlic.  |
| Monitor storage rooms by measuring temperature in several locations (in packages, at edges of stacks, near vents, doors and cooling ducts). Re-arrange produce or adjust air flow to avoid too-warm and/or too-cold spots. |  |
| Use proper containers suited to the method used for cooling (waxed cartons or wooden boxes for hydro-cooling or icing, boxes with aligned side vents for forced-air cooling).  |  |
| Consider using forced-air coolers inside a cold room to speed cooling and decrease water loss and decay rate.  |  |
| Monitor hydro-cooler water quality and clean and sanitize the cooler each day before use.  |  |
| Cool before loading produce into refrigerated trucks (these trailers are designed only to maintain cool temperatures).   |  |
| Use high quality insulation in coolers, storage rooms and transport vehicles to reduce incoming environmental heat load.   |  |
| Use plastic strip curtains on doorways to prevent warm air from entering coolers or refrigerated trucks.   |  |
| Mist water-tolerant vegetables during handling, storage and marketing to decrease the rate of water loss.  |  |
| Be careful when using specialty packaging since these are even more sensitive to temperature abuse.  | <p>Use SO<sub>2</sub> pads if temperature is not well controlled; increased rate of SO<sub>2</sub> release can bleach table grapes</p> <p>Use MAP if temperature is not well controlled; MAP can become out of control, and the faster increase in CO<sub>2</sub> and rapid decrease in O<sub>2</sub> damages produce.</p> |

**WATER LOSS = LOSS of SALEABLE WEIGHT = LOSS of MONEY**

## Room Cooling

Room cooling is a relatively low cost but very slow method of cooling when electricity for mechanical refrigeration is available. When using room cooling, produce is simply loaded into a cold room, and cold air is allowed to circulate among the cartons, sacks, bins, or bulk load. This cooling method is best suited for less perishable commodities, such as potatoes, onions, apples, sweet potatoes, and citrus fruits, since more highly perishable crops will deteriorate too much before being adequately cooled. Room cooling may be all you need if you chill sensitive crops that need to be cooled from early-morning harvest temperatures to storage temperatures of 10 to 13 °C (50-55 °F). The design and operation of cold rooms are fairly simple and no special equipment is required.

It is important to leave adequate space between stacks of boxes inside the refrigerated room in order for produce to cool quicker. About 1 inch (2.5 cm) is sufficient to allow cold air to circulate around individual boxes. Produce in vented boxes will cool much faster than produce packed in un-vented containers. In many small-scale cold rooms, produce has been loaded into the room so tight that cooling cannot take place at all. And despite the high cost of running the refrigeration system, the produce temperature never decreases to recommended levels.

Stacks of produce inside the cold room should be narrow, about one pallet width in depth (two or three cartons). Fans should be installed to move the cold air throughout the room. Air circulating through the room passes over surfaces and through any open space, so cooling from the outside to the center of the stacks is mostly from conduction. You will want to monitor the temperature of the produce within the packages at various locations in the room to determine if produce is being cooled as desired. Rearrange the stacks and measure the rate of cooling until you find the right pattern for your cold room.

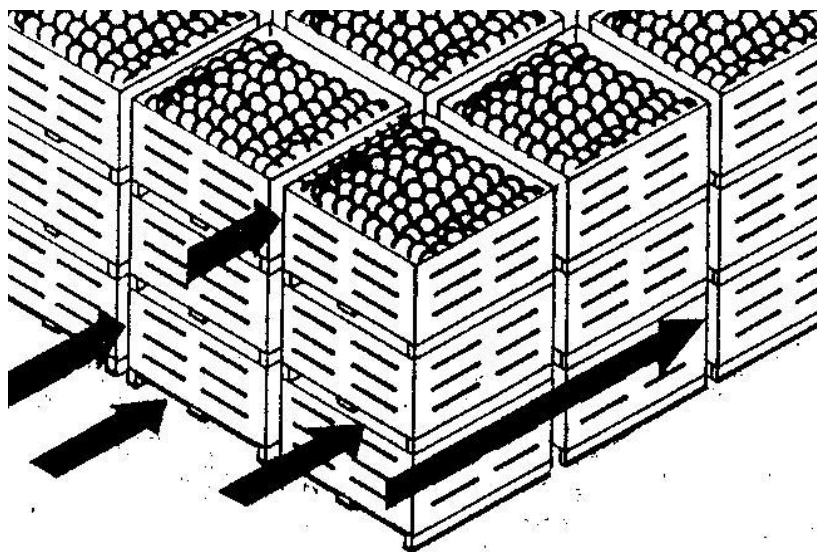

## Forced-air Cooling (See also the USDA Portacooler on page 202)

Forced-air cooling pulls or pushes air through the storage containers themselves, greatly speeding the cooling rate of any type of produce. Many types of forced-air coolers can be designed to move cold, moist air over the commodities.

Illustrated below is a view of a cold wall forced-air cooler. The canvas sheets must be well sealed and the pallet opening blocked for the tunnel-style cooler to function properly.

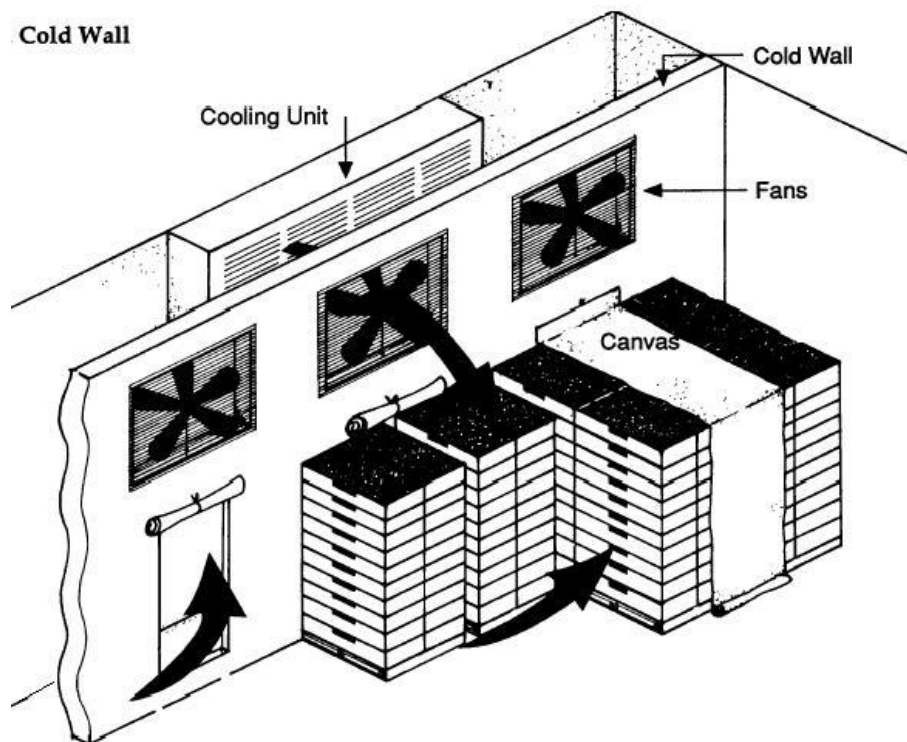

Source: Gast, K.L.B. and Flores, R. 1991. Precooling Produce. Kansas State University Cooperative Extension, Manhattan, Kansas.

A portable forced-air cooler can be constructed using a canvas or polyethylene sheet. The sheet is rolled over the top and down the back of the boxes to the floor, sealing off the unit and forcing air to be pulled through the vents (vent area should be at least 5% of the surface area of the carton) of the cartons stacked against the cooler. This unit is designed to be used inside a refrigerated storage room. The fan unit is shown detached to illustrate how the air should flow within the cooler. For best results and minimum cost of operation, the warm exhaust air from the fan should be directed toward the return air inside the cold room.

**A portable forced-air cooler:**

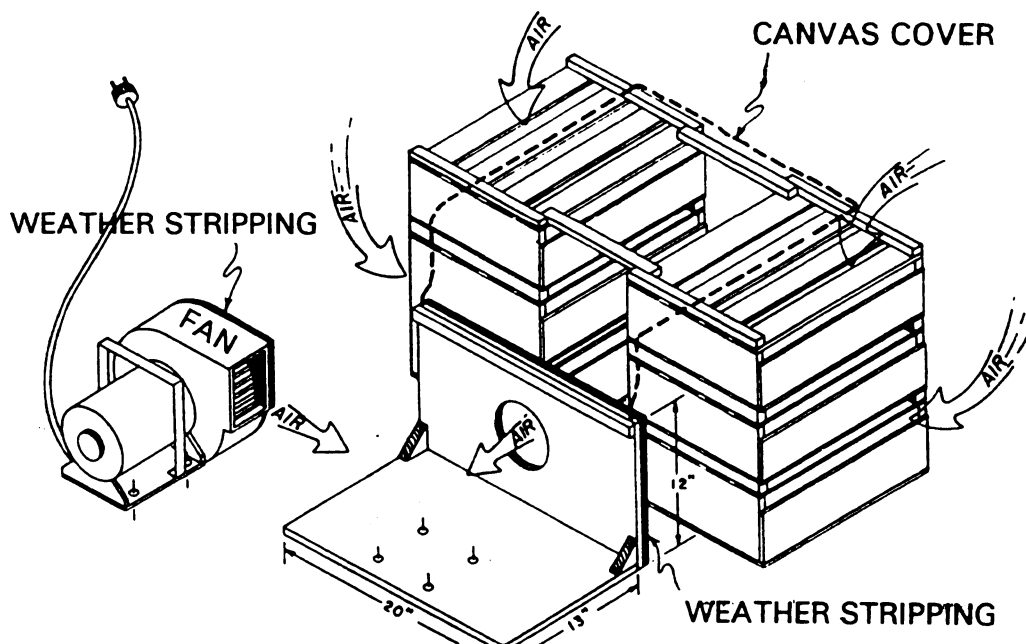

Source: Parsons, R.A. and Kasmire, R.F. 1974. Forced-air unit to rapidly cool small lots of packaged produce. University of California Cooperative Extension, OSA #272.

**A simple forced air cooler:**



Photo: L. Kitinoja, Indonesia.

The illustrations below show two types of forced-air coolers used for cooling cut flowers. Each is equipped with a fan to pull air from the cold room through the boxed produce.

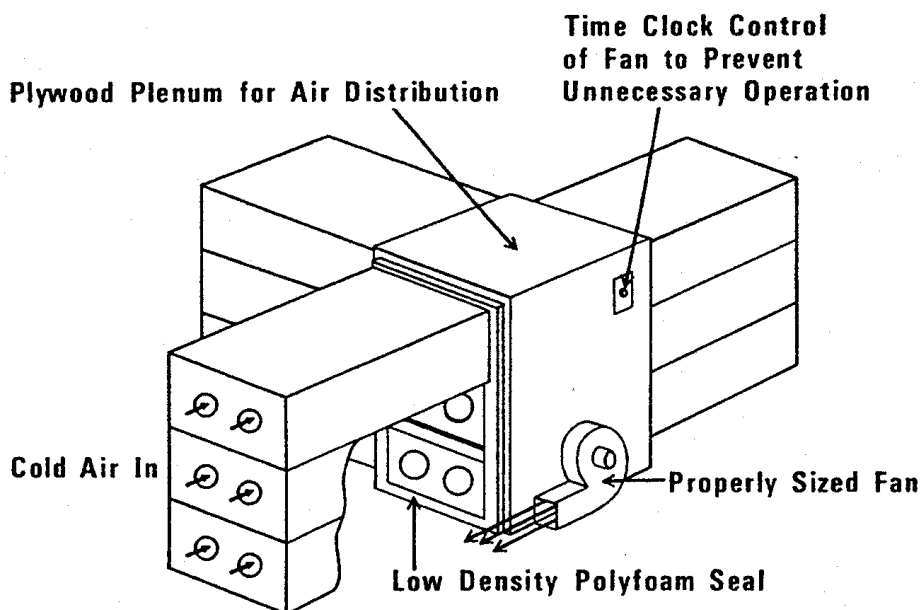
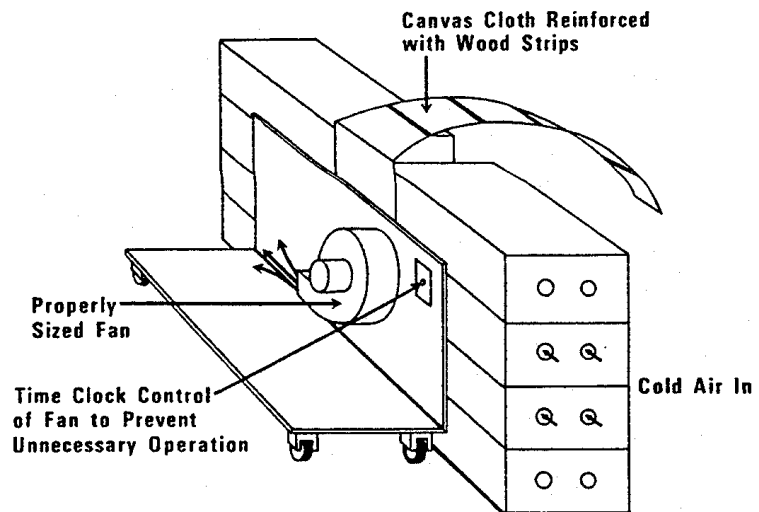

Source: Rij, R. et al. 1979. Handling, Precooling and Temperature Management of Cut Flower Crops for Truck Transportation. USDA Science and Education Administration, UC Leaflet 21058.

The illustrations below show the recommended pattern of vents for cartons used to hold produce that is to be forced-air cooled. Vents should make up 5% of the total surface area, and should be located 5 to 7.5 cm (2 to 3 inches) away from the corners. A few large vents (1.3 cm = 0.5 inch wide or more) are better than many small vents.

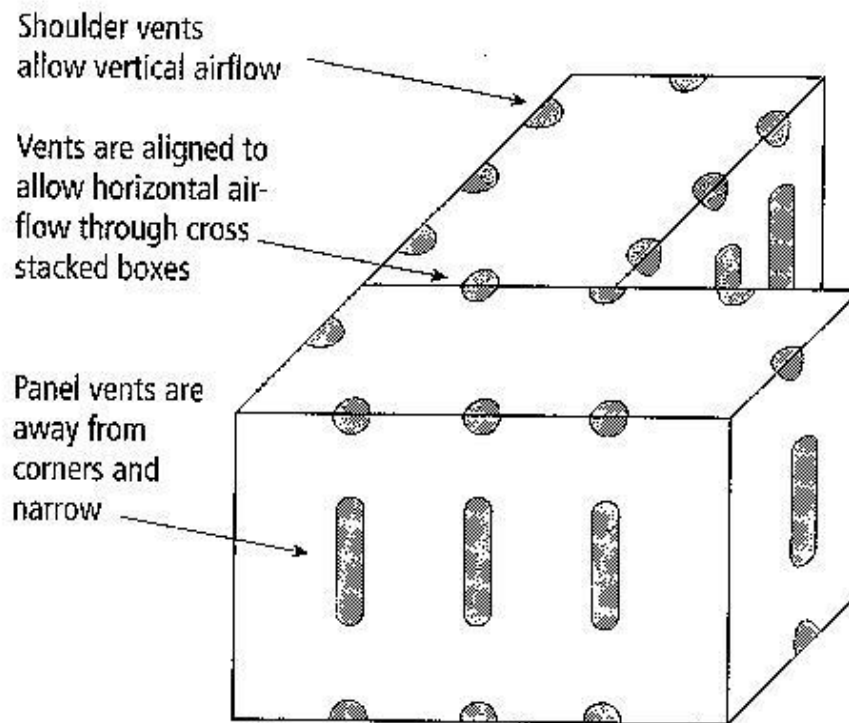

Sources: Thompson, J.F. 2002. Cooling horticultural commodities. p.97-112. In: Kader, A.A. (ed.). Postharvest Technology of Horticultural Crops. Univ. of California, Div. of Agriculture and Natural Resources, Publication 3311.

Mitchell, F.G. et al. 1972. Commercial cooling of fruits and vegetables. California Agricultural Experiment Station Extension Service, Manual 43.

## Hydro-cooling

Hydro-cooling provides fast, uniform cooling for some commodities. The commodity as well as its packaging materials must be tolerant of wetting, chlorine (used to sanitize the hydro-cooling water) and water-beating damage (Mitchell in Kader, 1992).

The simplest version of a hydro-cooler is a tank of cold water in which produce is immersed. The hydro-cooler, shown below, showers produce with icy water as the loose produce moves along a conveyor.

### In-line hydro-cooling shower:

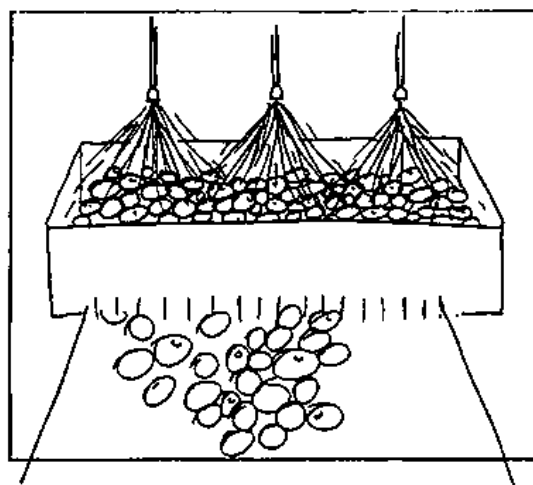

A batch-type hydro-cooler can be constructed to hold entire pallet-loads of produce (Thompson in Kader, 2002). Conveyors can be added to help control the amount of time the bins of produce stay in contact with the cold water.

### Batch-type hydro-cooling shower:

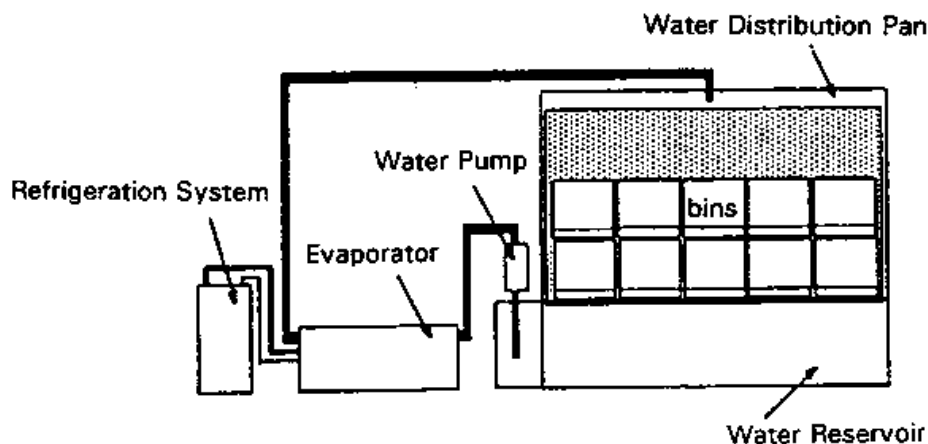



## Hydro-cooler Use and Maintenance

Water is recirculated in hydro-coolers and should be chlorinated with 100 to 150 ppm of available chlorine (60 mL per 40 L or 2 ounces of chlorine bleach per 10 gallons of water) to prevent the spread of decay. Several times during use each day, test for available chlorine using a chemical test kit and adjust as necessary. Organic matter ties up chlorine, so if the produce is especially dirty you will use more chlorine than usual. Washing produce before hydro-cooling will decrease this problem.

Keep the pH of the water in the range of 6.5 to 7.5 to prevent corrosion problems and the release of toxic chlorine gas. Use litmus paper strips or an inexpensive electronic pH meter to measure pH, and add muriatic acid to decrease pH or lye to increase pH (be sure to follow directions on the labels of these products). At the end of each day the entire cooler should be drained and cleaned. Waste water may contain pesticide residues and chlorine, so follow local regulations on proper disposal methods.

About 25% of the energy used to run a hydro-cooler is required to remove heat conducted across exterior surfaces and pipes from the air. Another 10% is used to offset the heating caused by the water pump. Insulating the hydro-cooler and keeping it in a cool location (inside a cold room or, at the minimum, in deep shade) will decrease the cost of operation. Starting with cooler produce (harvested in the early morning, kept in the shade during sorting and packing, using naturally cool well water to pre-rinse warm produce) will also decrease costs by reducing cooling times.

### To reduce hydro-cooler costs:

- Insulate the hydro-cooler
- Set it up in deep shade or inside a cold room
- Start with produce harvested in the cooler morning hours

## Evaporative Cooling

These packinghouses are made from natural materials that can be moistened with water. Wetting the walls and roof first thing in the morning creates conditions for evaporative cooling of a packinghouse that is made from straw.

### Straw packinghouse:

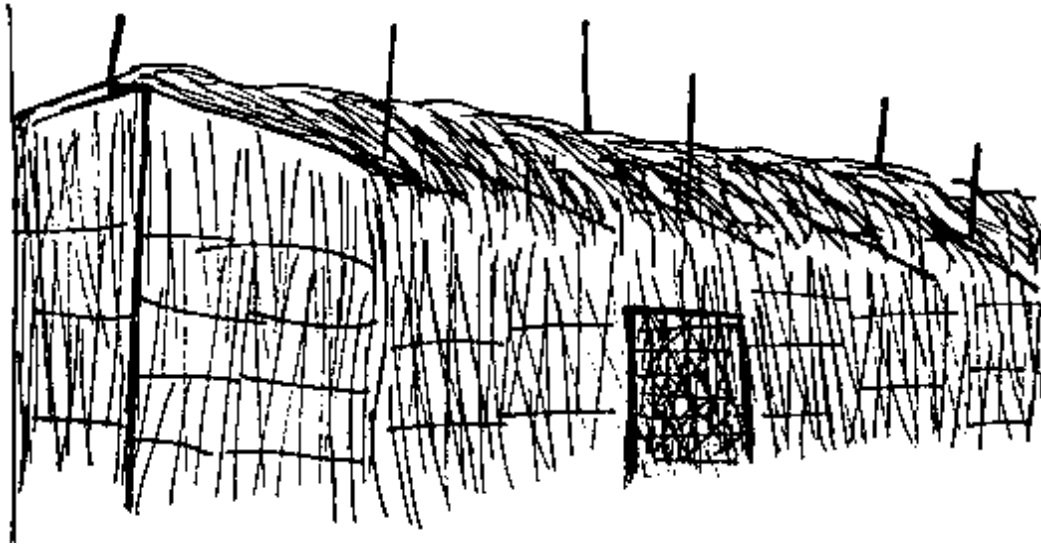

The packinghouse illustrated below is made with walls of wire mesh that hold charcoal. By moistening the charcoal with water each morning, the structure will evaporatively cool during the day.

### Straw packinghouse:

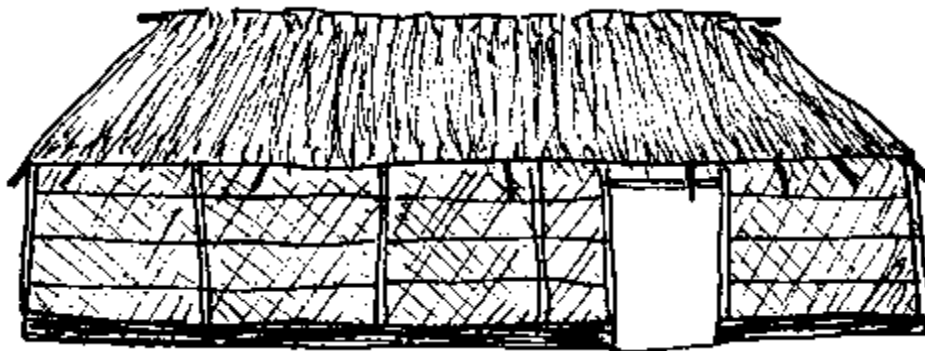

Source: FAO. 1986. Improvement of Post-Harvest Fresh Fruits and Vegetables Handling- A Manual. Bangkok: UNFAO Regional Office for Asia and the Pacific.

Evaporative coolers can be constructed to cool the air in an entire storage structure or just a few containers of produce. These coolers are best suited for lower humidity regions, since the degree of cooling is limited to 1 to 2 °C (2 to 4 °F) above the wet-bulb temperature. A cooling pad of wood fiber or straw is moistened, and air is pulled through the pad using a small fan. In the example provided here, 0.5 gallon of water per minute is dripped onto an 8 square-foot pad, providing enough moist air to cool up to 18 crates of produce in 1 to 2 hours. Water is collected in a tray at the base of the unit and re-circulated.

An evaporative cooler can be combined with a forced-air cooler for small lots of produce. Air is cooled by passing through the wet pad before it passes through the packages and around the produce. The air can be cooled within a few degrees of the wet-bulb temperature of ambient air.

#### Evaporative forced-air cooler:

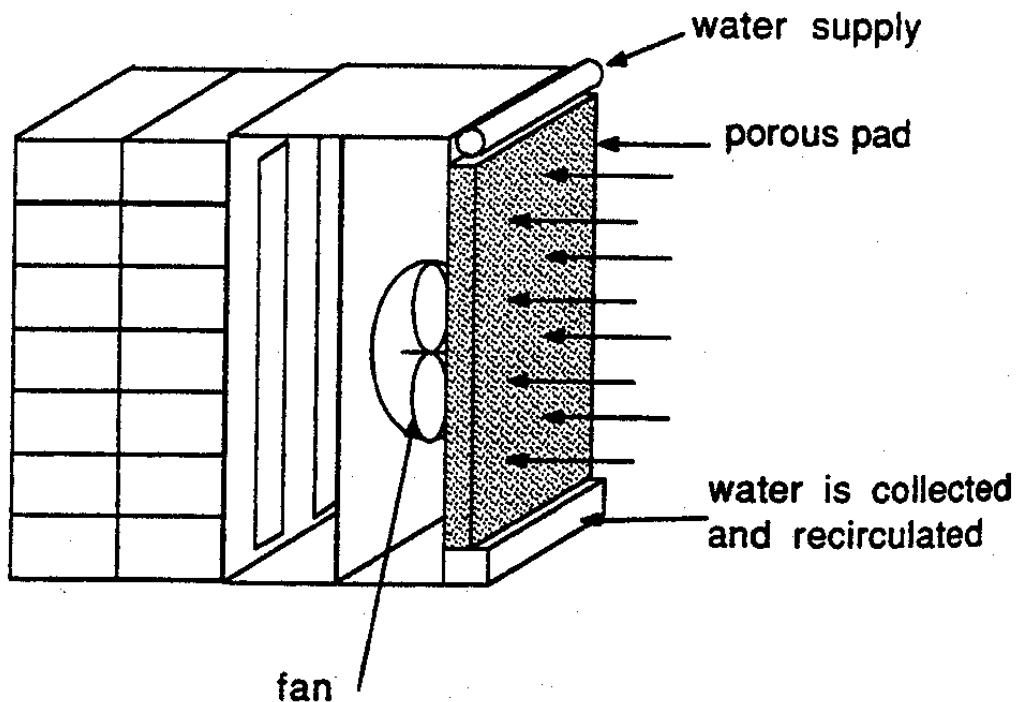

Source: Thompson, J. F. and Kasmire, R.F. 1981. An evaporative cooler for vegetable crops. California Agriculture, March-April: 20-21.

Source: Mitchell in Kader, 1992. Postharvest Technology of Horticultural Crops. University of California, Division of Agriculture and Natural Resources, Publication 3311. p. 296.

The evaporative cooler shown below is equipped with a vortex wind machine. Chicken wire was used to construct two thin boxes on opposite sides of the cooler that hold wet chunks of charcoal or straw. Water is dripped onto the charcoal or straw, and the wind turns the turbine, sucking moist, cool air through the load of produce inside the cooler. When using this cooler, temperatures are reduced to 3 to 5 °C (6 to 10 °F) below ambient air temperature, while relative humidity is about 85 %.

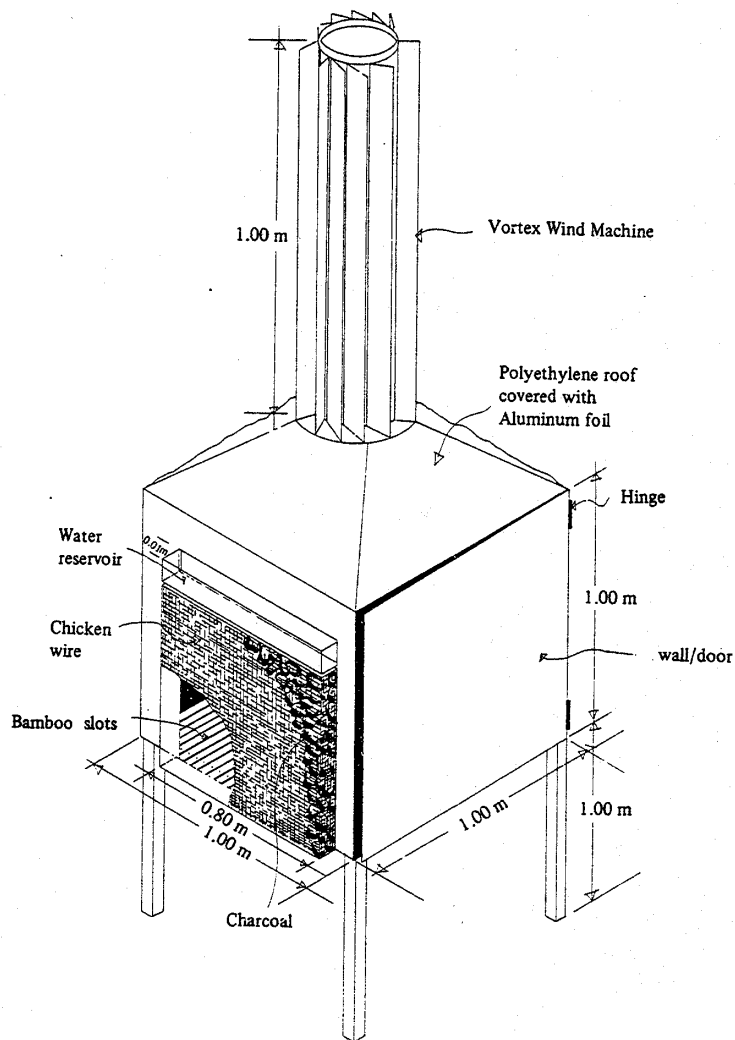

Source: Redulla, C.A. et al. 1984. Temperature and relative humidity in two types of evaporative coolers. *Postharvest Research Notes*, 1(1): 25-28.

Evaporative coolers can be constructed from simple materials, such as burlap and bamboo. The "drip cooler" shown operates solely through the process of evaporation without the use of a fan. Cooling will be enhanced if the unit is kept shaded and used in a well-ventilated area.

**Drip cooler:**

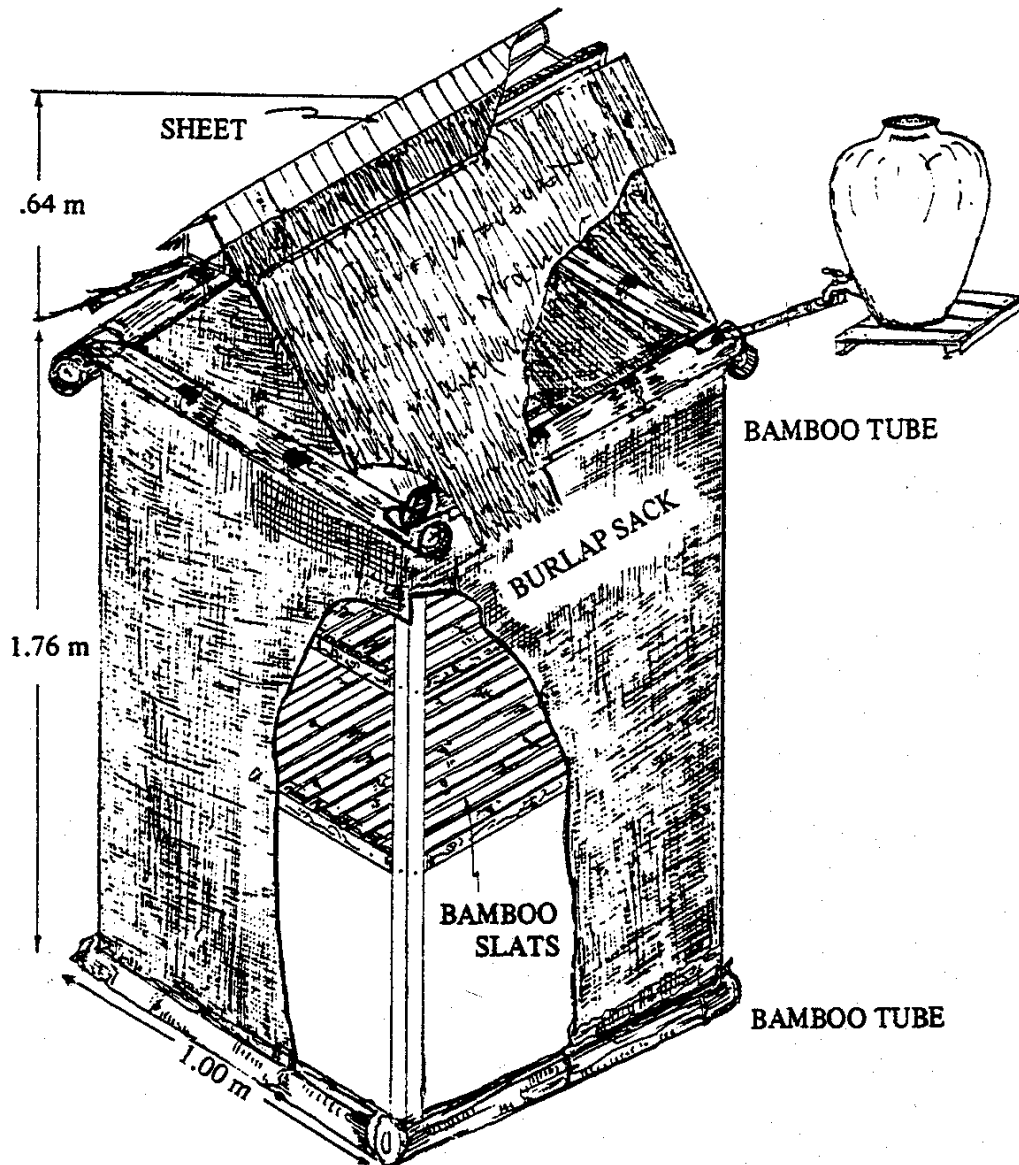

Source: Redulla, C.A. et al. 1984. Keeping perishables without refrigeration: use of a drip cooler. *Appropriate Postharvest Technology*, 1(2): 13-15.

Two simple evaporative coolers have been developed and used in the Philippines for cooling and storage of vegetables (such as tomatoes, sweet peppers and mustard greens). Type a, illustrated below, is standing in a galvanized iron (GI) pan of water, and has another pan of water on top. The sides and top are covered with jute sacks that are kept wet by dipping their top and bottom edges into the pans of water. In type b, the inner side walls are constructed from plain GI sheet with fine holes (spaced at 5 x 5 cm) while the outer walls are made of fine mesh (0.32 cm) wire. The 1.5 cm space between the inner and outer walls is filled with rice hulls, which are kept wet by a cloth that is dipped into a pan of water placed on top of the cooler.

Produce stored in these coolers has a longer shelf life than produce kept in ambient conditions. Tomatoes and peppers lost less weight and ripened more slowly, and could be kept for as long as they typically can be stored under refrigeration (about 3 weeks). Decay can be a problem, but it can be controlled by washing in chlorinated water prior to cooling. Mustard greens lost much less weight and showed little wilting for up to 5 days.

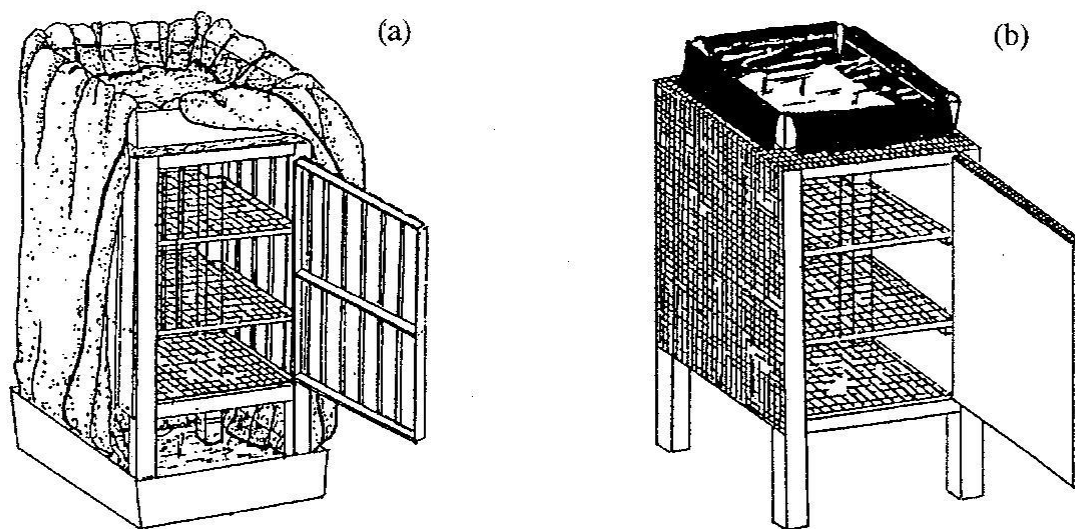

Source: Acedo, A.L. 1997. Storage life of vegetables in simple evaporative coolers. *Tropical Science* 37: 169-175.

Acedo, A.L. 1997. Ripening and disease control during evaporative cooling storage of tomatoes. *Tropical Science* 37: 209-213.

General maintenance tips and an illustration of internal design of an evaporative cooler can be found online:

<http://www.perfect-home-hvac-design.com/swamp-cooler-maintenance.html>

An evaporative cooler located in the peak of a storage structure can cool an entire room of stored produce such as sweet potatoes or other chilling-sensitive crops. The vents for outside air should be located at the base of the building so that cool air is circulated throughout the room before it can exit.

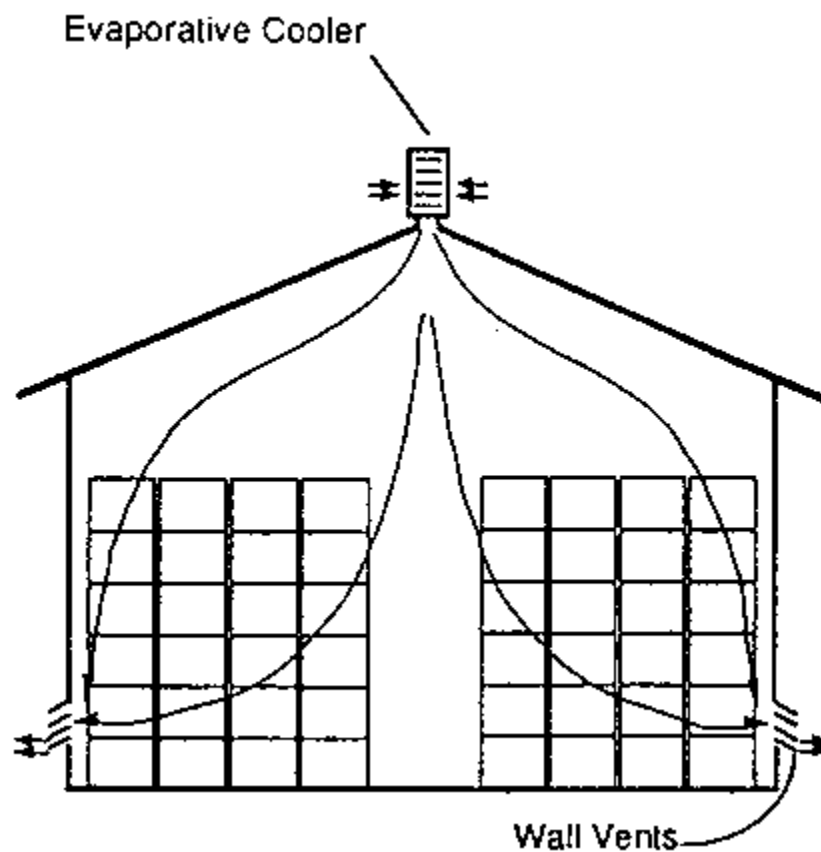

Source: Thompson, J.F. and Scheuerman, R.W. 1993. Curing and Storing California Sweet potatoes. Merced County Cooperative Extension, Merced, California 95340.

The low cost cooling chambers illustrated below are constructed from loosely stacked bricks. The cavity between the double walls is filled with sand, and the bricks and sand are kept saturated with water. Fruits and vegetables are loaded inside, and the entire chamber is covered with a rush mat that is also kept moist. The chamber can be made in any size needed. During the hot summer months in India, this chamber can maintain an inside temperature between 15 and 18 °C (59 and 65 °F) and a relative humidity of about 95%.

**Improved Zero-Energy Cool Chamber (ZECC):**

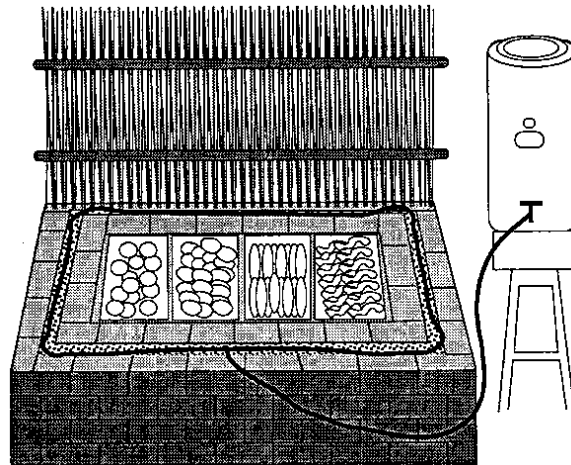

Source: Roy S.K. 1989. Postharvest technology of vegetable crops in India. Indian Horticulture. Jan-June: 76, 78.

A larger “walk-along” ZECC was designed at Amity University and constructed in 2009 in India. It is currently being used to store vegetables for use in the university cafeteria on the Amity University Manesar campus.





## Night Air Ventilation

Storage structures can be cooled using night air if the difference in day and night temperature is relatively large (Thompson in Kader, 2002). The storage facility should be well insulated and vents should be located at ground level. Vents can be opened at night, and fans can be used to pull cool air through the storeroom. The structure will best maintain cool temperatures during the heat of the day if it is well insulated and vents are closed early in the morning.

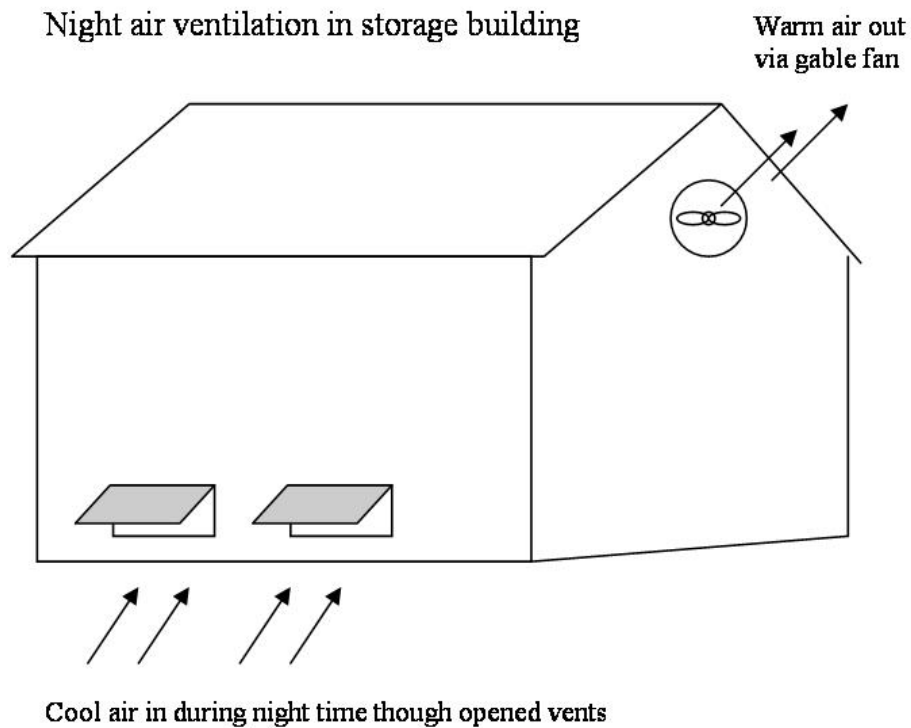

## Chilling Injury

Fruit and vegetable crops often are susceptible to chilling injury when cooled below 13 to 16 °C (55 to 60 °F). Chilling injury reduces the quality of the product and shortens shelf life. The table below provides some examples of the symptoms of chilling injury in a variety of crops. Symptoms often appear only after the commodity is returned to warmer temperatures, as when marketed.

### Fruits and vegetables susceptible to chilling injury when stored at moderately low but nonfreezing temperatures

| Commodity                                  | Approximate lowest safe temperature |       | Character of injury when stored between 0 °C and safe temperature <sup>1</sup> |
|--|-------------------------------------|-------|--|
|  | ° C / ° F                           |       |  |
| Apples (Jonathan, McIntosh, Yellow Newton) | 2-3                                 | 36-38 | Internal browning, brown core, soggy breakdown, soft scald                     |
| Asparagus                                  | 0-2                                 | 32-36 | Dull, gray-green, and limp tips  |
| Avocados                                   | 4.5-13                              | 40-55 | Grayish-brown discoloration of flesh   |
| Bananas, green or ripe                     | 11.5-13                             | 53-56 | Dull color when ripened  |
| Beans (lima)                               | 1-4.5                               | 34-40 | Rusty brown specks, spots, or areas  |
| Beans (snap)                               | 7                                   | 45    | Pitting and russetting   |
| Cranberries                                | 2                                   | 36    | Rubbery texture, red flesh   |
| Cucumbers                                  | 7                                   | 45    | Pitting, water-soaked spots, decay   |
| Eggplants                                  | 7                                   | 45    | Surface scald, <i>Alternaria</i> rot, blackening of seeds                      |
| Guavas                                     | 4.5                                 | 40    | Pulp injury, decay   |
| Grapefruit                                 | 10                                  | 50    | Scald, pitting, watery breakdown   |
| Jicama                                     | 13-18                               | 55-65 | Surface decay, discoloration   |
| Lemons                                     | 11-13                               | 52-55 | Pitting, membranous staining, red blotch                                       |
| Limes                                      | 7-9                                 | 45-48 | Pitting, turning tan with time   |
| Mangos                                     | 10-13                               | 50-55 | Grayish scald-like discoloration of skin, uneven ripening                      |
| Melons                                     |                                     |       |  |
| Cantaloupe                                 | 2-5                                 | 36-41 | Pitting, surface decay   |
| Honey Dew                                  | 7-10                                | 45-50 | Reddish-tan discoloration, pitting, surface decay, failure to ripen            |
| Casaba                                     | 7-10                                | 45-50 | Same as above but no discoloration   |
| Crenshaw and Persian                       | 7-10                                | 45-50 | Same as above but no discoloration   |
| Watermelons                                | 4.5                                 | 40    | Pitting, objectionable flavor  |
| Okra                                       | 7                                   | 45    | Discoloration, water-soaked areas, pitting, decay                              |

| Commodity                        | Approximate lowest safe temperature |       | Character of injury when stored between 0 °C and safe temperature <sup>1</sup> |
|----------------------------------|-------------------------------------|-------|--|
|                                  | ° C                                 | ° F   |  |
| Olives, fresh                    | 7                                   | 45    | Internal browning  |
| Oranges, California and Arizona  | 3                                   | 38    | Pitting, brown stain   |
| Papayas                          | 7                                   | 45    | Pitting, failure to ripen, off flavor, decay                                   |
| Peppers, sweet                   | 7                                   | 45    | Sheet pitting, <i>Alternaria</i> rot on pods and calyxes, darkening of seed    |
| Pineapples                       | 7-10                                | 45-50 | Dull green when ripened  |
| Pomegranates                     | 4.5                                 | 40    | Pitting, external and internal browning  |
| Potatoes                         | 3                                   | 38    | Mahogany browning (Chippewa and Sebago), sweetening <sup>2</sup>               |
| Pumpkins and hard-shell squashes | 10                                  | 50    | Decay, especially <i>Alternaria</i> rot  |
| Sweet potatoes                   | 13                                  | 55    | Decay, pitting, internal discoloration; hardcore when cooked                   |
| Tamarillos                       | 3-4                                 | 37-40 | Surface pitting, discoloration   |
| Tomatoes                         |                                     |       |  |
| Ripe                             | 7-10                                | 45-50 | Water-soaking and softening, decay   |
| Mature-green                     | 13                                  | 55    | Poor color when ripe, <i>Alternaria</i> rot                                    |

<sup>1</sup> Symptoms often apparent only after removal to warm temperatures, often during marketing.

<sup>2</sup> For potatoes that will be processed to chips, French fries, or other fried products, the proper storage temperature is 8 to 12 °C (46-54 °F).

Source: Harderburg, R.E., Watada, A. E. and C-Y. Wang. 1986. The Commercial Storage of Fruits Vegetables. and Florist and Nursery Stocks. USDA, Agricultural Handbook No. 66.

## Use of Ice

Crushed or flaked ice for package icing can be applied directly or as slurry in water (liquid ice). The ice must come into direct contact with the produce in order to cool, and cannot simply be placed on top of the produce. The water used to make ice must be potable (clean). Flaked or crushed ice can be manufactured using commercial machinery, but operation and storage of ice is expensive. If you use ice only for a short time during the harvest season, it is probably less expensive to purchase block ice and crush it on site.

The use of ice to cool produce provides a high relative humidity environment around the product. Packaged ice can be used only with water-tolerant, non-chilling, sensitive products and with water-tolerant packages (waxed fiberboard, plastic or wood).

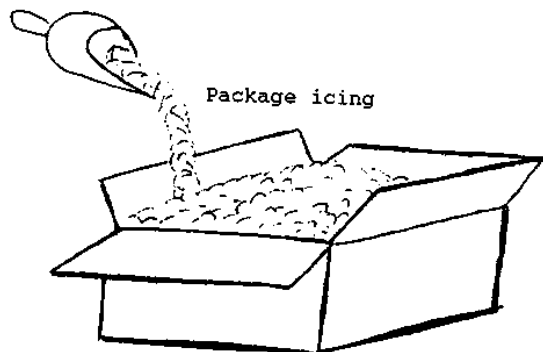

The use of ice to cool produce provides a high relative humidity environment around the product and can reduce the rate of water loss in commodities sensitive to moisture loss. Melting 1 lb. of ice made from water has the cooling effect of 144 Btu. One lb. or kg of ice will drop the temperature of produce 3 times its weight by about 28 °C (50 °F).

Using ice in plastic bags or freezable, sealed, reusable ice pouches to maintain temperature of pre-cooled produce can reduce problems with package damage from soaking, and eliminate wastewater flow from ice melt.

Top ice is used for certain products during transport to help maintain a high relative humidity. Top ice can be used only with water-tolerant, non-chilling, sensitive products (such as: carrots, sweet corn, cantaloupes, escarole, lettuce, spinach, radishes, broccoli, green onions) and with water-tolerant packages (waxed fiberboard, or wood).

Top ice on loads should be applied in rows rather than a solid mass. It is important not to block air circulation inside the transport vehicle.

| <b>Should be Top-iced:</b> | <b>Can be Top-iced:</b> |
|----------------------------|-------------------------|
| beets with tops            | artichokes, globe       |
| broccoli                   | beet greens             |
| carrots with tops          | beets topped            |
| corn sweet                 | brussels sprouts        |
| endive                     | cantaloupes             |
| escarole                   | carrots, topped         |
| green onions               | celeriac                |
| parsley                    | chard                   |
| radishes with tops         | kohlrabi                |
| radish greens              | leeks                   |
| spinach                    | mustard greens          |
| turnip                     | parsnips                |
| turnips with tops          | radishes                |
| turnip greens              | rutabagas               |
| watercress                 |                         |

Sources: Thompson, J.F. 2002. Cooling horticultural commodities. p.97-112. In: Kader, A.A. (ed.). Postharvest Technology of Horticultural Crops. Univ. of California, Div. of Agriculture and Natural Resources, Publication 3311.

McGregor, B.M. 1989. Tropical Products Transport Handbook. USDA, Office of Transportation, Agricultural Handbook Number 668.

## Alternative Methods of Cooling

### Radiant Cooling

Radiant cooling can be used to lower the air temperature in a storage structure if a solar collector is connected to the ventilation system of the building. By using the solar collector at night, heat will be lost to the environment. Temperatures inside the structure of 4 °C (about 8 °F) less than night temperature can be achieved.

### Use of Well Water

Well water is often much cooler than air temperature in most regions of the world. The water temperature of a deep well tends to be in the same range as the average air temperature of the same locality. Well water can be used for hydro-cooling and as a spray or mist to maintain high relative humidity in the storage environment.

### High Altitude Storage

Typically air temperatures decrease by 10 °C (18 °F) for every 1000 meters increase in altitude. If handlers have an option to pack and/or store commodities at higher altitude, costs could be reduced. Cooling and storage facilities operated at high altitude would require less energy than those at sea level for the same results.

As a rule, night ventilation effectively maintains product temperature when the outside air temperature is below the desired product temperature for 5 to 7 hours per night.

Sources: Thompson, J.F. 2002. Cooling horticultural commodities. p. 97-112. In: Kader, A.A. (ed.). Postharvest Technology of Horticultural Crops. Univ. of California, Div. of Agriculture and Natural Resources, Publication 3311.

## Increasing Relative Humidity

Refrigerated air tends to be lower in relative humidity than is beneficial for storage of most horticultural crops. The simplest method of increasing relative humidity of the storage air is to wet the floor of the room or mist the storage containers with cold water and allow the water to evaporate.

For a more permanent system of high relative humidity in the storage environment, moisture can be added to the refrigerated air. A fan draws air past the refrigerator's evaporator coils (R) then past wet moss or straw (M). The moist air is then pulled into the store-room through a perforated wall (P).

**Wet moss as a moisture source inside a refrigerated storeroom:**

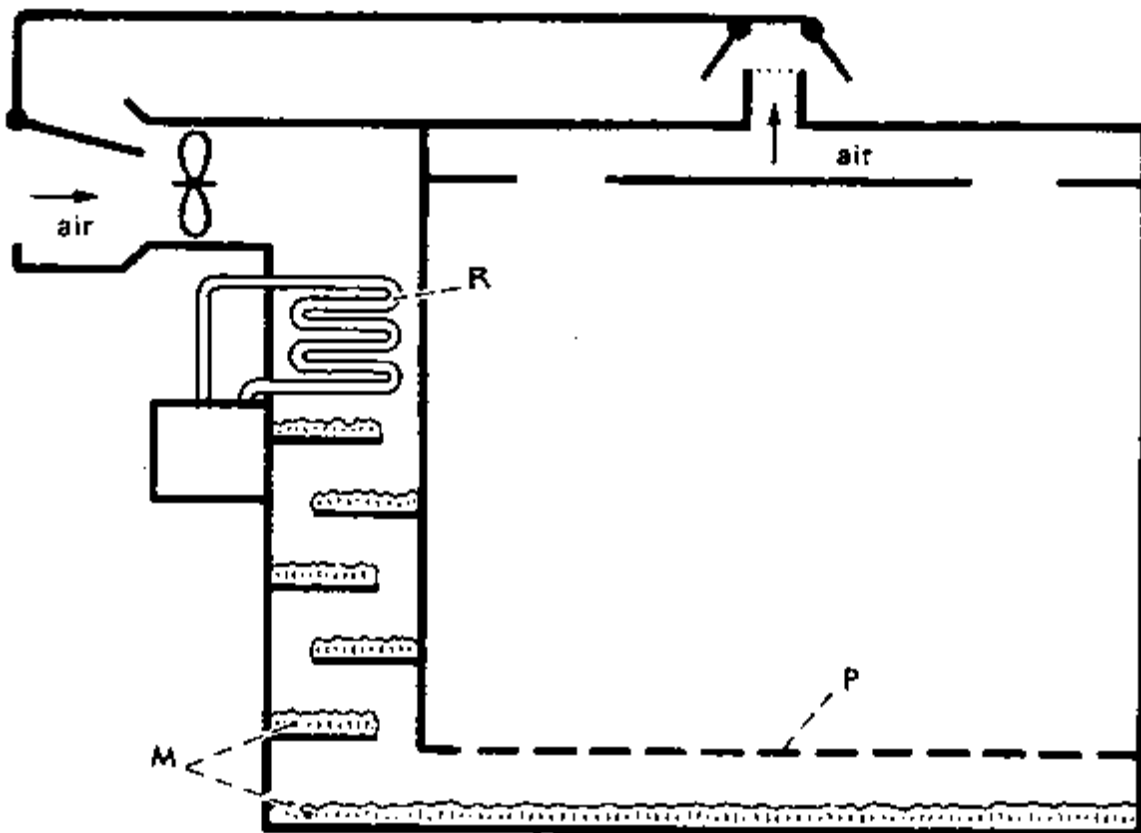

Source: Lopez, E.G. 1983. *Conservación de la Producción Agrícola*, Barcelona Editorial Aedos. p. 188.

## Maintaining the Cold Chain for Perishables

- |   |   |
|---|---|
| <b>Harvest</b>                                | <ul style="list-style-type: none"><li>• Protect the product from the sun</li><li>• Transport quickly to the packinghouse</li></ul>  |
| <b>Cooling</b>                                | <ul style="list-style-type: none"><li>• Minimize delays before cooling</li><li>• Cool the product thoroughly as soon as possible</li></ul>  |
| <b>Temporary Storage</b>                      | <ul style="list-style-type: none"><li>• Store the product at optimum temperature</li><li>• Practice first in, first out rotation</li><li>• Ship to market as soon as possible</li></ul>   |
| <b>Transport to Market</b>                    | <ul style="list-style-type: none"><li>• Use refrigerated loading area</li><li>• Cool truck before loading</li><li>• Load pallets towards the center of the truck</li><li>• Put insulating plastic strips inside door of reefer if truck makes multiple stops</li><li>• Avoid delays during transport</li><li>• Monitor product temperature during transport</li></ul> |
| <b>Handling at Destination</b>                | <ul style="list-style-type: none"><li>• Use a refrigerated unloading area</li><li>• Measure product temperature</li><li>• Move product quickly to the proper storage area</li><li>• Transport to retail markets or foodservice operations in refrigerated trucks</li><li>• Display at proper temperature range</li></ul>  |
| <b>Handling at Home or Foodservice Outlet</b> | <ul style="list-style-type: none"><li>• Store product at proper temperature</li><li>• Use the product as soon as possible</li></ul>   |



## **Chapter 7: Storage of Horticultural Crops**

If produce is to be stored, it is important to begin with a high-quality product. The lot of produce must not contain damaged or diseased units, and containers must be well-ventilated and strong enough to withstand stacking. In general, proper storage practices include temperature control, relative humidity control, air circulation and maintenance of space between containers for adequate ventilation, and avoiding incompatible product mixes.

Commodities stored together should be capable of tolerating the same temperature, relative humidity and level of ethylene in the storage environment. High ethylene producers (such as ripe bananas, apples, cantaloupes) can stimulate physiological changes in ethylene-sensitive commodities (such as lettuce, cucumbers, carrots, potatoes, sweet potatoes), which often leads to undesirable changes in color, flavor and texture.

Temperature management during storage can be aided by constructing square rather than rectangular buildings. Rectangular buildings have more wall area per square foot of storage space, so more heat is conducted across the walls, making them more expensive to cool. Temperature management can also be aided by shading buildings, painting storehouses white to help reflect the sun's rays, and using sprinkler systems on the roofs of buildings for evaporative cooling. The United Nations' Food and Agriculture Organization (FAO) recommends the use of ferrocement for the construction of storage structures in tropical regions, since thick walls provide better insulation.

Low-cost cold rooms can be constructed using concrete for floors and polyurethane foam as insulation materials. Building the storeroom in the shape of a cube will reduce the surface area per unit volume of storage space, also reducing construction and refrigeration costs. All joints should be carefully caulked and the door should have a rubber seal around the edges. While cooling produce, the ventilation system should be set to create an air flow rate of 100 cfm/ton (5 L/sec/ton). Once cooling is completed, air flow rates should be decreased to the lowest speed that will keep produce cool (20 to 40 cfm/ton is usually sufficient, according to Thompson et al., 1998). The greater the refrigerator's evaporator coil area, the less of a temperature difference between the coils and the target room temperature, and less moisture will be lost from the product as it cools. (as cited in Kader, 2002; Winrock, 2010).

Facilities located at higher altitudes can be effective, since air temperature decreases as altitude increases. Increased altitude, therefore, can make evaporative cooling, night cooling and radiant cooling more feasible. Underground storage for citrus crops is common in Southern China, while in Northwest China, apples are stored in caves (Liu, 1988). This system was widely used in the U.S. during the early 1900s.

Certain commodities, such as onions and garlic, store better in lower relative humidity environments. Curing these crops by allowing the external layers of tissue to dry out prior to handling and storage helps to protect them from decay and further water loss (see Chapter 2 for details).

Commercially constructed cold rooms can be quite expensive, but fortunately the small-scale operator has many choices. Cold rooms can be self-constructed, purchased as prefabricated units (new or used), or made from refrigerated transportation equipment such as railway cars, highway vans or marine shipping containers. The publication “Empowering Agriculture: Energy Options for Horticulture” provides a variety of cold storage options and information on the many ways to reduce cost and improve energy use efficiency (Winrock, 2010).

<http://ucce.ucdavis.edu/files/datastore/234-1386.pdf>

[http://pdf.usaid.gov/pdf\\_docs/PNADO634.pdf](http://pdf.usaid.gov/pdf_docs/PNADO634.pdf)

For more detailed information about determining the cold room size best suited for your operation and evaluating choices when purchasing or building a cold room, refer to the source below.

Source: Thompson, J.F. and Spinoglio, M. (1994). Small-scale cold rooms for perishable commodities. Family Farm Series, Small Farm Center, University of California, Davis.

The air composition in the storage environment can be manipulated by increasing or decreasing the rate of ventilation (introduction of fresh air) or by using gas absorbers such as potassium permanganate (KMnO<sub>4</sub>) or activated charcoal. Large-scale controlled or modified atmosphere storage requires complex technology and management skills, however, some simple methods are available for handling small volumes of produce.

## Best practices for storage of fresh fruits and vegetables

| <b>DO</b>   | <b>DO NOT</b>  |
|---|--|
| Store only high-quality produce that is free of damage and decay.   | Handle crops intended for storage when they are wet.   |
| Store only produce that has been harvested at its proper maturity (not over-ripe or under-mature).  | Use lower than recommended temperatures -- many commodities are susceptible to damage from freezing or chilling.                     |
| Know the requirements for the commodities you want to put into storage and follow recommendations for proper temperature, relative humidity and ventilation.  | Overload storage rooms or stack containers too close together.   |
| Cure root, tuber and bulb crops before storage.   | Store onions or garlic in high humidity environments.  |
| Provide adequate ventilation in the storage room.   | Store ethylene-sensitive commodities with those that produce ethylene.   |
| Provide shade for storage structures or paint buildings white or silver to reflect heat.  |  |
| Consider sprinkling the roof of the building with water if the heat load is very high.  |  |
| Overhanging roof extensions on storage structures are very helpful in shading the walls and ventilation openings from the sun's rays, and in providing protection from rain. An overhang of at least 1 meter (3 feet) is recommended. |  |
| Keep storage rooms clean.   |  |
| Protect storage facilities from rodents by keeping the immediate outdoor area clean, and free from trash and weeds.   |  |
| Containers must be well-ventilated and strong enough to withstand stacking.   | Stack containers beyond their stacking strength.   |
| Monitor temperature in the storage room by placing thermometers at a variety of locations.  |  |
| Store crops in a darkened room. This is especially important for potatoes, since light will stimulate solanine production (a toxic compound that cannot be destroyed by cooking).   | Store produce known for emitting strong odors (apples, garlic, onions, turnips, cabbages, potatoes) with odor-absorbing commodities. |
| Inspect stored produce regularly for signs of injury, water loss, damage and disease.   | Leave damaged or diseased produce in storage   |

## Recommended storage temperatures

Recommended Temperature and Relative Humidity, and Approximate Transit and Storage Life for Fruits and Vegetable Crops (see USDA Handbook 66 for more complete information on individual crops).

| Product                  | Temperature |       | Relative Humidity<br>(percent) | Approximate storage<br>life |
|--------------------------|-------------|-------|--------------------------------|-----------------------------|
|                          | °C          | °F    |                                |                             |
| Amaranth                 | 0-2         | 32-36 | 95-100                         | 10-14 days                  |
| Anise                    | 0-2         | 32-36 | 90-95                          | 2-3 weeks                   |
| Apples                   | -1-4        | 30-40 | 90-95                          | 1-12 months                 |
| Apricots                 | -0.5-0      | 31-32 | 90-95                          | 1-3 weeks                   |
| Artichokes, globe        | 0           | 32    | 95-100                         | 2-3 weeks                   |
| Asian pear               | 1           | 34    | 90-95                          | 5-6 months                  |
| Asparagus                | 0-2         | 32-35 | 95-100                         | 2-3 weeks                   |
| Atemoya                  | 13          | 55    | 85-90                          | 4-6 weeks                   |
| Avocados, Fuerte, Hass   | 7           | 45    | 85-90                          | 2 weeks                     |
| Avocados, Lula, Booth-1  | 4           | 40    | 90-95                          | 4-8 weeks                   |
| Avocados, Fuchs, Pollock | 13          | 55    | 85-90                          | 2 weeks                     |
| Babaco                   | 7           | 45    | 85-90                          | 1-3 weeks                   |
| Bananas, green           | 13-14       | 56-58 | 90-95                          | 14 weeks                    |
| Barbados cherry          | 0           | 32    | 85-90                          | 7-8 weeks                   |
| Bean sprouts             | 0           | 32    | 95-100                         | 7-9 days                    |
| Beans, dry               | 4-10        | 40-50 | 40-50                          | 6-10 months                 |
| Beans, green or snap     | 4-7         | 40-45 | 95                             | 7-10 days                   |
| Beans, lima, in pods     | 5-6         | 41-43 | 95                             | 5 days                      |
| Beets, bunched           | 0           | 32    | 98-100                         | 10-14 days                  |
| Beets, topped            | 0           | 32    | 98-100                         | 4-6 months                  |
| Belgian endive           | 2-3         | 36-38 | 95-98                          | 24 weeks                    |
| Bitter melon             | 12-13       | 53-55 | 85-90                          | 2-3 weeks                   |
| Black sapote             | 13-15       | 55-60 | 85-90                          | 2-3 weeks                   |
| Blackberries             | -0.5-0      | 31-32 | 90-95                          | 2-3 days                    |
| Blood orange             | 4-7         | 40-44 | 90-95                          | 3-8 weeks                   |
| Blueberries              | -0.5-0      | 31-32 | 90-95                          | 2 weeks                     |
| Bok choy                 | 0           | 32    | 95-100                         | 3 weeks                     |
| Boniato                  | 13-15       | 55-60 | 85-90                          | 4-5 months                  |
| Breadfruit               | 13-15       | 55-60 | 85-90                          | 2-6 weeks                   |
| Broccoli                 | 0           | 32    | 95-100                         | 10-14 days                  |

| Product                 | Temperature    |       | Relative Humidity<br>(percent) | Approximate storage<br>life |
|-------------------------|----------------|-------|--------------------------------|-----------------------------|
|                         | °C             | °F    |                                |                             |
| Brussels sprouts        | 0              | 32    | 95-100                         | 3-5 weeks                   |
| Cabbage, early          | 0              | 32    | 98-100                         | 3-6 weeks                   |
| Cabbage, late           | 0              | 32    | 98-100                         | 5-6 months                  |
| Cactus Leaves           | 2-4            | 36-40 | 90-95                          | 3 weeks                     |
| Cactus Pear             | 2-4            | 36-40 | 90-95                          | 3 weeks                     |
| Caimito                 | 3              | 38    | 90                             | 3 weeks                     |
| Calabaza                | 10-13          | 50-55 | 50-70                          | 2-3 months                  |
| Calamondin              | 9-10           | 48-50 | 90                             | 2 weeks                     |
| Canistel                | 13-15          | 55-60 | 85-90                          | 3 weeks                     |
| Cantaloupes (3/4-slip)  | 2-5            | 36-41 | 95                             | 15 days                     |
| Cantaloupes (full-slip) | 0-2            | 32-36 | 95                             | 5-14 days                   |
| Carambola               | 9-10           | 48-50 | 85-90                          | 3-4 weeks                   |
| Carrots, bunched        | 0              | 32    | 95-100                         | 2 weeks                     |
| Carrots, mature         | 0              | 32    | 98-100                         | 7-9 months                  |
| Carrots, immature       | 0              | 32    | 98-100                         | 4-6 weeks                   |
| Cashew apple            | 0-2            | 32-36 | 85-90                          | 5 weeks                     |
| Cauliflower             | 0              | 32    | 95-98                          | 34 weeks                    |
| Celeriac                | 0              | 32    | 97-99                          | 6-8 months                  |
| Celery                  | 0              | 32    | 98-100                         | 2-3 months                  |
| Chard                   | 0              | 32    | 95-100                         | 10-14 days                  |
| Chayote squash          | 7              | 45    | 85-90                          | 4-6 weeks                   |
| Cherimoya               | 13             | 55    | 90-95                          | 2-4 weeks                   |
| Cherries, sour          | 0              | 32    | 90-95                          | 3-7 days                    |
| Cherries, sweet         | -1 to -<br>0.5 | 30-31 | 90-95                          | 2-3 weeks                   |
| Chinese broccoli        | 0              | 32    | 95-100                         | 10-14 days                  |
| Chinese cabbage         | 0              | 32    | 95-100                         | 2-3 months                  |
| Chinese long bean       | 4-7            | 40-45 | 90-95                          | 7-10 days                   |
| Clementine              | 4              | 40    | 90-95                          | 24 weeks                    |
| Coconuts                | 0-1.5          | 32-35 | 80-85                          | 1-2 months                  |
| Collards                | 0              | 32    | 95-100                         | 10-14 days                  |
| Corn, sweet             | 0              | 32    | 95-98                          | 5-8 days                    |
| Cranberries             | 2-4            | 36-40 | 90-95                          | 24 months                   |
| Cucumbers               | 10-13          | 50-55 | 95                             | 10-14 days                  |
| Currants                | -0.5-0         | 31-32 | 90-95                          | 1-4 weeks                   |

## Storage of Horticultural Crops

| Product                    | Temperature |         | Relative Humidity<br>(percent) | Approximate storage<br>life |
|----------------------------|-------------|---------|--------------------------------|-----------------------------|
|                            | °C          | °F      |                                |                             |
| Custard apples             | 5-7         | 41-45   | 85-90                          | 4-6 weeks                   |
| Daikon                     | 0-1         | 32-34   | 95-100                         | 4 months                    |
| Dates                      | -18 or 0    | 0 or 32 | 75                             | 6-12 months                 |
| Dewberries                 | -0.5-0      | 31-32   | 90-95                          | 2-3 days                    |
| Durian                     | 4-6         | 39-42   | 85-90                          | 6-8 weeks                   |
| Eggplants                  | 12          | 54      | 90-95                          | 1 week                      |
| Elderberries               | -0.5-0      | 31-32   | 90-95                          | 1-2 weeks                   |
| Endive and escarole        | 0           | 32      | 95-100                         | 2-3 weeks                   |
| Feijoa                     | 5-10        | 41-50   | 90                             | 2-3 weeks                   |
| Figs fresh                 | -0.5-0      | 31-32   | 85-90                          | 7-10 days                   |
| Garlic                     | 0           | 32      | 65-70                          | 6-7 months                  |
| Ginger root                | 13          | 55      | 65                             | 6 months                    |
| Gooseberries               | -0.5-0      | 31-32   | 90-95                          | 34 weeks                    |
| Granadilla                 | 10          | 50      | 85-90                          | 3-4 weeks                   |
| Grapefruit, Calif. & Ariz. | 14-15       | 58-60   | 85-90                          | 6-8 weeks                   |
| Grapefruit, Fla. & Texas   | 10-15       | 50-60   | 85-90                          | 6-8 weeks                   |
| Grapes, Vinifera           | -1 to -0.5  | 30-31   | 90-95                          | 1-6 months                  |
| Grapes, American           | -0.5-0      | 31-32   | 85                             | 2-8 weeks                   |
| Greens, leafy              | 0           | 32      | 95-100                         | 10-14 days                  |
| Guavas                     | 5-10        | 41-50   | 90                             | 2-3 weeks                   |
| Haricot vert (fine beans)  | 4-7         | 40-45   | 95                             | 7-10 days                   |
| Horseradish                | -1-0        | 30-32   | 98-100                         | 10-12 months                |
| Jaboticaba                 | 13-15       | 55-60   | 90-95                          | 2-3 days                    |
| Jackfruit                  | 13          | 55      | 85-90                          | 2-6 weeks                   |
| Jaffa orange               | 8-10        | 46-50   | 85-90                          | 8-12 weeks                  |
| Japanese eggplant          | 8-12        | 46-54   | 90-95                          | 1 week                      |
| Jerusalem Artichoke        | -0.5-0      | 31-32   | 90-95                          | +5 months                   |
| Jicama                     | 13-18       | 55-65   | 65-70                          | 1-2 months                  |
| Kale                       | 0           | 32      | 95-100                         | 2-3 weeks                   |
| Kiwano                     | 10-15       | 50-60   | 90                             | 6 months                    |
| Kiwifruit                  | 0           | 32      | 90-95                          | 3-5 months                  |
| Kohlrabi                   | 0           | 32      | 98-100                         | 2-3 months                  |
| Kumquats                   | 4           | 40      | 90-95                          | 2-4 weeks                   |
| Langsat                    | 11-14       | 52-58   | 85-90                          | 2 weeks                     |

| Product                 | Temperature  |       | Relative Humidity<br>(percent) | Approximate storage<br>life |
|-------------------------|--------------|-------|--------------------------------|-----------------------------|
|                         | °C           | °F    |                                |                             |
| Leeks                   | 0            | 32    | 95-100                         | 2-3 months                  |
| Lemons                  | 10-13        | 50-55 | 85-90                          | 1-6 months                  |
| Lettuce                 | 0            | 32    | 98-100                         | 2-3 weeks                   |
| Limes                   | 9-10         | 48-50 | 85-90                          | 6-8 weeks                   |
| Lo bok                  | 0-1.5        | 32-35 | 95-100                         | 24 months                   |
| Loganberries            | -0.5-0       | 31-32 | 90-95                          | 2-3 days                    |
| Longan                  | 1.5          | 35    | 90-95                          | 3-5 weeks                   |
| Loquats                 | 0            | 32    | 90                             | 3 weeks                     |
| Lychees                 | 1.5          | 35    | 90-95                          | 3-5 weeks                   |
| Malanga                 | 7            | 45    | 70-80                          | 3 months                    |
| Mamey                   | 13-15        | 55-60 | 90-95                          | 2-6 weeks                   |
| Mangoes                 | 13           | 55    | 85-90                          | 2-3 weeks                   |
| Mangosteen              | 13           | 55    | 85-90                          | 2-4 weeks                   |
| Melons:                 |              |       |                                |                             |
| Casaba                  | 10           | 50    | 90-95                          | 3 weeks                     |
| Crenshaw                | 7            | 45    | 90-95                          | 2 weeks                     |
| Honeydew                | 7            | 45    | 90-95                          | 3 weeks                     |
| Persian                 | 7            | 45    | 90-95                          | 2 weeks                     |
| Mushrooms               | 0            | 32    | 95                             | 34 days                     |
| Nectarines              | -0.5-0       | 31-32 | 90-95                          | 2-4 weeks                   |
| Okra                    | 7-10         | 45-50 | 90-95                          | 7-10 days                   |
| Olives, fresh           | 5-10         | 41-50 | 85-90                          | +6 weeks                    |
| Onions, green           | 0            | 32    | 95-100                         | 34 weeks                    |
| Onions, dry             | 0            | 32    | 65-70                          | 1-8 months                  |
| Onion sets              | 0            | 32    | 65-70                          | 6-8 months                  |
| Oranges, Calif. & Ariz. | 3-9          | 38-48 | 85-90                          | 3-8 weeks                   |
| Oranges, Fla. & Texas   | 0-1          | 32-34 | 85-90                          | 8-12 weeks                  |
| Papayas                 | 7-13         | 45-55 | 85-90                          | 1-3 weeks                   |
| Passionfruit            | 7-10         | 45-50 | 85-90                          | 3-5 weeks                   |
| Parsley                 | 0            | 32    | 95-100                         | 2-2.5 months                |
| Parsnips                | 0            | 32    | 95-100                         | +6 months                   |
| Peaches                 | -0.5-0       | 31-32 | 90-95                          | 2-4 weeks                   |
| Pears                   | -1.5 to -0.5 | 29-31 | 90-95                          | 2-7 months                  |
| Peas, green             | 0            | 32    | 95-98                          | 1-2 weeks                   |

| Product              | Temperature |       | Relative Humidity<br>(percent) | Approximate storage<br>life |
|----------------------|-------------|-------|--------------------------------|-----------------------------|
|                      | °C          | °F    |                                |                             |
| Peas, southern       | 4-5         | 40-41 | 95                             | 6-8 days                    |
| Pepino               | 4           | 40    | 85-90                          | 1 month                     |
| Peppers, Chili (dry) | 0-10        | 32-50 | 60-70                          | 6 months                    |
| Peppers, sweet       | 7-13        | 45-55 | 90-95                          | 2-3 weeks                   |
| Persimmons, Japanese | -1          | 30    | 90                             | 34 months                   |
| Pineapples           | 7-13        | 45-55 | 85-90                          | 24 weeks                    |
| Plantain             | 13-14       | 55-58 | 90-95                          | 1-5 weeks                   |
| Plums and prunes     | -0.5-0      | 31-32 | 90-95                          | 2-5 weeks                   |
| Pomegranates         | 5           | 41    | 90-95                          | 2-3 months                  |
| Potatoes, early crop | 10-16       | 50-60 | 90-95                          | 10-14 days                  |
| Potatoes, late crop  | 4.5-13      | 40-55 | 90-95                          | 5-10 months                 |
| Pummelo              | 7-9         | 45-48 | 85-90                          | 12 weeks                    |
| Pumpkins             | 10-13       | 50-55 | 50-70                          | 2-3 months                  |
| Quinces              | -0.5-0      | 31-32 | 90                             | 2-3 months                  |
| Raddichio            | 0-1         | 32-34 | 95-100                         | 2-3 weeks                   |
| Radishes, spring     | 0           | 32    | 95-100                         | 34 weeks                    |
| Radishes, winter     | 0           | 32    | 95-100                         | 24 months                   |
| Rambutan             | 12          | 54    | 90-95                          | 1-3 weeks                   |
| Raspberries          | -0.5-0      | 31-32 | 90-95                          | 2-3 days                    |
| Rhubarb              | 0           | 32    | 95-100                         | 24 weeks                    |
| Rutabagas            | 0           | 32    | 98-100                         | +6 months                   |
| Salsify              | 0           | 32    | 95-98                          | 2-4 months                  |
| Santol               | 7-9         | 45-48 | 85-90                          | 3 weeks                     |
| Sapodilla            | 16-20       | 60-68 | 85-90                          | 2-3 weeks                   |
| Scorzonera           | 0-1         | 32-34 | 95-98                          | 6 months                    |
| Seedless cucumbers   | 10-13       | 50-55 | 85-90                          | 10-14 days                  |
| Snow peas            | 0-1         | 32-34 | 90-95                          | 1-2 weeks                   |
| Soursop              | 13          | 55    | 85-90                          | 1-2 weeks                   |
| Spinach              | 0           | 32    | 95-100                         | 10-14 days                  |
| Squashes, summer     | 5-10        | 41-50 | 95                             | 1-2 weeks                   |
| Squashes, winter     | 10          | 50    | 50-70                          | 2-3 months                  |
| Strawberries         | 0           | 32    | 90-95                          | 5-7 days                    |
| Sugar apples         | 7           | 45    | 85-90                          | 4 weeks                     |
| Sweet potatoes       | 13-15       | 55-60 | 85-90                          | 4-7 months                  |
| Tamarillos           | 3-4         | 37-40 | 85-95                          | 10 weeks                    |



| Product  | Temperature |       | Relative Humidity<br>(percent) | Approximate storage<br>life |
|--|-------------|-------|--------------------------------|-----------------------------|
|  | °C          | °F    |                                |                             |
| Tamarinds  | 7           | 45    | 90-95                          | 3-4 weeks                   |
| Tangerines, mandarins, and related citrus fruits | 4           | 40    | 90-95                          | 24 weeks                    |
| Taro root  | 7-10        | 45-50 | 85-90                          | 4-5 months                  |
| Tomatillos                                       | 13-15       | 55-60 | 85-90                          | 3 weeks                     |
| Tomatoes, mature-green                           | 18-22       | 65-72 | 90-95                          | 1-3 weeks                   |
| Tomatoes, firm-ripe                              | 13-15       | 55-60 | 90-95                          | 4-7 days                    |
| Turnips  | 0           | 32    | 95                             | 4-5 months                  |
| Turnip greens                                    | 0           | 32    | 95-100                         | 10-14 days                  |
| Ugli fruit                                       | 4           | 40    | 90-95                          | 2-3 weeks                   |
| Waterchestnuts                                   | 0-2         | 32-36 | 98-100                         | 1-2 months                  |
| Watercress                                       | 0           | 32    | 95-100                         | 2-3 weeks                   |
| Watermelons                                      | 10-15       | 50-60 | 90                             | 2-3 weeks                   |
| White sapote                                     | 19-21       | 67-70 | 85-90                          | 2-3 weeks                   |
| White asparagus                                  | 0-2         | 32-36 | 95-100                         | 2-3 weeks                   |
| Winged bean                                      | 10          | 50    | 90                             | 4 weeks                     |
| Yams   | 16          | 61    | 70-80                          | 6-7 months                  |
| Yucca root                                       | 0-5         | 32-41 | 85-90                          | 1-2 months                  |

Source: McGregor, B.M. 1989. Tropical Products Transport Handbook. Washington, D.C.: U.S. Dept. of Agriculture, Office of Transportation.



## Compatibility groups for storage of fruits and vegetables

Group 1: Fruits and vegetables, 0 to 2 °C (32 to 36 °F), 90-95% relative humidity.  
Many products in this group produce ethylene.

|                              |                                 |              |
|------------------------------|---------------------------------|--------------|
| Apples                       | Grapes (without sulfur dioxide) | Parsnips     |
| Apricots                     | Horseradish                     | Peaches      |
| Asian pears                  | Kohlrabi                        | Pears        |
| Barbados cherry              | Leeks                           | Persimmons   |
| Beets, topped                | Longan                          | Plums        |
| Berries (except cranberries) | Loquat                          | Pomegranates |
| Cashew apple                 | Lychee                          | Prunes       |
| Cherries                     | Mushrooms                       | Quinces      |
| Coconuts                     | Nectarines                      | Radishes     |
| Figs (not with apples)       | Oranges* (Florida and Texas)    | Rutabagas    |
|                              |                                 | Turnips      |

\*Citrus treated with biphenyl may give odors to other products

Group 2: Fruits and vegetables, 0 to 2 °C (32 to 36 °F), 95-100% relative humidity.  
Many products in this group are sensitive to ethylene.

|                              |   |                |
|------------------------------|---|----------------|
| Amaranth*                    | Cherries  | Parsley*       |
| Anise                        | Daikon*   | Parsnips*      |
| Artichokes*                  | Endive*   | Peas*          |
| Asparagus                    | Escarole*   | Pomegranate    |
| Bean sprouts                 | Grapes (without sulfur dioxide)                                     | Radicchio      |
| Beets*                       | Horseradish   | Radishes*      |
| Belgian endive               | Jerusalem artichoke   | Rhubarb        |
| Berries (except cranberries) | Kiwifruit   | Rutabagas*     |
| Bok choy                     | Kohlrabi*   | Salsify        |
| Broccoli*                    | Leafy greens  | Scorzonera     |
| Brussels sprouts*            | Leeks' (not with figs or grapes)                                    | Snow peas      |
| Cabbage*                     | Lettuce   | Spinach*       |
| Carrots*                     | Lo bok  | Sweet corn*    |
| Cauliflower                  | Mushrooms   | Turnips*       |
| Celeriac*                    | Onions, green* (not with figs, grapes, mushrooms, rhubarb, or corn) | Water chestnut |
| Celery*                      |   | Watercress*    |

\*these products can be top-iced

Source: McGregor, B.M. 1989. Tropical Products Transport Handbook. Washington, D.C.: U.S. Dept. of Agriculture, Office of Transportation.

Group 3: Fruits and vegetables, 0 to 2 °C (32 to 36 °F), 65-75% relative humidity. Moisture will damage these products.

|        |             |
|--------|-------------|
| Garlic | Onions, dry |
|--------|-------------|

Group 4: Fruits and vegetables, 4.5 °C (40 °F), 90-95% relative humidity.

|               |                              |             |
|---------------|------------------------------|-------------|
| Cactus leaves | Lemons*                      | Tamarillo   |
| Cactus pears  | Lychees                      | Tangelos*   |
| Caimito       | Kumquat                      | Tangerines* |
| Cantaloupes** | Mandarin*                    | Ugli fruit* |
| Clementine    | Oranges (Calif. and Arizona) | Yucca root  |
| Cranberries   | Pepino                       |             |

\* citrus treated with biphenyl may give odors to other products.

\*\* can be top-iced.

Group 5: Fruits and vegetables, 10 °C (50 °F), 85-90% relative humidity. Many of these products are sensitive to ethylene and to chilling injury.

|                           |                   |                             |
|---------------------------|-------------------|-----------------------------|
| Beans                     | Kiwano            | Pumelo                      |
| Calamondin                | Malanga           | Squash, summer (soft shell) |
| Chayote                   | Okra              | Tamarind                    |
| Cucumber                  | Olive             | Taro root                   |
| Eggplant                  | Peppers           |                             |
| Haricot vert (fine beans) | Potatoes, storage |                             |

Source: McGregor, B.M. 1989. Tropical Products Transport Handbook. Washington, D.C.: U.S. Dept. of Agriculture, Office of Transportation.

Group 6: Fruits and vegetables, 13 to 15 °C (55 to 60 °F), 85-90% relative humidity. Many of these products produce ethylene. These products also are sensitive to chilling injury.

|              |                             |                             |
|--------------|-----------------------------|-----------------------------|
| Atemoya      | Granadilla                  | Papayas                     |
| Avocados     | Grapefruit                  | Passionfruit                |
| Babaco       | Guava                       | Pineapple                   |
| Bananas      | Jaboticaba                  | Plantain                    |
| Bitter melon | Jackfruit                   | Potatoes, new               |
| Black sapote | Langsat                     | Pumpkin                     |
| Boniato      | Lemons*                     | Rambutan                    |
| Breadfruit   | Limes*                      | Santol                      |
| Canistel     | Mamey                       | Soursop                     |
| Carambola    | Mangoes                     | Sugar apple                 |
| Cherimoya    | Mangosteen                  | Squash, winter (hard shell) |
| Coconuts     | Melons (except cantaloupes) | Tomatillos                  |
| Feijoa       |                             | Tomatoes, ripe              |
| Ginger root  |                             |                             |

\*citrus treated with biphenyl may give odors to other products

Group 7: Fruits and vegetables, 18 to 21 °C (65 to 70 °F), 85-90% relative humidity.

|                      |                        |              |       |
|----------------------|------------------------|--------------|-------|
| Jicama               | Sweet potatoes*        | Watermelon*  | Yams* |
| Pears (for ripening) | Tomatoes, mature green | White sapote |       |

\*separate from pears and tomatoes due to ethylene sensitivity.

Source: McGregor, B.M. 1989. Tropical Products Transport Handbook. Washington, D.C.: U.S. Dept. of Agriculture, Office of Transportation.

## Susceptibly to Freezing Injury

These products can be injured by one light freezing:

|                              |
|------------------------------|
| Apricot                      |
| Asparagus                    |
| Avocado                      |
| Banana                       |
| Beans (snap)                 |
| Berries (except cranberries) |
| Cucumber                     |
| Eggplant                     |
| Lemons                       |
| Lettuce                      |
| Limes                        |
| Okra                         |
| Peaches                      |
| Peppers (sweet)              |
| Plums                        |
| Potatoes                     |
| Squash (summer)              |
| Sweet potato                 |
| Tomatoes                     |

Source: McGregor, B.M. 1989. Tropical Products Transport Handbook. Washington, D.C.: U.S. Dept. of Agriculture, Office of Transportation.

## Storage Practices

Inspecting stored produce and cleaning storage structures on a regular basis will help reduce losses by minimizing the buildup of pests and discouraging the spread of diseases.

**Inspect produce and clean the storage structure:**



**Clean and maintain the storage structure:**



Source: FAO. 1985. Prevention of Post-Harvest Food Losses: A Training Manual. Rome: UNFAO. p.120.

Storage facilities should be protected from rodents by keeping the immediate area clean, free from trash and weeds. Rat guards can be made from simple materials such as old tin cans or pieces of sheet metal fashioned to fit the extended legs of storage structures. If desired, more elaborate technologies can be used. Concrete floors will help prevent rodent entry, as will screens on windows, vents and drains.

**Remove trash and weeds:**

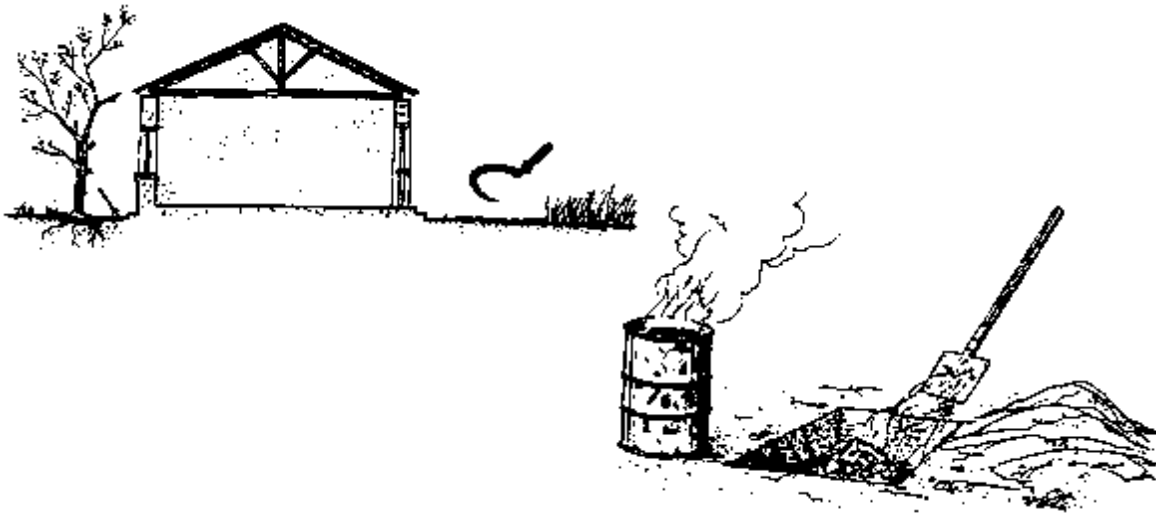

**Rat guards:**

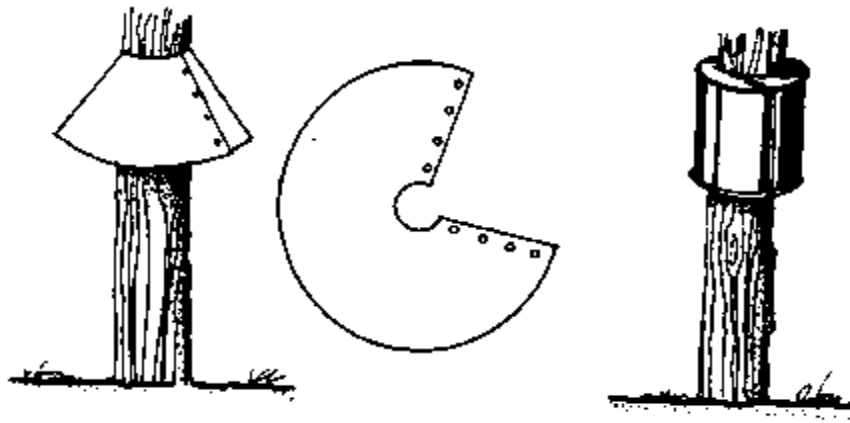

Source: FAO. 1985. Prevention of Post-Harvest Food Losses: A Training Manual. Rome: UNFAO. p.120.

**Screens:**

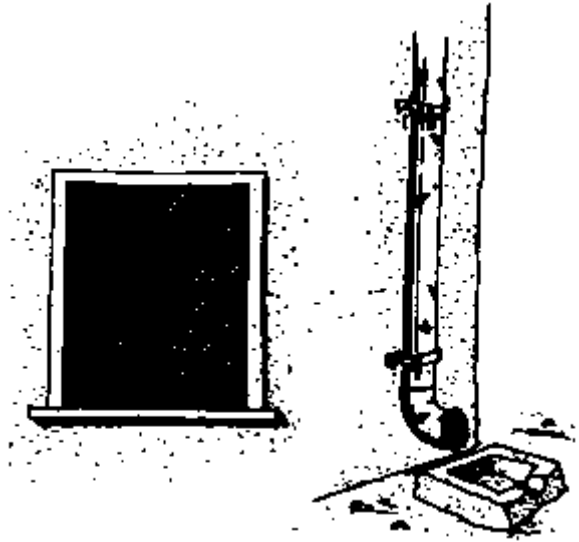

**Cement floors:**

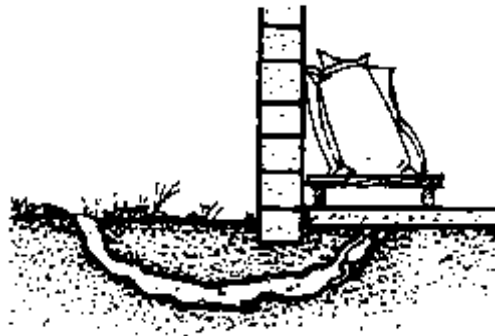

Source: FAO. 1985. Prevention of Post-Harvest Food Losses: A Training Manual. Rome: UNFAO. p. 120.



When inspecting stored produce, any spoiled or infected produce should be removed and destroyed. In some cases, produce may still be fit for consumption if used immediately, perhaps as animal feed. Reusable containers and sacks should be disinfected in chlorinated or boiling water before reuse.

**Disinfect used sacks:**

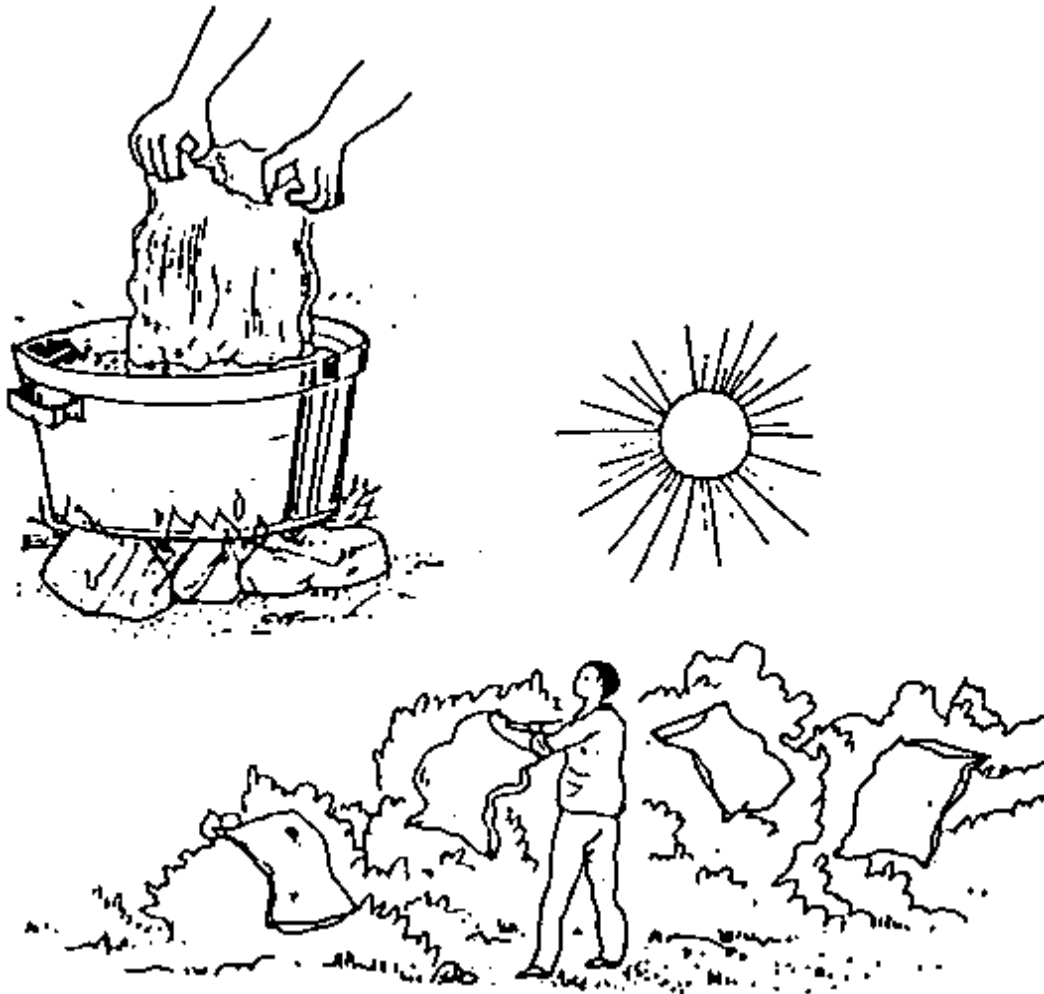

Source: FAO. 1985. Prevention of Post-Harvest Food Losses: A Training Manual. Rome: UNFAO. p. 120.

Placing materials on the floor beneath sacks or cartons of produce prevents dampness from reaching produce suited to dry conditions in storage. This helps to reduce the chance of fungal infection, while also improving ventilation and/or sanitation in the storeroom. Some examples of useful materials follow:

**Waterproof sheets:**

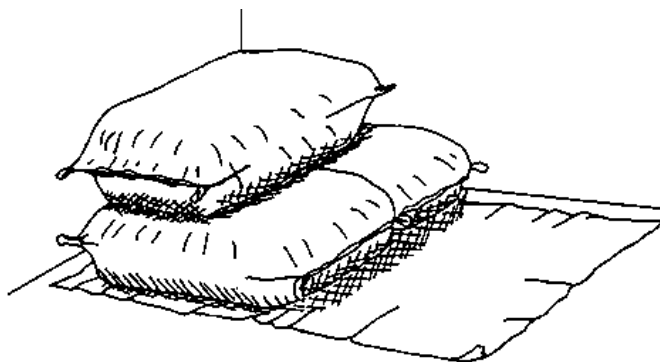

**Poles:**

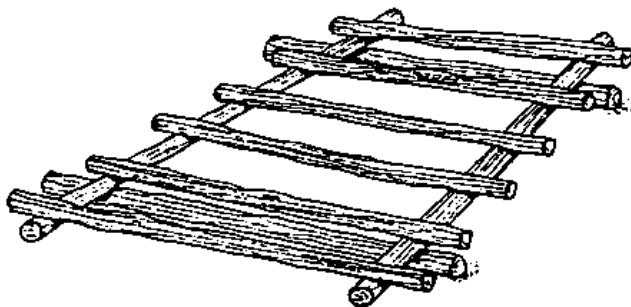

**Wooden pallets:**

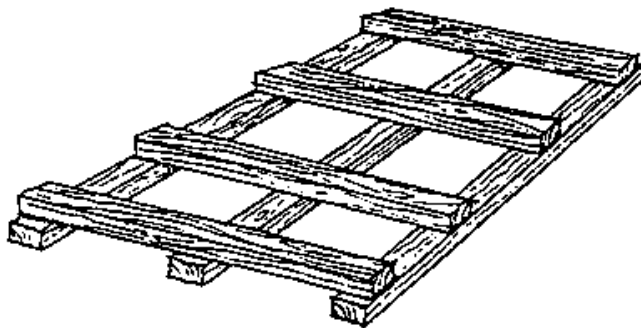

Source: FAO. 1985. Prevention of Post-Harvest Food Losses: A Training Manual. Rome: UNFAO. p. 120.

## Storage Structures

A yam barn is a traditional structure used in West Africa to store yams after curing. Fast-growing, live trees are used to create a rectangular structure, and form the framework of the barn as well as provide shade.

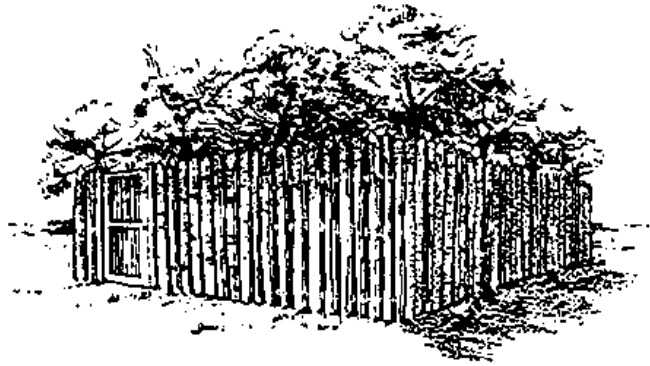

Outside view of barn with 'live' shade

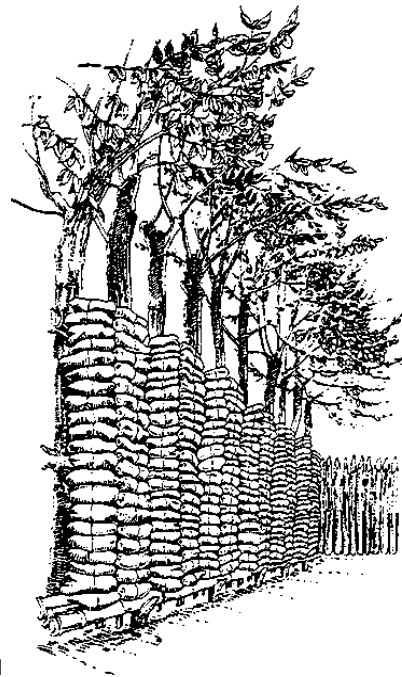

Trunks of fast growing trees planted in situ

Source: Wilson, J. (n.d.). Careful Storage of Yams: Some Basic Principles to Reduce Losses. London, England: Commonwealth Secretariat/International Institute of Tropical Agriculture.

Storage facilities require adequate ventilation in order to help extend shelf life and maintain produce quality. The following are three types of fans found in common use.

**Centrifugal:**

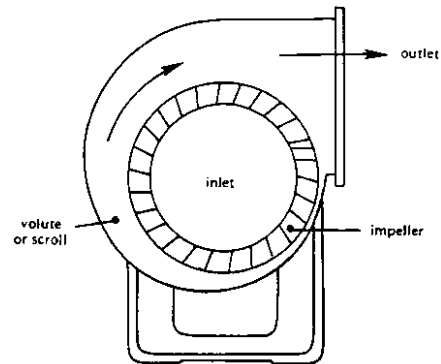

**Axial flow:**

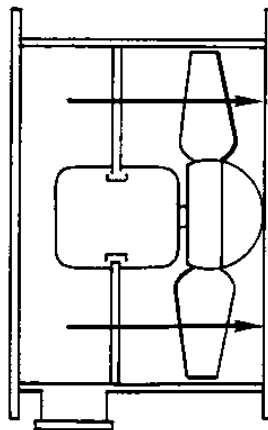

**Propeller/expeller:**

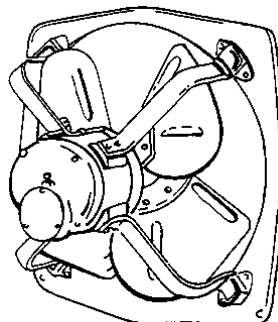

Source: Potato Marketing Board. (n.d.). Control of Environment. Part 2. London: Sutton Bridge Experiment Station, Report No. 6

Ventilation in storage structures is improved if air inlets are located at the bottom of the store, while air outlets are at the top. A simple, light-proof exhaust vent is a pressure-relief flap.

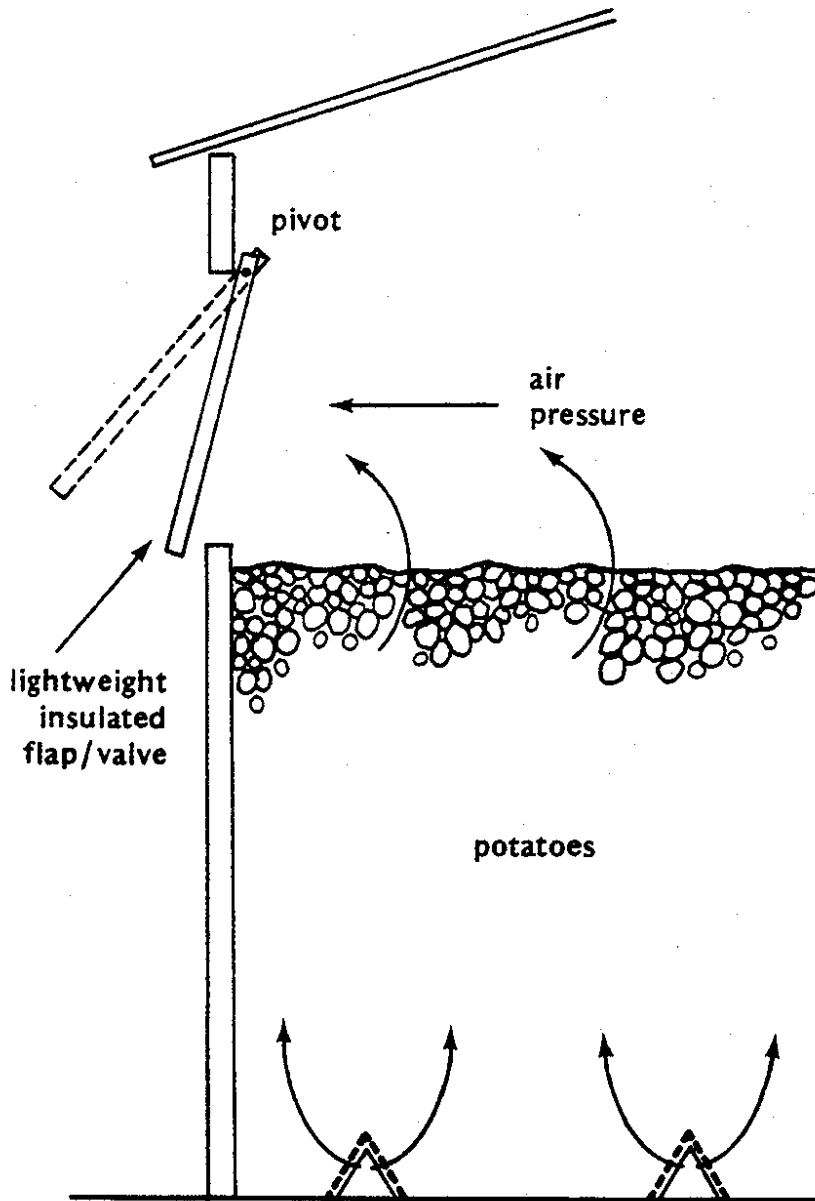

Source: Potato Marketing Board. (n.d.). Control of Environment. Part 2. London: Sutton Bridge Experiment Station, Report No. 6

Any type of building or facility used for storing horticultural crops should be insulated for maximum effectiveness. A well-insulated refrigerated building will require less electricity to keep produce cool. If the structure is to be cooled by evaporative or night air ventilation, a well-insulated building will hold the cooled air longer. Insulation R-values are listed below for some common building materials. R refers to resistance and the higher the R-value, the higher the material's resistance to heat conduction and the better the insulating property of the material.

| <b>R – Value</b>                                   |                                   |
|--|-----------------------------------|
| <b>Material</b>                                    | <b>1 inch (2.5 cm) thick</b>      |
| <b>Batt and Blanket Insulation</b>                 |                                   |
| Glass wool, mineral wool, or fiberglass            | 3.50                              |
| <b>Fill-Type Insulation</b>                        |                                   |
| Cellulose  | 3.50                              |
| Glass or mineral wool                              | 2.50-3.00                         |
| Vermiculite  | 2.20                              |
| Wood shavings or sawdust                           | 2.22                              |
| <b>Rigid Insulation</b>                            |                                   |
| Plain expanded extruded polystyrene                | 5.00                              |
| Expanded rubber                                    | 4.55                              |
| Expanded polystyrene molded beads                  | 3.57                              |
| Aged expanded polyurethane                         | 6.25                              |
| Glass fiber  | 4.00                              |
| Polyisocyanate                                     | 8.00                              |
| Wood or cane fiber board                           | 2.50                              |
| <b>Foamed-in-Place Insulation</b>                  |                                   |
| Sprayed expanded urethane                          | 6.25                              |
| <b>Building Materials</b>                          | <b>Full thickness of material</b> |
| Solid concrete                                     | 0.08                              |
| 8-inch concrete block, open core                   | 1.11                              |
| 8-inch lightweight concrete block open core        | 2.00                              |
| 8-inch concrete block with vermiculite in core     | 5.03                              |
| Lumber, fir or pine                                | 1.25                              |
| Metal siding                                       | <0.01                             |
| 3/8-inch plywood                                   | 1.25 - 0.47                       |
| 1/2-inch plywood                                   | 1.25 - 0.62                       |
| Masonite particleboard                             | 1.06                              |
| 25/32-inch insulated sheathing                     | 2.06                              |
| 1/2-inch Sheetrock                                 | 0.45                              |
| 1/2-inch wood lapsiding                            | 0.81                              |
| Reflectix (1/4 inch bubble/aluminum foil sheeting) | 6.00                              |

Source: Boyette, M.D. et al. (n.d.). Design of Room Cooling Facilities: Structural and Energy Requirements. North Carolina Agricultural Extension Service.

Low-cost cold rooms can be constructed using concrete for floors and polyurethane foam as an insulator. Building the storeroom in the shape of a cube will reduce the surface area per unit volume of storage space, thereby reducing construction and refrigeration costs. All joints should be caulked and the door should have a rubber seal.

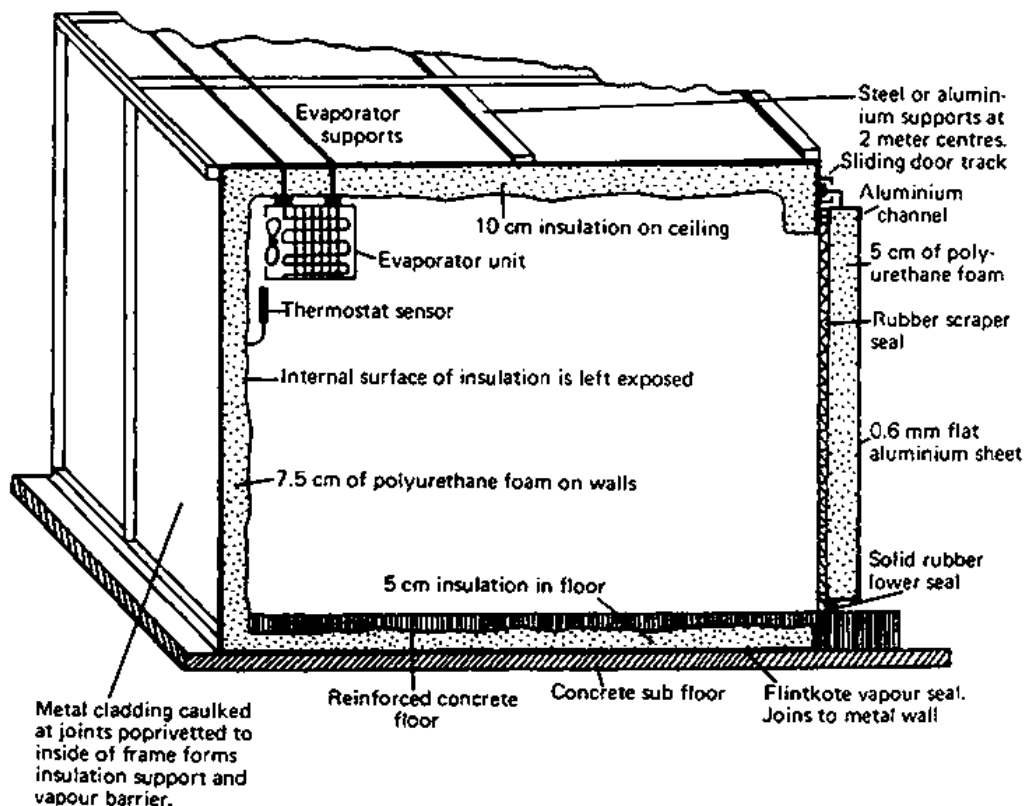

Source: Tugwell, B.L. (n.d.). Coolroom construction for the fruit and vegetable grower. Department of Agriculture and Fisheries, South Australia. Special Bulletin 11.75.

Illustrated below is a cross-sectional view of a storehouse for fruits. This system was officially approved as the standard model for farm-level storehouses by the Korean Ministry of Construction in 1983. Note that air inlets are at the base of the building, and the floor is perforated, allowing free movement of air. The entire building is set below ground level taking advantage of the cooling properties of soil.

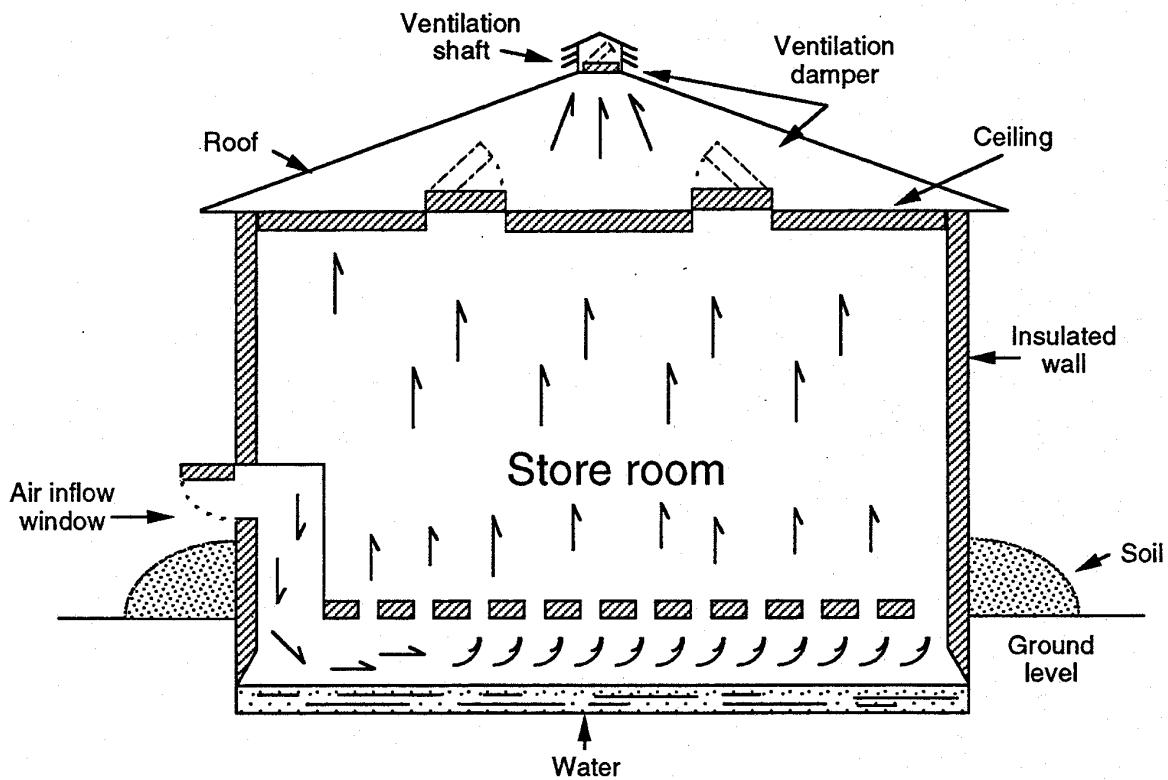

Source: Seung, K.L. 1994. Assoc. Prof., Postharvest Technology Lab., Department of Horticulture, Seoul National University, Korea. Suwon, p. 441-744.



## Charcoal Cool Rooms

Low-cost evaporative cooled storage rooms can be constructed using wire mesh walls filled with loosely packed charcoal. Typically the frame is made from wood, and the mesh is attached to the frame on both sides. The charcoal is added from the top of each wall, and a drip system is used to keep the walls wet. A sturdy roof is constructed to keep out sun, rain and dust.

Plans for construction of a charcoal cool room can be found on this website:  
<http://www.postharvest.org/images/CharcoalcoolstoragePNACQ751.pdf>

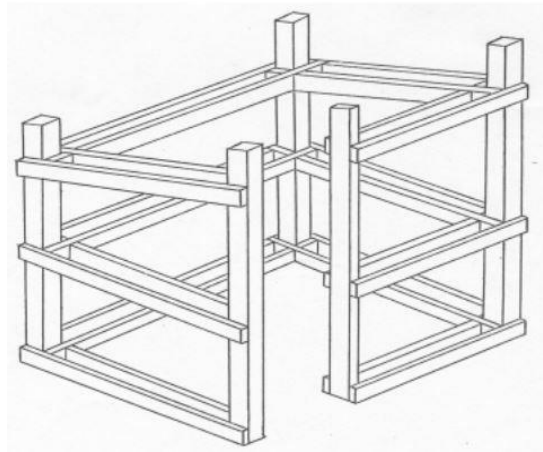

Frame for cool room.



Source: Nenguwo, N. 2000. Appropriate Technology Cold Store Construction and Review of Post-harvest Transport and Handling Practices for Export of Fresh Produce from Rwanda. Chemonics International.

This website can help you to determine whether evaporative cooling will work in your location: **Will evaporative cooling work in your climate zone?**

Using outside air for ventilation is a waste of energy for storage facilities that are already refrigerated. For these systems, a simple recirculation system can be designed by adding a fan below floor level and providing a free space at one end of the storeroom for cool air to return to the inlet vents.

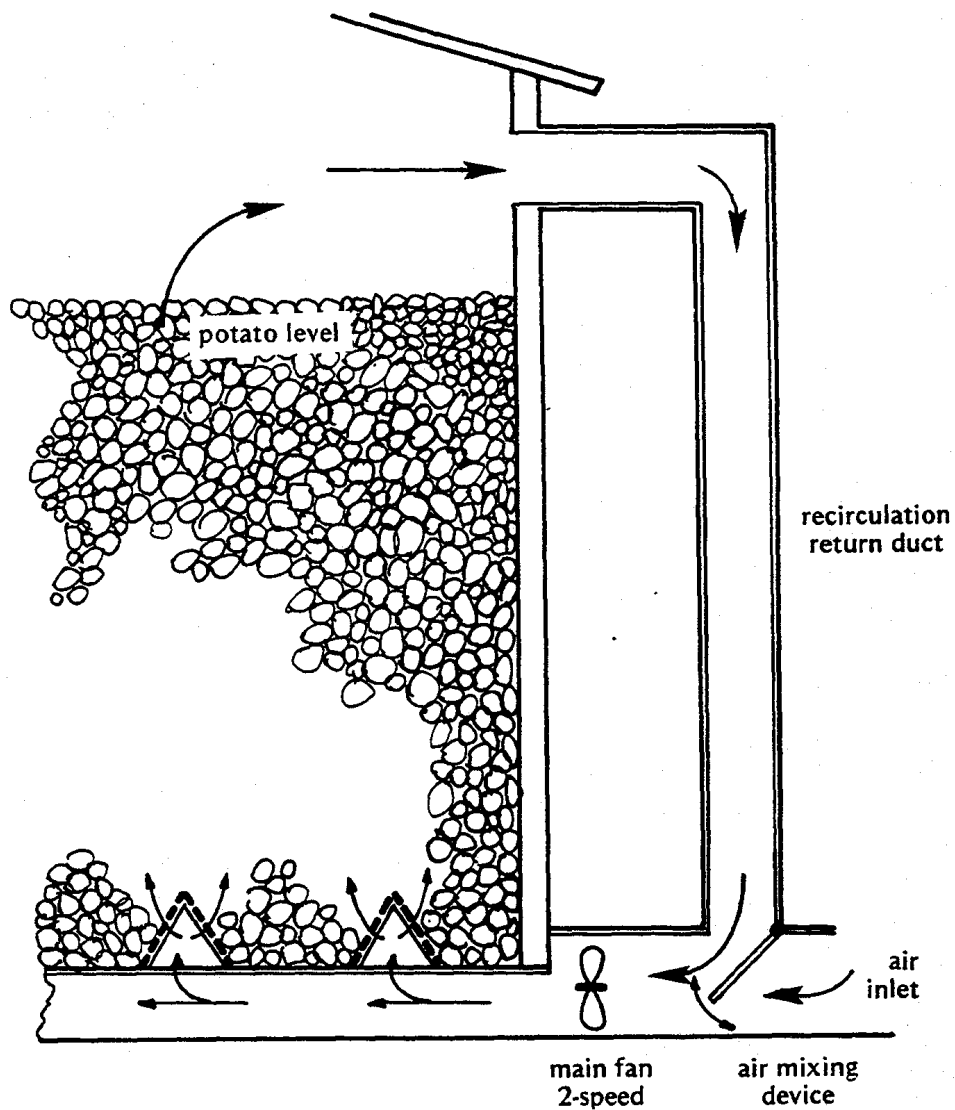

Source: Potato Marketing Board. (n.d.). Control of Environment. Part 2. London: Sutton Bridge Experiment Station, Report No. 6.

The proper arrangement of floor vents for air circulation will improve ventilation in the storage house. Lateral ducts should be meters apart when measured from center to center. Air flow velocities from the main duct should be 10 to 13 m/s.

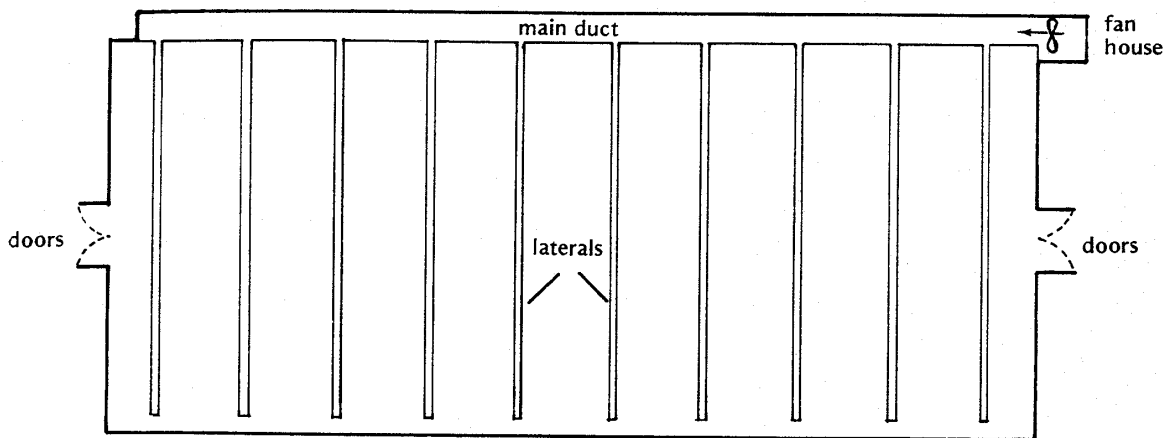

**Central main duct:**

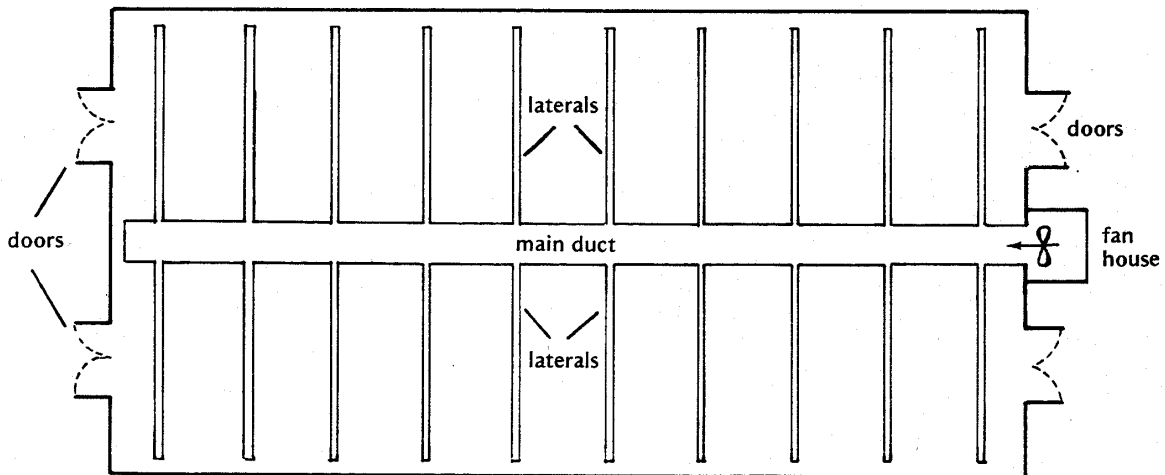

Source: Potato Marketing Board. (n.d.). Control of Environment. Part 2. London: Sutton Bridge Experiment Station, Report No. 6.

Lateral ducts can be constructed with a variety of materials. Portable vents can be made from wooden slats, in a triangular, square or rectangular design. A round tube of plastic or clay can be used if holes can be drilled without causing structural damage, or permanent ducts can be constructed below ground, using concrete blocks.

**Triangular wooden duct:**

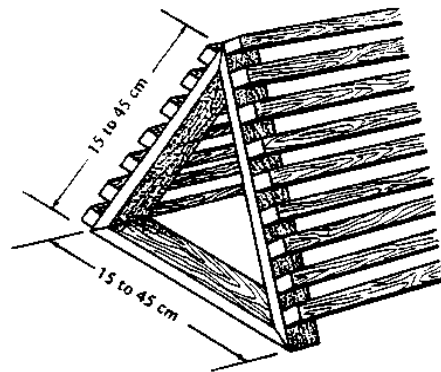

**Clay pipe duct:**

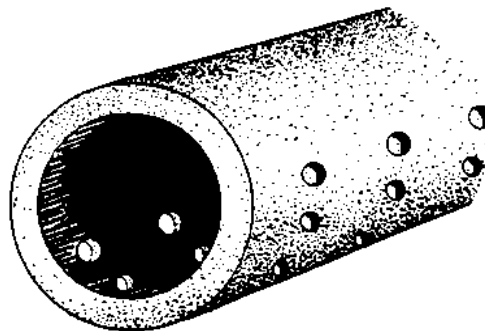

**Sunken concrete duct:**

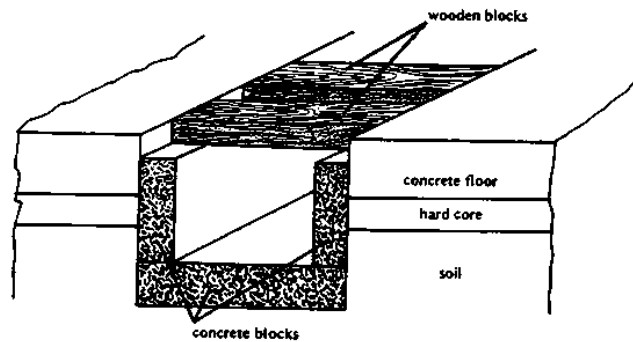

Source: Potato Marketing Board. (n.d.). Control of Environment. Part 2. London: Sutton Bridge Experiment Station, Report No. 6.

In cooler regions, suitable storage temperatures can be maintained by bringing outside air into the storage facility. Typical fan installations for a pressurized ventilation system are illustrated below. Overhead distribution of air simplifies the storehouse design. An indoor recirculation inlet can be added if refrigeration is in use. Ducts can be constructed of wood, plastic tubing or any suitable material.

#### Overhead ventilation distribution system:

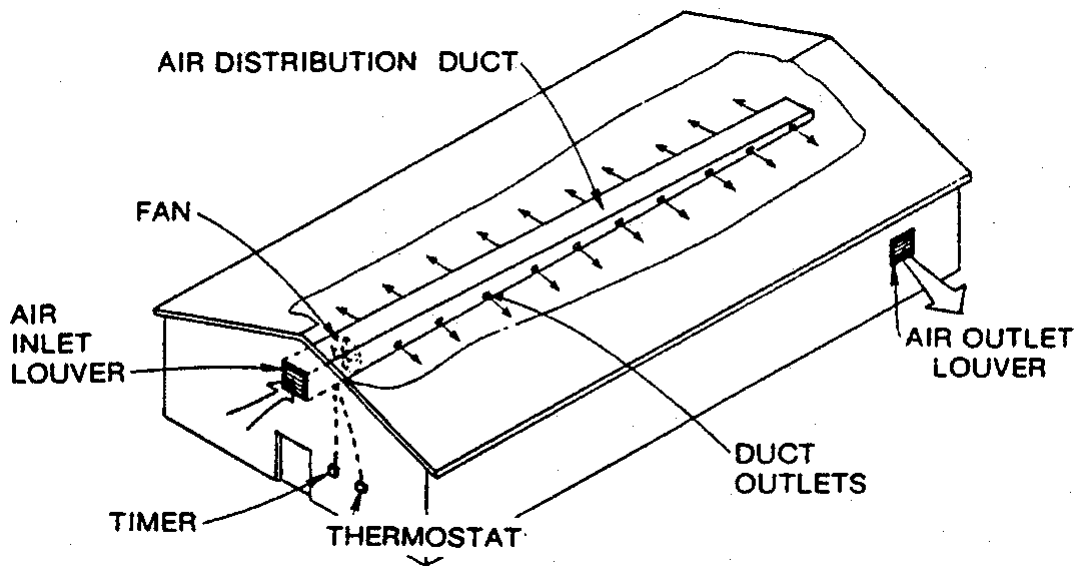

#### Types of ducts for air inlet fans:

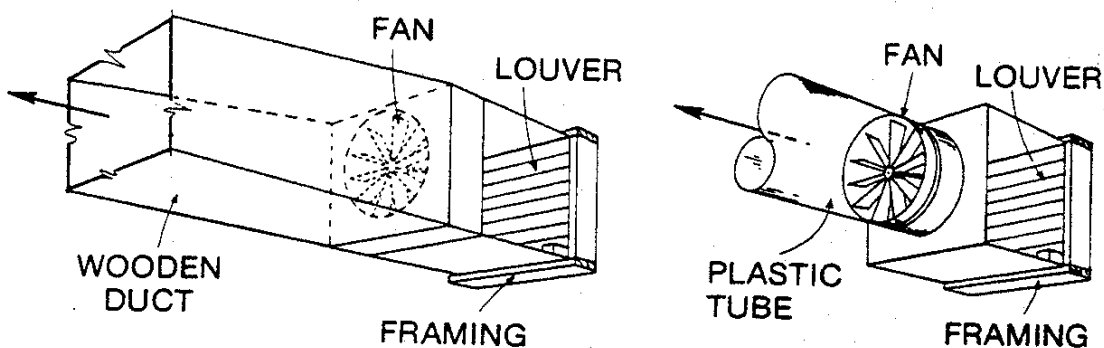

Source: Davis, R. et al. (n.d.). Storage Recommendations for Northern Onion Growers. Cornell University Extension Information Bulletin 148.

Storage structures can be cooled by ventilating at night when outside air is cool. For best results, air vents should be located at the base of the storage structure. An exhaust fan located at the top of the structure pulls the cool air through the storeroom. Vents should be closed at sunrise, and remain closed during the heat of the day.

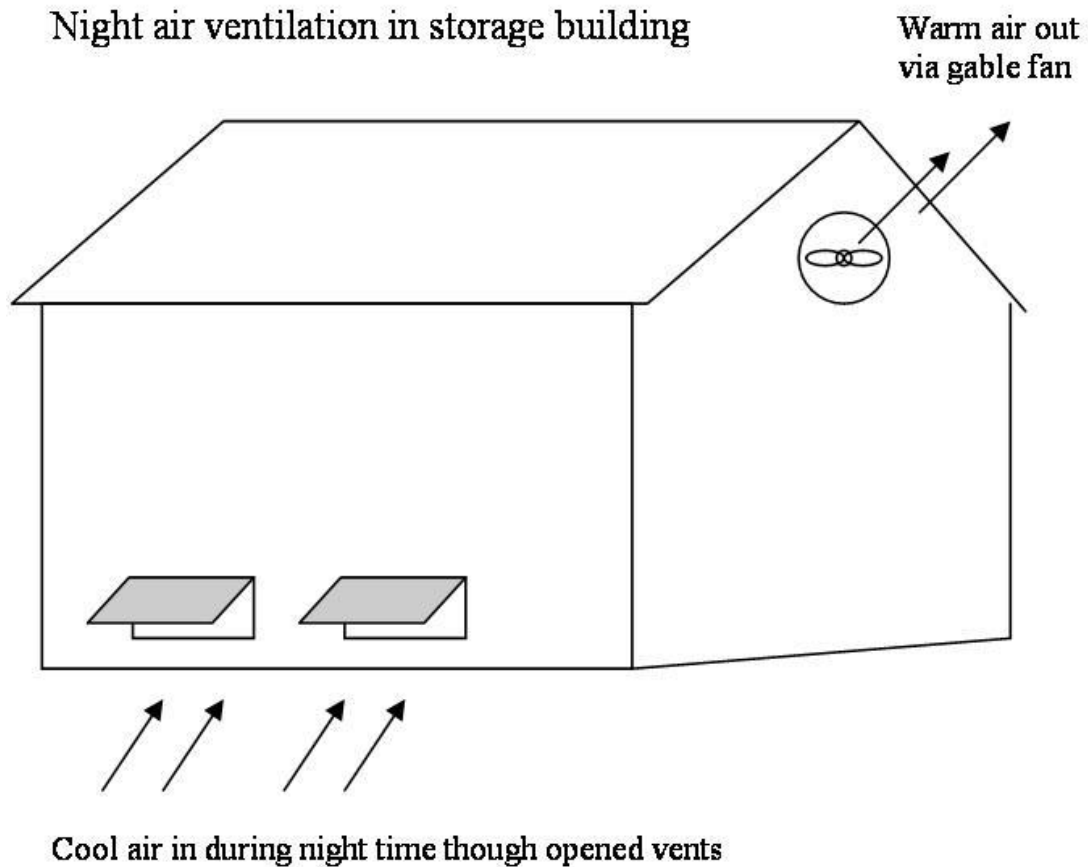

Overhanging roof extensions on storage structures are very helpful in shading the walls and ventilation openings from the sun's rays, and in providing protection from rain. An overhang of at least 1 meter (3 feet) is recommended.

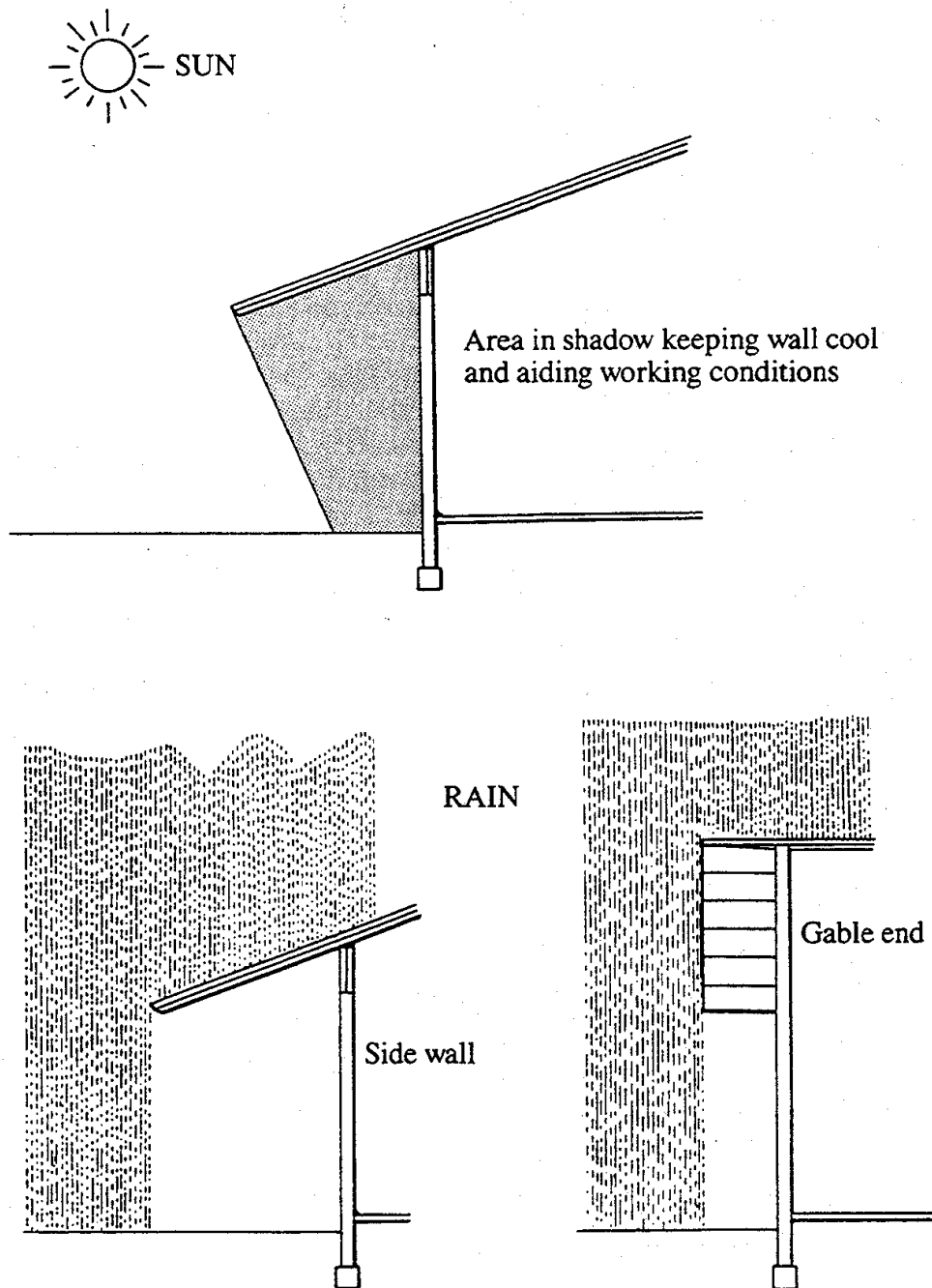

Source: Walker, D.J. 1992. World Food Programme Food Storage Manual. Chatham, UK: Natural Resources Institute.

Where electricity is not available, wind-powered turbines can help keep storerooms cool by pulling air up through the building. Vents at the floor level are especially useful for cooling via night air ventilation.

The turbine illustrated below can be constructed of sheet metal that is twisted to catch the wind, and attached to a central pole that acts as the axis of rotation. Warm air in the storage room rises, causing the turbine to rotate, expelling the air and initiating an upward flow of warm air. The turbine should be placed on the peak of the roof of a storage structure.

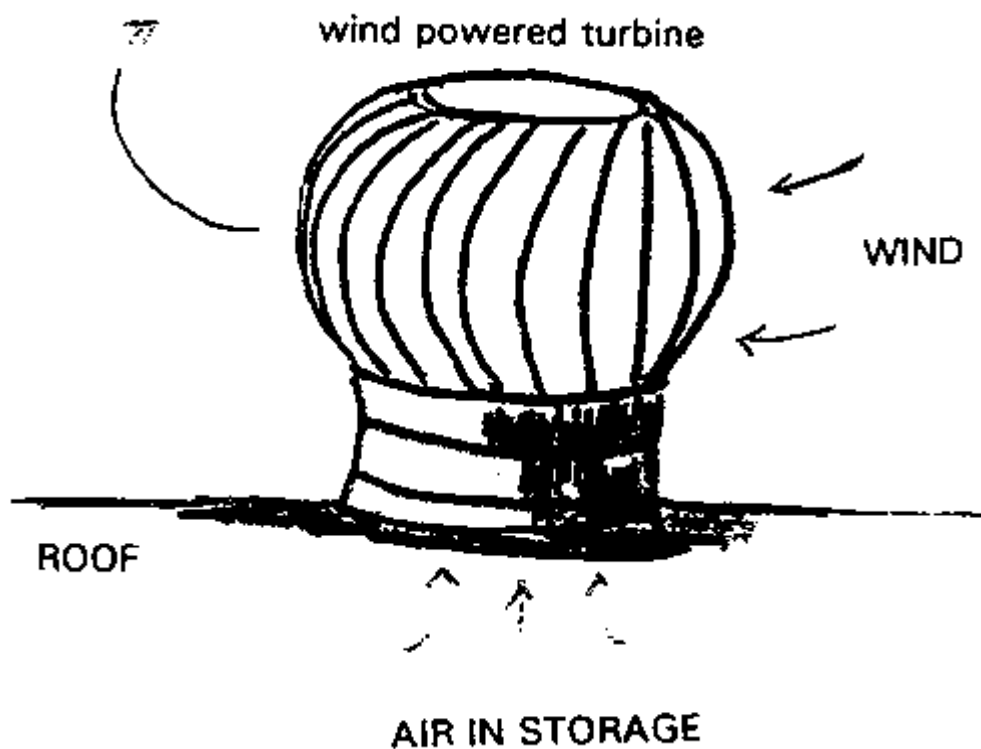



Protected surface storage is a simple method for storing small quantities of produce. The examples illustrated below are especially good for storage when night temperatures are lower than that desired for proper storage. Insulating materials such as straw can be used and protective covers can be constructed from wooden planks, plastic sheeting or layers of compacted soil.

#### Cone-shaped pit storage:

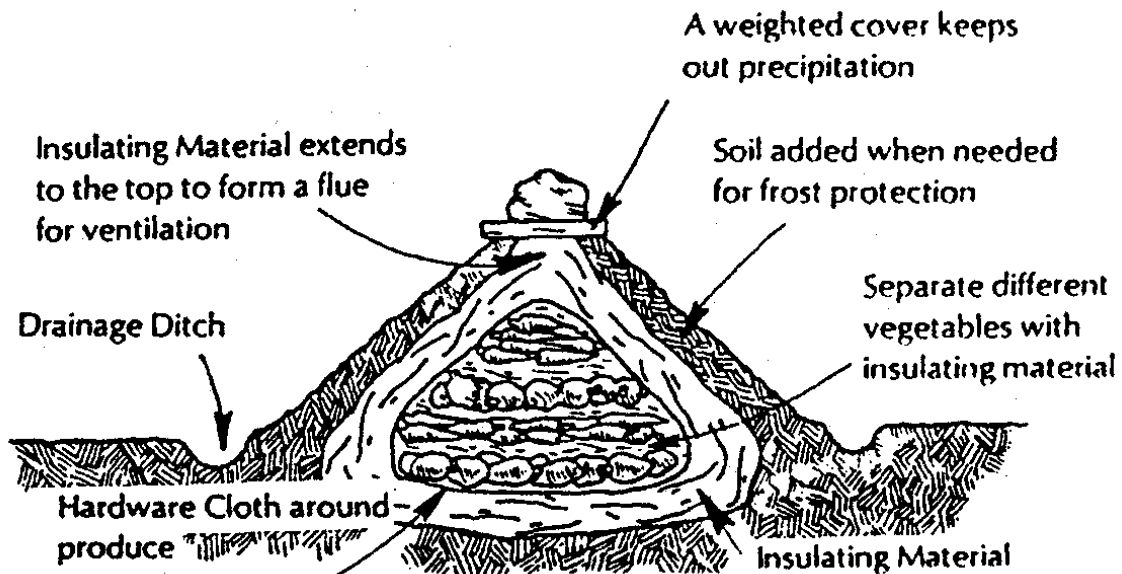

#### Mound storage:

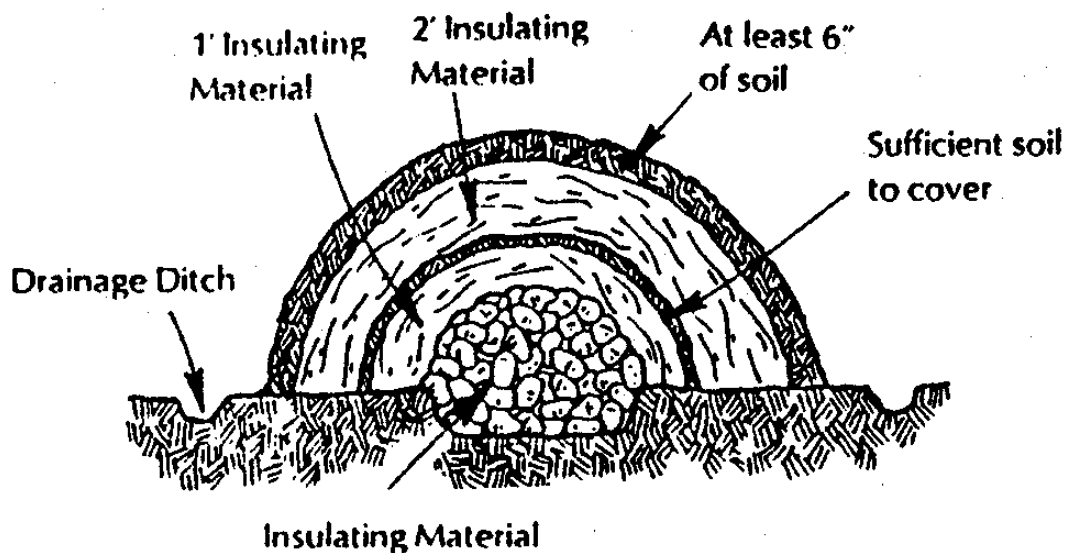

Source: McKay, S. 1992. Home Storage of Fruits and Vegetables. Northeast Regional Agricultural Engineering Service Publication No. 7.

**Trench Storage:**

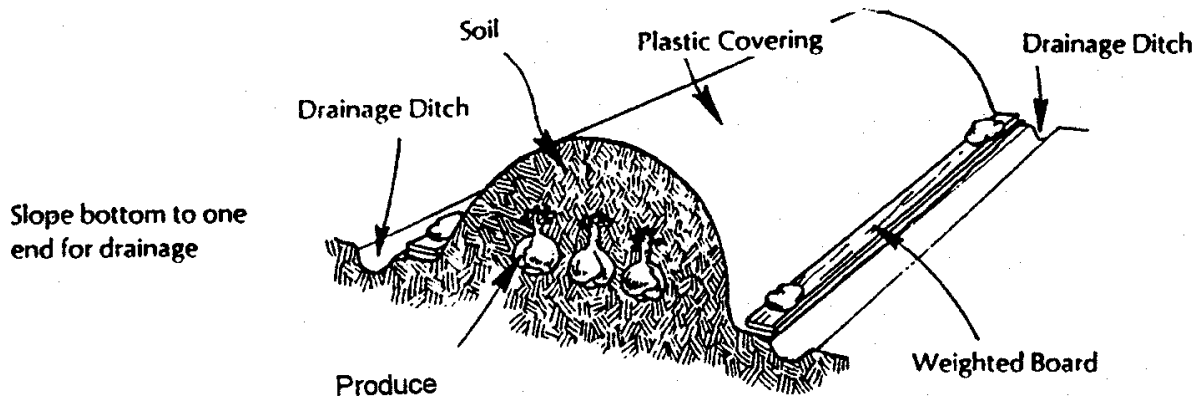

Source: McKay, S. 1992. Home Storage of Fruits and Vegetables. Northeast Regional Agricultural Engineering Service Publication No. 7.

One of the simplest methods for storing small quantities of produce is to use any available container, and create a cool environment for storage by burying the container using insulating materials and soil. The example provided here employs a wooden barrel and straw for insulation.

**Storage barrel:**

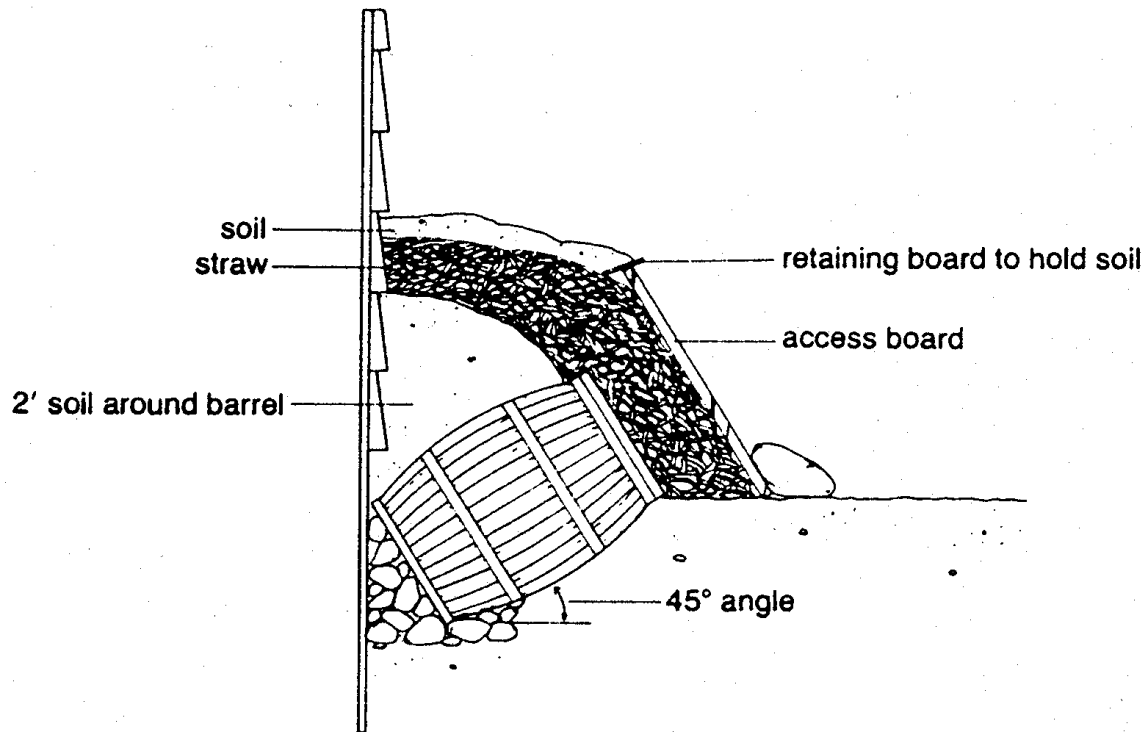

Source: Bubel, M. and Bubel, N. 1979. Root Cellaring: The Simple, No-Processing Way to Store Fruits and Vegetables. Emmaus, PA: Rodale Press. p. 297.

A root cellar can be constructed by digging out a pit to a depth of about 2 meters (7 to 8 feet) and framing the sides with wooden planks or cinder blocks. The example illustrated here is about 3 by 4 meters (12 by 15 feet) in size, with a 35 cm square (one foot square) wooden chute as a roof vent. Before covering the cellar with a thick layer (0.6 meters / 2 feet) of soil, cover the roofing materials with roofing tar and the cinderblocks with cement plaster.

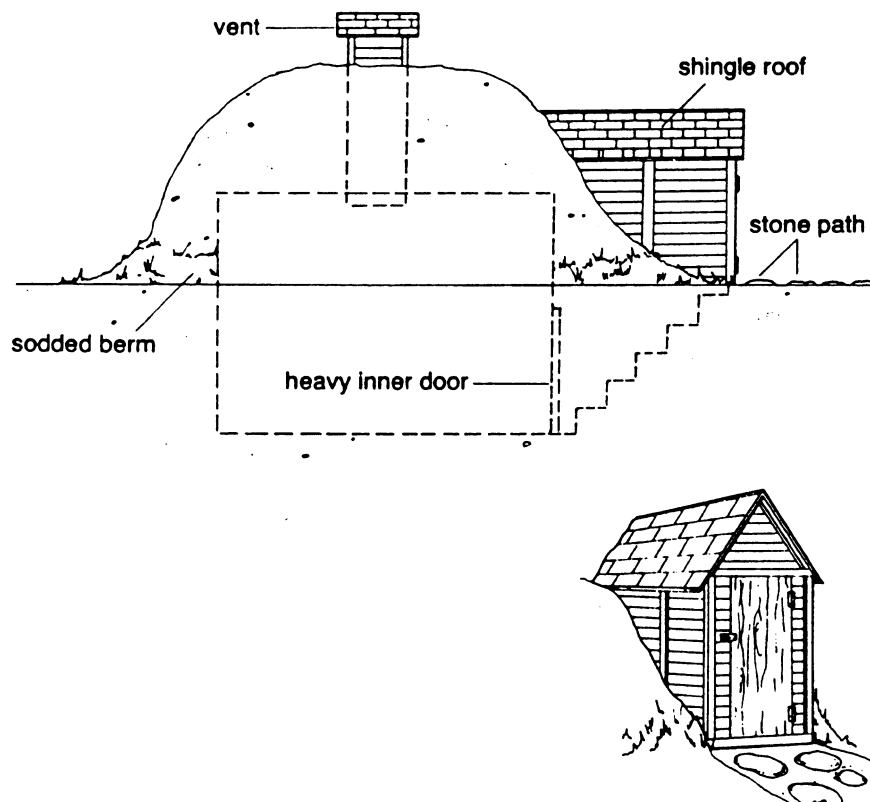

Ideally, the root cellar should be located on a sloping site. Avoid low-lying areas or the cellar may become water-logged. Stay away from trees, since the roots will eventually invade the cellar walls. Costs for a root cellar constructed using new materials may run to \$1,200 or more, and it will have a useful life of at least 20 years. To cut costs, consider building with used cinderblocks, recycled wood or using sand to fill the cavities of the blocks instead of purchasing new insulation materials.

Sources: Bubel, M. and Bubel, N. 1979. Root Cellaring: The Simple. No-Processing Way to Store Fruits and Vegetables. Emmaus, PA: Rodale Press. p. 297.

Hobson, Phyllis. 1981. Build your own underground root cellar. Storey Communications, Inc. p. 32.

An outdoor storage bin can serve as a place to keep small quantities of potatoes in a region with a cool but not freezing climate. A wooden rack provides an air space for ventilation and straw provides insulation. The best location for such a structure would be in a shady spot.

### Storage bin:

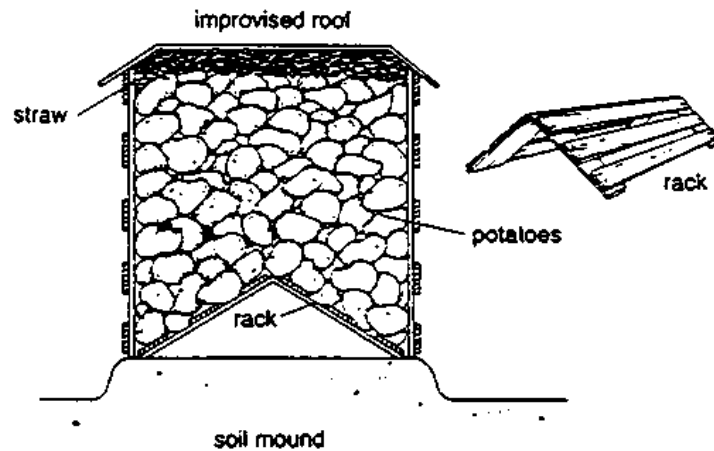

A root box, lined with hardware cloth and straw, buried to the top edge in soil will keep potatoes cool while providing protection from freezing. The wooden lid can be lifted for easy access to the produce, and straw bales on top provide more insulation.

### Root box:

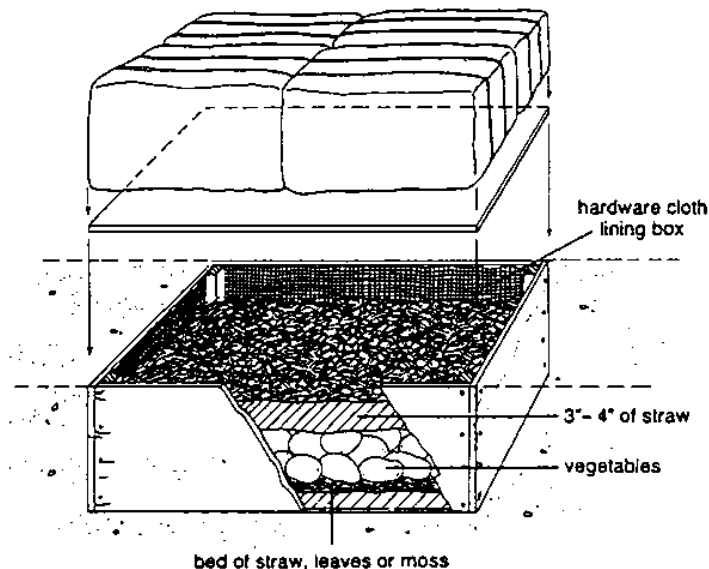

Source: Bubel, M. and Bubel, N. 1979. Root Cellaring: The Simple No-Processing Way to Store Fruits and Vegetables. Emmaus, PA: Rodale Press. p. 297.

## Storage of Dried and Bulb Crops

Onions, garlic and dried produce are best suited to low humidity in storage. Onions and garlic will sprout if stored at intermediate temperatures. Pungent types of onions have high soluble solids and will store longer than mild or “sweet” onions, which are rarely stored for more than one month.

For long term storage, onions are generally sprayed with maleic hydrazide (MH) a few weeks before harvest to inhibit sprouting during storage.

The following table lists the storage conditions recommended for these crops.

|                             | Temperature |       | RH    | Potential storage duration |
|-----------------------------|-------------|-------|-------|----------------------------|
|                             | °C          | °F    | %     |                            |
| Onions                      | 0-5         | 32-41 | 65-70 | 6-8 months                 |
|                             | 28-30       | 82-86 | 65-70 | 1 month                    |
| Garlic                      | 0           | 32    | 70    | 6-7 months                 |
|                             | 28-30       | 82-86 | 70    | 1 month                    |
| Dried fruits and vegetables | <10         | <50   | 55-60 | 6-12 months                |

Source: Cantwell, M.I. and Kasmire, R.F. 2002. Postharvest Handling Systems: Underground Vegetables (Roots, Tubers, and Bulbs) p. 435-443. In: A.A. Kader (ed.) Postharvest technology of horticultural crops, University of California. ANR Publication 3311.

For bulk storage of onions or garlic, ventilation systems should be designed to provide air into the store from the bottom of the room at a rate of 2 cubic feet per minute per cubic foot of produce (2 cubic meters per minute per cubic meter of produce). If produce is in cartons or bins, stacks must allow free movement of air. Rows of containers should be stacked parallel to the direction of the flow of air and be spaced six to seven inches apart. An adequate air supply must be provided at the bottom of each row and containers must be properly vented.

**Bulk storage:**

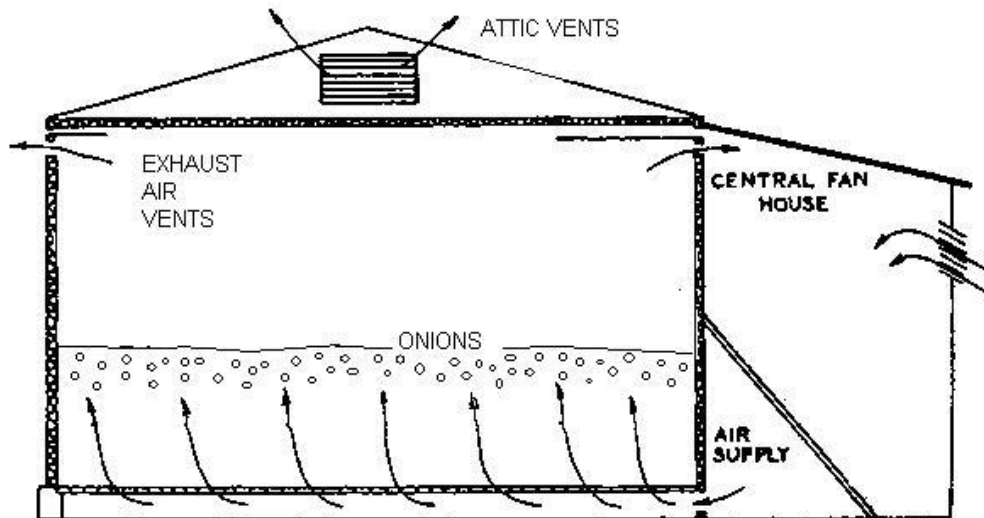

**Storage in cartons or bins:**

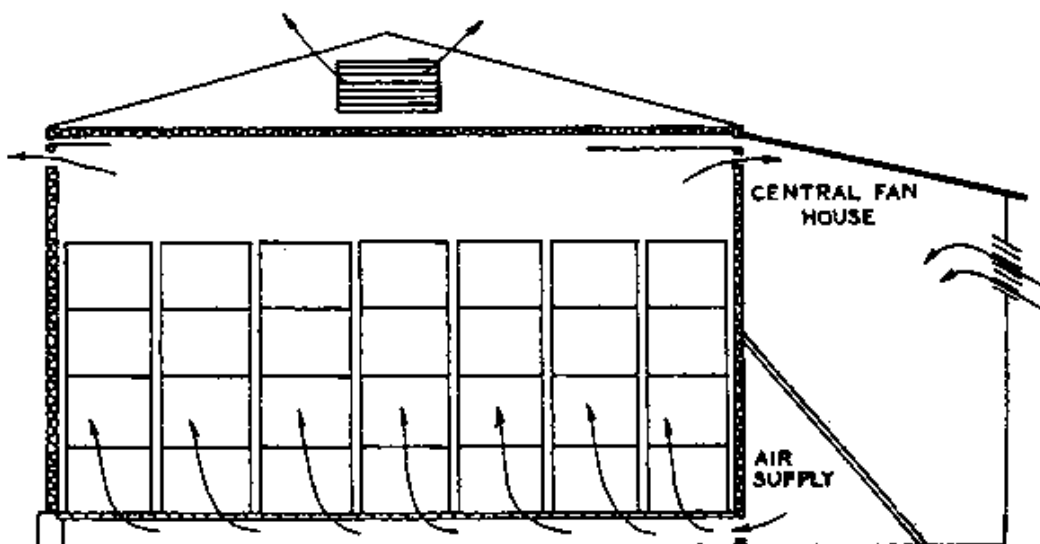

Source: Oregon State University, 1978. Onion Storage: Guidelines for Commercial Growers. Oregon State Extension Service. Extension Circular 948.

## Storage of Root and Tuber Crops

The recommended storage conditions for root and tuber crops are listed in the following table. Potatoes for processing are best kept at intermediate temperatures to limit the production of sugars which darken when heated during processing. Potatoes meant for consumption must also be stored in the dark, since the tubers will produce chlorophyll (turning green) and develop the toxic alkaloid solanine if kept in the light. Potatoes stored for use as "seed" are best stored in diffuse light (CIP, 1981). The chlorophyll and solanine that accumulate will aid to protect the seed potatoes from insect pests and decay organisms.

Tropical root and tuber crops must be stored at temperatures that will protect the crops from chilling, since chilling injury can cause internal browning, surface pitting and increased susceptibility to decay.

|               | Temperature |       | RH       | Potential storage duration |
|---------------|-------------|-------|----------|----------------------------|
|               | °C          | °F    | %        |                            |
| Potatoes      |             |       |          |                            |
| Fresh market  | 4-7         | 39-45 | 95-98    | 10 months                  |
| Processing    | 8-12        | 47-54 | 95-98    | 10 months                  |
| Seed potatoes | 0-2         | 32-36 | 95-98    | 10 months                  |
|               |             |       |          |                            |
| Cassava       | 5-8         | 41-46 | 80-90    | 2-4 weeks                  |
|               | 0-5         | 32-41 | 85-95    | 6 months                   |
| Sweet potato  | 12-14       | 54-57 | 85-90    | 6 months                   |
| Yam           | 13-15       | 55-59 | near 100 | 6 months                   |
|               | 27-30       | 80-86 | 60-70    | 3-5 weeks                  |
| Ginger        | 12-14       | 54-57 | 65-75    | 6 months                   |
| Jicama        | 12-15       | 54-59 | 65-75    | 3 months                   |
| Taro          | 13-15       | 55-59 | 85-90    | 4 months                   |

Source: Cantwell, M.I. and R.F. Kasmire. 2002. Postharvest Handling Systems: Underground Vegetables (Roots, Tubers, and Bulbs) p. 435-443. In: A.A. Kader (ed.) Postharvest technology of horticultural crops, University of California. ANR Publication 3311.



## Storage of Potatoes

When storing potatoes, a field storage clamp is a low-cost technology that can be designed using locally available materials for ventilation and insulation. The example illustrated below employs a wooden ventilator box and straw for insulation. The entire pile of potatoes and straw is covered with a layer of soil, which should not be highly compacted. To reduce heat gain, locate the field clamp in the shade (under a tree, on the cool side of a building, or under a tarp shade.)

In very cold regions, a second layer of straw and soil can be added. In hot regions, less soil is needed, but more ventilation can be added by constructing chimney type air outlets at the top of the clamp.

### Field storage clamp:

Field storage clamp:

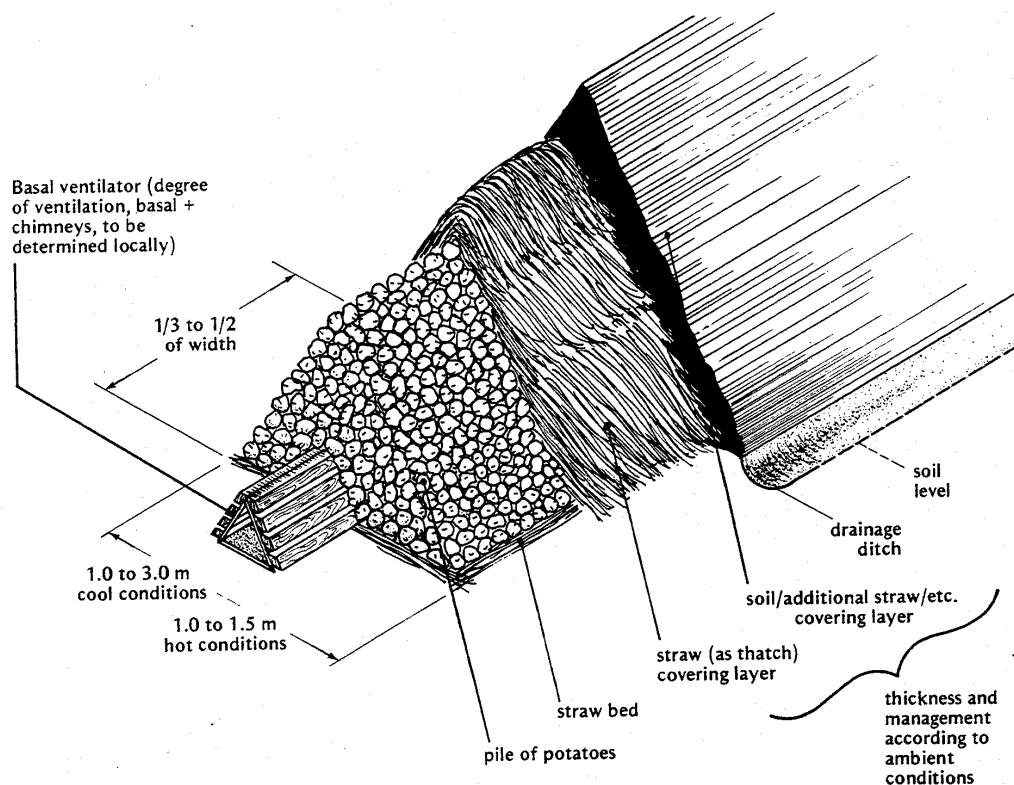

Source: CIP. 1981. Principles of Potato Storage. Lima, Peru: International Potato Center (CIP). p. 105.

Simple storage houses for potatoes can be constructed for small quantities of produce. The examples provided here can store 1 to 2 metric tons, and are used on farms and in mountain villages. The first is made from unfinished wooden planks painted white to reduce heat accumulation from the sun and covered with a large thatched roof for protection from sun and rain. It has a large door on one side for loading and unloading.



The second storage house is constructed from lath and plaster and mud bricks in a cylindrical form. It has two doors, one on top for loading, and another at the bottom for easy removal of potatoes for sale or consumption. White-washing helps reduce heat accumulation and a thatch roof protects the potatoes from rain and sun.

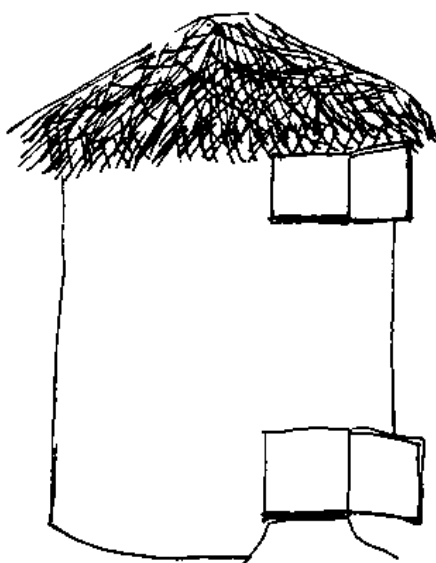

Source: CIP. 1981. Principles of Potato Storage. Lima, Peru: International Potato Center (CIP). p. 105.

For large quantities of potatoes, a self-supporting A-frame storehouse can be constructed. A pit is dug about 10 feet (3 meters) deep and wooden air ducts are placed along the earthen floor. The roof of the building is constructed of wood, and then covered with straw bales and a thick layer of soil.

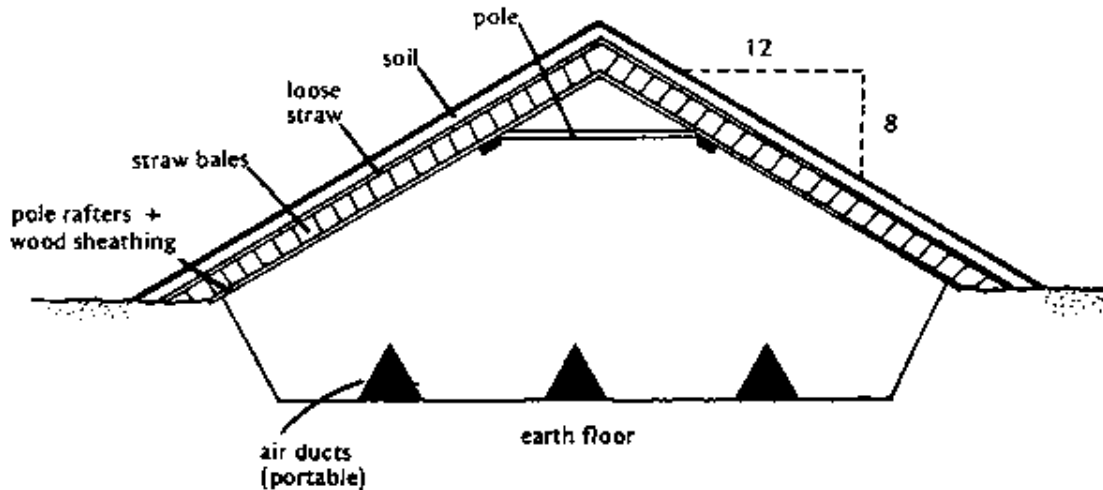

Source: University of Idaho. (n.d.). Idaho Potato Storage. Agricultural Experiment Station, College of Agriculture, Bulletin 410.

Ducts for ventilation of bulk storage rooms can be laid out vertically as well as horizontally. The storeroom for potatoes shown below provides for plenty of ventilation using simple materials. The room can be of any size or shape since air ducts can be positioned to extend evenly throughout.

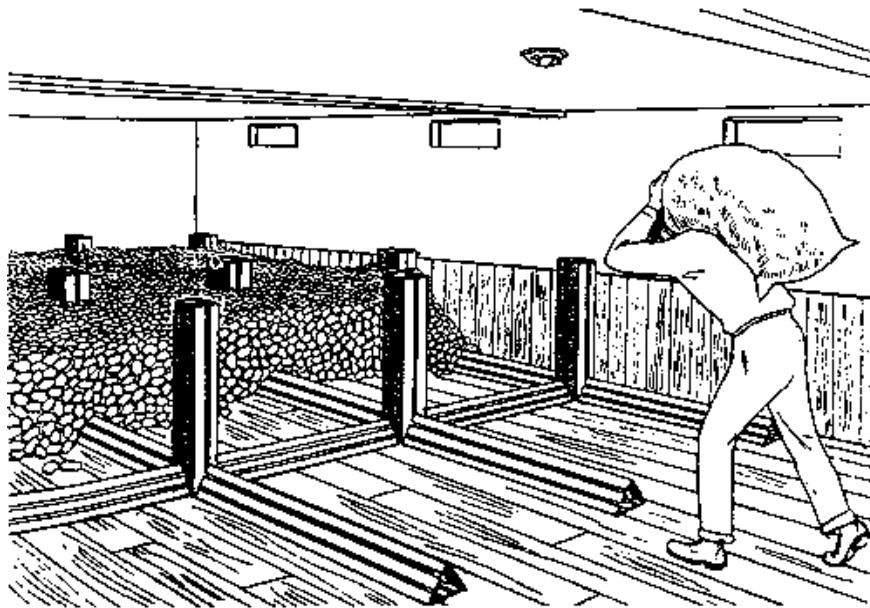

Source: Lopez, E.G. 1983. Conservación de la Producción Agrícola. Barcelona: Editorial Aedos. p. 188.

When loading potatoes into bulk storage, even distribution of the produce is important for proper ventilation. Uneven loads will inhibit air movement and result in storage losses due to inadequate ventilation.

**Even distribution of potatoes in the storeroom:**

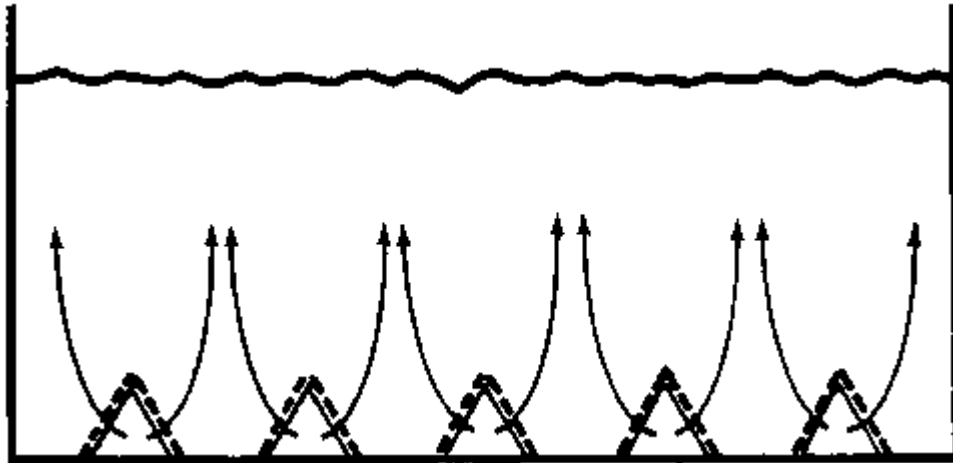

**Uneven distribution of potatoes in the storeroom:**

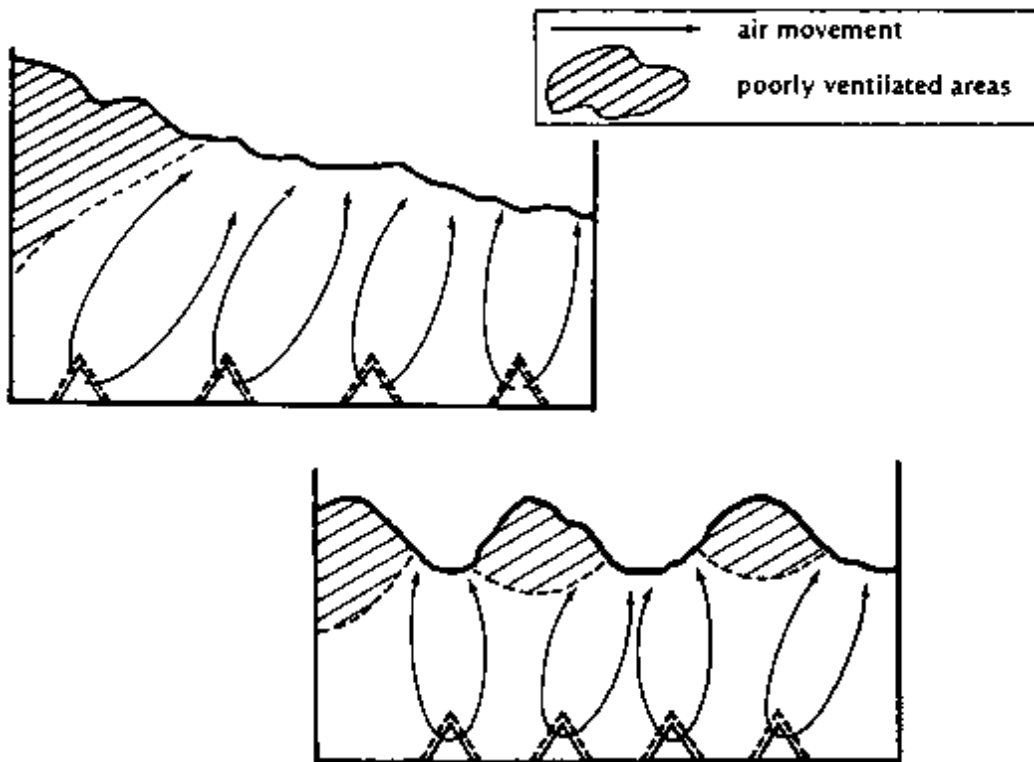

Source: CIP. 1981. Principles of Potato Storage. Lima, Peru: International Potato Center (CIP) p. 105.

## Controlled Atmosphere (CA) Storage

Controlled or modified atmosphere storage should be used as a supplement to, and not as a substitute for, proper temperature and relative humidity management. Some simple methods for modifying the composition of air in the storage environment are listed below (from Kader, 2002). Air coming into the storeroom or being re-circulated within the room must pass through a monitoring and control system.

Oxygen gas control:

To DECREASE:

- purging with nitrogen
- from liquid nitrogen through an evaporator
- from a membrane system nitrogen generator
- from a molecular sieve system nitrogen generator

Carbon dioxide control:

To INCREASE:

- dry ice
- pressurized gas cylinder

To DECREASE:

- molecular sieve scrubber
- activated charcoal scrubber
- sodium hydroxide scrubber
- hydrated lime (use 0.6 kg of hydrated lime to treat the air used to ventilate 100 kg of fruit. Air can be directed to pass through a box, located inside or outside the CA storeroom).

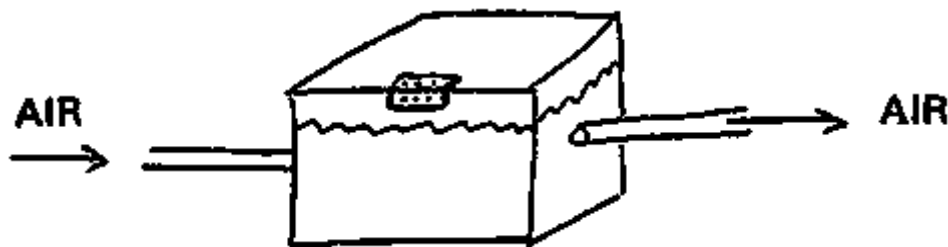

Source: Vigneault, C., Raghavan, V.G.S., and R. Prange. 1994. Techniques for controlled atmosphere storage of fruits and vegetables. Research Branch, Agriculture and Agri-Food Canada, Technical Bulletin 1993-18E.

To regulate CO<sub>2</sub> levels in a CA room, one of the simplest methods is the hydrated lime (Calcium carbonate) Ca(OH)<sub>2</sub> “scrubber”. The scrubber is constructed using an insulated and airtight plywood box located outside the CA room. The box should contain enough lime for the entire storage period, but new lime can be added if CO<sub>2</sub> absorption drops.

The CO<sub>2</sub> and hydrated lime reacts in a 1:1 ratio to form limestone and water. Lime with a smaller particle size (fine mesh) is more efficient at reacting with CO<sub>2</sub> than lime with a coarse mesh. The following will maximize the effectiveness of your small-scale scrubber:

- Lime should be packaged in 25 kg bags that have no polyethylene liner.
- Each bag should be only partially filled (50%) to avoid the outer layer hardening and reducing efficiency over time.
- Lime bags should be stacked on a pallet equipped with shelves that allow a 10 cm space between layers to maximize air circulation.
- Fifty percent of the recommended lime for the anticipated storage period can be placed on pallets on the floor of the storage room (this will consume the initially high CO<sub>2</sub> produced by the fruit).

To keep CO<sub>2</sub> below 2 percent, about 12 kg of lime per metric tons of apples is recommended for 3 to 4 months of storage.

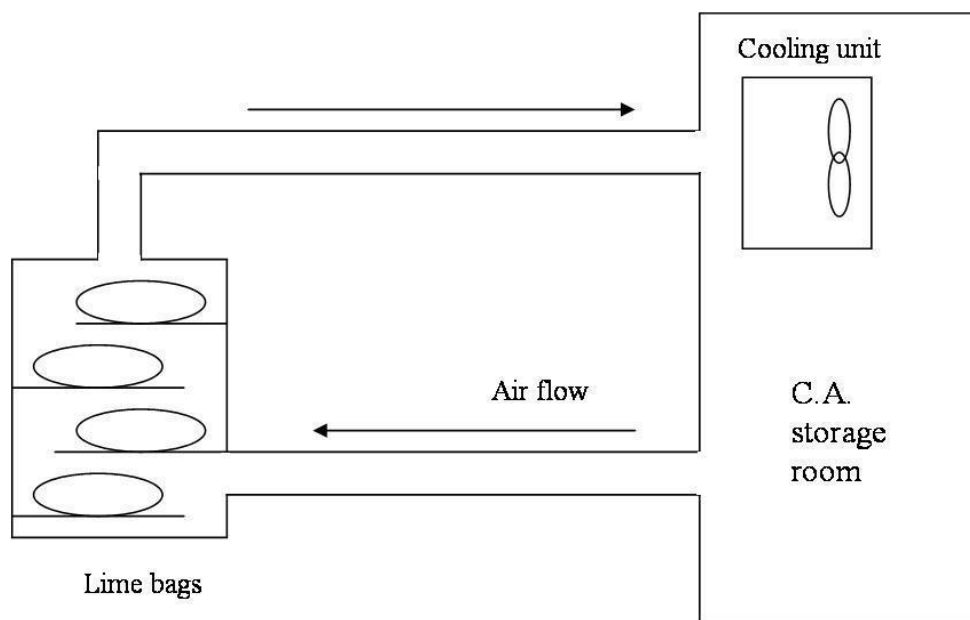

Source: Vigneault, C. et al. 1994. Techniques for controlled atmosphere storage of fruits and vegetables. Research Branch Agriculture and Agri-Food Canada.

## Removing Ethylene

For preventing the buildup of ethylene, a commercial filter can be added to the existing air flow system, or a simple “scrubber” can be constructed and added to the air supply line.

Ethylene control:

To DECREASE:

- potassium permanganate ( $\text{KMnO}_4$ )
- activated charcoal
- catalytic oxidation

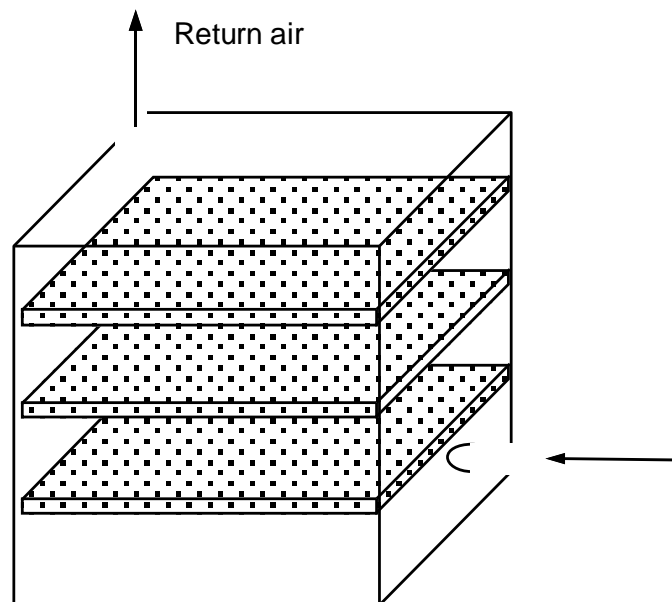

**ETHYLENE SCRUBBER:** place Purafil<sup>®</sup> pellets ( $\text{KMnO}_4$ ) in shallow layers on screen trays sealed inside a solid wooden box. Air must flow through 3 or 4 trays of pellets for successful removal of ethylene gas.

Extend-A-Life filters can be added to your existing cooling system. They are effective, inexpensive, and easy to install. To learn more:  
<http://www.agraconew.com/products/ethylene-filters/>

Controlled atmosphere storage of pallet loads of produce is also possible using a semi-permanent set-up for creating a gas-seal. Any number of pallets can be accommodated inside a plastic tent made using 7 to 8 mm. polyethylene sheeting. A better gas barrier at the floor (compared with the traditional tube in trough method illustrated below) can be obtained by laying a sheet of 4 to 5 mm. polyethylene on the floor and covering it with wood panels. The seal is then made by joining the tent plastic with the floor plastic (using tape).

Typical layout of a C.A. tent:

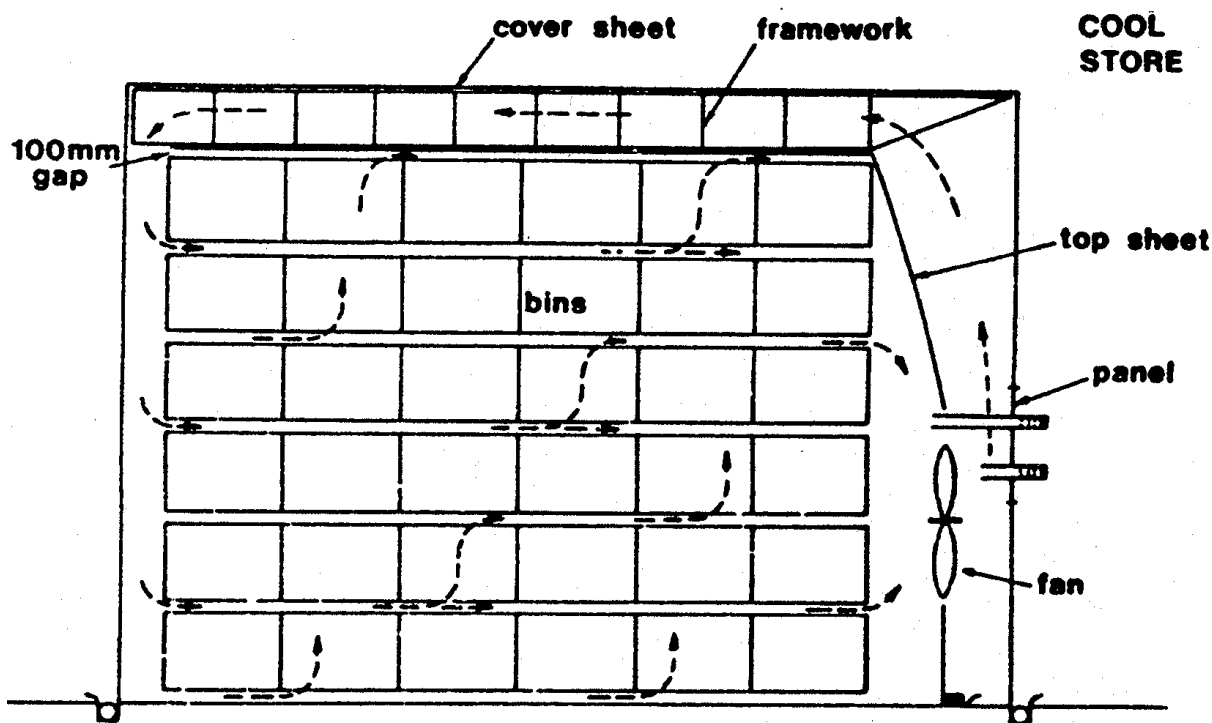

Source: McDonald, B. 1982. Controlled atmosphere storage using plastic tents. International Institute of Refrigeration.



Another simple practice that can be used to store produce under controlled atmosphere conditions involves constructing plastic tents using 20 mm. polyvinylchloride (PVC) sheeting suspended over traditional pallet racks inside a refrigerated cold storage warehouse. The diagram below shows two C.A. tents. The top tent has been sealed by closing zippers on both sides of the door and immersing the bottom of the door and adjacent floor panel in a trough of water. The trough is made using a 6-inch diameter PVC pipe (with 1/3 of the pipe cut away), which also allows supply and sampling gas lines and temperature probe wiring to pass into the tent. All seams and joints of the tents are heat-welded.

The bottom tent is shown with the door rolled open and one pallet load of produce loaded into the tent.

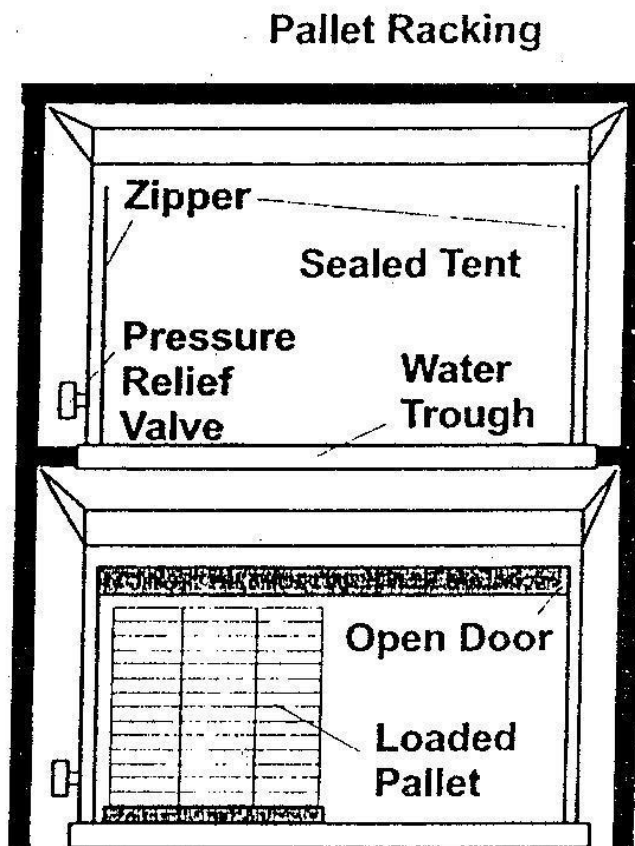

Source: Leyte, J.C. and Forney, C.F. 1999. Controlled atmosphere tents for storing fresh produce in conventional refrigerated rooms. HortTechnology 9 (4) 672-675.

A low-cost plastic tent fashioned from clear polyethylene sheeting can be used for controlled atmosphere storage of bunches of green bananas. A small fan serves to circulate the C.A. storage air (2% O<sub>2</sub> and 5% CO<sub>2</sub>) through a chamber of potassium permanganate (KMnO<sub>4</sub>) on aluminum oxide (Al<sub>2</sub>O<sub>3</sub>) (Purafil). Ripening is delayed as ethylene is scrubbed from the storage air. The shelf life of bananas under these conditions is four to six weeks at ambient temperatures.

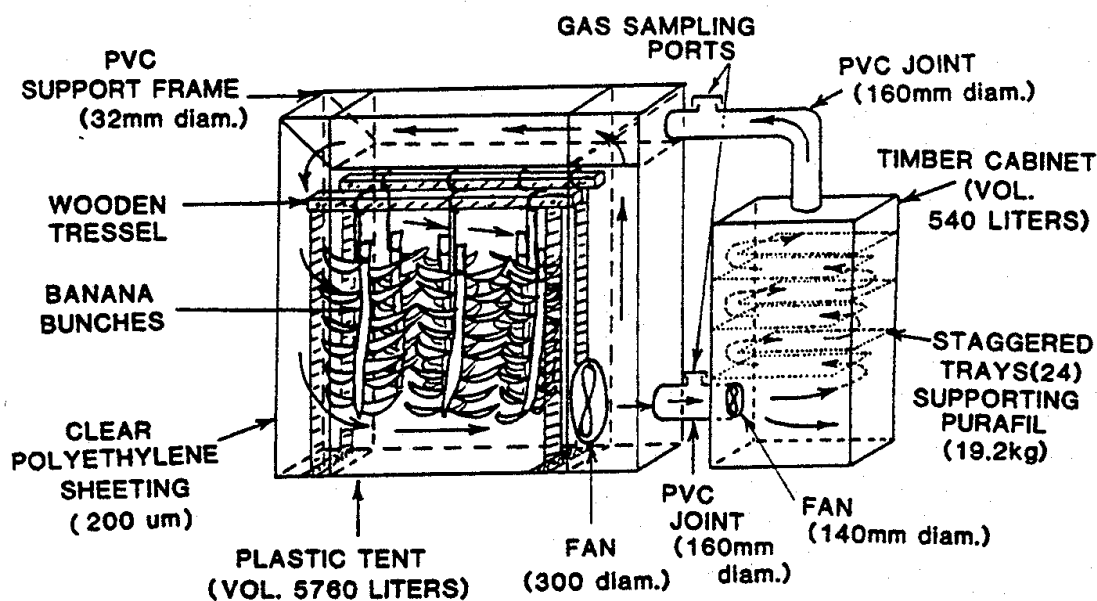

Source: Shorter, A.J. et al. 1987. Controlled atmosphere storage of bananas in bunches at ambient temperatures. CSIRO Food Research Quarterly 47:61-63.

The following tables are a summary of controlled atmosphere (CA) and modified atmosphere (MA) requirements and recommendations.

A summary of controlled atmosphere (CA) and modified atmosphere (MA) requirements and recommendations for apples

Average optimum levels of popular apple varieties.

| Cultivar         | O <sub>2</sub><br>% | CO <sub>2</sub><br>(%) | Temp.<br>(°C) | Storage<br>(Month) |
|------------------|---------------------|------------------------|---------------|--------------------|
| Braeburn         | 1.8                 | 1.0                    | 0.7           | 6-9                |
| Fuji             | 1.4                 | 1.0                    | 0.3           | 7-11               |
| Gala             | 1.7                 | 1.6                    | 1.3           | 2-9                |
| Golden Delicious | 1.6                 | 2.3                    | 0.5           | 7-11               |
| Granny Smith     | 1.4                 | 2.0                    | 0.6           | 7-11               |
| Idared           | 2.1                 | 2.5                    | 1.9           | 7-10               |
| Jonagold         | 1.4                 | 2.7                    | 0.9           | 5-10               |
| McIntosh         | 2.1                 | 2.9                    | 2.5           | 5-10               |
| Red Delicious    | 1.6                 | 1.8                    | 0.0           | 6-11               |
| Royal Gala       | 1.7                 | 1.8                    | -0.2          | 5-8                |
| Average          | 1.7                 | 2.0                    | 0.9           |                    |

Source: Kupferman, E. 1997. Controlled atmosphere storage of apples. CA '97 Proceedings, Vol. 2, p.1-30. Postharvest Horticulture Series No. 16, University of California, Davis.

## Summary of controlled atmosphere (CA) and modified atmosphere (MA) requirement and recommendations for pears

Optimum storage temperature is  $-1$  to  $0$  °C, unless otherwise indicated. (CA-disorder abbreviations are: IB=internal breakdown or browning; BH=brown heart; PBC=pithy brown core; CF=core flush; Cav=cavity, usually lense shaped; CI=chilling injury).

| Variety                                  | O <sub>2</sub><br>% | CO <sub>2</sub><br>(%) | Storage<br>Month | CA-<br>Disorders |
|--|---------------------|------------------------|------------------|------------------|
| Abate Fetel                              | 1                   | 1                      | 5-6              | IB               |
| Alejandrina                              | 3                   | 2                      | 4-5              | IB               |
| Anjou, d'Anjou                           | 1-2.5               | 0-0.5                  | 7-8              | IB,PBC,Cav       |
| Bartlett<br>(=William's Bon Chretien)    | 1-2                 | 0-0.5                  | 3-5              | CF,PBC           |
| Blanquilla,<br>(=Blanca de Aranjuez)     | 3                   | 3                      | 6-7              |                  |
| Bosc, Kaiser                             | 1-2.5               | 0.5-1.5                | 4-8              | PBC, Cav         |
| Buena Luisa<br>(=Buona Luisa)            | 3                   | 2                      | 6                | IB, CF           |
| Clapp's Favorite                         | 2                   | <0.7                   | 3-4              | IB, PBC          |
| Comice<br>(=Doyenne du Comice, Comizio)  | 1.5-4               | 0.5-4                  | 5-6              | IB(overmature)   |
| Conference                               | 1-2.5               | 0.6-1.5                | 6-8              | BH,IB, Cav       |
| Coscia                                   | 1.5                 | 2-3                    | 6-7              | CF               |
| Flor d'Hivern(=Inverno)                  | 3                   | 3                      | 4-5              | IB               |
| Forelle                                  | 1.5                 | 0-1.5                  | 6-7              |                  |
| General Leclerc                          | 2-3                 | 2-3                    | 3-5              |                  |
| Grand Champion                           | 3                   | 2-2.5                  | 4                |                  |
| Hardy                                    | 2-3                 | 3-5                    | 4-6              |                  |
| Josephine                                | 1-2                 | 1-2                    | 8                |                  |
| Krystalli                                | 2                   | 1-2                    | 3-5              |                  |
| Limonera, Llimonera                      | 3                   | 3                      | 3-4              |                  |
| Packham's Triumph                        | 1.5-1.8             | 1.5-2.5                | 7-9              | CB               |
| Passe Crassane<br>(=Passa Crassana)      | 3                   | 4-5                    | 5-8              | IB               |
| Rocha                                    | 2                   | 2                      | 8                |                  |
| Spadona                                  | 1.5-2.5             | 1.5-3.5                | 8-9              | IB               |
| <b>Nashi, Asian pears:</b>               |                     |                        |                  |                  |
| Chojuro                                  | 2                   | 1-2                    | 3-4              |                  |
| Kosui                                    | 1-2                 | 0-2                    | 3-4              |                  |
| Nijiseiki<br>(=20 <sup>th</sup> Century) | 0.5-3               | 0-1                    | 5                |                  |
| Tsu Li                                   | 1-2                 | 0-3                    | 3-5              | IB               |
| Ya Li                                    | 4-5                 | 0-4                    | 3-4              | IB, Cav, CI?     |

'Ya Li' may show a type of chill injury at temperatures  $<5$ °C.

Source: Richardson, D.G. and E. Kupferman. 1997. Controlled atmosphere storage of pears. CA '97 Proceedings, Vol. 2, p. 31-35. Postharvest Horticulture Series No. 16, University of California, Davis.

## A summary of CA requirements and recommendations for fruits other than apples and pears

| Commodity           | Temperature Range <sup>1</sup> (°C) | CA <sup>2</sup>  |                   | Commercial use as of June, 2001   |
|---------------------|-------------------------------------|------------------|-------------------|---|
|                     |                                     | % O <sub>2</sub> | % CO <sub>2</sub> |   |
| Apricot             | 0-5                                 | 2-3              | 2-3               |   |
| Asian pear          | 0-5                                 | 2-4              | 0-1               | Limited use on some cultivars   |
| Avocado             | 5-13                                | 2-5              | 3-10              | Used during marine transport  |
| Banana              | 12-16                               | 2-5              | 2-5               | Used during marine transport  |
| Blackberry          | 0-5                                 | 5-10             | 15-20             | Used within pallet covers during transport  |
| Blueberry           | 0-5                                 | 2-5              | 12-20             | Limited use during transport  |
| Cactus pear         | 5-10                                | 2-3              | 2-5               |   |
| Cherimoya & Atemoya | 8-15                                | 3-5              | 5-10              |   |
| Cherry, sweet       | 0-5                                 | 3-10             | 10-15             | Used within pallet covers or marine containers during transport   |
| Cranberry           | 2-5                                 | 1-2              | 0-5               |   |
| Durian              | 12-20                               | 3-5              | 5-15              |   |
| Fig                 | 0-5                                 | 5-10             | 15-20             | Limited use during transport  |
| Grape               | 0-5                                 | 2-5              | 1-3               | Incompatible with SO <sub>2</sub> fumigation  |
|                     |                                     | 5-10             | 15-20             | Limited use instead of SO <sub>2</sub> for decay control during transport up to 4 weeks                   |
| Grapefruit          | 10-15                               | 3-10             | 5-10              |   |
| Guava               | 5-15                                | 2-5              | 0-1               |   |
| Kiwifruit           | 0-5                                 | 1-2              | 3-5               | Expanding use during transport and storage; C <sub>2</sub> H <sub>4</sub> must be maintained below 20 ppb |
| Lemon               | 10-15                               | 5-10             | 0-10              |   |
| Lime                | 10-15                               | 5-10             | 0-10              |   |
| Loquat              | 0-5                                 | 2-4              | 0-1               |   |
| Lychee (litchi)     | 5-12                                | 3-5              | 3-5               |   |
| Mango               | 10-15                               | 3-7              | 5-8               | Increasing use during marine transport  |
| Nectarine           | 0-5                                 | 1-2              | 3-5               | Limited use during marine transport   |

| Commodity                | Temperature Range <sup>1</sup> (°C) | CA <sup>2</sup>  |                   | Commercial use as of June, 2001   |
|--------------------------|-------------------------------------|------------------|-------------------|---|
|                          |                                     | % O <sub>2</sub> | % CO <sub>2</sub> |   |
|                          |                                     | or               |                   |   |
|                          |                                     | 4-6              | 15-17             | Used to reduce chilling injury (internal breakdown) of some cultivars                           |
| Olive                    | 5-10                                | 2-3              | 0-1               | Limited use to extend processing season   |
| Orange                   | 5-10                                | 5-10             | 0-5               |   |
| Papaya                   | 10-15                               | 2-5              | 5-8               |   |
| Peach, clingstone        | 0-5                                 | 1-2              | 3-5               | Limited use to extend canning season  |
| Peach, freestone         | 0-5                                 | 1-2<br>or        | 3-5               | Limited use during marine transport   |
|                          |                                     | 4-6              | 15-17             | Used to reduce incidence and severity of internal breakdown (chilling injury) of some cultivars |
| Persimmon                | 0-5                                 | 3-5              | 5-8               | Limited use of MA packaging   |
| Pineapple                | 8-13                                | 2-5              | 5-10              | Waxing is used to create MA and reduce endogenous brown spot                                    |
| Plum                     | 0-5                                 | 1-2              | 0-5               | Limited use for long-term storage of some cultivars   |
| Pomegranate              | 5-10                                | 3-5              | 10-15             |   |
| Rambutan                 | 8-15                                | 3-5              | 7-12              |   |
| Raspberry                | 0-5                                 | 5-10             | 15-20             | Used within pallet covers during transport  |
| Strawberry               | 0-5                                 | 5-10             | 15-20             | Used within pallet covers during transport  |
| Sweetsop (custard apple) | 12-20                               | 3-5              | 5-10              |   |

<sup>1</sup>Usual and/or recommended range; a relative humidity of 90-95% is recommended.

<sup>2</sup>Specific CA combination depends on cultivar, temperature, and duration of storage. These recommendations are for transport and/or storage beyond 2 weeks. Exposure to lower O<sub>2</sub> and or higher CO<sub>2</sub> concentrations for shorter durations may be used for control of some physiological disorders, pathogen, and/or insects.

Source: Kader, A.A. 2001. A summary of CA requirements and recommendations for fruits other than apples and pears. p. 29-70. Postharvest Horticulture Series No. 22A, University of California, Davis.

## A summary of CA requirements and recommendations for 34 harvested vegetables

| Vegetable <sup>3</sup> | Temperature <sup>1</sup> |         | Atmosphere <sup>2</sup> |                   | Application <sup>3</sup> |
|------------------------|--------------------------|---------|-------------------------|-------------------|--------------------------|
|                        | Optimum                  | Range   | % O <sub>2</sub>        | % CO <sub>2</sub> |                          |
| Artichokes             | 0                        | 0 - 5   | 2 - 3                   | 2 - 3             | ++                       |
| Asparagus              | 2                        | 1 - 5   | Air                     | 10 -14            | +++                      |
| Beans, green snap      | 8                        | 5 - 10  | 1 - 3                   | 3 - 7             | +                        |
| processing             | 8                        | 5 - 10  | 8 -10                   | 20 -30            | ++                       |
| Broccoli               | 0                        | 0 - 5   | 1 - 2                   | 5 -10             | +++                      |
| Brussels sprouts       | 0                        | 0 - 5   | 1 - 2                   | 5 - 7             | +                        |
| Cabbage                | 0                        | 0 - 5   | 2 - 3                   | 3 - 6             | +++                      |
| Chinese cabbage        | 0                        | 0 - 5   | 1 - 2                   | 0 - 5             | +                        |
| Cantaloupes            | 3                        | 2 - 7   | 3 - 5                   | 10 -20            | ++                       |
| Cauliflower            | 0                        | 0 - 5   | 2 - 3                   | 3 - 4             | +                        |
| Celeriac               | 0                        | 0 - 5   | 2 - 4                   | 2 - 3             | +                        |
| Celery                 | 0                        | 0 - 5   | 1 - 4                   | 3 - 5             | +                        |
| Cucumbers, fresh       | 12                       | 8 - 12  | 1 - 4                   | 0                 | +                        |
| pickling               | 4                        | 1 - 4   | 3 - 5                   | 3 - 5             | +                        |
| Herbs <sup>4</sup>     | 1                        | 0 - 5   | 5 -10                   | 4 - 6             | ++                       |
| Leeks                  | 0                        | 0 - 5   | 1 - 2                   | 2 - 5             | +                        |
| Lettuce (crisphead)    | 0                        | 0 - 5   | 1 - 3                   | 0                 | ++                       |
| cut or shredded        | 0                        | 0 - 5   | 1 - 5                   | 5 -20             | +++                      |
| Lettuce (leaf)         | 0                        | 0 - 5   | 1 - 3                   | 0                 | ++                       |
| Mushrooms              | 0                        | 0 - 5   | 3 -21                   | 5 -15             | ++                       |
| Okra                   | 10                       | 7 - 12  | Air                     | 4 -10             | +                        |
| Onions (bulb)          | 0                        | 0 - 5   | 1 - 2                   | 0 -10             | +                        |
| Onions (bunching)      | 0                        | 0 - 5   | 2 - 3                   | 0 - 5             | +                        |
| Parsley                | 0                        | 0 - 5   | 8 -10                   | 8 -10             | +                        |
| Pepper (bell)          | 8                        | 5 - 12  | 2 - 5                   | 2 - 5             | +                        |
| Pepper (chili)         | 8                        | 5 - 12  | 3 - 5                   | 0 - 5             | +                        |
| processing             | 5                        | 5 - 10  | 3 - 5                   | 10 -20            | ++                       |
| Radish (topped)        | 0                        | 0 - 5   | 1 - 2                   | 2 - 3             | +                        |
| Spinach                | 0                        | 0 - 5   | 7 -10                   | 5 -10             | +                        |
| Sugar peas             | 0                        | 0 - 10  | 2 - 3                   | 2 - 3             | +                        |
| Sweet corn             | 0                        | 0 - 5   | 2 - 4                   | 5 -10             | +                        |
| Tomatoes (green)       | 12                       | 12 - 20 | 3 - 5                   | 2 - 3             | +                        |
| ripe                   | 10                       | 10 - 15 | 3 -5 3                  | -5++              |                          |
| Witloof chicory        | 0                        | 0 - 5   | 3 - 4                   | 4 - 5             | +                        |

<sup>1</sup> Optimum and range of usual and/or recommended temperatures. A relative humidity of 90% to 95% is usually recommended (except for bulb onions).

<sup>2</sup> Specific CA recommendations depend on cultivar, temperature, and duration of storage.

<sup>3</sup> Potential for application can be high (+++), moderate (++), or slight (+).

<sup>4</sup> Herbs: chervil, chives, coriander, dill, sorrel and watercress.

Source: Saltveit, M.A. 2001. A summary of CA requirements and recommendations for vegetables. p. 71-94. Postharvest Horticulture Series No. 22A, University of California, Davis.

## A summary of CA and MA recommendations for selected fresh-cut fruits and vegetables

James R. Gorny  
International Fresh-cut Produce Association  
Davis, CA 95616 USA

Table 1. Fresh-cut Vegetables

| Fresh-Cut Product                         | Temperature (°C) | Atmosphere       |                   | Efficacy           |
|---|------------------|------------------|-------------------|--------------------|
|   |                  | % O <sub>2</sub> | % CO <sub>2</sub> |                    |
| Beets (Red), Grated, Cubed,<br>or Peeled  | 0-5              | 5                | 5                 | Moderate           |
| Broccoli, Florets                         | 0-5              | 2-3              | 6-7               | Good               |
| Cabbage, Shredded                         | 0-5              | 5-7.5            | 15                | Good               |
| Cabbage (Chinese), Shredded               | 0-5              | 5                | 5                 | Moderate           |
| Carrots, Shredded, Sticks, or<br>Sliced   | 0-5              | 2-5              | 15-20             | Good               |
| Jicama, Sticks                            | 0-5              | 5                | 5-10              | Good               |
| Leek, Sliced                              | 0-5              | 5                | 5                 | Moderate           |
| Lettuce (Butterhead), Chopped             | 0-5              | 1-3              | 5-10              | Moderate           |
| Lettuce (Green Leaf), Chopped             | 0-5              | 0.5-3            | 5-10              | Good               |
| Lettuce (Iceberg), Chopped<br>or Shredded | 0-5              | 0.5-3            | 10-15             | Good               |
| Lettuce (Red Leaf), Chopped               | 0-5              | 0.5-3            | 5-10              | Good               |
| Lettuce (Romaine), Chopped                | 0-5              | 0.5-3            | 5-10              | Good               |
| Mushrooms, Sliced                         | 0-5              | 3                | 10                | NOT<br>RECOMMENDED |
| Onion, Sliced or Diced                    | 0-5              | 2-5              | 10-15             | Good               |
| Peppers, Diced                            | 0-5              | 3                | 5-10              | Moderate           |
| Potato, Sliced or Whole-Peeled            | 0-5              | 1-3              | 6-9               | Good               |
| Pumpkin, Cubed                            | 0-5              | 2                | 15                | Moderate           |



|                  |     |        |      |          |
|------------------|-----|--------|------|----------|
| Rutabaga, Sliced | 0-5 | 5      | 5    | Moderate |
| Spinach, Cleaned | 0-5 | 0.8-3  | 8-10 | Moderate |
| Tomato, Sliced   | 0-5 | 3      | 3    | Moderate |
| Zucchini, Sliced | 5   | 0.25-1 | -    | Moderate |

Table 2. Fresh-cut Fruit

| Fresh-Cut Product  | Temperature (°C) | Atmosphere       |                   | Efficacy |
|--------------------|------------------|------------------|-------------------|----------|
|                    |                  | % O <sub>2</sub> | % CO <sub>2</sub> |          |
| Apple, Sliced      | 0-5              | <1               | 4-12              | Moderate |
| Cantaloupe, Cubed  | 0-5              | 3-5              | 6-15              | Good     |
| Grapefruit, Slices | 0-5              | 14-21            | 7-10              | Moderate |
| Honeydew, Cubed    | 0-5              | 2                | 10                | Good     |
| Kiwifruit, Sliced  | 0-5              | 2-4              | 5-10              | Good     |
| Mango Cubes        | 0-5              | 2-4              | 10                | Good     |
| Orange, Sliced     | 0-5              | 14-21            | 7-10              | Moderate |
| Peach, Sliced      | 0                | 1-2              | 5-12              | Poor     |
| Pear, Sliced       | 0-5              | 0.5              | <10               | Poor     |
| Persimmon, Sliced  | 0-5              | 2                | 12                | Poor     |
| Pomegranate, Arils | 0-5              | -                | 15-20             | Good     |
| Strawberry, Sliced | 0-5              | 1-2              | 5-10              | Good     |
| Watermelon Cubes   | 0-5              | 3-5              | 10                | Good     |

Source: Gorny, J.R. 2001. A summary of CA and MA requirements and recommendations for fresh-cut (minimally processed) fruits and vegetables. p. 95-145. Postharvest Horticulture Series No. 22A, University of California, Davis.

## **Chapter 8: Transportation of Horticultural Crops**

Temperature management is critical during long distance transport. Loads must be stacked to allow proper air circulation to carry away heat from the produce itself as well as incoming heat from the atmosphere and off the road. Transport vehicles should be well-insulated to maintain cool environments for pre-cooled commodities and well-ventilated to allow air movement through the produce. During transport, produce must be stacked in ways that minimize damage, then braced and secured. An open-air vehicle can be loaded in such a way that allows air to pass through the load and provides some cooling of the produce as the vehicle moves. Also, traveling during the night and early morning can reduce the heat load on a vehicle that is transporting produce. Drivers of vehicles used for shipping produce must be trained in how to load and handle their cargoes. There tends to be a large turnover in drivers (in the US the average time on the job is only 3.5 years) so training is a constant concern (Hagen, et al., 1999).

Recent documents report that carrying mixed loads in North America is still a very common practice, especially with vegetable shipments (Hagen et al, 1999). Mixed loads can be a serious concern when temperature optima are not compatible. For example, transporting chilling-sensitive fruits with commodities that require very low temperatures or ethylene-producing commodities with ethylene-sensitive commodities can cause serious damage to the loads. High-ethylene producers (such as ripe bananas, apples, and cantaloupes) can induce physiological disorders and/or undesirable changes in color, flavor and texture in ethylene-sensitive commodities (such as lettuce, cucumbers, carrots, potatoes, and sweet potatoes).

A wide range of pallet covers are available for covering cooled product during handling and transportation. Polyethylene covers are inexpensive and lightweight, and protect pallet loads from dust, moisture and some loss of cold. Lightweight insulated covers can protect the load from heat gain for several hours (for example, during a delay in loading). Heavyweight covers are sometimes used to protect tropical products from the cold when shipped during winter. Visit the internet for more information (keywords: produce pallet covers) or order a catalog from the International Ripening Company ([www.QAsupplies.com](http://www.QAsupplies.com) or 800-472-7205).

## Best Practices For Transport

|         | <b>DO</b>  | <b>DO NOT</b>  |
|---------|--|--|
| General | <p>Stack heavier produce at the bottom of the load to prevent compression damage to produce.</p> <p>Use strong packages (half the stacking strength of a corrugated fiberboard container can be lost during a five-day trip in a high-humidity environment).</p> <p>When stacking containers, be sure to align them properly (most of the strength of a corrugated box is in the corners). A one-inch overhang will decrease stacking strength by 15 to 34%.</p> <p>Prevent vibration damage by using air suspension systems, which will provide a gentler ride during transportation.</p> <p>Using suitable trays, place packing, plastic bags, and container liners, or placing a soft pad at the top of a full box can reduce vibration damage.</p> <p>Make sure the vehicle has adequate ventilation to prevent heat gain during transport.</p> <p>Use a pre-loading checklist to ensure the vehicle is ready to use successfully.</p> | <p>Overload vehicles.</p> <p>Overfill containers (rounded sides or bulge-packing)</p> <p>Handle packages roughly during loading and unloading.</p> |

|                  | <b>DO</b>   | <b>DO NOT</b>  |
|------------------|---|--|
| Open Loads       | <p>Provide a thick layer of insulation and cushioning for bulk loads.</p> <p>Load packaged produce in uniform stacks, braced securely to prevent damage. Construct a wind catcher for moving air into the vehicle during transport.</p> <p>Provide channels for air movement beneath and above through the load (exiting at the rear of the vehicle).</p> <p>Provide shade for the load with a silver or light-colored canvas cover.</p>  | <p>Place other loads on top of a bulk loaded commodity.</p> <p>Stand upon the produce during loading or unloading.</p>   |
| Reefer Transport | <p>Ensure that vehicles are well-insulated and have doors that seal tightly and securely.</p> <p>Run through the check-list for refrigerated transport before handling each load.</p> <p>Look for recommended design features when purchasing new or used transport vehicles.</p> <p>Pre-cool refrigerated vehicles to suit produce requirements.</p> <p>Load only pre-cooled produce into vehicles from a refrigerated dock.</p> <p>Turn off the refrigeration unit while loading from an open dock (leaving the unit on may cause ice to form on the refrigeration coils, blocking air circulation during transport).</p> | <p>Allow delays when loading on an open dock -- delays will cause heat gain, especially if produce is exposed to full sun.</p> <p>Block air flow under or anywhere else in the load.</p> <p>Transport mixed loads if possible; or install ethylene scrubbers to prevent damage to ethylene-sensitive commodities.</p> <p>Transport chilling-sensitive commodities when thermostats are set below 12-15 °C (53- 59 °F).</p> |

|  | <b>DO</b>  | <b>DO NOT</b>  |
|--|--|--|
|  | <p>Use high-quality vented containers and load produce to ensure adequate air movement through the load to remove the heat generated by produce respiration.</p> <p>Monitor the supply air temperature and the return air temperature for obtaining the best performance of refrigeration units.</p> <p>Load produce away from the side walls to prevent heat gain from the external environment.</p> <p>Make sure mixed sizes of containers or un-palletized produce do not block lengthwise air flow.</p> <p>Brace the load at least 5 cm (2") away from the side walls and at least 10 cm (4") away from the rear door.</p> <p>Use a portable temperature recorder to verify temperature management during transport.</p> | <p>Turn off the refrigeration unit during delays in transport.</p> |

## Open Vehicles

Bulk loads of produce should be carefully loaded to prevent mechanical damage. Vehicles can be padded or lined with a thick layer of straw. Woven mats or sacks can also be used in the beds of small vehicles. Other loads should not be placed on top of the bulk commodity.

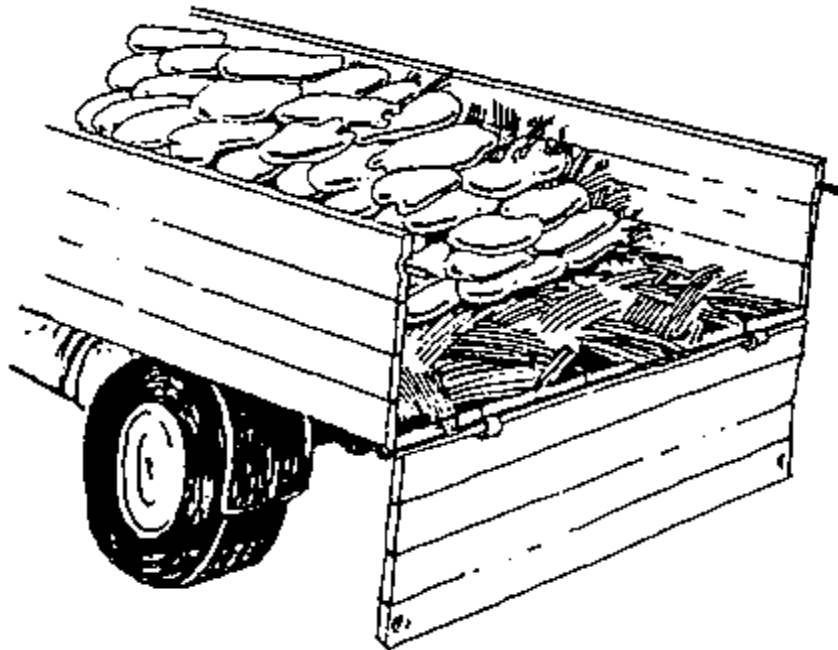

Source: Wilson, J. (n.d.). Careful Storage of Yams: Some Principles to Reduce Losses. London: Commonwealth Secretariat/ International Institute of Tropical Agriculture.

Cooling open loads is desirable whenever possible. A truck ventilating device can be constructed for an un-refrigerated open vehicle by covering the load loosely with canvas and fashioning a wind catcher from sheet metal. The scoop should be mounted at the front of the bed and should reach somewhat higher than the height of the cab. High-transportation speeds and/or long-distance transport run the risk of causing excessive drying of the crop.

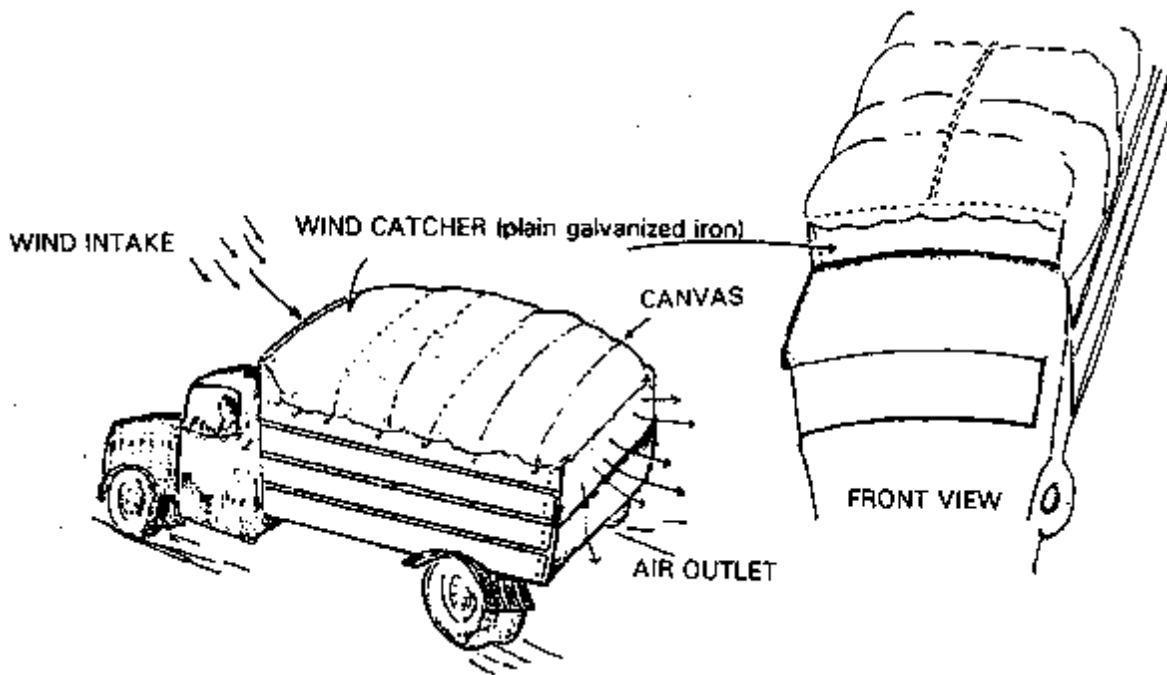

Source: Pantastico, Er. B. 1980. FAO/UNEP Expert Consultation on Reduction of Food Losses in Perishable Products of Plant Origin, Working Document 2: Fruits and Vegetables. (6-9 May, Rome: FAO)

This ventilating system was designed for hauling bulk loads of fresh fava beans in Iran. The wind catcher and ducts were constructed using wooden crates. After removing the end panels, the crates were wired together into the pattern shown below. Air flows upward through the load during transport, which helps to keep the produce from overheating. This system has also been used in pick-up trucks, and for hauling bulk greens and green beans. Best results are obtained when transporting during the early morning hours, before sunrise.

Top View

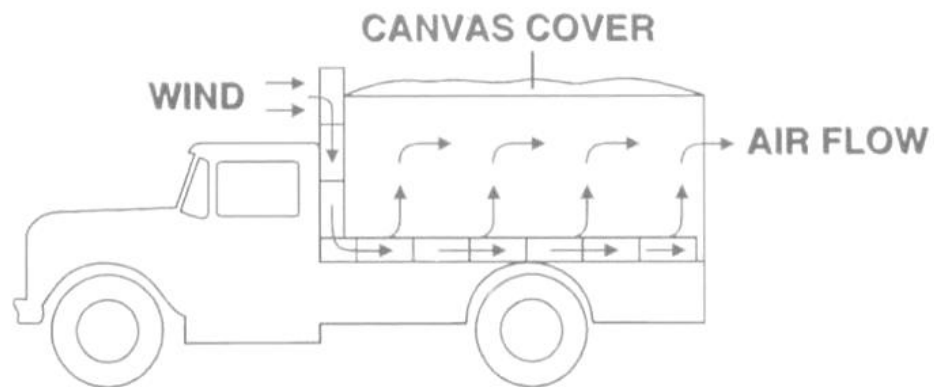
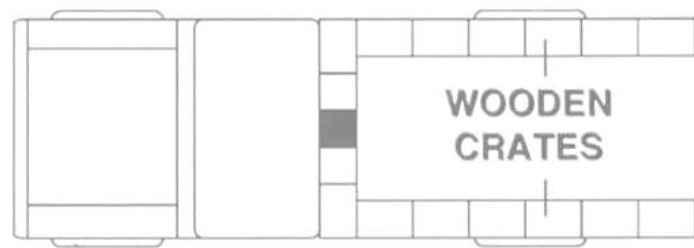

Source: Kasmire, R.F. 1994. Personal Communication.



## USDA Portacooler

The USDA postharvest cooling program stresses the need for small growers to:

- a) sort and grade produce out of the field,
- b) package the produce properly for the market,
- c) immediately cool the produce to remove field heat.

This small cooler uses a 12,000 BTU/hr (1 ton) 110 volt room window air conditioner to cool air inside the insulated box. The cool air inside the front of the box is forced through the produce by a pressure fan in a second wall inside. The return air then passes under a false floor to the front of the box.

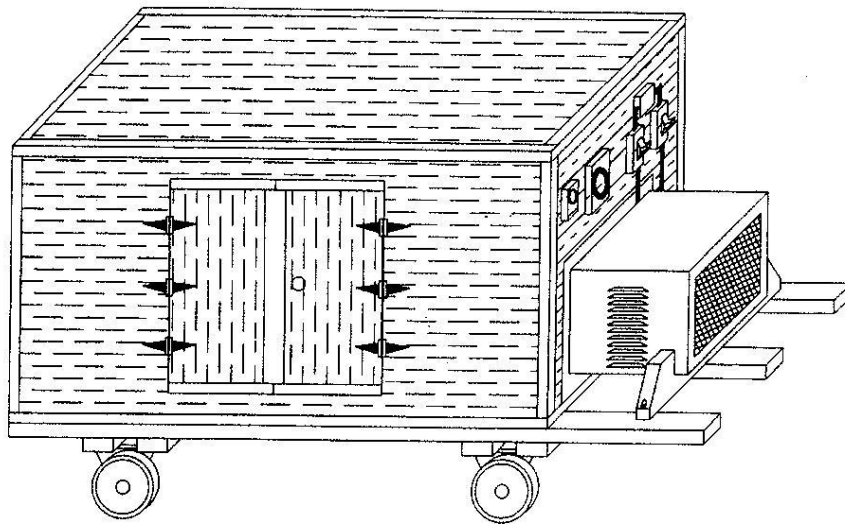

The original Portacooler was built by a cooperating team at USDA, Beltsville, Maryland; to cool highly perishable berries and other air cooled produce. Approximate cost is \$US 1200, but the cost can be considerably lower if it is built with a used air conditioning unit. Complete plans are available on the internet on the ATTRA website (<http://www.attra.ncat.org>).

Source: Ross, D.S. 2002 *E-mail: dr27@umail.umd.edu*

The North Carolina State University **Pack n Cool** is the newest version of this portable cooling technology. Pack n Cool is constructed using a ready-made solid body trailer and is equipped with a CoolBot™ unit to help decrease the temperatures that can be achieved. Visit the link below for more information.

<http://ncsu.edu/enterprises/ncfreshproducesafety/refrigeration-units/pack-n-cool/>

Another example of a home built trailer with Coolbot™ can be seen on the website:

<http://www.evergoodfarm.com/trailerbuild.html>

## Refrigerated Trailers

For optimum transport temperature management, refrigerated trailers need insulation, a high-capacity refrigeration unit and fan, and an air delivery duct. The checklist below includes these and other desired features in a top-air delivery trailer.

- Refrigerated Vehicles-- Pre-loading Checklist
- Refrigeration unit operating properly?
- Thermostat calibrated?
- Refrigeration air chutes and ducts properly installed and in good repair?
- Door seals in good condition?
- Doors seal tightly when closed?
- Walls free of cracks and holes?
- Front bulkhead installed?
- Floor drains open?
- Inside of vehicle clean and odor-free?
- Floor grooves free of debris?
- Inside height, width, length adequate for load?
- Load braces and other devices available to secure load?
- Is the vehicle trailer pre-cooled (or pre-warmed)?

Source: Ashby, B. H. et al. 1987. Protecting Perishable Foods During Transport by Truck. Washington, D.C.: USDA, Office of Transportation, Agricultural Handbook No. 669.

The condition of the inside of a refrigerated trailer affects its ability to maintain desired temperatures during transport. Handlers should inspect the trailer before loading and check these features:

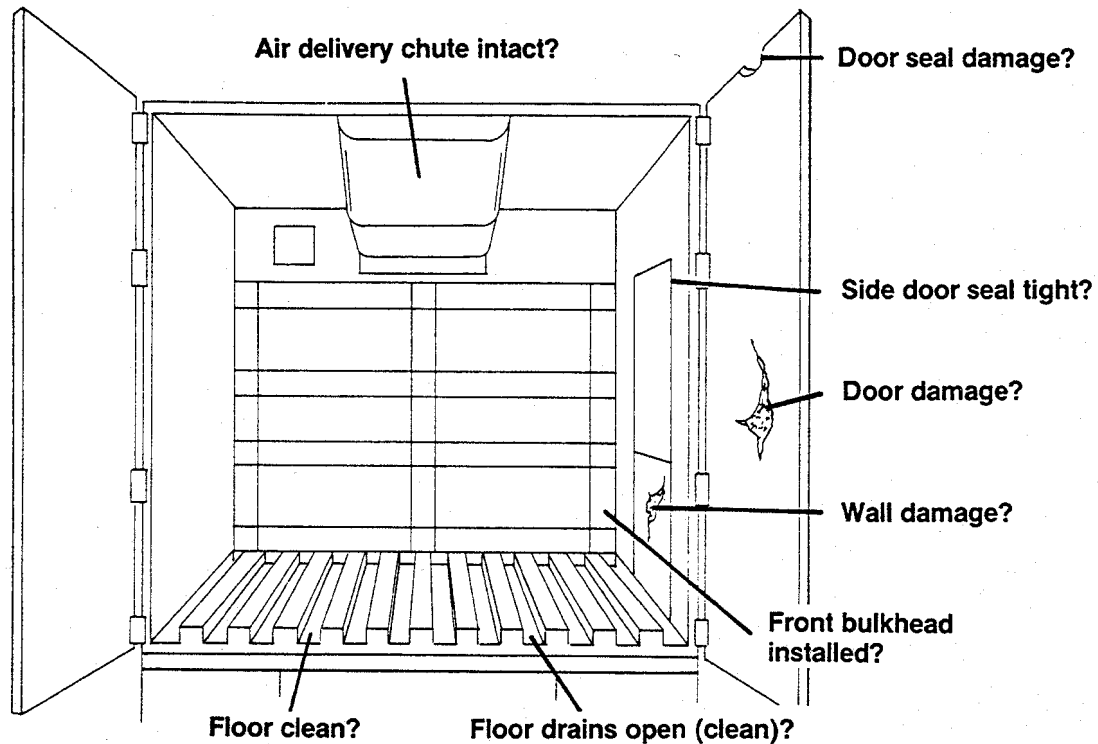

- |   |  |
|---|--|
| <b>Inside width adequate for load?</b>  | <b>Load bars used to secure load?</b>              |
| <b>Inside height adequate for load?</b> | <b>Trailer precooled before loading?</b>           |
| <b>Door height adequate for load?</b>   | <b>Refrigeration unit operates satisfactorily?</b> |

Source: Kasmire, R.F. and Hinsch, R.T. 1987. Maintaining Optimum Transit Temperatures in Refrigerated Truck Shipments of Perishables. University of California Perishables Handling Transportation Supplement No. 2.

## Stacking Patterns/Hand-stacked

Bushels (very sturdy, uniformly made, stackable baskets) of produce can be loaded into a refrigerated trailer using a pattern of alternately inverted layers that leave plenty of space between rows for air circulation.

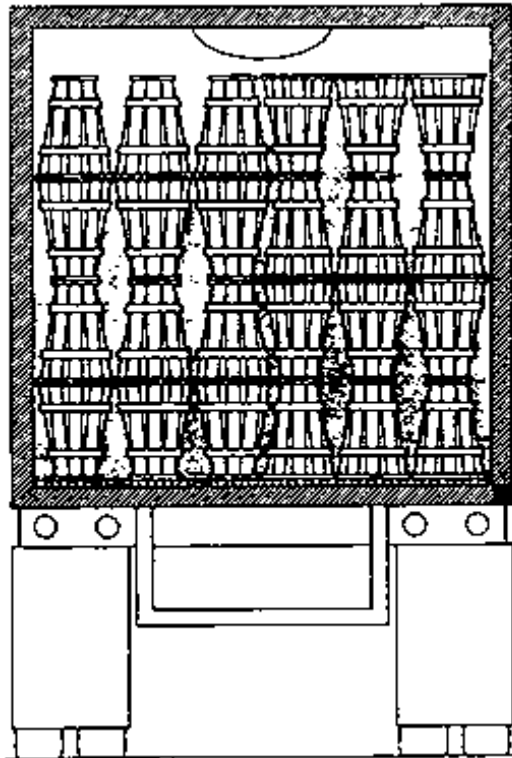

Source: Ashby, B. H. et al. 1987. Protecting Perishable Foods During Transport by Truck. Washington, D.C.: USDA, Office of Transportation, Agricultural Handbook No. 669.

Produce transported in cartons should also be stacked to allow adequate air circulation throughout the load. The diagram below illustrates cross-wise offset loading of partial telescopic containers. On the floor of the truck, pallets or other supports should be used to keep the cartons out of direct contact with the floor.

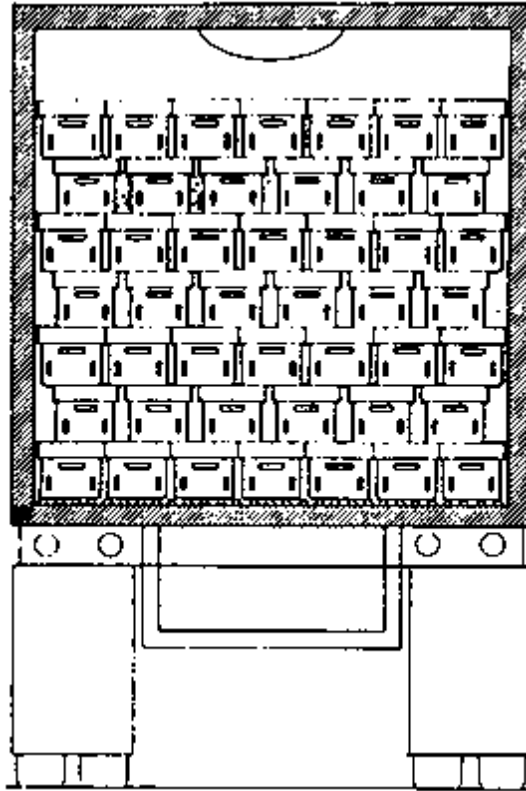

Source: Ashby, B. H. et al. 1987. Protecting Perishable Foods During Transport by Truck. Washington, D.C.: USDA, Office of Transportation, Agricultural Handbook No. 669.

When cartons of various sizes must be loaded together, the larger, heavier containers should be placed on the bottom of the load. Parallel channels should be left for air to move through the length of the load.

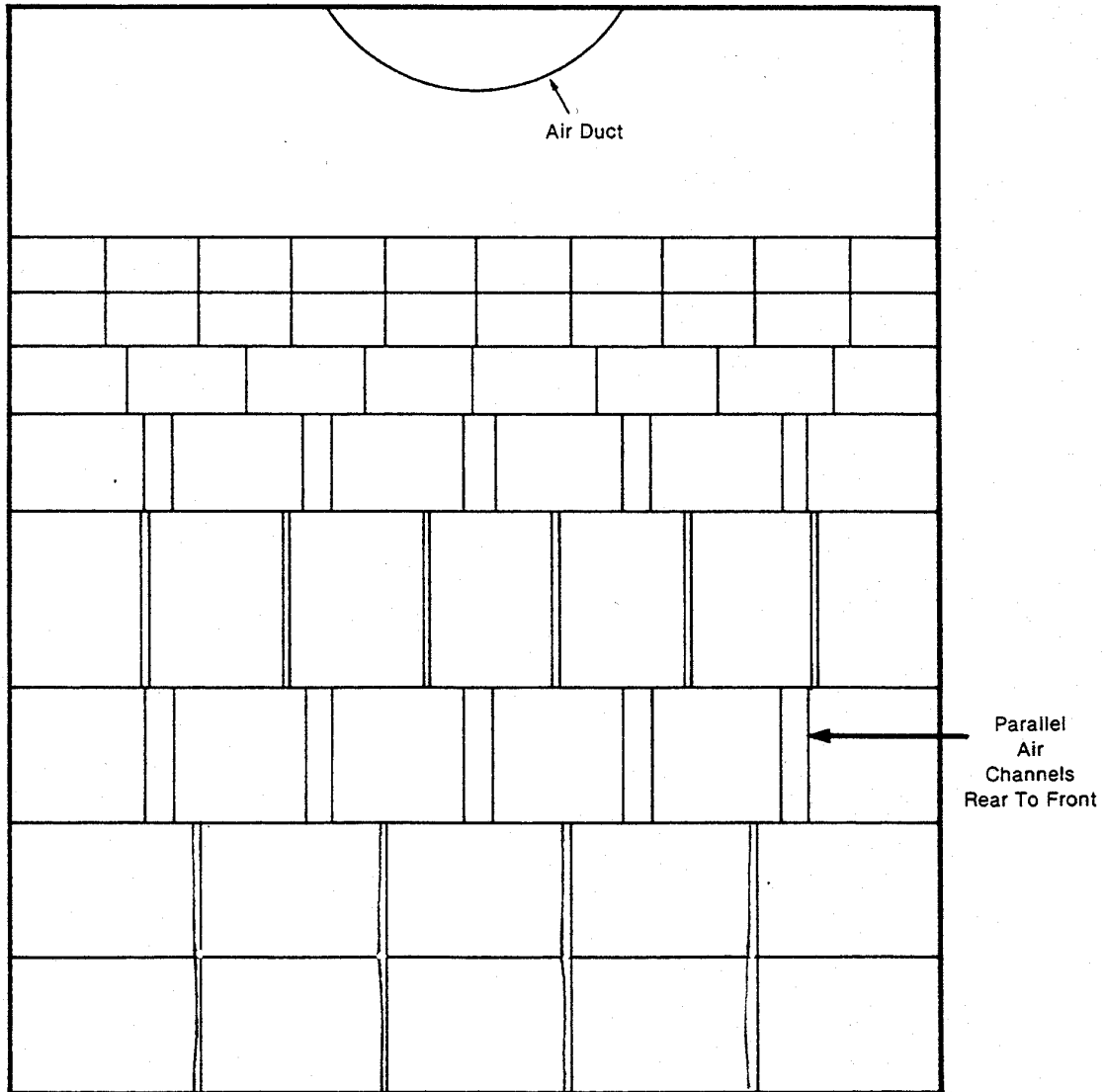

Source: Nicholas, C.J. 1985. Export Handbook for U.S. Agricultural Products. USDA, Office of Transportation, Agricultural Handbook No. 593

Often the large containers used for cut flower packaging must be hand-stacked when loaded into a transport vehicle. The best loading pattern for cut flowers is known as the pigeon hole pattern, in which boxes are stacked in alternating solid and open layers, and channels are left down both side walls. This pattern provides channels for air circulation lengthwise through the load, and allows every box to be in direct contact with refrigerated air.

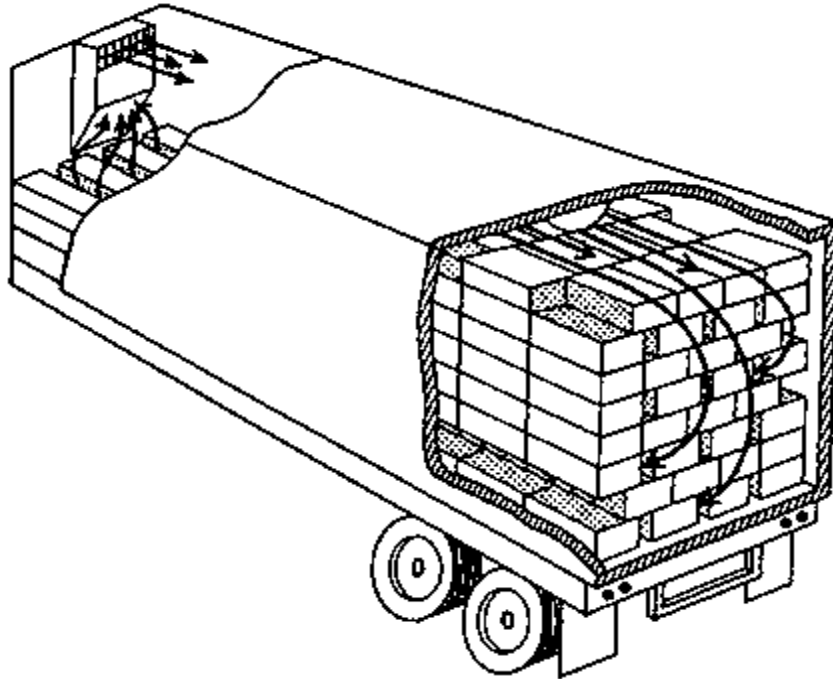

Source: Rij, R et al. 1979. Handling, Precooling and Temperature Management of Cut Flower Crops for Truck Transportation. USDA Science and Education Administration. AAT-W-5, UC Leaflet 21058.

## Stacking Patterns/Pallet and Slip Sheet loads

Containers should be loaded so that they are away from the side walls and the floor of the transport vehicle in order to minimize the conduction of heat from the outside environment. In the diagrams below, the numbers of cartons refer to how many cartons would be in contact with the walls and floor of the truck when fully loaded.

Only the load on the bottom right is fully protected from heat transfer. The use of pallets keeps the cartons off the floor, while center-loading leaves an insulating air space between the pallet loads and the outside walls.

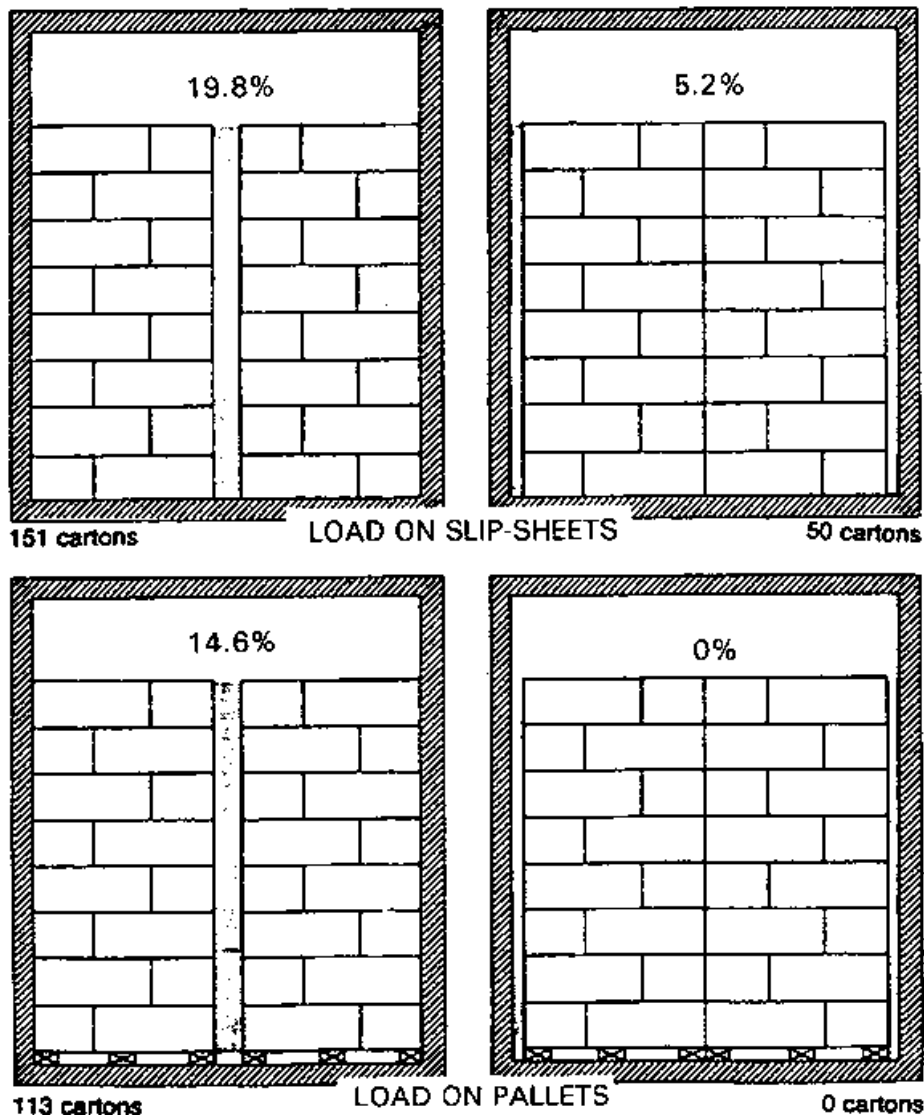

Source: Ashby, B. H. et al. 1987. Protecting Perishable Foods During Transport by Truck. Washington, D.C.: USDA, Office of Transportation, Agricultural Handbook No. 669.



## Stacking Strength

When stacking containers, be sure to align them properly. Whenever possible, stack them so that corner matches corner on both the cartons and the pallet. Most of the strength of corrugated fiberboard containers is in their corners, so an over-hang of only 1 inch (2.5 cm) will decrease stacking strength by 15 to 34%.

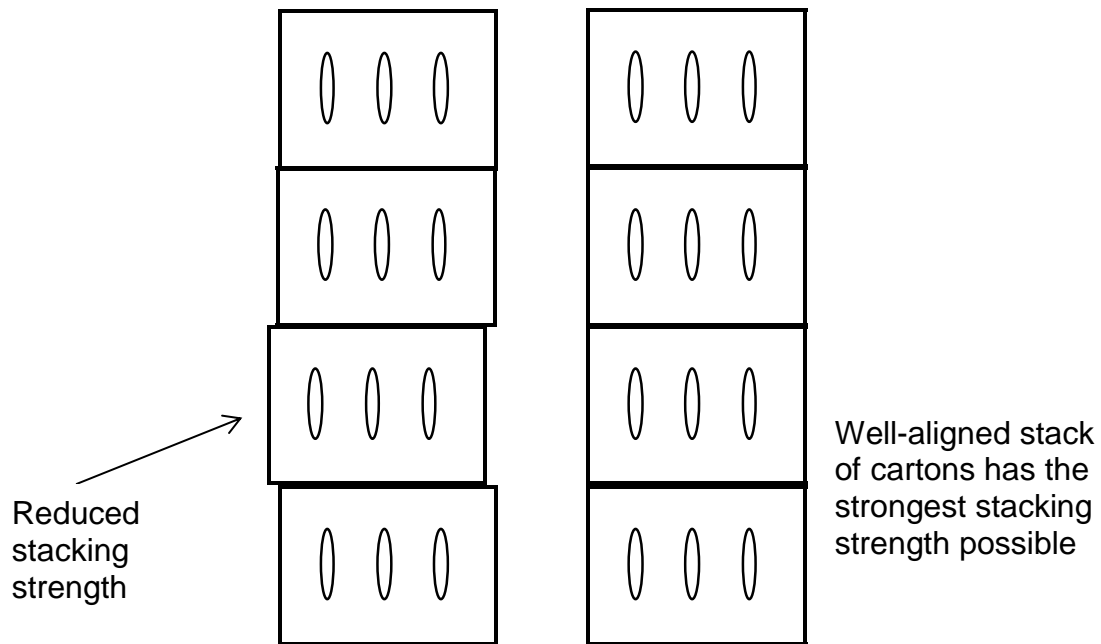

## Bracing the Load

There should always be a void between the last stack of produce and the back of the transport vehicle. The load should be braced to prevent shifting against the rear door during transit. If the load shifts, it can block air circulation, and fallen cartons can present great danger to workers who open the door at a destination market. A simple wooden brace can be constructed and installed to prevent damage during transport.

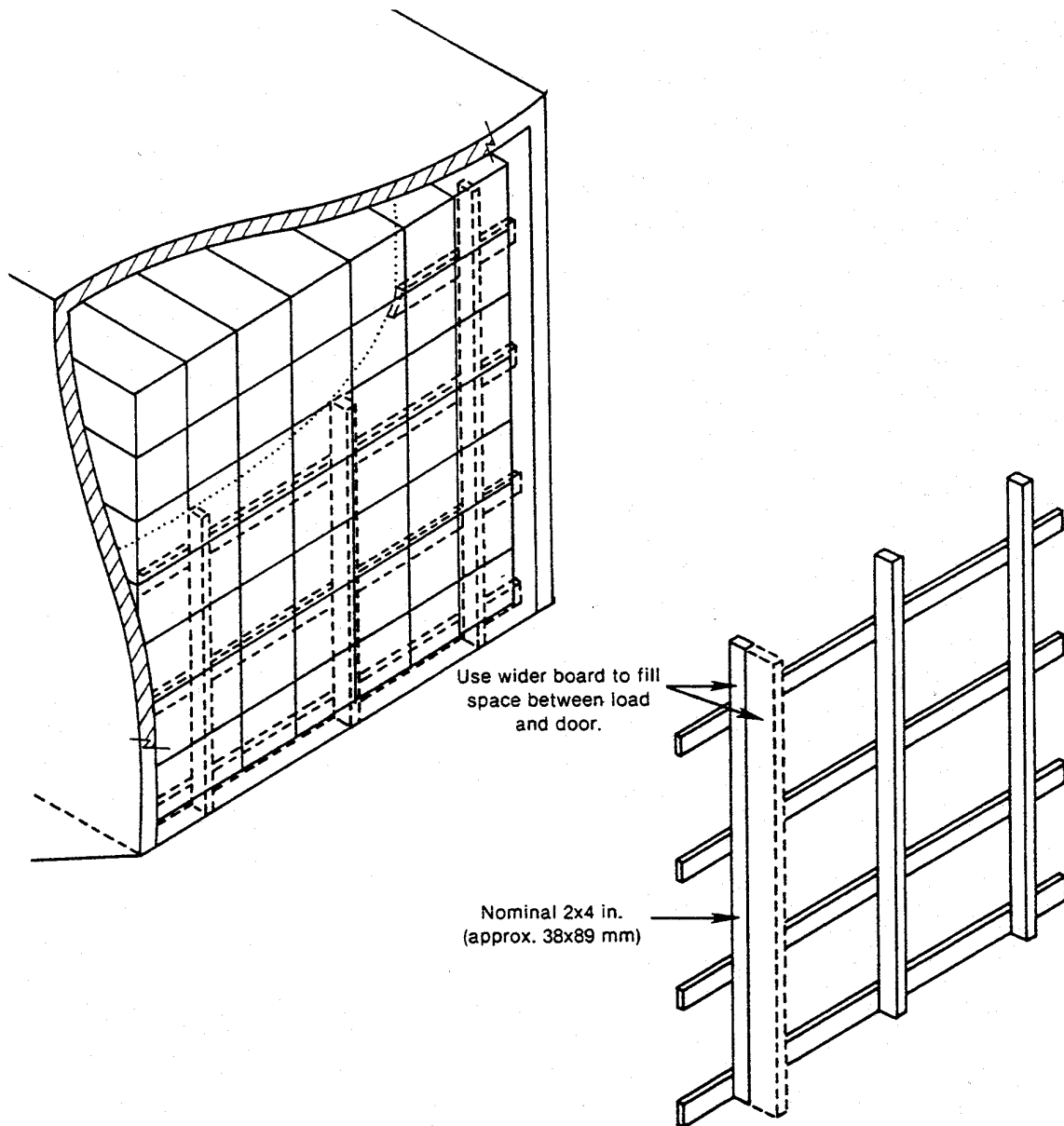

Source: Nicholas, C.J. 1985. Export Handbook for U.S. Agricultural Products. USDA, Office of Transportation, Agricultural Handbook No. 593

Bracing the load can be accomplished using wooden braces, load rails, air pillows or Styrofoam blocks. The key is to immobilize stacked produce to reduce damage during transport.

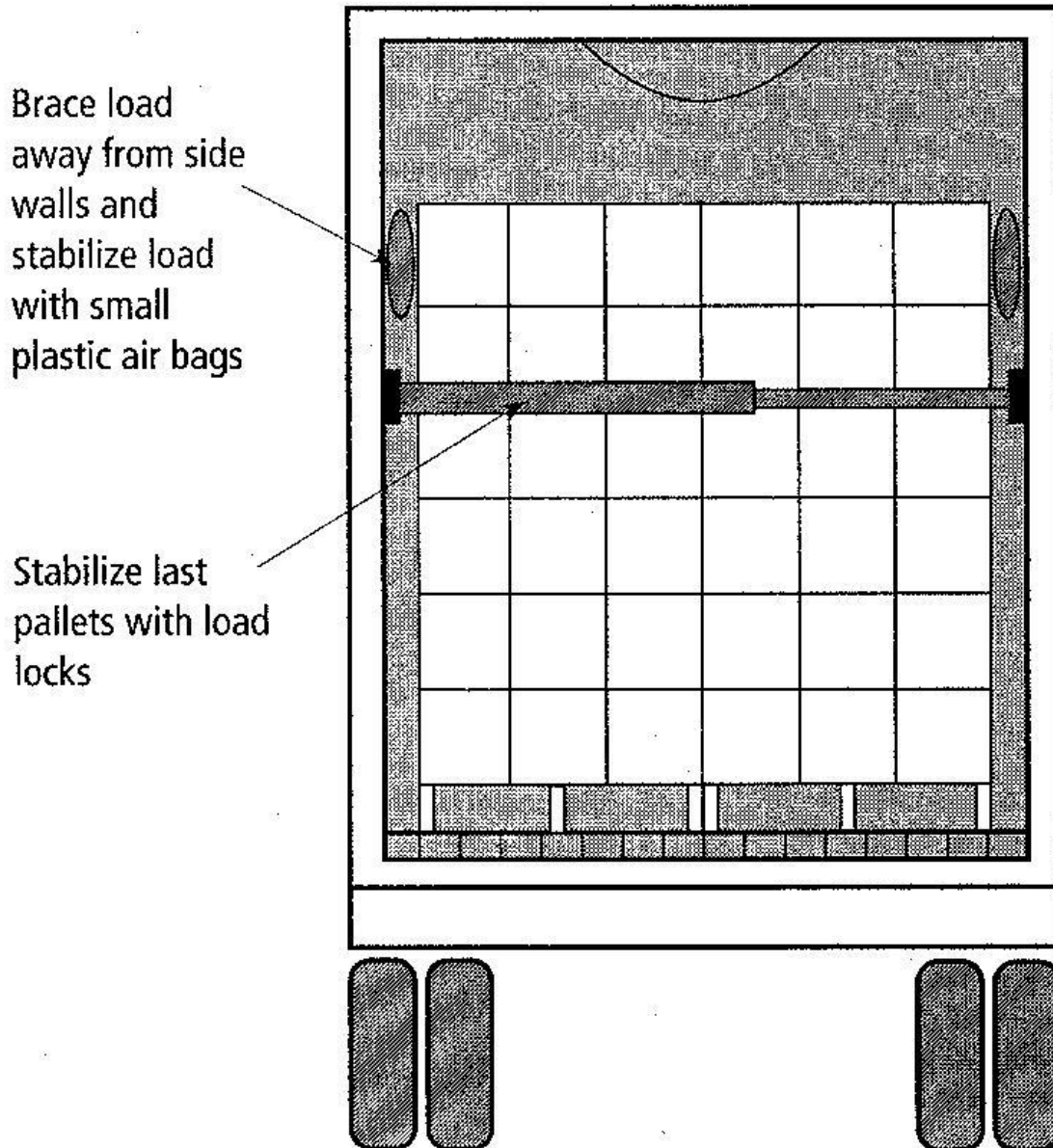

Source: Thompson, J.F. 2002. Transportation. In: Kader, A.A. Postharvest Technology of Horticultural Crops (3rd Edition). UC Publication 3311. University of California, Division of Agriculture and Natural Resources. p.259-269.

## Air Transport

To prevent shifting of the load in a cargo container for air transport, a piece of solid foam or folded fiber-board should be placed along the curved or triangular portion of the floor of the container. Cartons stacked on top will be much better supported and be held upright.

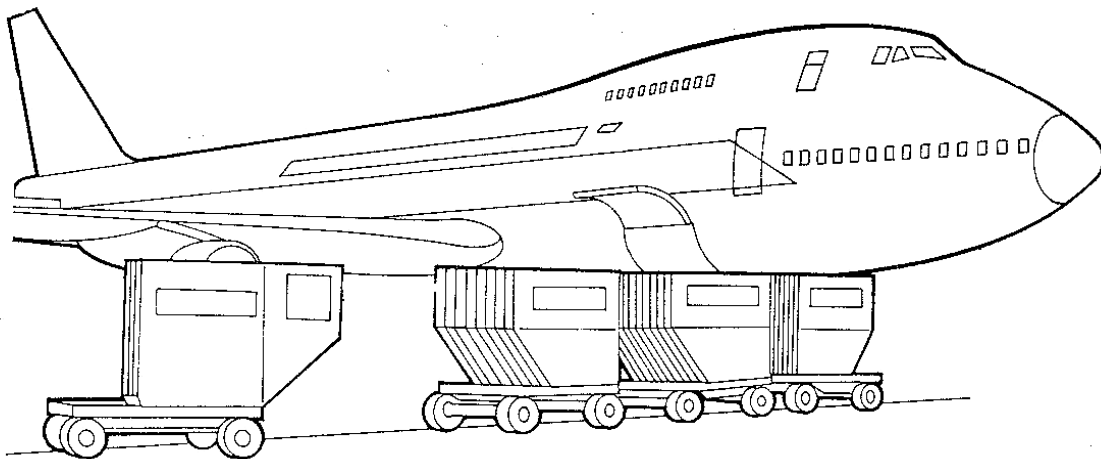
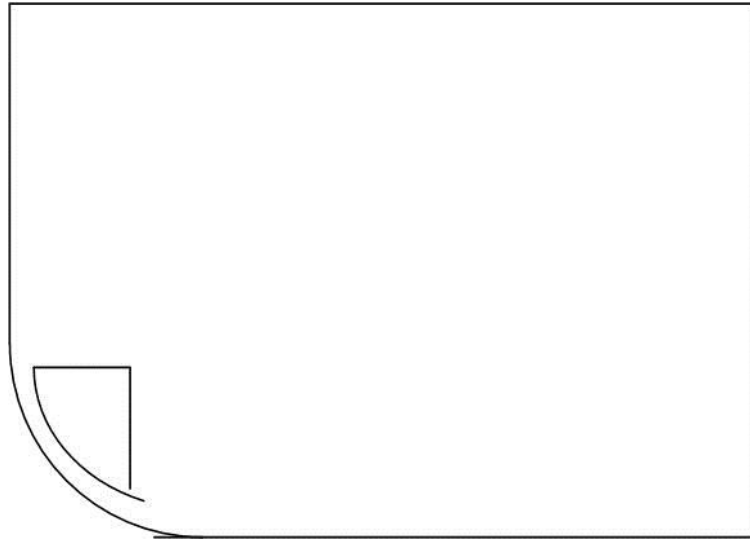

Source: McGregor, B. 1987. Tropical Products Handbook. USDA Office of Transportation Agricultural Handbook Number 668.

## **Chapter 9: Handling at Destination**

---

When handling produce at its destination, again it is important to avoid rough handling, minimize the number of handling steps, and maintain the lowest feasible and safe temperature for the commodity. If produce is to be stored before sale, then wholesale and retail markets need clean, well-insulated storage rooms. Since a variety of commodities is usually being handled simultaneously at this point, it is important to remember not to mix those with different temperature requirements or store ethylene-sensitive commodities near ethylene-generating commodities. Stacking of non-uniform containers should be done with care to prevent collapse of weaker packages. Also, weaker and lighter packages should be stacked higher rather than at the bottom of the stack.

Before produce is sold to the consumer, the handler may wish to sort for quality, or at least discard any damaged or decayed produce in order to give the product more market appeal. If ripeness or maturity is non-uniform, sorting at destination can provide the seller with a higher price for the better quality produce.

If the produce handled is a climacteric fruit crop that was harvested before it was ripe (bananas, tomatoes, avocados, mangoes), the handler at destination may want to ripen the produce before it is sold to the public. Sometimes commodities such as bananas are left at ambient temperatures and allowed to ripen naturally. Covering the bananas with a plastic sheet will help ripening be more uniform throughout the lot (PHTRC, 1984). Placing a simple air vent (a pipe or a tube of some sort) into the center of the pile of ripening fruit can help reduce overheating during ripening and increase subsequent shelf life. The introduction of ethylene gas or ethylene-releasing compounds into a special storage environment (known as a ripening room or cabinet, depending upon size) is a more effective way to ensure uniform ripening.

Temperatures for the display tables or refrigerated supermarket displays should be suited to the commodity on sale. For example, while peppers and tomatoes look pleasing when displayed with lettuce, the peppers and tomatoes are chilling-sensitive, while lettuce is not. Displaying them together (at the same storage temperature) will damage one or the other.

Misting commodities that can tolerate surface water (lettuce, broccoli, green onions) with cool clean water can help maintain a high relative humidity around the product. The water used for misting must be clean (potable) and never recycled.

Outdoor marketplaces suffer from a lack of temperature control and high air circulation, which can lead to desiccation of crops, which is due to rapid water loss and will be seen as shriveling and wilting. These marketplaces can often benefit by the increased use of shading and protection from prevailing winds. In the USA one source for shade cloth (woven or knitted) is <http://factorydirectlandscape.com>

Finally, the handler at destination can help reduce losses in the future by maintaining good records of the sources of losses suffered at the wholesale or retail level (Kasmire & Ahrens in Kader, 1992). Identifying whether losses were due to mechanical damage, decay/disease, immaturity or over-ripeness allows the handler to provide better quality feedback to produce suppliers.

### Best practices for destination handling

| DO  | DO NOT  |
|---|---|
| Handle gently and carefully when unloading and stacking.  | Put incompatible types of produce in the same storage room (check for temperature requirements) |
| Minimize the number of handling steps.  | Display produce in direct sunlight  |
| Re-sort to removed decayed or damaged produce.  | Display chilling-sensitive produce in a cold refrigerated case                                  |
| Ripen produce such as bananas and avocados to improve quality before sale.  |   |
| Use a simple air vent (a pipe or a tube of some sort) in the center of the pile of ripening fruit to help reduce overheating during ripening. |   |
| Mist commodities that can tolerate surface water (lettuce, broccoli, green onions) with cool clean water.                                     |   |
| Provide shade and wind protection for any produce being marketed outdoors.  |   |
| Keep good records regarding the causes of any losses.   |   |

## Unloading

A loading dock can ease the work associated with handling horticultural produce at destination. Containers can be transferred in and out of the truck more rapidly and with less bending and lifting.

For large trucks, a loading dock 117 to 122 cm high (46 to 48 inches) functions well, while for small trucks or pickups a height of 66 to 81 cm (26 to 32 inches) is recommended.

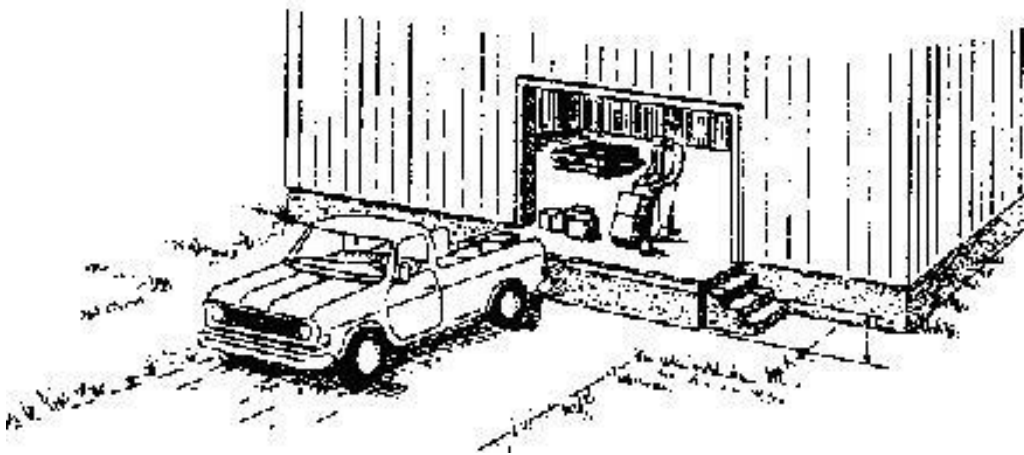

Source: Selders, A.W. et al. 1992. Facilities for Roadside Markets. Northeast Regional Agricultural Engineering Service/ Cornell University Cooperative Extension.

A simple device for easing the work of unloading transport vehicles can be constructed using two pulleys and a strong rope. One pulley can be mounted inside the truck at the front of the bed, the second outside on a portable post or on a stationary object like the side of a building. Containers can be hung directly by the handles or placed into a sling.

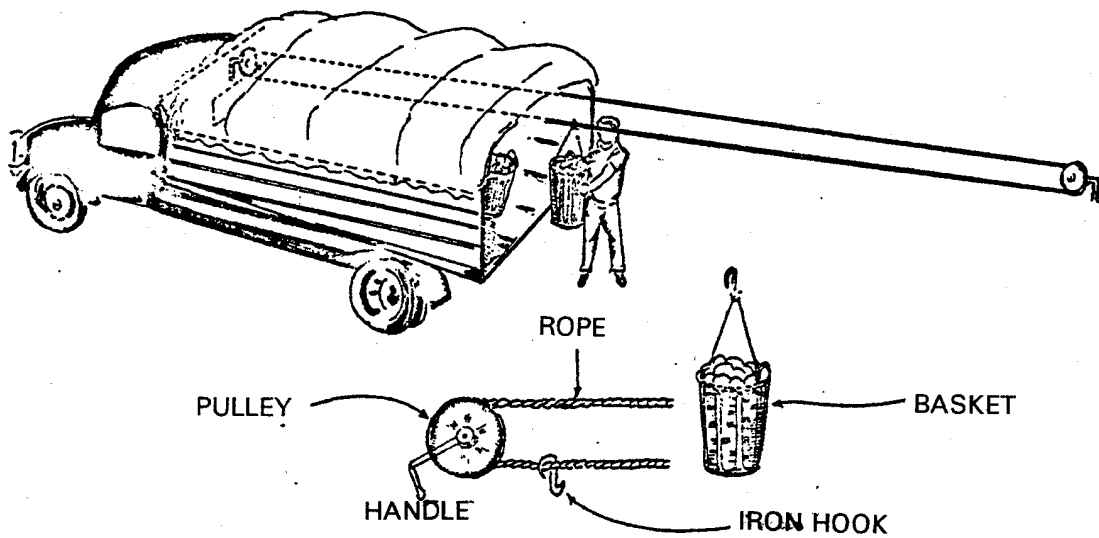

Source: Pantastico, Er. B. 1980. FAO/UNEP Expert Consultation on Reduction of Food Losses in Perishable Products of Plant Origin. Working Document 2: Fruits and Vegetables. (6-9 May, Rome: FAO)



Using a ramp is a simple and safe method for unloading produce. The ramp should be wide enough to prevent accidents and strong enough to carry the full weight of the handler plus the package she/he is carrying. Providing hand-trucks or small carts can also ease the work associated with unloading.

If there is no loading dock or ramp, a simple set of stairs can be constructed to ease the work of loading and unloading produce. The stairs illustrated here can be folded and pushed back under the back of the truck when the vehicle is in motion. The steps can be made of wood or steel matting and steel bars can be used for supports.

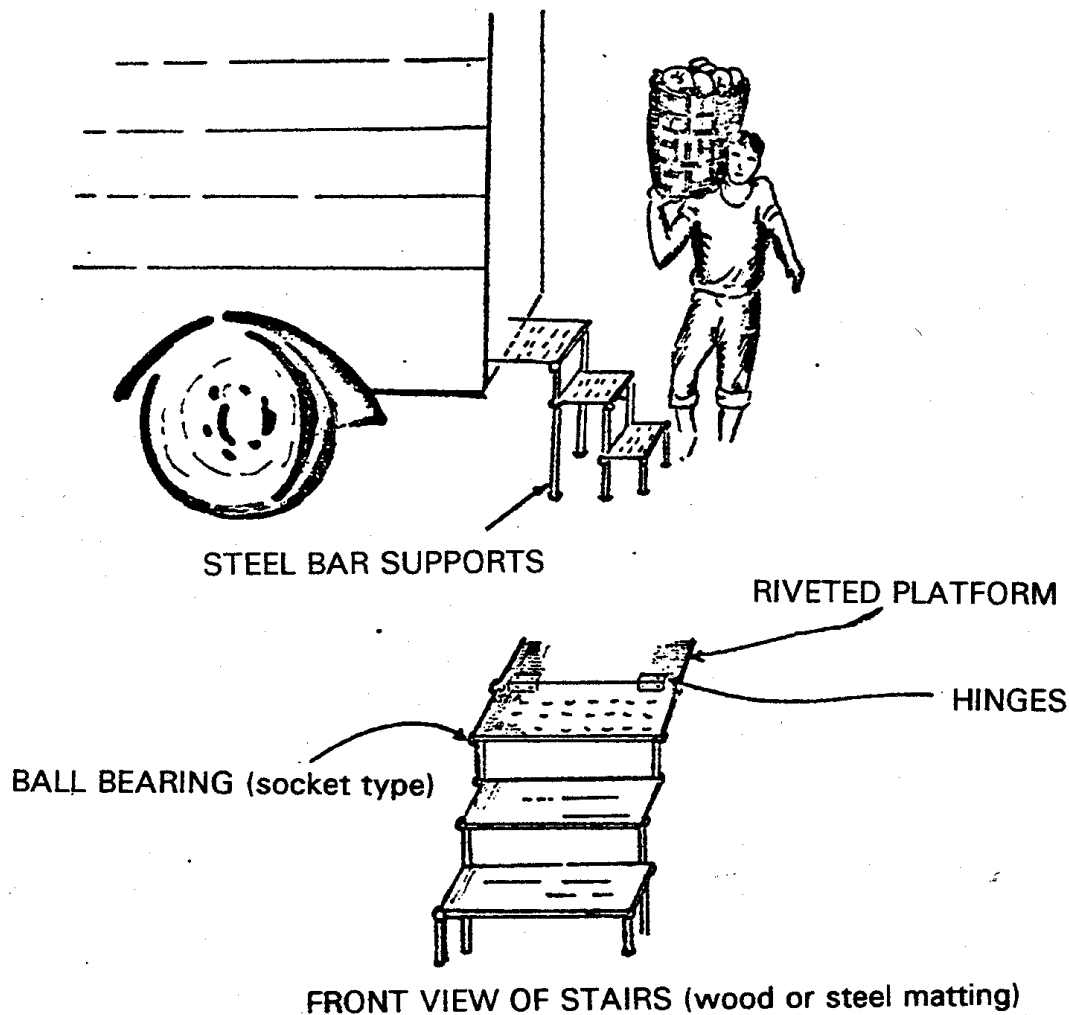

Source: Pantastico, Er. B. 1980. FAO/UNEP Expert Consultation on Reduction of Food Losses in Perishable Products of Plant Origin. Working Document 2: Fruits and Vegetables. (6-9 May, Rome: FAO)

## Temporary Storage Temperatures

When produce is held at destination for a short time before marketing, the handler can help maintain quality and reduce losses by storing commodities at their most suitable temperature. However, if the storage period is seven days or less, relative humidity is maintained between 85 and 95%, and the ethylene level is kept below 1 ppm by ventilating or using a scrubber or absorber. Most commodities can be handled and stored according to the following three temperature-based groups.

| 0-2 °C (32-36 °F)            |                   | 7-10 °C (45-50 °F) |                            | 13-18 °C (55-65 °F)       |
|------------------------------|-------------------|--------------------|----------------------------|---------------------------|
| <b>Vegetables and Melons</b> |                   |                    |                            |                           |
| Anise                        | Collard*          | Parsnip            | Basil                      | Casaba melon              |
| Artichoke                    | Cut vegetables    | Radicchio          | Beans; snap, etc.          | Cassava                   |
| Arugula*                     | Daikon*           | Radish             | Cactus leaves              | Crenshaw melon            |
| Asparagus*                   | Endive*           | Rutabaga           | Cucumber*                  | Dry onions                |
| Bean sprouts                 | Escarole*         | Rhubarb            | Eggplant*                  | Ginger                    |
| Beet                         | Garlic            | Salsify            | Juan Canary                | Honeydew melon            |
| Belgian endive*              | Green onion*      | Shallot            | Melon                      | Jicama                    |
| Bok choy                     | Herbs (not basil) | Spinach*           | Kiwano                     | Potato                    |
| Broccoli*                    | Horseradish       | Snow pea*          | Okra*                      | Persian melon             |
| Broccoflower*                | Jerusalem         | Sweet corn         | Pepper; bell               | Pumpkin                   |
| Brussel sprouts*             | Artichoke         | Sweet pea*         | Chili                      | Squash; winter, hard rind |
| Cabbage*                     | Kale              | Swiss chard        | Squash; summer, soft rind* | Sweet potato*             |
| Cantaloupe                   | Kohlrabi          | Turnip             | Tomatillo                  | Taro                      |
| Carrot*                      | Leek*             | Turnip greens*     | Watermelon*                | Tomato; ripe              |
| Cauliflower*                 | Lettuce*          | Water chestnut     |                            | Mature green              |
| Celeriac                     | Mint              | Watercress         |                            | Yam*                      |
| Celery*                      | Mushroom          |                    |                            |                           |
| Chard*                       | Mustard greens*   |                    |                            |                           |
| Chicory*                     | Parsley*          |                    |                            |                           |

| 0-2 °C (32-36 °F) |                | 7-10 °C (45-50 °F) |               | 13-18 °C (55-65 °F) |            |
|-------------------|----------------|--------------------|---------------|---------------------|------------|
| <b>Fruits</b>     |                |                    |               |                     |            |
| Apple             | Fig            | Avocado, unripe    | Mandarin      | Atemoya             | Mango      |
| Quince            | Gooseberry     | Cactus pear, tuna  | Olive         | Banana              | Mangosteen |
| Apricot           | Grape          |                    | Orange        | Breadfruit          | Papaya     |
| Raspberry         | Kiwifruit*     | Carambola          | Passion Fruit | Cherimoya           | Plantain   |
| Avocado, ripe     | Nectarine      | Chayote            | Pepino        | Coconut             | Pummelo    |
| Strawberry        | Peach          | Cranberry          | Pineapple     | Grapefruit*         | Rambutan   |
| Blackberry        | Pear; European | Guava              | Tamarillo     | Lime*               | Soursop    |
| Cherry            | Persimmon*     | Kumquat            | Tangelo       |                     |            |
| Currant           | Plum           | Longan             | Tangerine     |                     |            |
| Cut Fruits        | Prune          | Lychee             |               |                     |            |
| Date              |                |                    |               |                     |            |

\* Products marked with an asterisk are sensitive to ethylene damage.

Source: Thompson, J.F., Kader, A.A. and Sylva, K. 1995. Compatibility Chart for Fruits and Vegetables in Short-term transport or Storage. University of California DANR Publication 21560 (poster).

## Sorting/Repacking

Some produce may require washing, trimming, bunching or sorting at the wholesale or retail market level. The layout of the work station used for handling produce at destination should be organized to minimize non-productive movement. In the illustration below, a dump table is located next to a sink for washing produce, and the drain board is positioned directly next to the sink. Once produce has dried, cartons can be packed and placed onto a cart located right next to the repacking table. With this layout, a single operator could easily perform all the handling steps or several handlers could work side by side.

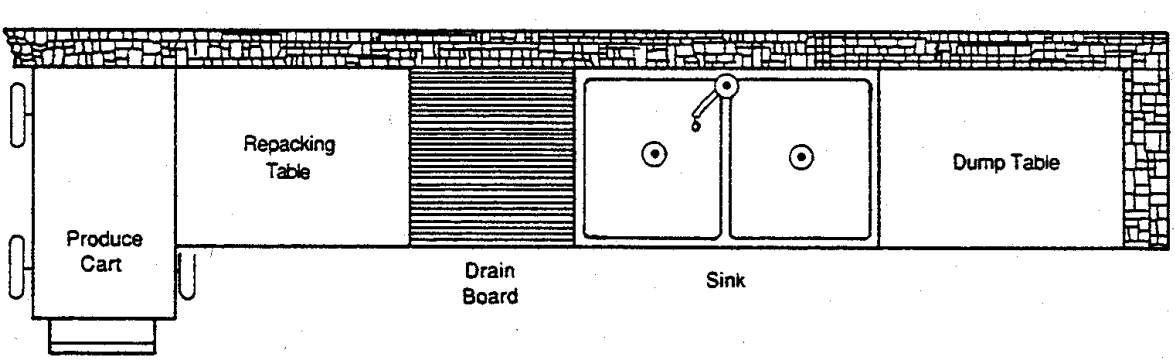

Source: Selders, A.W. et al. 1992. Facilities for Roadside Markets. Northeast Regional Agricultural Engineering Service/ Cornell University Cooperative Extension.

Some produce may have to be repacked by the wholesaler or retailer due to changes in quality or uneven ripening. The tomato sorting table illustrated below has work stations for up to five who select either ripe, pinks or breakers and allow the green tomatoes to run off to the end of the line. Rejects (culls) are placed in pails under the table.

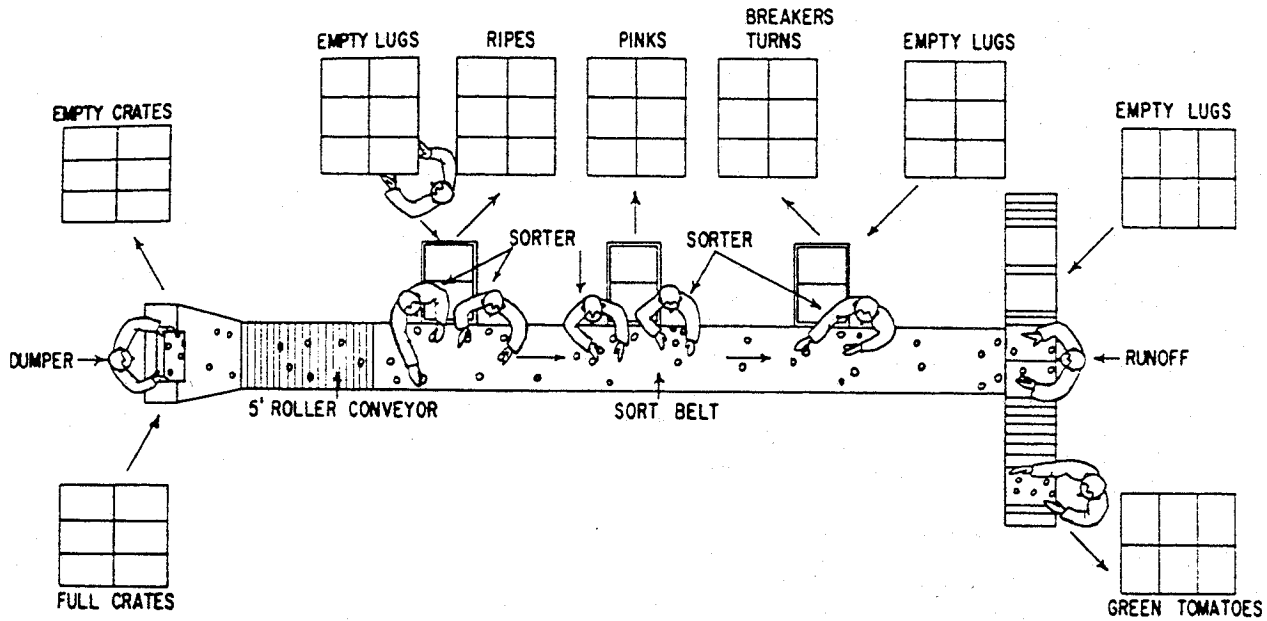

Source: USDA. No date. Tomato repacking methods and equipment. USDA Marketing Service, Transportation and Facilities Research Division, Marketing Research Report No. 597

## Ripening

Ripening is the process by which fruits attain their desirable flavor, color and textural properties. **Climacteric fruits can ripen off the plant** once they have reached physiological maturity.

**Climacteric** fruits include apples, avocados, bananas, blueberries, breadfruits, cherimoyas, durians, feijoas, figs, guavas, kiwifruits, mangos, muskmelons, papayas, passion fruits, pears, persimmons, plantains, quinces, sapodillas, sapotes, soursops, stone fruits (apricots, nectarines, peaches, plums) and tomatoes. Some of these fruits, if harvested "mature-green", can be ripened after harvest and short-term storage.

Pears and bananas are unusual in that they develop the best flavor and texture characteristics when harvested mature-green and ripened off the tree. On the other hand, avocados do not ripen on the tree.

Some climacteric fruits produce large quantities of ethylene during ripening. These include apples, apricots, avocados, cantaloupe, kiwifruit, nectarines, peaches, pears, plums and passion fruit. A small dose of ethylene gas will stimulate other climacteric fruits to begin the ripening process. A few climacteric fruits, such as muskmelons, will not increase in sugar content during ripening, but will soften.

**Non-climacteric** fruits must ripen on the plant until fully ripe, since after being harvested no further ripening will occur. Flavor and texture will be of low quality if fruits are picked before fully ripe.

Some **non-climacteric** fruits include berries, cherries, citrus fruits (lemons, limes, oranges, grapefruits, mandarins, tangerines), cucumbers, dates, eggplants, grapes, lychee, okras, peas, peppers, pineapples, pomegranates, strawberries, summer squashes, tamarillos and watermelons.

Non-climacteric fruits will not respond to attempts to ripen them with ethylene gas. A partially red strawberry, for example, will not develop any more color or sweetness after being picked, and will deteriorate faster if exposed to ethylene. Watermelons develop most of their sweetness during the week before they reach full maturity, making early harvest very undesirable.

Sometimes ripening commodities before sale at the wholesale or retail level will improve their value. Ripening rooms are often used for tomatoes, citrus fruits and bananas. The use of diluted ethylene gas mixtures is safer than using pure ethylene, which is explosive and flammable at concentrations of 3% or higher.

For tomatoes, technical grade ethylene gas is introduced into the room at a concentration of about 100 ppm for about 48 hours. Approximately 0.25 cubic feet/hr (0.025 m<sup>3</sup>/hr for each 100 m<sup>3</sup> of ripening volume) of ethylene gas is required for each 1000 cubic feet of ripening room volume. A small fan can be used to ensure a uniform continuous flow of ethylene into and through the room. Forced-air ripening is increasingly being used to provide more uniform temperatures and ethylene concentrations throughout the ripening room.

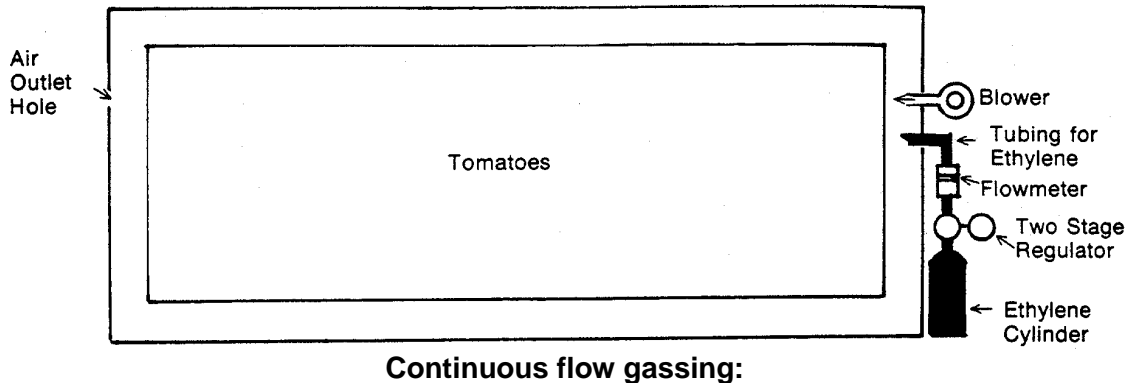

Source: Kasmire, R.F. 1981. Continuous flow ethylene gassing of tomatoes. California Tomatorama. Fresh Market Tomato Advisory Board Information Bulletin No. 29.

For more information about ethylene generators, see the Internet sites of American Ripener Co., Inc. at [www.ripening.com](http://www.ripening.com) or Catalytic Generators, Inc. (International Ripening Company) at [www.Qasupplies.com](http://www.Qasupplies.com).

Ripening can also be initiated by using ethylene generated by passing ethanol over a bed of activated alumina. This method is safer than using pure ethylene gas.

Ethylene-releasing compounds such as ethephon {(C<sub>2</sub>H<sub>6</sub>ClO<sub>3</sub>P - 2-chloroethyl) phosphoric acid} are sometimes used to ripen tomatoes destined for processing. When using ethephon as a spray, the amount of ethylene released will increase as pH and/or relative humidity increase.

Source: Kays, S.J. and Beaudry, R.M. 1987. Techniques for inducing ethylene effects. *Acta Horticulturae* 201:77-115.

Ethephon is also approved in many countries for a variety of ripening and de-greening uses as shown in the following table:

**Approved uses for Ethephon (2-chloroethane phosphonic acid) in US agriculture.**

| Use                           | Approved crops and States (if no State is indicated in parentheses, then the use is approved in all States) |
|-------------------------------|---|
| Postharvest fruit ripening    | Bananas, tomatoes (FL)  |
| Pre-harvest fruit ripening    | Peppers, tomatoes   |
| Fruit removal                 | Apples, carob, crabapples, olive  |
| Defoliation                   | Apples, buckhorn, cotton, roses   |
| Fruit loosening               | Apples, blackberries (WA, OR), cantaloupes, cherries (CA, AZ, TX), tangerines                               |
| Maturity or color development | Apples, cranberries (MA, NJ, WI), figs (CA), filberts (OR), grapes, peppers, pineapple, tomatoes.           |
| De-greening (preharvest)      | Tangerines  |
| De-greening (postharvest)     | Lemons  |
| Dehiscence                    | Walnuts   |
| Leaf curing                   | Tobacco   |
| Flower induction              | Pineapple and other bromeliads  |
| Sex expression                | Cucumber, squash  |
| Flower bud development        | Apple   |
| Plant height control          | Barley, daffodils, hyacinth, wheat  |
| Stimulate lateral branching   | Azaleas, geraniums  |

Source: Reid, M.S. 2002. Ethylene in Postharvest Technology pp.149-162. In: Kader, A.A. (ed). Postharvest Technology of Horticultural Crops\_ Univ. of California, Div. of Agriculture and Natural Resources, Publication 3311.



The following table shows typical produce storage and ripening temperatures for some of the commodities that can be ripened.

| Commodity            | Respiration<br>(mg CO <sub>2</sub> / kg-<br>hr) <sup>1</sup> | Ethylene<br>(ppm) | Ethylene<br>exposure<br>time (hours) | Ripening<br>temp. °F (°C) | Storage<br>temp. °F (°C) | Specific heat<br>Btu/lb-F |
|----------------------|--|-------------------|--------------------------------------|---------------------------|--------------------------|---------------------------|
| Avocado              | 62-157   | 10-100            | 12-48                                | 59-65<br>(15-18)          | 40-55<br>(4.4-13)        | 0.81                      |
| Banana               | 25-110   | 100-150           | 24                                   | 59-65<br>(15-18)          | 56-58<br>(13-14)         | 0.81                      |
| Honeydew<br>melon    | 20-27  | 100-150           | 18-24                                | 68-77<br>(20-25)          | 45-50<br>(7-10)          | 0.94                      |
| Kiwifruit            | 16-22  | 10-100            | 12-24                                | 32-68<br>(0-20)           | 32-33<br>(0-0.5)         | 0.86                      |
| Mango                | 40-200   | 100-150           | 12-24                                | 68-72<br>(20-22)          | 56-58<br>(13-14)         | 0.85                      |
| Orange<br>degreening | 22-34  | 1-10              | 24-72                                | 68-72<br>(20-22)          | 41-48<br>(5-9)           | 0.90                      |
| Stone fruit          | 12-81  | 10-100            | 12-72                                | 55-77<br>(13-25)          | 31-32<br>(-0.5-0)        | 0.90                      |
| Tomato               | 24-44  | 100-150           | 24-48                                | 68-77<br>(20-25)          | 50-55<br>(10-13)         | 0.95                      |

<sup>1</sup>Multiply by 220 to obtain heat to respiration (BTU/ton/24 hours)

Source: Thompson, J.F. 1994. Ripening facilities. Perishables Handling Newsletter, Nov. 1994. Special Issue No. 80: 5-8.

The following illustration is a de-greening room designed for use with citrus in pallet boxes. The ceiling of the room is relatively high, allowing boxes to be stacked at least four high. A false ceiling is added to provide for adequate air movement throughout the room. For more detailed information on room construction, temperature and relative humidity management and air circulation, refer to the article entitled "Ripening Facilities" (Thompson, 1994) in the reference section of the manual.

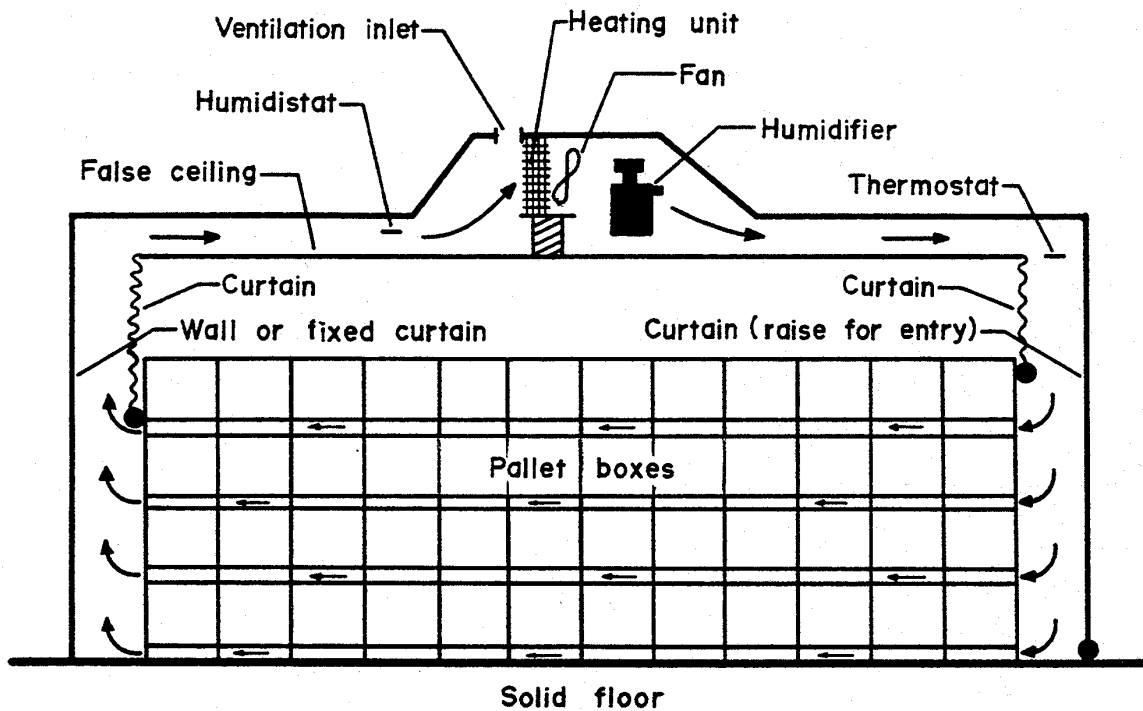

Source: USDA. No date. Modernizing Handling Systems for Florida Citrus from Picking to Packing Line. Agricultural Research Service, Marketing Research Report No. 914.

Several small ripening rooms may be more useful than a single large room for small scale handlers, since the amount of product handled at destination may vary from time to time. In this case, flow through systems can be designed to allow the use of one or more rooms at the same time.

Flowmeters can be located in one place for ease of monitoring, or can be strung out in a line. Locating all the flowmeters in one place requires the use of more tubing than if flowmeters are located in each ripening room. For more information and details on how to set up a flow through system for ripening fruit, see Sherman and Gull (1981).

#### Flowmeters in one location

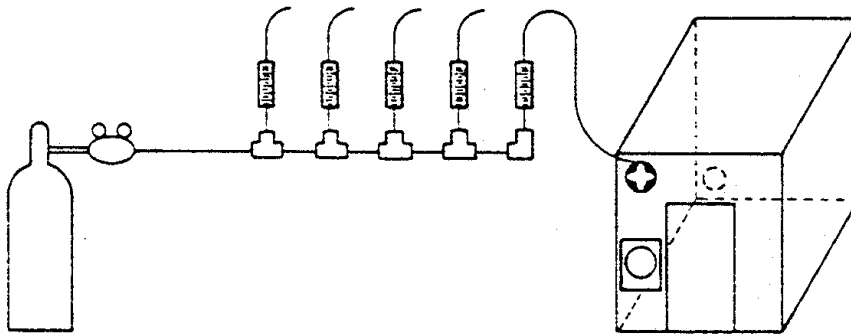

#### Flowmeters located in each ripening room

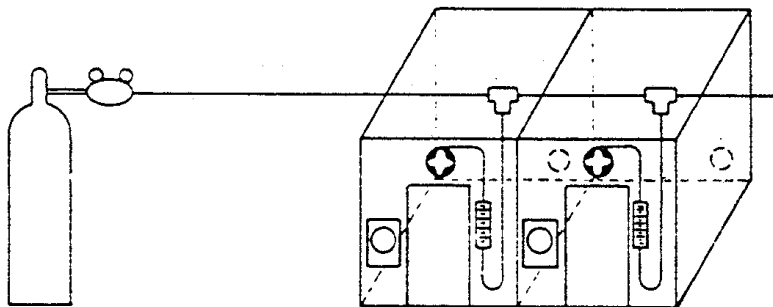

Source: Sherman, M. and Gull, D.D. 1981. A flow through system for introducing ethylene in tomato ripening rooms. University of Florida/IFAS, Vegetable Crops Fact Sheet 30.

Small-scale handlers can now lease portable ripening facilities from a variety of companies in the United States. The self-contained, portable system illustrated below features a 20 pallet capacity, high capacity air flow and is simple to operate. All that is needed is a loading dock and a supply of 220V electricity.

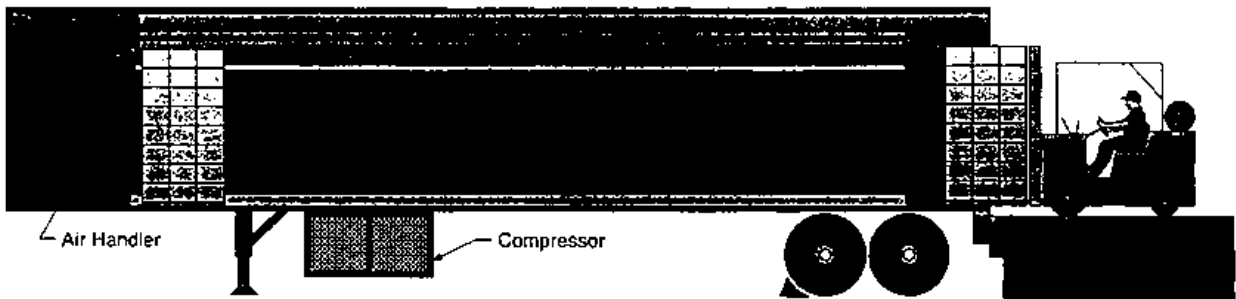

Source: Modular Ripening Company, Inc. 1994. Norfolk Virginia

Small-scale wholesalers and retailers can ripen fruits in bins or large cartons by placing a small quantity of ethylene-generating produce such as ripe bananas in with the produce to be ripened. Cover the bin or carton with a plastic sheet for 24 hours, then remove the plastic cover.

A simple way to ripen fruits at home in small amounts is to use a ripening bowl. Fruits that require ripening should be placed into the bowl with a ripe apple or ripe banana (or any other high ethylene-generating product). The bowl shown below is made of clear molded plastic and has ventilation holes around the top. Using this method, ripening will take from one to four days.

Home ripening is also possible using another, extremely low-tech practice-place fruits to be ripened into a paper bag with a ripe piece of fruit, close loosely and check in a few days.

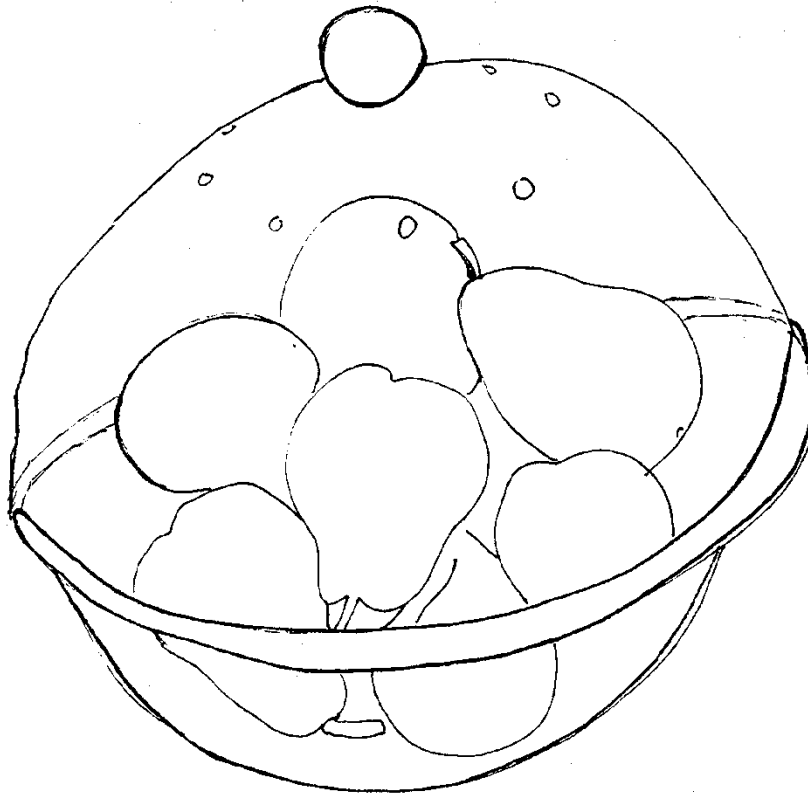

## Display

This wooden display table is designed to be used for commodities such as cruciferous crops or leafy green vegetables that tolerate cooling with ice. The table can be used in the horizontal position or as a tilted display. For more complete design specifications, contact the Cornell University Extension Service, 304 Riley-Robb Hall, Ithaca, New York, 14853.

Four to five pounds of crushed ice per square foot (25 kg per square meter) of display space are required for cooling per day. A catch pail should be provided for melt water. To minimize ice needs, the display tray should be insulated and kept out of the direct sun.

When displaying horticultural crops, single or double layers of produce are most likely to protect the commodities from compression damage and over-handling by the consumers.

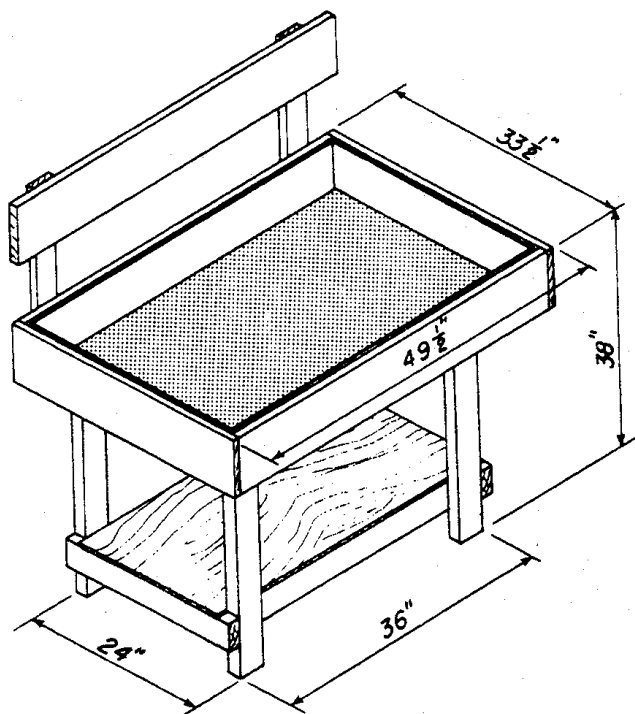

Source: Bartsch, J.A. et al. No date. Construction and management of an iced produce display. Cornell University, Agricultural Engineering Extension Bull. 438.

High relative humidity can be maintained during display by misting leafy vegetables and water tolerant crops with clean, cold water. A simple sprinkler device can be constructed by perforating a pipe with tiny holes and connecting it to a hose. If this display is used outdoors, shade should be provided.

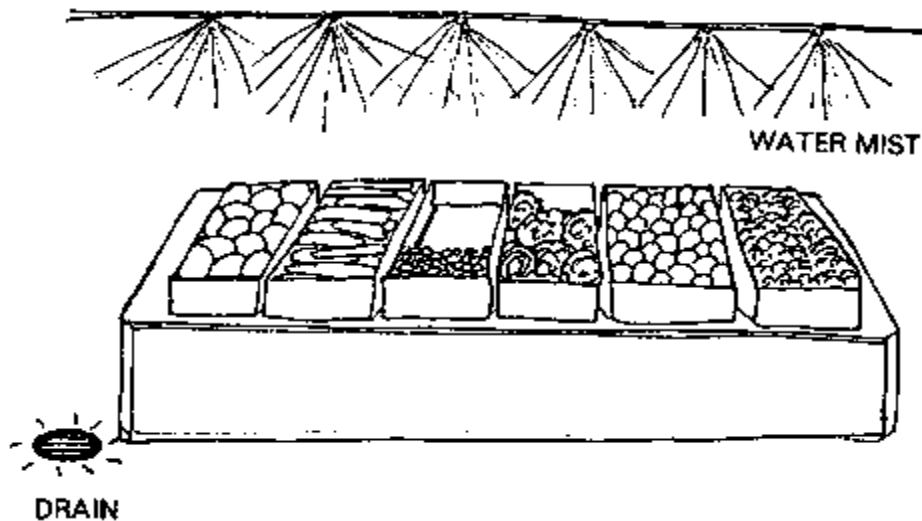

Displays and storage areas must be cleaned and sanitized on a regular basis. Trimmings, waste, and bruised product remaining in displays are unsightly and can be sources of decay, odor and ethylene.

Produce that benefit from misting while being displayed:

|                  |                  |
|------------------|------------------|
| Artichoke        | Mustard greens   |
| Beans (snap)     | Onions (green)   |
| Beets            | Parsley          |
| Broccoli         | Parsnips         |
| Brussels sprouts | Peas             |
| Cabbage          | Peppers          |
| Carrots          | Radishes         |
| Cauliflower      | Rhubarb          |
| Celery           | Shallots (green) |
| Collards         | Sprouts          |
| Corn             | Summer squash    |
| Eggplant         | Swiss chard      |
| Endive           | Turnips          |
| Kale             | Watercress       |
| Lettuce          |                  |

A simple semi-circular display table can be constructed from one standard size (four foot by eight foot) sheet of plywood. Plans for the table illustrated below and for other market stands are available from Cornell University Extension, 304 Riley-Robb Hall, Ithaca, New York 14853.

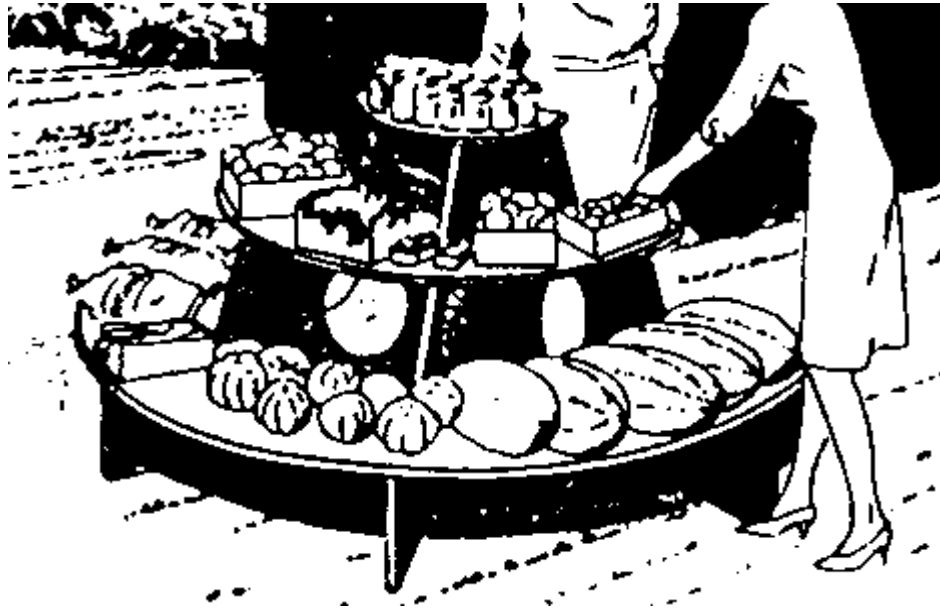

Source: Agricultural and Biological Engineering. No date. Description and Price List of Plans for Storages and Market Stands for Fruit and Vegetables. Cornell University Extension Bulletin 851-S.



## **Chapter 10: Processing of Horticultural Crops**

---

When conditions are not suitable for storage or immediate marketing of fresh produce, many horticultural crops can be processed using simple technologies. There are many processing methods that can be used by small-scale handlers, including drying, fermenting, canning, freezing, preserving and juicing. Fruits, vegetables and flowers can all be dried and stored for use or sale in the future. Fermentation is popular throughout the world as a food preservation method, and over 3,500 individual fermented foods have been described by Campbell-Platt (1987). Fruits and vegetables can be canned or frozen, and fruits are often preserved in sugar or juiced.

Processed products must be packaged and stored properly in order to achieve their potential shelf life of up to one year. Dried products must be packaged in air-tight containers (glass or plastic bottles or sealed plastic bags). Canned and bottled products must be adequately heat-processed using clean, high-quality containers that provide good seals. Dried and canned or bottled products are best stored in a cool, dark place.

Postharvest handling, transport and marketing of processed products can be much simpler and less costly than for fresh products, since refrigeration is unnecessary. Dried products take up much less space and are significantly lighter than their fresh equivalents, further reducing transport and storage costs.

| <b>25 pounds of:</b>        | <b>Yields this much dried product:</b> |
|-----------------------------|--|
| Fruits                      | 4 lb                                   |
| Carrots or beets            | 3 lb                                   |
| Celery, cabbage or tomatoes | 1.5 lb                                 |
| Onions or zucchini          | 2.5 lb                                 |

Source: Bills, J. and Bills, S. 1974. Home Food Dehydrating. Bountiful, Utah: Horizon Publishers

Intermediate Technology Publications\* in association with CTA published a guide to appropriate equipment entitled Small-Scale Food Processing (1992) edited by Fellows and Hampton. UC Davis has an excellent website with many food processing resources website (<http://fruitandvegetable.ucdavis.edu>). We encourage you to use this directory to find more information on the processes introduced in this manual, or to locate specific equipment and local manufacturers.

\* Intermediate Technology Publications, 9 King Street, London WC2E 8HW, UK

## Processing Equipment

A catalog of postharvest processing equipment is available from Intermediate Technology Publications. Included are driers, storage containers, cleaners, hand mills, power mills, shellers, decorticators (seed removers), oil processing equipment, fruit presses, and root crop cutters/graters. Some examples are shown below.

### Two-man cassava grater:

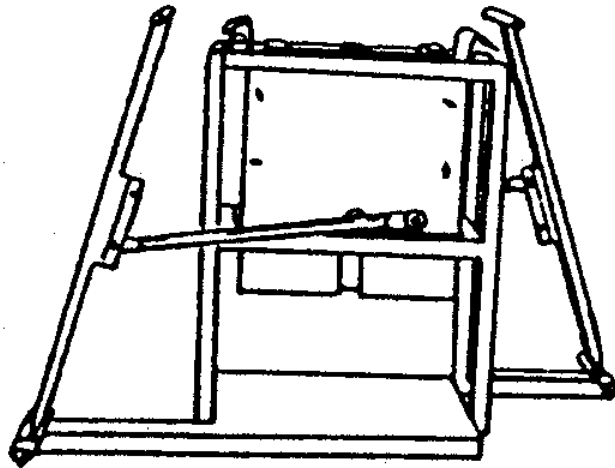

### Four-bladed root chopper:

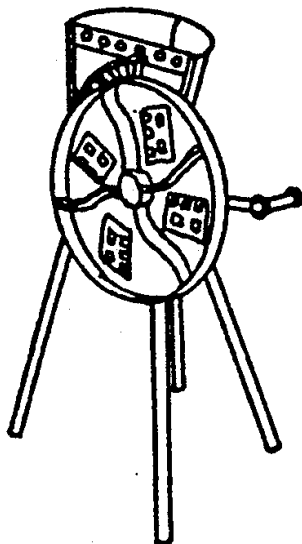

**Hand-operated fruit press:**

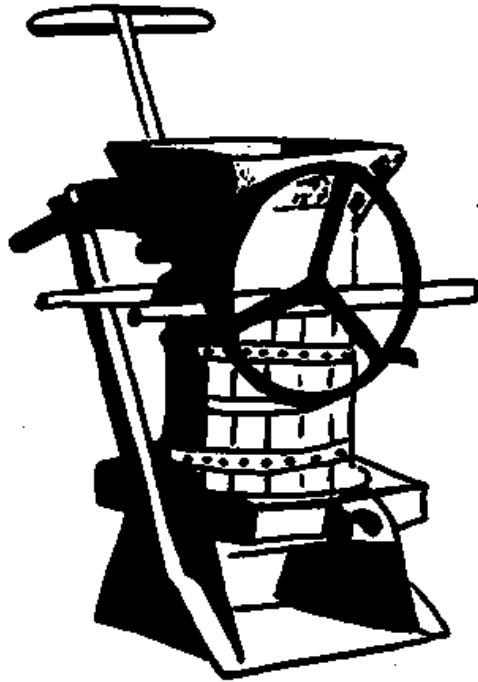

**Cherry pitter:**

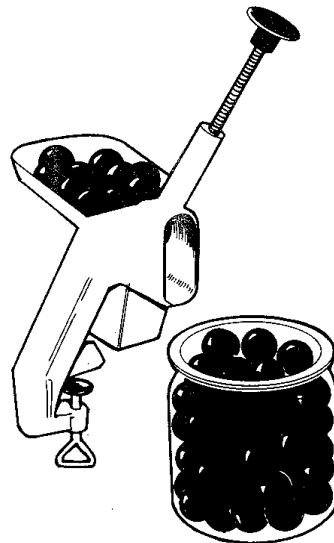

Source: Intermediate Technology Publications, 1987. Post-harvest Crop Processing: Some tools for agriculture. Intermediate Technology Publications. London, England. p. 29.

## Preparation for Processing

Some produce requires blanching before freezing or drying. Blanching, using a boiling water bath or steam ends certain enzymatic reactions in the product and helps retain color and flavor after processing. Always rinse blanched produce under very cold water or dip blanched produce into an ice water bath to stop the cooking process and quickly bring the temperature down.

Blanching times for selected commodities {use one gallon of water per pound (8 L per kg) of produce}. Add one minute for each 2000 ft. (600 m) altitude if you live at elevations over 4000 ft. (1200 m).

| Commodity              | Blanching time in boiling water (minutes) |
|------------------------|---|
| Broccoli               | 3   |
| Green beans            | 3   |
| Cabbage (wedges)       | 5   |
| Carrots                | 5   |
| Cauliflower            | 3 (add 4 teaspoons of salt)               |
| Collard greens         | 3   |
| Corn (sweet)           | 7   |
| Eggplant               | 4 (add 1/2 cup lemon juice)               |
| Leafy greens           | 2   |
| Mushrooms              | 3 to 5                                    |
| Peas                   | 2   |
| Potatoes (new)         | 4 to 10                                   |
| Pumpkin                | 2 to 3 or until soft                      |
| Sweet potatoes         | 15 to 20 or until soft                    |
| Zucchini/summer squash | 3   |

Sources: Chioffi, N. and Mead, S. 1991. Keeping the Harvest. Pownal, Vermont: Storey Publishing.

McClure, S. 1992. The Harvest Gardener. Pownal, Vermont: Storey Publishing.

Fruits such as apples, pears, peaches and apricots are sometimes treated with sulfur before being dried. Sulfuring (burn one tablespoon of sulfur powder per pound (12 g per kg) of fruit) or sulphiting (dip fruit in a 1% potassium meta-bisulfite solution for one minute) helps prevent darkening, loss of flavor and loss of vitamin C.

Sulfur has been a source of allergic reactions in some people, so packages of sulfured product should always be clearly labeled. Vitamin C can be used as an alternative pre-treatment to prevent browning during the drying process. Use 30 mL ascorbic acid powder in one liter (or 2 tablespoons in one quart) of lukewarm water. Slice the fruits directly into the solution, remove with slotted spoon, drain well and pat dry.

For best results when drying fresh produce, fruits should be sliced or quartered, and vegetables should be thinly sliced, chopped or diced. Solar drying of fruits will take 2 to 3 days or longer, while most chopped or diced vegetables will dry in 1 to 2 days.

Sulfuring times for selected fruits:

| <b>Commodity</b> | <b>Sulfuring Time for Quartered Fruits</b> | <b>Sulfuring Time for Halved Fruits</b> |
|------------------|--|---|
| Apples           | 45 minutes                                 |   |
| Apricots         | 2 hours                                    | 3 hours                                 |
| Cherries         | 20 minutes                                 | 30 minutes                              |
| Nectarines       | 2 hours                                    | 3 hours                                 |
| Peaches          | 2 hours                                    | 2 to 3 hours                            |
| Pears            | 2 hours                                    | 4 to 5 hours                            |

Sources: Miller, M. et al. 1981. Drying Foods at Home. University of California, Division of Agricultural Science, Leaflet 2785.

Hobson, P. 1994. Making and using dried foods. Pownal, Vermont: Storey Publishing.

A low-cost sulfuring box can be constructed from a large cardboard box that is slashed in several places to allow adequate ventilation. Trays for drying can be stacked using bricks and wooden spools as spacers. The trays must be made completely of wood; since sulfur fumes will corrode metal. The entire assembly must be located out of doors, preferably on bare soil. Use one tablespoon of sulfur powder per pound (35 mL per kg) of fruit. Place the sulfur in a container well away from the side of the box since it will become quite hot. Seal the bottom edges of the box with soil.

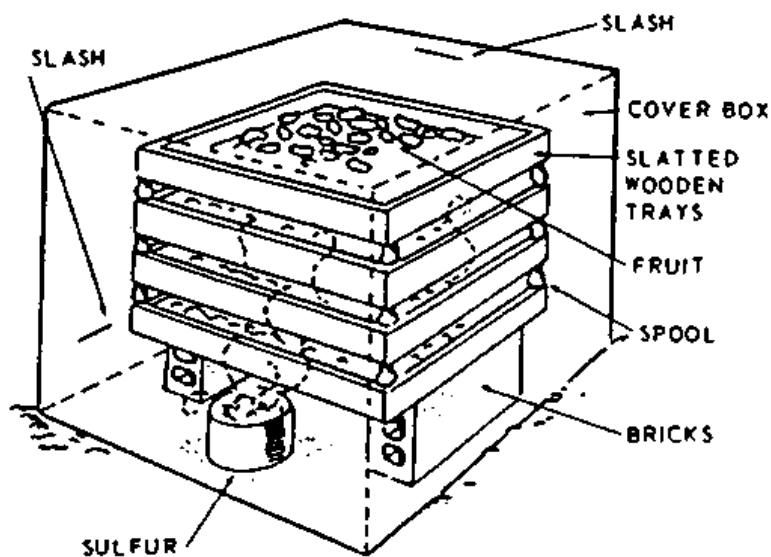

Source: Miller, M. et al. 1981. Drying Foods at Home. University of California, Division of Agricultural Science, Leaflet 2785.

**Wooden box:**

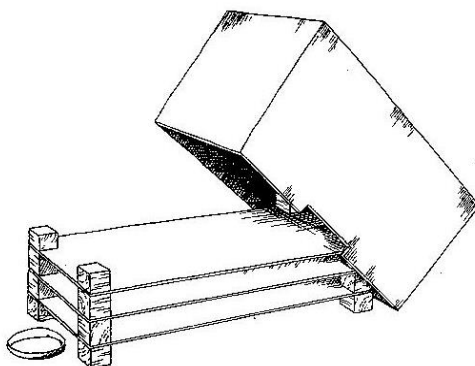

Source: Intermediate Technology Publications, 1987. Post-harvest Crop Processing: Some tools for agriculture. Intermediate Technology Publications. London, England.

## Solar Drying

Horticultural produce can be dried using direct or indirect solar radiation. The simplest method for solar drying is to lay produce directly upon a flat black surface and allow the sun and wind to dry the crop. Nuts can be dried effectively in this way.

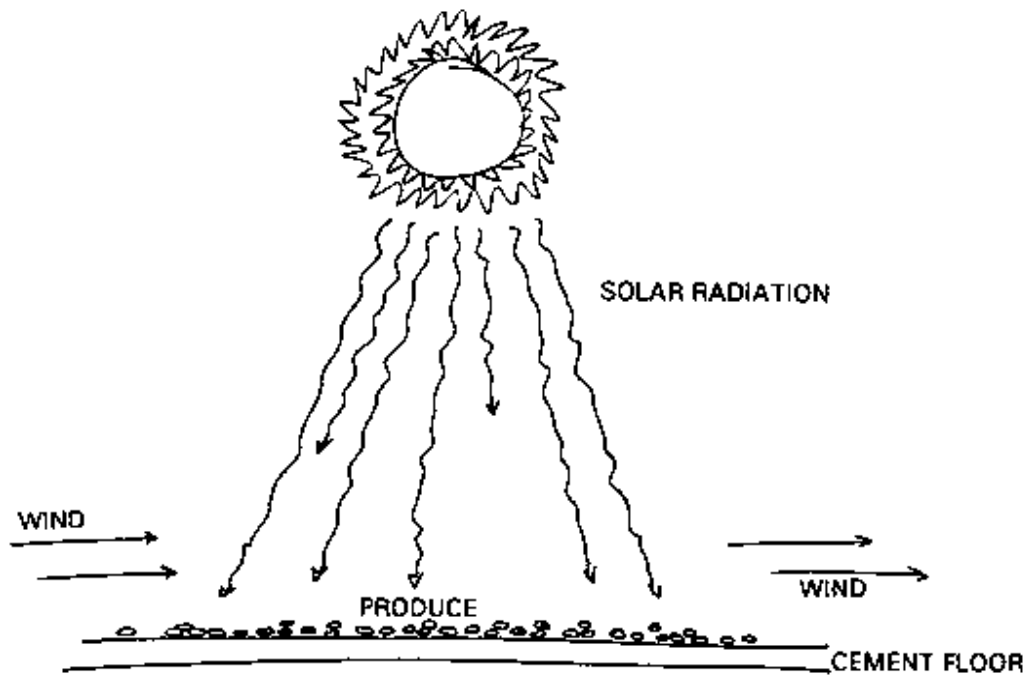

Simple direct driers can be made from trays of screening material propped upon wooden or concrete blocks to allow air to circulate under the produce. A layer of cheesecloth can be draped loosely over the produce, protecting it from insects and birds while drying. Check the produce each day, and move it under cover if rain threatens.

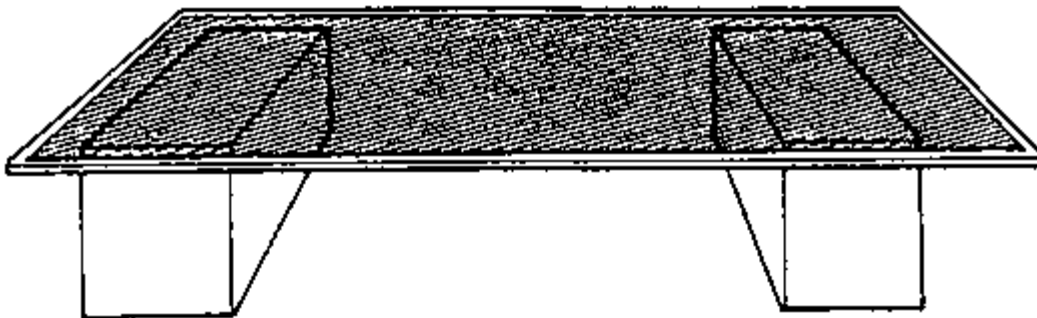

A simple method for solar drying is to construct a raised platform from wood and cover the frame with loosely woven mats. In the illustration below, sliced fresh tomatoes are being dried in direct sunlight on straw mats. Air can pass over and below the produce, speeding drying and reducing losses due to overheating.

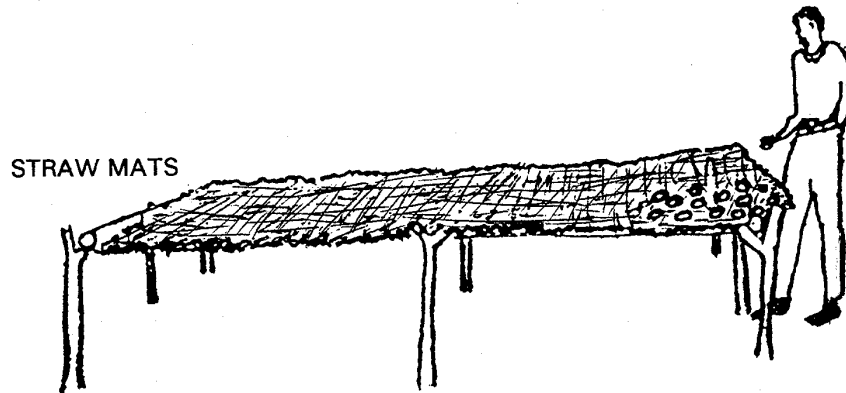

Source: Kitinoja, L. 1992. Consultancy for Africare/ USAID on food processing in the Ouadhai, Chad, Central Africa. Woodland, CA: Extension Systems International

Aluminum foil can be utilized to reflect the sun onto the drying trays. The example shown below uses a plastic sheet to trap some of the heat and speed the drying time.

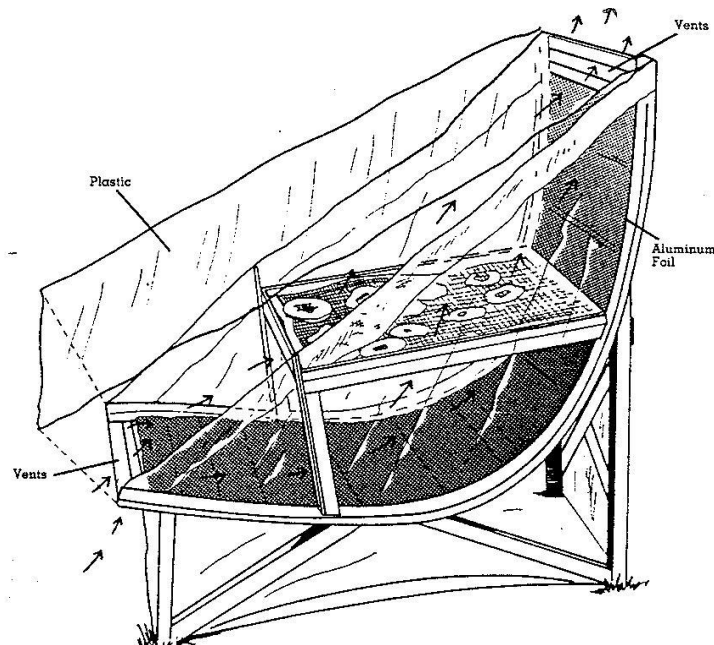

Source: Intermediate Technology Publications, 1987. Post-harvest Crop Processing: Some tools for agriculture. Intermediate Technology Publications. London, England. p. 29.









All the trays, screens or mats used for drying produce must be kept **clean**. Trays made from stainless steel, plastic or nylon are much easier to keep clean than are wooden trays. Some fruits juices will adhere to the surfaces with each handling. This leads to an accumulation of dirt and buildup of mold that can contaminate and affect the appearance and quality of the dried product. Use a strong detergent and a stiff brush to scrub the trays, screens or mats clean. Allow them to dry in the sun before using them to dry product.

A good material for settling dust on roads, paths or earthen floors is calcium chloride ( $\text{CaCl}_2$ ). When spread on the earth it absorbs moisture from the air and keeps the soil moist. Rake the calcium chloride into the surface at a rate of  $\frac{1}{2}$  pound per square yard.

To reduce mold growth on trays, screens and mats during the off season, wash and dry them thoroughly, then store them in a well-ventilated area.

Source: Mrak, E.M. and Phaff, H.J. 1949. Sun-drying fruits. California Agricultural Experiment Station Circular 392.

In order to improve the efficiency of drying, some sort of structure must be used to capture solar radiation. Various types of solar driers have been developed and are illustrated below.

| Drier type                   | Description   | Schematic view of typical example   |
|------------------------------|---|---|
| Direct cabinet               | Drying Chamber is glazed and no separate solar collector is used.   |    |
| Indirect cabinet             | Solar collector is used which is separate from the drying chamber, which has no transparent surfaces.   |    |
| Mixed mode or Hybrid cabinet | Drying chamber is partially or fully glazed, and a separate solar collector is used.  |    |
| Tunnel                       | Usually a hoop framed structure with one or two layers of film plastic glazing. Usually a direct drier, but can be indirect if black plastic film is used for the inner layer of glazing. |   |
| Low tunnel                   | Direct drier similar to the above but built close to the ground, and usually able to hold only one layer of produce.  |  |
| Tent                         | Direct drier with straight rather than curved frame members.  |  |
| Bin                          | Any drier, but usually indirect with forced convection air flow, which can dry deep layers (typically 300 mm or more) of the produce.   |  |

\* indicates glazed surface

Source: Fuller, R.J. 1993. Solar Drying of Horticultural Produce: Present Practice and Future Prospects. Postharvest News and Information 4(5): 131N-136N.

More complex models of solar driers have glass or clear plastic windows that cover the produce, providing some protection from insects while capturing more of the heat of the sun.

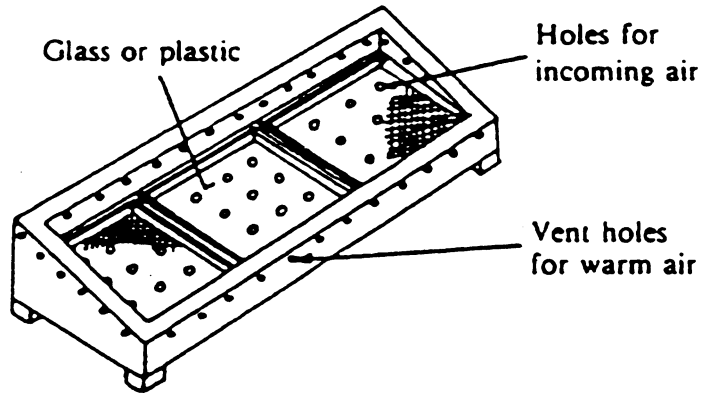

**Direct solar driers:**



Simple Design



With Reflector

**Indirect Driers** are constructed so the sun shines upon a solar collector (a shallow box, the insides painted black, topped with a pane of glass) heating air which then moves upward through a stack of four to six trays loaded with produce.

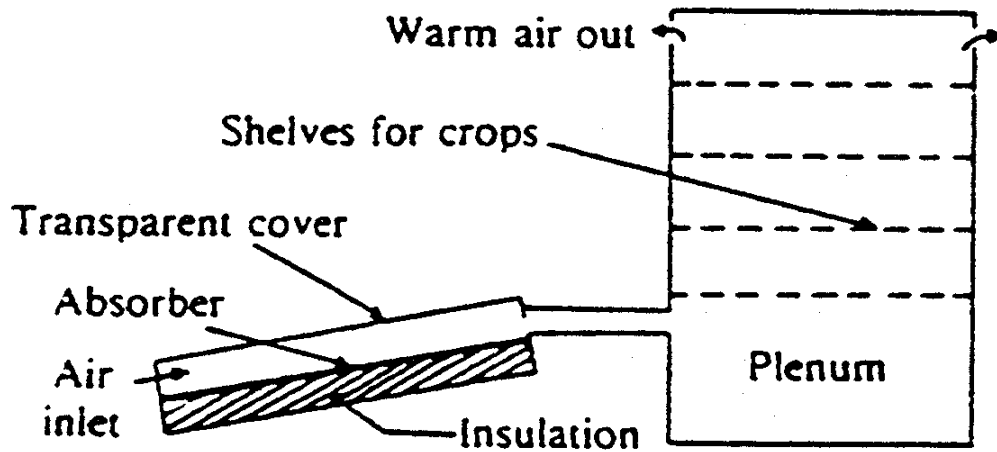

Source: Yaciuk, G. 1982. Food Drying: Proceedings of a Workshop held at Edmonton, Alberta, 6-9 July 1981. Ottawa, Ontario: IDRC p. 104.

## Forced-air Dehydrators

Nut crops can be dried in bulk using a dehydrator that combines a steady stream of dry air with an external source of heat. The plenum chamber below the produce is covered with a floor of perforated sheet metal or wooden slats. A fan located between the furnace and the plenum chamber moves the hot air through the drying produce.

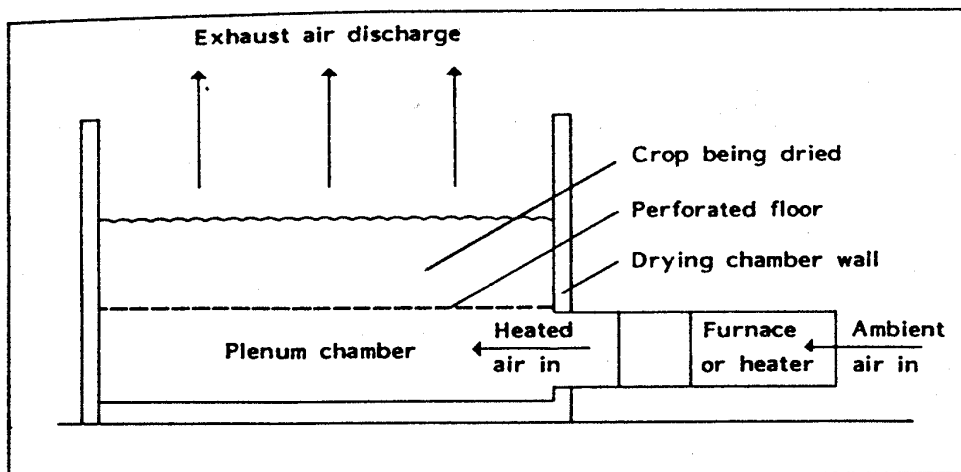

Source: FAO. 1985. Prevention of Post-Harvest Food Losses: A Training Manual. Rome: UNFAO. 120 pp.

## Oil-burning Dehydrators

The batch-dryer illustrated below is constructed of wood, has an axial type of fan and burns kerosene or diesel oil. A wide variety of dryers are available from manufacturers around the world.

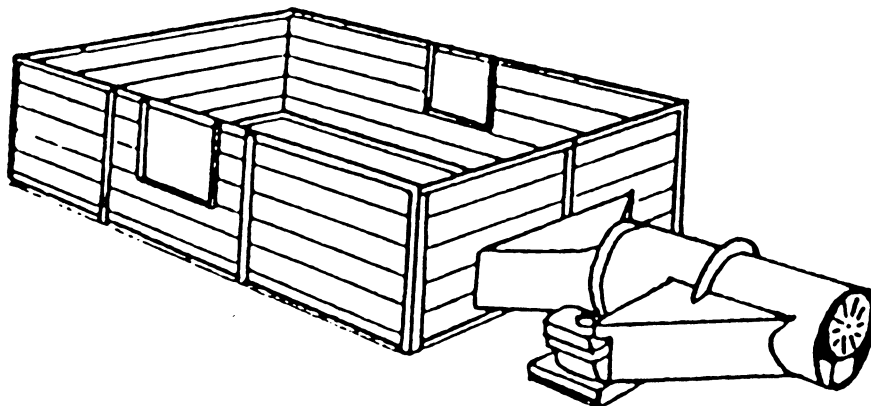

Source: Clarke, B. 1987. Post-Harvest Crop Processing: Some Tools for Agriculture. London, UK: Intermediate Technology Publications.

Two types of dehydrators are commonly used for drying small volumes of nut crops. A wagon with a perforated floor can be transported from the field and connected to a portable burner batch drying. A stationary "pot-hole" dehydrator is designed to move heated air along a plenum under a fixed platform. Individual bins of nuts are placed upon the platform and are dried as heat rises up through the perforated floor.

**Wagon Dehydrator:**

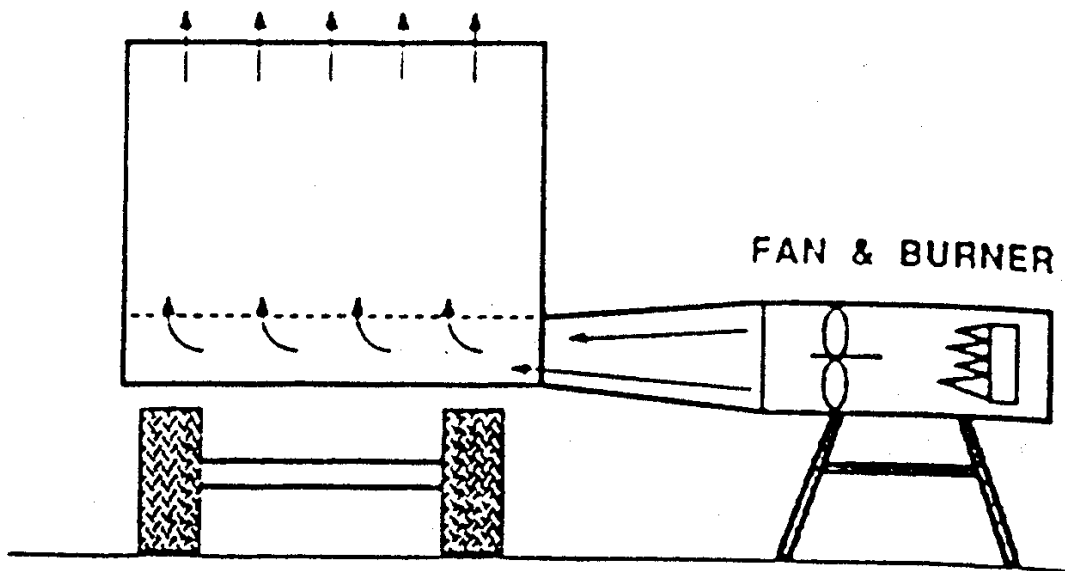

**Pot-Hole Dehydrator:**

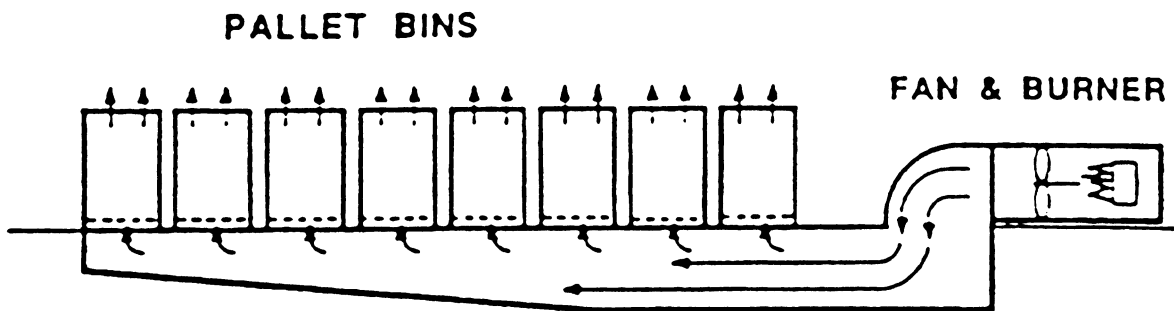

Source: Kader, A.A. and Thompson, J.F. 2002. Postharvest handling Systems: Tree nuts. p.399-406. In: Kader, AA. (Ed). Postharvest Technology of Horticultural Crops. University of California, Division of Agriculture and Natural Resources, Publication 3311.

## Electric Dehydrators

A simple electric dehydrator can be constructed using plywood, sheet metal, a small fan, five household light bulbs with porcelain mounting fixtures, and some screening material. The drier shown below is 32 inches long by 21 inches wide and 30 inches high, and contains racks for five trays. The fan and the sheet metal lining the bottom compartment help conduct heat upward through the box.

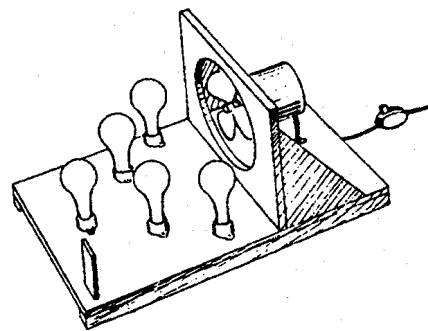
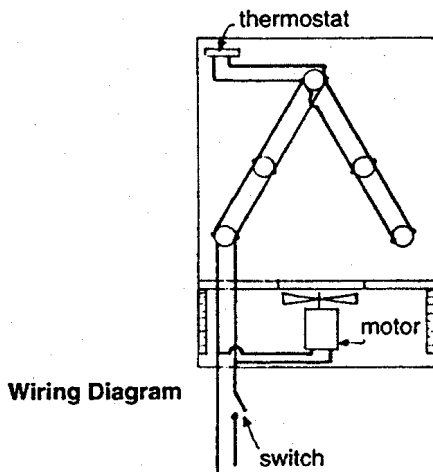
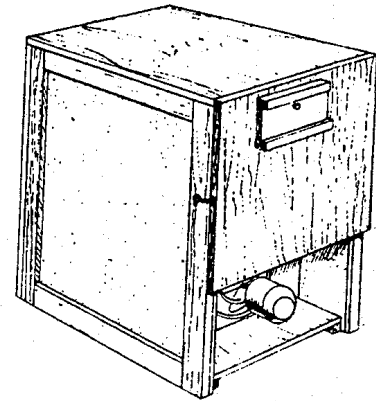
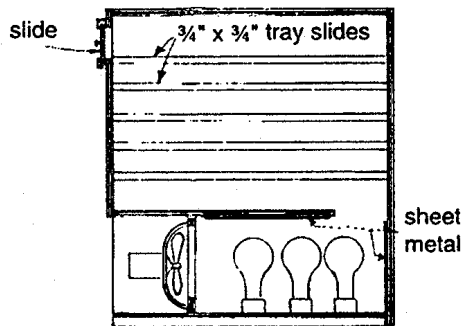

Source: Chioffi, N. and Mead, G. 1991. Keeping the Harvest. Pownal, Vermont: Storey Publishing

## Oven Drying

Fruits and vegetables can be dried in a home oven if the oven can be run at a low temperature. Place the prepared produce on baking or metal screen trays, set the oven temperature at 60 °C (140 °F) and leave the door ajar (2 to 4 inches/ 5 to 10 cm). Drying time can be reduced if ventilation is increased by using a small fan placed outside the oven.

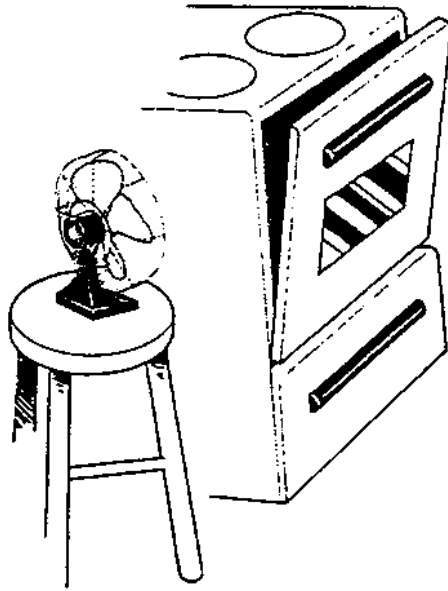

Source: Georgia Cooperative Extension Service. 1984. So Easy to Preserve. University of Georgia, Athens, Georgia.



## Solar Ovens

Solar ovens can be an inexpensive method for cooking or drying produce, and you could buy one for about \$100 or make it yourself by following the simple instructions on these videos. The boxes can be made from wood, cardboard, plastic or any material since the oven is then lined with aluminum foil or painted a reflective silver color.

<http://www.youtube.com/watch?v=sne80sXV-YU>

<http://www.solarovens.org/index.html>

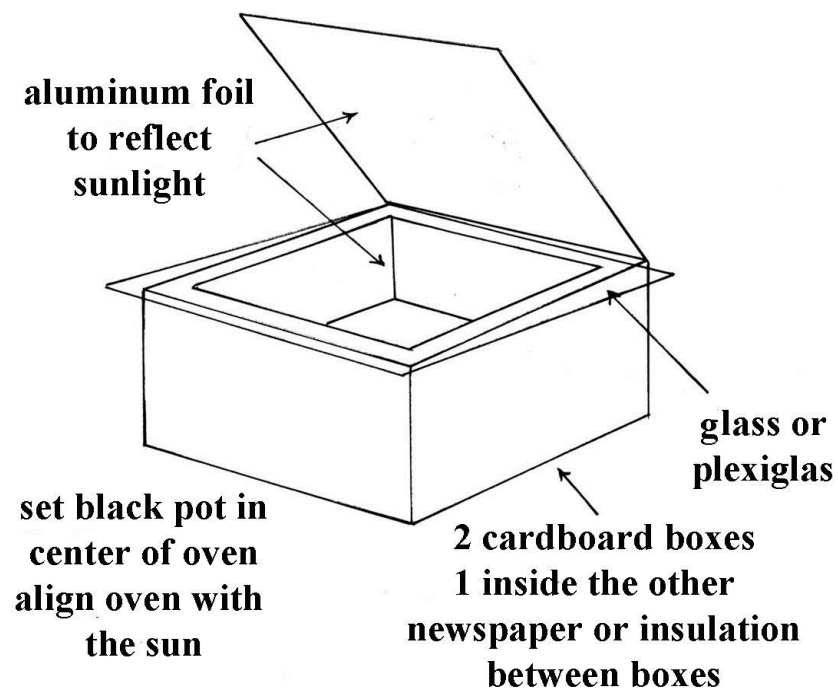

Source: <http://preparednessadvice.com/solar/solar-oven-cooking/#.UmgOJvbkqBM>

## Drying Flowers

Cut flowers can be air dried by hanging upside down or while supported by chicken wire. Certain flowers will look more natural if left standing in a vase while they dry. *Anthurium* dries best if left to dry very slowly. Cut the stems at a sharp angle, and place the flowers into a vase containing two inches of water. In all cases, flowers should be left to air dry in a dark, well area.

Flowers that dry best if left standing: strawflower, delphinium, larkspur, okra pods

Flowers that dry best while hanging upside down: *Chysanthemum*, *Amaranthus*, African daisy, statice, marigold

**African daisy supported on a screen of chicken wire:**

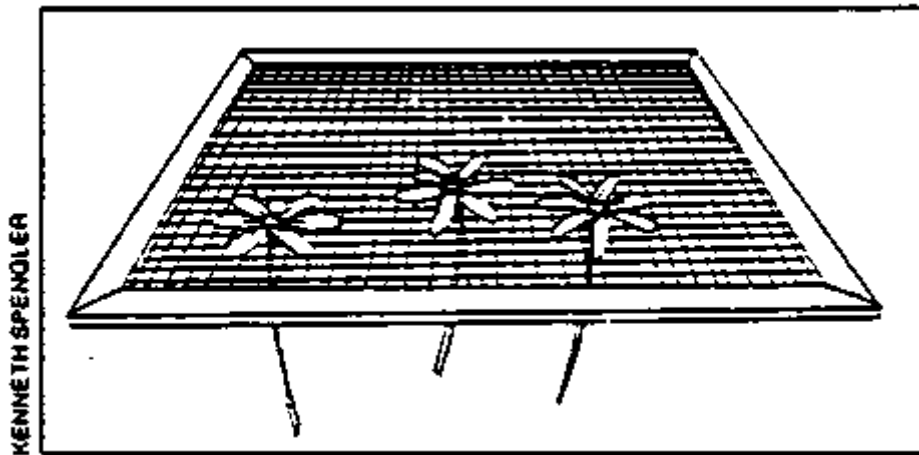

Source: Rogers, B.R. 1988. The Encyclopedia of Everlastings. New York: Michael Friedman Publishing Group, Inc. p. 191.

Cut flowers can be dried quickly and easily in sand or silica gel. Sand used for drying flowers should be clean, smooth and the finer the better. Starting with one inch (2.5 cm) of sand in a container, place the flower to be dried on the sand and gently cover the entire flower with more sand. The container should be left uncovered and flowers should be dried in about three weeks. Flowers that dry well in sand are shasta daisy, lily-of-the-valley, cosmos, dahlia, sweet William, carnation, stock, freesia and narcissus.

#### Drying flowers in sand:

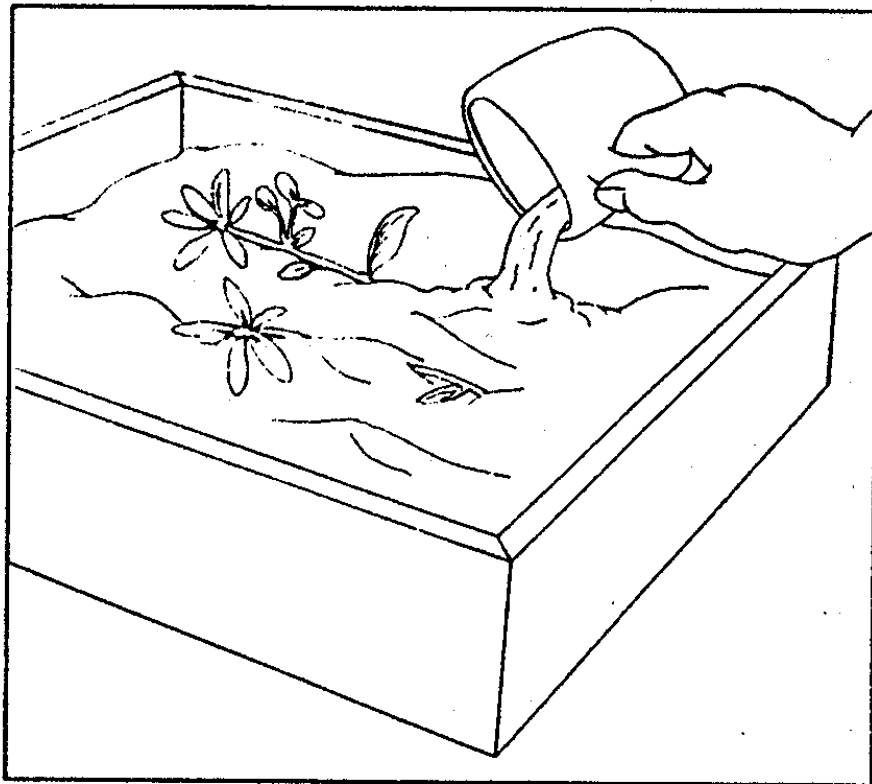

Silica gel is relatively expensive but reusable if heated to dry out the gel between uses. To use, cover the flower as with sand, then tightly seal the container. Check for drying in two to three days. Silica gel is especially useful for drying fragile plants and flowers with delicate colors.

Flowers that dry best in silica gel are allium, anemone, cornflower, roses, tulip and zinnia.

Source: Rogers, B.R. 1988. The Encyclopedia of Everlastings. New York: Michael Friedman Publishing Group, Inc. p. 191.

## Canning

Two types of canners are commonly used to process horticultural crops. The first is a water bath canner, which is a large pot with a loose cover and a rack to hold jars off the bottom. The pot should be deep enough to cover the canning jars by one to two inches and still have another inch of space to allow brisk boiling. The diameter of the pot should be no more than four inches wider than the diameter of the stove's burner to ensure even heating.

Acidic foods such as fruits, tomatoes, pickles and relishes, and high sugar foods such as jams, jellies, syrups and marmalades can be safely processed using a boiling water bath.

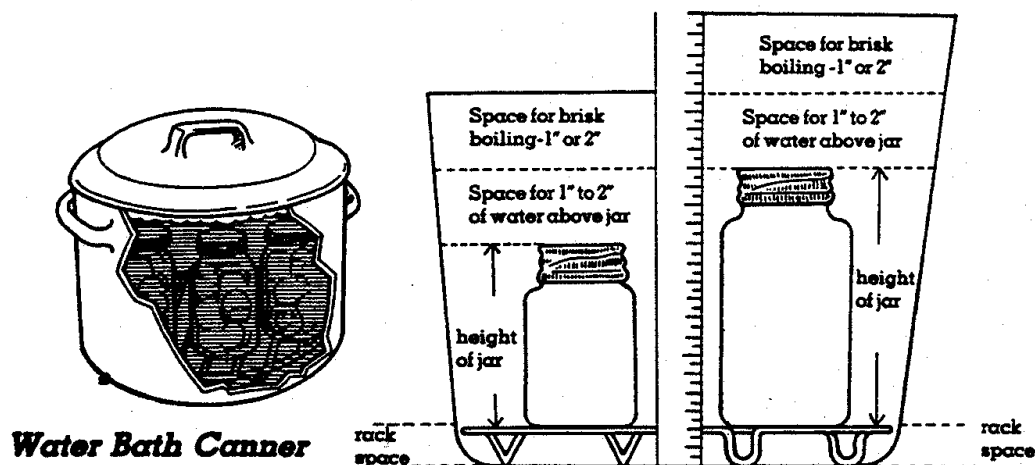

Source: Georgia Cooperative Extension Service. 1984. *So Easy to Preserve*. University of Georgia, Athens, Georgia.

More canning resources:

1) National Center for Home Food Preservation

Offers a free, self-paced, online course for those wanting to learn more about home canning and preservation:

Introduction to Food Preservation

General Canning

Canning Acid Foods

Canning Low-Acid Foods

2) This course is offered in the University of Georgia eLC system. UGA requires registration for you to receive a login. <http://nchfp.uga.edu/index.html>

<http://nchfp.uga.edu/educators/yesyoucan.jpg> (canning basics poster)

3) Websites for recipes <http://www.canningpantry.com/jams-jellies-fruitspreads.html>

Easy recipes for canning fruits, drying tomatoes, making jams, pickles, etc.

<http://puttingby.wordpress.com/>

A pressure canner is recommended for processing low-acid foods such as vegetables. A pressure canner is a specially made heavy pot with a locking lid, an inner rack and a steam vent in the lid. The vent can be adjusted using a weight, value or screw, depending on the type of canner. A pressure gauge registers the air pressure inside the canner. A dial gauge gives a reading of the actual pressure, while weighted gauges will rock gently when the canner is at the proper pressure. Ten pounds of pressure at 115 °C (240 °F) is recommended for canning vegetables.

**Pressure Canners**

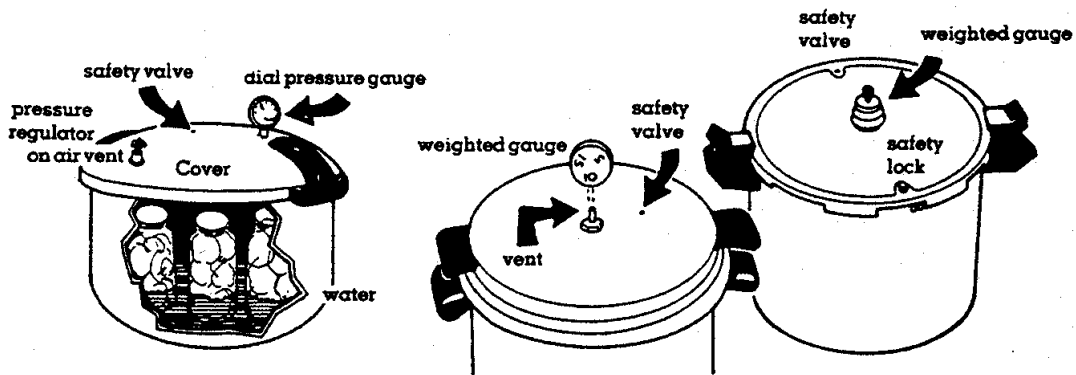

**Dial Gauge**

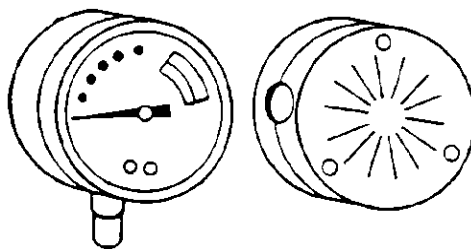

**Weighted Gauges**

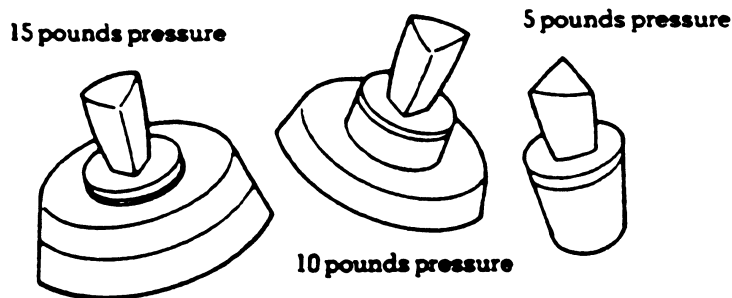

Source: Georgia Cooperative Extension Service. 1984. So Easy to Preserve. University of Georgia, Athens, Georgia.

There are three types of glass canning jars used for processing horticultural crops. The ball type jar and the zinc capped jar both require rubber rings as seals. These can sometimes be difficult to obtain, but if locally available, make excellent containers. Currently, the canning jar with a two-piece lid is the most commonly used container.

No matter which jar is used, when filling containers, it is important to leave a small amount of headspace to allow for expansion of the food while processing. If a jar is filled too full, it may explode. If too much headspace is left, the food may spoil, since all the extra air may not be driven out during processing.

**Canning jars and lids, L to R: ball type jar, zinc lid and two-piece**

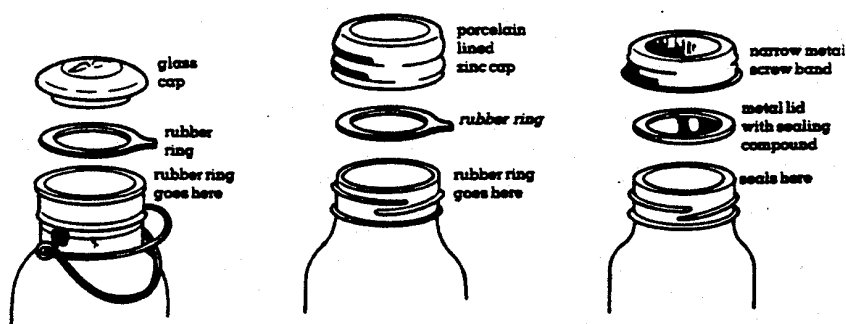

***Canning jars and lids, L to R: ball type jar, zinc lid and two-piece***

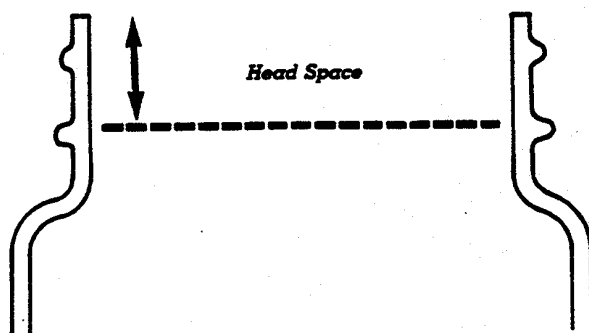

Source: Georgia Cooperative Extension Service. 1984. So Easy to Preserve. University of Georgia, Athens, Georgia.

## Juicing

### Fruits

To process tomatoes or fruits into juices, the fruits are simmered in water or their own juice in a stainless steel, glass or enamelware pot. When tender, the product is cut into pieces and pressed through a food mill, colander or several layers of cheesecloth. Sugar or lemon juice can be added, to taste.

The juices must then be either frozen or canned for storage. Juices can be frozen in jars or freezer containers (leave 1.5 cm or 1/2 inch headspace). Most fruit juices can be canned in a boiling water bath for 20 minutes, but apple and grape juices can be processed in hot water (82 °C or 180 °F) for 30 minutes.

### Vegetables

Vegetables should be chopped or shredded, then simmered for 45 to 50 minutes until mushy. The juice can then be pressed or strained from the vegetable pulp, and frozen or canned. Canning vegetable juices requires processing at ten pounds of pressure in a pressure canner. Pints should be processed for 55 minutes, and quart jars for 85 minutes.

Source: Stoner, C.H. (Ed). 1977. Stocking Up. Emmaus, Penn: Rodale Press.

## **Other Methods of Processing**

### **Freezing**

Most vegetables should be blanched before freezing to prevent loss of flavor and color during storage. Freezing temperatures are best set between -21 to -18 °C (0 to 5 °F).

Packages for freezing should be moisture-proof and vapor-proof and contain as little air as possible to prevent oxidation during storage. Heavy plastic bags, heavy aluminum foil, glass freezer jars and waxed freezer cartons all make good containers.

### **Jellies, Jams and Preserves**

Making jams, jellies and other high-sugar preserves requires a balance of fruit, acid, pectin and sugar for best results. Under-ripe fruits contain more pectin than ripe fruits, and apple juice is a good source of natural pectin. If fruits are low in acid, lemon juice can be added to the mixture of fruit and sugar. Cane or beet sugar is better for making preserves than honey or corn syrup.

To preserve fruits, cook on medium heat until the mixture "sheets" from a spoon. Avoid overcooking since this will lower the jelling capacity of the mixture. Pour into containers and seal with paraffin wax (jellies only). The other preserves should be processed in a boiling water bath for five minutes.

### **Fermentation**

When lactic acid bacteria in foods convert carbohydrates to lactic acid, food is preserved by the resulting low pH. Sauerkraut (cabbage) and wine (grapes) are two examples of thousands of fermented foods made around the world. For more information and recipes, see Chioffi and Mead (1991).

### **Acidification**

Pickling is a simple processing method that can be used with many types of fruits and vegetables. Brine solution (9 parts cider or white vinegar, 1 part non-iodized salt, 9 parts water, plus flavorings and spices) is poured over the product into glass canning jars (leave 1/2 inch headspace). Brined pickles are sealed and left at ambient temperature for three or more weeks, while fresh pack pickles are processed in a boiling water bath for 10 minutes.

Source: USDA. 1977. Canning, Freezing and Storing Garden Produce. USDA Agricultural Information Bulletin 410.



## Oil Extraction

Oregon State University has developed a simple method for extraction of essential oils in your microwave. Visit the website <http://oilextech.com/> for a demonstration of the device.



*This kit is placed in the microwave for 6-8 minutes; it uses ice to condense the steam/oil vapors created from the plant material.*

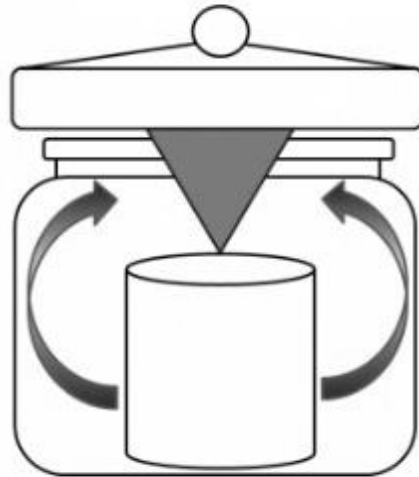

Source: Velasco, Carmen. Hackleman, David. Microwave Extraction of Peppermint Oil and Comparison to the Current Practice of Steam Extraction. Department of Chemical Engineering, Oregon State University, Corvallis OR.  
[http://ir.library.oregonstate.edu/xmlui/bitstream/handle/1957/6487/Carmen\\_Velasco\\_Thesis.pdf?sequence=1](http://ir.library.oregonstate.edu/xmlui/bitstream/handle/1957/6487/Carmen_Velasco_Thesis.pdf?sequence=1)

## **Chapter 11: Food Safety Practices**

---

Concerns about food safety when handling fresh fruits and vegetables have increased over the past decades. Recent outbreaks of food-borne disease have been associated with berries, tomatoes, leafy greens, fresh herbs and cut fruits. Wholesale buyers and consumers are increasingly interested in the use of handling practices that will ensure food safety. It is the responsibility of growers and postharvest handlers to document their food safety practices in order to protect fresh produce from contamination. Retailers, such as large supermarket chains, are demanding compliance with food safety practices from their suppliers. It is nearly impossible to export produce to Europe or the U.S. without documenting its safe handling from the farm to the market.

Some general food safety practices are being promoted by universities, governmental agencies and private sector organizations around the world. For growers who want to export their produce to the European Community (EC), you should be aware that standards are being enforced by the retail produce industry to guide handling practices for growers and shippers (known as GlobalGAP). Key concepts are the implementation of GAP (Good Agricultural Practices) on the farm, in the packinghouse and during transport of all fresh produce, and HACCP (Hazard Analysis Critical Control Points) to document the safe handling of farm chemicals, pesticides, packaging materials, etc., especially for processed or fresh-cut produce.

Most small-scale packinghouses will require new water systems and improved sanitation practices. Current information can be found on the internet ([http://www2.globalgap.org/fruit/index\\_html](http://www2.globalgap.org/fruit/index_html)).

Guidelines for U.S. growers have been published by various sources. A copy of the publication: "Food safety begins on the farm: A grower's guide" can be obtained at no cost from Cornell University's Good Agricultural Practices Program or downloaded as a pdf file from their website.

<https://ecommons.cornell.edu/handle/1813/2209>

The typical causes and sources of food safety problems during production and postharvest handling fall into the following three major categories.

**Physical Hazards:** Examples of physical hazards which may become imbedded in produce during production handling or storage are such things as:

- fasteners (staples, nails, screws, bolts)
- pieces of glass
- wood splinters

**Chemical Hazards:** Examples of chemical hazards which may contaminate produce during production handling or storage are such things as:

- pesticides, fungicides, herbicides, rodenticides
- machine lubricants from forklifts or packing line equipment
- heavy metals (Lead, Mercury, Arsenic)
- industrial toxins
- compounds used to clean and sanitize equipment

**Human Pathogens:** There are four main types of human pathogens associated with fresh produce:

- soil associated pathogenic bacteria (*Clostridium botulinum*, *Listeria monocytogenes*)
- feces associated pathogenic bacteria (*Salmonella spp.*, *Shigella spp.*, *E. coli* O157:H7 and others)
- pathogenic parasites (*Cryptosporidium*, *Cyclospora*)
- pathogenic viruses (Hepatitis, Enterovirus).

Many of these pathogens are spread via a human (or domestic animal) to food to human transmission route. Handling of fruits and vegetables by infected field-workers or consumers, cross contamination, use of contaminated irrigation water, use of inadequately composted manure or contact with contaminated soil are just a few of the ways that transmission of human pathogens to food can occur.

While produce quality can be judged by outward appearance on such criteria as color, turgidity and aroma; food safety cannot. Casual inspection of produce cannot determine if it is in fact safe and wholesome to consume. Management of growing and postharvest handling conditions are paramount in preventing the contamination of fresh produce by physical hazards, harmful chemicals and human pathogens.

Source: Gorny, J.R. 1999. Chapter 10: Food Safety for fresh horticultural produce. In : Kitinoja, L. and Gorny, J.R. Small-Scale Postharvest Technology: Economic Opportunities, Quality and Food Safety. Postharvest Horticulture Series No.21, Department of Pomology, University of California, Davis.

## Food Safety on the Farm

Practices related to these four simple principles can reduce the risk of produce contamination on the farm.

### Clean soil

- Avoid the improper use of manure.
- Compost manure completely to kill pathogens, and incorporate it into soil at least two weeks prior to planting.
- Keep domestic and wild animals out of fields to reduce the risk of fecal contamination.
- Provide portable toilet facilities\* near the field.
- Prevent run-off or drift from animal operations from entering produce fields.
- DO NOT harvest produce within 120 days of a manure application.

### Clean water

- Test surface water that is used for irrigation for fecal pathogens on a regular basis, especially if water passes close to a sewage treatment or livestock area.
- Keep livestock away from the active recharge area for well-water that will be used for irrigation.
- Keep chemicals away from the active recharge area for well-water that will be used for irrigation.
- Filter or use settling ponds to improve water quality.
- Where feasible, use drip irrigation to reduce crop wetting and minimize risk.
- Use potable water for making up chemical pest management sprays.

### Clean surfaces

- Tools and field containers must be kept clean. Wash and sanitize these items before each use.

### Clean hands

- Workers who harvest produce must wash their hands after using the toilet.
- Provide soap, clean water and single-use towels in the field and insist that all workers wash their hands before handling produce.

\* (For information on obtaining portable toilet facilities, contact the Portable Sanitation Association International at (800) 822-3020.)

Proper hand-washing is an effective strategy for reducing risk of contamination, but food safety experts have observed that few people wash their hands properly. Cornell's Good Agricultural Practices Program provides the following steps:

- Wet hands with clean, warm water, apply soap and work up a lather.
- Rub hands together for 20 seconds.
- Clean under the nails and between the fingers. Rub the fingertips of each hand against the palm of the opposite hand.
- Rinse under clean, running water.
- Dry hands with a single use towel.

Source: Cornell University GAPs Program. 2000. Reduce Microbial contamination with Good Agricultural Practices.

## Minimizing Pathogen Contamination During Harvest

During harvesting operations field personnel may contaminate fresh fruits and vegetables by simply touching them with an unclean hand or a dirty knife blade. Portable field latrines as well as hand wash stations must be available and used by all harvest crew members. Monitoring and enforcement of field worker personal hygiene practices such as washing hands after using the latrine or toilet are a must, to reduce the risk of human pathogen contamination. Workers who are ill with hepatitis A or who have symptoms of nausea, vomiting or diarrhea should not be assigned to harvest fresh produce.

Produce once harvested should not be placed upon bare soils before being placed in clean and sanitary field containers. Field harvesting tools and gloves should be clean and sanitary and should not be placed directly in contact with soil. Field containers should be cleaned and sanitized on a regular basis as well as being free of contaminants such as mud, industrial lubricants, metal fasteners or splinters. Do not allow workers to stand in field bins during harvest to reduce pathogen spread by shoes.

Plastic field bins and totes are preferred over wooden containers since plastic surfaces are easier to clean and sanitize, which should be done after every use. If containers are not cleaned and sanitized after every use, they may become contaminated and then contaminate the next products which are placed in the container. Wooden containers or field totes are almost impossible to sanitize since they have a porous surface and wooden or metals fasteners such as nails from wooden containers may accidentally be introduced into produce. Cardboard field bins if reused should be visually inspected for cleanliness and lined with a polymeric plastic bag before reuse to prevent the risk of cross contamination.

Depending upon the commodity, produce may be field packaged in containers that will go all the way to the destination market or be temporarily placed in bulk bins, baskets or bags which will be transported to a packing shed. Employees, equipment, cold storage facilities, packaging materials and any water which will be contacting the harvested produce must be kept clean and sanitary to prevent contamination.

Source: Gorny, J.R. 1999. Chapter 10: Food Safety for fresh horticultural produce. In : Kitinoja, L. and Gorny, J.R. Small-Scale Postharvest Technology: Economic Opportunities, Quality and Food Safety. Postharvest Horticulture Series No.21, Department of Pomology, University of California, Davis.

## Minimizing Pathogen Contamination During Postharvest Handling

### Employee Hygiene

Gloves, hairnets and clean smocks are commonly worn by packinghouse employees in export-oriented packing sheds. The cleanliness and personal hygiene of employees handling produce at all stages of production must be managed to minimize the risk of contamination. Adequate bathroom facilities and hand wash stations must be provided and used properly to prevent contamination of produce by packinghouse employees. Shoe or boot cleaning stations may also be in place to reduce the amount of field dirt and contamination which enters the packing shed from field operations. Employee training regarding sanitary food handling practices should be done when an employee is hired and reviewed before they begin work each season.

### Equipment

Food contact surfaces on conveyor belts, dump tanks etc. should be cleaned and sanitized on a regular scheduled basis with food contact surface approved cleaning compounds. A 200 ppm sodium hypochlorite (NaClO - bleach) solution is an excellent example of a food contact surface sanitizer. Sanitizers should be used only after thorough cleaning with abrasion to remove organic materials such as dirt or plant materials. **Use of steam to clean equipment should be avoided** since steam may actually cake organic materials and form a biofilm, which renders equipment almost impossible to sanitize. Steam may also aerosolize bacteria into the air and actually spread contamination throughout the packing house facility.

### Packaging materials

All packaging materials should be made of food contact grade materials to assure that toxic compounds in the packaging materials do not leach out of the package and into the produce. Toxic chemical residues may be present in some packaging materials due to use of recycled base materials. Empty packages such as boxes and plastic bags should be stored in an enclosed storage area to protect them from insects, rodents, dust, dirt and other potential sources of contamination. These actions protect not only against the potential loss of valuable materials but also protect the integrity and safety of these materials.

### Wash and Hydrocooling Water

All water which comes in contact with produce for washing or hydrocooling must be safe to drink. Water should contain between 100 and 150 ppm total chlorine and have a pH of between 6 and 7.5. Chlorine use prevents the potential for cross contamination of all produce in the washing or hydrocooling system, **it will not sterilize the produce**. Change the water in dump tanks and hydro-coolers regularly.

For more information about water disinfection, see publications by Trevor Suslow under the “Publications Organized by Topic” section of the “<http://postharvest.ucdavis.edu>” Internet site.

### Ice for cooling

Use ice made from only potable water sources.

### Refrigerated Transport

Produce is best shipped in temperature controlled refrigerated trucks. Pre-cool the vehicles prior to loading. Maintaining perishables below 5 °C (41 °F) even while being transported to destination markets will extend shelf-life and significantly reduce the growth rate of microbes including human pathogens. Temperatures used for transporting chilling-sensitive produce will not protect against the growth of most pathogens. Trucks used during transportation should be cleaned and sanitized on a regular basis. Trucks which have been used to transport live animals, animal products or toxic materials should never be used to transport produce.

#### Sources:

Gorny, J.R. 1999. Chapter 10: Food Safety for fresh horticultural produce. In : Kitinoja, L. and Gorny, J.R. Small-Scale Postharvest Technology: Economic Opportunities, Quality and Food Safety. Postharvest Horticulture Series No.21, Department of Pomology, University of California, Davis.

Cornell University GAPs Program. 2000. Reduce Microbial contamination with Good Agricultural Practices.

Harris, L.J., D. Zagory, and J. R. Gorny. 2002. Safety factors. p. 301-314, in: A.A. Kader (ed). Postharvest Technology of Horticultural Crops, third edition. University of California, ANR Publ. No. 3311.



## Sanitizing Field Containers, Tools and Packhouse Surfaces

High pressure wash, rinse and sanitize all crop containers, tools and packhouse surfaces prior to each day's harvest. Sanitizers should be used only after thorough cleaning with abrasion to remove organic materials such as dirt or plant materials. Most commercial sanitizers contain chlorine or quaternary ammonium compounds (QUATS, QAC, benalkonium chloride, N-alkyl dimethylbenzyl ammonium chloride). Chlorine solutions prepared from chlorine gas, hypochlorites and chloramines are **not compatible** with quaternary ammonium compound sanitizers.

Selection of the sanitizer to use depends upon the surface to be cleaned, hardness of the water, application equipment available, effectiveness under ambient conditions and cost. All require extreme care when handled as either compressed gas, powders or concentrated liquids. Use the following table to assist in the selection of appropriate sanitizers for your operation.

|                             | Chlorine gas   | Hypochlorites<br>(Na, K or Ca<br>hypochlorite)                      | Chloramines<br>(di- or tri-chloro-<br>isocyanuarate)      | Quaternary<br>ammonium<br>compounds                |
|-----------------------------|--|---|---|--|
| <b>Used for:</b>            | All food contact surfaces  | All food contact surfaces   | All food contact surfaces                                 | Non-food contact, porous materials, drains, walls. |
| Sanitizer properties        |  |   |   |  |
| Concentration               | 25 to 200 ppm  | 25 to 200 ppm   | 25 to 200 ppm   | 200 ppm  |
| Germicidal activity         | High   | High  | High  | Varies   |
| Specificity                 | General  | General   | General   | Good against molds                                 |
| Speed                       | Fastest  | Fastest   | Fast  | Moderate   |
| Form                        | Compressed gas   | Powder better than liquid   | Powder  | Concentrated solution                              |
| Stability                   | Good   | Good  | Good  | Excellent  |
| Toxicity                    | Low  | Low   | Low   | None   |
| pH range                    | Best at 6-7.5  | Best at 6-7.5   | Best at 6-7.5   | Effective over broad range                         |
| Temperature                 | Maximum 115 °F (46 °C)   | Maximum 115 °F (46 °C)  | Maximum 115 °F (46 °C)                                    | Maximum 120 °F (49 °C)                             |
| Effectiveness in hard water | Activity decreases in very hard water (>500 ppm)                     | Activity decreases in very hard water (>500 ppm)                    | Activity decreases in very hard water (>500 ppm)          | Inactivated in hard water                          |
| Corrosion                   | Slight to moderate<br>Very corrosive at pH <6 or over 115 °F (46 °C) | Slight to moderate<br>Very corrosive at pH <6 or over 115°F (46 °C) | Low<br><br>Very corrosive at pH <6 or over 115 °F (46 °C) | None   |

Source: Price, R.J. 1992. Sanitizers for food plants. University of California Cooperative Extension Sea Grant Extension Program Publication p. 92-99.

## Traceback

The ability to identify the source of any fresh produce product is an essential part of good agricultural practices. This is especially important whenever several growers are contributing to a single load, or when produce is being exported by one grower from several different fields.

The following practices are advocated by the U.S. Food and Drug Administration.

- Develop procedures to track produce from the farm to the packer, distributor and retailer.
- Documentation should indicate the source of the product (farm identification and the field where it was produced), the date of harvest, and who handled the produce.
- Growers, packers and shippers should partner with transporters, distributors and retailers to develop management tools to facilitate the traceback process.

Example of a package label useful for traceback:

|                 |                    |
|-----------------|--------------------|
| Product         | Mango              |
| Variety         | Alphonso           |
| Farm name       | Pathak Brothers    |
| Location        | Kanpur, U.P. India |
| Field code      | 12                 |
| Date of harvest | 20 June            |
| Harvester code  | #4                 |
| Packer code     | #2                 |

Source: U.S. FDA. 1998. Guide to minimize microbial food safety hazards for fresh fruits and vegetables. Food Safety Initiative Staff (HFS-32). [www.fda.gov](http://www.fda.gov)

## For further information

To obtain more information about produce food safety programs contact the following organizations:

Cornell University  
Department of Horticulture  
134A Plant Science Building  
Ithaca, New York 14853-5904  
GAPs Program: (607) 255 1428;  
<http://gaps.cornell.edu/educational-materials>

Gateway to U.S. Government Food Safety Information: [www.foodsafety.gov](http://www.foodsafety.gov)

International Fresh-Cut Produce Association  
“Food Safety Guidelines for the Fresh-cut Produce Industry 3rd Edition”  
1600 Duke Street Suite 440  
Alexandria, VA 22314  
Phone (703) 299-6282; <http://www.creativew.com/sites/ifpa/about.html>

Produce Marketing Association  
P O Box 6036  
Newark, Delaware 19714  
Phone (302) 738 7100; FAX (302) 731 2409; [www.pma.com](http://www.pma.com)

United Fresh Fruit and Vegetable Association  
“Industrywide Guidance to Minimize Microbiological Food Safety Risks for Produce”  
727 N. Washington St.  
Alexandria, VA 22314  
Phone (703) 836-3410; [www.uffva.org](http://www.uffva.org)

University of California  
**Food Safe Program**  
One Shields Avenue, Davis, CA 95616  
Phone (530) 752-2647; [foodsafes.ucdavis.edu](http://foodsafes.ucdavis.edu)  
<http://foodsafes.ucdavis.edu/html/home.html>

U.S. Department of Health and Human Services, Food and Drug Administration ([www.fda.gov](http://www.fda.gov)). A guide to minimize microbial food safety hazards for fresh fruit and vegetables.  
<http://www.fda.gov/downloads/Food/GuidanceRegulation/UCM169112.pdf>

## **General References**

---

Aiyer, R.S. et al. 1978. No-cost method for preserving fresh cassava roots. *Cassava Newsletter* 4: 8-9. Cali, Colombia: CIAT.

ASEAN-PHTRC. 1984. Village Level Handling of Fruits and Vegetables: Traditional Practices and Technological Innovations. Postharvest Horticulture and Training Center, College of Agriculture, University of the Philippines at Los Baños. Extension Bulletin No. 1.

Bachmann, J. and R. Earles. 2000. Postharvest Handling of Fruits and Vegetables. ATTRA Horticulture Technical Note. p.19. ([www.attra.ncat.org](http://www.attra.ncat.org))

Brackett, R.E. 1999. Incidence, contributing factors, and control of bacterial pathogens in produce. *Postharvest Biol. Technol.* 15:305-311.

Broustead, P.J. and New, J.H. 1986. Packaging of fruit and vegetables: a study of models for the manufacture of corrugated fibreboard boxes in developing countries. London: TDRI. (for information contact NRI, Central Avenue, Chatham Maritime, Kent, ME4 4TB, United Kingdom).

Campbell-Platt, G. 1987. *Fermented Foods of the World: Dictionary and Guide*. Stonam, Massachusetts: Butterworth Heineman.

CIP. 1982. Annual Report. Lima, Peru: International Potato Center.

FAO. 1986. Improvement of Post-Harvest Fresh Fruits and Vegetables Handling. Regional Office for Asia and the Pacific. Maliwan Mansion, Phra Atit Road, Bangkok, 10200, Thailand.

FAO. 1989. Prevention of Post-Harvest Food Losses: Fruit, Vegetables and Root Crops. A Training Manual. Rome: UNFAO. p. 157.

Fellows, P. and Hampton, A. 1992. *Small-Scale Food Processing A Guide to Appropriate Equipment*. London: Intermediate Technology Publications. p. 158.

Grierson, W. 1987. Postharvest Handling Manual, Commercialization of Alternative Crops Project. Belize Agribusiness Company/USAID/Chemonics International Consulting Division, 2000 M Street, N.W., Suite 200, Washington, D.C. 20036.

Hagen, J.W. et al. 1999. California's Produce Trucking Industry: Characteristics and Important Issues. California Agricultural Technology Institute's Center for Agricultural Business, California State University, Fresno, California

- Hardenburg, R.E. et al. 1986. The Commercial Storage of Fruits, Vegetables, and Florist and Nursery Stocks. USDA Agriculture Handbook 66. p. 130.
- Harvey, E. et al. 1990. Harvesting and postharvest handling of papayas in the Caribbean. Bridgetown, Barbados: Inter-American Institute for Cooperation on Agriculture (IICA).
- Hunsigi, G. 1989. Agricultural Fibres for Paper Pulp. *Outlook on Agriculture* 18 (3): 96-103.
- Kader, A.A. (ed). 2002. *Postharvest Technology of Horticultural Crops* (3rd Edition). UC Publication 3311. University of California, Division of Agriculture and Natural Resources, Oakland, California 94608. p. 535.
- Kitinoja, L. 2013. Returnable Plastic Crate (RPC) systems can reduce postharvest losses and improve earnings for fresh produce operations. White Paper No. 13-01. The Postharvest Education Foundation. La Pine, Oregon USA. p. 26.
- Kitinoja, L. 2011. Developing and Promoting Sustainable Postharvest Technologies for India and Africa. UN CAPSA Palawija Newsletter Vol 28. No. 3, Dec 2011. p. 1-5 <http://www.uncapsa.org/Palawija/pn1112.pdf>
- Kitinoja, L and Thompson J F, 2010. Pre-cooling systems for small-scale producers. *Stewart Postharvest Review* 2010, 6(2):1-14
- Kitinoja, L. 1999. Costs and Benefits of Fresh Handling Practices Perishables Handling Quarterly, Special Issue: Costs and Benefits of Postharvest Technologies, No. 97: 7-13
- Kitinoja, L. and AlHassan, H. A. 2012. Identification of Appropriate Postharvest Technologies for Improving Market Access and Incomes for Small Horticultural Farmers in Sub-Saharan Africa and South Asia. Part 1: Postharvest Losses and Quality Assessments. *Acta Hort (IHC 2010)* 934: 31-40.
- Kitinoja, L. and Gorny, J.R. 1999. Postharvest Technology for Small-Scale Produce Marketers: Economic Opportunities, Quality and Food Safety. UC PTRIC Horticultural Series No. 21.
- Kitinoja L, Saran S., Roy S.K. and A.A. Kader. 2011. Postharvest Technology for Developing Countries: Challenges and Opportunities in Research, Outreach and Advocacy. *J of the Science of Food and Agriculture* 2011; 91: 597–603.
- Kupferman, E.M. 1990. Life after Benlate: an update on the alternatives. *Washington State University Tree Fruit Postharvest Journal* 1(1): 13-15.

Lipinski, B., Hanson, C., Lomax, J., Kitinoja, L., Waite R. and T. Searchinger. 2013. Creating a sustainable food future- reducing food loss and waste. World Resources Institute (WRI) working paper. [http://pdf.wri.org/reducing\\_food\\_loss\\_and\\_waste.pdf](http://pdf.wri.org/reducing_food_loss_and_waste.pdf)

Liu, F.W. 1988. Developing practical methods and facilities for handling fruits in order to maintain quality and reduce losses. Postharvest Handling of Tropical and Subtropical Fruit Crops, Food and Fertilizer Technical Center for the Asian and Pacific Region, Taipei 10616, Taiwan.

Lurie, S. 1998. Postharvest heat treatments of horticultural crops. Hort. Rev. 22:91-121.

Mitchell, F.G., Guillon, R. and R.A. Parsons. 1972. Commercial Cooling of Fruits and Vegetables. U.C. Extension Manual 43, University of California, Division of Agricultural Sciences, Oakland, California 94608.

Moline, H.E. 1984. Postharvest Pathology of Fruits and Vegetables: Postharvest Losses in Perishable Crops. U.C. Bulletin 1914, University of California, Division of Agriculture and Natural Resources, Oakland, California 94608.

NRC. 1992. Neem: A Tree for Solving Global Problems. Washington, D.C.: Bostid Publishing Co. p. 141.

Natural Resources Institute. 1994. Manual for Horticultural Export Quality Assurance. Chatham, UK: Natural Resources Institute. ([www.nri.org](http://www.nri.org))

Pantastico, Er. B. 1980. FAO/UNEP Expert Consultation on Reduction of Food Losses in Perishable Products of Plant Origin. (6 May 1980, FAO,, Rome). p. 54.

Paull, R.E. and J.W. Armstrong (eds). 1994. Insect pests and fresh horticultural products: treatments and responses. CAB International, Wallingford, UK, p. 360.

Postharvest Innovations (2012) Plan Series Number 2. Sizing rings.

Proctor, F.J. 1985. Post-harvest handling of tropical fruit for export. The Courier 92: 83-86.

Rangarajan, A. et al. (n.d.). Food Safety Begins on the Farm. A Grower's Guide: Good Agricultural Practices for Fresh Fruits and Vegetables. Ithaca: Cornell University. p. 28.

Reyes, M. U. 1988. Design Concept and Operation of ASEAN Packinghouse Equipment for Fruits and Vegetables. Postharvest Training and Research Center, University of the Philippines at Los Baños, College of Agriculture, Laguna.

- Ritenour, M.A., Sargent S.A. and J.A. Bartz. 2014. Chlorine Use In Produce Packing Lines. UF/IFAS HS-761. <https://edis.ifas.ufl.edu/ch160>
- Saran, S., Roy, S. K. and L. Kitinoja. 2012. Appropriate Postharvest Technologies for Improving Market Access and Incomes for Small Horticultural Farmers in Sub-Saharan Africa and South Asia. Part 2: Field Trial Results and Identification of Research Needs for Selected Crops. *Acta Hort (IHC 2010)* 934: 41-52.
- Shewfelt, R.L. 1990. Quality of Fruits and Vegetables. A Scientific Status Summary by the Institute of Food Technologists' Expert Panel on Food Safety and Nutrition. Institute of Food Technologists, 221 North LaSalle Street, Chicago, Illinois 60601.
- Shewfelt, R.L. 1986. Postharvest treatment for extending shelf life of fruits and vegetables. *Food Technology* 40(5):7078, 89.
- Shewfelt R.L. and Prussia, S.E. (eds). 1993. *Postharvest Handling A Systems Approach*. San Diego: Academic Press, p. 358.
- Smilanick, J.L 1995. Status of postharvest fungicides and growth regulators. *Perishables Handling Special Issue No. 82*: 30-32.
- Smilanick, J.L and J. Usall, I. Rodie. 1995. Biological control of postharvest diseases of fresh fruit. *Perishables Handling Special Issue No. 82*: 19-20.
- Sommer, N.F., R.L. Fortlage and D.C. Edwards. 2002. Postharvest Diseases of Selected Commodities. In: Kader, AA (ed). *Postharvest Technology of Horticultural Crops (3rd Edition)*. UC Publication 3311. University of California, Division of Agriculture and Natural Resources p. 197-249.
- Talbot, M. T. and Fletcher, J.H. 1993. Design and Development of a Portable Forced-Air Cooler. *Proceedings of the Florida State Horticultural Society* 106:249-255.
- Thompson, A.K. 1996. *Postharvest Technology of Fruits and Vegetables*. Blackwell Science, Ltd., Oxford, UK. p. 410.
- Thompson, J.F. 1994. Ripening facilities. *Perishables Handling Newsletter*. University of California, Davis, Special Issue No. 80: 5-8.
- Thompson, J.F. et al. 1998. Commercial cooling of fruits, vegetables, and flowers. Publ. 21567, ANR, University of California, Oakland, CA. p. 61.
- Thompson, J.F. et al. 2000. Marine container transport of chilled perishable produce. Publ. 21595, ANR, University of California, Oakland, CA p. 32.
- Thompson, J.F. et al. 2001. Effect of cooling delays on fruit and vegetable quality. *Perishables Handling Quarterly Issue No. 105* : 2-5.

## General References

Umar, B. 1998. The use of solar cooling to minimize postharvest losses in the tropics. *Tropical Science* 38: 74-77.

Walker, D. J. 1992. *World Food Programme Food Storage Manual* Chatham, UK: Natural Resources Institute.

Wills, R., McGlasson, B., Graham, D. and D. Joyce. 1998. *Postharvest: An Introduction to the Physiology and Handling of Fruit, Vegetables, and Ornamentals*. CAB International, Wallingford, UK, p. 262.

Winrock International. 2009. *Empowering agriculture: Energy options for horticulture*. US Agency for International Development p. 79.

Zagory, D. 1999. Effects of post-processing handling and packaging on microbial populations. *Postharvest Biol. Technol.* 15:313-321.



## Appendix A

---

### Sources of Additional Information on the Internet

*Information is added regularly and websites can change without notice, but an internet search using key words will generally find the most updated pages.*

#### Postharvest Equipment and Supplies

<http://qasupplies.com>

QA Supplies Company offers a wealth of products for handling produce from the identifying maturity in the field to managing the ripening room at the retail level. A variety of postharvest quality assessment tool kits can be ordered online – to receive a 20% discount, enter the code “postharvest”.

<http://www.qasupplies.com/produce-toolkit.html>

<http://www.poscosecha.com> and <http://www.postharvest.biz> - International Directory of Postharvest Suppliers.

<http://www.postharvest.org>

Inexpensive postharvest tool kits for field work, demonstrations and extension programs.

#### Grades and Standards, Phyto-Sanitary Regulations

Agricultural Marketing Service (AMS) at the U.S. Department of Agriculture

The Agricultural Marketing Service programs employ specialists who provide standardization, grading and market news services for many commodities. They enforce such Federal laws as the Perishable Agricultural Commodities Act and the Federal Seed Act. AMS commodity programs also oversee marketing agreements and orders, administer research and promotion programs, and purchase commodities for Federal food programs.

<http://www.ams.usda.gov/AMSV1.0/>

<http://www.ams.usda.gov/AMSV1.0/nop> (National Organic Program standards)

<http://www.ams.usda.gov/AMSV1.0/fv> (Specialty Crops Programs)

<http://www.aphis.usda.gov/>

The mission of the Animal and Plant Health Inspection Service (APHIS) is to protect America's animal and plant resources by:

- Safeguarding resources from exotic invasive pests and diseases
- Monitoring and managing agricultural pests and diseases existing in the United States
- Resolving and managing trade issues related to animal or plant health
- Ensuring the humane care and treatment of animals.

## **Marketing of Agricultural Products**

<http://www.bluebookprco.com/>

The Produce Reporter Company Blue Book Services allow members to check out vital business information such as credit ratings of potential buyers.

[www.pma.com](http://www.pma.com)

The Produce Marketing Association, founded in 1949, is a not-for-profit global trade association serving over 2,400 members who market fresh fruits, vegetables, and related products worldwide. Its members are involved in the production, distribution, retail, and foodservice sectors of the industry.

## **Food Safety Information**

<http://www.foodsafety.gov> - U.S. government information on food safety.

<http://onfarmfoodsafety.org/> - USDA's food safety resources for small-scale producers

<http://www.ucfoodsafety.ucdavis.edu> – University of California's food safety information.

<http://ucanr.org/sites/> - University of California's Good Agricultural Practices.

<http://cps.ucdavis.edu/> - Center for Produce Safety, University of California at Davis.

<http://www.globalgap.org/> - GLOBALGAP is a private sector body that sets voluntary standards for the certification of agricultural products around the globe.

## **Postharvest Handling Practices**

<http://postharvest.ucdavis.edu> At this University of California, Davis (UC Davis) website you will find a wide range of fact sheets on individual fruits and vegetables, temperature recommendations for storage, links to suppliers of postharvest equipment, many reference articles on the postharvest handling of perishables, and postharvest books available for sale.

<http://www.postharvest.org> Website hosted by The Postharvest Education Foundation offering low cost e-learning programs, and providing mentoring at no charge to extension workers and postharvest professionals interested in developing further skills in postharvest technology, training and demonstrations of practices.

Access links for instructions on how to construct a charcoal evaporative cool room, a zero-energy cool chamber and other small-scale postharvest technologies. A CD Rom of a wide range of postharvest training materials is available free of charge by

email order (\$7.00 fee for copying services, packaging, postage, shipping and handling).

<http://www.ars.usda.gov/is/np/CommercialStorage/CommercialStorage.pdf>

USDA Agricultural Handbook 66: Commercial Storage of Fruits, Vegetables and Florist and Nursery Stocks.

<http://www.fao.org/inpho/>

This United Nations website includes a variety of FAO and other publications that users can browse on-line or download for their personal use. Publications focus on handling, packaging, storage, marketing or training and extension.

<http://www.bae.ncsu.edu/programs/extension/publicat/postharv/>

This website sponsored by North Carolina State University offers information on postharvest cooling and storage options for many commodities.

<http://postharvest.ifas.ufl.edu>

University of Florida Postharvest Group

<http://www.postharvest.tfrec.wsu.edu>

Washington State University postharvest information.

<http://www.postharvest.com.au/>

Sydney Postharvest Laboratory information (Australia).

<http://www.sardi.sa.gov.au/horticulture/>

South Australian Research and Development Institute.

<http://www.chainoflifefnetwork.org>

A comprehensive assembly of information about postharvest handling of floral crops.

<http://anrcatalog.ucdavis.edu>

This website describes the many publications, slide sets and videos on agriculture and horticulture developed and offered for sale by the University of California. There is also a long list of free publications available to read online or to download.