

# Signal Processing for the Electric Guitar

---

## Electric Guitar Distortion Pedal Design

A Major Qualifying Project work program plan to be submitted to the faculty of Worcester Polytechnic Institute's Department of Electrical and Computer Engineering in partial fulfillment of the requirements for the Degree of Bachelor of Science

9/2/08

Submitted by:

Nathaniel Osgood

June-chi Hong

Jacqui Richardson

\_\_\_\_\_  
\_\_\_\_\_  
\_\_\_\_\_

Submitted to:

Professor Labonté

\_\_\_\_\_

## Executive Summary

Heavy metal music is known to be loud, with heavily distorted guitars and squealing pinch harmonics, wailing tremolos, and fast guitar solos. These sounds are all brought to life by high gain amplification circuitry to convert the classical clean guitar signal away from the pristine and quiet to a sound much darker, full of an energy and passion unlike that of any other genre of music. Our goal for this project was to design a device that brings the ‘metal’ out of an electric guitar. There are many methods that guitar players and their sound technicians use to produce this sound; this project considers two of them: distortion and equalization.

Guitar signals are created by metal strings of specific tensions being picked causing them to oscillate, which induces an electric field in the inductive magnetic coils of the guitar, called pickups. The electric field induces a sinusoidal current in the coils of wire around the pickups, which travels through the coiled wire inside the pickups through a network of volume and tone potentiometers and out the output jack of the electric guitar. From there it is approximately between 140mV and 1.4V in amplitude, and changes frequency depending on fundamental frequencies of the notes played and their accompanying harmonics. This signal flows through a guitar cable to a series of signal processing circuitry and then is sent through the speakers of a guitar amplifier. This signal processing is often performed using devices called effects pedals, which are small metal boxes containing signal processing circuitry that interface with electric guitars and amplifiers in a series configuration called a pedal board. A pedal board sits on the floor, and consists of several pedals connected output of one to input of the next, until the last one, which is connected to the amplifier.

Distortion is created intentionally by driving amplifier circuitry to the supply rails, clipping the signal. More clipping is added to the circuit using diodes, to cut the amplitude to the

forward voltage drop across the diodes. This cuts the peaks and troughs off of the guitar signal, and this type of clipping is known as hard clipping, and is the principle cause of heavy metal type guitar distortion. Equalization is created by a series of band-pass filters attached to amplification which either boosts or attenuates certain key frequencies for electric guitar. Equalization allows for customization of guitar tone, to compensate for effects caused by other pedals and to help the guitarist set their sound to fit their individual style.

There are many effects pedals on the market today that include distortion circuitry and equalization circuitry in one pedal, but none of them are quite like ours. Many distortion pedals are designed for other styles of music than metal, and don't provide enough gain or the right style of clipping, and none have the ultimate level of equalization available in a pedal: ten band equalization. Most of them have a knob for the higher frequencies, the lower frequencies, and the middle frequencies and not much more. A ten band equalizer allows for adjustments of 10 different frequencies crucial to the electric guitar, for the most customization possible in a widely available pedal on the market today. Comparable distortion pedals alone to our distortion block retail between \$100-250, and they all fall short in terms of customizability, amount of distortion available, and undesired noise levels compared to our distortion stage. Ten band equalizer pedals retail between \$215-250 alone, and they do not contain distortion circuitry. Our pedal is designed to retail under \$200, and contains both a superior distortion circuit and the best equalization on the market, a combination of features that surpasses all existing competition, with a price far below that of the combination of competing products required to match the functionality of our design.

## **Abstract**

This project is an effects pedal for use with an electric guitar and amplifier. The project functions as both an analog distortion circuit with true hardware bypass, adjustable gain and filtering, and an active ten band equalizer. These functions can be cascaded or be used individually.

## Table of Contents

Executive Summary .....	ii
Abstract .....	iv
Table of Figures .....	v
List of Tables .....	vii
1. Introduction .....	1
2. Market Research .....	5
3. Product Requirements.....	16
4. Design Background and Experimentation.....	21
5. Final Product Design .....	33
6. Product Results .....	42
7. Cost Analysis.....	51
8. Failure and Hazard Analysis.....	54
9. Recommendations .....	57
10. Conclusion .....	61
11. Works Cited .....	63
A. Appendices .....	A-1
Appendix A: Research Schematics .....	A-1
Appendix B: Full Schematic .....	A-4
Appendix C: Full Parts List.....	A-5
Appendix D: PCB Design .....	A-8
Appendix E: Datasheets .....	A-9

## Table of Figures

Figure 1: Boss Metal Zone Pedal.....	5
Figure 2: Metal Muff Pedal.....	6
Figure 3: MXR Dime Distortion Pedal.....	6
Figure 4: Marshall Jackhammer Pedal.....	7
Figure 5: Krank Distortus Maximus .....	7
Figure 6: MXR 10-Band Equalizer.....	8

Figure 7: Artist's concept drawing of pedal board consisting of a distortion pedal in front of an equalizer pedal, this is the typical configuration for these two pedals in use.....	20
Figure 8: Boss Metal Zone pedal .....	21
Figure 9: Boss Metal Zone pedal built on a breadboard.....	22
Figure 10: The Insanity Box Pedal built on a breadboard .....	23
Figure 11: Operational amplifier gain and diode clipping stages of the Insanity Box .....	24
Figure 12: Asymmetrical Diode Clipping Signal and Circuit .....	25
Figure 13: Insanity Box CMOS Inverter Gain Stage.....	25
Figure 14: Before and after the second inverter.....	27
Figure 15: Insanity Box JFET gain stage.....	28
Figure 16: Ten band equalizer PCB and switch wiring diagram .....	30
Figure 17: Placement of the slide potentiometers for the ten band equalizer .....	30
Figure 18: The 3.3kHz range amplified by the ten band equalizer.....	31
Figure 19: System Block Diagram.....	33
Figure 20: LED logic schematic .....	37
Figure 21: Switch-wiring diagram .....	39
Figure 22: Input jack (right) and output jack (left) .....	40
Figure 23: Bottom view of the PCB with parts soldered on .....	42
Figure 24: Offset pins to correct potentiometer errors.....	43
Figure 25: Bottom view of the perf board with the equalizer slide potentiometers .....	44
Figure 26: Top view of the final PCB before switch wiring.....	45
Figure 27: Bottom view of the final PCB before switch wiring .....	45
Figure 28: Final pedal in case .....	48
Figure 29: Input and output jacks mounted to the box, the LED is green which indicates that the distortion block is switched on and the equalizer block is in bypass.....	49
Figure 30: LED indicator light is not lit even though the bypass switches have not been adjusted since the previous picture, because the input cable has been removed from the pedal removing power from the circuit.....	49
Figure 31: Standoffs and screws mounting the PCB to the bottom of the box.....	50
Figure 32: Inside the box .....	50
Figure 33: Return on Investment (ROI) Chart for our Product .....	52
Figure 34: Boss Metal Zone schematic - Part 1 .....	A-1
Figure 35: Boss Metal Zone schematic - Part 2.....	A-2
Figure 36: Boss Metal Zone schematic - Part 3.....	A-2
Figure 37: The Insanity Box diction circuitry, our settings for the trim potentiometers are shown in parenthesis .....	A-3
Figure 38: Ten-band graphic equalizer design.....	A-3
Figure 39: Final PCB design.....	A-8

## List of Tables

Table 1: Weights for each criteria.....	9
Table 2: Assigned weights for value analysis.....	9
Table 3: Competitor value analysis.....	11
Table 4: Customer Requirements and Product Specifications.....	19
Table 5: Frequency and capacitor value selections for the ten-band equalizer .....	36
Table 6: Truth table for the LED logic .....	37

# 1. Introduction

## 1.1 Problem Statement

Distortion in amplifiers is commonly considered a design flaw in most applications of circuit design. Amplifiers are commonly used to boost signals without distorting them, to preserve the original signal. This is definitely not the case when designing signal processing systems for the electric guitar. Distortion is an essential trait for most guitar amplification circuitry, especially for rock and heavy metal musicians. Musicians everywhere use many different types of distortion circuits to achieve the sound that they desire; for guitar players, this sound is referred to as their guitar tone. Every circuit in the signal path from the guitar itself to the amplifier and the amplifier speakers, and even the power source itself impacts the overall guitar tone. There is a vast industry dedicated to guitars, amplifiers, effects, and even the cables that connect them. ‘Effects’ is a term referring to any pedal or circuitry that is intentionally connected between the guitar and the amplifier, to affect guitar tone. Effects are often called ‘pedals’ or “effects pedals” because they are located on the floor in front of the guitar player or the guitarist’s tech, and buttons on them are stepped on to adjust them while the guitarist is playing. For the scope of this project, we are only considering distortion and equalization, out of the several different types of effects pedals that exist.

Distortion of a guitar signal is created by clipping. There are two basic types of distortion for guitar: soft clipping and hard clipping. Soft clipping is generally referred to by members of the music industry as ‘overdrive’, while hard clipping is commonly called ‘distortion’. This pedal is a heavy metal distortion effect, and heavy metal guitar sound is created by almost exclusively hard clipping circuitry for the crucial heavily distorted sound that defines the genre



of music. From this point on, the term ‘distortion’ will be used to refer to hard clipping, which in the most basic sense is clipping the peaks and troughs off of the sinusoidal signal that makes up any audio signal.

There are two fundamental methods of creating distortion for electric guitar signal processing: analog and digital. Analog distortion consists of entirely analog components, contains no CPU and does no sampling. It is considered by many in the music industry to be the preferred method of distortion. Digital distortion is created by sampling the analog guitar signal (as all real world audio signals are analog) to digitize it and allow a CPU to read the input, and transform it with programmed alterations, and then the signal is converted back to analog before the output jack of the pedal. Digital distortion circuitry is built to model the designers’ best approximations of the effects of analog circuitry on a guitar signal. Many musicians consider digital distortion circuitry to impart sterility to guitar tone, taking away from the rawness of analog sound. This distinction is a matter of opinion, but it is an opinion shared by many, including this group. The group lacked a background in digital signal processing, and would have been unable to translate the processing necessary into a program to be downloaded to a CPU without significant research, which there was insufficient time for.

### **Glossary of terms:**

**Bypass:** Pedals are designed to be connected in series on a pedal board, and they have two basic functions: on and bypass. Bypass refers to when the device is connected in the signal path between the guitar and amplifier, but not switched on.

**Headroom:** the difference between the positive and negative supply rails of an amplifier, more headroom means more gain before the signal is clipped from pushing the output of the amplifier to its supply rails

**High gain:** For most electrical engineering usages, the term ‘gain’ refers only to the transfer function of an amplifier. In the metal guitar signal processing industry, the term ‘gain’ refers to the amount of clipping a device can impose on a guitar signal, or how heavily distorted it can make the signal. Heavy metal distortion uses hard clipping to achieve the sound that defines the genre of music.

**Muddy:** a term referring to a flaw in guitar tone characterized by lack of clarity especially in the lower frequencies

**Pedal board:** A pedal board is several effects pedals connected together in series between the guitar and amplifier, the order of which will affect guitar tone. The order of devices is usually counted from the guitar to the amplifier, the device that is connected directly to the guitar is considered ‘first’ in the pedal board, the device connected to the amplifier is considered ‘last’. This distinction matters because parts of this paper refer to pedals connected ‘before’ or ‘after’ other pedals. Connecting something ‘before’ another pedal means connecting it closer to the guitar than the other pedal being referred to. Connecting a pedal ‘after’ another pedal means connecting it closer to the amplifier in the effects chain. An example of a pedal board with two pedals is shown in the artist concept drawing, which is Figure 7 in Section 3.2: Product Layout.

**Pinch harmonic:** an intentional high-pitched squeal created by dragging your thumb across the string immediately after the pick hits it, abundant in metal music, requires high gain to make them as noticeable as they are in metal

**Thin:** a flaw in guitar tone characterized by a sterile sound, or a lack of fullness to notes

## 2. Market Research

### 2.1 Competition Analysis

There are many distortion and equalizer pedals on the market today. Examples of similar pedals providing these functions include the: Boss Metal Zone, Electro Harmonix Metal Muff, MXR Dime Distortion, Marshall Jackhammer, Krank Distortus Maximus, and the MXR Ten Band Graphic EQ. The features of these pedals and their prices will be compared to analyze existing competition below. Parts of the analysis of competition in terms of effects on guitar tone are subjective, and as such reflect the opinions of the group. If schematics were not available to the group, the pedal could not be considered as a distortion block in our design.

Competitor 1: Boss Metal Zone

MSRP: \$160



Features: High gain. Three band graphic equalizer. Middle frequency selection. Powered by either a 9V battery or an AC adapter.

Cons: No true hardware bypass, which causes the effect to affect the guitar signal even when switched off. Much noise is present on the distortion when the pedal is switched on, especially when the guitar is not being played. The equalization circuitry is not as effective as was desired. Price.

Figure 1: Boss Metal Zone Pedal

Competitor 2: Electro Harmonix Metal Muff

MSRP: \$119



*Features:* High gain. Three band graphic equalizer. Top boost for amplifying high frequencies. True hardware bypass. Powered by either 9V battery or AC adapter.

*Cons:* Three band equalization. Unavailable schematics.

Figure 2: Metal Muff Pedal

Competitor 3: MXR Dime Distortion

MSRP: \$217



*Features:* High gain. Three band graphic equalizer. Eighteen Volt power supply for more amplifier headroom. Middle frequency scoop function

*Cons:* No true hardware bypass. Three band equalization. 18V supply requires two 9V batteries or an 18V AC adapter. Price. Unavailable schematics.

Figure 3: MXR Dime Distortion Pedal

Competitor 4: Marshall Jackhammer

MSRP: \$119



*Features:* High gain. Two distortion modes, Three band graphic equalizer. Middle frequency selection. True hardware bypass. Powered by a 9V battery or an AC adapter

*Cons:* Unavailable schematics. Three band equalizer

Figure 4: Marshall Jackhammer Pedal

Competitor 5: Krank Distortus Maximus

MSRP: \$225



*Features:* High gain. True hardware bypass. Three band equalizer

*Cons:* Three band equalizer. Price. Unavailable schematics.

Figure 5: Krank Distortus Maximus

## Competitor 6: MXR 10-Band Graphic Equalizer

MSRP: \$223



Figure 6: MXR 10-Band Equalizer

*Features:* 10-band graphic equalizer. Input and output gains. LED clipping indicator on input and output gain sliders. 18V power supply for more amplifier headroom, powered by AC adapter

*Cons:* No true hardware bypass. 18V power supply.

Unavailable schematics.

## 2.2 Value Analysis

Characteristics of competing products were evaluated based on six characteristics: high gain distortion, noise factor, power supply, equalization, bypass mode, and price. These characteristics were given a weight value between zero and three to scale each characteristic according to importance. Each competing pedal was given a score between zero and three to quantify the extent to which they met requirements for each characteristic. Weight and score values are clarified in the following tables.

Table 1: Weights for each criteria

		Score	Description
<b>Characteristic</b>	<b>Distortion</b>	3	High gain, full sounding, perfect for heavy metal guitar
		2	High gain but thin or muddy sounding, lacking in definition
		1	Moderately high gain but not quite enough, full sounding
		0	Not hard clipping, unusable for metal
	<b>Noise Factor</b>	3	Quiet when not playing and device is on
		2	Hum on high gain setting when not playing, no hiss or static and silent otherwise
		1	Hum, hiss, and static when not playing
		0	Hum, hiss, static or other noise which is very noticable at all times the device is on
	<b>Power Supply</b>	3	Device can be powered by either a single 9V battery or an AC adapter
		2	Device is powered by multiple 9V batteries or an AC adapter
		1	Device can only be powered by an AC adapter
		0	N/A
	<b>Equalization</b>	3	Ten band Equalizer with input and output level adjustments
		2	Less than ten band equalizer that works well, lots of customization available
		1	Less than ten band equalizer that is lacking in usable settings
		0	No equalizer included or equalizer has no useful settings
	<b>Bypass Mode</b>	3	True hardware bypass, a wire shorts input to output when device is off
		2	N/A
		1	N/A
		0	No true hardware bypass, device has buffered bypass and affects tone when off
<b>Price</b>	3	Very reasonably priced for the quality and features	
	2	Fairly priced for the quality and features	
	1	Overpriced for the quality and features	
	0	Unacceptably overpriced, inferior quality and features	







Table 2: Assigned weights for value analysis

Characteristic	Weight Assigned
High Gain Distortion	3
Noise Factor	2
Power Supply	1
Equalization	3
Bypass Mode	3
Price	2



Characteristics of the value analysis were prioritized with weights from one to three. A weight of one represents a desired trait, a weight of two represents an important trait, and a weight of three represents an essential trait. “High gain distortion” was given a weight of three because it is essential to a distortion pedal for heavy metal applications. “Noise factor” was given a weight of two, because it is something that was strongly considered in evaluating competition, but not essential because there are other products on the market to lessen noticeable noise. For the purposes of this project, “noise factor” refers to the audible hiss or static that the pedal creates when the device is turned on and the guitar is not being played. The “power supply” characteristic reflects the efficiency of competitive designs in terms of what power source they require to function. This was given a weight of one, because efficiency of the design in terms of power use is desired, but not crucial. The desired power source for the pedal is a single 9V battery, which is a very common power source for effects pedals. ‘Equalization’ was given a weight of three because it is crucial to the ability to customize the tone produced by the pedal. The ideal equalization out of effects pedals in production is a ten band equalizer with input and output levels, as it offers the most customization of sound per commercially available pedal. “Bypass mode” refers to the method of bypassing the pedal when it is switched off but remains in the signal path between the guitar and amplifier. This characteristic received a weight of three because true hardware bypass is crucial to maintain signal integrity when the device is switched off. Bypass mode is a binary category, either the evaluated device has true hardware bypass and receives a score of a three in that characteristic, or the device has buffered bypass, and receives a score of a zero in that characteristic. The ‘price’ of competing pedals was given a weight of two, because it is important to consider the cost of competition pedals to effectively evaluate them, but cost is not an essential design consideration.

Table 3: Competitor value analysis

Product			Characteristics							Total Score
Image	Brand	Model	High Gain Distortion	Noise Factor	Power Supply	Equalization	Bypass Mode	Price		
	Boss	Metal Zone	2	1	3	1	0	1	16	
	Electro Harmonix	Metal Muff	3	2	3	2	3	2	37	
	MXR	Dime Distortion	2	2	2	2	0	0	18	
	Marshall	Jackhammer	3	1	3	2	3	2	33	
	Krank	Distortus Maximus	3	2	3	2	3	0	31	
	MXR	10-Band Equalizer	0	3	3	3	0	1	20	
	Our Pedal	Expectations	3	3	3	3	3	3	42	

Boss Metal Zone

The Boss Metal Zone received an overall score of 16 on the weighted value analysis scale. It received a two for “high gain distortion” because it does have adequate distortion, but the tone of the pedal is rather thin sounding, and lacks in overall definition of sound. The pedal adds a very noticeable hiss, static, and hum when in bypass mode when the guitar is not being

played, so the Metal Zone received a one in the “noise factor” category. It can be powered by either a 9V battery or an AC adapter, so it received a three in the “power supply” score. The equalization of the Metal Zone is quite generic, even with spending significant time adjusting the settings, the group was unable to attain an acceptable sound. The best the Metal Zone offered was a thin high frequencies and muddy low frequencies, which was not pleasing to ears of the group. The Metal Zone received a score of a one in the ‘equalization’ category. This device has buffered bypass, which affects guitar tone when the device is off and resulted in a score of zero in the “bypass mode” category. The Metal Zone received a score of one in the ‘price’ category because a suggested retail of \$160 is overpriced for a China-built pedal with the features provided.

*Note on the Boss Metal Zone: The Metal Zone was built on a breadboard and considered using it in our design prior to discovering all of its flaws, as it is a widely used heavy metal distortion pedal. The flaws in the Metal Zone will be covered in more detail later, in Section 4.1.*

### Electro Harmonix Metal Muff

The Electro Harmonix Metal Muff received an overall score of 37. This is the highest scoring pedal out of the competing pedals researched by the group. This pedal meets or exceeds requirements for design characteristics in all except “noise factor,” and ‘equalization.’ The Metal Muff scores a three on “high gain distortion” because it provides an abundance of gain perfect for heavy metal, while still maintaining a fullness of sound and not becoming muddy in the low end or thin in the high end. In addition the Metal Muff offers a switchable amplification of a narrow band of higher frequencies, which is a functionality commonly used by lead guitarists playing live metal concerts to add loudness to guitar solos so that they can clearly be heard by

the audience over the rest of the band. The Metal Muff received a two in the “noise factor” characteristic due to the hum added to the guitar tone at high gain settings. This hum is acceptable because it does not contain any hiss or static and is generally considered normal under high amounts of gain. The Metal Muff can be powered by either a 9V battery or an AC adapter, so it received a three in the “power supply” score. The equalization of the Metal Muff is very effective as a three band equalizer, but it lacks the level of customization of a ten band equalizer, so it scores a two in the ‘equalization’ category. This device has true hardware bypass, so it received a score of a three in the “bypass mode” characteristic. The Metal Muff is reasonably priced at a suggested retail of \$119 for a full featured, well designed pedal manufactured in the United States, so it earned a three in that category.

### MXR Dime Distortion

The MXR Dime Distortion received total score of 18. High gain distortion is attainable with this pedal, but it offers little in terms of customization of sound. It is essentially only one amount of distortion, the gain knob does not affect the sound much unlike most pedals, so it received a two in the “high gain distortion” characteristic. The Dime Distortion received a two in the “noise factor” because it does produce a hum when switched on and the guitar is silent, but no hiss or static. This device is powered by 18V DC, and requires two 9V batteries or an AC adapter, so it receives a two in the “power supply” category because it requires twice as many batteries as a standard pedal. The equalization of this pedal is a three band equalizer, which resulted in a score of two in the ‘equalization’ section. The Dime Distortion scores a zero in “bypass mode” because it is not true hardware bypass. It also scored a zero in ‘price’ with a

staggering MSRP of \$217, as it is an attempt at marketing the sound of a famous guitar player in a box, and is priced as such.

### Marshall Jackhammer

The Jackhammer distortion pedal by Marshall scored a 35 on the value analysis chart, with a three in the “high gain distortion” category because it produces a very heavy sounding distortion that is full of character. It received a “noise factor” score of one because it creates a static and hiss at high levels of gain, along with a hum on the signal. The Jackhammer is powered by either a 9V battery or an AC adapter, so it receives a score of three in the “power supply” criterion. The three band equalizer in the Jackhammer is effective but not the ideal 10-band equalizer, so the pedal receives a two in the category of ‘equalization’. This product has true hardware bypass, earning a three in the “bypass mode” category. The Jackhammer is reasonably priced at a MSRP of \$119 for its features, and earned a three in the ‘price’ category.

### Krank Distortus Maximus

The Krank Distortus Maximus received an overall score of 33, with a three on “high gain distortion” because it provides a well-balanced heavy distortion. The Distortus Maximus produces a hum at high gain levels, but no hiss or buzz, so it received a two in “noise factor”. It can be powered by either a single 9V battery or an AC adapter so it received a three in “power supply”. The Krank has a three band equalizer that functions well so it receives a two in ‘equalization’. This product uses true hardware bypass, and earned a three in “bypass mode”. The Krank received a one for ‘price’, and with a MSRP of \$225 it is the most expensive distortion pedal examined by this value analysis.

### MXR 10-Band Equalizer

The MXR 10-Band Equalizer received an overall score of 18. This product is not a distortion pedal, and provides no intentional high gain distortion via hard clipping unlike the other pedals, so it received a zero in that category. The equalizer creates no hiss or static when switched on, so it received a three in the “noise factor” category. It can only be powered by an 18V adapter, which earned it a one in the “power supply” category. This device contains a 10-band equalizer with input and output amplification, complete with LED clipping indicators that flash on the input and output gain sliders if clipping occurs at either the input or output amplifier. These features earned the MXR 10-Band Equalizer a three in the ‘equalization’ category. The MXR equalizer contains no true hardware bypass, which resulted in a zero in “bypass mode”. With a MSRP of \$223 it is the second highest priced pedal reviewed by this value analysis, and it received a one in the ‘price’ category.

### Expectations for Our Pedal

Our pedal design ideally should include the best facets of each value analysis criterion, earning it a three in every category. It should have a perfect high gain distortion that is not thin or muddy. It should not create noise when the device is switched on and the guitar is not being played. It should be able to be powered by a single 9V battery, as other industry standard pedals are. Our design should include a ten band equalizer. The pedal designed by the group must have true hardware bypass, and be priced competitively to enter the market. A pedal containing all of these features would earn a score of 42 on the value analysis chart.

### **3. Product Requirements**

#### **3.1 Customer Requirements**

The product should be safe, free of static hazards. It must be able to be interfaced with an electric guitar and an amplifier, and should be mechanically stable enough to support plugging and unplugging guitar cables, and be able to be turned on and off via stomp switches. All knobs, buttons, and externally adjustable parts should be located in logical positions and should be easy to adjust. The purpose of this device is to serve as a distortion pedal and an equalizer pedal in one enclosure, without losing any functionality that the two separate pedals would have. The distortion pedal itself must provide enough gain to be used for a heavy metal guitar sound. Analog distortion should be used. There should be a visible indicator that displays when the device is on. The device must have true bypass to prevent signal loss when it is off. Unplugging the input cable should remove power from the pedal to extend battery life. Price should be comparable to a combination of the prices of analog distortion pedals and equalizer pedals of similar style.

#### **3.2 Product Specifications**

The customer will expect the device will be safe and durable. The box itself should be grounded to avoid static hazards. The box edges will also be rounded to avoid sharp edges that could possibly be harmful to the user. Most pedals are made from aluminum that is strong enough to handle being repetitively stomped on, and light enough to still be portable. It should be durable enough to support the input and output cables and stomp switches. These devices will be mounted to the sides and top of the box in order to place most of the mechanical stress on the box itself. The stomp switches themselves are also mechanically stable to handle the stress of being stepped on.

The device should interface with an electric guitar on the input side and an amplifier on the output side. The signal amplitude out of an electric guitar generally varies between 100mV and 1V RMS, or approximately between 140mV and 1.4V peak. The output signal of an effects pedal to the amplifier is generally between 0V and 9V. Electric guitars and amplifiers both have impedances greater than 1M $\Omega$ . These high impedances at the inputs and outputs need to be taken into consideration and be matched at both the inputs and outputs of our design.

There must be sufficient gain available for the device to be qualified as being heavy metal distortion pedal. Since the device is analog it will consist only of analog components (resistors, capacitors, operational amplifiers, etc.). The signal from an electric guitar pedal usually ranges between 0 to 9V and rides on a 4.5V offset. If the guitar signal is applied to an amplifier and the signal is amplified beyond the rail voltage then the waveform will be clipped at the 0 and 9V rails. If a 140mV signal riding on a 4.5V offset passes through an amplifier with a gain of 65, the signal will just start to clip to the voltage rails. Heavy metal requires more gain with the least amount of undesired noise. So the gain of the distortion block must be greater than 65, and low-noise amplifiers will be used.

The device should be user-friendly with knobs placed in a logical configuration. Any stomp switches should be located on the bottom of the box facing the user. At the top of the box there are adjustable gain, volume, and tone knobs. In the center of the device there is an LED to indicate when the device is in use. A tri-colored LED will serve the purpose since the pedal has two functions.

The pedal should be multi-functional. The pedal will have a distortion function and a ten-band equalizer function in one. It should be optional whether these functions are being used separately or at the same time. This will be accomplished using two switches, one for the



equalizer circuitry and one for the distortion circuitry. When the device is off there should be no signal losses beyond the transmission line losses of the cables and bypass wires. This will be accomplished by using true bypass. True bypass is essentially a wire that bypasses the circuitry. When the distortion is on and the equalizer is off, the equalizer circuit will be bypassed. When the equalizer is on and the distortion is off, the distortion circuit will be bypassed. When both functions are off, both circuits will be bypassed with a wire. This bypass circuitry will be incorporated into the setup of the two switches.

The pedal should also have a long battery life. Generally pedals are powered by a 9V battery. When the pedal is off it should not drain the battery. To extend battery life a three-terminal stereo input jack will be used to remove the battery from the circuit when the pedal is unplugged.

The device should be competitively priced to succeed in the current market. It should be of equal price or cheaper than the combined prices of a ten-band equalizer pedal and a distortion pedal. Prices of comparable distortion pedals range between \$100 and \$250. Prices of equalizer pedals alone range between \$200-\$250. Our goal is to produce a pedal to be sold at \$350 or less since the pedal combines the two functions. A full list of the customer requirements and the corresponding product specifications are shown in Table 4.

Table 4: Customer Requirements and Product Specifications

Customer Requirement	Product Specification
Safe, free of static hazard	Box grounded, no sharp edges
Durable	Heavy duty stomp switches Strong aluminum casing
Able to be interfaced with an electric guitar and amplifier	<u>Guitar signal amplitude</u> : 100mV – 1V RMS, or 140mV-1.4V peak <u>Guitar impedance</u> : 100MΩ max <u>Output signal amplitude</u> : Between 0-9V <u>Amplifier impedance</u> : 100MΩ max
Sufficient distortion for heavy metal	Low noise operational amplifiers <u>Overall gain</u> : > 65 <u>Voltage clipping rails</u> : 0-9V, 4.5V offset
Logical configuration	Top: gain, tone and volume knobs Middle: tri-colored LED indicator Bottom: Stomp switches Left: Output Right: Input
Multi-functional	Distortion/Equalization 2 switches
Minimal signal loss when the device is off	True bypass: wire between input and output
Extended battery life	Three-terminal stereo input jack
Fairly priced	< \$350
Analog	Analog components (resistors, capacitors, operational amplifiers, transistors)

### 3.3 Product Layout

The enclosures of pedals are commonly made from aluminum. Almost all pedals have an input jack on the right side and an output jack on the left side. This configuration can vary when both input and output jacks are on the same side of the pedal as shown on the equalizer pedal in Figure 7. The guitar plugs into the input jack and the signal is distorted through the pedal circuitry. The output signal through the output jack is then passed to the guitar amplifier. Many guitarists cascade pedals in a configuration known as a pedal board. Figure 7 shows a distortion pedal with a ten-band equalizer pedal connected after it on a pedal board. The output of the last

pedal on a pedal board goes to the input of an amplifier. Pedals are usually powered by 9V batteries or have the option to plug into a wall outlet.

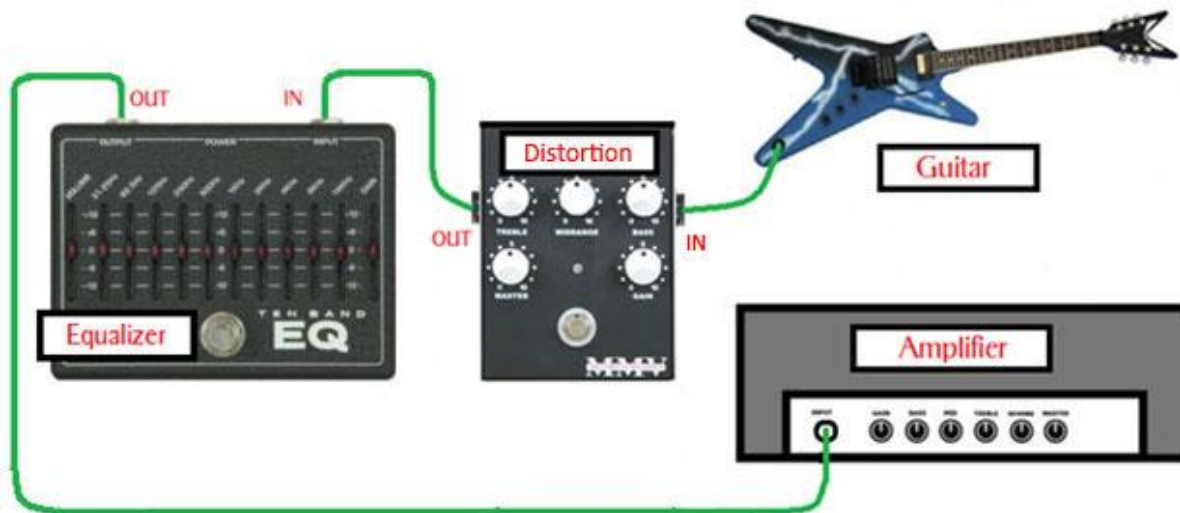

Figure 7: Artist's concept drawing of pedal board consisting of a distortion pedal in front of an equalizer pedal, this is the typical configuration for these two pedals in use.

On most pedals there are knobs at the top for gain, tone, volume, and equalization. Equalization adjusts the bass, middle, and treble frequencies. There is a stomp switch on the top that turns the pedal on and off when the user steps on it. When the pedal is off, it is bypassed so that the signal flows through it and to the other pedals in the pedal board and to the amplifier. There are two bypass methods, either buffered bypass or true bypass, two terms which were described in section 1.1. True bypass will be used to fulfill product requirements such that that the signal at the input jack of the pedal is shorted directly to the output jack of the pedal 'bypassing' the effects pedal circuitry when the pedal is off.

## 4. Design Background and Experimentation

### 4.1 Building of the Boss Metal Zone Pedal

The initial design background was inspired by current effects pedals on the market. In our market research many different effects pedals that provide distortion and equalization were examined. The group expected to gain some practical design experience by building one of the well-known and respected pedals on the market called the Boss Metal Zone pedal.

The Boss Metal Zone is a distortion pedal that gives users an adjustable range of sounds. The circuitry is an analog pedal composed of analog components. It has gain and volume adjustment as well as a parametric, three-band equalizer. The complete schematic for the pedal is shown in Appendix A.



Figure 8: Boss Metal Zone pedal

The Boss Metal Zone pedal built on a breadboard is shown in Figure 9. An input jack and output jack were connected to the input and output of the pedal circuitry so that a signal from an electric guitar could be passed into the pedal and its output could be sent to a guitar amplifier.

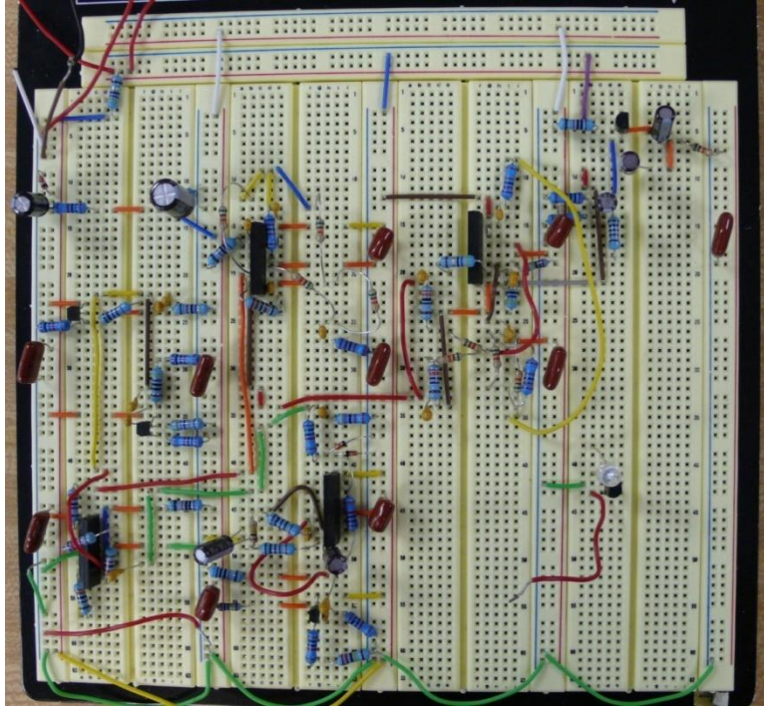

Figure 9: Boss Metal Zone pedal built on a breadboard

The pedal built on a breadboard added undesired noise to the signal. This excessive noise could be seen in the frequency domain and heard when the output signal was being amplified. Some noise was expected since the board has its own capacitance, but not noise of that magnitude. In an attempt to reduce noise, filter capacitors were added near the DC power sources and all of the wires were shortened. These attempts failed to lessen the noise to an acceptable level.

The group examined the output signal at each node with the oscilloscope to observe how each block affected the signal passing through. Most of the unwanted noise stemmed from the equalizer section. The equalization of the pedal did not function properly. Both the bass and the treble ranges existed in parallel to each other in the same feedback loop of an amplifier. The two ranges, when adjusted by the knob potentiometers, affected the sound of one another in an undesired way. Also, the parametric equalizer seemed to be an unnecessary feature that just allowed one Q value in the middle frequency range to be amplified. It made more sense to have multiple Q values in that one frequency range to be amplified, so other options such as the ten-band equalizer described in Section 4.3 were considered.

The Boss Metal Zone pedal, being a commercial design, exhibits typical functional blocks that many pedal designs on the market share. This is actually a con in the design because these stages have come to be generic features that all pedals have. Thus sound samples of pedal outputs were reviewed for the next design, so a pedal with much better performance and more uniqueness could be built.

## 4.2 Building of the Insanity Box

The next distortion circuit examined by the group was the Insanity Box. The schematic for this pedal is shown in Appendix A. Right away we were attracted to the simplicity of design of this circuit versus that of the Metal Zone. This circuit consists of three stacked gain stages, and not only sounded much clearer, but provided more distortion and far more customization than the Boss Metal Zone Pedal, and was much cheaper to implement. The entire Insanity Box built on a breadboard and taking up less than half the space of the Metal Zone is shown in Figure 10. The schematic for the Insanity Box is shown in Appendix A.

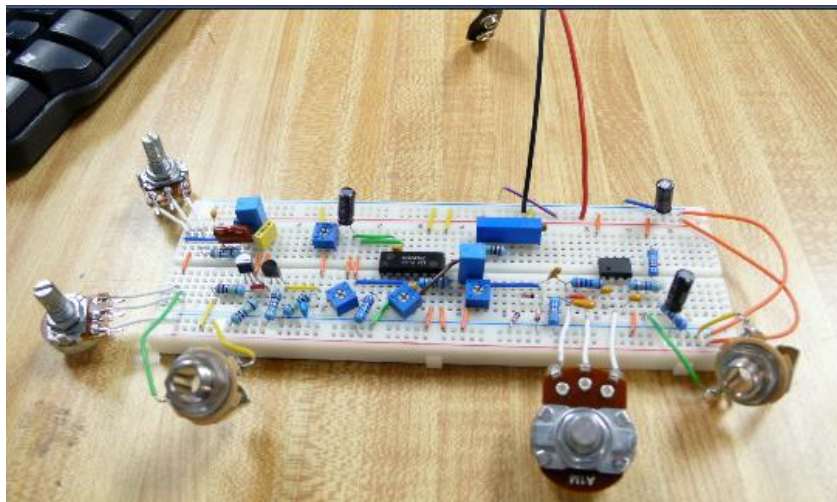

Figure 10: The Insanity Box Pedal built on a breadboard

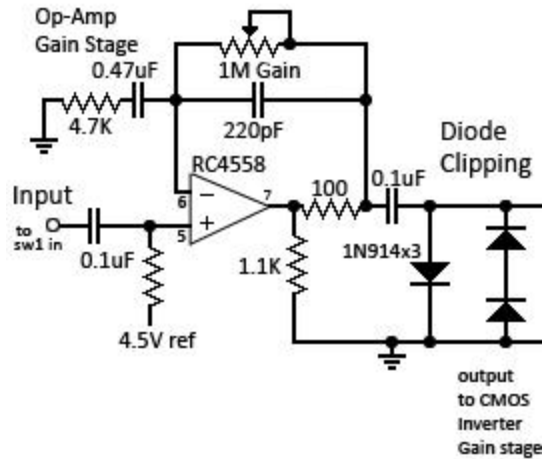

Figure 11: Operational amplifier gain and diode clipping stages of the Insanity Box

The pedal had some similar circuitry to the Metal Zone, such as an operational amplifier gain stage followed by diode clipping, which is common to many distortion circuit designs and is shown in Figure 11. However, the Insanity Box allowed for more gain adjustment at this stage with a  $1\text{M}\Omega$  potentiometer in the feedback loop instead of the  $250\text{k}\Omega$  potentiometer used in the Boss Pedal. The diode clipping following this stage was asymmetric clipping using three 1N914 diodes. An example of asymmetric diode clipping is shown in Figure 12. When the input signal is positive and approaches the forward voltage of the diode, the single diode on the left side is turned on, or forward biased, and the output voltage is limited to the forward voltage of the diode. When the signal is positive, the diode on the left is forward biased and the output voltage is limited to the forward voltage of the 1N914 diode, or  $0.7\text{V}$ . When the signal is negative, the two diodes on the right side are forward biased and the output voltage is limited to  $-0.7\text{V}$ - $0.7\text{V}$  or approximately  $-1.4\text{V}$  minimum below the bias level.

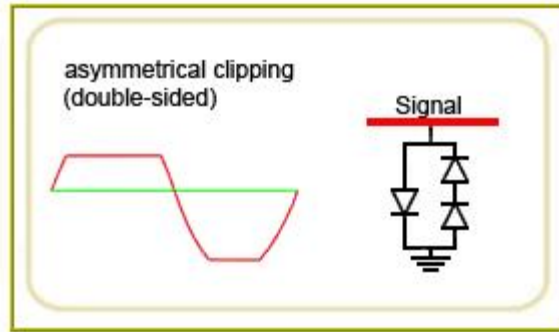

Figure 12: Asymmetrical Diode Clipping Signal and Circuit

Following the op-amp gain stage and asymmetrical diode clipping there is a CMOS inverter gain stage. The inverter gain circuit is shown in Figure 13. This consisted of two unbuffered CMOS inverters from the CD4049AE chip powered by the 9V rail of our circuit.

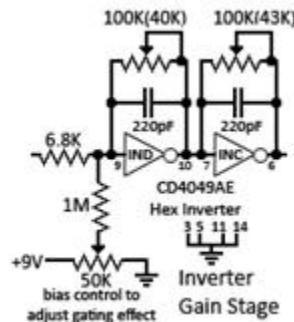

Figure 13: Insanity Box CMOS Inverter Gain Stage

The input of the CMOS gain stage connected via capacitive coupling to the diode clipping stage to isolate the CMOS gain stage from the DC bias of the previous stage. The CD4049AE is a hex inverter chip, and as such has four other inverters on the IC that are unused. These four unused inverter inputs are grounded to maintain stability of the two that are in use, to prevent the occasional pop or click that would be introduced to the guitar signal due to leakage inside the IC. As you can see below in Figure 14 the voltage corresponding to a logic high for the CD4049AE inverter is approximately 3.5V. There is a potentiometer that sets a bias of the input of the first inverter to stop an effect called gating, if the user wishes to do so. Gating is a term referring to blocking of a guitar signal once it falls below a certain amplitude threshold. This effect is caused by the operation of the inverters. Each inverter converts signals corresponding to



a logic low (0-3.5V) to a logic high (3.5V to the voltage supply rail, or 9V for a full battery), and a logic high to a logic low. When the CD4049AE converts a logic high to a logic low, it outputs the lowest end of the logic low range, or a value of between 0-0.05V.

The feedback resistors of each inverter are adjustable via trim pots. The first inverter is feedback potentiometer is set at 40k $\Omega$  and the second one is set at 43K $\Omega$ . The open loop gain of the CD4049AE is approximately 30. The resistor in the feedback loop biases the inverter into linear region operation, but causes the Miller Effect. The Miller Effect states that a Miller resistance can be seen at the input of the inverter, with a value of the feedback resistance divided by the open loop gain of the inverter. This means the Miller resistance reflected on the input of the first inverter is 40k $\Omega$ /30 or approximately 1.33k $\Omega$ . This resistance is in series with the 6.8k $\Omega$  resistor, for a total input resistance of 8.13k $\Omega$ . The gain of each inverter is calculated simply by dividing the feedback resistance by the input resistance and negating it, which is -40k $\Omega$ /8.13k $\Omega$ , or approximately negative five. There is no input resistor between the two inverter stages, so the input resistance is the miller resistance reflected to the input of the second inverter, which is 43k $\Omega$ /30 or approximately 1.43k $\Omega$ . The gain of the second inverter is -43k $\Omega$ /(1.43k $\Omega$ +6.8k $\Omega$ ), or approximately -5.2. The gain of the entire inverter stage is simply the gain of the first stage multiplied by the gain of the second stage, which yields a gain of approximately 26 for the CMOS inverter gain stage. The CD4049AE has a bandwidth of about 1.5 MHz when operating on a supply voltage of 9V, which is plenty for the purposes of this pedal.

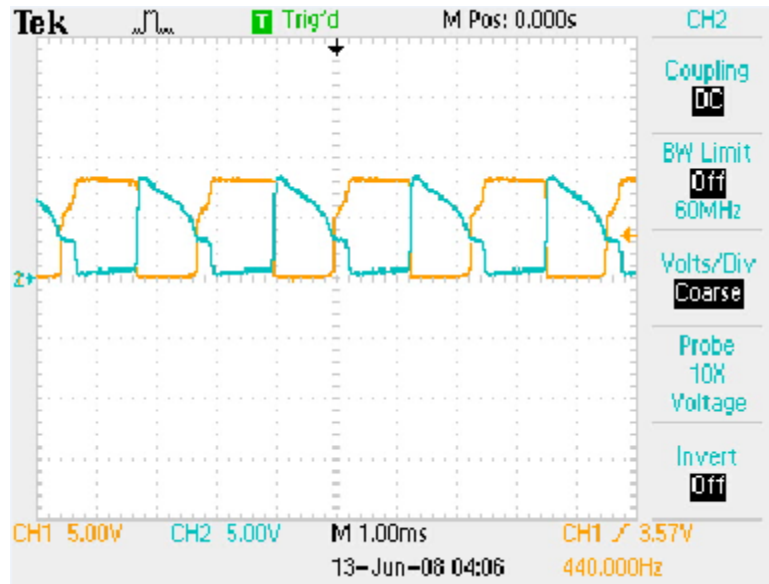

Figure 14: Before and after the second inverter

Each CMOS inverter in the CD4049AE package operated in the linear range can provide between 30 to 40dB of gain, or between 31.6 to 100 times and at 9V the bandwidth is about 1.5MHz. The addition of the resistor to the feedback loop limits current to the CMOS. As the resistance increases, the gain and bandwidth decrease. The user has the option to adjust the resistor to select the right tone for the sound they desire. The input and output impedance of the CMOS inverters are high, so following the CMOS stage is the JFET gain stage, shown in Figure 15 which has a very high impedance input.

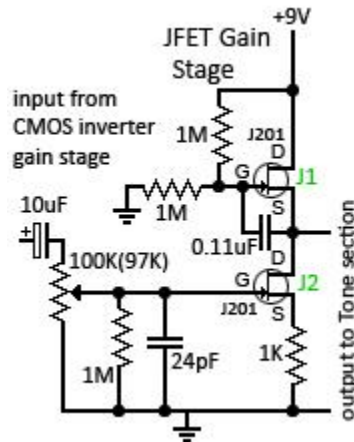

Figure 15: Insanity Box JFET gain stage

The 10 $\mu$ F polarized capacitor on the left in the transistor gain stage schematic blocks the DC offset of the signal. There is another trim potentiometer that adjusts the signal level before the gain stage. The 1M $\Omega$  resistor and the 24pF capacitor in parallel create a low-pass filter that blocks any frequency beyond 6.631kHz. The transistor gain stage consists of two J201 N-Channel JFETs. The voltage divider created by the two 1M $\Omega$  resistors sets a 4.5 reference voltage for the output signal. The drain current of J1 equals the drain current of J2. The equation for the drain current of a JFET operating in the active region is shown below, in Equation 1. Since the incoming guitar signal is being applied to the gate of J2 and the source of J2 is grounded, then the gate-source voltage is equal to the incoming signal  $V_{IN}$ .

$$I_{D2} = \beta (V_{GS2} - V_{TO})^2 = \beta (V_{IN2} - V_{TO})^2 \quad [\text{Equation 1}]$$

In Equation 1  $\beta$  is the transconductance coefficient and  $V_{TO}$  is the threshold voltage of the JFET device. The output voltage is then equal to the combination of the drain current and the 1K $\Omega$  resistor as described in Equation 2.

$$V_{OUT} - 0 = I_{D2} (1K\Omega) \quad [\text{Equation 2}]$$

Substituting Equation 1 into Equation 2 yields Equation 3, which is a direct relationship between the input and output signal. Equation 3 shows that the output signal increases exponentially as the input signal increases. Therefore, the gain ( $V_{OUT} / V_{IN}$ ) also increases exponentially with the input signal amplitude.

$$V_{OUT} = \beta (V_{IN} - V_{TO})^2 (1K\Omega) \quad \text{[Equation 3]}$$

The Insanity Box had many attractive features that will be added to the final design. Every gain stage of the Insanity Box was perfect for our desired sound. The adjustable trim potentiometers that can be adjusted with a screwdriver when the pedal case is open were also a bonus. The user can preset these values at each stage of the circuit to customize their sound to fit their own style.

### **4.3 Building of the Ten Band Equalizer**

Next, a ten band equalizer from [buildyourownclone.com](http://buildyourownclone.com) was built. The way a ten band equalizer works is that ten frequencies within the acoustic range of a guitar amplifier are chosen by the manufacturer when the equalizer is built. The user is able to adjust the levels of each of the ten frequencies using slide potentiometers. More on frequency selection as well as the circuitry and modifications are fully explained later on in Section 5.2.4 in the Functional Blocks section of the paper. The PCB used to build and test the equalizer was ordered directly from the website, and the switch and jack wiring diagram is shown in Figure 16.

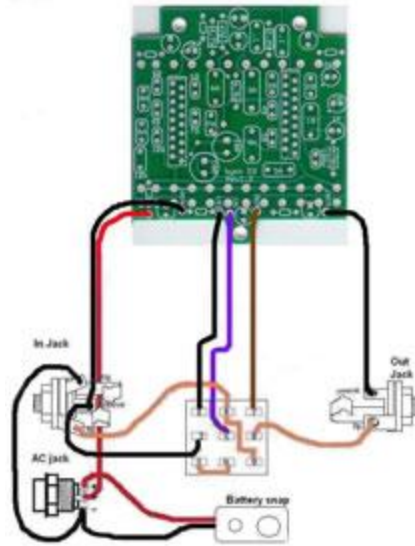

Figure 16: Ten band equalizer PCB and switch wiring diagram

Figure 16 is a bottom view of the PCB. The top view of the PCB is shown in Figure 17. Areas for where the slide potentiometers to adjust the ten frequency ranges are highlighted in red. Two of the slide potentiometers are for level (volume adjustment) at the input and output of the equalizer.

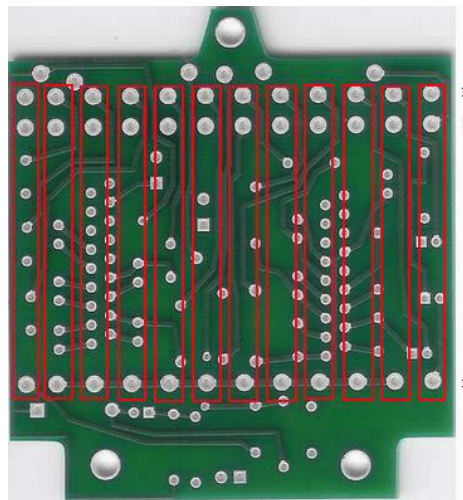

Figure 17: Placement of the slide potentiometers for the ten band equalizer

The equalizer was first tested separately from a distortion stage. To do this, wires were connected for the battery, ground, input, and output. The circuit was powered by a DC power supply set at 9V. For

the input signal a 140mV, 440 Hz signal was applied, which represents the fundamental frequency of an ‘A’ note from an electric guitar.

The signal was observed in the frequency domain. Then the slide potentiometers were adjusted to see what happened in the frequency domain. Figure 18 shows the result of all the potentiometers in the lowest position except for potentiometer designated for the 3.3kHz range. The frequency with the highest amplitude is 440Hz, in the picture below it appears at the very left side of the oscilloscope. The 3.3kHz equalizer band being all the way up, which is a gain of approximately five for that frequency. Notice that there is a spike in amplitude at this frequency that is roughly five times the amplitude of the noise. This boosted frequency also adds spikes at harmonics of 3.3kHz, with each successive harmonic having half the amplitude of the previous spike.

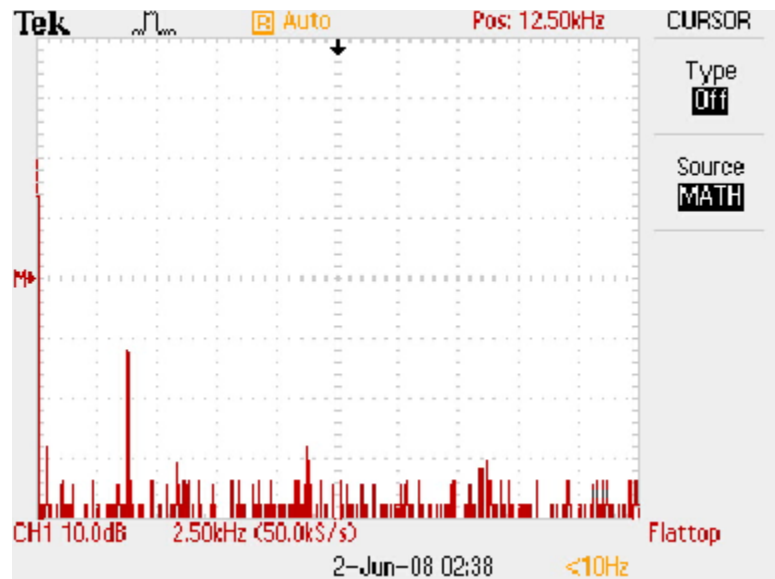

Figure 18: The 3.3kHz range amplified by the ten band equalizer

Similar tests were conducted on other frequency bands and the same results occurred. Multiple frequencies could also be adjusted at the same time.

The equalizer was connected to the output of the Insanity Box that was already built on the breadboard after tests confirmed that the equalizer functioned properly. The input jack was

connected to the beginning of the Insanity Box as it had been before. The equalizer was then powered by the 9V rail of the Insanity Box circuit and the output jack was connected to the output of the equalizer. A guitar signal was then applied and the equalizer functioned as expected. Adjustments made to the frequency bands of the signal via the potentiometers corresponded to a change in those frequencies of sound coming from the Insanity distortion circuit.

# 5. Final Product Design

## 5.1 System Architecture

The overall block diagram for our final design is shown in Figure 19. It consists of a power block, a distortion block, a ten-band equalizer, and an LED driver block. There is an option to bypass the distortion block, the equalizer block, or both. This is accomplished using switches. Switch wiring as well as each individual functional block is described in the following sections.

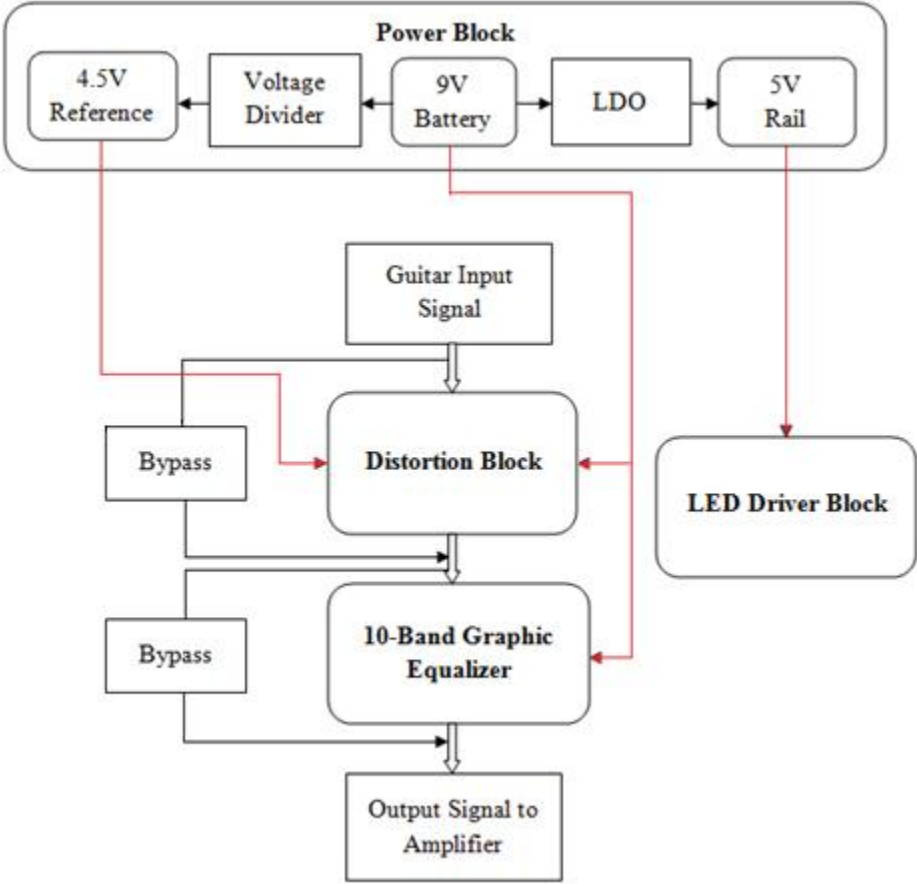

Figure 19: System Block Diagram



## **5.2 Module Descriptions**

A full schematic of our design is shown in Appendix B. It contains the modified Insanity Box schematic to include a ten-band equalizer and LED driver logic. The pedal serves two functions: it can be used as a distortion pedal, an equalizer pedal, or both. This is accomplished using bypass circuitry which is incorporated into two separated switches. Each functional block is described in detail in the following sections.

### **5.2.1 Input and Output Signals**

Each guitar note being played is between 140mV and 1.4V peak-to-peak. The output impedance of a guitar is around  $1M\Omega$  and must be matched at the input side of our device. The impedance of the amplifier is also approximately  $1M\Omega$ , the impedance of the amplifier must also be matched at the output of our design. The output signal that will be sent to the amplifier from our pedal will be between 0 and 9V peak-to-peak.

### **5.2.2 Power Block**

The power block of the pedal circuitry consists of a 9V battery and a simple voltage divider, consisting of two  $10k\Omega$  resistors to provide a 4.5V voltage reference to offset the signal midway between the 0 to 9V rails of the amplifiers in the distortion stage. Originally this was also designed to supply the 4.5V for the AND gates and inverter chips and power the LED in the LED Driver Block, however, after discovering that a simple voltage divider could not be used to drive the load of the LED circuitry, a 5V linear drop out voltage regulator (or LDO) was used to power this block. The input voltage to the LDO was 9V from the battery and the LDO supplies a constant 5V at the output to the LED Driver Block.

### 5.2.3 Insanity Box Distortion Blocks

For the operational amplifier stage the RC4458 amplifier was used, which is designed specifically for low noise applications. A  $1\text{M}\Omega$  potentiometer was used in the feedback loop in the Insanity Box for higher gain. Operational amplifiers have very high input impedances, so having an amplifier immediately at the first gain stage accounts for the high output impedance of an electrical guitar. The operational amplifier gain stage was followed by asymmetric diode clipping and the inverter and the JFET gain stages from the Insanity Box, described in detail in Section 3.2, because the sound of the distortion of the pedal was perfect for our application and the adjustable trim potentiometers to vary the inverter gain and various levels were more settings that the user could adjust.

### 5.2.4 Ten-band equalizer

For the 10-band equalizer, the equalizer circuit purchased from [buildyourownclone.com](http://buildyourownclone.com), shown in Appendix A, was built. Two BA3812L 5-channel graphic equalizer chips were used, powered by the 9V rail. The audible range for the electric guitar amplifier is between 100Hz and 6.2kHz, so the equalizer frequencies were chosen to emphasize ten frequencies in this band. The following equation describes these frequencies.

$$Frequency = \frac{1}{2\pi\sqrt{1.2\text{K}\Omega \times 68\text{K}\Omega \times C1 \times C2}}$$

The  $1.2\text{K}\Omega$  and  $6.8\text{K}\Omega$  resistors are internal to the BA3812L chip. Pole frequency values chosen within this range were 100Hz, 330Hz, 410Hz, 620Hz, 820Hz, 1kHz, 2.2kHz, 3.3kHz, 4.1kHz, and 6.2kHz. Notice that the spread is logarithmic, not linear, since at higher frequencies the ear cannot differentiate between closer frequencies. Using the equation, the two capacitor

values were chosen for each frequency selection accordingly. The capacitor selections corresponding to each frequency are displayed in Table 5.

**Table 5: Frequency and capacitor value selections for the ten-band equalizer**

<b>Frequency</b>	<b>C1</b>	<b>C2</b>
100Hz	1 $\mu$ F	.027 $\mu$ F
330Hz	.33 $\mu$ F	.0082 $\mu$ F
410Hz	.27 $\mu$ F	.0068 $\mu$ F
620Hz	.18 $\mu$ F	.0047 $\mu$ F
820Hz	.15 $\mu$ F	.0033 $\mu$ F
1kHz	.1 $\mu$ F	.0027 $\mu$ F
2.2kHz	.068 $\mu$ F	.001 $\mu$ F
3.3kHz	.033 $\mu$ F	820pF
4.1kHz	.027 $\mu$ F	680pF
6.2kHz	.018 $\mu$ F	470pF

The gain at each pole frequency is then controlled by each of the ten 100K $\Omega$  slide potentiometers. Each potentiometer is connected to an operational amplifier connected for negative feedback with a 470K $\Omega$  resistor in the feedback loop. The gain equation for each frequency range is shown below. The slide potentiometer value is denoted by the variable ‘R’ since its value can be manually changed.

$$Gain = \frac{470K\Omega}{R}$$

### 5.2.5 LED Driver Block

For the LED driver block logic gates and a tricolored LED were used. This LED has three anodes and a common cathode. When a sufficient voltage is applied to each anode, the LED will light up one of three colors. The three colors are red, blue, and green. The color green represents when only the distortion is in use, red represents when only the equalizer is in use, and blue represents when both functions are in use. This is shown in the truth table below.

Table 6: Truth table for the LED logic

Inputs		Outputs		
Distortion	Equalizer	Blue	Red	Green
0	0	0	0	0
1	0	0	0	1
0	1	0	1	0
1	1	1	0	0

From this truth table the circuitry shown in Figure 20 was derived.

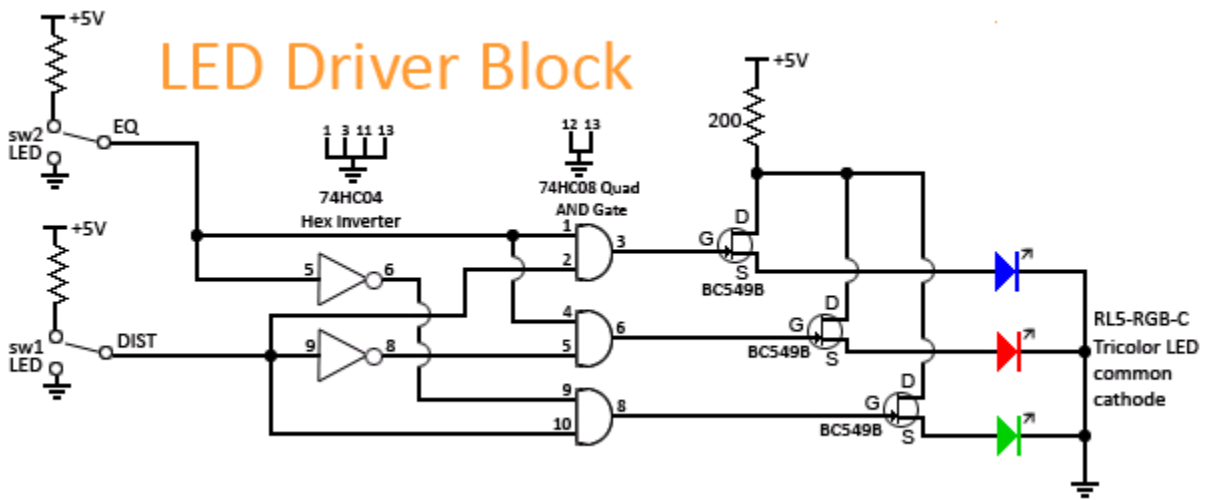

Figure 20: LED logic schematic

The LED logic design required two AND gates and three inverters. The three transistors are included to not load the output of the AND gates and to provide the supply the correct voltage across the LED. The drain of these transistors was connected to 5V through a 200Ω resistor (the red anode of the LED itself has a forward resistance of 100Ω) to limit the current to  $5V/(200+100)\Omega = 17 \text{ mA}$ , which is within the 20mA constant current specification on the tricolor LED specification sheet. The source of the transistors are connected each corresponding LED anode. The blue and green anodes draw less current because the forward resistance of them is 175Ω instead of the 100Ω of the red anode, so they will also be within specification for the LED, as they will be exposed to  $5V/(200+175) = 13 \text{ mA}$ . This was sufficient to light the LED to a viewable level.

### **5.2.6 Switches**

The 3PDT switches in our design are off-board connections. Our pedal is able to switch between the distortion and equalizer modes or have the option to have both functions on together. If neither functions are being used, the pedal has true bypass. To accomplish this two 3PDT (triple pole double throw) switches were used. The switch setup is shown in Figure 21.

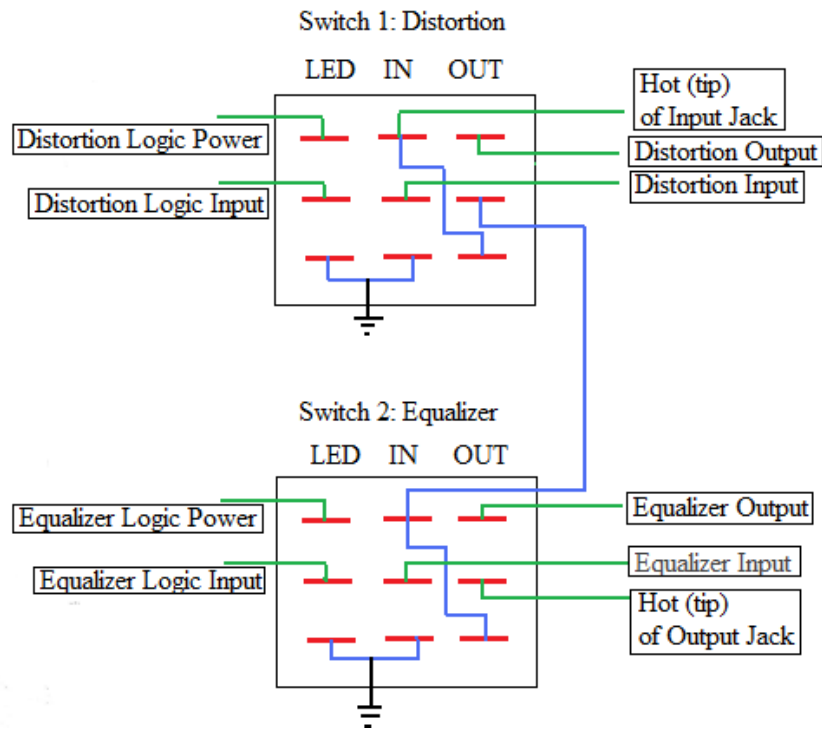

Figure 21: Switch-wiring diagram

The middle row of each switch consists of the poles. The top and bottom positions are the throws. Since there are two positions that the switch can be in, either all three poles in the up position or all three poles in the down position, the switch is three pole double throw, or 3PDT. Both of our switches used the convention of up representing that the particular functional block is in the on position and down as the block being in the off position, or bypassed.

The setups for the distortion and equalizer switches are very similar. The first column is designated to the LED logic, the middle row is the inputs to each block, and the last row is the outputs of each block. When all three poles are in the up position, the functional block is on. In the on position the LED logic is powered with a high logic level (5V) indicating that the functional block is on and to light the LED with the appropriate color. Also in the on position, the input and outputs are connected to the inputs and outputs of that circuit block. When the

switch is in the off (down position), the LED logic and the input to the functional block are grounded, or pulled directly from the circuit. Then the input signal goes straight to the output, where the top middle pin is connected to the lower right pin.

The input to the distortion block is the output signal from an electric guitar. The output of the distortion block goes to the input of the equalizer switch for the on position. The input of the equalizer is the clean guitar signal when the distortion block is off or the distorted signal coming from the distortion block. The output to the amplifier is the clean signal from the guitar if both the distortion and equalizer are off, the distorted signal only if the equalizer is off, and the equalized signal if only the distortion is off. When either the distortion or equalizer blocks are switched off, their inputs are grounded.

### 5.2.7 Jacks

The input and output jacks are off-board connections, similar to the switches. Diagrams of both the input and output jacks are shown in Figure 22.

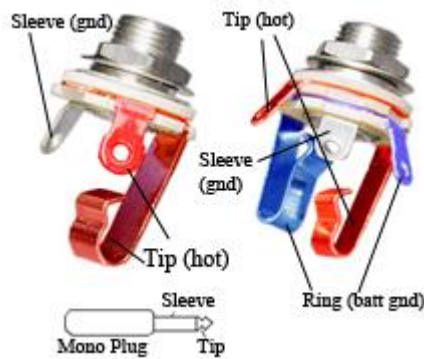

Figure 22: Input jack (right) and output jack (left)

The input jack is a stereo one-quarter inch guitar jack, consisting of three terminals. The sleeve terminal is connected to ground, the ring terminal is connected to the battery ground, and the tip terminal is connected to the signal output of a guitar. Guitar cables have one-quarter inch

mono plugs at each end, plugging a mono cable into a stereo jack shorts the sleeve and ring connections together. This feature connects the battery to the circuit only when a guitar cable is plugged into the input of the pedal, because the sleeve of the cable itself connects the sleeve and ring terminals of the jack. If the cable is not plugged in, the battery is not connected and is not being drained when the pedal is not in use. The output jack is similar to the input jack except that it is only a two terminal device that is connected to the output signal and ground. The plugs on a guitar cable are mono plugs; an image of a mono plug is shown below, along with the input jack and the output jack.



## 6. Product Results

### 6.1 System Testing and Results

The PCB for our final design was created through ExpressPCB, a PCB manufacturing company that provides its own PCB software. A picture of the final PCB design is included in Appendix D. When the PCB arrived all of the parts in our circuit were soldered on. The bottom side of the board, the part that will be screwed to the bottom of the box, is shown in Figure 23. All of the resistors, capacitors, and integrated circuits are on this side. The trim potentiometers are also on the bottom side so the user only has to remove a few screws to open up the box and does not have to remove the circuit board to access to them if they wish to adjust them to customize their sound.



Figure 23: Bottom view of the PCB with parts soldered on

After receiving the PCB, a few problems were immediately discovered with the design. First, the distance between holes for the terminals of the slide potentiometers in our equalizer circuit were miscalculated. Also, the holes on the PCB were not large enough in diameter to fit the pins of the potentiometers. To fix this problem offset pins were soldered to the holes so they

could be slightly bent to compensate for the measurement problems. Figure 24 shows the offset pins. Then the slide potentiometer pins were soldered to the sides of these offsets.

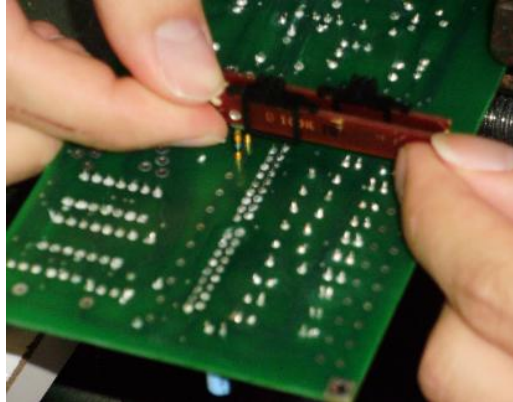

Figure 24: Offset pins to correct potentiometer errors

After all of the parts were soldered onto the PCB, testing on the distortion block of our circuit took place by putting the output jack to the amplifier directly to the output of the distortion circuitry. Initially there were some problems with the tone potentiometer after it had been soldered multiple times, so it was replaced. The distortion circuit sounded better than when it was tested breadboard because there was less capacitance in the board itself than that of the breadboard. The equalizer block was tested by soldering the input jack straight into the input of the equalizer circuitry and the output jack to the output of the equalizer circuit, and testing this configuration with an electric guitar signal. It was found that there was no output signal being sent to the amplifier from the equalizer block. To debug the circuit first our solder connections on the jacks were rechecked. Then the PCB design was checked again to ensure that the placement all of the traces were correct. After verifying that the PCB design and the jacks were correct the slide potentiometers were examined further.

The datasheet of the potentiometers were inspected and it was found that the potentiometers had been wired in backwards. Two rows of pins on the potentiometers needed to

be crossed for ten out of the twelve slide potentiometers in our equalizer circuit. To fix this problem, the slide potentiometers for the equalizer block were soldered onto a perf board and then crossed the wires underneath and soldered them into the offsets. A bottom view of the perf board is shown in Figure 25. The potentiometers are soldered to the top side of the perf board and the two rows of wires on the left side in the picture are to be crossed over into the offset pins on the PCB. At this point only one of these rows had been soldered.

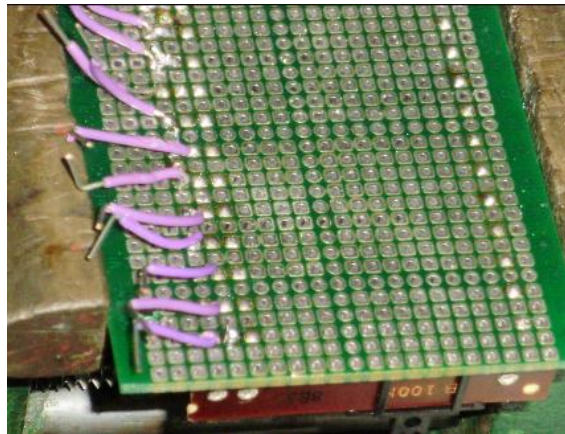

Figure 25: Bottom view of the perf board with the equalizer slide potentiometers

In the final design the the offset pins were desoldered and the wires were soldered directly to the PCB holes. This was because the wires underneath were being bent at angles to fit the offset holes which was putting pressure on the solder joints and the wires themselves, causing some of the wires to break and making it difficult to debug if something went wrong. Removal of the offset pins caused the broken pads on the PCB which needed to be repaired. In the process, there were touch-ups on some of the weak solder connections and found a polarized capacitor that was swelling. Also, a capacitor had been soldered in backwards was replaced.

A top view of our PCB before the switch wiring and bypass circuitry is shown in Figure 26, showing the entire perf board connected and offset from the PCB. It also shows the gain, tone, and volume potentiometers which are off-board connections.

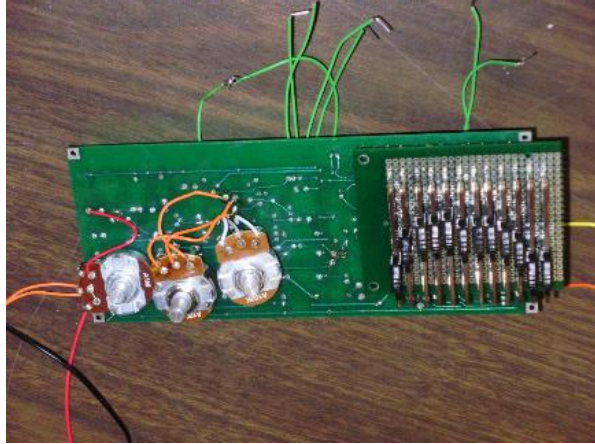

Figure 26: Top view of the final PCB before switch wiring

Figure 27 shows the bottom view of our final PCB before switch wiring. The green wires will be connections to the switches. The wires coming off the left and the right sides of the PCB are for the input and output jacks which are also off-board connections.

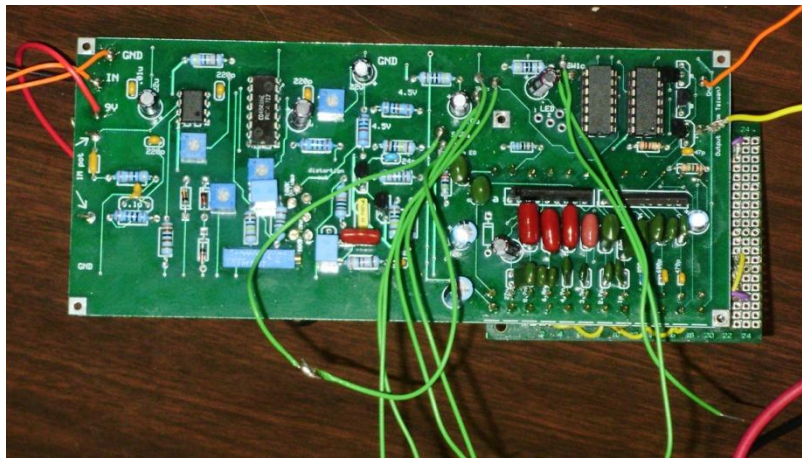

Figure 27: Bottom view of the final PCB before switch wiring

When the slide potentiometers were placed correctly an output signal was obtained from the equalizer block, however, there was a loud squealing noise when one of the potentiometers was slid past a certain point. The squealing noise may have been caused by a dirty potentiometer or a bad connection on the perf board or the PCB.

When the LED circuitry was tested using one of the switches, it was discovered that it worked but the LED was far too dim. The next logical thing to test was the voltage being supplied to our LEDs when they were supposed to be on and it was found that our 4.5V rail was reading 2.2V on the digital multimeter. This is because this “rail” was not really a rail at all, it was actually designed to be a 4.5V reference. The 4.5V reference was set by a simple voltage divider consisting of two resistors in series and was not meant to be loaded, and could not power the LED circuitry. The 4.5V reference issue was fixed by cutting the trace that connects the reference point to the LED driver circuitry and the LED, and replacing it with a 5V linear drop out regulator. This made the LED much brighter because the LDO supplied the proper voltage to the LED circuitry, and took the load off the reference point. The LDO used can supply up to 150mA, which is much more current than our LED block requires. The 4.5V reference was still used to offset the signal midway between the 0-9V rails of the operational amplifier in the distortion block.

When the switches were wired up and the distortion and the equalizer blocks were tested again, it was found that the circuit was making a kind of phasor-like sound that seemed to be sweeping in frequency. It was concluded that the extra noise was created by the wires from the switches and the other off-board connections that were acting as antennae and picking up electromagnetic fields from other nearby electronic devices and the lighting of the room. This problem was solved by placing the circuit in an enclosure, or the metal case of the pedal to block outside disturbance. Also at this point, the distortion block was no longer working properly. When switched on, the distortion could still be heard because part of the signal was passing through to the amplifier, but there seemed to be an intermittent connection somewhere in the distortion block. By following the signal path with a multimeter and moving the output jack to

different parts of the distortion block it was found that the problem lied in a broken potentiometer that was used to control the volume. The potentiometers used for the gain, volume, and tone knobs of the distortion block were much more temperature sensitive than expected. They are very mechanically stable and this mechanical stability had been misinterpreted as thermal resistance also, which caused us to solder and resolder these potentiometers for different uses along the design process without caution to how many times they were soldered to. The material that connects the leads of the potentiometer to the internal parts of them is extremely temperature sensitive and can survive only a few exposures to the high heat necessary for soldering and desoldering. This potentiometer was replaced and the distortion circuitry resumed working as it had been before.

## **6.2 Final Touches**

The enclosure that was chosen to house our PCB was an aluminum box with dimensions of 7.5"x4.3"x2.4" because the PCB itself was 7"x3"x1½" and extra room was needed on the sides and bottom to mount the switches, jacks, and potentiometers. All of the places on the box where the holes would need to be drilled were measured and marked. The most difficult obstacle was drilling the holes for the twelve slide potentiometers in the equalizer block. They were measured several times before they were cut and they still ended up having to be extended by an extra half an inch. Then holes were drilled on the top for the volume, gain, tone potentiometers, LED, and stomp switches. The final product is shown in Figure 28. Notice that the LED is blue indicating that both the distortion and the equalizer functions are in use.



Figure 28: Final pedal in case

The most convenient way to place the jacks was to run the two jacks out of the back of the box, because there was not enough room on the sides of the box. The first holes that were cut for the jacks were too high because it wasn't taken into consideration that the full height of the bottom of the potentiometers for the gain, tone, and volume knobs. To correct this, the holes were drilled directly beneath the original holes. Figure 29 shows the input and output jacks in the back of the box. Here only the input jack is connected to a cable from the guitar, to allow demonstration of the LED function indicator. This is connected because the input cable must be connected to connect the battery to the pedal to power it. Figure 30 shows the pedal in the same switch settings without the input jack plugged in, and the LED is off because the battery is removed from the circuit when a cable is not plugged into the input jack which saves power.



Figure 29: Input and output jacks mounted to the box, the LED is green which indicates that the distortion block is switched on and the equalizer block is in bypass.



Figure 30: LED indicator light is not lit even though the bypass switches have not been adjusted since the previous picture, because the input cable has been removed from the pedal removing power from the circuit.

Standoffs were used to stabilize the perf board with the equalizer slide potentiometer to the PCB and mounted this board to the top of the box with screws. A production model of this pedal would have shorter screws holding the perf board to be more aesthetically pleasing. Then four additional holes were drilled in the bottom of the box to mount the PCB on the bottom. The screws at the bottom come up through the bottom of the box and through the PCB mounting holes inside the box as shown in Figure 31.



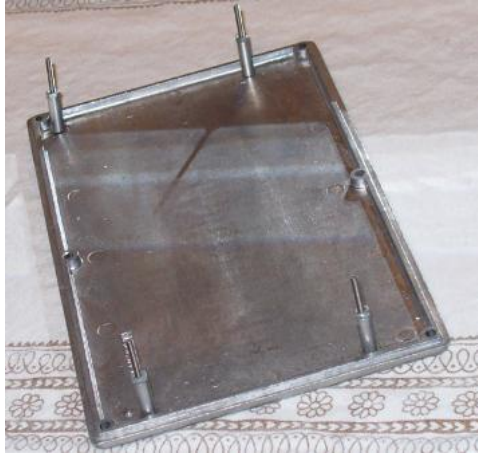

Figure 31: Standoffs and screws mounting the PCB to the bottom of the box

When the box is opened, the user has access to the trim potentiometers to adjust the gain stages in the distortion block. Figure 32 displays the bottom of the box with the cover unscrewed. The trim potentiometers are the short blue devices on the left.



Figure 32: Inside the box

Since this was a prototype, the battery clip remains inside the box, however if our device was marketed the battery would be accessible to the user from the outside of the box.

## **7. Cost Analysis**

### **7.1 Initial Investment**

The final parts list for our design is shown in Appendix C. The total cost of parts to build our design was \$47.84. However, after compensating for the cost of manufacturing and repayment to investors and retailer markup, the shelf price is generally 400% more than the cost of one unit. This means that the shelf price of our product will be approximately \$191.36. This would be ideal to set our product at to compete with other multi-functional pedals on the market. In the Product Specifications section (Section 2.2), the approximated price of the pedal was about \$350, to compete with the combined price of a distortion pedal and a ten-band equalizer pedal sold separately. If our device were marketed, the parts would be bought in bulk since it is cheaper per part, so the parts list in Appendix C also includes bulk prices. It would cost \$37.11 per unit to produce 100 units, \$33.59 per unit to produce 500 units, \$30.43 to produce 1,000 units, and \$26.74 to produce 5,000.

The initial amount that an investor would need to provide to us depends on a few factors. First of all at least four employees would be needed to take care of the finances, legal situations, human resources, and payroll. Our company would need to pay these employees for the first month, so if these employees were earning \$60,000 per year or \$5000 each per month, then at least \$120,000 would be needed for the first six months of employment costs. In addition, a stock of about 5,000 units will be necessary to start the company. These 5,000 units priced at \$26.74 each will cost \$133,700. Also \$3,000 is estimated for a new rental space and for 6 months of rent will be \$18,000. The company would need about \$20,000 for advertising and another \$28,300 for additional overhead costs such as office supplies and any other costs that may arise to ensure that the company has a successful start. This makes the initial investment an even \$320,000.

## 7.2 Return on Investment (ROI)

Our Return on Investments (ROI) chart is shown in Figure 33. The black line shows the initial \$320,000 investment. The product will be put on the market about 5 months after the company is started because there needs to be time designated to produce the units, to find employees, and to settle in a place where the company will be started. The red, green, and blue lines represent the company income when the product is put on the market 5 months after the initial investment is received.

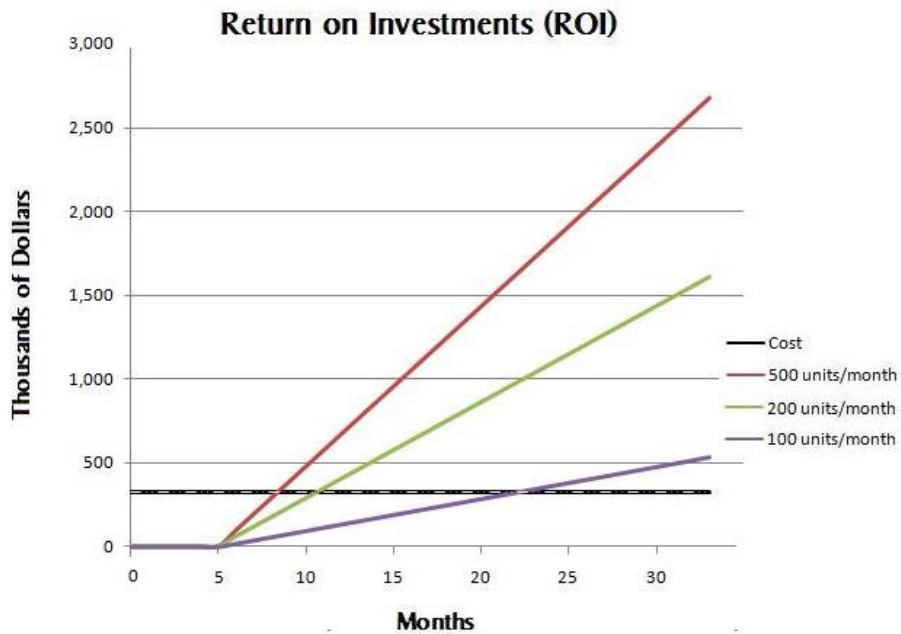

Figure 33: Return on Investment (ROI) Chart for our Product

This Return on Investments chart shows that if 100 units it would take about two years to break even. However, if just 200 pedals sold per month, the company would break even in ten months. Usually investors want to see this behavior happen within two years of the product being on the market, so this would please the investors if this were to happen in a ten month period. Also, selling 200 pedals per month will not be a hard goal to accomplish since our pedal is high quality and the shelf price is very cheap. If 500 units were sold per month the company would break even almost right away after the

product is put on the market. It would only take about 7 months, or two months after the pedal is on the market, for the company to break even.

## **8. Failure and Hazard Analysis**

### **8.1 Safety Considerations**

If the pedal was to go on the market, it would have to comply with the Underwriters Laboratory (UL) and the Institute of Electrical and Electronics Engineers (IEEE) for safety and reliability. Any customer that is buying a product expects their purchase to be safe and free of static hazard. Devices that follow these guidelines will pass certain tests that certify products as safe. The National Electrical Safety Code (NESC) is a division of the IEEE that deals with the safety of products.

To prevent injury, the edges of the aluminum casing are dull and rounded off with no sharp edges. Sharp edges could result in injury when the pedal is being held or carried. The box purchased for our design already had rounded edges. When the holes were cut in the top and sides of the box, the insides of the holes were filed down to remove sharp edges. If the product were to be manufactured in bulk, the box would be designed in a similar safe manner.

One of the biggest concerns about safety amongst electronics is the possibility of electric shock. A rule called “Protective grounding or physical isolation of non-current-carrying metal parts” in the 2007 NESC states that “All metallic guards including rails, screen fences, etc. about electric equipment shall be effectively grounded.” (NESC, 39) To eliminate any static hazards to the user, the box was grounded from the inside. There are clearances of at least a quarter of an inch between all sides of the PCB and the box, preventing any electric signal on the PCB from flowing through the box itself. If the user were to open the box and adjust the trim potentiometers, no hazard would occur because all wires and traces inside are well-insulated. Further precautions could be taken to add a protective layer of a non-conductive material such as rubber or sponge to absorb any exterior shock.

The NESC also states that components should be “of suitable voltage and ampere rating for the circuit in which they are installed” (NESC, 63). All parts of the circuit are designed to exceed component specifications. For example, the 5V LDO can supply 150mA when the driver block of the circuit draws less than 20mA. Also, half-watt resistors and 50V capacitors were used in our prototype, which is much more power handling capability than the components will encounter in the circuit.

## **8.2 Reliability**

Another division of the IEEE is dedicated to the reliability of electronic devices. This covers the reliability of the product to suit the needs of the customer and that the lifetime of the product is reasonable for its application. Reliability was taken into consideration in the pedal design and the pedal is expected to have a long lifetime.

It was considered that the pedal will be repetitively stomped on by the user. Due to the strain imposed on the device by this, the pedal is composed of parts such as the stomp switches and the input and output jacks that are built to handle this repetitive mechanical stress. The stomp switches and jacks were special ordered from an effects pedal manufacturing website to ensure that they were designed to function properly in our design. The jacks are built to handle the mechanical stress of plugging and unplugging the cables. The aluminum casing that the PCB is mounted to is strong enough to handle the stress being applied to it. Most of the mechanical stress is applied to the box itself because the off-board connections such as the jacks, switches, slide potentiometers, and knobs are all mounted to the case.

Temperature is a main factor that could affect the reliability of the electrical components. Heat is produced by current flowing through internal parts. When operating, each of components

generates heat which accumulates in the sealed case of the pedal. The inner temperature of electronic devices can weaken components and shorten their lifetime.

The ambient temperature of the enclosure affects the lifetime of the components of the device. The PCB was designed with sufficient clearance between components to ensure each component has sufficient air circulation and help prevent overheating. Offsets were used for sensitive components so that the components were not directly soldered to the board and were never exposed to the high temperatures of soldering.

## **9. Recommendations**

### **9.1 Device Marketability**

No product exists on the market today with the full functionality of our pedal. Distortion pedals on the market today have much less complex equalization, mostly three or less band equalizers. Many distortion pedals are not even true bypass and have inferior generic sounding distortion that lacks character. The only competing distortion pedals out of the ones examined in the market research section that even close to compare to the full sound and amount of heavy distortion of our pedal are the Electro Harmonix Metal Muff, the Marshall Jackhammer, and the Krank Distortus Maximus. The Metal Muff and the Krank both have retail prices of \$225, putting each of them more expensive than our entire pedal. The Marshall Jackhammer retails at a competitive \$119, but it adds far too much noise to the signal at high gain settings than acceptable, and doesn't provide as much distortion as our pedal unless you drive it with another gain stage by putting another pedal in front of it. Both the Metal Muff and the Krank add a noticeable amount of noise to the signal at high gains when the guitar is not being played also. The only way to compensate for this added noise would be to purchase another effects pedal called a noise gate, which blocks all signal below a certain amplitude threshold from getting through the output of it and ultimately to the amplifier.

Even a thin or muddy sounding distortion can be improved upon with the addition of a properly adjusted ten band equalizer placed in a pedal board after it. Equalization is extremely useful in customizing guitar tone and compensating for the shortcomings of other effects or circuits the pedal boards or amplifiers of guitarists. Ten Band equalizer pedals offer the most customizable equalization in any effects pedal on the market today, but these pedals do not



contain distortion circuitry, and are very expensive. Our pedal offers both a high gain distortion ideal for heavy metal and a ten band equalizer in one enclosure, with true bypass for both.

The distortion block of our pedal is more adjustable and provides more distortion than any competing pedal that was examined in the market research section. The distortion block of our pedal contains multiple gain stages connected in series for maximum distortion. If the user wishes to, they may open the bottom of the pedal and adjust the individual gains and levels of the gain stages to further customize their sound. The CMOS gain stage of the distortion block actually functions as a noise gate, which is a device that many guitarists put in their pedal board after high gain distortion pedals because they block unwanted noise added to the signal when distortion pedals are switched on and the guitar is not being played. A perfect high gain metal sound out of the distortion block alone was achieved. The Equalizer block of our pedal provides 14dB of gain or attenuation to each frequency with reference to the amplitude of the input signal.

Comparable equalizer pedals on the market provide the same functionality at a price that is greater than the estimated retail cost of our entire pedal. The only features that the equalizer examined has that are not featured in our design would be easy to implement in future revisions of our pedal. One of these features is flashing LEDs on the input and output potentiometers to indicate when the input or output stage is clipping, to notify the user to turn the corresponding slide potentiometer down to prevent any undesired clipping from affecting their guitar tone. The other feature is the ability to plug into a wall outlet. The ten band equalizer examined adjusts the amplitude of frequencies that cover the entire audible spectrum for humans, even though for most guitar purposes up to 6.1 kHz is sufficient, because most speakers in guitar amplifiers cut the signal significantly for frequencies over 5-6kHz.

## 9.2 Future Projects

Our pedal is capable of being adjusted for different frequency values if future market research deems that a wider frequency range is necessary. The frequencies are set by capacitor arrangements in the equalizer block, altering the equalization frequencies would be as simple as changing two capacitors per frequency to be adjusted, and this change would have no other effect on the circuit other than changing equalizer frequencies.

The only functionality that separate distortion and equalizer pedals have over our pedal that combines the two is that two separate pedals can be hooked up in two ways: distortion and then equalizer, or equalizer and then distortion. Our pedal can only be hooked up distortion and then equalizer, if both blocks are to be on. This can be changed by adding more switching circuitry to allow either the equalizer or the distortion pedal to be selected as the first circuit for the guitar signal to be sent to inside of the pedal. Generally, most guitarists put equalizer pedals after distortion pedals though, because equalization has the most effect on tone in that configuration.

More possible future added functionality includes the addition of an AC adapter jack to the pedal, so that it may be powered by a wall outlet and would not require batteries. This would require some circuit design consideration to bypass the battery when the device is plugged into the wall. Another improvement could be the implementation of a battery voltage indicator combined with a LM555 oscillator on power supplied to the LED anodes. This would serve as a low battery indicator by flashing the LED when the battery voltage drops below 7.2V, which is a common voltage of a near dead 9V battery. If this oscillator circuit is placed in the right place, it the LED driver block will still function and the correct color will still shine to indicate which blocks of the circuit are turned on, but that color will flash. This allows for a low battery

condition that only uses the LED that already exists in the pedal, without adding further LEDs to the circuit. Also, the LED flashing instead of staying on would consume less power than the normal condition of the LED always being on, which would be beneficial to extend the battery life longer by using less power when the battery is low.

Another experimental addition to our design could include changing the resistor and the capacitor in the feedback loop of the operational amplifier in the equalizer block to increase the gain available at each equalizer frequency, to allow the user to push the equalizer into clipping at individual frequencies, if they desired. Clipping of the signal causes more distortion to be available to the user only if they decide to use it. If the resistor and capacitor are changed to  $1\text{M}\Omega$  and  $47\text{pF}$ , respectively, then the RC constant for the feedback loop of the amplifier remains the same as before the change, and the gain or attenuation of each frequency from approximately four (or 14dB with respect to the input signal magnitude at the input of the equalizer stage) to 11 (or 20dB with respect to the input signal magnitude at the input of the equalizer stage).

## 10. Conclusion

The task undertaken of building a distortion pedal with a ten band equalizer, with functionality comparable to existing pedals on the market today is one that is undertaken by teams of specialized and experienced engineers, with resources far exceeding that available to our group as students. A WPI education provides the foundations for continued learning through practice in the workplace. This project represents our abilities and our research to this point, and serves as the culmination of our education and our transition from students to engineers. Knowledge necessary to build a functioning and marketable distortion pedal is not contained in any lecture or textbook.

As students, our abilities have been tested with many obstacles encountered and overcome from the research of the Boss Metal Zone through the final implementation of the project. The resolution of problems on a timely basis while maintaining a schedule for product completion is an integral aspect of the design process. Time must be budgeted as much as funds for materials, as engineers' time costs money and contributes to design costs of a product. Design costs translate into product cost, which affects product marketability, or the ability of the product to compete in the market. Deployment of a product into the market is a very calculated process in professional companies. The time that a product is to be placed on the market is carefully calculated by marketing departments to maximize profit. Delays caused by poor time management or excessive use of budget funding will affect the ability of the product to adhere to this calculated market deployment date, and will result in loss of profit.

Problems existed but were overcome by the group by the end of the design process. A prototype with functionalities beyond many other similar competing products was produced on schedule. Future improvement potential of the pedal is outlined for further development of this

product beyond what has been accomplished in this product. With some optimization, it is our belief that our product would be in the position to be a very competitive product in the guitar effects market.

## 11. Works Cited

Accredited Standards Committee, "National Electrical Safety Code." C2-2007(2007): 39, 63.

<http://www.instructables.com/id/SHSGOTJFD80OUV6/>

<http://www.diystompboxes.com/pedals/schematics.html>

<http://www.muzique.com/>

<http://www.music123.com/>

<http://tonepad.com/getFile.asp?id=77>

[http://www.doctorproaudio.com/doctor/temas/dynamics-processors-noisegates\\_en.shtml](http://www.doctorproaudio.com/doctor/temas/dynamics-processors-noisegates_en.shtml)

<http://www.freeinfosociety.com/electronics/schempage.php?cat=1>

<http://equalizers.indepthinfo.com/how-equalizer-works.shtml>

<http://equalizers.indepthinfo.com/graphic-equalizer.shtml>

<http://equalizers.indepthinfo.com/terminology.shtml>

<http://www.geofex.com/effxfaq/xffaq.htm>

# A. Appendices

## Appendix A: Research Schematics

### Boss Metal Zone

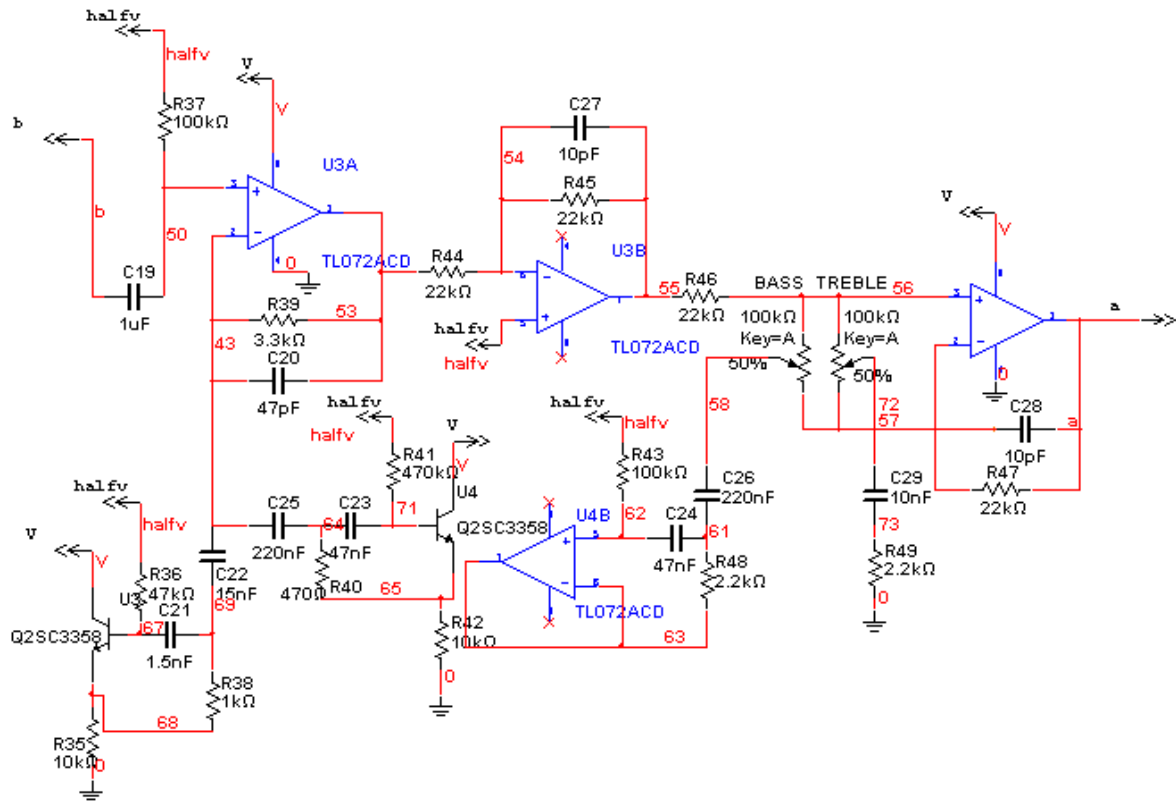

Figure 34: Boss Metal Zone schematic - Part 1

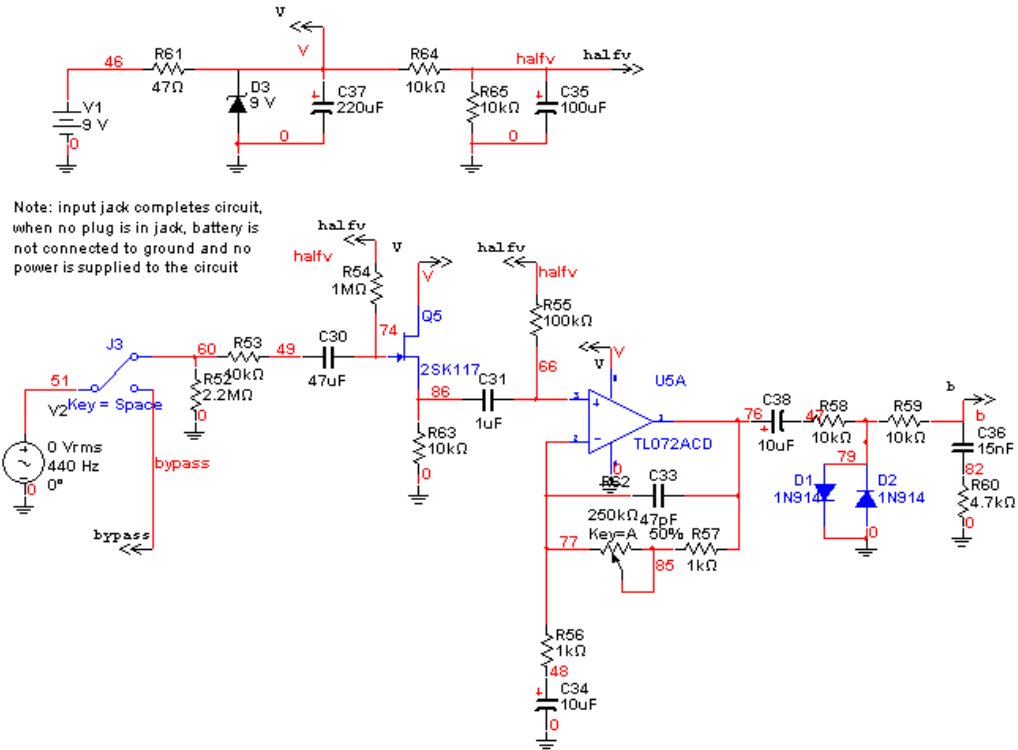

Figure 35: Boss Metal Zone schematic - Part 2

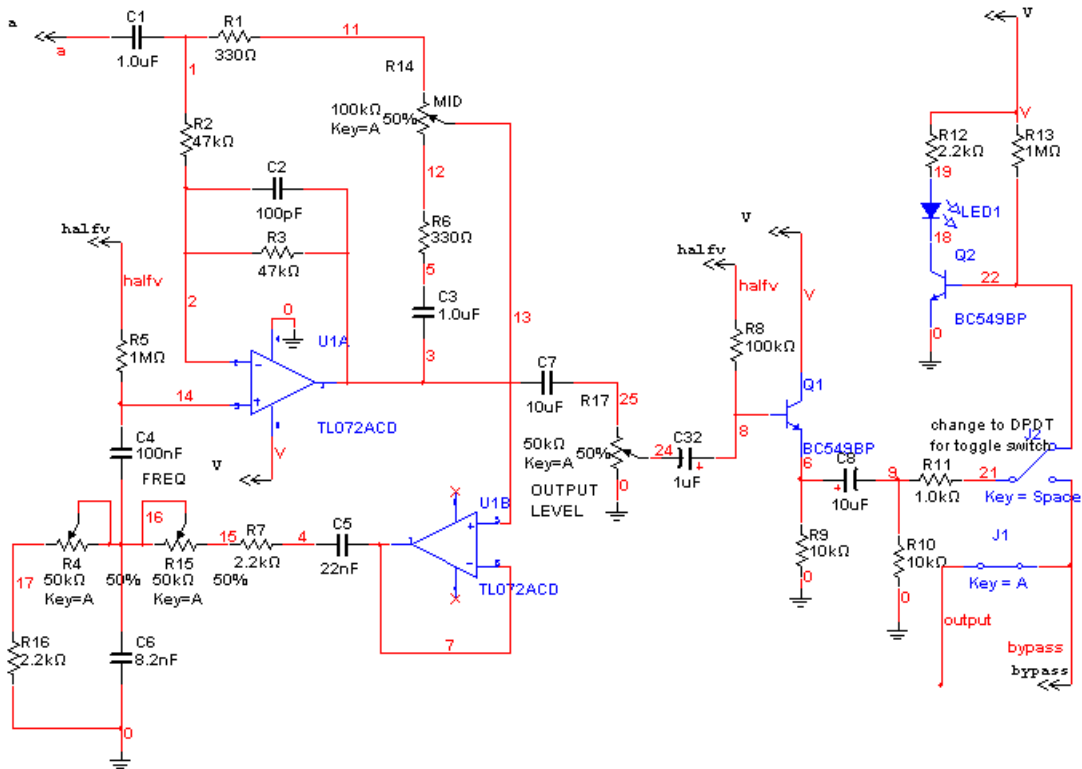

Figure 36: Boss Metal Zone schematic - Part 3



## Insanity Box

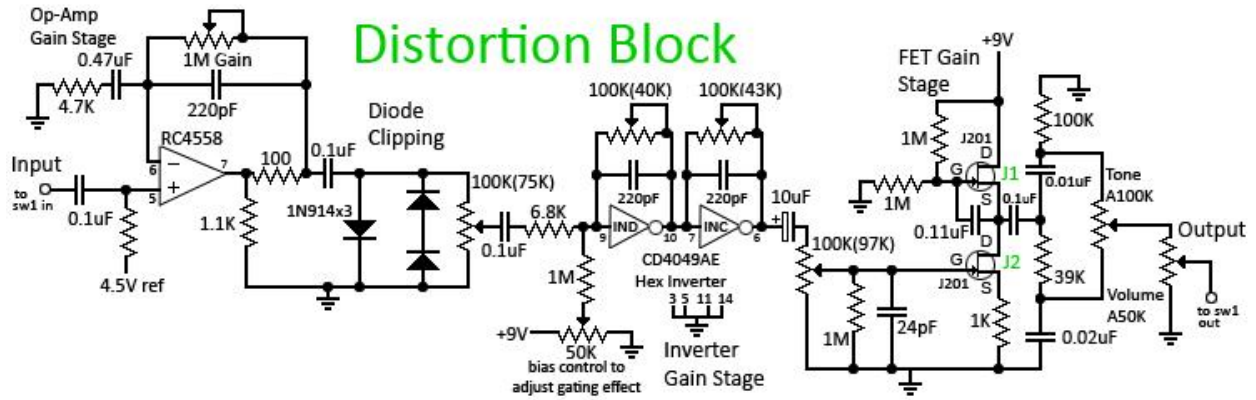

Figure 37: The Insanity Box diction circuitry, our settings for the trim potentiometers are shown in parenthesis

## Ten-Band Equalizer from [buildyourownclone.com](http://buildyourownclone.com)

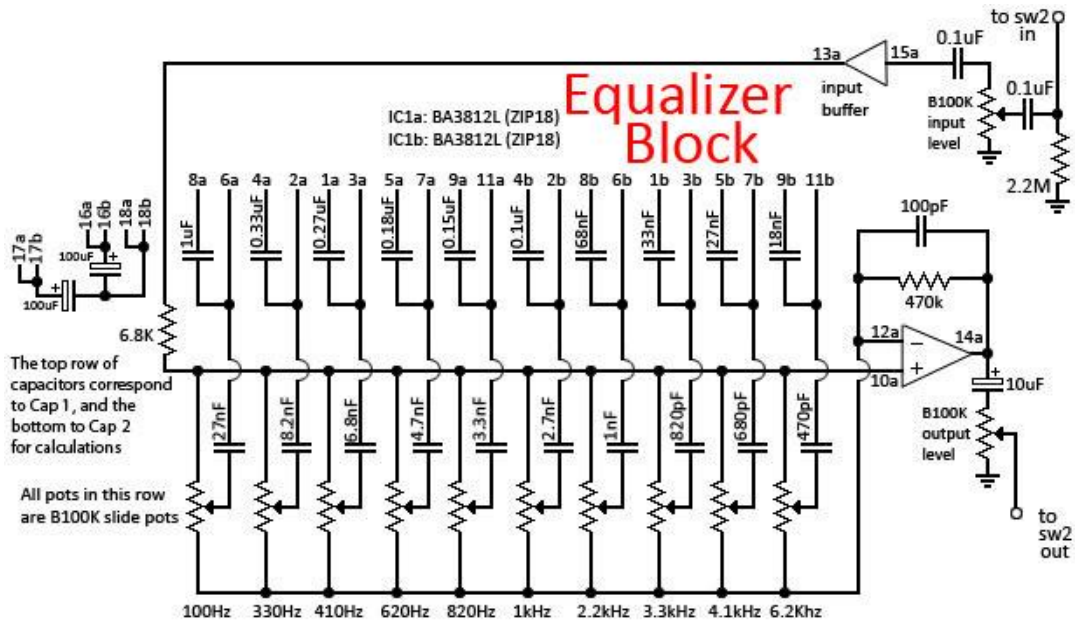

Figure 38: Ten-band graphic equalizer design



## Appendix C: Full Parts List

Distributor	Part Description	Unit Price	Quantity	Total	100	Total	500	Total	1000	Total	5000	Total
Mouser	4.7KΩ 1/4Watt Res.	\$0.09	1	\$0.09	\$0.09	\$0.09	\$0.09	\$0.09	\$0.01	\$0.01	\$0.01	\$0.01
Mouser	470kΩ 1/4Watt Res.	\$0.09	2	\$0.18	\$0.09	\$0.18	\$0.09	\$0.18	\$0.01	\$0.02	\$0.01	\$0.02
Mouser	100Ω 1/4Watt Res.	\$0.09	1	\$0.09	\$0.09	\$0.09	\$0.09	\$0.09	\$0.01	\$0.01	\$0.01	\$0.01
Mouser	1.1KΩ 1/4Watt Res.	\$0.09	1	\$0.09	\$0.09	\$0.09	\$0.09	\$0.09	\$0.01	\$0.01	\$0.01	\$0.01
Mouser	6.8KΩ 1/4Watt Res.	\$0.09	1	\$0.09	\$0.09	\$0.09	\$0.09	\$0.09	\$0.01	\$0.01	\$0.01	\$0.01
Mouser	1MΩ 1/4Watt Res.	\$0.09	4	\$0.36	\$0.09	\$0.36	\$0.09	\$0.36	\$0.01	\$0.05	\$0.01	\$0.04
Mouser	1KΩ 1/4Watt Res.	\$0.09	1	\$0.09	\$0.09	\$0.09	\$0.09	\$0.09	\$0.01	\$0.01	\$0.01	\$0.01
Mouser	100KΩ 1/4Watt Res.	\$0.09	1	\$0.09	\$0.09	\$0.09	\$0.09	\$0.09	\$0.01	\$0.01	\$0.01	\$0.01
Mouser	39KΩ 1/4Watt Res.	\$0.09	1	\$0.09	\$0.09	\$0.09	\$0.09	\$0.09	\$0.01	\$0.01	\$0.01	\$0.01
Mouser	10KΩ 1/4Watt Res.	\$0.09	2	\$0.18	\$0.09	\$0.18	\$0.09	\$0.18	\$0.01	\$0.02	\$0.01	\$0.02
Mouser	200Ω 1/4Watt Res.	\$0.09	2	\$0.18	\$0.09	\$0.18	\$0.09	\$0.18	\$0.01	\$0.02	\$0.01	\$0.02
Mouser	6.8KΩ 1/4Watt Res.	\$0.09	2	\$0.18	\$0.09	\$0.18	\$0.09	\$0.18	\$0.01	\$0.02	\$0.01	\$0.02
Mouser	2.2MΩ 1/4Watt Res.	\$0.09	1	\$0.09	\$0.09	\$0.09	\$0.09	\$0.09	\$0.01	\$0.01	\$0.01	\$0.01
Mouser	470Ω 1/4Watt Res.	\$0.09	1	\$0.09	\$0.09	\$0.09	\$0.09	\$0.09	\$0.01	\$0.01	\$0.01	\$0.01
Mouser	22uF Polarized Cap.	\$0.18	2	\$0.36	\$0.08	\$0.16	\$0.05	\$0.10	\$0.04	\$0.08	\$0.03	\$0.07
Mouser	1uF Polarized Cap.	\$0.20	1	\$0.20	\$0.09	\$0.09	\$0.06	\$0.06	\$0.05	\$0.05	\$0.04	\$0.04
Mouser	100uF Polarized Cap.	\$0.18	2	\$0.36	\$0.16	\$0.32	\$0.14	\$0.28	\$0.10	\$0.20	\$0.07	\$0.14
Mouser	10uF Polarized Cap.	\$0.22	3	\$0.66	\$0.09	\$0.27	\$0.06	\$0.18	\$0.05	\$0.14	\$0.04	\$0.12
Mouser	100pF CD Cap.	\$0.05	1	\$0.05	\$0.05	\$0.05	\$0.03	\$0.03	\$0.02	\$0.02	\$0.02	\$0.02
Mouser	470pF CD Cap.	\$0.10	1	\$0.10	\$0.10	\$0.10	\$0.06	\$0.06	\$0.04	\$0.04	\$0.03	\$0.03
Mouser	680pF CD Cap.	\$0.11	1	\$0.11	\$0.11	\$0.11	\$0.06	\$0.06	\$0.05	\$0.05	\$0.04	\$0.04
Mouser	820pF CD Cap.	\$0.17	1	\$0.17	\$0.17	\$0.17	\$0.11	\$0.11	\$0.10	\$0.10	\$0.08	\$0.08
Mouser	.001uF film Cap.	\$0.12	1	\$0.12	\$0.12	\$0.12	\$0.12	\$0.12	\$0.99	\$0.99	\$0.89	\$0.89
Mouser	.0027uF film Cap.	\$0.16	1	\$0.16	\$0.16	\$0.16	\$0.16	\$0.16	\$0.16	\$0.16	\$0.15	\$0.15
Mouser	.0033uF film Cap.	\$0.10	1	\$0.10	\$0.10	\$0.10	\$0.10	\$0.10	\$0.10	\$0.10	\$0.09	\$0.09
Mouser	.0047uF film Cap.	\$0.17	1	\$0.17	\$0.09	\$0.09	\$0.09	\$0.09	\$0.08	\$0.08	\$0.08	\$0.08
Mouser	.0068uF film Cap.	\$0.23	1	\$0.23	\$0.17	\$0.17	\$0.13	\$0.13	\$0.10	\$0.10	\$0.07	\$0.07

Distributor	Part Description	Unit Price	Quantity	Total	100	Total	500	Total	1000	Total	5000	Total
Mouser	.0082uF film Cap.	\$0.07	1	\$0.07	\$0.06	\$0.06	\$0.05	\$0.05	\$0.04	\$0.04	\$0.04	\$0.04
Mouser	.01uF film Cap.	\$0.29	2	\$0.58	\$0.18	\$0.36	\$0.18	\$0.36	\$0.14	\$0.28	\$0.13	\$0.26
Mouser	.11uF film Cap.	\$0.08	1	\$0.08	\$0.06	\$0.06	\$0.05	\$0.05	\$0.04	\$0.04	\$0.04	\$0.04
Mouser	.018uF film Cap.	\$0.07	1	\$0.07	\$0.06	\$0.06	\$0.04	\$0.04	\$0.04	\$0.04	\$0.03	\$0.03
Mouser	.02uF film Cap.	\$0.19	1	\$0.19	\$0.10	\$0.10	\$0.09	\$0.09	\$0.06	\$0.06	\$0.04	\$0.04
Mouser	.027uF film Cap.	\$0.07	2	\$0.14	\$0.05	\$0.10	\$0.04	\$0.09	\$0.04	\$0.08	\$0.04	\$0.07
Mouser	.033uF film Cap.	\$0.13	1	\$0.13	\$0.12	\$0.12	\$0.10	\$0.10	\$0.09	\$0.09	\$0.07	\$0.07
Mouser	.068uF film Cap.	\$0.12	1	\$0.12	\$0.11	\$0.11	\$0.09	\$0.09	\$0.08	\$0.08	\$0.06	\$0.06
Mouser	.1uF film Cap.	\$0.21	6	\$1.26	\$0.18	\$1.08	\$0.14	\$0.85	\$0.12	\$0.74	\$0.11	\$0.63
Mouser	.15uF film Cap.	\$0.08	1	\$0.08	\$0.06	\$0.06	\$0.05	\$0.05	\$0.04	\$0.04	\$0.04	\$0.04
Mouser	.18uF film Cap.	\$0.26	1	\$0.26	\$0.22	\$0.22	\$0.17	\$0.17	\$0.15	\$0.15	\$0.13	\$0.13
Mouser	.27uF film Cap.	\$0.13	1	\$0.13	\$0.11	\$0.11	\$0.09	\$0.09	\$0.08	\$0.08	\$0.06	\$0.06
Mouser	.33uF film Cap.	\$0.18	1	\$0.18	\$0.15	\$0.15	\$0.12	\$0.12	\$0.10	\$0.10	\$0.09	\$0.09
Mouser	.47pF film Cap.	\$0.25	1	\$0.25	\$0.21	\$0.21	\$0.17	\$0.17	\$0.14	\$0.14	\$0.12	\$0.12
Mouser	220pF film Cap.	\$0.17	3	\$0.52	\$0.17	\$0.52	\$0.12	\$0.35	\$0.11	\$0.32	\$0.10	\$0.29
Mouser	24pF film Cap.	\$0.26	1	\$0.26	\$0.17	\$0.17	\$0.12	\$0.12	\$0.09	\$0.09	\$0.09	\$0.09
Mouser	50K Linear Trim Pot.	\$1.18	1	\$1.18	\$0.98	\$0.98	\$0.84	\$0.84	\$0.73	\$0.73	\$0.70	\$0.70
Mouser	100K Linear Trim Pot.	\$0.75	4	\$3.00	\$0.63	\$2.52	\$0.60	\$2.40	\$0.57	\$2.28	\$0.50	\$2.00
Mouser	50K Audio Pot.	\$2.95	1	\$2.95	\$2.45	\$2.45	\$1.87	\$1.87	\$1.70	\$1.70	\$1.56	\$1.56
Mouser	1M Audio Pot.	\$1.40	1	\$1.40	\$1.02	\$1.02	\$0.94	\$0.94	\$0.88	\$0.88	\$0.77	\$0.77
Mouser	100K Audio Pot.	\$1.50	1	\$1.50	\$1.09	\$1.09	\$1.00	\$1.00	\$0.84	\$0.84	\$0.58	\$0.58
Mouser	B100K Slide Pot.	\$1.13	12	\$13.56	\$0.79	\$9.48	\$0.72	\$8.64	\$0.64	\$7.68	\$0.46	\$5.57
Mouser	1N914 Diode	\$0.05	3	\$0.15	\$0.03	\$0.10	\$0.02	\$0.07	\$0.02	\$0.06	\$0.02	\$0.05
Mouser	J201 FET	\$0.15	2	\$0.30	\$0.11	\$0.22	\$0.07	\$0.13	\$0.06	\$0.12	\$0.05	\$0.11
Mouser	BC549 Transistor	\$0.10	3	\$0.30	\$0.07	\$0.20	\$0.04	\$0.13	\$0.04	\$0.11	\$0.03	\$0.10
Mouser	CD4049AE Inverter	\$0.53	1	\$0.53	\$0.32	\$0.32	\$0.20	\$0.20	\$0.17	\$0.17	\$0.17	\$0.17
Newark	RC4558 Op-amp	\$0.85	1	\$0.85	\$0.74	\$0.74	\$0.74	\$0.74	\$0.74	\$0.74	\$0.69	\$0.69
Octopart	BA3812L EQ	\$1.89	2	\$3.78	\$1.89	\$3.78	\$1.89	\$3.78	\$1.89	\$3.78	\$1.89	\$3.78

Distributor	Part Description	Unit Price	Quantity	Total	100	Total	500	Total	1000	Total	5000	Total
Mouser	74HC08N AND	\$0.40	1	\$0.40	\$0.24	\$0.24	\$0.15	\$0.15	\$0.13	\$0.13	\$0.12	\$0.12
Mouser	74HC04N Inverter	\$0.40	1	\$0.40	\$0.24	\$0.24	\$0.15	\$0.15	\$0.13	\$0.13	\$0.12	\$0.12
Mouser	5V LDO LM2390T-5.0	\$0.54	1	\$0.54	\$0.45	\$0.45	\$0.39	\$0.39	\$0.36	\$0.36	\$0.33	\$0.33
Pedal Parts	3PDT Switch	\$4.00	2	\$8.00	\$3.00	\$6.00	\$3.00	\$6.00	\$3.00	\$6.00	\$3.00	\$6.00
	<b>TOTAL:</b>			\$47.84		\$37.11		\$33.59		\$30.43		\$26.74

## Appendix D: PCB Design

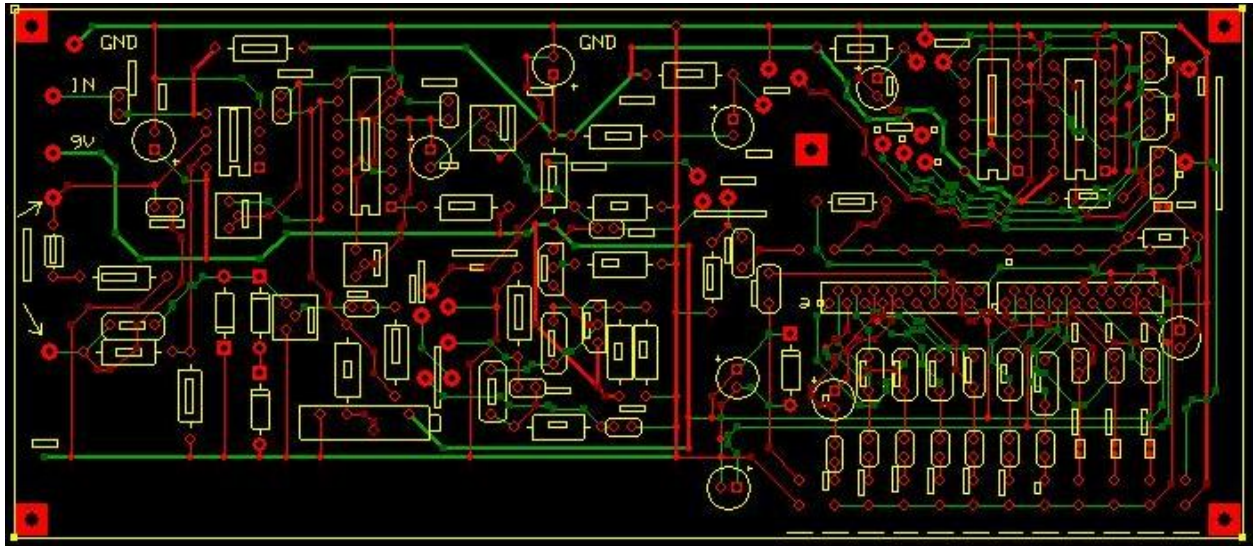

Figure 39: Final PCB design

*Text and component outlines are in yellow. The yellow lines are visible on the solder mask layer of the PCB. The PCB is a two-layered board. Red lines indicate traces on the top of the board and green lines indicate traces on the bottom of the PCB.*

## Appendix E: Datasheets

### 1N914 Diode

DISCRETE SEMICONDUCTORS

# DATA SHEET



## **1N914** High-speed diode

Product specification  
Supersedes data of 1996 Sep 03

1999 May 26

Philips  
Semiconductors



**PHILIPS**

## High-speed diode

1N914

## FEATURES

- Hermetically sealed leaded glass SOD27 (DO-35) package
- High switching speed: max. 4 ns
- Continuous reverse voltage: max. 75 V
- Repetitive peak reverse voltage: max. 100 V
- Repetitive peak forward current: max. 225 mA

## APPLICATIONS

- High-speed switching.

## DESCRIPTION

The 1N914 is a high-speed switching diode fabricated in planar technology, and encapsulated in a hermetically sealed leaded glass SOD27 (DO-35) package.

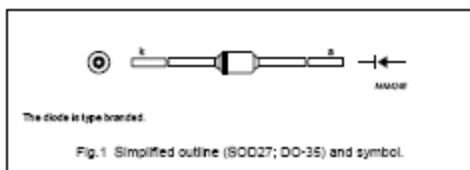

## LIMITING VALUES

In accordance with the Absolute Maximum Rating System (IEC 134).

SYMBOL	PARAMETER	CONDITIONS	MIN.	MAX.	UNIT
$V_{RRM}$	repetitive peak reverse voltage		—	100	V
$V_R$	continuous reverse voltage		—	75	V
$I_F$	continuous forward current	see Fig.2; note 1	—	75	mA
$I_{FSM}$	repetitive peak forward current		—	225	mA
$I_{FSM}$	non-repetitive peak forward current	square wave; $T_J = 25\text{ }^\circ\text{C}$ prior to surge; see Fig.4 $t = 1\text{ }\mu\text{s}$ $t = 1\text{ ms}$ $t = 1\text{ s}$	—	4 1 0.5	A A A
$P_{tot}$	total power dissipation	$T_{amb} = 25\text{ }^\circ\text{C}$ ; note 1	—	250	mW
$T_{stg}$	storage temperature		-65	+200	$^\circ\text{C}$
$T_J$	junction temperature		—	175	$^\circ\text{C}$

## Note

1. Device mounted on an FR4 printed circuit-board; lead length 10 mm.



## High-speed diode

1N914

## ELECTRICAL CHARACTERISTICS

 $T_J = 25\text{ }^\circ\text{C}$  unless otherwise specified.

SYMBOL	PARAMETER	CONDITIONS	MAX.	UNIT
$V_F$	forward voltage	$I_F = 10\text{ mA}$ ; see Fig.3	1	V
$I_R$	reverse current	see Fig.5 $V_R = 20\text{ V}$ $V_R = 75\text{ V}$ $V_R = 20\text{ V}$ ; $T_J = 150\text{ }^\circ\text{C}$	25 5 50	nA $\mu\text{A}$ $\mu\text{A}$
$C_D$	diode capacitance	$f = 1\text{ MHz}$ ; $V_R = 0$ ; see Fig.6	4	pF
$t_{rr}$	reverse recovery time	when switched from $I_F = 10\text{ mA}$ to $I_R = 10\text{ mA}$ ; $R_L = 100\ \Omega$ ; measured at $I_R = 1\text{ mA}$ ; see Fig.7	8	ns
		when switched from $I_F = 10\text{ mA}$ to $I_R = 50\text{ mA}$ ; $R_L = 100\ \Omega$ ; measured at $I_R = 1\text{ mA}$ ; see Fig.7	4	ns
$V_R$	forward recovery voltage	when switched from $I_F = 50\text{ mA}$ ; $t_r = 20\text{ ns}$ ; see Fig.8	2.5	V

## THERMAL CHARACTERISTICS

SYMBOL	PARAMETER	CONDITIONS	VALUE	UNIT
$R_{th(j-c)}$	thermal resistance from junction to tie-point	lead length 10 mm	240	K/W
$R_{th(j-a)}$	thermal resistance from junction to ambient	lead length 10 mm; note 1	500	K/W

## Note

- Device mounted on a printed circuit-board without metallization pad.



J201  
J202



MMBFJ201  
MMBFJ202

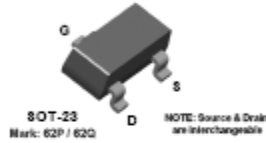

### N-Channel General Purpose Amplifier

This device is designed primarily for low level audio and general purpose applications with high impedance signal sources. Sourced from Process 52.

#### Absolute Maximum Ratings\* TA = 25°C unless otherwise noted

Symbol	Parameter	Value	Units
$V_{GS}$	Drain-Gate Voltage	40	V
$V_{GS}$	Gate-Source Voltage	-40	V
$I_{GS}$	Forward Gate Current	50	mA
$T_{J, Storage}$	Operating and Storage Junction Temperature Range	-55 to +150	°C

\* These ratings are limiting values above which the serviceability of any semiconductor device may be impaired.

**NOTES:**

- 1) These ratings are based on a maximum junction temperature of 150 degrees C.
- 2) These are steady state limits. The factory should be consulted on applications involving pulsed or low duty cycle operations.

#### Thermal Characteristics TA = 25°C unless otherwise noted

Symbol	Characteristic	Max		Units
		J202-208	*MMBFJ202-208	
$P_D$	Total Device Dissipation Derate above 25°C	625 5.0	350 2.8	mW mW/°C
$R_{JC}$	Thermal Resistance, Junction to Case	125		°C/W
$R_{JA}$	Thermal Resistance, Junction to Ambient	357	556	°C/W

\* Device mounted on FR-4 PCB 1.6" X 1.6" X 0.061"

**N-Channel General Purpose Amplifier**  
(continued)

**Electrical Characteristics** T<sub>A</sub> = 25°C unless otherwise noted

Symbol	Parameter	Test Conditions	Min	Max	Units	
<b>OFF CHARACTERISTICS</b>						
V <sub>GS(BR)</sub>	Gate-Source Breakdown Voltage	I <sub>D</sub> = -1.0 μA, V <sub>DS</sub> = 0	-40		V	
I <sub>GR</sub>	Gate Reverse Current	V <sub>GS</sub> = -20 V, V <sub>DS</sub> = 0		-100	μA	
V <sub>GS(0V)</sub>	Gate-Source Cutoff Voltage	V <sub>DS</sub> = 20 V, I <sub>D</sub> = 10 nA	201 202	-0.3 -0.8	-1.5 -4.0	V
<b>ON CHARACTERISTICS</b>						
I <sub>DSS</sub>	Zero-Gate Voltage Drain Current*	V <sub>GS</sub> = 20 V, I <sub>GS</sub> = 0	201 202	0.2 0.9	1.0 4.5	mA mA
<b>SMALL SIGNAL CHARACTERISTICS</b>						
y <sub>fs</sub>	Forward Transfer Admittance	V <sub>GS</sub> = 20 V, f = 1.0 kHz	201 202	500 1000	μmhos μmhos	

\*Pulse Test Pulse Width ≤ 300 μs

**Typical Characteristics**

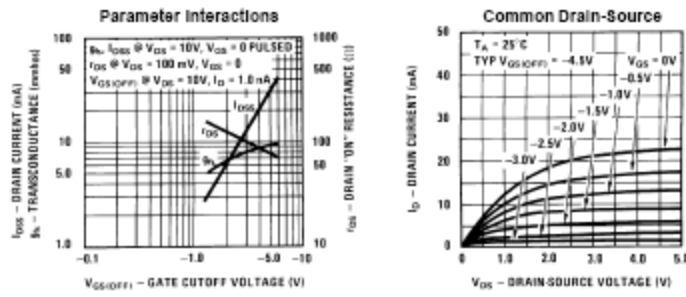

J201 / J202 / MMBFJ201 / MMBFJ202

N-Channel General Purpose Amplifier  
(continued)

Typical Characteristics (continued)

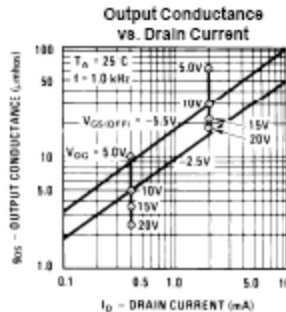
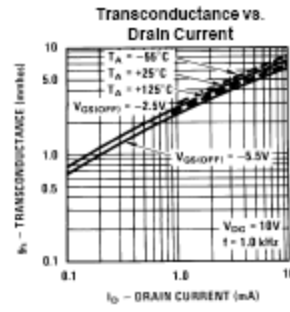
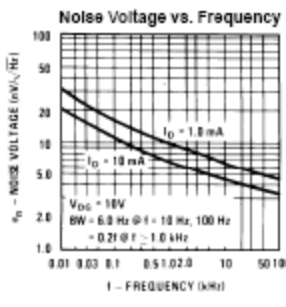
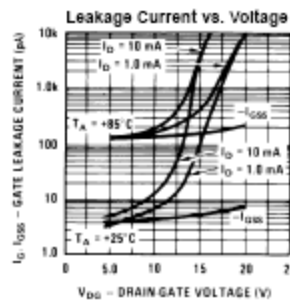
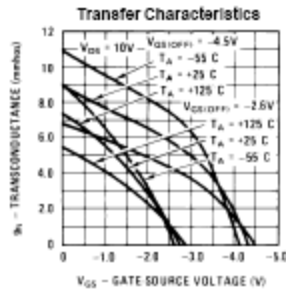
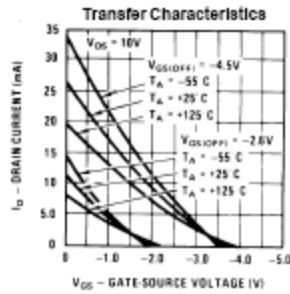

J201 / J202 / MMBFJ201 / MMBFJ202

N-Channel General Purpose Amplifier  
(continued)

Typical Characteristics (continued)

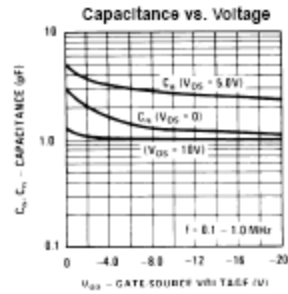

Common Source Characteristics

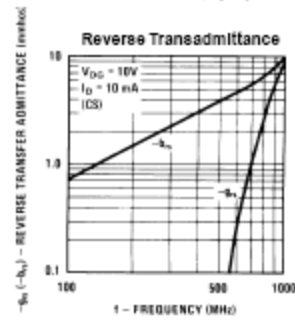
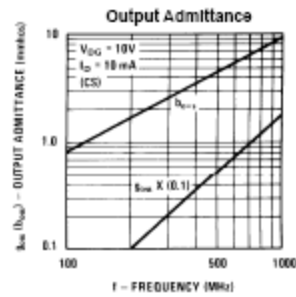
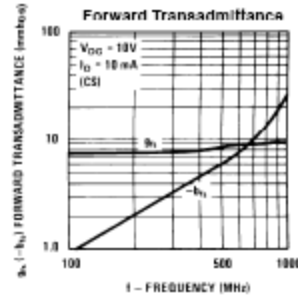
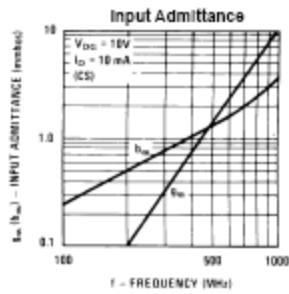

N-Channel General Purpose Amplifier  
(continued)

Common Gate Characteristics

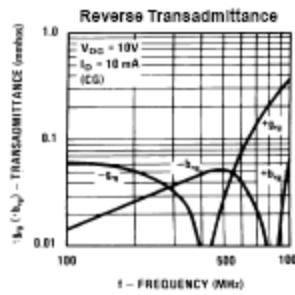
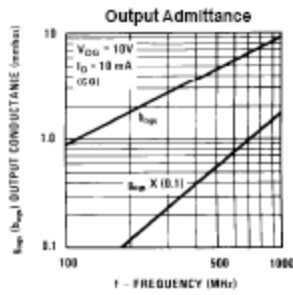
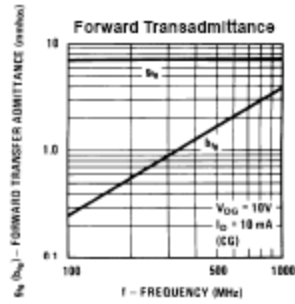
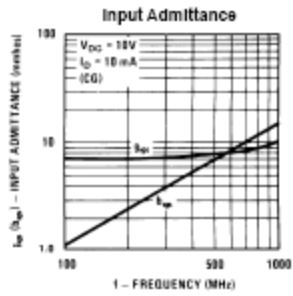

J201 / J202 / MMBFJ201 / MMBFJ202

BC549 Transistor

**DISCRETE SEMICONDUCTORS**

**DATA SHEET**

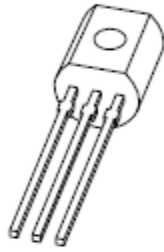

**BC549; BC550**  
NPN general purpose transistors

Product specification  
Supersedes data of 1997 Jun 20

1999 Apr 22

Philips  
Semiconductors



**PHILIPS**

**NPN general purpose transistors**

**BC549; BC550**

**FEATURES**

- Low current (max. 100 mA)
- Low voltage (max. 45 V).

**APPLICATIONS**

- Low noise stages in audio frequency equipment.

**DESCRIPTION**

NPN transistor in a TO-92; SOT54 plastic package.  
PNP complements: BC559 and BC560.

**PINNING**

PIN	DESCRIPTION
1	emitter
2	base
3	collector

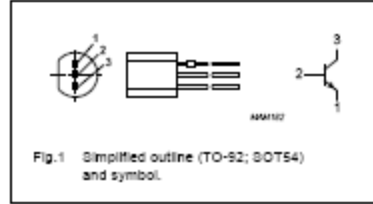

**LIMITING VALUES**

In accordance with the Absolute Maximum Rating System (IEC 134).

SYMBOL	PARAMETER	CONDITIONS	MIN.	MAX.	UNIT
V <sub>CB0</sub>	collector-base voltage	open emitter	–	30	V
	BC549		–	50	V
V <sub>CE0</sub>	collector-emitter voltage	open base	–	30	V
	BC549		–	45	V
V <sub>EB0</sub>	emitter-base voltage	open collector	–	5	V
I <sub>C</sub>	collector current (DC)		–	100	mA
I <sub>CM</sub>	peak collector current		–	200	mA
I <sub>BM</sub>	peak base current		–	200	mA
P <sub>Tot</sub>	total power dissipation	T <sub>amb</sub> ≤ 25 °C; note 1	–	500	mW
T <sub>stg</sub>	storage temperature		–65	+150	°C
T <sub>J</sub>	junction temperature		–	150	°C
T <sub>amb</sub>	operating ambient temperature		–65	+150	°C

**Note**

1. Transistor mounted on an FR4 printed-circuit board.



## NPN general purpose transistors

BC549; BC550

## THERMAL CHARACTERISTICS

SYMBOL	PARAMETER	CONDITIONS	VALUE	UNIT
$R_{th(j-a)}$	thermal resistance from junction to ambient	note 1	250	K/W

## Note

1. Transistor mounted on an FR4 printed-circuit board.

## CHARACTERISTICS

$T_J = 25\text{ }^\circ\text{C}$  unless otherwise specified.

SYMBOL	PARAMETER	CONDITIONS	MIN.	TYP.	MAX.	UNIT
$I_{CBO}$	collector cut-off current	$I_B = 0; V_{CB} = 30\text{ V}$	–	–	15	nA
		$I_B = 0; V_{CB} = 30\text{ V}; T_J = 150\text{ }^\circ\text{C}$	–	–	5	$\mu\text{A}$
$I_{EBO}$	emitter cut-off current	$I_C = 0; V_{EB} = 5\text{ V}$	–	–	100	nA
$h_{FE}$	DC current gain BC549C; BC550C	$I_C = 10\text{ }\mu\text{A}; V_{CE} = 5\text{ V};$ see Fig.2	–	270	–	
		$I_C = 2\text{ mA}; V_{CE} = 5\text{ V};$ see Fig.2	420	520	800	
$V_{CE(sat)}$	collector-emitter saturation voltage	$I_C = 10\text{ mA}; I_B = 0.5\text{ mA}$	–	90	250	mV
		$I_C = 100\text{ mA}; I_B = 5\text{ mA}$	–	200	600	mV
$V_{BE(sat)}$	base-emitter saturation voltage	$I_C = 10\text{ mA}; I_B = 0.5\text{ mA};$ note 1	–	700	–	mV
		$I_C = 100\text{ mA}; I_B = 5\text{ mA};$ note 1	–	900	–	mV
$V_{BE}$	base-emitter voltage	$I_C = 2\text{ mA}; V_{CE} = 5\text{ V};$ note 2	580	660	700	mV
		$I_C = 10\text{ mA}; V_{CE} = 5\text{ V};$ note 2	–	–	770	mV
$C_c$	collector capacitance	$I_B = I_C = 0; V_{CB} = 10\text{ V}; f = 1\text{ MHz}$	–	1.5	–	pF
$C_e$	emitter capacitance	$I_C = I_B = 0; V_{BE} = 0.5\text{ V}; f = 1\text{ MHz}$	–	11	–	pF
$f_T$	transition frequency	$I_C = 10\text{ mA}; V_{CE} = 5\text{ V};$ $f = 100\text{ MHz}$	100	–	–	MHz
F	noise figure	$I_C = 200\text{ }\mu\text{A}; V_{CE} = 5\text{ V};$ $R_B = 2\text{ k}\Omega; f = 10\text{ Hz to }15.7\text{ kHz}$	–	–	4	dB
		$I_C = 200\text{ }\mu\text{A}; V_{CE} = 5\text{ V};$ $R_B = 2\text{ k}\Omega; f = 1\text{ kHz}; B = 200\text{ Hz}$	–	–	4	dB

## Notes

1.  $V_{BE(sat)}$  decreases by about 1.7 mV/K with increasing temperature.
2.  $V_{BE}$  decreases by about 2 mV/K with increasing temperature.

**CD4049A, CD4050A Types**

**CMOS Hex Buffer/Converters**

CD4049A—Inverting Type  
 CD4050A—Non-Inverting Type

The CD4049A and CD4050A are inverting and non-inverting hex buffers, respectively, and feature logic-level conversion using only one supply voltage ( $V_{CC}$ ). The input-signal high level ( $V_{IH}$ ) can exceed the  $V_{CC}$  supply voltage when these devices are used for logic-level conversions. These devices are intended for use as CMOS to DTL/TTL converters and can drive directly two DTL/TTL loads. ( $V_{CC}=5\text{ V}$ ,  $V_{OL}>0.4\text{ V}$ , and  $I_{DN}>3.2\text{ mA}$ .)

The CD4049A and CD4050A are designated as replacements for CD4009A and CD4010A, respectively. Because the CD4049A and CD4050A require only one power supply, they are preferred over the CD4009A and CD4010A and should be used in place of the CD4009A and CD4010A in all inverter, current driver, or logic-level conversion applications. In these applications the CD4049A and CD4050A are pin compatible with the CD4009A and CD4010A respectively, and can be substituted for these devices in existing as well as in new designs. Terminal No. 16 is not connected internally on the CD4049A or CD4050A, therefore, connection to this terminal is of no consequence to circuit operation. For applications not requiring high sink-current or voltage conversion, the CD4069 Hex Inverter is recommended.

These types are supplied in 16-lead hermetic dual-in-line ceramic packages (D and F suffixes), 16-lead dual-in-line plastic package (E suffix), 16-lead ceramic flat packages (K suffix), and in chip form (H suffix).

**Features:**

- High sink current for driving 2 TTL loads
- High-to-low level logic conversion
- Quiescent current specified to 15 V
- Maximum input leakage of 1  $\mu\text{A}$  at 15 V (full package-temperature range)

**Applications:**

- CMOS to DTL/TTL hex converter
- CMOS current "sink" or "source" driver
- CMOS high-to-low logic-level converter

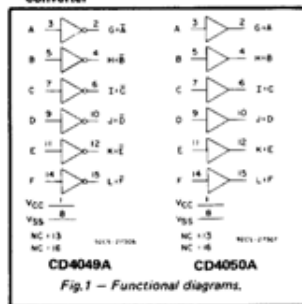

RECOMMENDED OPERATING CONDITIONS at  $T_A=25^\circ\text{C}$ , Except as Noted.  
 For maximum reliability, nominal operating conditions should be selected so that operation is always within the following ranges:

CHARACTERISTIC	LIMITS		UNITS
	Min.	Max.	
Supply-Voltage Range ( $V_{CC}$ ) (For $T_A$ , Full Package-Temperature Range)	3	12	V
Input Voltage Range ( $V_I$ )	$V_{CC}^*$	12	V

\*The CD4049 and CD4050 have high-to-low level voltage conversion capability but not low-to-high-level, therefore it is recommended that  $V_I \geq V_{CC}$ .

**STATIC ELECTRICAL CHARACTERISTICS**

Characteristic	Conditions		Limits at Indicated Temperatures ( $^\circ\text{C}$ )								Units	
			D, F, K, H Packages						E Package			
			$V_O$ (V)	$V_{IN}$ (V)	$V_{CC}$ (V)	-55	+25	+125	-40	+25		+85
Quiescent Device Current, $I_Q$ Max.	—	—	5	0.3	0.01	0.3	20	3	0.03	3	42	$\mu\text{A}$
	—	—	10	0.5	0.01	0.5	30	5	0.05	5	70	
	—	—	15	10	0.02	10	100	50	0.05	50	500	
Output Voltage: Low-Level, $V_{OL}$	—	0, 5	5	0 Typ.; 0.05 Max.								V
	—	0, 10	10	0 Typ.; 0.05 Max.								
High-Level, $V_{OH}$	—	0, 5	5	4.95 Min.; 5 Typ.								
	—	0, 10	10	9.95 Min.; 10 Typ.								
Noise Immunity: Inputs Low, $V_{NL}$	3.6	—	5	1.5 Min.; 2.25 Typ.								V
CD4050A	7.2	—	10	3 Min.; 4.5 Typ.								
Inputs High, $V_{NH}$	1.4	—	5	1.5 Min.; 2.25 Typ.								
All Types	2.8	—	10	3 Min.; 4.5 Typ.								
Inputs Low, $V_{NL}$	3.6	—	5	1 Min.; 1.5 Typ.								V
CD4049A	7.2	—	10	2 Min.; 3 Typ.								
Noise Margin: Inputs Low, $V_{NML}$ Min.	4.5	—	5	1 Min.								V
CD4050A	9	—	10	1 Min.								
Inputs High, $V_{NMH}$ Min.	0.5	—	5	1 Min.								
CD4050A	1	—	10	1 Min.								
Output Drive Current: N-Channel (Sink), $I_{DN}$ Min.	0.4	—	4.5	3.3	5.2	2.6	1.8	3.1	5.2	2.6	2.1	mA
	0.4	—	5	3.75	6	3	2.1	3.6	6	3	2.5	
P-Channel (Source), $I_{DP}$ Min.	4.5	—	5	-0.62	-1	-0.5	-0.35	-0.8	-1	-0.5	-0.4	
	2.5	—	5	-1.85	-2.5	-1.25	-0.9	-1.5	-2.5	-1.25	-1	
Input Leakage Current, $I_{IL}$ , $I_{IH}$ Max.	Any Input	15	$\pm 10^{-5}$ Typ., $\pm 1$ Max.								$\mu\text{A}$	

## CD4049A, CD4050A Types

### MAXIMUM RATINGS, Absolute-Maximum Values:

STORAGE TEMPERATURE RANGE ( $T_{STG}$ )	-65 to +150°C
OPERATING TEMPERATURE RANGE ( $T_A$ )	
PACKAGE TYPES D, F, K, H	-55 to +125°C
PACKAGE TYPE E	-40 to +85°C
DC SUPPLY-VOLTAGE RANGE, ( $V_{DD}$ ) (Voltage referenced to $V_{SS}$ Terminal)	-0.5 to +15 V
POWER DISSIPATION PER PACKAGE ( $P_D$ )	
FOR $T_A = -40$ to $+60^\circ\text{C}$ (PACKAGE TYPE E)	500 mW
FOR $T_A = -50$ to $+85^\circ\text{C}$ (PACKAGE TYPE E)	Derate Linearly at 12 mW/°C to 200 mW
FOR $T_A = -55$ to $+100^\circ\text{C}$ (PACKAGE TYPES D, F, K)	500 mW
FOR $T_A = -50$ to $+125^\circ\text{C}$ (PACKAGE TYPES D, F, K)	Derate Linearly at 12 mW/°C to 200 mW
DEVICE DISSIPATION PER OUTPUT TRANSISTOR FOR $T_A = \text{FULL PACKAGE TEMPERATURE RANGE (ALL PACKAGE TYPES)}$	100 mW
INPUT VOLTAGE RANGE, ALL INPUTS	-0.5 to $V_{DD} + 0.5$ V
LEAD TEMPERATURE (DURING SOLDERING) At distance 1/16 ± 1/32 inch (1.59 ± 0.39 mm) from case for 10 s max.	+265°C

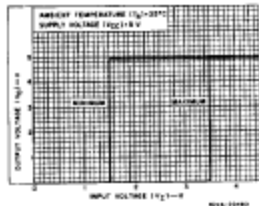

Fig. 3—Minimum and maximum voltage transfer characteristics for CD4050A.

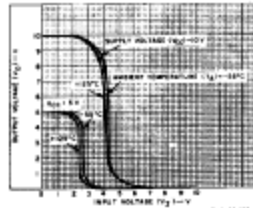

Fig. 6—Typical voltage transfer characteristics as a function of temperature for CD4049A.

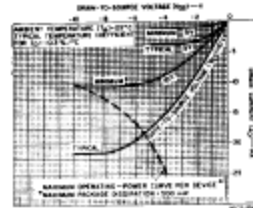

Fig. 9—Typical and minimum p-channel drain characteristics as a function of gate-to-source voltage ( $V_{GS}$ ) for CD4049A, CD4050A.

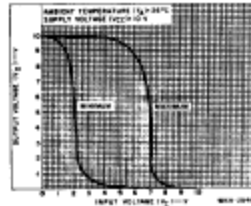

Fig. 4—Minimum and maximum voltage transfer characteristics for CD4049A.

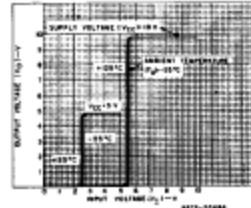

Fig. 7—Typical voltage transfer characteristics as a function of temperature for CD4050A.

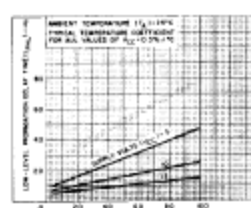

Fig. 10—Typical high-to-low level propagation delay time vs.  $C_L$  for CD4049A.

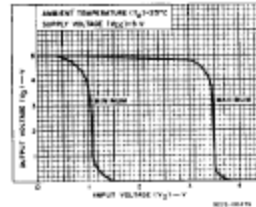

Fig. 2—Minimum and maximum voltage transfer characteristics for CD4049A.

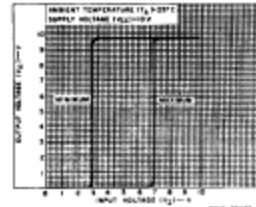

Fig. 5—Minimum and maximum voltage transfer characteristics for CD4050A.

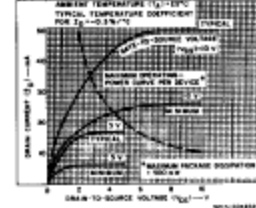

Fig. 8—Typical and minimum n-channel drain characteristics as a function of gate-to-source voltage ( $V_{GS}$ ) for CD4049A, CD4050A.

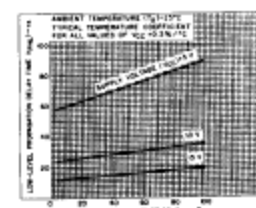

Fig. 11—Typical high-to-low level propagation delay time vs.  $C_L$  for CD4050A.

## CD4049A, CD4050A Types

DYNAMIC ELECTRICAL CHARACTERISTICS at  $T_A=25^\circ\text{C}$ ; Input  $t_r, t_f=20\text{ ns}$ ,  
 $C_L=15\text{ pF}$ ,  $R_1=200\text{ k}\Omega$

CHARACTERISTIC	CONDITIONS		LIMITS ALL PKGS.		UNITS
	$V_I$	$V_{CC}$	Typ.	Max.	
Propagation Delay Time: Low-to-High, $t_{PLH}$	CD4049A	5 5	50	80	ns
		10 10	25	55	
	CD4050A	5 5	75	140	
		10 10	35	85	
High-to-Low, $t_{PHL}$	CD4049A	5 5	15	55	ns
		10 10	10	30	
	CD4050A	5 5	55	110	
		10 10	25	55	
Transition Time: Low-to-High, $t_{TLH}$	CD4049A	5 5	50	100	ns
		10 10	30	60	
	CD4050A	5 5	20	45	
		10 10	16	40	
Input Capacitance, $C_i$	CD4049A	—	15	—	pF
	CD4050A	—	5	—	

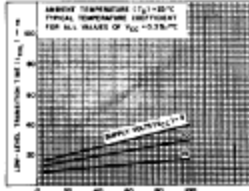

Fig. 14—Typical high-to-low level transition time vs.  $C_L$  for CD4049A, CD4050A.

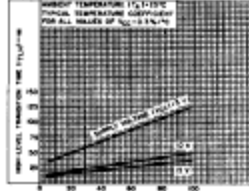

Fig. 15—Typical low-to-high level transition time vs.  $C_L$  for CD4049A, CD4050A.

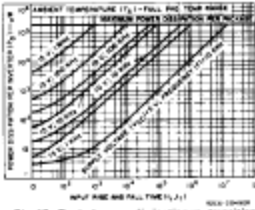

Fig. 17—Typical power dissipation vs. transition time per inverter CD4049A.

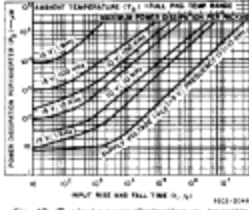

Fig. 18—Typical power dissipation vs. transition time per inverter CD4050A.

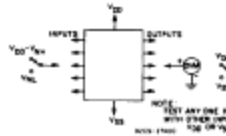

Fig. 19—Noise immunity test circuit.

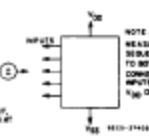

Fig. 20—Input leakage current test circuit.

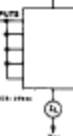

Fig. 21—Quiescent device current test circuit.

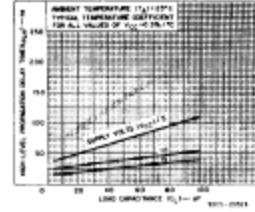

Fig. 12—Typical low-to-high level propagation delay time vs.  $C_L$  for CD4049A.

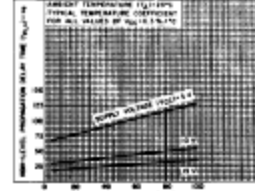

Fig. 13—Typical low-to-high level propagation delay time vs.  $C_L$  for CD4050A.

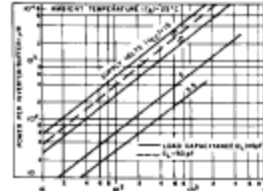

Fig. 16—Typical dispersion characteristics for CD4049A, CD4050A.

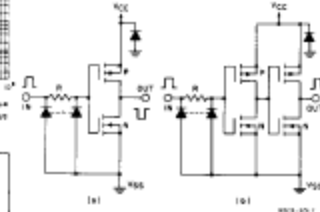

Fig. 22—(a) Schematic diagram of CD4049A, 1 of 8 identical units.  
 (b) Schematic diagram of CD4050A, 1 of 8 identical units.

## CD4049A, CD4050A Types

DYNAMIC ELECTRICAL CHARACTERISTICS at  $T_A=25^\circ\text{C}$ ; Input  $t_p, t_r=20\text{ ns}$ ,  $C_L=15\text{ pF}$ ,  $R_L=200\text{ k}\Omega$

CHARACTERISTIC	CONDITIONS		LIMITS ALL PKGS.		UNITS			
	$V_I$	$V_{CC}$	Typ.	Max.				
Propagation Delay Time: Low-to-High, $t_{PLH}$	CD4049A	5	5	50	80	ns		
		10	10	25	55			
	CD4050A	5	5	75	140			
		10	10	35	85			
	High-to-Low, $t_{PHL}$	CD4049A	5	5	15		55	ns
			10	10	10		30	
CD4050A		5	5	55	110			
		10	10	25	55			
Transition Time: Low-to-High, $t_{TLH}$			5	5	50	100	ns	
			10	10	30	60		
		5	5	20	45			
		10	10	16	40			
	Input Capacitance, $C_i$	CD4049A	—	—	15	—		pF
		CD4050A	—	—	5	—		

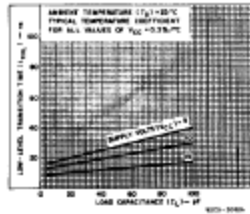

Fig. 14—Typical low-to-high level propagation delay vs.  $C_L$  for CD4049A, CD4050A.

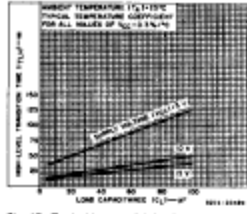

Fig. 15—Typical high-to-low level propagation delay vs.  $C_L$  for CD4049A, CD4050A.

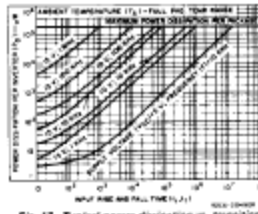

Fig. 17—Typical power dissipation vs. transition time per inverter CD4049A.

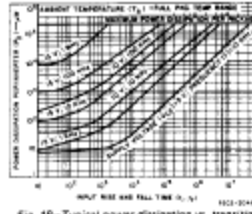

Fig. 18—Typical power dissipation vs. transition time per inverter CD4050A.

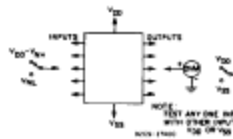

Fig. 19—Noise immunity test circuit.

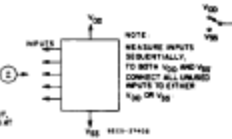

Fig. 20—Input leakage current test circuit.

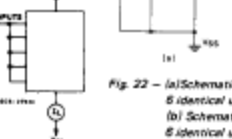

Fig. 21—Quiescent device current test circuit.

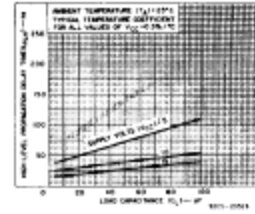

Fig. 12—Typical low-to-high level propagation delay time vs.  $C_L$  for CD4049A.

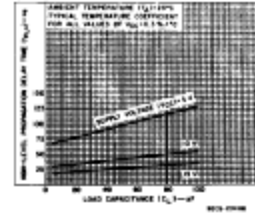

Fig. 13—Typical low-to-high level propagation delay time vs.  $C_L$  for CD4050A.

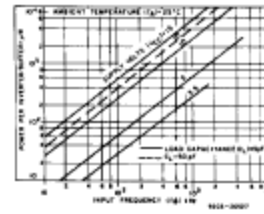

Fig. 16—Typical dissipation characteristics for CD4049A, CD4050A.

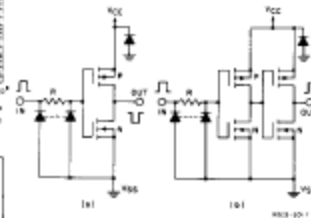

Fig. 22—(a) Schematic diagram of CD4049A, 1 of 8 identical units.  
(b) Schematic diagram of CD4050A, 1 of 8 identical units.

# RC4558 Operational Amplifier



www.fairchildsemi.com

## RC4558 Dual High-Gain Operational Amplifier

### Features

- 2.5 MHz unity gain bandwidth
- Supply voltage  $\pm 22V$  for RM4558 and  $\pm 18V$  for RC/RM4558
- Short-circuit protection
- No frequency compensation required
- No latch-up
- Large common-mode and differential voltage ranges
- Low power consumption
- Parameter tracking over temperature range
- Gain and phase match between amplifiers

### Description

The RC4558 integrated circuit is a dual high-gain operational amplifier internally compensated and constructed on a single silicon IC using an advanced epitaxial process.

Combining the features of the 741 with the close parameter matching and tracking of a dual device on a monolithic chip results in unique performance characteristics. Excellent channel separation allows the use of this dual device in dense single 741 operational amplifier applications. It is especially well suited for applications in differential-in, differential-out as well as in potentiometric amplifiers and where gain and phase matched channels are mandatory.

### Block Diagram

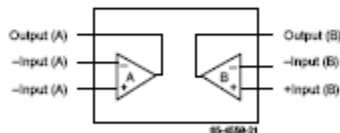

Rev. 1.0.0

**Pin Assignments**

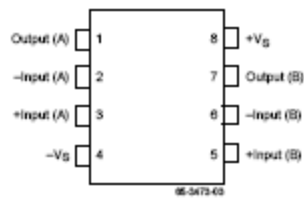
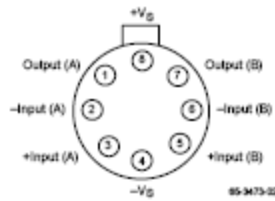

**Absolute Maximum Ratings**  
(beyond which the device may be damaged)<sup>1</sup>

Parameter		Min	Typ	Max	Units
Supply Voltage	RM4558			±22	V
	RC4558			±18	V
Input Voltage <sup>2</sup>				±15	V
Differential Input Voltage				30	V
P <sub>oTA</sub> < 50°C	SOIC			300	mW
	PDIP			468	
	CerDIP			633	
	TO-99			658	
Junction Temperature	SOIC, PDIP			125	°C
	CerDIP, TO-99			175	
Operating Temperature	RM4558	-55		125	°C
	RC4558	0		70	
Lead Soldering Temperature	PDIP, CerDIP, TO-99 (60 sec)			300	°C
	SOIC (10 sec)			260	
Output Short Circuit Duration <sup>3</sup>				Indefinite	

**Notes:**

1. Functional operation under any of these conditions is NOT implied.
2. For supply voltages less than ±15V, the absolute maximum input voltage is equal to the supply voltage.
3. Short circuit may be to ground on one op amp only. Rating applies to +75°C ambient temperature.

**Matching Characteristics**

(V<sub>S</sub> = ±15V, T<sub>A</sub> = +25°C unless otherwise specified)

Parameter	Test Conditions	Typ	Units
Voltage Gain	R <sub>L</sub> ≥ 2 kΩ	±1.0	dB
Input Bias Current	R <sub>L</sub> ≥ 2 kΩ	±15	nA
Input Offset Current	R <sub>L</sub> ≥ 2 kΩ	±7.5	nA

### Electrical Characteristics

( $V_S = \pm 15V$  and  $T_A = +25^\circ C$  unless otherwise specified)

Parameters	Test Conditions	RM4558			RC4558			Units
		Min	Typ	Max	Min	Typ	Max	
Input Offset Voltage	$R_S \leq 10k\Omega$		1.0	5.0		2.0	6.0	mV
Input Offset Current			5.0	200		5.0	200	nA
Input Bias Current			40	500		40	500	nA
Input Resistance		0.3	1.0		0.3	1.0		M $\Omega$
Large Signal Voltage Gain	$R_L \geq 2k\Omega$ , $V_{OUT} = \pm 10V$	50	300		20	300		V/mV
Output Voltage Swing	$R_L \geq 10k\Omega$	$\pm 12$	$\pm 14$		$\pm 12$	$\pm 14$		V
	$R_L \geq 2k\Omega$	$\pm 10$	$\pm 13$		$\pm 10$	$\pm 13$		V
Input Voltage Range		$\pm 12$	$\pm 13$		$\pm 12$	$\pm 13$		V
Common Mode Rejection Ratio	$R_S \leq 10k\Omega$	70	100		70	100		dB
Power Supply Rejection Ratio	$R_S \leq 10k\Omega$	76	100		76	100		dB
Power Consumption	$R_L = \infty$		100	170		100	170	mW
Transient Response	$V_{IN} = 20\text{ mV}$							
Rise Time	$R_L = 2k\Omega$		0.3			0.3		$\mu\text{s}$
Overshoot	$C_L \leq 100\text{pF}$		35			35		%
Slew Rate	$R_L \geq 2k\Omega$		0.8			0.8		V/ $\mu\text{s}$
Channel Separation	$F = 10\text{kHz}$ , $R_S = 1k\Omega$		90			90		dB
Unity Gain Bandwidth (Gain = 1)		2.5	3.0		2.0	3.0		MHz

The following specifications apply for RM =  $-55^\circ C \leq T_A \leq +125^\circ C$ , RC =  $0^\circ \leq T_A \leq +70^\circ C$

Parameters	Test Conditions	RM4558			RC4558			Units
		Min	Typ	Max	Min	Typ	Max	
Input Offset Voltage	$R_S \leq 10k\Omega$			6.0			7.5	mV
Input Offset Current				500			300	nA
Input bias Current				1500			800	nA
Large Signal Voltage Gain	$R_L \geq 2k\Omega$ , $V_{OUT} = \pm 10$	25			15			V/mV
Output Voltage Swing	$R_L \geq 2k\Omega$	$\pm 10$			$\pm 10$			V
Power Consumption	$R_L = \infty$		120	200		120	200	mW



Typical Performance Characteristics

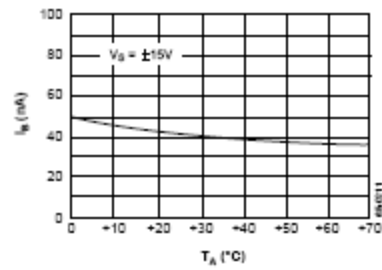

Figure 1. Input Bias Current vs. Temperature

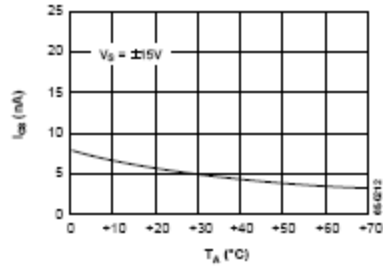

Figure 2. Input Offset Current vs. Temperature

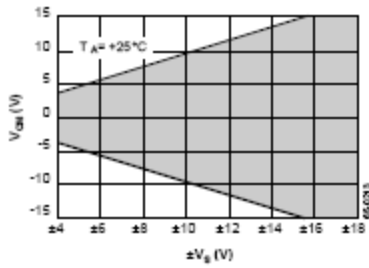

Figure 3. Input Common Mode Voltage Range vs. Supply Voltage

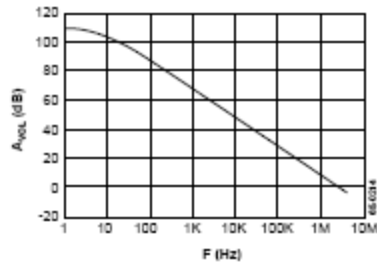

Figure 4. Open Loop Voltage Gain vs. Frequency

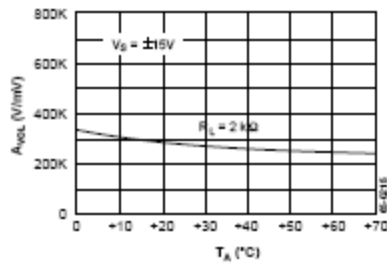

Figure 5. Open Loop Voltage Gain vs. Temperature

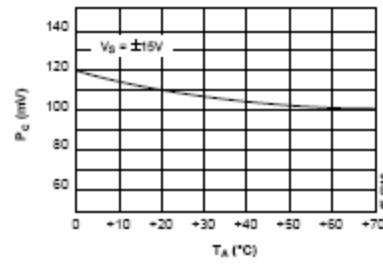

Figure 6. Power Consumption vs. Temperature

Typical Performance Characteristics (continued)

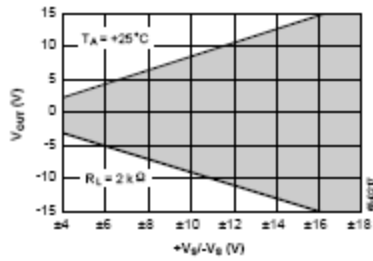

Figure 7. Output Voltage Swing vs. Supply Voltage

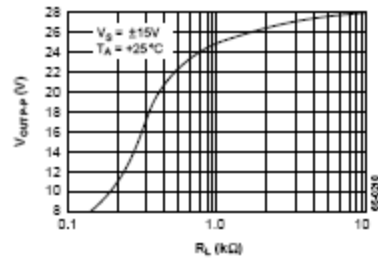

Figure 8. Output Voltage Swing vs. Load Resistance

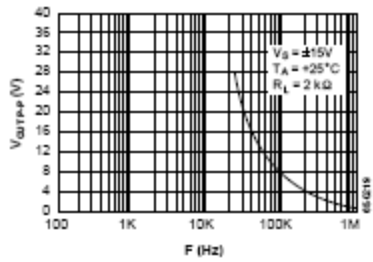

Figure 9. Output Voltage Swing vs. Frequency

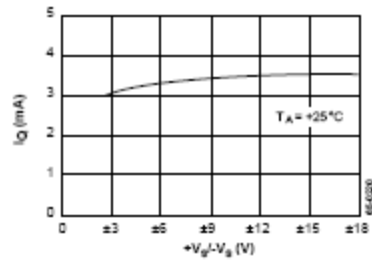

Figure 10. Quiescent Current vs. Supply Voltage

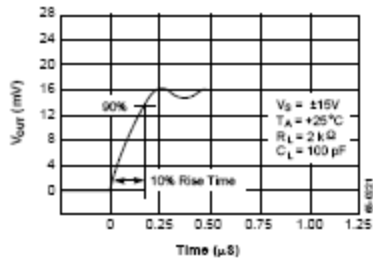

Figure 11. Transient Response Output Voltage vs. Time

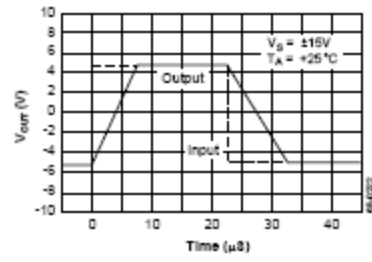

Figure 12. Follower Large Signal Pulse Response Output Voltage vs. Time

Typical Performance Characteristics (continued)

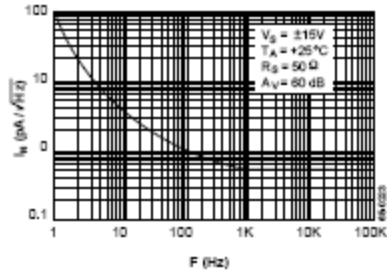

Figure 13. Input Noise Current Density vs. Frequency

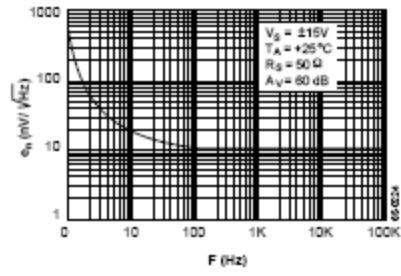

Figure 14. Input Noise Voltage Density vs. Frequency

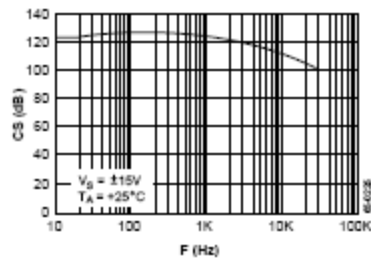

Figure 15. Channel Separation vs. Frequency

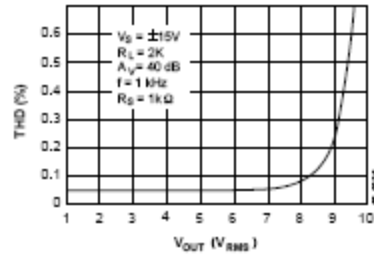

Figure 16. Total Harmonic Distortion vs. Output Voltage

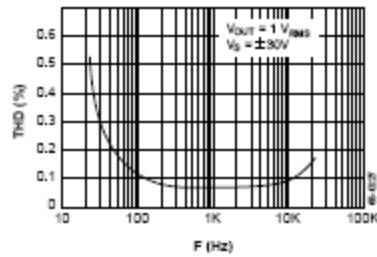

Figure 17. Distortion vs. Frequency

## BA3812L 5-Band Equalizer Chip

### Audio ICs

# 5-channel graphic equalizer

## BA3812L

The BA3812L is a five-point graphic equalizer that has all the required functions integrated onto one IC. The IC is comprised of the five tone control circuits and input and output buffer amplifiers.

The BA3812L features low distortion, low noise, and wide dynamic range, and is an ideal choice for HI-FI stereo applications. It also has a wide operating voltage range (3.5V to 16V), which means that it can be adapted for use with most types of stereo equipment.

The five center frequencies are independently set using external capacitors, and as the output stage buffer amplifier and tone control section are independent circuits, fine control over a part of the frequency bandwidth is possible. By using two BA3812Ls, it is possible to construct a 10-point graphic equalizer.

The amount of boost and cut can be set by external components.

#### ●Applications

Radio cassette players, home stereo systems and car stereo systems.

#### ●Features

- 1) Minimizes the number of components required to build a graphic equalizer.
- 2) Low distortion and low noise.
- 3) Wide operating power supply voltage range (3.5V to 16V).
- 4) Low current dissipation (5 mA).
- 5) Wide dynamic range ( $V_{OL} = 2.1V_{rms}/V_{CC} = 8V$ ).
- 6) Built-in input and output buffer amplifiers.

#### ●Absolute maximum ratings (Ta = 25°C)

Parameter	Symbol	Limits	Unit
Power supply voltage	V <sub>CC</sub>	16	V
Power dissipation	P <sub>d</sub>	550 *	mW
Operating temperature	T <sub>opr</sub>	-25~+75	°C
Storage temperature	T <sub>stg</sub>	-55~+125	°C

\* Reduced by 5.5 mW for each increase in Ta of 1°C over 25°C.

#### ●Recommended operating conditions (Ta = 25°C)

Parameter	Symbol	Min.	Typ.	Max.	Unit
Power supply voltage	V <sub>CC</sub>	3.5	8	16	V

## ● Block diagram

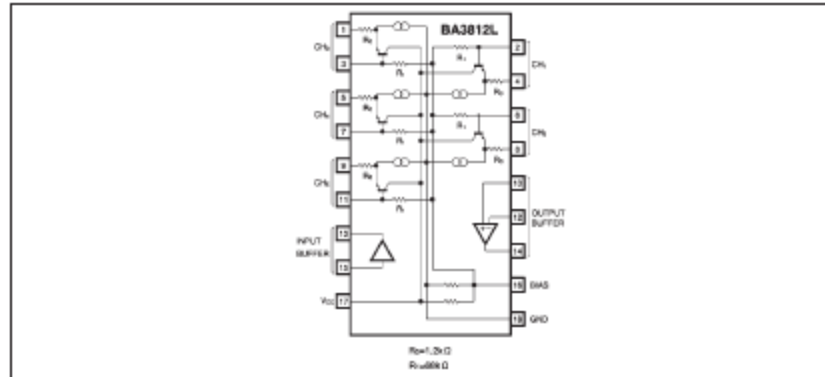
● Electrical characteristics (unless otherwise noted,  $T_a = 25^\circ\text{C}$ ,  $V_{CC} = 6\text{V}$ , and  $f_{in} = 1\text{kHz}$ )

Parameter	Symbol	Min.	Typ.	Max.	Unit	Conditions
Quiescent current	$I_Q$	2.5	5.0	8.0	mA	—
Maximum output voltage	$V_{OM}$	1.5	2.1	—	V	THD=1%
Total harmonic distortion	THD	—	0.01	0.1	%	$V_{out}=120\text{mV}$ , $f=1\text{kHz}$
Output noise voltage	$V_{NO}$	—	5	20	$\mu\text{V}$	$R_N=10\text{k}\Omega$
Input / output gain	$G_V$	-2.5	-0.5	1.5	dB	Overall input/output gain when all flat $V_{IN}=200\text{mV}$
Control range	CR	$\pm 10$	$\pm 12.0$	$\pm 14$	dB	$V_{IN}=200\text{mV}$

●Measurement circuit

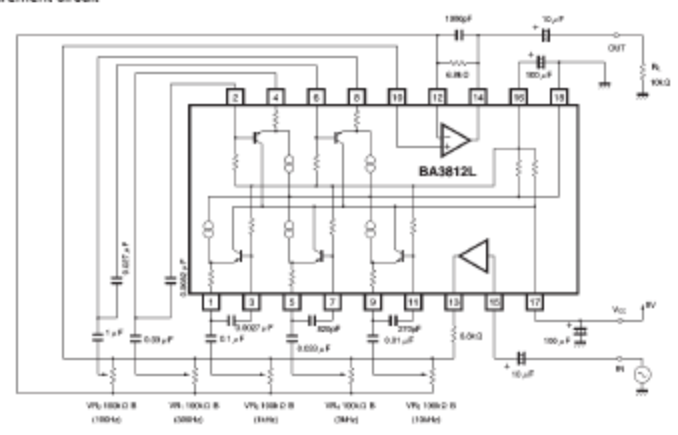

Fig. 1

●Application example

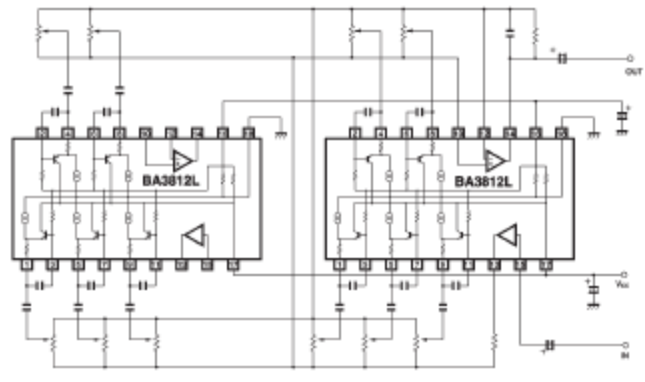

Fig. 2 10-point single channel graphic equalizer circuit

By using more than one IC the following applications are also possible:

(1) 10-point single-channel graphic equalizer

As shown in Fig. 2, with two ICs it is possible to construct a 10-point single-channel graphic equalizer,

(2) 7-point stereo graphic equalizer

As shown in Fig. 3, with three ICs it is possible to construct a 7-point stereo graphic equalizer. Two BA3812L ICs are used to construct a 5-point stereo graphic equalizer, and two of the active inductor circuits from a third BA3812L are added to each.

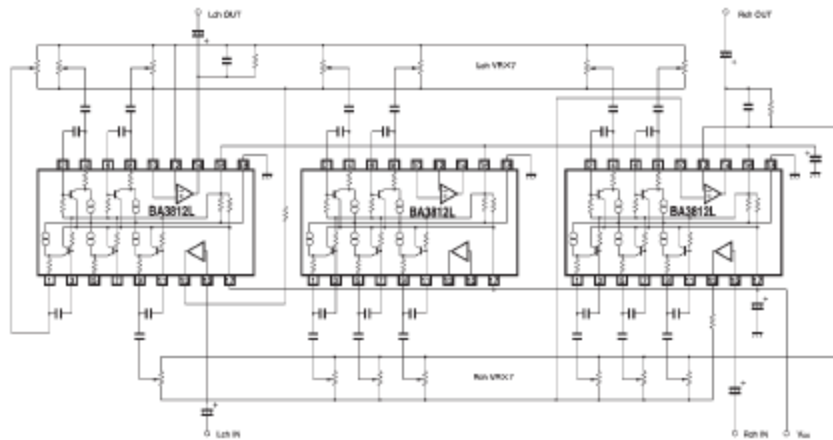

Fig. 3 7-point stereo graphic equalizer circuit

74HC08N Quad AND

**INTEGRATED CIRCUITS**

**DATA SHEET**

**74HC08; 74HCT08**  
**Quad 2-input AND gate**

Product specification  
Supersedes data of 1990 Dec 01

2003 Jul 25

Philips  
Semiconductors



**PHILIPS**



## Quad 2-input AND gate

74HC08; 74HCT08

## FEATURES

- Complies with JEDEC standard no. 8-1A
- ESD protection:  
HBM EIA/JESD22-A114-A exceeds 2000 V  
MM EIA/JESD22-A115-A exceeds 200 V.
- Specified from  $-40$  to  $+85$  °C and  $-40$  to  $+125$  °C.

## DESCRIPTION

The 74HC/HCT08 are high-speed Si-gate CMOS devices and are pin compatible with low power Schottky TTL (LS TTL). They are specified in compliance with JEDEC standard no. 7A. The 74HC/HCT08 provide the 2-input AND function.

## QUICK REFERENCE DATA

GND = 0 V;  $T_{amb} = 25$  °C;  $t_r = t_f = 6$  ns.

SYMBOL	PARAMETER	CONDITIONS	TYPICAL		UNIT
			74HC08	74HCT08	
$t_{PHL}/t_{PLH}$	propagation delay nA, nB to nY	$C_L = 15$ pF; $V_{CC} = 5$ V	7	11	ns
$C_i$	input capacitance		3.5	3.5	pF
$C_{PD}$	power dissipation capacitance per gate	notes 1 and 2	10	20	pF

## Notes

- $C_{PD}$  is used to determine the dynamic power dissipation ( $P_D$  in  $\mu$ W).

$$P_D = C_{PD} \times V_{CC}^2 \times f_i \times N + \sum(C_L \times V_{CC}^2 \times f_o)$$

where:

$f_i$  = input frequency in MHz;

$f_o$  = output frequency in MHz;

$C_L$  = output load capacitance in pF;

$V_{CC}$  = supply voltage in Volts;

$N$  = total load switching outputs;

$\sum(C_L \times V_{CC}^2 \times f_o)$  = sum of the outputs.

- For 74HC08: the condition is  $V_i = \text{GND to } V_{CC}$ .

For 74HCT08: the condition is  $V_i = \text{GND to } V_{CC} - 1.5$  V.

## FUNCTION TABLE

INPUT		OUTPUT
nA	nB	nY
L	L	L
L	H	L
H	L	L
H	H	H

## Note

- H = HIGH voltage level;  
L = LOW voltage level.

## Quad 2-input AND gate

74HC08; 74HCT08

## ORDERING INFORMATION

TYPE NUMBER	PACKAGE				
	TEMPERATURE RANGE	PINS	PACKAGE	MATERIAL	CODE
74HC08N	-40 to +125 °C	14	DIP14	plastic	SOT27-1
74HCT08N	-40 to +125 °C	14	DIP14	plastic	SOT27-1
74HC08D	-40 to +125 °C	14	SO14	plastic	SOT108-1
74HCT08D	-40 to +125 °C	14	SO14	plastic	SOT108-1
74HC08DB	-40 to +125 °C	14	SSOP14	plastic	SOT337-1
74HCT08DB	-40 to +125 °C	14	SSOP14	plastic	SOT337-1
74HC08PW	-40 to +125 °C	14	TSSOP14	plastic	SOT402-1
74HCT08PW	-40 to +125 °C	14	TSSOP14	plastic	SOT402-1
74HC08BQ	-40 to +125 °C	14	DHVQFN14	plastic	SOT762-1
74HCT08BQ	-40 to +125 °C	14	DHVQFN14	plastic	SOT762-1

## PINNING

PIN	SYMBOL	DESCRIPTION
1	1A	data input
2	1B	data input
3	1Y	data output
4	2A	data input
5	2B	data input
6	2Y	data output
7	GND	ground (0 V)
8	3Y	data output
9	3A	data input
10	3B	data input
11	4Y	data output
12	4A	data input
13	4B	data input
14	V <sub>CC</sub>	supply voltage

Quad 2-input AND gate

74HC08; 74HCT08

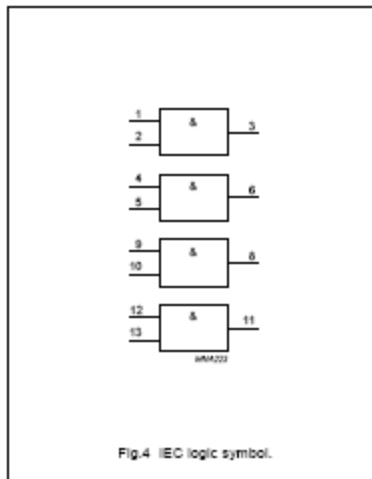
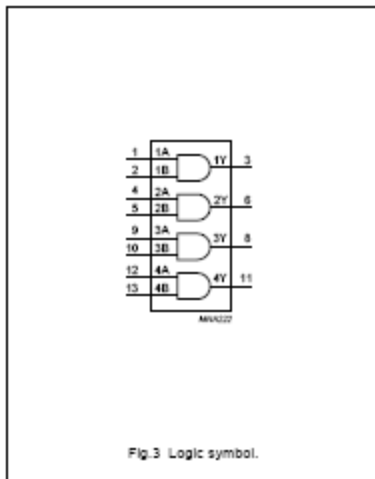
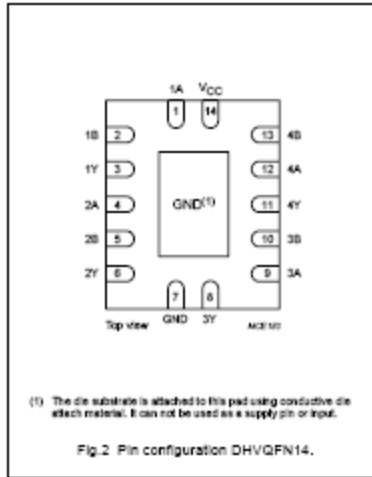
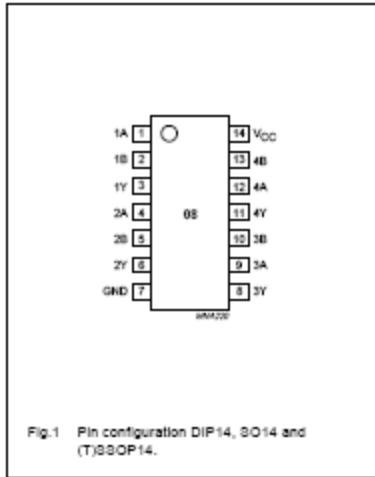

## Quad 2-input AND gate

74HC08; 74HCT08

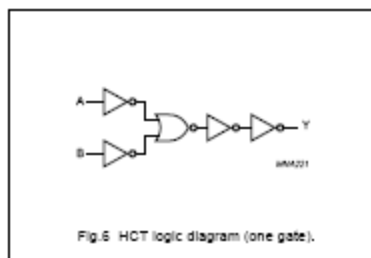
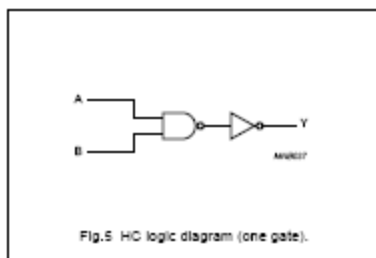

## RECOMMENDED OPERATING CONDITIONS

SYMBOL	PARAMETER	CONDITIONS	74HC08			74HCT08			UNIT
			MIN.	TYP.	MAX.	MIN.	TYP.	MAX.	
$V_{CC}$	supply voltage		2.0	5.0	6.0	4.5	5.0	5.5	V
$V_I$	input voltage		0	–	$V_{CC}$	0	–	$V_{CC}$	V
$V_O$	output voltage		0	–	$V_{CC}$	0	–	$V_{CC}$	V
$T_{amb}$	ambient temperature	see DC and AC characteristics per device	–40	+25	+125	–40	+25	+125	°C
$t_r, t_f$	input rise and fall times	$V_{CC} = 2.0$ V	–	–	1000	–	–	–	ns
		$V_{CC} = 4.5$ V	–	6.0	500	–	6.0	500	ns
		$V_{CC} = 6.0$ V	–	–	400	–	–	–	ns

## LIMITING VALUES

In accordance with the Absolute Maximum Rating System (IEC 60134); voltages are referenced to GND (ground = 0 V).

SYMBOL	PARAMETER	CONDITIONS	MIN.	MAX.	UNIT	
$V_{CC}$	supply voltage		–0.5	+7.0	V	
$I_{IK}$	input diode current	$V_I < -0.5$ V or $V_I > V_{CC} + 0.5$ V	–	±20	mA	
$I_{OK}$	output diode current	$V_O < -0.5$ V or $V_O > V_{CC} + 0.5$ V	–	±20	mA	
$I_O$	output source or sink current	$-0.5$ V < $V_O < V_{CC} + 0.5$ V	–	±25	mA	
$I_{CC}, I_{GND}$	$V_{CC}$ or GND current		–	±50	mA	
$T_{stg}$	storage temperature		–65	+150	°C	
$P_{tot}$	power dissipation	DIP14 package	$T_{amb} = -40$ to $+125$ °C; note 1	–	750	mW
		other packages	$T_{amb} = -40$ to $+125$ °C; note 2	–	500	mW

## Notes

- For DIP14 packages: above 70 °C derate linearly with 12 mW/K.
- For SO14 packages: above 70 °C derate linearly with 8 mW/K.  
For SSOP14 and TSSOP14 packages: above 60 °C derate linearly with 5.5 mW/K.  
For DHVQFN14 packages: above 60 °C derate linearly with 4.5 mW/K.

## Quad 2-input AND gate

74HC08; 74HCT08

## DC CHARACTERISTICS

## Family 74HC08

At recommended operating conditions; voltages are referenced to GND (ground = 0 V).

SYMBOL	PARAMETER	TEST CONDITIONS		MIN.	TYP.	MAX.	UNIT
		OTHER	V <sub>CC</sub> (V)				
T <sub>amb</sub> = 25 °C							
V <sub>IH</sub>	HIGH-level input voltage		2.0	1.5	1.2	—	V
			4.5	3.15	2.4	—	V
			6.0	4.2	3.2	—	V
V <sub>IL</sub>	LOW-level input voltage		2.0	—	0.8	0.5	V
			4.5	—	2.1	1.35	V
			6.0	—	2.8	1.8	V
V <sub>OH</sub>	HIGH-level output voltage	V <sub>I</sub> = V <sub>IH</sub> or V <sub>IL</sub>	2.0	1.9	2.0	—	V
		I <sub>O</sub> = -20 µA	4.5	4.4	4.5	—	V
		I <sub>O</sub> = -4.0 mA	4.5	3.98	4.32	—	V
		I <sub>O</sub> = -20 µA	6.0	5.9	6.0	—	V
		I <sub>O</sub> = -5.2 mA	6.0	5.48	5.81	—	V
V <sub>OL</sub>	LOW-level output voltage	V <sub>I</sub> = V <sub>IH</sub> or V <sub>IL</sub>	2.0	—	0	0.1	V
		I <sub>O</sub> = 20 µA	4.5	—	0	0.1	V
		I <sub>O</sub> = 4.0 mA	4.5	—	0.15	0.25	V
		I <sub>O</sub> = 20 µA	6.0	—	0	0.1	V
		I <sub>O</sub> = 5.2 mA	6.0	—	0.16	0.25	V
I <sub>I</sub>	input leakage current	V <sub>I</sub> = V <sub>CC</sub> or GND	6.0	—	0.1	±0.1	µA
I <sub>OZ</sub>	3-state output OFF current	V <sub>I</sub> = V <sub>IH</sub> or V <sub>IL</sub> ; V <sub>O</sub> = V <sub>CC</sub> or GND	6.0	—	—	±0.5	µA
I <sub>CC</sub>	quiescent supply current	V <sub>I</sub> = V <sub>CC</sub> or GND; I <sub>O</sub> = 0	6.0	—	—	2	µA

## Quad 2-input AND gate

## 74HC08; 74HCT08

SYMBOL	PARAMETER	TEST CONDITIONS		MIN.	TYP.	MAX.	UNIT
		OTHER	V <sub>CC</sub> (V)				
T <sub>amb</sub> = -40 to +86 °C							
V <sub>IH</sub>	HIGH-level input voltage		2.0	1.5	–	–	V
			4.5	3.15	–	–	V
			6.0	4.2	–	–	V
V <sub>IL</sub>	LOW-level input voltage		2.0	–	–	0.5	V
			4.5	–	–	1.35	V
			6.0	–	–	1.8	V
V <sub>OHI</sub>	HIGH-level output voltage	V <sub>I</sub> = V <sub>IH</sub> or V <sub>IL</sub> I <sub>O</sub> = -20 µA I <sub>O</sub> = -20 µA I <sub>O</sub> = -4.0 mA I <sub>O</sub> = -20 µA I <sub>O</sub> = -5.2 mA	2.0	1.9	–	–	V
			4.5	4.4	–	–	V
			4.5	3.84	–	–	V
			6.0	5.9	–	–	V
			6.0	5.34	–	–	V
V <sub>OOL</sub>	LOW-level output voltage	V <sub>I</sub> = V <sub>IH</sub> or V <sub>IL</sub> I <sub>O</sub> = 20 µA I <sub>O</sub> = 20 µA I <sub>O</sub> = 4.0 mA I <sub>O</sub> = 20 µA I <sub>O</sub> = 5.2 mA	2.0	–	–	0.1	V
			4.5	–	–	0.1	V
			4.5	–	–	0.33	V
			6.0	–	–	0.1	V
			6.0	–	–	0.33	V
I <sub>I1</sub>	Input leakage current	V <sub>I</sub> = V <sub>CC</sub> or GND	6.0	–	–	±1.0	µA
I <sub>OZ</sub>	3-state output OFF current	V <sub>I</sub> = V <sub>IH</sub> or V <sub>IL</sub> ; V <sub>O</sub> = V <sub>CC</sub> or GND	6.0	–	–	±5.0	µA
I <sub>CC</sub>	quiescent supply current	V <sub>I</sub> = V <sub>CC</sub> or GND; I <sub>O</sub> = 0	6.0	–	–	20	µA

## Quad 2-input AND gate

74HC08; 74HCT08

SYMBOL	PARAMETER	TEST CONDITIONS		MIN.	TYP.	MAX.	UNIT
		OTHER	V <sub>CC</sub> (V)				
T <sub>amb</sub> = -40 to +126 °C							
V <sub>IH</sub>	HIGH-level input voltage		2.0	1.5	–	–	V
			4.5	3.15	–	–	V
			6.0	4.2	–	–	V
V <sub>IL</sub>	LOW-level input voltage		2.0	–	–	0.5	V
			4.5	–	–	1.35	V
			6.0	–	–	1.8	V
V <sub>OHI</sub>	HIGH-level output voltage	V <sub>I</sub> = V <sub>IH</sub> or V <sub>IL</sub>					
		I <sub>O</sub> = -20 µA	2.0	1.9	–	–	V
		I <sub>O</sub> = -20 µA	4.5	4.4	–	–	V
		I <sub>O</sub> = -4.0 mA	4.5	3.7	–	–	V
		I <sub>O</sub> = -20 µA	6.0	5.9	–	–	V
V <sub>OL</sub>	LOW-level output voltage	V <sub>I</sub> = V <sub>IH</sub> or V <sub>IL</sub>					
		I <sub>O</sub> = 20 µA	2.0	–	–	0.1	V
		I <sub>O</sub> = 20 µA	4.5	–	–	0.1	V
		I <sub>O</sub> = 4.0 mA	4.5	–	–	0.4	V
		I <sub>O</sub> = 20 µA	6.0	–	–	0.1	V
I <sub>I</sub>	input leakage current	V <sub>I</sub> = V <sub>CC</sub> or GND	6.0	–	–	±1.0	µA
		V <sub>I</sub> = V <sub>IH</sub> or V <sub>IL</sub> ; V <sub>O</sub> = V <sub>CC</sub> or GND	6.0	–	–	±10.0	µA
I <sub>CC</sub>	quiescent supply current	V <sub>I</sub> = V <sub>CC</sub> or GND; I <sub>O</sub> = 0	6.0	–	–	40	µA

## Quad 2-input AND gate

74HC08; 74HCT08

## Family 74HCT08

At recommended operating conditions; voltages are referenced to GND (ground = 0).

SYMBOL	PARAMETER	TEST CONDITIONS		MIN.	TYP.	MAX.	UNIT
		OTHER	V <sub>CC</sub> (V)				
T <sub>amb</sub> = 25 °C							
V <sub>HI</sub>	HIGH-level input voltage		4.5 to 5.5	2.0	1.6	–	V
V <sub>IL</sub>	LOW-level input voltage		4.5 to 5.5	–	1.2	0.8	V
V <sub>OHI</sub>	HIGH-level output voltage	V <sub>I</sub> = V <sub>HI</sub> or V <sub>IL</sub> I <sub>O</sub> = –20 µA I <sub>O</sub> = –4.0 mA	4.5	4.4	4.5	–	V
			4.5	3.84	4.32	–	V
V <sub>OOL</sub>	LOW-level output voltage	V <sub>I</sub> = V <sub>HI</sub> or V <sub>IL</sub> I <sub>O</sub> = 20 µA I <sub>O</sub> = 4.0 mA	4.5	–	0	0.1	V
			4.5	–	0.15	0.26	V
I <sub>I1</sub>	input leakage current	V <sub>I</sub> = V <sub>CC</sub> or GND	5.5	–	–	±0.1	µA
I <sub>OZ</sub>	3-state output OFF current	V <sub>I</sub> = V <sub>HI</sub> or V <sub>IL</sub> ; V <sub>O</sub> = V <sub>CC</sub> or GND; I <sub>O</sub> = 0	5.5	–	–	±0.5	µA
I <sub>CC</sub>	quiescent supply current	V <sub>I</sub> = V <sub>CC</sub> or GND; I <sub>O</sub> = 0	5.5	–	–	2	µA
ΔI <sub>CC</sub>	additional supply current per input	V <sub>I</sub> = V <sub>CC</sub> – 2.1 V; I <sub>O</sub> = 0	4.5 to 5.5	–	60	216	µA
T <sub>amb</sub> = –40 to +86 °C							
V <sub>HI</sub>	HIGH-level input voltage		4.5 to 5.5	2.0	–	–	V
V <sub>IL</sub>	LOW-level input voltage		4.5 to 5.5	–	–	0.8	V
V <sub>OHI</sub>	HIGH-level output voltage	V <sub>I</sub> = V <sub>HI</sub> or V <sub>IL</sub> I <sub>O</sub> = –20 µA I <sub>O</sub> = –4.0 mA	4.5	4.4	–	–	V
			4.5	3.84	–	–	V
V <sub>OOL</sub>	LOW-level output voltage	V <sub>I</sub> = V <sub>HI</sub> or V <sub>IL</sub> I <sub>O</sub> = 20 µA I <sub>O</sub> = 4.0 mA	4.5	–	–	0.1	V
			4.5	–	–	0.33	V
I <sub>I1</sub>	input leakage current	V <sub>I</sub> = V <sub>CC</sub> or GND	5.5	–	–	±1.0	µA
I <sub>OZ</sub>	3-state output OFF current	V <sub>I</sub> = V <sub>HI</sub> or V <sub>IL</sub> ; V <sub>O</sub> = V <sub>CC</sub> or GND; I <sub>O</sub> = 0	5.5	–	–	±5.0	µA
I <sub>CC</sub>	quiescent supply current	V <sub>I</sub> = V <sub>CC</sub> or GND; I <sub>O</sub> = 0	5.5	–	–	20	µA
ΔI <sub>CC</sub>	additional supply current per input	V <sub>I</sub> = V <sub>CC</sub> – 2.1 V; I <sub>O</sub> = 0	4.5 to 5.5	–	–	270	µA



## Quad 2-input AND gate

74HC08; 74HCT08

SYMBOL	PARAMETER	TEST CONDITIONS		MIN.	TYP.	MAX.	UNIT
		OTHER	V <sub>CC</sub> (V)				
T <sub>amb</sub> = -40 to +125 °C							
V <sub>IH</sub>	HIGH-level input voltage		4.5 to 5.5	2.0	–	–	V
V <sub>IL</sub>	LOW-level input voltage		4.5 to 5.5	–	–	0.8	V
V <sub>OH</sub>	HIGH-level output voltage	V <sub>I</sub> = V <sub>IH</sub> or V <sub>IL</sub> I <sub>O</sub> = -20 µA	4.5	4.4	–	–	V
		I <sub>O</sub> = -4.0 mA	4.5	3.7	–	–	V
V <sub>OL</sub>	LOW-level output voltage	V <sub>I</sub> = V <sub>IH</sub> or V <sub>IL</sub> I <sub>O</sub> = 20 µA	4.5	–	–	0.1	V
		I <sub>O</sub> = 4.0 mA	4.5	–	–	0.4	V
I <sub>I</sub>	input leakage current	V <sub>I</sub> = V <sub>CC</sub> or GND	5.5	–	–	±1.0	µA
I <sub>OZ</sub>	3-state output OFF current	V <sub>I</sub> = V <sub>IH</sub> or V <sub>IL</sub> ; V <sub>O</sub> = V <sub>CC</sub> or GND; I <sub>O</sub> = 0	5.5	–	–	±10	µA
I <sub>CC</sub>	quiescent supply current	V <sub>I</sub> = V <sub>CC</sub> or GND; I <sub>O</sub> = 0	5.5	–	–	40	µA
ΔI <sub>CC</sub>	additional supply current per input	V <sub>I</sub> = V <sub>CC</sub> - 2.1 V; I <sub>O</sub> = 0	4.5 to 5.5	–	–	254	µA

## Quad 2-input AND gate

74HC08; 74HCT08

## AC CHARACTERISTICS

Family 74HC08

GND = 0 V;  $t_r = t_f = 6$  ns;  $C_L = 50$  pF.

SYMBOL	PARAMETER	TEST CONDITIONS		MIN.	TYP.	MAX.	UNIT
		WAVEFORMS	V <sub>CC</sub> (V)				
T <sub>amb</sub> = 25 °C							
t <sub>PHL</sub> /t <sub>PLH</sub>	propagation delay nA, nB to nY	see Figs 7 and 8	2.0	–	25	90	ns
			4.5	–	9	18	ns
			6.0	–	7	15	ns
t <sub>THL</sub> /t <sub>TLH</sub>	output transition time	see Figs 7 and 8	2.0	–	19	75	ns
			4.5	–	7	15	ns
			6.0	–	6	13	ns
T <sub>amb</sub> = –40 to +86 °C							
t <sub>PHL</sub> /t <sub>PLH</sub>	propagation delay nA, nB to nY	see Figs 7 and 8	2.0	–	–	115	ns
			4.5	–	–	23	ns
			6.0	–	–	20	ns
t <sub>THL</sub> /t <sub>TLH</sub>	output transition time	see Figs 7 and 8	2.0	–	–	95	ns
			4.5	–	–	19	ns
			6.0	–	–	16	ns
T <sub>amb</sub> = –40 to +126 °C							
t <sub>PHL</sub> /t <sub>PLH</sub>	propagation delay nA, nB to nY	see Figs 7 and 8	2.0	–	–	135	ns
			4.5	–	–	27	ns
			6.0	–	–	23	ns
t <sub>THL</sub> /t <sub>TLH</sub>	output transition time	see Figs 7 and 8	2.0	–	–	110	ns
			4.5	–	–	22	ns
			6.0	–	–	19	ns

## Quad 2-input AND gate

74HC08; 74HCT08

## Family 74HCT08

GND = 0 V;  $t_r = t_f = 6$  ns;  $C_L = 50$  pF

SYMBOL	PARAMETER	TEST CONDITIONS		MIN.	TYP.	MAX.	UNIT
		WAVEFORMS	$V_{CC}$ (V)				
$T_{amb} = 25$ °C							
$t_{PHL}/t_{PLH}$	propagation delay nA, nB to nY	see Figs 7 and 8	4.5	–	14	24	ns
$t_{THL}/t_{TLH}$	output transition time	see Figs 7 and 8	4.5	–	7	15	ns
$T_{amb} = -40$ to $+85$ °C							
$t_{PHL}/t_{PLH}$	propagation delay nA, nB to nY	see Figs 7 and 8	4.5	–	–	30	ns
$t_{THL}/t_{TLH}$	output transition time	see Figs 7 and 8	4.5	–	–	19	ns
$T_{amb} = -40$ to $+125$ °C							
$t_{PHL}/t_{PLH}$	propagation delay nA, nB to nY	see Figs 7 and 8	4.5	–	–	36	ns
$t_{THL}/t_{TLH}$	output transition time	see Figs 7 and 8	4.5	–	–	22	ns

## AC WAVEFORMS

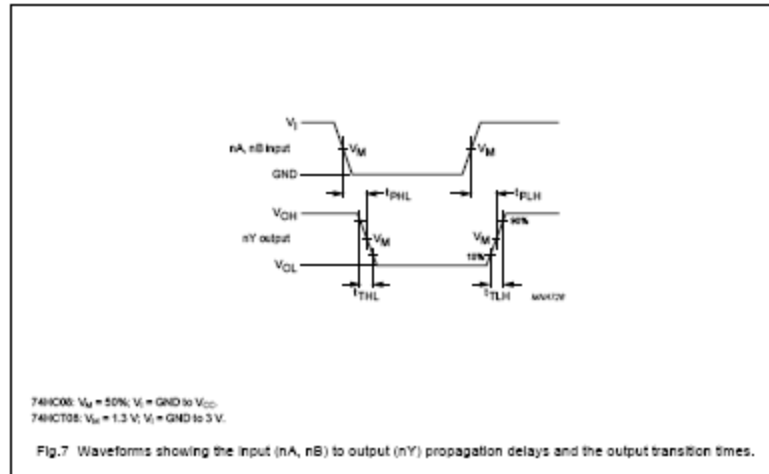

74HC04N Quad Inverter

**INTEGRATED CIRCUITS**

**DATA SHEET**

**74HC04; 74HCT04**  
**Hex inverter**

Product specification  
Supersedes data of 1993 Sep 01

2003 Jul 23

Philips  
Semiconductors



**PHILIPS**

Hex inverter

74HC04; 74HCT04

FEATURES

- Complies with JEDEC standard no. 8-1A
- ESD protection:  
HBM EIA/JESD22-A114-A exceeds 2000 V  
MM EIA/JESD22-A115-A exceeds 200 V.
- Specified from -40 to +85 °C and -40 to +125 °C.

DESCRIPTION

The 74HC/HCT04 are high-speed 3I-gate CMOS devices and are pin compatible with low power Schottky TTL (LS TTL). They are specified in compliance with JEDEC standard no. 7A. The 74HC/HCT04 provide six inverting buffers.

QUICK REFERENCE DATA

GND = 0 V; T<sub>amb</sub> = 25 °C; t<sub>r</sub> = t<sub>f</sub> ≤ 6.0 ns.

SYMBOL	PARAMETER	CONDITIONS	TYPICAL		UNIT
			HC04	HCT04	
t <sub>PHL</sub> /t <sub>PLH</sub>	propagation delay nA to nY	C <sub>L</sub> = 15 pF; V <sub>CC</sub> = 5 V	7	8	ns
C <sub>I</sub>	input capacitance		3.5	3.5	pF
C <sub>PD</sub>	power dissipation capacitance per gate	notes 1 and 2	21	24	pF

Notes

1. C<sub>PD</sub> is used to determine the dynamic power dissipation (P<sub>D</sub> in μW).  
 $P_D = C_{PD} \times V_{CC}^2 \times f_i \times N + \Sigma(C_L \times V_{CC}^2 \times f_o)$  where:  
 f<sub>i</sub> = input frequency in MHz;  
 f<sub>o</sub> = output frequency in MHz;  
 C<sub>L</sub> = output load capacitance in pF;  
 V<sub>CC</sub> = supply voltage in Volts;  
 N = total load switching outputs;  
 $\Sigma(C_L \times V_{CC}^2 \times f_o)$  = sum of the outputs.
2. For 74HC04: the condition is V<sub>I</sub> = GND to V<sub>CC</sub>.  
 For 74HCT04: the condition is V<sub>I</sub> = GND to V<sub>CC</sub> - 1.5 V.

FUNCTION TABLE

See note 1.

INPUT	OUTPUT
nA	nY
L	H
H	L

Note

1. H = HIGH voltage level;  
L = LOW voltage level.

## Hex inverter

74HC04; 74HCT04

## ORDERING INFORMATION

TYPE NUMBER	PACKAGE				
	TEMPERATURE RANGE	PINS	PACKAGE	MATERIAL	CODE
74HC04N	-40 to +125 °C	14	DIP14	plastic	SOT27-1
74HCT04N	-40 to +125 °C	14	DIP14	plastic	SOT27-1
74HC04D	-40 to +125 °C	14	SO14	plastic	SOT108-1
74HCT04D	-40 to +125 °C	14	SO14	plastic	SOT108-1
74HC04DB	-40 to +125 °C	14	SSOP14	plastic	SOT337-1
74HCT04DB	-40 to +125 °C	14	SSOP14	plastic	SOT337-1
74HC04PW	-40 to +125 °C	14	TSSOP14	plastic	SOT402-1
74HCT04PW	-40 to +125 °C	14	TSSOP14	plastic	SOT402-1
74HC04BQ	-40 to +125 °C	14	DHVQFN14	plastic	SOT762-1
74HCT04BQ	-40 to +125 °C	14	DHVQFN14	plastic	SOT762-1

## PINNING

PIN	SYMBOL	DESCRIPTION
1	1A	data input
2	1Y	data output
3	2A	data input
4	2Y	data output
5	3A	data input
6	3Y	data output
7	GND	ground (0 V)
8	4Y	data output
9	4A	data input
10	5Y	data output
11	5A	data input
12	6Y	data output
13	6A	data input
14	V <sub>CC</sub>	supply voltage

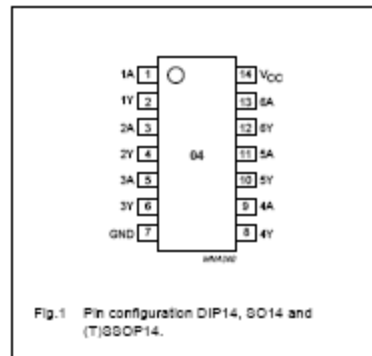

Hex inverter

74HC04; 74HCT04

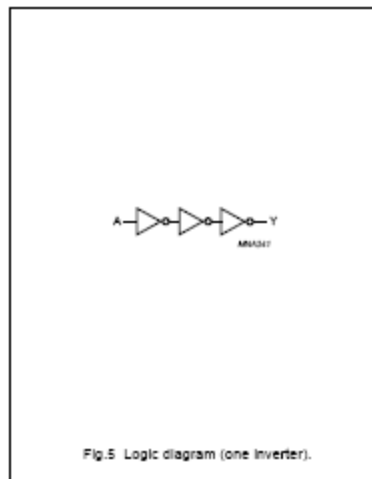
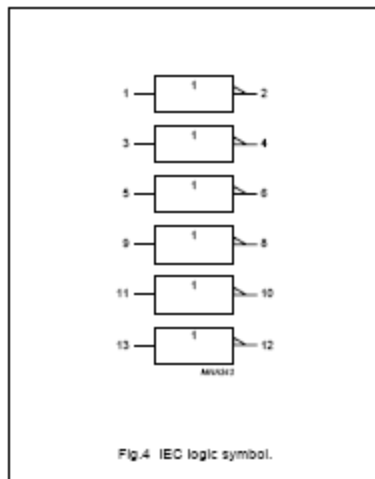
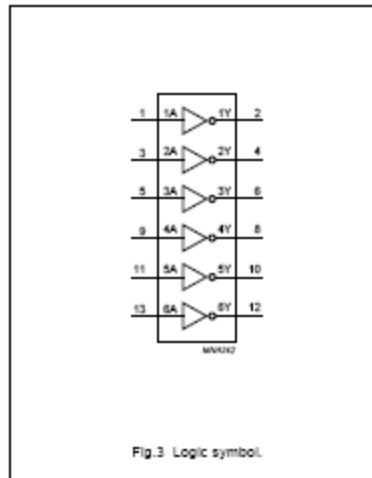
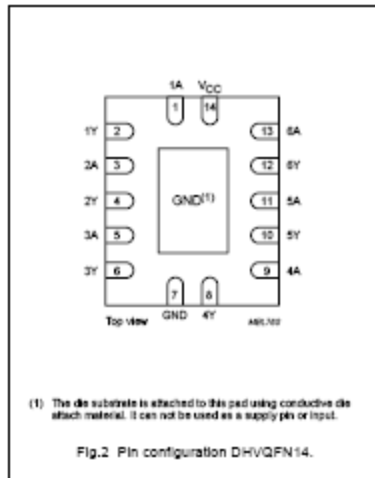

## Hex inverter

74HC04; 74HCT04

## RECOMMENDED OPERATING CONDITIONS

SYMBOL	PARAMETER	CONDITIONS	74HC04			74HCT04			UNIT
			MIN.	TYP.	MAX.	MIN.	TYP.	MAX.	
$V_{CC}$	supply voltage		2.0	5.0	6.0	4.5	5.0	5.5	V
$V_I$	input voltage		0	–	$V_{CC}$	0	–	$V_{CC}$	V
$V_O$	output voltage		0	–	$V_{CC}$	0	–	$V_{CC}$	V
$T_{amb}$	ambient temperature	see DC and AC characteristics per device	–40	+25	+125	–40	+25	+125	°C
$t_r, t_f$	input rise and fall times	$V_{CC} = 2.0$ V	–	–	1000	–	–	–	ns
		$V_{CC} = 4.5$ V	–	–	500	–	–	–	ns
		$V_{CC} = 6.0$ V	–	–	400	–	–	–	ns

## LIMITING VALUES

In accordance with the Absolute Maximum Rating System (IEC 60134); voltages are referenced to GND (ground = 0 V).

SYMBOL	PARAMETER	CONDITIONS	MIN.	MAX.	UNIT
$V_{CC}$	supply voltage		–0.5	+7.0	V
$I_{IK}$	input diode current	$V_I < -0.5$ V or $V_I > V_{CC} + 0.5$ V	–	±20	mA
$I_{OK}$	output diode current	$V_O < -0.5$ V or $V_O > V_{CC} + 0.5$ V	–	±20	mA
$I_O$	output source or sink current	$-0.5$ V $< V_O < V_{CC} + 0.5$ V	–	±25	mA
$I_{CC}, I_{GND}$	$V_{CC}$ or GND current		–	±50	mA
$T_{stg}$	storage temperature		–65	+150	°C
$P_{tot}$	power dissipation		–	–	–
	DIP14 package	$T_{amb} = -40$ to $+125$ °C; note 1	–	750	mW
	other packages	$T_{amb} = -40$ to $+125$ °C; note 2	–	500	mW

## Notes

- For DIP14 packages: above 70 °C derate linearly with 12 mW/K.
- For SO14 packages: above 70 °C derate linearly with 8 mW/K.  
For SSOP14 and TSSOP14 packages: above 60 °C derate linearly with 5.5 mW/K.  
For DHVQFN14 packages: above 60 °C derate linearly with 4.5 mW/K.



## Hex inverter

74HC04; 74HCT04

## DC CHARACTERISTICS

Type 74HC04

At recommended operating conditions; voltages are referenced to GND (ground = 0 V).

SYMBOL	PARAMETER	TEST CONDITIONS		MIN.	TYP.	MAX.	UNIT
		OTHER	V <sub>CC</sub> (V)				
T <sub>amb</sub> = 25 °C							
V <sub>IH</sub>	HIGH-level input voltage		2.0	1.5	1.2	–	V
			4.5	3.15	2.4	–	V
			6.0	4.2	3.2	–	V
V <sub>IL</sub>	LOW-level input voltage		2.0	–	0.8	0.5	V
			4.5	–	2.1	1.35	V
			6.0	–	2.8	1.8	V
V <sub>OH</sub>	HIGH-level output voltage	V <sub>I</sub> = V <sub>IH</sub> or V <sub>IL</sub> I <sub>O</sub> = –20 µA I <sub>O</sub> = –20 µA I <sub>O</sub> = –4.0 mA I <sub>O</sub> = –20 µA I <sub>O</sub> = –5.2 mA	2.0	1.5	2.0	–	V
			4.5	4.4	4.5	–	V
			4.5	3.98	4.32	–	V
			6.0	5.9	6.0	–	V
			6.0	5.48	5.81	–	V
V <sub>OL</sub>	LOW-level output voltage	V <sub>I</sub> = V <sub>IH</sub> or V <sub>IL</sub> I <sub>O</sub> = 20 µA I <sub>O</sub> = 20 µA I <sub>O</sub> = 4.0 mA I <sub>O</sub> = 20 µA I <sub>O</sub> = 5.2 mA	2.0	–	0	0.1	V
			4.5	–	0	0.1	V
			4.5	–	0.15	0.26	V
			6.0	–	0	0.1	V
			6.0	–	0.16	0.26	V
I <sub>I</sub>	input leakage current	V <sub>I</sub> = V <sub>CC</sub> or GND	6.0	–	0.1	±0.1	µA
I <sub>OZ</sub>	3-state output OFF current	V <sub>I</sub> = V <sub>IH</sub> or V <sub>IL</sub> ; V <sub>O</sub> = V <sub>CC</sub> or GND	6.0	–	–	±0.5	µA
I <sub>CC</sub>	quiescent supply current	V <sub>I</sub> = V <sub>CC</sub> or GND; I <sub>O</sub> = 0	6.0	–	–	2	µA

Hex inverter

74HC04; 74HCT04

SYMBOL	PARAMETER	TEST CONDITIONS		MIN.	TYP.	MAX.	UNIT
		OTHER	V <sub>CC</sub> (V)				
T <sub>amb</sub> = -40 to +86 °C							
V <sub>IH</sub>	HIGH-level input voltage		2.0	1.5	–	–	V
			4.5	3.15	–	–	V
			6.0	4.2	–	–	V
V <sub>IL</sub>	LOW-level input voltage		2.0	–	–	0.5	V
			4.5	–	–	1.35	V
			6.0	–	–	1.8	V
V <sub>OHI</sub>	HIGH-level output voltage	V <sub>I</sub> = V <sub>IH</sub> or V <sub>IL</sub> I <sub>O</sub> = -20 µA I <sub>O</sub> = -20 µA I <sub>O</sub> = -4.0 mA I <sub>O</sub> = -20 µA I <sub>O</sub> = -5.2 mA	2.0	1.9	–	–	V
			4.5	4.4	–	–	V
			4.5	3.84	–	–	V
			6.0	5.9	–	–	V
			6.0	5.34	–	–	V
V <sub>OOL</sub>	LOW-level output voltage	V <sub>I</sub> = V <sub>IH</sub> or V <sub>IL</sub> I <sub>O</sub> = 20 µA I <sub>O</sub> = 20 µA I <sub>O</sub> = 4.0 mA I <sub>O</sub> = 20 µA I <sub>O</sub> = 5.2 mA	2.0	–	–	0.1	V
			4.5	–	–	0.1	V
			4.5	–	–	0.33	V
			6.0	–	–	0.1	V
			6.0	–	–	0.33	V
I <sub>I</sub>	input leakage current	V <sub>I</sub> = V <sub>CC</sub> or GND	6.0	–	–	±1.0	µA
I <sub>OZ</sub>	3-state output OFF current	V <sub>I</sub> = V <sub>IH</sub> or V <sub>IL</sub> ; V <sub>O</sub> = V <sub>CC</sub> or GND	6.0	–	–	±5.0	µA
I <sub>CC</sub>	quiescent supply current	V <sub>I</sub> = V <sub>CC</sub> or GND; I <sub>O</sub> = 0	6.0	–	–	20	µA

## Hex inverter

## 74HC04; 74HCT04

SYMBOL	PARAMETER	TEST CONDITIONS		MIN.	TYP.	MAX.	UNIT
		OTHER	V <sub>CC</sub> (V)				
T <sub>amb</sub> = -40 to +125 °C							
V <sub>IH</sub>	HIGH-level input voltage		2.0	1.5	–	–	V
			4.5	3.15	–	–	V
			6.0	4.2	–	–	V
V <sub>IL</sub>	LOW-level input voltage		2.0	–	–	0.5	V
			4.5	–	–	1.35	V
			6.0	–	–	1.8	V
V <sub>OHI</sub>	HIGH-level output voltage	V <sub>I</sub> = V <sub>IH</sub> or V <sub>IL</sub> I <sub>O</sub> = -20 µA	2.0	1.9	–	–	V
		I <sub>O</sub> = -20 µA	4.5	4.4	–	–	V
		I <sub>O</sub> = -20 µA	6.0	5.9	–	–	V
		I <sub>O</sub> = -4.0 mA	4.5	3.7	–	–	V
		I <sub>O</sub> = -5.2 mA	6.0	5.2	–	–	V
V <sub>OOL</sub>	LOW-level output voltage	V <sub>I</sub> = V <sub>IH</sub> or V <sub>IL</sub> I <sub>O</sub> = 20 µA	2.0	–	–	0.1	V
		I <sub>O</sub> = 20 µA	4.5	–	–	0.1	V
		I <sub>O</sub> = 20 µA	6.0	–	–	0.1	V
		I <sub>O</sub> = 4.0 mA	4.5	–	–	0.4	V
		I <sub>O</sub> = 5.2 mA	6.0	–	–	0.4	V
I <sub>I1</sub>	input leakage current	V <sub>I</sub> = V <sub>CC</sub> or GND	6.0	–	–	±1.0	µA
I <sub>OZ</sub>	3-state output OFF current	V <sub>I</sub> = V <sub>IH</sub> or V <sub>IL</sub> ; V <sub>O</sub> = V <sub>CC</sub> or GND	6.0	–	–	±10.0	µA
I <sub>CC</sub>	quiescent supply current	V <sub>I</sub> = V <sub>CC</sub> or GND; I <sub>O</sub> = 0	6.0	–	–	40	µA

## Hex inverter

## 74HC04; 74HCT04

## Type 74HCT04

At recommended operating conditions; voltages are referenced to GND (ground = 0 V).

SYMBOL	PARAMETER	TEST CONDITIONS		MIN.	TYP.	MAX.	UNIT
		OTHER	V <sub>CC</sub> (V)				
T <sub>amb</sub> = 25 °C							
V <sub>HI</sub>	HIGH-level input voltage		4.5 to 5.5	2.0	1.6	–	V
V <sub>LI</sub>	LOW-level input voltage		4.5 to 5.5	–	1.2	0.8	V
V <sub>OHI</sub>	HIGH-level output voltage	V <sub>I</sub> = V <sub>HI</sub> or V <sub>LI</sub> I <sub>O</sub> = –20 µA	4.5	4.4	4.5	–	V
		I <sub>O</sub> = –4.0 mA	4.5	3.84	4.32	–	V
V <sub>OL</sub>	LOW-level output voltage	V <sub>I</sub> = V <sub>HI</sub> or V <sub>LI</sub> I <sub>O</sub> = 20 µA	4.5	–	0	0.1	V
		I <sub>O</sub> = 4.0 mA	4.5	–	0.15	0.26	V
I <sub>I1</sub>	input leakage current	V <sub>I</sub> = V <sub>CC</sub> or GND	5.5	–	–	±0.1	µA
I <sub>OZ</sub>	3-state output OFF current	V <sub>I</sub> = V <sub>HI</sub> or V <sub>LI</sub> ; V <sub>O</sub> = V <sub>CC</sub> or GND; I <sub>O</sub> = 0	5.5	–	–	±0.5	µA
I <sub>CC</sub>	quiescent supply current	V <sub>I</sub> = V <sub>CC</sub> or GND; I <sub>O</sub> = 0	5.5	–	–	2	µA
ΔI <sub>CC</sub>	additional supply current per input	V <sub>I</sub> = V <sub>CC</sub> – 2.1 V; I <sub>O</sub> = 0	4.5 to 5.5	–	120	432	µA
T <sub>amb</sub> = –40 to +85 °C							
V <sub>HI</sub>	HIGH-level input voltage		4.5 to 5.5	2.0	–	–	V
V <sub>LI</sub>	LOW-level input voltage		4.5 to 5.5	–	–	0.8	V
V <sub>OHI</sub>	HIGH-level output voltage	V <sub>I</sub> = V <sub>HI</sub> or V <sub>LI</sub> I <sub>O</sub> = –20 µA	4.5	4.4	–	–	V
		I <sub>O</sub> = –4.0 mA	4.5	3.84	–	–	V
V <sub>OL</sub>	LOW-level output voltage	V <sub>I</sub> = V <sub>HI</sub> or V <sub>LI</sub> I <sub>O</sub> = 20 µA	4.5	–	–	0.1	V
		I <sub>O</sub> = 4.0 mA	4.5	–	–	0.33	V
I <sub>I1</sub>	input leakage current	V <sub>I</sub> = V <sub>CC</sub> or GND	5.5	–	–	±1.0	µA
I <sub>OZ</sub>	3-state output OFF current	V <sub>I</sub> = V <sub>HI</sub> or V <sub>LI</sub> ; V <sub>O</sub> = V <sub>CC</sub> or GND; I <sub>O</sub> = 0	5.5	–	–	±5.0	µA
I <sub>CC</sub>	quiescent supply current	V <sub>I</sub> = V <sub>CC</sub> or GND; I <sub>O</sub> = 0	5.5	–	–	20	µA
ΔI <sub>CC</sub>	additional supply current per input	V <sub>I</sub> = V <sub>CC</sub> – 2.1 V; I <sub>O</sub> = 0	4.5 to 5.5	–	–	540	µA

## Hex inverter

## 74HC04; 74HCT04

SYMBOL	PARAMETER	TEST CONDITIONS		MIN.	TYP.	MAX.	UNIT
		OTHER	V <sub>CC</sub> (V)				
T <sub>amb</sub> = -40 to +125 °C							
V <sub>IH</sub>	HIGH-level input voltage		4.5 to 5.5	2.0	–	–	V
V <sub>IL</sub>	LOW-level input voltage		4.5 to 5.5	–	–	0.8	V
V <sub>OHI</sub>	HIGH-level output voltage	V <sub>I</sub> = V <sub>IH</sub> or V <sub>IL</sub> I <sub>O</sub> = -20 µA	4.5	4.4	–	–	V
		I <sub>O</sub> = -4.0 mA	4.5	3.7	–	–	V
V <sub>OOL</sub>	LOW-level output voltage	V <sub>I</sub> = V <sub>IH</sub> or V <sub>IL</sub> I <sub>O</sub> = 20 µA	4.5	–	–	0.1	V
		I <sub>O</sub> = 4.0 mA	4.5	–	–	0.4	V
I <sub>I</sub>	Input leakage current	V <sub>I</sub> = V <sub>CC</sub> or GND	5.5	–	–	±1.0	µA
I <sub>OZ</sub>	3-state output OFF current	V <sub>I</sub> = V <sub>IH</sub> or V <sub>IL</sub> ; V <sub>O</sub> = V <sub>CC</sub> or GND; I <sub>O</sub> = 0	5.5	–	–	±10	µA
I <sub>CC</sub>	quiescent supply current	V <sub>I</sub> = V <sub>CC</sub> or GND; I <sub>O</sub> = 0	5.5	–	–	40	µA
ΔI <sub>CC</sub>	additional supply current per input	V <sub>I</sub> = V <sub>CC</sub> - 2.1 V; I <sub>O</sub> = 0	4.5 to 5.5	–	–	550	µA

## Hex inverter

74HC04; 74HCT04

## AC CHARACTERISTICS

Family 74HC04

GND = 0 V;  $t_r = t_f \leq 6.0$  ns;  $C_L = 50$  pF.

SYMBOL	PARAMETER	TEST CONDITIONS		MIN.	TYP.	MAX.	UNIT
		WAVEFORMS	V <sub>CC</sub> (V)				
T <sub>amb</sub> = 25 °C							
t <sub>PHL</sub> /t <sub>PLH</sub>	propagation delay nA to nY	see Figs 6 and 7	2.0	–	25	85	ns
			4.5	–	9	17	ns
			6.0	–	7	14	ns
t <sub>HL</sub> /t <sub>LH</sub>	output transition time	see Figs 6 and 7	2.0	–	19	75	ns
			4.5	–	7	15	ns
			6.0	–	6	13	ns
T <sub>amb</sub> = –40 to +86 °C							
t <sub>PHL</sub> /t <sub>PLH</sub>	propagation delay nA to nY	see Figs 6 and 7	2.0	–	–	105	ns
			4.5	–	–	21	ns
			6.0	–	–	18	ns
t <sub>HL</sub> /t <sub>LH</sub>	output transition time	see Figs 6 and 7	2.0	–	–	95	ns
			4.5	–	–	19	ns
			6.0	–	–	16	ns
T <sub>amb</sub> = –40 to +126 °C							
t <sub>PHL</sub> /t <sub>PLH</sub>	propagation delay nA to nY	see Figs 6 and 7	2.0	–	–	130	ns
			4.5	–	–	26	ns
			6.0	–	–	22	ns
t <sub>HL</sub> /t <sub>LH</sub>	output transition time	see Figs 6 and 7	2.0	–	–	110	ns
			4.5	–	–	22	ns
			6.0	–	–	19	ns

## Hex inverter

74HC04; 74HCT04

## Family 74HC04

GND = 0 V;  $t_r = t_f \leq 6.0$  ns;  $C_L = 50$  pF.

SYMBOL	PARAMETER	TEST CONDITIONS		MIN.	TYP.	MAX.	UNIT
		WAVEFORMS	$V_{CC}$ (V)				
$T_{amb} = 25$ °C							
$t_{PHL}/t_{PLH}$	propagation delay nA to nY	see Figs 6 and 7	4.5	–	10	19	ns
$t_{THL}/t_{TLH}$	output transition time	see Figs 6 and 7	4.5	–	7	15	ns
$T_{amb} = -40$ to $+86$ °C							
$t_{PHL}/t_{PLH}$	propagation delay nA to nY	see Figs 6 and 7	4.5	–	–	24	ns
$t_{THL}/t_{TLH}$	output transition time	see Figs 6 and 7	4.5	–	–	19	ns
$T_{amb} = -40$ to $+126$ °C							
$t_{PHL}/t_{PLH}$	propagation delay nA to nY	see Figs 6 and 7	4.5	–	–	29	ns
$t_{THL}/t_{TLH}$	output transition time	see Figs 6 and 7	4.5	–	–	22	ns

## AC WAVEFORMS

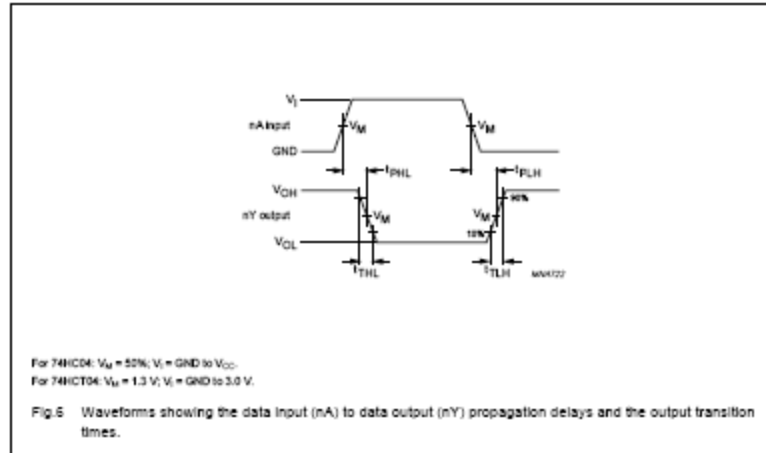

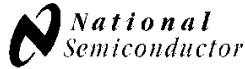

June 2005

LM2930 3-Terminal Positive Regulator

## LM2930 3-Terminal Positive Regulator

### General Description

The LM2930 3-terminal positive regulator features an ability to source 150 mA of output current with an input-output differential of 0.6V or less. Efficient use of low input voltages obtained, for example, from an automotive battery during cold crank conditions, allows 5V circuitry to be properly powered with supply voltages as low as 5.6V. Familiar regulator features such as current limit and thermal overload protection are also provided.

Designed originally for automotive applications, the LM2930 and all regulated circuitry are protected from reverse battery installations or 2 battery jumps. During line transients, such as a load dump (40V) when the input voltage to the regulator can momentarily exceed the specified maximum operating voltage, the regulator will automatically shut down to protect both internal circuits and the load. The LM2930 cannot be harmed by temporary mirror-image insertion.

Fixed outputs of 5V and 8V are available in the plastic TO-220 and TO-263 power packages.

### Features

- Input-output differential less than 0.6V
- Output current in excess of 150 mA
- Reverse battery protection
- 40V load dump protection
- Internal short circuit current limit
- Internal thermal overload protection
- Mirror-image insertion protection
- P: Product Enhancement tested

### Voltage Range

- |                |    |
|----------------|----|
| ■ LM2930T-5.0: | 5V |
| ■ LM2930T-8.0: | 8V |
| ■ LM2930S-5.0: | 5V |
| ■ LM2930S-8.0: | 8V |

### Connection Diagram

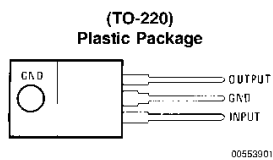

Front View  
Order Number LM2930T-5.0 or LM2930T-8.0  
See NS Package Number T03B

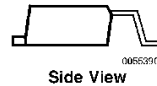

Order Number LM2930S-5.0 or LM2930S-8.0  
See NS Package Number TS3B

### (TO-263) Plastic Surface-Mount Package

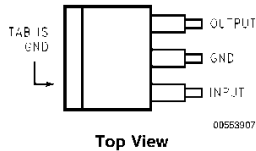

Top View



**Absolute Maximum Ratings** (Note 1)

If Military/Aerospace specified devices are required, please contact the National Semiconductor Sales Office/Distributors for availability and specifications.

Input Voltage	
Operating Range	26V
Overvoltage Protection	40V
Reverse Voltage (100 ms)	-12V

Reverse Voltage (DC)	-6V
Internal Power Dissipation (Note 2)	Internally Limited
Operating Temperature Range	-40°C to +85°C
Maximum Junction Temperature	125°C
Storage Temperature Range	-65°C to +150°C
Lead Temp. (Soldering, 10 seconds)	230°C

**Electrical Characteristics** (Note 3)

LM2930-5.0  $V_{IN}=14V$ ,  $I_O=150\text{ mA}$ ,  $T_J=25^\circ\text{C}$  (Note 6),  $C_2=10\ \mu\text{F}$ , unless otherwise specified

Parameter	Conditions	Typ	Tested Limit (Note 4)	Design Limit (Note 5)	Unit
Output Voltage		5	5.3 4.7		$V_{MAX}$ $V_{MIN}$
	$6V \leq V_{IN} \leq 26V$ , $5\text{ mA} \leq I_O \leq 150\text{ mA}$ $-40^\circ\text{C} \leq T_J \leq 125^\circ\text{C}$			5.5 4.5	$V_{MAX}$ $V_{MIN}$
Line Regulation	$9V \leq V_{IN} \leq 16V$ , $I_O=5\text{ mA}$	7	25		$\text{mV}_{MAX}$
	$6V \leq V_{IN} \leq 26V$ , $I_O=5\text{ mA}$	30	80		$\text{mV}_{MAX}$
Load Regulation	$5\text{ mA} \leq I_O \leq 150\text{ mA}$	14	50		$\text{mV}_{MAX}$
Output Impedance	$100\text{ mA}_{DC}$ & $10\text{ mA}_{rms}$ , 100 Hz–10 kHz	200			$\text{m}\Omega$
Quiescent Current	$I_O=10\text{ mA}$	4	7		$\text{mA}_{MAX}$
	$I_O=150\text{ mA}$	18	40		$\text{mA}_{MAX}$
Output Noise Voltage	10 Hz–100 kHz	140			$\mu\text{V}_{rms}$
Long Term Stability		20			$\text{mV}/1000\text{ hr}$
Ripple Rejection	$f_O=120\text{ Hz}$	56			dB
Current Limit		400	700 150		$\text{mA}_{MAX}$ $\text{mA}_{MIN}$
Dropout Voltage	$I_O=150\text{ mA}$	0.32	0.6		$V_{MAX}$
Output Voltage Under Transient Conditions	$-12V \leq V_{IN} \leq 40V$ , $R_L=100\Omega$		5.5		$V_{MAX}$
			-0.3		$V_{MIN}$

**Electrical Characteristics** (Note 3)

LM2930-8.0 ( $V_{IN}=14V$ ,  $I_O=150\text{ mA}$ ,  $T_J=25^\circ\text{C}$  (Note 6),  $C_2=10\ \mu\text{F}$ , unless otherwise specified)

Parameter	Conditions	Typ	Tested Limit (Note 4)	Design Limit (Note 5)	Unit
Output Voltage		8	8.5 7.5		$V_{MAX}$ $V_{MIN}$
	$9.4V \leq V_{IN} \leq 26V$ , $5\text{ mA} \leq I_O \leq 150\text{ mA}$ , $-40^\circ\text{C} \leq T_J \leq 125^\circ\text{C}$			8.8 7.2	$V_{MAX}$ $V_{MIN}$
Line Regulation	$9.4V \leq V_{IN} \leq 16V$ , $I_O=5\text{ mA}$	12	50		$\text{mV}_{MAX}$
	$9.4V \leq V_{IN} \leq 26V$ , $I_O=5\text{ mA}$	50	100		$\text{mV}_{MAX}$
Load Regulation	$5\text{ mA} \leq I_O \leq 150\text{ mA}$	25	50		$\text{mV}_{MAX}$
Output Impedance	$100\text{ mA}_{DC}$ & $10\text{ mA}_{rms}$ , 100 Hz–10 kHz	300			$\text{m}\Omega$
Quiescent Current	$I_O=10\text{ mA}$	4	7		$\text{mA}_{MAX}$
	$I_O=150\text{ mA}$	18	40		$\text{mA}_{MAX}$
Output Noise Voltage	10 Hz–100 kHz	170			$\mu\text{V}_{rms}$
Long Term Stability		30			$\text{mV}/1000\text{ hr}$
Ripple Rejection	$f_O=120\text{ Hz}$	52			dB

**Electrical Characteristics** (Note 3) (Continued)LM2930-8.0 ( $V_{IN}=14V$ ,  $I_O=150$  mA,  $T_J=25^\circ\text{C}$  (Note 6),  $C_2=10$   $\mu\text{F}$ , unless otherwise specified)

Parameter	Conditions	Typ	Tested Limit (Note 4)	Design Limit (Note 5)	Unit
Current Limit		400	700		$\text{mA}_{MAX}$
			150		$\text{mA}_{MIN}$
Dropout Voltage	$I_O=150$ mA	0.32	0.6		$V_{MAX}$
Output Voltage Under Transient Conditions	$-12V \leq V_{IN} \leq 40V$ , $R_L=100\Omega$		8.8		$V_{MAX}$
			-0.3		$V_{MIN}$

**Note 1:** Absolute Maximum Ratings indicate limits beyond which damage to the device may occur. Operating ratings indicate conditions for which the device is functional, but do not guarantee specific performance limits. Electrical Characteristics state DC and AC electrical specifications under particular test conditions which guarantee specific performance limits. This assumes that the device is within the Operating Ratings. Specifications are not guaranteed for parameters where no limit is given, however, the typical value is a good indication of device performance.

**Note 2:** Thermal resistance without a heat sink for junction to case temperature is  $3^\circ\text{C/W}$  and for case to ambient temperature is  $50^\circ\text{C/W}$  for the TO-220.  $73^\circ\text{C/W}$  for the TO-263. If the TO-263 package is used, the thermal resistance can be reduced by increasing the P.C. board copper area thermally connected to the package. Using 0.5 square inches of copper area,  $\theta_{JA}$  is  $50^\circ\text{C/W}$ ; with 1 square inch of copper area,  $\theta_{JA}$  is  $37^\circ\text{C/W}$ ; and with 1.6 or more square inches of copper area,  $\theta_{JA}$  is  $32^\circ\text{C/W}$ .

**Note 3:** All characteristics are measured with a capacitor across the input of  $0.1$   $\mu\text{F}$  and a capacitor across the output of  $10$   $\mu\text{F}$ . All characteristics except noise voltage and ripple rejection ratio are measured using pulse techniques ( $t_W \leq 10$  ms, duty cycle  $\leq 5\%$ ). Output voltage changes due to changes in internal temperature must be taken into account separately.

**Note 4:** Guaranteed and 100% production tested.

**Note 5:** Guaranteed (but not 100% production tested) over the operating temperature and input current ranges. These limits are not used to calculate outgoing quality levels.

**Note 6:** To ensure constant junction temperature, low duty cycle pulse testing is used.

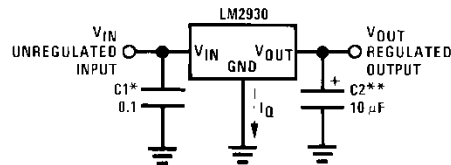
**Typical Application**

00553905

\*Required if regulator is located far from power supply filter.

\*\* $C_{OUT}$  must be at least  $10$   $\mu\text{F}$  to maintain stability. May be increased without bound to maintain regulation during transients. Locate as close as possible to the regulator. This capacitor must be rated over the same operating temperature range as the regulator. The equivalent series resistance (ESR) of this capacitor should be less than  $1\Omega$  over the expected operating temperature range.

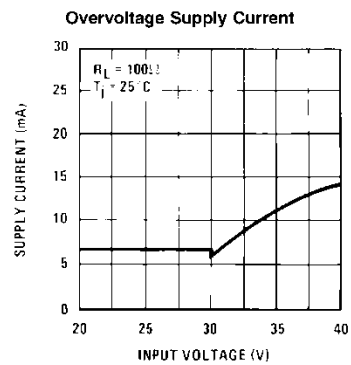
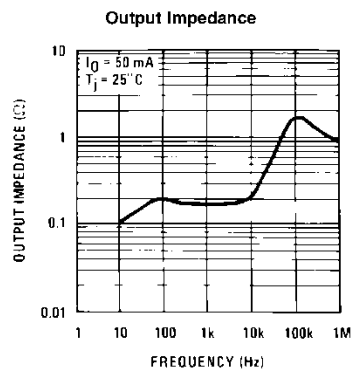
**Typical Performance Characteristics**

Typical Performance Characteristics (Continued)

Reverse Supply Current

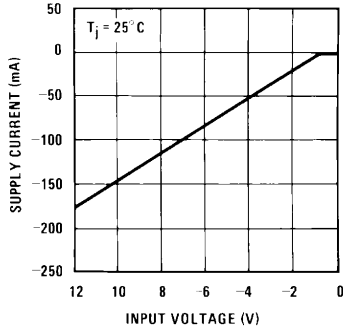

00553913

Output at Reverse Supply

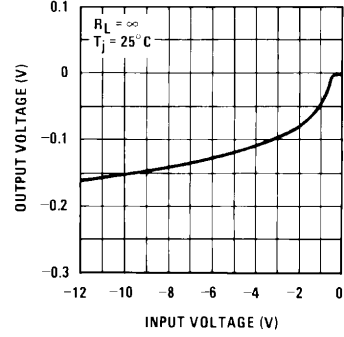

00553914

Output at Overvoltage

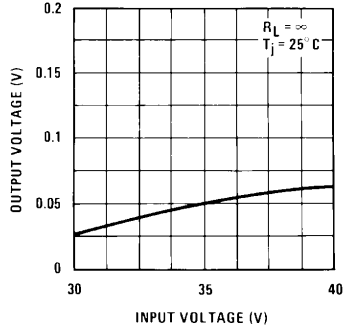

00553915

Output Voltage (Normalized to 1V at Tj=25°C)

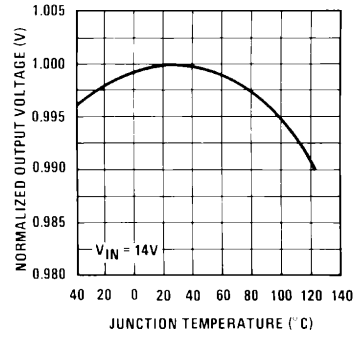

00553916

Dropout Voltage

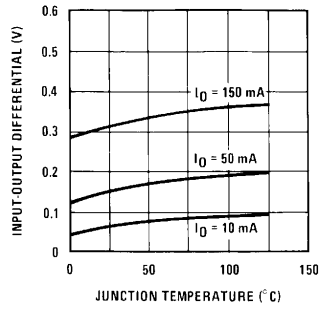

00553917

Dropout Voltage

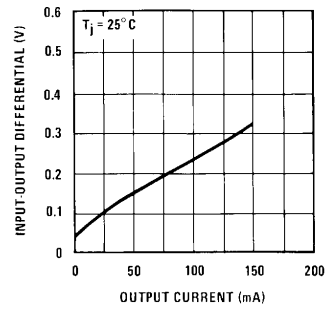

00553918

Typical Performance Characteristics (Continued)

Low Voltage Behavior

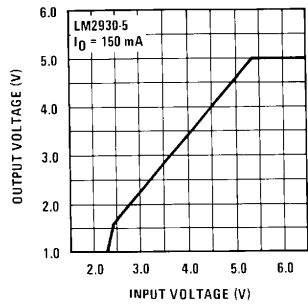

00553919

High Voltage Behavior

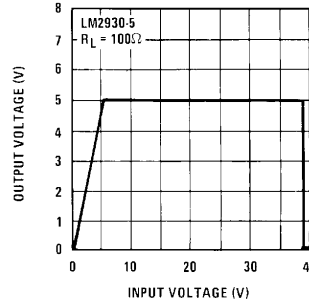

00553920

Line Transient Response

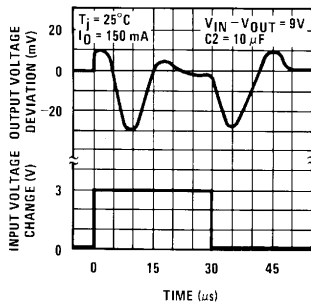

00553921

Load Transient Response

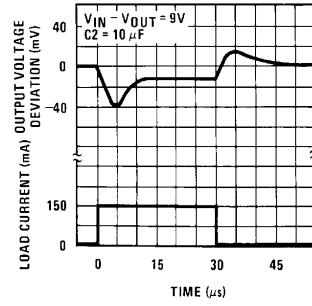

00553922

Peak Output Current

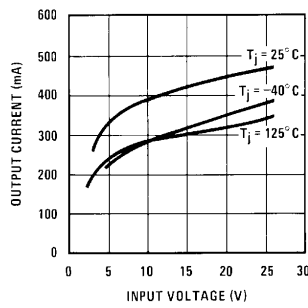

00553923

Quiescent Current

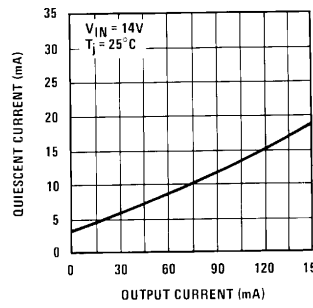

00553924

## Typical Performance Characteristics (Continued)

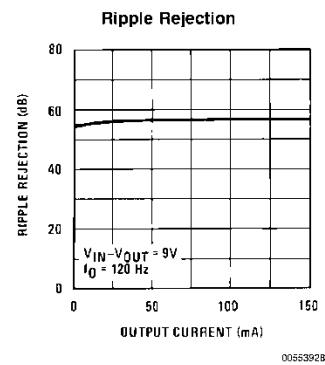
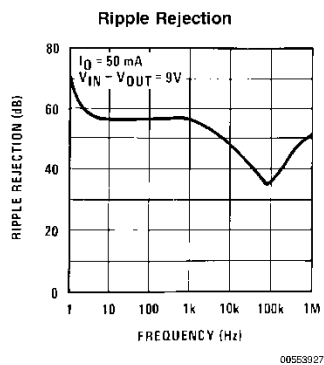
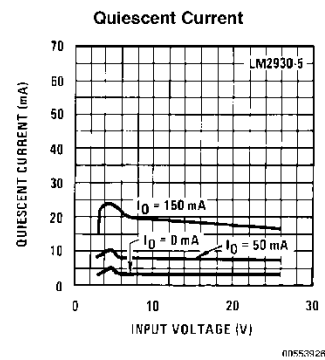
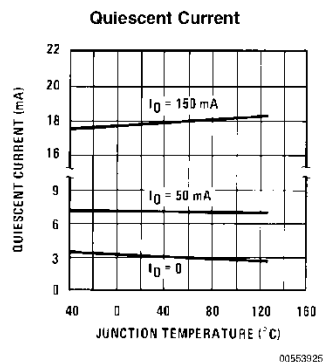

### Definition of Terms

**Dropout Voltage:** The input-output voltage differential at which the circuit ceases to regulate against further reduction in input voltage. Measured when the output voltage has dropped 100 mV from the nominal value obtained at 14V input, dropout voltage is dependent upon load current and junction temperature.

**Input Voltage:** The DC voltage applied to the input terminals with respect to ground.

**Input-Output Differential:** The voltage difference between the unregulated input voltage and the regulated output voltage for which the regulator will operate.

**Line Regulation:** The change in output voltage for a change in the input voltage. The measurement is made under conditions of low dissipation or by using pulse techniques such that the average chip temperature is not significantly affected.

**Load Regulation:** The change in output voltage for a change in load current at constant chip temperature.

**Long Term Stability:** Output voltage stability under accelerated life-test conditions after 1000 hours with maximum rated voltage and junction temperature.

**Output Noise Voltage:** The rms AC voltage at the output, with constant load and no input ripple, measured over a specified frequency range.

**Quiescent Current:** That part of the positive input current that does not contribute to the positive load current. The regulator ground lead current.

**Ripple Rejection:** The ratio of the peak-to-peak input ripple voltage to the peak-to-peak output ripple voltage.

**Temperature Stability of  $V_O$ :** The percentage change in output voltage for a thermal variation from room temperature to either temperature extreme.

Definition of Terms (Continued)

Maximum Power Dissipation (TO-220)

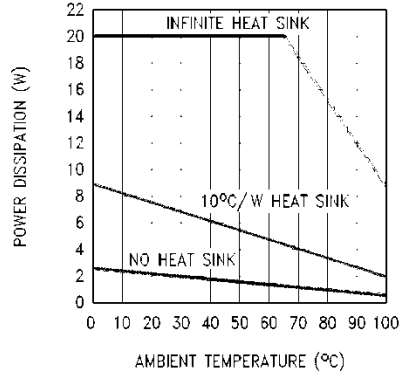

01553008

Maximum Power Dissipation (TO-263) (Note 2)

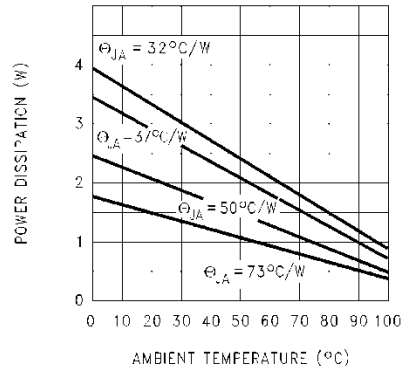

01553009

### Schematic Diagram

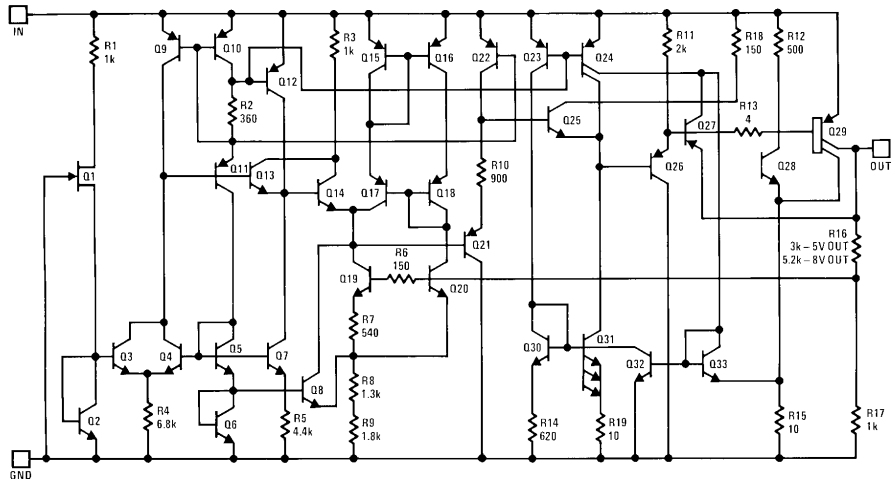

00553910

**Physical Dimensions** inches (millimeters)  
 unless otherwise noted

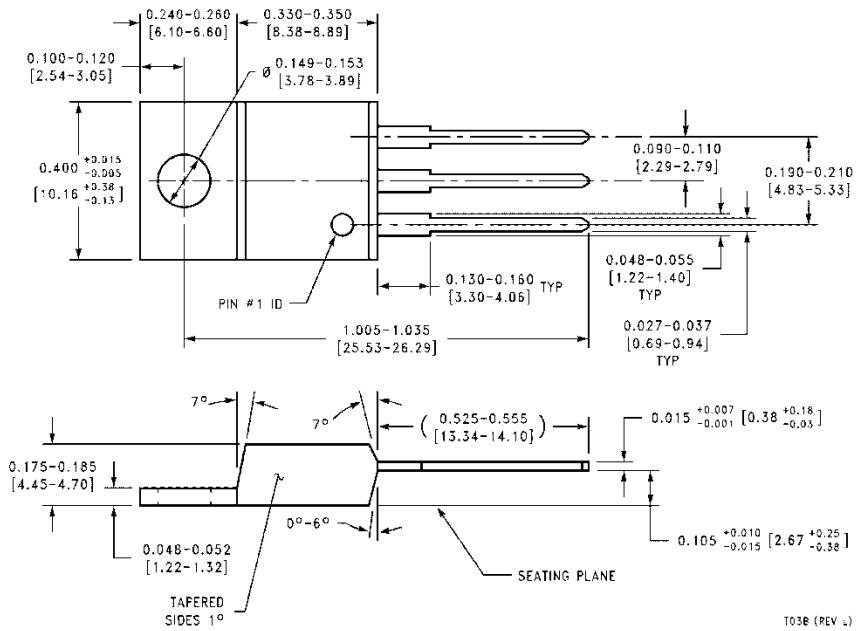

**TO-220 3-Lead Molded Package**  
 Order Number LM2930T-5.0 or LM2930T-8.0  
 NS Package Number T03B

T03B (REV. L)



**Physical Dimensions** inches (millimeters) unless otherwise noted (Continued)

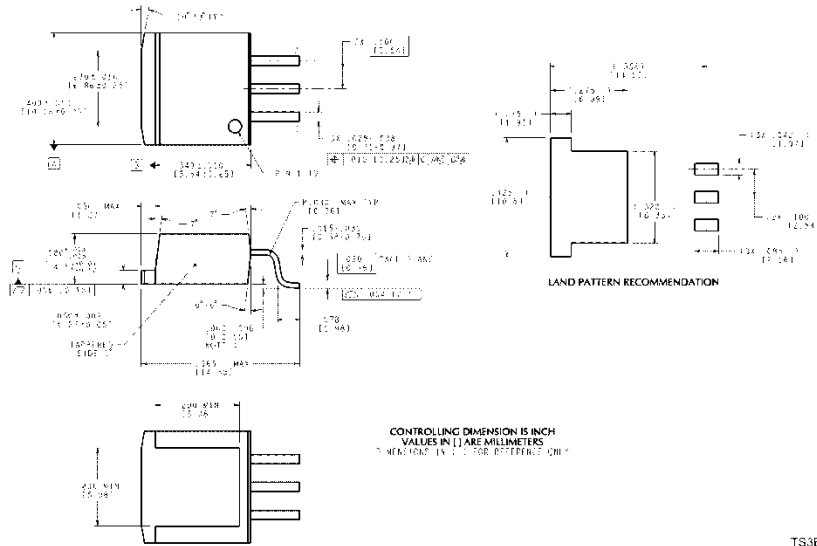

**TO-263 3-Lead Plastic Surface Mount Package**  
**Order Number LM2930S-5.0 or LM2930S-8.0**  
**NS Package Number TS3B**

TS3B (Rev F)

National does not assume any responsibility for use of any circuitry described, no circuit patent licenses are implied and National reserves the right at any time without notice to change said circuitry and specifications.  
 For the most current product information visit us at [www.national.com](http://www.national.com).

**LIFE SUPPORT POLICY**

NATIONAL'S PRODUCTS ARE NOT AUTHORIZED FOR USE AS CRITICAL COMPONENTS IN LIFE SUPPORT DEVICES OR SYSTEMS WITHOUT THE EXPRESS WRITTEN APPROVAL OF THE PRESIDENT AND GENERAL COUNSEL OF NATIONAL SEMICONDUCTOR CORPORATION. As used herein:

1. Life support devices or systems are devices or systems which, (a) are intended for surgical implant into the body, or (b) support or sustain life, and whose failure to perform when properly used in accordance with instructions for use provided in the labeling, can be reasonably expected to result in a significant injury to the user.
2. A critical component is any component of a life support device or system whose failure to perform can be reasonably expected to cause the failure of the life support device or system, or to affect its safety or effectiveness.

**BANNED SUBSTANCE COMPLIANCE**

National Semiconductor manufactures products and uses packing materials that meet the provisions of the Customer Products Stewardship Specification (CSP-9-111C2) and the Banned Substances and Materials of Interest Specification (CSP-9-111S2) and contain no "Banned Substances" as defined in CSP-9-111S2.

Leadfree products are RoHS compliant.

 National Semiconductor  
 Americas Customer Support Center  
 Email: [new.feedback@nsc.com](mailto:new.feedback@nsc.com)  
 Tel: 1-800-272-9959

National Semiconductor  
 Europe Customer Support Center  
 Fax: +49 (0) 180-530 85 86  
 Email: [europe.support@nsc.com](mailto:europe.support@nsc.com)  
 Deutsch Tel: +49 (0) 69 9508 6208  
 English Tel: +44 (0) 870 24 0 2171  
 Français Tel: +33 (0) 1 41 91 8790

National Semiconductor  
 Asia Pacific Customer Support Center  
 Email: [ap.support@nsc.com](mailto:ap.support@nsc.com)

National Semiconductor  
 Japan Customer Support Center  
 Fax: 81-3-5639-7507  
 Email: [jpn.feedback@nsc.com](mailto:jpn.feedback@nsc.com)  
 Tel: 81-3-5639-7560

[www.national.com](http://www.national.com)

## Tri-colored LED

### TriColor **RED** **GREEN** **BLUE** LED

This full color super bright LED contains red green and blue LEDs housed in a single 5mm epoxy package They are available with water clear or milky white diffused lenses as part numbers RL5-RGB-C and RL5-RGB-D Available with common CATHODE or ANODE

[CLICK HERE TO BUY ONLINE NOW](#)

We also offer an automatic color changing RGB LED.

[CLICK HERE TO SEE SPECS](#)

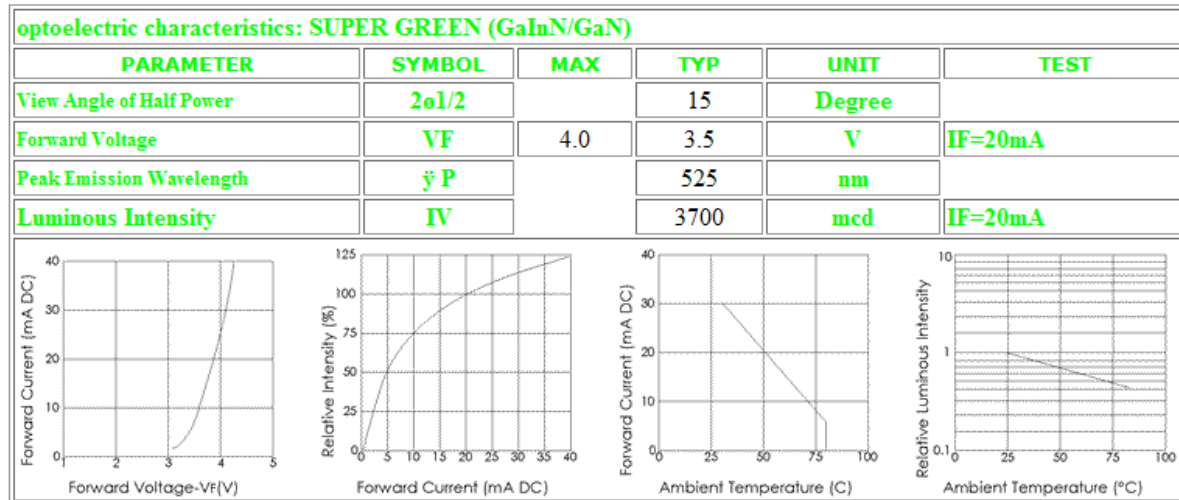
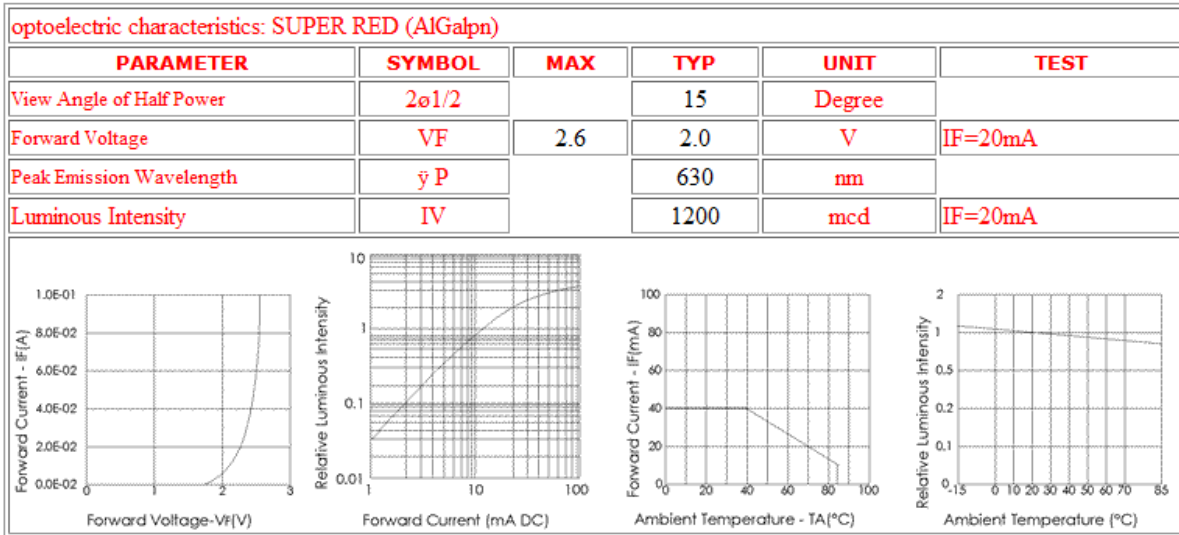

optoelectric characteristics: SUPER BLUE (GaN)

PARAMETER	SYMBOL	MAX	TYP	UNIT	TEST
View Angle of Half Power	$2\theta_{1/2}$		15	Degree	
Forward Voltage	V <sub>F</sub>	4.0	3.5	V	I <sub>F</sub> =20mA
Peak Emission Wavelength	$\lambda_P$		472	nm	
Luminous Intensity	I <sub>V</sub>		700	mcd	I <sub>F</sub> =20mA

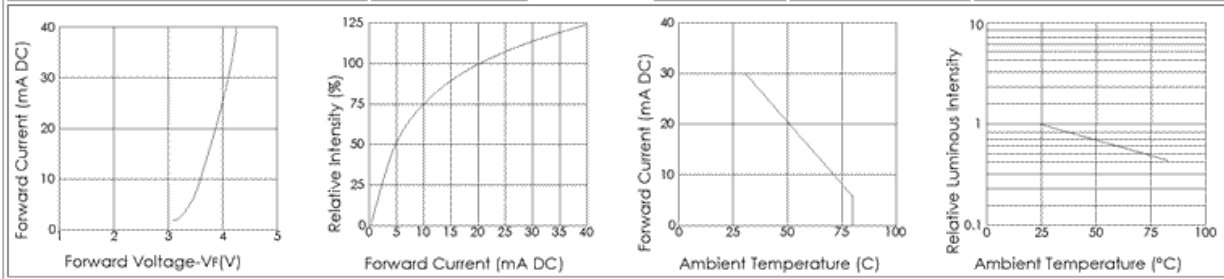

AVAILABLE WITH COMMON CATHODE OR COMMON ANODE

absolute maximum ratings: (T<sub>A</sub>=25°C, per individual LED) PART NUMBERS RL5-RGB-C and RL5-RGB-D

PARAMETER	SYMBOL	RATING	UNIT
Power Dissipation	PD	100	mW
Continuous Forward Current	I <sub>F</sub>	20	mA
Peak Forward Current (1/10th duty cycle, 0.1ms pulse width)	I <sub>FM</sub>	50	mA
Reverse Voltage	V <sub>R</sub>	5.0	V
Operating Temperature	T <sub>A</sub>	-40~+85	°C
Storage Temperature	T <sub>STG</sub>	-40~+85	°C
Reverse Current (V <sub>R</sub> =5V)	I <sub>R</sub>	10	μA

Lead Soldering Temperature (3mm from body) 260C (for 3 seconds)

[CLICK HERE FOR PRICING AND TO BUY ONLINE NOW](#)

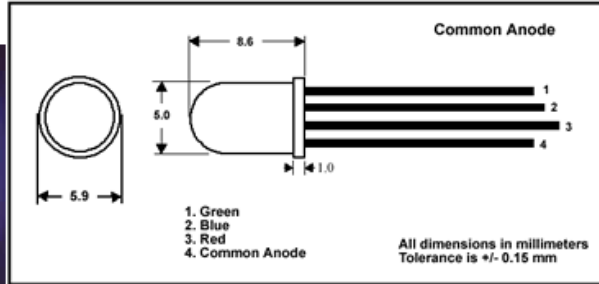
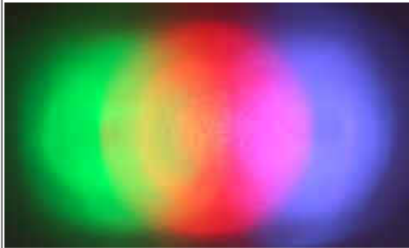
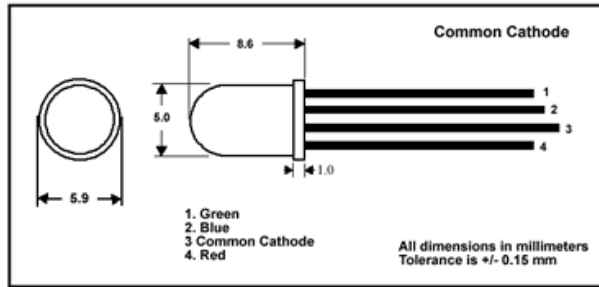

LEADS ARE 0.48mm x 0.48mm square - LEAD SPACING IS 1.25mm - LEAD LENGTH IS 24mm to 28mm

## Appendix F: Weekly Progress Reports

Jacqui Richardson

Nate Osgood

June-Chi Hong

Week 3 Progress Report

This week we finished building the Boss Metal Zone pedal. We followed the circuit at each node with a 440Hz, 150mV sinusoidal waveform (an 'A' note on the guitar) and took pictures on the oscilloscope. Then we applied a real guitar signal as an input to our pedal and there was significant noise on the signal. Even with no signal applied we observed a significant amount of noise when looking at node voltages in the frequency domain. One thing we noticed was that the potentiometers caused disruption in the signal when we adjusted them. In an attempt to decrease this noise we replaced the potentiometers with resistor values set at the midway values, shortened the long wires in our circuit, and added filter capacitors to every power supply rail on the board (as suggested by Professor Loof). Our attempts decreased the noise significantly, but the guitar signal was still too noisy. We feel that it may have something to do with the capacitance of the breadboards.

We also noticed that the bass and treble knobs in the equalizer block were not entirely independent. We saw that in the frequency domain when we turned up the treble, some of the bass frequencies were cut and vice versa. We decided that this block needed to be redesigned and started looking into other equalizer options, such as equalizer ICs. Instead of having three frequency bands (bass, mid, and treble), we could use two five band equalizer chips to divide the frequency ranges into ten bands for more sounds. Although this is a more expensive option, it is unique for a pedal to have a ten band equalizer and this functionality adds value to our design.

We have also been looking into other pedals for alternate configuration ideas for functional blocks of our pedal.

### **Power Block**

The power block provides a 9V power supply rail and a 4.5V power supply rail from the 9V rail using a voltage divider (equation shown below). There are two filter capacitors going from each power supply to ground and a 9V zener diode to keep the voltage at 9V.

$$\frac{10k\Omega}{10k\Omega + 10k\Omega} \times 9v = 4.5v$$

### **Input Buffer**

The base is tied to a 4.5V bias through a 1M $\Omega$  resistor. The buffer is there to match the impedance of the guitar signal coming in.

## **First Gain Stage**

The first gain stage consists of an op-amp configured with non-inverting negative feedback. The gain equation is  $(1+Z_2/Z_1)$  where  $Z_2$  is the parallel impedance of the 47pF capacitor and the 1k $\Omega$  resistor plus the variable resistance of the potentiometer and  $Z_1$  is the 1k $\Omega$  resistor and 10uF capacitor in series. At very high frequencies, the capacitor acts as a short circuit and no amplification occurs. At very low frequencies the capacitor acts as an open circuit, and the frequencies are cut due to the high-pass filter configuration of the 1k $\Omega$  resistor and 10uF capacitor.

## **Diode Clipping**

The 10uF capacitor before the diode clipping stage blocks the DC offset of the signal. The signal is then clipped to the forward voltage of the diodes. From lab we measured this to be  $\pm 0.544\text{V}$ .

## **Filtering stage**

The filtering stage emphasizes two specific frequencies. The gain at this stage, like the first gain stage, is  $(1+Z_2/Z_1)$  because the signal is non-inverting and connected for negative feedback. Here  $Z_2$  is the parallel impedance of the 47pF capacitor and the 3.3k $\Omega$  resistor.  $Z_1$  is the total impedance of the transistor network at the bottom. The signal then goes to another op amp with negative feedback and an inverting output. This op amp has a gain of -1 and acts as a low-pass filter because at very high frequencies the capacitor is shorted.

## **Equalizer Stage**

For the equalizer stage we are using two 5-band equalizers to produce a 10-band equalizer. The frequency range of 16 kHz is divided into ten bands. Each frequency in this range is determined by the capacitor configuration around the chip. The frequencies range from 100Hz to 6.2kHz, a common frequency range for guitar. The equation for the Q frequencies in Hertz is shown below.

$$F_{Hz} = \frac{1}{2\pi\sqrt{1.2k \times 68k \times C_A \times C_B}}$$

### **Output Filtering**

In this stage there is a potentiometer to change the output level, or volume, of the signal. Following the volume control is an emitter follower to match the impedance of an amplifier, which is generally about 1MΩ or higher.



We are slightly behind and will most likely need to use the buffer week (Week 7) to catch up. We will still make deadline. Below is our current plan for scheduling:

Week 2: building and analyzing the Boss pedal to understand it conceptually

Week 3: Use our understanding of the Boss pedal and other research we have gathered to design our own distortion pedal

Week 4: Test and optimize our schematic, order parts, do PCB layout and order PCB

Week 5: Build and test circuit on PCB

Week 6: Build or buy an aluminum case and add finishing touches

Week 7: Buffer time/work on paper/design reiteration

June Chi Hong  
Jacqui Richardson  
Nate Osgood  
Guitar Distortion Pedal MQP  
Week 4 progress report

In this week, we ordered more parts for our pedal design. Those parts contain a 10-band equalizer and distortion design we discovered that contains a clipping circuit and three cascading gain stages with simpler op-amp and inverter application. We spent couple of days waiting for the parts to arrive. We completed and tested the distortion design on breadboard. We took the waveforms for the output of each stage of this design and successfully obtained proper plots as we expected. Some noise could still be observed at the final stage. However, after testing it with practical guitar signal, we were surprised that this new design provides much cleaner output compared to the initial design. There was barely any noise that we could hear. We assumed that the smaller breadboard and shorter wires do help reduce the noise for the entire design. But we also realized that with a better design, the noise gate could be even unnecessary before the output.

Due to some unreasonable delay, the 10-band equalizer just arrived yesterday as it should've been here last week. We figured that the given box shipped along with the equalizer is incapable of containing all parts of our design, so we'll have to design a new box on our own. A lot of soldering will have to be done in this week to come up with practical circuit on PCB.

Our next step is to truly design our own circuit based on what we've learn from those designs we have examined so far. We think that our final design will have following stages: clipping circuit, gain stage(s), equalizer. We're now working on designing new power block and switching circuit that controls the entire pedal. What we'd like to see is LED indicators lighting with different

colors as the distortion circuit and equalization circuits in the pedal are on or off. We plan to use a tricolor LED with a common cathode to accomplish this. Also, there should be only one power block to source everything.

Next week we'll be working on putting the parts we have together to observe how the equalizer works with the distortion design. We generally believe that the combination will improve the output signal. Once our design is verified this way, we will start working on the PCB design.

We believe we are on schedule to complete on time, given our buffer week.

Week 4: Test and optimize our schematic, order parts, do PCB layout and order PCB

Week 5: Build and test circuit on PCB

Week 6: Build or buy an aluminum case and add finishing touches

Week 7: Buffer time/work on paper/design reiteration

June Chi Hong  
Jacqui Richardson  
Nate Osgood  
Guitar Distortion Pedal MQP  
Week 5 progress report

In this week, we built the 10-band equalizer on a PCB as a proof of concept to test it interfaced with the distortion circuit. We had some issues with this. The first thing that was wrong is that we forgot to solder a few components that effectively opened critical signal paths in the circuit. When we tested it with a guitar signal, it sounded great out of the distortion circuit, but once we listened to the output after the equalizer, the signal was completely attenuated and barely audible. This issue was fixed when we soldered the missing components into the circuit. Once this was resolved we could hear the output on our speaker, but the equalizer was not as responsive as we would have liked, so we changed a resistor value in the feedback loop of an amplifier in the equalizer circuit (and changed the capacitor in parallel with it so that the filtering was still the same cutoff frequency). With this new resistor, we are able to get more gain per equalizer band to make adjustments on the equalizer setting have a more noticeable effect on the sound. This worked wonderfully and the sound was much better than expected, until a connection on the board failed, and we had to resolder the jacks. In resoldering these jacks, we damaged the solder-through holes on the PCB accidentally, and now they are intermittent connections. This is not an issue because we are redesigning the PCB on our own, to include the entire circuit on a single board, so we will not be reusing this PCB for the final design.

We also designed the distortion circuit PCB layout, and had it examined for design mistakes by Pat in the ECE shop, he said everything looked good, as well as gave us basic pointers on PCB design. We initially tried using the schematic software for the PCB manufacturer that is capable of producing our board within our time constraints, but this proved futile, as it did not contain

even some of the most basic components in its meager component library, and it was not clear on the program how to design them. After realizing this, we went straight to PCB design and skipped over the schematic portion of the PCB design software.

We designed the LED driver and the bypass circuitry for our pedal. We decided on a tri-color LED for the power indicator, to display which functions of the pedal are active to the user. The LED will be off when the pedal is off entirely, when both the distortion circuit and the equalizer are turned off. The LED will be green when just the distortion circuit is on, red when just the equalizer is turned on, and blue when both the distortion stages and equalizer stages are turned on. This functionality is accomplished using 3PDT switches, logic gates, and transistors.

Our project is becoming closer to the final product. Features can be distinguished out of our design that do not exist in any other single pedal of similar types in the market today. These features include switchable 10-band equalization that can be toggled independently from the distortion, and a unique LED indicator that displays what mode of operation the pedal is in to the user. We have also included industry standard features for high-end effects pedals, such as true-bypass so that the pedal does not affect a guitar signal if it is located in a chain of pedals on a pedal board (a common configuration for pedals used by guitarists).

The next step will be to finish designing the PCB to contain the entire circuit, including all blocks, and then order the PCB. While waiting for PCB to arrive, we will start the design of a box to contain the circuit, and prepare information for the report.

We believe we are on schedule to complete on time, given our revised schedule as shown below.

Week 5: Circuit testing and PCB design, Order PCB

Week 6: Assemble entire circuit on PCB, design box for pedal, perform calculations for paper

Week 7: Buffer time/work on paper/final touches

Jacqui Richardson  
June-chi Hong  
Nathaniel Osgood  
Week 6 Progress Report

This week we finished designing the PCB for our pedal. We checked the schematic over several times. We found one misplaced capacitor and fixed it. Then we asked Pat about the placement of mounting holes on the PCB. He took us to the shop and showed us the different sized screws and standoffs we could use. After placing the mounting holes of the correct diameter, we sent the schematic to Express PCB to be made.

While waiting for the PCB to be delivered, June worked on desoldering the parts on the equalizer PCB, while Nate and Jacqui inspected the desoldered parts for damage and started gathering information for the final report. An outline of the final report has been completed so it will be easier to divide the sections amongst the group. We also ordered a 3PDT switch for the distortion.

We figured out the dimensions for our box that will house our final design. We decided on an aluminum case of dimensions 8"L x 4.25"W x 2.5"H. We will first design the box using AutoCAD. Once the box is designed, the file will be sent to the Mechanical Engineering Department in Higgins Hall where there is a machine that will make our box. There is enough scrap aluminum available, so our case will be free to make.

We are still on schedule and will be completing our design within the following week. This afternoon we will download the AutoCAD software and start designing the box. Our final PCB should be delivered by tomorrow and June will start soldering it. At the beginning of next week we will test and troubleshoot our final design, have the box made, and apply any finishing touches to our project.

Week 7: (Originally a buffer week); build and test our final design and complete the box; apply finishing touches to the project.



Nate Osgood  
June Chi Hong  
Jacqui Richardson  
Guitar Distortion Pedal MQP  
Week 8 progress report

In the past week we attempted to finalize our PCB assembly and ran into significant difficulties soldering the equalizer section. These problems were only further compounded when we attempted to fix them with our limited soldering skill, considering our team member who did most of our soldering is no longer in the country. We soldered the slide potentiometers for the equalizer block onto a perf board, and then crossed the wires to fix the problem we discovered last week of two of our potentiometer connections being backwards on every slide potentiometer in the equalizer block. We originally had pins soldered into the holes on the board because the potentiometer leads were too large to fit into the pads that we put in the board when designing it. These pins turned out to be a nightmare because we had to solder around the bottom of the board and there were far too many wires bent at ridiculous angles, which put pressure on solder joints and the wires themselves, and caused some of the wires to break while we were soldering the other ends, and everything was so close together that we didn't notice until we performed a functionality test, and noted that not all of the potentiometers were working correctly. In trying to fix this, we soldered and disordered these connections a few times, which only further weakened the wires and started lifting pads and damaging traces, due to our limited soldering experience. This functionality test also revealed that ten out of the twelve slide potentiometers in the equalizer block were functionally backwards, which was another issue with the PCB design.

In our testing yesterday, we also noticed an ungodly high-pitched squealing noise (note, not the desired high-pitched squeal of pinch harmonics, which this pedal reproduces perfectly). This noise occurred when we adjusted one of the potentiometers.

Thankfully Professor Labonté found us at the end of the day, and he led us to Bob the MANufacturing Genius, who is conveniently located upstairs next to the MQP lab and open practically 24 hours. After much bartering and many pelts exchanged, he agreed to completely save Nate's birthday (today, if you're reading this, wish Nate a happy birthday) and fix our problems. He also discovered some solder connections that needed reinforcing on the board. After assigning us some monkey work removing wires from the perf board we have the potentiometers soldered to, he touched up our board, cleaned flux off of it, repaired our broken pads (one of which was exploded, because Jacqui rocks at desoldering and we were getting really frustrated) and broken traces. He also fixed the equalizer potentiometer directions so that they are no longer functionally backwards. To top it off, he did all of this in about as much time as it took us to do the monkey desoldering work. He suggested that the squealing noise described above could have been caused by a dirty potentiometer. We believe that it is either caused by this, or a bad connection somewhere between the perf board and the PCB. We are going to track down this issue and fix it this week. We are also still waiting for the box, and then we will manually cut and assemble our PCB inside it. We have included a rough outline of our paper for your reading pleasure.

Nate Osgood  
June Chi Hong  
Jacqui Richardson  
Guitar Distortion Pedal MQP  
Week 9 progress report

At the beginning of this week we were waiting for a 3PDT switch to come in, so we worked on the outline for the paper and divided it up into sections for each person to work on. We emailed this to June in Taiwan so he could begin working on his sections of paper. When the switch arrived, we wired the bypass network and hooked up the LED driver circuitry.

When we tested our LED circuitry, we discovered that it worked but it was far too dim. The next logical thing to test was the voltage being supplied to our LEDs when they were supposed to be on, and we found that our 4.5V “rail” was really a 4.5V *reference*. This was quite a mistake. Our 4.5V reference was set by a simple voltage divider consisting of two resistors in series. This serves fine as long as you’re not loading the 4.5V point (such as trying to drive an LED and power ICs with it, like we were). Thanks to Professor Bitar for pointing this out for us. We have run into Professor Bitar a few times and he has been very helpful each time, he also discovered a polarized capacitor in the voltage reference block that was soldered in backwards and was about to rupture, and wasn’t functioning properly (polarized capacitors in backwards function as resistors). We have since fixed this.

We fixed the 4.5V reference issue by cutting the trace that connects the reference point to the LED driver circuitry and the LED, and replacing it with a 5V LDO. This takes the load off the reference point, as it is now only biasing an operational amplifier in our distortion block. This LDO can supply up to 150mA, which is far more than we need for our purposes. Future production of this pedal would likely use the other operational amplifier on the IC used in the

distortion block as a buffer to prevent the reference point from being loaded. This could be implemented via PCB modifications.

Once we implemented our new design, the LEDs were “super bright” as advertised (we got them from [www.superbrightleds.com](http://www.superbrightleds.com)). We tested the pedal and it was making a kind of phasor-like sound that seemed to be sweeping in frequency. We are not entirely positive what it is from, but it could be extra noise created by all the extra wires that are connected to the board from the bypass circuitry. These wires should stop acting as antennae after the circuitry is in the box.

The distortion block is no longer working properly. When switched on, you can hear the distortion but there must be an intermittent connection somewhere in the several wires we have attached now or maybe something on the board itself is partially connected. We’ve checked out a few things and Bob has reinforced them, but we cannot currently get an output out of our distortion block. The equalizer and the bypass functionality work perfectly. Fixing this issue is going to involve long hours of cleaning the board and testing every single connection in between parts that work. It’s going to be a nightmare.