

AO-A187 005

AN INTRODUCTION TO MILITARY SATELLITE COMMUNICATIONS
(U) ROYAL SIGNALS AND RADAR ESTABLISHMENT MALVERN
(ENGLAND) T C TOZER APR 87 RSRE-MEMO-3976

1/1

UNCLASSIFIED

F/G 25/5

NL

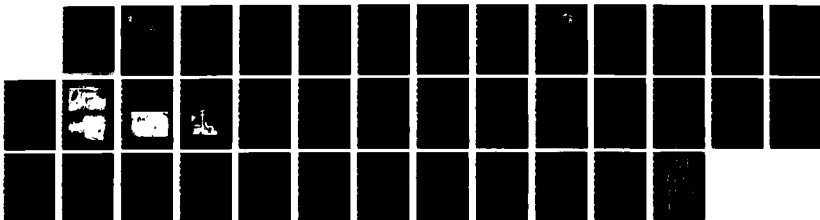

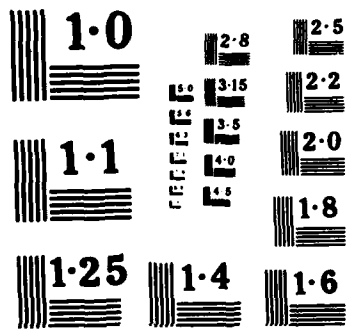



AD-A187 005

RSRE
MEMORANDUM No. 3976

ROYAL SIGNALS & RADAR ESTABLISHMENT

AN INTRODUCTION TO MILITARY SATELLITE
COMMUNICATIONS

Author: T C Tozer

PROCUREMENT EXECUTIVE,
MINISTRY OF DEFENCE,
RSRE MALVERN,
WORCS.

APPROVED FOR RELEASE
BY THE
PROCESSED BY THE
INFORMATION

DTIC
ELECTE
NOV 25 1987
S H

8711 10 120

RSRE MEMORANDUM No. 3976

ROYAL SIGNALS AND RADAR ESTABLISHMENT

Memorandum 3976

TITLE: AN INTRODUCTION TO MILITARY SATELLITE COMMUNICATIONS
AUTHOR: T C TOZER
DATE: APRIL 1987

SUMMARY

This memorandum outlines the principles of military satellite communications. It examines the philosophy of system design, and the state of the art in both space and ground segments. Some current UK equipments, including SKYNET 4, are described by way of illustration. The report is aimed as a broad tutorial introduction to the field, emphasising in particular those areas where Milsatcom differs from its civilian counterparts.

L. Cooper D. Smith

DTIC
COPY
INSPECTED
1

| | |
|---------------------|-------------------------------------|
| Accession For | |
| NTIS GRA&I | <input checked="" type="checkbox"/> |
| DTIC TAB | <input type="checkbox"/> |
| Unannounced | <input type="checkbox"/> |
| Justification | |
| By _____ | |
| Distribution/ _____ | |
| Availability Codes | |
| Dist | Avail and/or Special |
| A-1 | |

Copyright

C

Controller HMSO London

1987

AN INTRODUCTION TO MILITARY SATELLITE COMMUNICATIONS

by

T C Tozer

CONTENTS:

- 1/ Background
 - 2/ Military Application
 - 3/ Frequency Bands
 - 4/ Satellites
 - 5/ Traffic and Terminals
 - 6/ Link Budgets and Multiple Access
 - 7/ Threats and Countermeasures
 - 8/ Future Trends in Milsatcom
 - 9/ Brief Conclusions
- References
- Appendix (Link Budget Illustrations)

1 BACKGROUND

Military satellite communications (MILSATCOMS) have been well established for a number of years, and are major features of US, UK, French, Nato and Warsaw Pact communications systems. They are significant in terms of both current investment and associated research and development activities: there is little doubt that military programmes have helped to maintain the commercial industrial base, and in many ways military systems lead the field in terms of technology development and sophistication.

This report attempts to outline system design philosophy and those features which distinguish Milsatcoms from civil systems. Clearly, there are many aspects it is not possible to describe here in detail. The views expressed are those of the author, and do not represent any official policy.

The principal characteristic of Milsatcom is its varied nature: it needs the ability to cope with a wide variety of users, traffic, and scenarios. Thus it encompasses both high-capacity fixed links and low data-rate mobile traffic (often called the Strategic and the Tactical elements). Also, many parts of the system may be required to operate in hostile environments, and will be designed to withstand threats such as jamming.

In the UK, Milsatcoms got off the ground in 1969, with SKYNET 1 (the world's first geostationary defence communications satellite), followed in 1973/4 by the SKYNET 2 series. These satellites operated at SHF (8/7 GHz), and each spin-stabilised satellite provided two wide bandwidth channels, with a single 16 W travelling-wave tube amplifier; earth coverage was provided by a simple de-spun horn and plane reflector. The satellite design was based on the INTELSAT III bus, and one SKYNET 2 satellite is still operational.

The UK programme revived in 1981, after a lull, with plans for the SKYNET 4 programme. This calls for an initial 3 satellites (Phase I), and the first launch had been planned for June 1986; it now looks likely that this may take place in 1988 with ARIANE. A subsequent phase of the SKYNET 4 programme is envisaged for the early 1990's, and thoughts are already being given to new system designs (SKYNET 5) for later years.

As with civil systems, Milsatcom systems include both space and ground segments, with a range of associated ground terminals, and other ground facilities for Telemetry Tracking & Command (TT&C). Because of the need to operate with existing equipment ("backward compatibility"), and with the vagaries of defence procurement processes, radical changes in system design tend to occur only slowly.

The demands for military usage of Satcoms are continually increasing. This is due partly to increased requirements for communication (especially from small terminals) in the face of enemy threats, and partly to enhanced end-user complexity (eg computers and sensors exchanging quantities of digital information). Such usage may be regarded as part of "C³I" - "Command, Control, Communications & Intelligence". One interesting current development is the planned US MILSTAR programme^[1], using EHF and spread-spectrum techniques to provide a highly secure service to a select community of users.

2 MILITARY APPLICATION

Satellite communication is attractive to the military principally because of its wide coverage area, which permits operations at short notice in virtually any part of the world, without reliance on a national communications infrastructure. The traditional carriers of HF and VHF/UHF suffer from major weaknesses of unpredictable propagation and limited range respectively, and Satcoms provide 'high availability' by comparison. Additionally, the bandwidth (BW) and capacity offered is considerable (typically 100's of MHz @ SHF). A disadvantage however is that the satellite itself is highly visible to an enemy, and links may be subject to intercept or disruption. Because of the overall need for survivability and redundancy, military networks generally aim to use several different modes of communication, and Satcoms may be simply one overlay dimension of (say) a data network with UHF radio links and fibre-optics also employed. For many tactical scenarios however, Satcoms may represent the only viable means of communication.

Milsatcoms prove attractive for both large fixed links and small portable or mobile links, and are employed by all three armed services. Consequently there is a variety of data rates, modulation schemes, terminals and modems in use, all of which may need to be accommodated over a common satellite; this leads to considerable complexity in planning & allocation of accesses (eg terminal frequency & power). Bearing in mind the added difficulties of co-ordinating users who may be operating in adverse environments (perhaps under enemy threat), we see a motley community of users who are unlikely to be as well controlled as, say, a PTT civil system. Interoperability between different networks & systems, and flexible & responsive Access Planning represent major demands in Milsatcom.

3 FREQUENCY BANDS

Milsatcoms operate currently in the UHF and SHF frequency bands, while EHF and Optical frequencies are becoming of increasing interest (see 8.2, 8.3). These frequencies are not universally recognised as the exclusive prerogative of the military, although the SHF and EHF bands are generally accepted in this way. Circular polarisation is commonly used in all bands, but frequency re-use through polarisation diversity is not commonly employed in Milsatcom, as the large dynamic range of signals could well exceed any cross-polar discrimination. The band characteristics may be summarised:

UHF: Generally in the range 220 - 400 MHz, and hence shared with a variety of terrestrial systems (including TV). Helix antennas are commonly employed, both on the ground and the satellite; these are physically very large, and represent a major size and mass penalty. Directivity is limited, for both ground station and satellite antennas, (making it difficult to achieve a smaller satellite coverage area than full "Earth cover"). For these reasons, UHF Satcoms are relatively vulnerable to interference or jamming, compared with higher frequencies. Frequency re-use between mutually visible satellites is not normally possible. In order to allow operation of more than one satellite without interference (and potential power capture by unwanted signals), UHF transponders are generally narrow-band with a single channel of a few kHz assigned to each; one consequence is that the satellite front-end thermal noise is much less than for a wideband transponder.

The attraction of UHF lies in the cheapness and simplicity of the ground equipment, and it is popular both with ships, and with submarines which may require rapid erection of a simple antenna just above the surface.

SHF: This employs uplink in the range 7.9 - 8.4 GHz, and downlink 7.25 - 7.75 GHz. Part of the band is allocated exclusively to Satcoms, (but not to Milsatcoms). However, interference from other users is not generally a problem since practical ground antennas possess reasonable directivity (eg a 1.7 m dish antenna has a beamwidth of 1°). This also permits frequency re-use by other satellites within the geostationary arc, although the limits of capacity are now being reached. Transponders are generally transparent and wideband (10's of MHz BW), carrying a number of channels simultaneously, and SHF carries the bulk of military Satcom traffic. A translation frequency of 725 MHz has been traditionally used, although this does not optimally match the up- and down- link bands.

EHF: Uplink 43.5 - 45.5 GHz, downlink 20.2 - 21.2 GHz (and possibly also 39.5 - 40.5 GHz). This is only beginning to emerge for operational use, but considerable future application may be anticipated in Milsatcom - see 8.2.

4 SATELLITES

The majority of military communication satellites are in geostationary orbit. While obviously convenient, this provides limited coverage of extreme latitudes, which is a weakness (regions such as Northern Norway are of special military interest). For many years, the Russians have used highly inclined elliptical orbits (Molniya) for polar region coverage, where three satellites may each provide 8 hours coverage per day, with virtually overhead elevation. Fig 1 shows views of the earth from (a) a geostationary satellite at 0° longitude, and (b) a Molniya orbit satellite at apogee above Greenwich, making apparent the coverage advantages. The disadvantages of Molniya orbits are: the need for three satellites; increased orbit decay (and hence shorter satellite life); increased satellite fuel requirements; and greater environmental radiation levels. Such an approach has not been adopted by the West, although slightly inclined geostationary orbits have been proposed to improve Northern latitude coverage. Geostationary military satellites tend to have less stringent station-keeping requirements than civil satellites; east-west station keeping is typically 0.1°, and active north-south station keeping may not always be used.

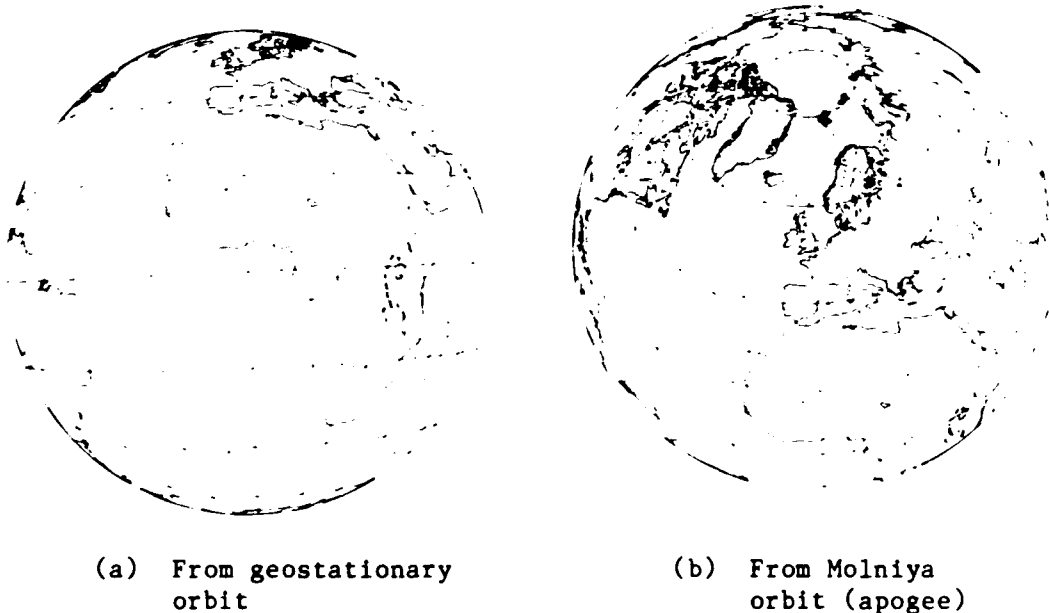

Fig 1 Satellite's view of the earth

Military communication satellites are similar to their civilian counterparts in using transparent transponders, but they also tend to incorporate features to provide protected communications under jamming threat, such as special antennas and spread spectrum processors (see 7.5, 7.6). Additionally, they may be hardened against nuclear effects (7.2), and employ secure encrypt/decrypt coding for TT&C.

Earth coverage antennas are generally used where possible, to provide a service over the widest area (military deployments tend to be unpredictable in their location). In order to permit operation with small terminals, high-gain spot beam antennas are also needed, and this represents a conflict with the wide coverage requirements. Some advanced satellites may employ steerable spot beams, with either mechanical steering, Multiple Beam Arrays, or phased array steering; such solutions however are neither straightforward nor cheap.

Transparent transponders tend to be used for the bulk of traffic. Greatest flexibility is achieved in this way, allowing usage by a wide range of terminals. Design aims include highly linear amplifier stages and good AM-to-PM conversion performance, to help to minimise intermodulation products and other effects due to multiple accesses and/or any jamming signals. Fig 2 shows a functional outline of an SHF transparent transponder, where the uplink passband is amplified, selected by filtering downconverted (single conversion), and transmitted via a Travelling Wave Tube Amplifier (TWTA) together with further filtering (to remove images, intermodulation products etc). The channel amplifiers would have commandable gain steps, allowing the system operator to choose required back-off from limiting (ie saturation) mode, and transponder gain would usually be sufficient to permit saturation on front-end thermal noise if required.

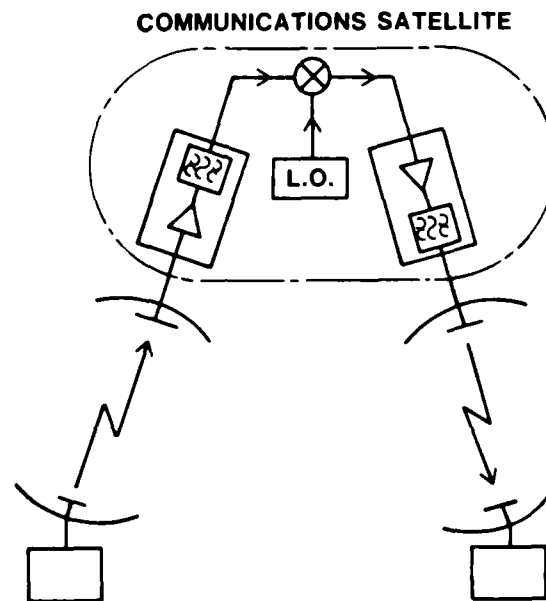

Fig 2 Transparent transponder: - simplified functional outline.

A typical military satellite is illustrated by SKYNET 4. The SKYNET 4 system^[2] aims to provide flexible communications for Maritime and Land forces, together with fixed strategic services. Among its major design features are:

- * Multifrequency capability, ie operational UHF and SHF service;
- * Survivability, ie hardening against Nuclear EMP, also anti-jamming features providing resistance to Electronic Countermeasures (ECM);
- * Operational flexibility, ie selectable antennas, channels and gain steps to optimally support a varying user community;
- * Long service life: - the operational design lifetime is 7 years.

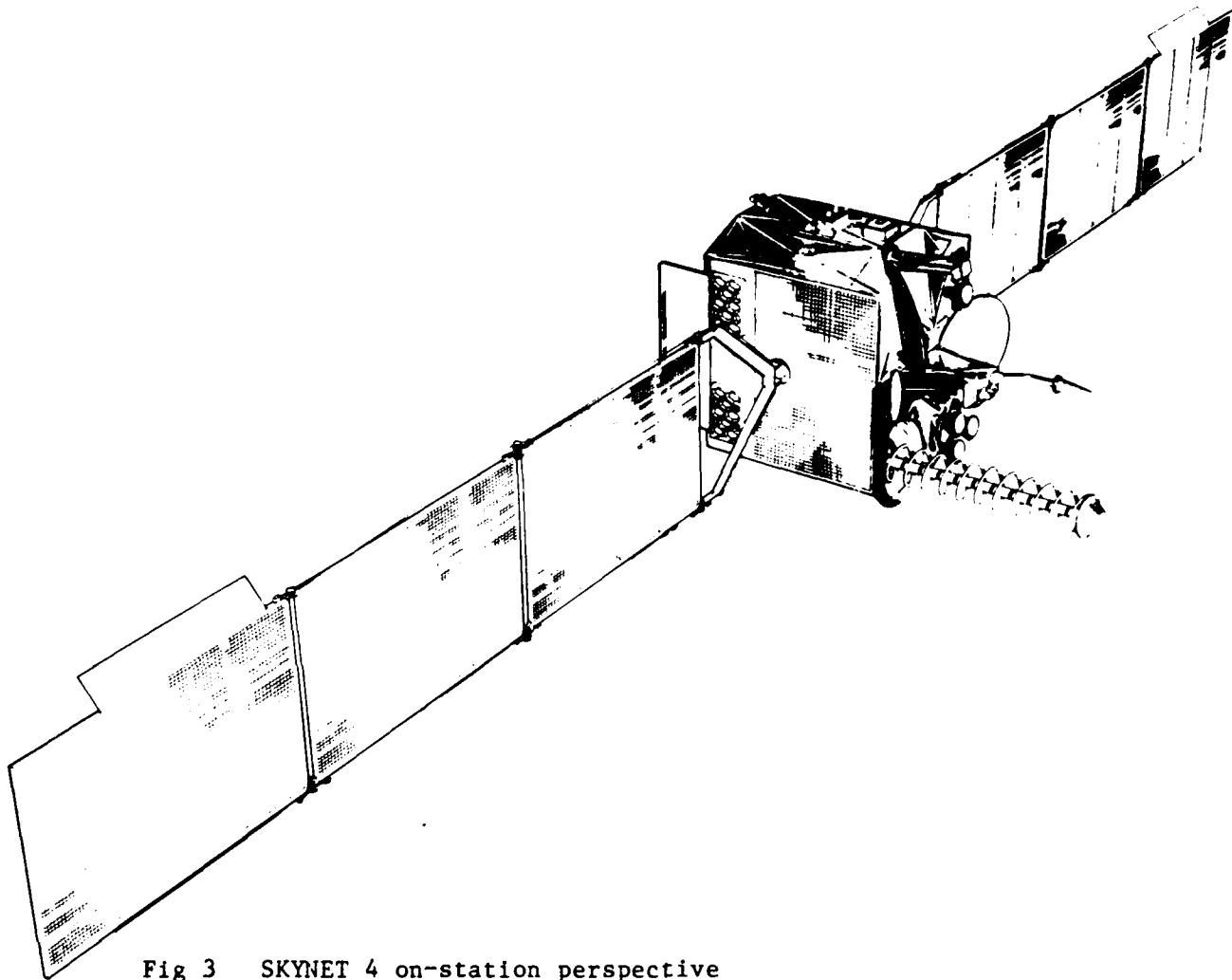

Fig 3 SKYNET 4 on-station perspective

The on-station characteristics of the spacecraft are:

| | |
|--|--------------------------------------|
| Spacecraft dry mass | 670 kg |
| East/West station keeping (no active N/S station keeping) | +/- 0.1° |
| Momentum wheels | Two @ 25 Nms One @ 16 Nms |
| Hydrazine Thrusters | 0.7 to 20 N |
| Pointing Accuracy: Roll & Pitch | 0.07° |
| Yaw | 0.35° |
| DC Power supply | 1600 W nominal 1200 W end-of-life |
| Voltage range | 42.5 - 30 V |
| Telemetry channels & commands | approx 500 |

The SKYNET 4 satellite is 3-axis stabilised, and is based upon the successful ECS design, with a Service Module and a Payload Module. British Aerospace are the prime contractor, and the payload is built by Marconi Space Systems. The design may be engineered for launch into geostationary orbit either by Ariane or by the Shuttle with boost into transfer orbit by payload assist module PAM D-2. In-orbit control is based on a momentum-wheel bias system coupled with sun and earth sensors. Lightweight carbon fibre materials are used for many structural parts. The power supply is regulated in sunlight, and unregulated in eclipse.

The first phase of the SKYNET 4 programme calls for three satellites, the first to be placed at 1°W, the second at 6°E, and a spare over the Indian Ocean. Fig 3 shows an on-station perspective of the satellite: note the complexity of the antenna 'farm'.

An outline of the SHF payload is shown in Fig 4. The SHF amplifier technology is based on GaAs FETS, with a receive noise temperature of 1000 K, and 40 W TWTA's for the output stages. Four SHF channels are provided, with BWs ranging from 60 to 135 MHz, and single conversion is employed with a translation frequency of 725 MHz. The uplink antenna is an Earth-cover TE₁₁ mode corrugated horn in all cases, except where a spot beam is selected (to give higher gain).

There are a variety of transmit antenna options, with separate higher gain offset-fed reflector antennas serving to concentrate the transmit power over smaller regions, to provide increased capacity with small terminals. In addition to Earth cover, the Wide beam antenna serves interests in the North Atlantic region, the Narrow beam serves the European area, and the Spot beam provides a high EIRP over central Europe, (specifically to serve small Manpack and other tactical army terminals). The specified required coverage regions are shown in Fig 5.

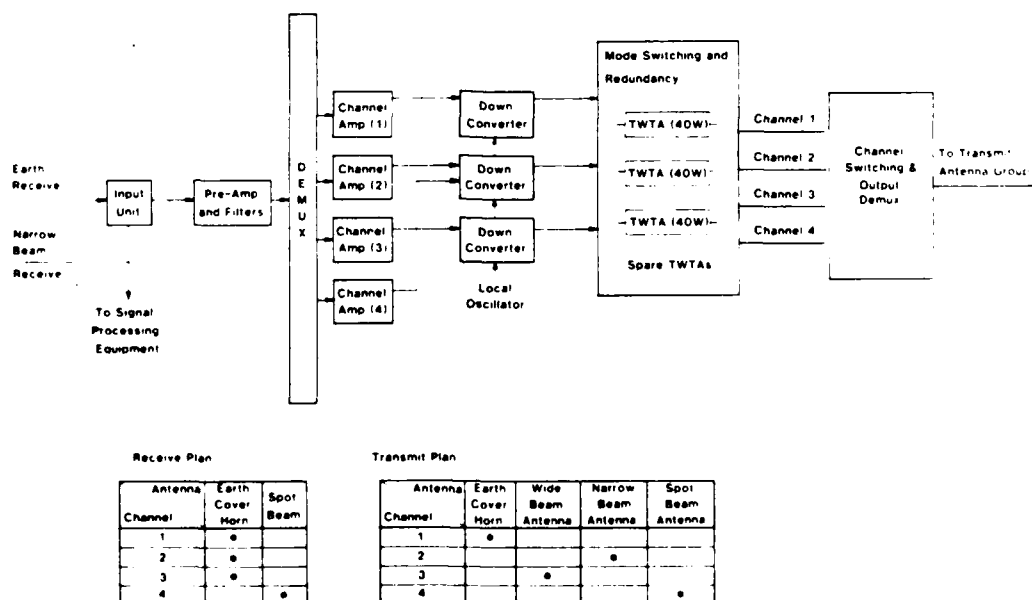

Fig 4 SKYNET 4: SHF payload simplified outline, and antenna plan.

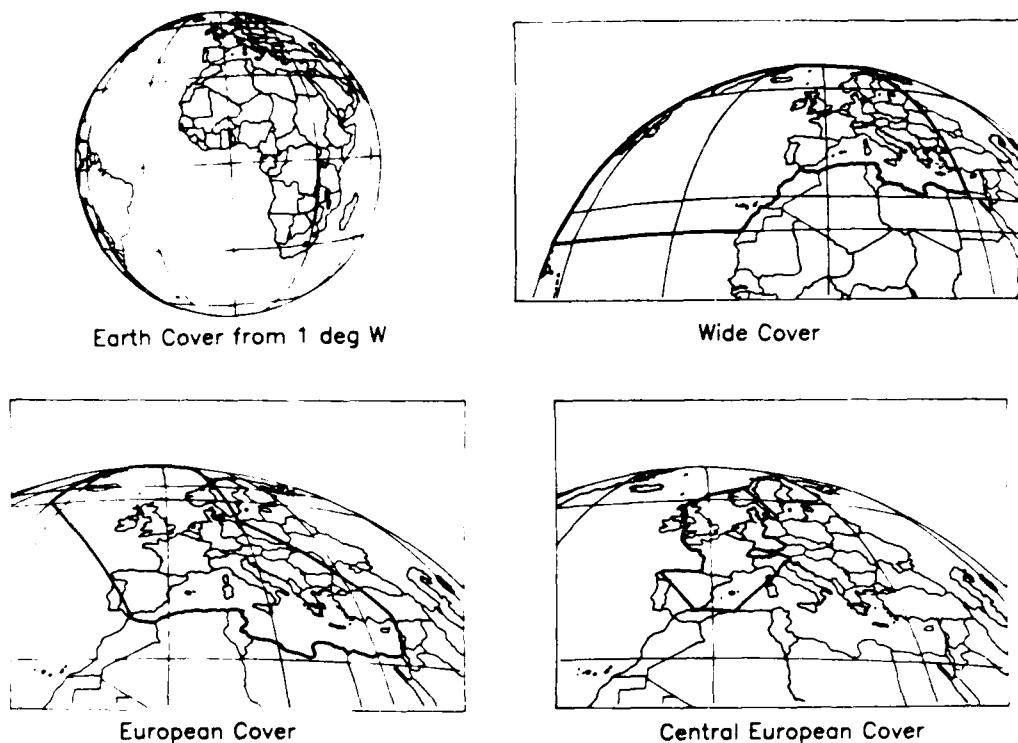

Fig 5 SKYNET 4: Specified coverage areas.

The SKYNET 4 antenna plan is also shown in Fig 4, and the channel parameters are summarised below, illustrating the increased downlink EIRP as the coverage area is reduced in size:

| <u>Channel</u> | <u>BW</u> | <u>Transmit coverage</u> | <u>EIRP</u> |
|----------------|-----------|--------------------------|-------------|
| 1 | 135 MHz | Earth Cover | 31 dBW |
| 2 | 85 MHz | Narrow Beam | 34 dBW |
| 3 | 60 MHz | Wide Beam | 35 dBW |
| 4 | 60 MHz | Spot Beam | 39 dBW |

A Beacon transmission is provided at SHF, from a solid-state transmitter. It feeds an Earth cover antenna, and may be used by terminals for acquisition and tracking. The SHF payload incorporates several filter units: these include bandpass filters to prevent intermodulation products from multi-carrier signals in one channel falling into adjacent channels, bandstop filters to reject interfering signals at the beacon frequency, bandstop filters to reject transmitted noise and intermodulation products at the receiver frequency, and low pass filters to reject TWTA harmonics.

Two UHF channels are available, each with 25 kHz bandwidth, and operating within the band 305 - 315 MHz (uplink), 250 - 260 MHz (downlink). A common helix antenna is used for both transmit and receive, with a multiplexer unit separating the two. This antenna is relatively large (2.4 m length), and is deployed once the satellite is on station, yet it provides only Earth coverage. The UHF transponder is all solid-state, with each channel delivering 40 W of RF power, and an EIRP of 26 dBW. Receive G/T is -18 dB/K.

An experimental EHF receiver is a feature on SKYNET 4. Operating in the 43 to 45 GHz band, this is an advanced R&D package, originally funded by RSRE as a step towards the future exploitation of the EHF bands (see 8.2).

A self-contained spread-spectrum on-board receiver provides communication facilities at SHF with protection against jamming. A Nulling Antenna facility is also provided for use with the SHF payload.

This complex payload may be reconfigured by telecommand, for example to change the SHF antennas. Reliability is a major requirement, and there is considerable redundancy and associated redundancy switching, to allow for substitution of failed units. There are extensive associated telemetry and telecommand systems, supported by dedicated computer facilities in the ground segment.

Because SKYNET 4 aims to provide facilities for all three UK armed services, it is necessarily complex: if a greater number of satellites were provided, each dedicated to a particular user community (as is more common in the US), each might be somewhat simpler. In particular, the close proximity of a number of antennas on the satellite give potential problems of electromagnetic compatibility (EMC), and represents a major design challenge.

5 TRAFFIC, TERMINALS & LINK BUDGETS

5.1 Traffic.

Military communications traffic may be categorised as 'Strategic' or 'Tactical'; with the former generally related to large and fixed terminals, and the latter to small and mobile terminals. (This terminology is usually extended to the terminals themselves, even though both types of traffic may be handled by all terminals). Strategic traffic (at SHF) is handled in a way similar to civil traffic, and is likely to be high-speed data or PCM-TDMA speech. The traffic patterns and routing requirements may however be less predictable than in a civil scenario.

Tactical terminals are of major importance to the military, and their usage differs from most existing civil applications. The number of small terminals deployed may be very much greater than the number of large terminals, and each is essentially independent with Single -Channel -Per -Carrier (SCPC) transmission. Their capacity is limited, and traffic may be a combination of a few data and speech channels. Data is often telegraph (ie teleprinter) @ 50 or 75 baud, several channels of which may be simply multiplexed, prior to transmission, into a higher data rate. Other forms of data may include transfers between battlefield computers and sensing devices, or slow-scan television.

Speech in military systems is generally in digital form, and this permits the use of encryption devices when required. Two forms of speech traffic are common: 2.4 kbit/s vocoded speech, and 16 kbit/s CVSD.

Vocoded speech @ 2.4 kbit/s can be provided by a range of encoders (or 'Vocoders'), which with modern IC technology can be acceptably small. There are several schemes currently employed, but the most promising seem to be those using some form of LPC ("Linear Predictive Coding"). Vocoders of this type produce a model of the vocal tract which is periodically updated; the parameters of this model are transmitted over the channel and used to drive a

voice synthesiser which is essentially a transversal filter fed by a pulse stream at the pitch rate. There are other forms of channel Vocoders, which essentially split the speech spectrum into narrow frequency bands and transmit their amplitudes.

Such systems however may not be very tolerant of errors (because of the high information content per bit, and the structured format), and a channel bit error probability (P_e) around 10^{-3} is usually required; if cryptographic encoding is also used, then requirements may be even more stringent because of 'error extension'. 2.4 kbit/s vocoded speech has been used traditionally by the Navy, where its narrow BW suits HF radio channels.

CVSD ('Continuously Variable Slope Delta modulation') is a simple form of adaptive Delta modulation, akin to 1 bit differential PCM. It has the merit of tolerance to relatively high bit error rates (P_e around 2% may still be intelligible, although the use of encryption devices may again worsen the situation). Furthermore, voice recognition is superior to vocoded systems, as is the tolerance to background noise. 16 kbit/s CVSD is common in army communications, (being applied mainly to UHF portable radios where simple lightweight encoders may be mass produced).

5.2 Modulation.

A variety of carrier modulation schemes are used in Milsatcom. The choice of these may be partially dictated by the need for operation in a suitable multiple-access scheme, or in conjunction with some form of spread spectrum (see 7.6). It is generally important that signals are constant-envelope within a transponder, suggesting the use of PSK or FSK rather than ASK. Binary PSK (BPSK) and 4-phase PSK (QPSK) are commonly used, together with variants of these which marginally improve upon BW and envelope characteristics. In general, it is power rather than BW which is at a premium in Milsatcom, and this leads to the use of FSK (binary or multi-level, eg 16-level MFSK), with the added feature that phase coherence is not required between symbols (which may be difficult with Frequency Hopping Spread Spectrum - FHSS).

5.3 Coding.

Error-control coding is widely used, and is a feature of most modem designs. It helps maintain high integrity for data communications and speech links, and may also provide link power benefits. However, given that speech links may be working at relatively high error rates (and also be subject to propagation fading), the overall benefits of FEC (Forward Error-correction Coding) in terms of power budgets may not always be as high as at first sight. Coding is particularly important for Frequency Hopping Spread Spectrum (FHSS) links, where interleaving maintains integrity over the duration of jammed hops, and advanced spread spectrum modems may employ combinations of coding schemes, for example Convolutional and Reed-Solomon codes.

It is a requirement of Milsatcom that some links should survive under heavily jammed conditions, where adverse link budgets permit data throughput of perhaps as low as only a few bits/s. There are considerable difficulties in dealing efficiently with such very low data rates, and besides the judicious use of coding, attention must be given to constraints of Doppler effects, of drift, and of phase noise caused by oscillators both in the satellite and on the ground.

5.4 Terminals.

Milsatcom systems employ a variety of terminals, ranging from large fixed stations to smaller portable or mobile terminals. Each Milsatcom system will include one or more main base or 'anchor' stations, and these serve as an interface between satellite traffic and fixed networks, as switching and routing centres, and are generally co-located with TT&C facilities and the system control & operational staff.

The feature distinguishing these anchor stations from their civilian counterparts is that they generally handle many different types of traffic, and use a variety of types of modems with a mixture of multiple access schemes. In other respects, they may be very similar to civil stations, with SHF antennas of diameter 20 m or more, and with transmit powers of a few 10's of kW.

Anchor stations provide local loopback facilities (at baseband or IF) to permit communication between small Satcom terminals, which would otherwise generally not be possible directly due to power constraints. They also provide patching and switching connections to a variety of terrestrial networks, using cable, fibre-optic and microwave links. This ground segment alone can represent a very considerable investment and complexity (at least as great as that of procuring and launching a satellite).

Besides a few such large stations, a range of smaller fixed terminals may be employed, to handle traffic at military centres. The majority of their links will be to or from an anchor station, but some such terminals may also possess sufficient EIRP to communicate directly with one another, or with small tactical terminals.

Land tactical terminals come in a variety of sizes, being transportable by a vehicle, by air-drop, or by a soldier. A typical such terminal is the UK TSC 501, which is transported in a Land Rover, and may be erected within a few minutes. This has a 1.7 m dish, and a TWTA giving 60 W, to provide one or two speech channels and telegraph channels with PSK modulation; multiplexed data channels may also be used. It is shown in Fig 6. A similar terminal is the UK TSC 502, which is also intended for rapid deployment, and may be air transportable; see Fig 7.

A smaller terminal is the UK portable "Manpack", with a 45 cm dish, providing 50 baud telegraph together with analogue speech (and, potentially, digital speech if operating in a satellite spot beam). See Fig 8. Such highly portable terminals are extremely useful to land mobile forces, but have the disadvantage that a high proportion of satellite EIRP is required to support each downlink transmission. This is a driving force towards the use of spot beam satellite antennas for some scenarios.

Land mobile terminals are also of importance, and may be used on tanks and other military vehicles. Their application is restricted primarily by constraints on antenna mounting.



Fig 6 UK Portable SHF Satcom Terminal TSC501

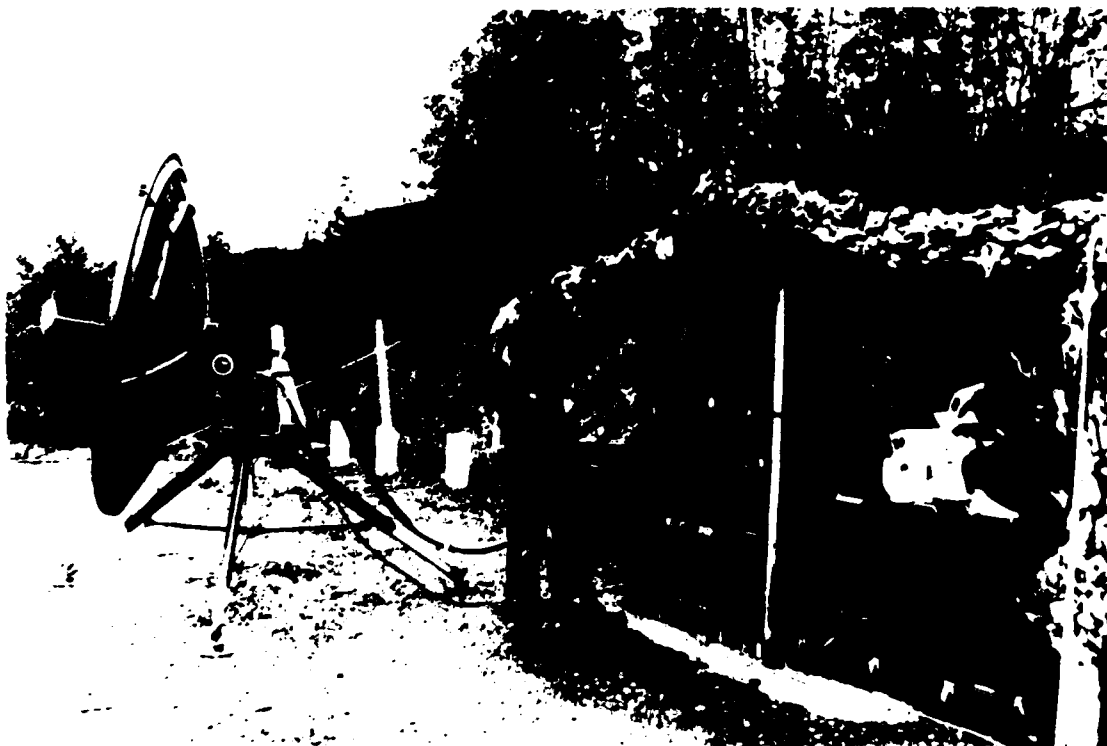

Fig 7 UK Portable SHF Satcom Terminal TSC502

An interesting description of the development of the prototype Manpack is given in [3]. The parameters of this prototype may be summarised:

| | |
|------------------------|--|
| Terminal size | 45 cm x 45 cm x 20 cm plus back carrier |
| Weight | 17 kg including batteries and telegraph terminal |
| Max EIRP | 31 dBW |
| Antenna dish diameter | 45 cm |
| Antenna gain | 28.5 dB @ 8 GHz |
| Antenna beamwidth | 6° approx |
| Receive G/T | 2 dB/K |
| Receiver Noise Temp | 400 K at antenna feed |
| Traffic | 50 baud telegraph or analogue speech |
| Modulation (telegraph) | differential BPSK |
| BER @ 50 baud | better than 10^{-4} |
| Target set-up time | 2 minutes |



Fig 8 "Manpack" SHF Satcom Terminal

Ships are prime users of Satcoms, and have traditionally used both UHF and SHF Satcoms. The exploitation of EHF is also of current interest, largely as it can provide better AJ and Intercept (LPE) performance (see 7.6, 7.7, 8.2). Many ships require to relay data from weapons systems, together with speech traffic, which in the Navy is generally 2.4 kbit/s vocoded. At frequencies above UHF, ship motion makes Satcom antenna pointing demanding; installation space is also at a premium, and parts of the superstructure may block the field of view; this blockage is known as 'Wooding'.

As an example of a ship terminal, the UK SCOT system uses two antennas, one either side of the mast, to alleviate wooding. These are contained in weather-protecting radomes, as shown in Fig 9. The SHF dish size is of the order of 1 m. Larger antennas could be employed if data requirements demand, but these would be subject to the limits of ship motion and the cost constraints of highly stabilised platforms.

Submarines require to maintain a low profile, and to remain submerged whenever possible. This leads to their use of UHF, with a simple antenna deployed above the surface for short periods, as small SHF antennas are not practical. Future developments in small EHF antennas may be foreseen, and there is also interest in optical communication, where blue-green lasers may penetrate seawater (see 8.3). To minimise detection, message durations are usually kept as short as possible.

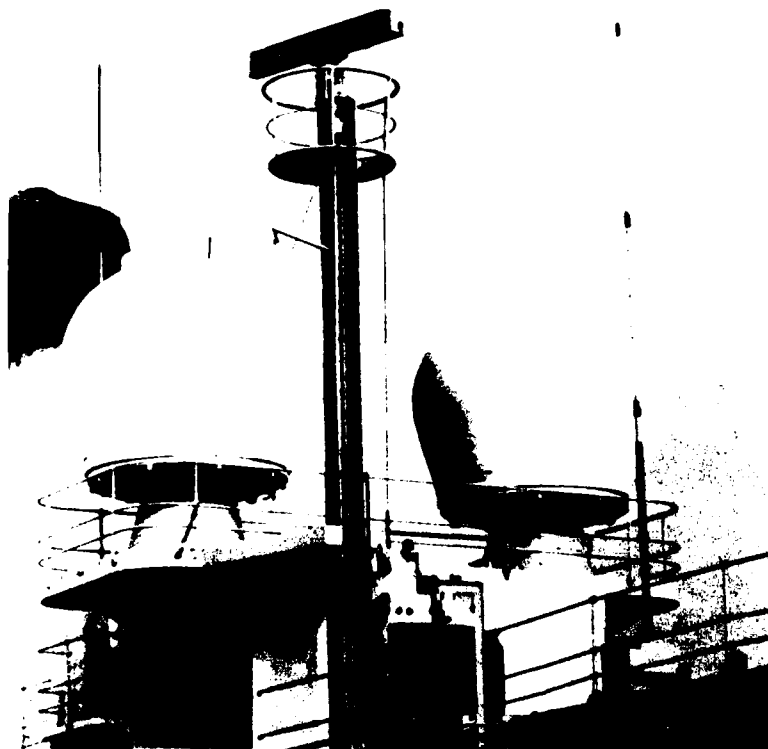

Fig 9 "SCOT" Navy Satcom Terminal

Aircraft Satcoms are less well developed. There are increased problems here of antenna pointing & stabilisation, and doppler shift. For high-speed fighter aircraft these problems are severe. Potential outages may also occur due to path obstruction while manoeuvring. Antenna size is severely constrained on an aircraft, and values of receive G/T as low as 0 dB/K (at SHF) may be typical. The UK MASTER demonstrator programme^[4] aims to prove the practicality of SHF Satcoms to Nimrod aircraft.

6 LINK BUDGETS & MULTIPLE ACCESS

6.1 Link Budgets.

The performance and capacity of any satellite communications system is largely dependent upon the link budgets. The wide variety of simultaneous links through a shared transponder, together with the fact that the majority of military links are power (rather than BW) limited, distinguishes most military from civil systems. It is generally downlink EIRP which is at a premium, and for each small terminal user there is a potential trade-off between power, antenna size, and achievable data rate. An understanding of link budgets is thus crucial to military Satcoms designers, planners, and operators.

Transponders may be operated either in backed off mode, or close to saturation. In the former case, the satellite downlink output powers will be strictly pro rata the input powers (together with front-end thermal noise), and in the saturated mode the fixed output power (eg 40 W TWTA) will be apportioned between downlinks according to their relative uplink powers together with any small signal suppression effects.

Small Signal Suppression (SSS) arises when more than one signal share a common limiting (ie saturating) amplifier. The analysis of this non-linear situation can be very complex, especially where several signals are concerned. There are two simple extreme cases however:

- (i) A single carrier signal whose power is far below accompanying wideband gaussian noise: the carrier suffers additional SSS of 1 dB over and above the pro rata power apportionment between the signal and the noise.
- (ii) A single carrier signal in the presence of another much higher power carrier (eg a CW jammer): here the signal suffers additional SSS of up to 6 dB. (This may be intuitively visualised by looking at a phasor diagram with the sum of a large and a small signal subject to constant magnitude).

Front-end thermal noise must be included among the input power levels: some uplink accesses may be operating well below the power levels of others, or even below the total transponder noise power, ie with an overall negative signal-to-noise ratio (SNR) in the transponder BW. Thus with uplinks from the smallest terminals alone, we may find that the satellite downlink power comprises mainly thermal noise! In practice a transponder will carry many signals with a wide dynamic range. The power taken by intermodulation products needs to be accounted for, together with any jamming power.

It can be easily seen that the capacity of small terminals is very limited, and that they may require a significant proportion of available satellite EIRP in order to operate. In the Link Budget Appendix to this report some typical illustrative link equations examples are developed, to demonstrate system limitations.

6.2 Link Margins.

Suitable margins must be included in link equations to provide for the effects of propagation loss, antenna pointing, and engineering implementation etc. These will depend upon the frequency band, area of operation (including the weather and the elevation angle to the satellite), and type of terminal. In general military systems are not as controllable or as predictable as their civil counterparts, and larger margins are taken. One need only envisage a soldier operating a small terminal under hostile conditions in a battlefield environment to appreciate that niceties of fraction of a dB are academic.

Some typical practical single path margins, for moderate elevation angles, might be:

| | | |
|------|------|---|
| UHF: | 1 dB | (considerably more if multipath fading) |
| SHF: | 3 dB | |

At EHF, attenuation is very critically dependent upon the weather and the elevation angle, and margins have to be specified in these terms. Ref [12] illustrates some typical values. In a moderate climate, EHF margins may be little greater than for SHF, provided it is not raining! In certain wet climatic regions however the following figures might be an example:

| | | |
|---------------|-------|-------------------------|
| EHF (20 GHz): | 3 dB | (for 95 % availability) |
| | 8 dB | (for 99 % availability) |
| EHF (44 GHz): | 10 dB | (for 95 % availability) |
| | 20 dB | (for 99 % availability) |

In any band, the margin may require to be increased by perhaps 6 dB if low elevation angles mean that the terminal beamwidth encompasses a reflecting surface (ground or sea).

6.3 Multiple Access Techniques.

A Milsatcom transponder may require to handle simultaneously a large number of links, operating with different forms of traffic and protocols from a number of terminals. It is characteristic of the military scenario that accesses come and go unpredictably, and requirements may vary rapidly. The system controller will need to respond to this, and in periods of high demand also take into account user priority. In practice a combination of manual (with computer support) and automatic demand assignment schemes may be in operation.

The Multiple Access problem is that of allocating and implementing the sharing of transponder capacity between a number of terminals, most of whom are operating on an SCPC basis*. Individual users may access a link by prior arrangement, or in conjunction with a polling or request channel. A group of users (a "Net") may employ their own protocol over an allocated channel (eg by time slot allocation, or random access contention operation), which may be outside the scope of the overall system controller who regards this simply as a single access (and who may not know which ground terminal is in use). Of course a link may be further multiplexed by the user, eg several telegraph channels @ 50 or 75 baud may be combined by TDM over a 2.4 kbit/s speech circuit.

* The term 'Channel' can have a number of loosely defined meanings (including a single communication circuit, or an entire transponder). It may help to define an Access as a separately identifiable signal from a ground station through a satellite. A Link is taken to mean an end-to-end signal path allocated between two ground stations, and may be "simplex" (ie one-way) or "duplex" (ie both directions of communication at once); - a duplex link involves 2 Accesses.

While traffic may be routed directly between medium-size terminals (eg 5 m diameter or more), the link budgets seldom permit direct small-terminal - to - small-terminal working. This would be achieved via an anchor station, with the penalty that a double hop is needed, and the use of the anchor node represents added vulnerability. The additional propagation delay may also be of significance.

One important military requirement is that of the "Broadcast": which is a one-way transmission from a large station to a large number of users, including small terminals. Such a service may be required to operate under the worst-case threat conditions, and may employ protection against jamming (as described later).

At UHF, transponders provide only a narrow-band capability, representing perhaps a single terminal access, and control is accordingly fairly straightforward. Some frequency division multiplex of low data rate signals from a single ground station may be possible.

At SHF (and EHF), a number of users share a wideband transponder, and apportion the downlink EIRP according to their uplink powers (together with any small signal suppression). This calls for careful planning, with appropriate frequency and power allocations to each user, together with good user power control. Computer programmes will assist in determination of uplink power as a function of the required C/N_0 of the link and of all other users sharing the transponder. Intermodulation products occurring within the transponder (notably the output power stages, eg TWTA) also need to be calculated and taken into account; these increase sharply as the TWT is driven into saturation, and the controller will determine any required back-off (and will perhaps command gain settings on the transponder). To achieve maximum downlink EIRP, military transponders generally tend to operate further into saturation than most civil systems.

TDMA (Time Division Multiple Access) may be used by high-data-rate strategic users, typically with PCM speech and/or data in a manner similar to civil systems. If such a system occupies an entire transponder, the entire transponder output power is used for each individual data symbol: this means that intermodulation problems are eliminated, and benefit may be made of the full saturated EIRP. In practice, a military transponder is likely also to include other forms of multiple access. TDMA has not generally been applied to small terminals to date, principally because of timing and control difficulties, and the complexity needed to achieve flexible response to changing access demands.

FDMA (Frequency Division Multiple Access) is commonly used in Milsatcoms. A frequency slot and power allocation is given to each link, and these are placed at appropriate intervals over the transponder BW, having regard to the precise position of intermodulation products. Usually it will be EIRP rather than available BW which limits the capacity of FDMA systems.

The advantages of FDMA are:

Users may be independent in terms of power, traffic and modulation scheme (eg analogue, PSK, FSK etc);

No overall time synchronisation is required, (ie only between Tx/Rx pairs);

Relative simplicity and cheapness.

The disadvantages of FDMA are:

Considerable intermodulation products due to mixing of frequencies in the transponder: these can interfere with other links, especially where strong and weak (ie high- and low- data rate) links are mixed. Intermodulation power also robs EIRP;

Signal suppression of weak carriers by strong carriers may matter, again especially with mix of link types;

The above problems call for very careful frequency selection, and may ultimately limit capacity. Large TWTA back-off helps intermods, but reduces EIRP.

FDMA may be used with pre-arranged assignments, including polling or request channels. Automatic assignment schemes (similar perhaps to the civilian SPADE system) are not yet generally employed in the military scenario.

Code Division Multiple Access (CDMA) is an alternative technique in wide military use. It is a form of Spread Spectrum (SS) communication (see 7.6), and is also known as Spread Spectrum Multiple Access (SSMA). Most CDMA systems use the Direct Sequence (DS) form of SS, but Frequency Hopping (FH) versions are also feasible. Somewhat different implementations of SS are widely employed for anti-jam (AJ) purposes, as discussed later: while CDMA does provide some AJ protection, it is not intended primarily for this purpose, but rather to alleviate some of the problems of FDMA.

In CDMA, each user modulates his transmit signal (narrowband) onto a wideband spreading function, which for DS CDMA would be a pseudo-random code at a "chip" rate of a few Mchip/s. Thus the transmission occupies a very wide bandwidth. The wanted receiver correlates its input with the same spreading function, suitably synchronised, to recover the signal. Each transmit-receive user pair employs a unique code, which is uncorrelated with codes in use by other transmit-receive pairs. In this way transmissions from unwanted users, and also any interference (including intermods), are partially rejected by the receiver despreading process, and may be modelled simply as Gaussian noise. Additionally, the peak levels of discrete intermodulation products generated in a transponder are considerably smaller than would be the case with narrow-band signals, permitting operation closer to saturation.

CDMA users may be assigned the same, overlapping, or separate carrier frequencies. As the number of users sharing a common bandwidth increases, the effective noise level rises and performance degrades smoothly and gracefully. Less stringent control and planning is called for than in FDMA or TDMA schemes. Although DS-CDMA is theoretically not as spectrally efficient as FDMA or TDMA, in practice the reduction in intermodulation levels permits a greater number of users to share a power-limited transponder than would be the case with FDMA. A penalty is that the terminal equipment is a good deal more complex, and expensive.

CDMA is currently being developed for civil small-terminal application. The principal merit of this application is that the relative immunity of CDMA to narrow-band interference (and vice-versa) permits operation where small terminal antenna beamwidths are so broad as to illuminate more than one satellite. However, the claims made for such systems are the subject of some debate^[5].

Fig 10 depicts the outline of a DS-CDMA transmitter and receiver; (the difficult problem of code synchronisation at the receiver is not addressed here). Fig 11 illustrates the concept of correlated and uncorrelated codes in a multiple access scheme.

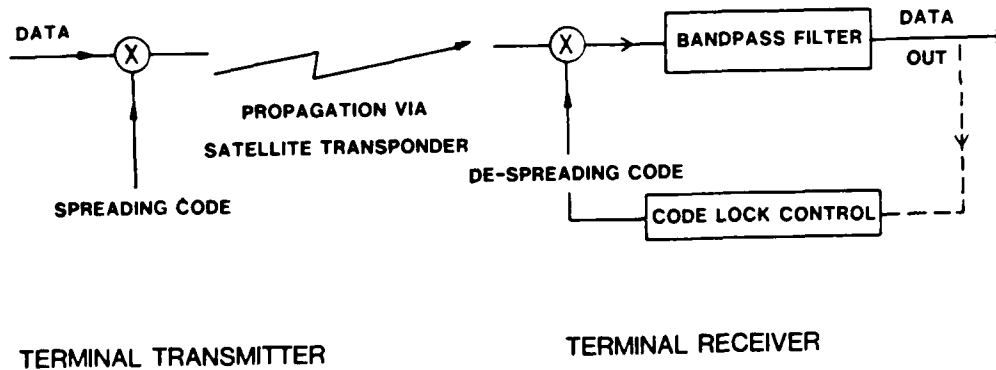
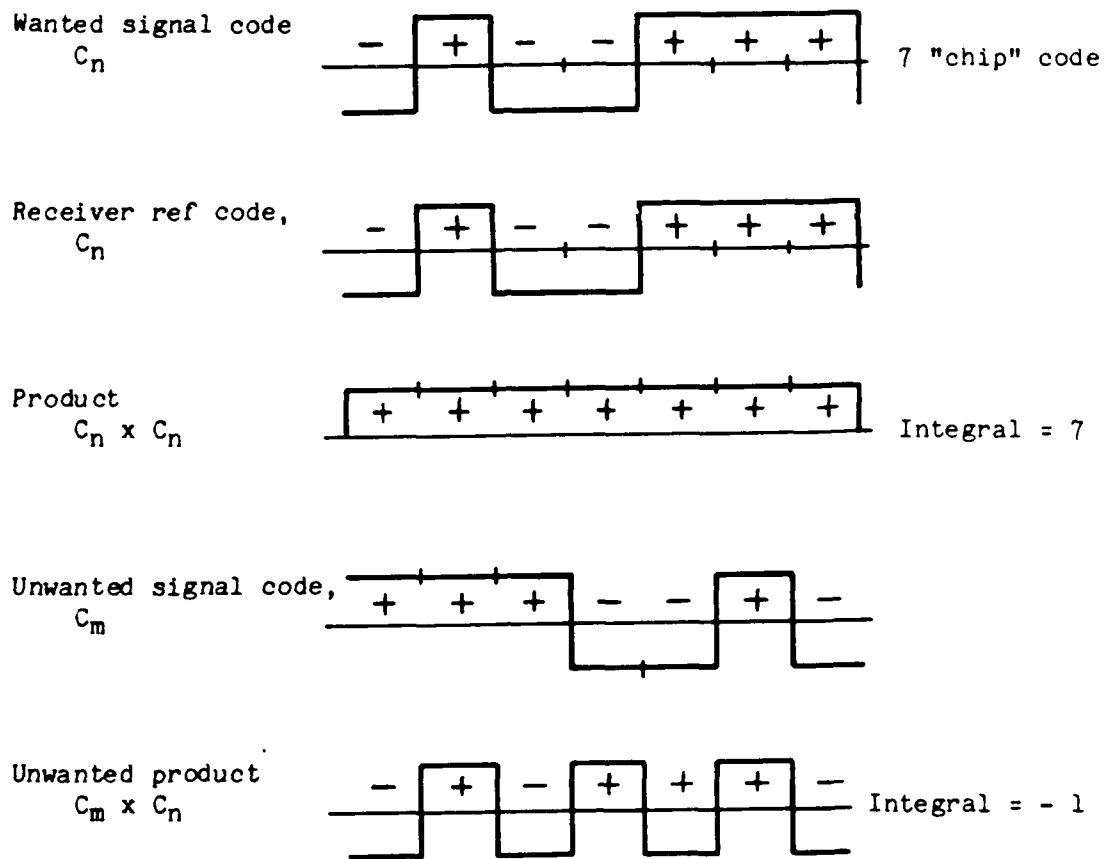

Fig 10 Direct-Sequence CDMA: Outline Implementation



C_n and C_m are "Quasi Orthogonal".

Code periods are typically hundreds or thousands of chips.

Mathematically:

$$\int C_n C_m \cdot dt \xrightarrow{n \neq m} 0$$

and

$$\int C_n C_n \cdot dt \xrightarrow{\text{large value}} \text{large value (ie correlation).}$$

Fig 11 Simple Illustration of Code Correlation in CDMA

7 THREATS & COUNTERMEASURES

7.1 General.

Milsatcoms are distinguished from civil systems by the requirement to provide survivability under threat. Protection against threats tends to be costly and restrictive, and may not be affordable for all users, thus a system is likely to provide different degrees of protection for different classes of user.

Physical threats are fairly obvious. Ground stations are clearly vulnerable, suggesting that some diversification of large anchor stations (for both traffic handling and TT&C) is desirable. Geostationary satellites themselves would require considerable resource to threaten directly, although one can speculate about high-energy lasers and particle beam or "directed energy" weapons.

7.2 Nuclear Threats.

Nuclear weapons pose special threats. Apart from the effects of any direct blast, these are: Radiation; EMP; and Atmospheric Ionisation.

Spaceborne electronics is subject to the natural radiation environment, which calls for appropriate shielding and choice of component technologies (eg TTL or CMOS-on-SOS rather than NMOS devices). Nuclear radiation threat levels may be considerably higher than this, and require further such protection ('Hardening'), against both transient upset and actual damage. Nuclear hardening is commonly employed in many military equipments, and tends to influence circuit design and equipment costs.

A nuclear detonation also produces an electromagnetic pulse (EMP). While the primary EMP may be insignificant at great distances, a significant secondary EMP effect can be induced in a spacecraft structure by the initial incident radiation pulse. Essentially this induces unwanted currents in a spacecraft, and careful engineering and shielding are required to protect electronic circuitry; such measures are similar to those required on all spacecraft against Electro-Static Discharge (ESD), which can follow the build up of charge on external insulating surfaces in the space environment.

Exo-atmospheric nuclear detonations can ionise the upper atmosphere, seriously affecting earth-space propagation over a very wide region. An initial period of attenuation is followed by a period of Nuclear Scintillation, where the signal fades rapidly. These effects may disrupt UHF communications for many hours, SHF for a few hours, and EHF momentarily. Some Milsatcom links may require to function during such periods. This requirement may be a strong driving force towards EHF for some scenarios, where suitable coding and interleaving may permit some survivable satellite communications during nuclear scintillation. Available open literature upon nuclear propagation is very sparse, although [6] and [16] do touch on some aspects.

7.3 Jamming.

Jamming is an attempt by an enemy to prevent communication by swamping a system with radiated power. It may be either Uplink or Downlink. Uplink jamming of a satellite transponder can be a serious threat, especially as most satellite receive antennas view hostile territory. It may be assumed that whatever high power can be radiated by a large ground station, a somewhat larger power may be radiated by a jammer of similar scale. The use of very high power gyrotron tubes at higher microwave frequencies by jammers may permit extremely high jammer EIRPs.

Fig 12 depicts uplink jamming. An uplink jammer will affect the signal directly, resulting in reduced SNR, and as the transponder is power-limiting, it can capture the downlink power. This results in an absolute reduction in the wanted downlink EIRP, plus additional Small Signal Suppression of up to 6 dB. The effect is that the transponder communications throughput is greatly reduced, and normal traffic may become virtually impossible.

Downlink jamming from an aircraft or other platform is also a threat, but one which may be physically removable (ie shot down). Both forms of jamming come within the term "ECM" - Electronic Counter Measures.

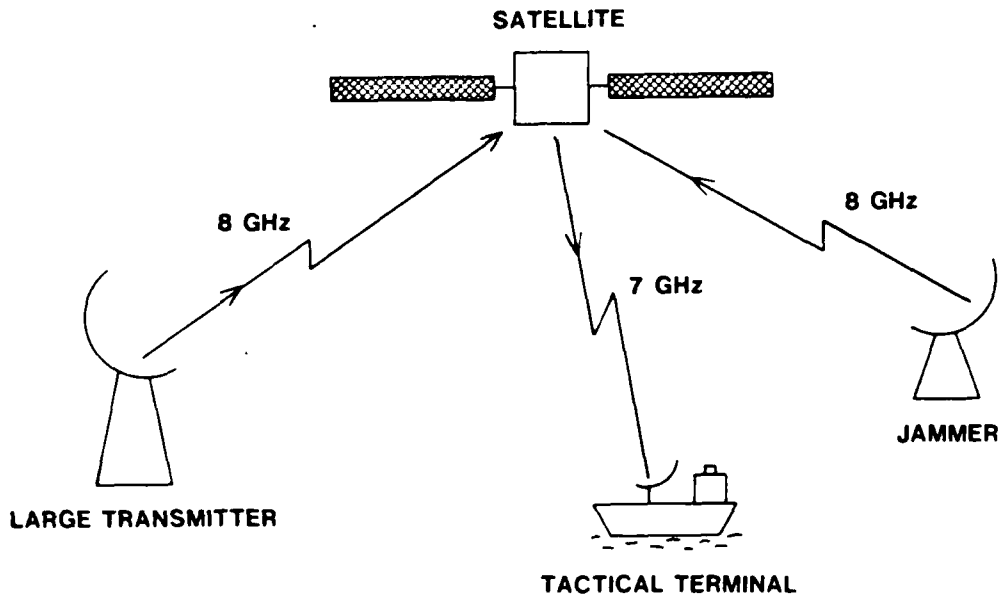

Fig 12 Uplink jamming concept

7.4 ECCM.

Electronic Counter Counter-Measures, or "ECCM", are the steps taken to alleviate ECM. In order to maximise communications capacity under jamming, it is necessary to remove as much jammer power as possible by techniques on board the satellite and/or at ground terminals. While Anti-Jamming (AJ) protection may be usefully applied at terminals, it may also be worthwhile to prevent an uplink jammer from capturing the satellite transponder power. There are two principal AJ techniques which may be used: Antenna Nulling, and Spread Spectrum. Each of these can achieve some degree of protection, at a penalty of added complexity and cost. The introduction of such techniques generally also results in reduced communications throughput, even when operating in a benign environment.

7.5 Antenna Nulling.

Antenna techniques on board the satellite may help alleviate the effects of uplink jamming. A reduced uplink coverage area may be used to enhance the wanted signal at the expense of a jammer provided the two are physically well separated. This is a simple and obvious measure, but requires a large aperture antenna and provides only limited discrimination; more importantly, it conflicts with the requirement for global coverage.

The concept may be extended however to the provision of an array of spot beam antennas, with selection of the appropriate coverage region. This would be integrated as a Multiple Beam Antenna (MBA), employing a number of feeds sharing a common dish reflector or else a waveguide lens structure. An MBA has the merit of providing flexible coverage with high gain, but in its simplest form gives only limited jammer rejection.

Improved jammer rejection of specific interference sources may be achieved by combining the signals from two or more elements of an MBA. One simple example realisation of nulling is shown in Fig 13, where the output from a spot-beam antenna, with a narrow beamwidth, is subtracted from that of an earth cover antenna with a wide beamwidth. On a purely amplitude basis, it can be seen how a narrow (and unique) null might be produced.

Fundamentally, this technique is similar to that of the Interferometer, as shown in Fig 14. Here a signal is received by two identical antennas, whose outputs are subtracted after imposition of a phase shift. The relative phase is a function of the path difference, which depends upon the angle of incidence; thus cancellation can be produced in a particular direction. This direction can be varied by telecommand control of the phase shifter.

The use of several antenna elements, together with both phase and amplitude control and combination, may permit considerable flexibility as a nulling antenna, and may allow simultaneous nulling of several interference sources. (In general N sources may be nulled by $N + 1$ antenna elements). It might also be possible to synthesise area nulls, for example over hostile territory without knowledge of specific jammer locations.

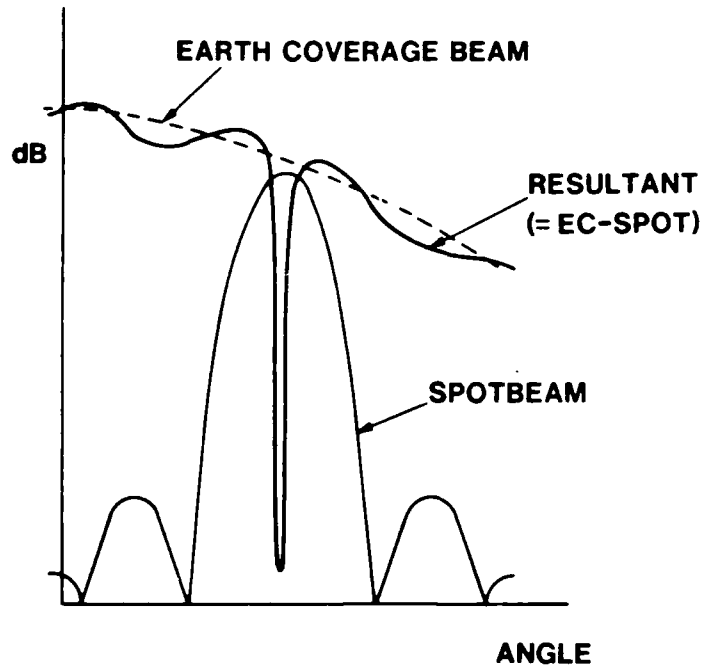
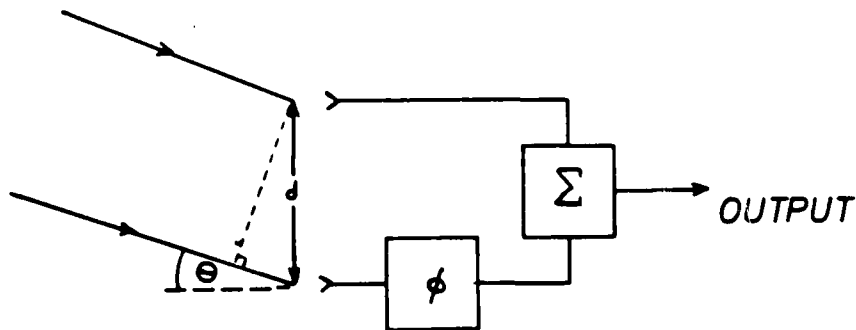

Fig 13 Illustration of antenna null realisation



CANCELLATION WHEN $2\pi \frac{d \sin \theta}{\lambda} + \phi = (2n-1)\pi$
 CONTROL OF ϕ STEERS NULL

Fig 14 Interferometer principle for nulling

Such sophisticated antennas would represent considerable complexity on a spacecraft. Constraints include the insertion loss which inevitably affects even wanted users, and there are demands for maintenance of performance over wide bandwidths and environmental temperature ranges. Efficient control is a major aspect, and this may be either by remote telecommand or locally through on-board adaptive algorithms: if the latter can be achieved, this helps alleviate some of the above difficulties.

Jammer nulling on a satellite is a far greater problem than for most land-based applications, as the narrow field of view may contain both wanted users and a number of interference sources with very small angular separation. There are clearly difficulties in distinguishing jammers from wanted signals, and future systems may be expected to rely upon distinctive signal coding, leading to integration of antenna sub-systems with spread spectrum processors.

7.6 Spread Spectrum Techniques

Spread Spectrum (SS) is an AJ technique which relies on the wanted user spreading his signal with a spreading function which cannot be replicated by an enemy. The receiver performs the inverse despreading operation, and the original signal is recovered through a narrow bandpass filter. This process spreads any uncorrelated interference such as jamming, the bulk of which is removed by the filter. The advantage given to the wanted signal over the interference is called the Processing Gain (PG), and is given broadly by the ratio of the spread bandwidth to the signal bandwidth. Fig 15 illustrates this concept.

There are two basic SS techniques: Direct Sequence (DS) (also called Pseudo-Noise or PN), and Frequency Hopping (FH).

Direct Sequence involves a linear modulation of the signal with a pseudo-random biphasic code, typically at several Mchip/s; thus the spectral width might be increased from (say) 10 kHz to 20 MHz (main lobe). At the despreading receiver, the identical operation is performed with the same spreading code, suitably synchronised in time and code phase. With these example parameters, a PG of 33 dB would be achieved - a typical figure. Technology tends to limit code chip rates to a few 10's of MHz, restricting the achievable PG. DS has been established in military communications for many years, and has the advantage that it may be used in a transparent fashion with virtually any form of constant envelope modulation.

Frequency Hopping requires the carrier frequency to jump in discrete hops over a wide bandwidth; the receiver recovers the signal by hopping its local oscillator in synchronism. Outline implementation is shown in Fig 16. A narrow band jammer will statistically affect only a small proportion of the hops, and error correction coding with interleaving at the receiver will deal with this. (The jammer may be forced to spread his power over a wide BW, but his effect against any individual hop is thus reduced). Again, a similar Processing Gain results. Hopping rates may range from 10 Hop/s to 20 kHop/s: the rate does not primarily affect the PG, which is determined by the frequency range (ie overall hopping BW). This is not essentially technology limited, but is likely to be determined by the satellite transponder BW.

Narrow Band Data Signal.

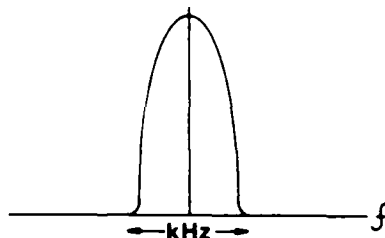

Multiplied by Spreading Code to give Wide Bandwidth Signal.



Transmitted.

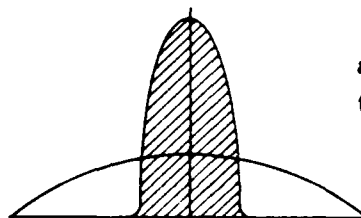

and subject to Jammer.

At Receiver Correlated with same Spreading Code. Data Signal Despread.

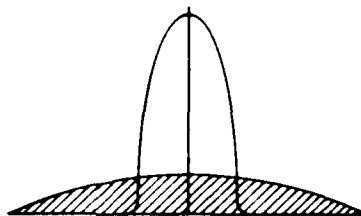

but Jammer now Spread.

Narrow Filter passes Data.

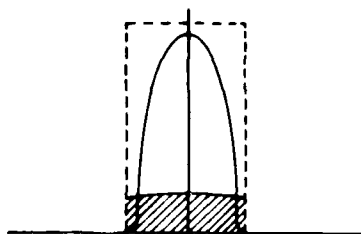

Advantage of Processing Gain.

Little Jammer Power remains.

Fig 15 Jamming protection through Spread Spectrum

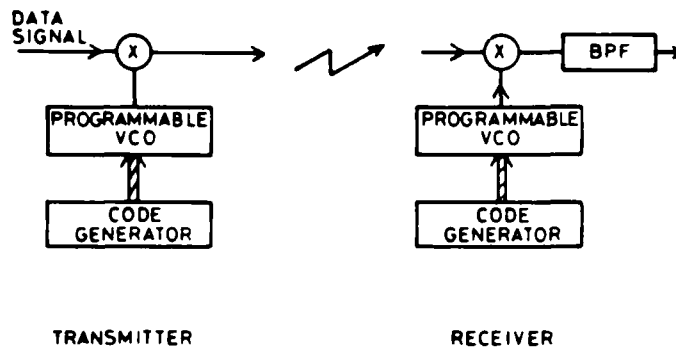

Fig 16 Frequency Hopping: outline implementation

The price paid for Spread Spectrum is the complexity and the difficulty of achieving synchronisation at the distant receiver. Eg a 10 Mchip/s DS system requires sync to a fraction of a chip, ie a few ns. FH systems are more robust, and may maintain sync for long periods with conventional crystal clocks set up on the 'time-of-day'. The acquisition and tracking circuitry itself has to function under conditions of jamming. Initial acquisition time may be a significant parameter of a receiver, and will itself be a function of the required maximum operating Jammer -to -Signal (J/S) ratio and of initial timing or code-state uncertainty.

In Milsatcom, SS may be used end-to-end with some advantage over a transparent wideband channel, but significant performance can only be maintained under heavy jamming if the despreading receiver itself is on board the satellite. The synchronisation problems here are evident, given uncertain propagation delays and Doppler shift, and the engineering of a self-contained spaceborne SS receiver represents a major technological challenge. The cost and complexity leads to such a protected facility being realistic for only a small community of users.

An essential feature of SS for AJ purposes is that the spreading code must not be capable of replication by an unauthorised user. This means that no amount of knowledge of past transmissions should allow prediction of future code states, and for this reason AJ systems tend to use not simple repetitive codes (eg m - sequences, or Gold codes) as do some CDMA systems, but non-linear spreading codes which do not repeat during the lifetime of the system.

With increasing threat levels, and requirements to work from small terminals, greater SS PGs are being called for. This is leading to the exploitation of EHF, where there is up to 2 GHz of allocated BW for wideband SS (see 8.2). This will be met by FH, while Hybrid SS schemes (where a DS signal is frequency hopped) are also feasible, and may have further benefits from an intercept viewpoint.

General and readable descriptions of SS techniques may be found in [7] & [8], while [9] provides full and detailed analyses for the system designer.

7.7 Low Probability of Exploitation (LPE).

Interception of traffic by an enemy represents a threat, especially for tactical terminals. It may permit location of the terminal, together with identification of its type and its activity (the traffic itself can be encrypted). While the downlink traffic from the terminal via the satellite may be readily interceptable, it yields limited information, and the uplink is the most vulnerable. This calls for 'Low Probability of Exploitation' (LPE) - a term which includes 'Low Probability of Intercept' (LPI). Interception is, in the limit, a statistical process, and may be viewed as the detection of weak signals (probably with some form of radiometer), in the presence of thermal noise.

Among important measures which a system designer may incorporate, are:

- (i) Spread Spectrum, which reduces the signal power spectral density and forces an interceptor to look over a greater noise bandwidth, with smaller probability of detection;
- (ii) Operating procedures which minimise the duration of transmissions;
- (iii) Terminal Antenna Design to reduce sidelobe radiation. As a rule of thumb, it may be taken that the radiation performance of a tactical terminal can lie within the range -10 dBi to 0 dBi in any direction away from the main beam. (The lower figure might apply to a land-based terminal well clear of surrounding clutter, while the higher figure might apply to a ship where the antenna is surrounded by much superstructure).

Bearing in mind the significant range advantage of an interceptor compared with a geostationary satellite, it can be appreciated that intercept can be a very significant threat. For further reading on Satcom LPE, see [10] & [7].

8 FUTURE TRENDS IN MILSATCOM

8.1 Enhanced on-board processing.

To extend protection against jamming to greater numbers of users, especially tactical terminals, greater use may be anticipated of SS on-board processing. This could for example handle FH uplinks from small terminals in multiple access fashion, (perhaps with an FDMA overlay), and could take advantage of the wide available BW at EHF to give very considerable PG. Other features such as demodulation to baseband, and data routing on board, may be envisaged akin to those proposed for civil systems using small terminals^[11]. Downlinks may be TDM for efficiency (which eases the intermodulation problem). Some scenarios may call for scanning downlink narrow spot beams, to provide a high peak EIRP on a time-shared basis.

Antenna technology will be critical to future developments. In addition to downlink antenna developments, sophisticated antenna arrays will be required for uplink reception. These may provide jammer rejection together with high gain and perhaps frequency re-use. On-board adaptive algorithms will discriminate against jamming or interference, and wanted signals may need to be distinguished by secure spread spectrum format. Developments may be anticipated in phased array antennas for spacecraft, where a reflecting dish or lens aperture is replaced by an array of elements each with suitably controlled amplitude and phase combining.

8.2 EHF.

Major exploitation of EHF may be envisaged in future Milsatcom systems. The uplink band is 43.5 - 45.5 GHz with downlinks @ 20.2 - 21.2 GHz, (and also 39.5 - 40.5 GHz). The 2 GHz of uplink BW permits considerable SS PG, (eg 2 GHz/10 kHz = 53 dB), giving realistic AJ protection with on-board despreading. The wide BW also allows high traffic capacity and relative freedom from regulatory constraints; orbital spacing of satellites could also be reduced, as even small tactical antennas will be capable of 1° beamwidths. EHF promises yet further advantages in ECCM, as the EIRP of a small terminal increases with frequency, while that of very large terminals (eg a jammer) tends to reach practical limits.

LPE may be considerably enhanced at EHF: apart from potential for wider BW SS (reducing intercept detectability), small terminal antennas may permit narrower beamwidths and improved side-lobe performance at the higher frequency band, and local rain attenuation may be more likely to disadvantage an interceptor than the user.

Other benefits of EHF lie in the small size and mass of hardware, especially satellite antennas. This may encourage the application of sophisticated on-board null-steering or adaptive antennas, which would otherwise be a problem at SHF. If operation in a post-nuclear scenario is required, the use of EHF may be almost mandatory to overcome Nuclear Scintillation propagation effects (see 7.2).

The disadvantages of EHF may be summarised as:

- (i) Heavy attenuation during rain. This is a real problem, and can to some extent be overcome by including large link margins (eg typically of the order of 12 dB for 99% link availability, depending upon elevation angle, compared with only a few dB @ SHF). However, one needs to examine the detailed statistics of rain outages. For military application, the duration of outages may be of more importance than the average availability (which is the commercial criterion), and it may be more realistic to try and accept short duration outages than to aim for significantly increased link margins.
- (ii) Antenna pointing. The narrow beamwidths achievable @ 44 GHz may demand more accurate pointing mechanisms for terminals, eg closed loop rather than open loop for a 1.7 m terminal. This could be a constraint for smaller man-portable terminals, where the operator is unlikely to be in a position to indulge in accurate pointing exercises.
- (iii) High cost & advanced technology: component and system costs are high, but may be expected to fall as the Milstar programme^[1] gets under way. The ultimate cost impact on satellites themselves may be advantageous however, due to size and mass savings.

A good analysis of EHF Milsatcoms may be found in [12].

8.3 Optical Satcoms.

There is interest in optical laser communication for Milsatcom. While this is particularly appropriate for inter-satellite links (where performance would seem to be comparable to an EHF system), there is also scope for space-to-ground communications subject to the obvious problems of cloud and rain. Such a system might operate at around 1.3 micron wavelength, most likely with Nd:YAG sources, and use pulse position modulation (PPM)[13]. The benefits of optical Satcoms are: very good LPE, mainly though very narrow beamwidths; small antenna (ie optics) apertures; wide bandwidth capability; potentially good jamming resistance. Current technology is largely based upon Direct Detection methods, but Coherent Detection systems, where the optical signal is heterodyned down to RF, offer considerable potential.

It has also been suggested that the use of blue-green light may permit communication to submarines below the sea surface^[14]. This might involve a one-way broadcast from a low orbiting satellite using a modulated scanning spot beam, an optical wavelength appropriate to transmission in sea water, and a very narrow receiver optical filter to reject background noise.

8.4 Inter-satellite links.

Inter-satellite links (or "Crosslinks"), may be used to extend the coverage area of a geostationary system, eliminating the need for intermediate anchor stations (and reducing delay), or as links between low orbiting and geostationary or supersynchronous satellites. With reduced dependence on vulnerable intermediate ground anchor stations, overall physical survivability may be enhanced. Communication could be either EHF @ 60 GHz, (which is in the oxygen absorption band, reducing probability of intercept on the ground), with CO₂ infrared lasers^[15], or optically. Calculations suggest that excessive powers are not required, and the main problems lie in the antenna/aperture acquisition and tracking.

9 BRIEF CONCLUSIONS

Milsatcoms are distinguished from civil systems by the requirement to handle a variety of different terminals over a wide area, and in the face of potential threats. Most traffic is carried at SHF, using shared wideband transparent transponders, with earth-cover satellite antennas. Smaller areas of coverage are also particularly important however, especially for use with small tactical terminals, which may, nevertheless, be able to operate at only very low data rates.

Survivability is a prime requirement, against which Jamming represents the principal threat. This may be alleviated by antenna nulling and by spread spectrum techniques. Such facilities should ideally be provided on board the satellite itself; they are costly and such protection may only be affordable for a limited community of users.

Future Milsatcom developments include the exploitation of the EHF band (44 GHz uplink), together with enhanced on-board processing.

REFERENCES

- [1] "Milstar to Close Dangerous C³I Gap" by J.B.Schultz. Defense Electronics, March 1983, pp 46 - 59.
- [2] "United Kingdom SKYNET 4 Defence Satellite Communications" by T.W.G.Dawson et al. Proceedings AIAA 9th Communications Satellite Systems Conference, San Diego, California, 7 - 11 March 1982.
- [3] "A Manpack Satellite Communications Earth Station" by C.H.Jones. The Radio and Electronic Engineer, Vol 51, No 6, June 1981, pp 259 - 271.
- [4] "Military Aeronautical Satellite Communications" by D.Cummings & C.G.Willey. IEE Proc Part F, Vol 133, No 4, July 1986, pp 411 - 419.
- [5] "When Not to Spread Spectrum - a Sequel" by A.J.Viterbi. IEEE Communications Magazine, Vol 23, No 4, April 1985, pp 12 - 17.
- [6] "Nuclear Effects on RF Propagation" by E.Smith. Defense Electronics, October 1984.
- [7] "Principles of Secure Communication Systems" by D.J.Torrieri. Artech House, 1985 (2nd edition).
- [8] "Spread Spectrum Systems" by R.C.Dixon. John Wiley & Sons, 1984 (2nd edition).
- [9] "Spread Spectrum Communications" by M.K.Simon, J.K.Omura, R.A.Scholtz & B.K.Levitt. (In 3 volumes). Computer Science Press 1985.
- [10] "Low Probability of Intercept" by A.B.Glenn. IEEE Communications Magazine, July 1983, pp 26 - 33.
- [11] "Baseband switches and transmultiplexers for use in an onboard processing mobile/business satellite system" by B.G.Evans et al. IEE Proc Part F, Vol 133, No 4, July 1986, pp 356 - 363.
- [12] "Fundamental Performance Characteristics That Influence EHF MILSATCOM Systems" by W.C.Cummings et al, IEEE Trans COM-27, No 10, Oct 1979, pp 1423 - 1435.
- [13] "Space Laser Communications" by R.W.Svorec & F.R.Gerardi. Photonics Spectra, April 1984, pp 78 - 81.
- [14] "The Role of Blue/Green Laser Systems in Strategic Submarine Communications" by T.F.Wiener & S.Karp. IEEE Trans COM-28, No 9, Sept 1980, pp 1602 - 1607.
- [15] "CO₂ Laser Communication Technology for Intersatellite Data Links" by L.Bonek & H.Lutz. ESA Journal, Vol 5, 1981, pp 83 - 98.
- [16] "Viterbi versus Sequential Decoding in a Scintillated Communication Channel" National Aerospace Electronics Conference, Vol 1, pp 564 - 571, Dayton, Ohio, 17 May 1983.

APPENDIX: LINK BUDGET ILLUSTRATIONS

By considering a few simplified link budgets, we illustrate some typical parameters and in particular the constraints of small terminal Satcom operation. We are concerned with an SHF geostationary satellite, having a transparent transponder of 10 MHz BW. Consider two terminal types: (a) Large Terminal: This might be an anchor station, and has a 10 m dish antenna with a 1 kW transmitter and a receive noise temperature of 200 K. (b) Small Terminal: This is based on the UK 'Manpack', and has a 45 cm dish with 2 W transmit power and 1000 K receive noise temperature. The actual terminal EIRPs are 88 dBW and 31 dBW respectively; these figures are taken from the specification (and account for antenna efficiency).

The path loss is as determined by frequency (which is taken here as 8 GHz for both up- and down- links, for simplicity), and by range. Range is taken as 37,000 km to a geostationary satellite. The satellite receive antenna gain is that of an earth cover antenna, which is about 17 dB irrespective of frequency. A similar antenna is taken for downlink transmit, with a TWTA of 20 W, giving an EIRP of 30 dBW.

Simplified specimen link budgets are shown in Table A1. Here we ignore link margins (for weather etc), and consider only a single access which takes the full saturated downlink EIRP of the transponder (in practice this may not be the case, and back off would additionally be applied). The resultant parameter of interest is the Carrier-to-Noise density, C/N_0 , expressed in dB-Hz. (This is often more useful than signal-to-noise ratio, SNR, being independent of any modulation scheme. It may help to visualise the C/N_0 as the SNR which would result if the signal were being detected within a 1 Hz BW).

Large Terminal power budget:

It is shown (i) that the large station uplink can produce a C/N_0 of 102 dB-Hz at the satellite front end. In the satellite transponder BW of 10 MHz (ie 70 dB-Hz), this yields 32 dB SNR, implying that the downlink power will be almost entirely wanted signal, with negligible noise contribution.

At the large-terminal receiver, the downlink C/N_0 is 92 dB-Hz (ii), implying 22 dB receive SNR over the full 10 MHz BW. This is adequate for most purposes, and indicates that noise is not a limitation in this system. It suggests that data rates up to at least 10 Mbit/s at negligible error rates should be achievable.

TABLE A1: SPECIMEN OUTLINE POWER BUDGETS

Geostationary Satellite @ 8 GHz. Weather margins not included here.

LARGE TERMINAL:

(i) Uplink

| | | | |
|---|---|--------|------------------|
| P = 1 kW | } | EIRP = | 88 dBW |
| 10m dish, G = 58 dB | | | |
| Path Loss | | = | 202 dB |
| Satellite Rx Antenna Gain | | = | 17 dB |
| Noise Temp T_N 1000 K (= 30 dBK) | } | kT = | -199 dBW/Hz |
| Boltzmann's const -229 dB/Hz/K | | | |
| <u>Resultant uplink C/N₀</u> | | = | <u>102 dB-Hz</u> |

(ii) Downlink

| | | | |
|---|---|--------|-----------------|
| P = 20 W | } | EIRP = | 30 dBW |
| EC antenna, G = 17 dB | | | |
| Path Loss | | = | 202 dB |
| Terminal Rx Antenna Gain | | = | 58 dB |
| Noise Temp T_N 200 K (= 23 dBK) | } | kT = | -206 dBW/Hz |
| Boltzmann's const -229 dB/Hz/K | | | |
| <u>Resultant downlink C/N₀</u> | | = | <u>92 dB-Hz</u> |

SMALL TERMINAL (eg Manpack):

(iii) Uplink

| | | | |
|---|---|--------|-----------------|
| P = 2 W | } | EIRP = | 31 dBW |
| 45 cm dish, G = 28 dB | | | |
| Path Loss | | = | 202 dB |
| Rx Antenna Gain | | = | 17 dB |
| Noise Temp T_N 1000 K (= 30 dBK) | } | kT = | -199 dBW/Hz |
| Boltzmann's const -229 dB/Hz/K | | | |
| <u>Resultant uplink C/N₀</u> | | = | <u>45 dB-Hz</u> |

(iv) Downlink

| | | | |
|---|---|--------|-----------------|
| P = 20 W | } | EIRP = | 30 dBW |
| EC antenna, G = 17 dB | | | |
| Path Loss | | = | 202 dB |
| Rx Antenna Gain | | = | 28 dB |
| Noise Temp T_N 1000 K (= 30 dBK) | } | kT = | -199 dBW/Hz |
| Boltzmann's const -229 dB/Hz/K | | | |
| <u>Resultant downlink C/N₀</u> | | = | <u>55 dB-Hz</u> |

Small Terminal (eg Manpack) Budget:

Consider the Manpack terminal uplink (iii), with an EIRP of only 31 dBW. The satellite received C/N_0 is 45 dB-Hz, which implies a transponder SNR (in 10 MHz) of - 25 dB! Thus with this single access, the satellite downlink power will be mostly thermal noise, and the wanted signal downlink EIRP is about $30 - 25 = 5$ dBW (neglecting here for the moment the small-signal suppression, which will reduce it a further 1 dB). This C/N_0 due to satellite front-end noise will appear at the downlink receiver together with the additional front-end noise of that receiver. The overall resultant C/N_0 is determined by the reciprocal of the sum of the reciprocals, although in practice one or other value may predominate. In the case of a large receive terminal, the downlink transmitted noise will still swamp local front-end noise, leaving an overall C/N_0 of 45 dB-Hz.

Now consider the downlink to the Manpack terminal (iv). If the full satellite EIRP were devoted to the signal, the receiver C/N_0 is 55 dB-Hz. This would apply with a large-station uplink, but if now our uplink is another Manpack, we have the reduction in signal EIRP of some 25 dB, which degrades the receiver C/N_0 from 55 to 30 dB-Hz. This poor figure predominates over the uplink C/N_0 of 45 dB-Hz to yield a resultant overall C/N_0 of approx 30 dB-Hz.

With these figures must be included practical link margins (see 6.2). At SHF a realistic figure is 6 dB (for ground - satellite - ground), although an optimist might choose 4 dB, and a pessimist 10 dB. Here we take a loss of 3 dB per path, and also add in Small Signal Suppression of 1 dB (where a weak uplink signal is below broadband noise, see 6.1). The C/N_0 figures are combined reciprocally such that

$$\frac{1}{(C/N_0)_{res}} = \frac{1}{(C/N_0)_{up}} + \frac{1}{(C/N_0)_{down}}$$

yielding the following results:

| | | | |
|----------------|---------------------|-------------|--------------|
| Large - Large: | Transponded C/N_0 | 99 | dB-Hz |
| | Downlink EIRP | 30 | dBW |
| | Receiver C/N_0 | 89 | dB-Hz |
| | Resultant C/N_0 | <u>88.6</u> | <u>dB-Hz</u> |
| Large - Small: | Transponded C/N_0 | 99 | dB-Hz |
| | Downlink EIRP | 30 | dBW |
| | Receiver C/N_0 | 52 | dB-Hz |
| | Resultant C/N_0 | <u>52</u> | <u>dB-Hz</u> |
| Small - Large: | Transponded C/N_0 | 42 | dB-Hz |
| | Downlink EIRP | 1 | dBW |
| | Receiver C/N_0 | 60 | dB-Hz |
| | Resultant C/N_0 | <u>42</u> | <u>dB-Hz</u> |
| Small - Small: | Transponded C/N_0 | 42 | dB-Hz |
| | Downlink EIRP | 1 | dBW |
| | Receiver C/N_0 | 23 | dB-Hz |
| | Resultant C/N_0 | <u>23</u> | <u>dB-Hz</u> |

(It is seen that the path loss margin has greatest effect on the already poor small-to-small terminal links, while the uplink losses may have little or no effect when the transponder is saturated).

These figures allow us to determine the capacity of the link. A practical modem may specify minimum operating C/N_0 , otherwise we can estimate the maximum achievable data rate from a knowledge of the E_b/N_0 requirements of the particular modulation concerned. If the energy per data bit is E_b , and the baud rate is R bit/s, then the carrier power C is given by $C = E_b R$; hence $C/N_0 = R E_b/N_0$. For most practical (binary) modulation schemes, a value of about 10 dB is required for E_b/N_0 , so the data rate is determined by subtracting 10 dB from the C/N_0 figures above. For example, if C/N_0 is 52 dB-Hz, R is $52 - 10 = 42$ dB-Hz, = 16 kHz.

On the basis of the above figures, for the single access described, we can arrive at the following results for maximum data rate:

| | | | |
|----------------|--------------------------|----------------|--------|
| Large - Large: | 10 MHz (ie transp BW) | Large - Small: | 16 kHz |
| Small - Large: | 1.6 kHz | Small - Small: | 20 Hz |

This shows that direct Manpack - Manpack communication is not feasible at a sensible data rate in this scenario, and it is necessary to route via a large anchor station, perhaps with baseband data regeneration. The above illustrations relate to only a single access; in practice a number of terminals would require simultaneous power sharing of the satellite channel, and this further reduces the available capacity (it is most unlikely that a single Manpack would be able to demand exclusive use of an entire SHF 10 MHz transponder!)

As the number of users increases, the satellite downlink EIRP has to be shared among them (FDMA or CDMA may be assumed, although similar principles apply to TDMA also). This will further reduce the received C/N_0 , and it can be seen that for downlinks to small terminals the already poor performance will further degrade. In order to increase the capacity, the downlink EIRP must be increased; the way to do this is through the use of spot beam antennas on the satellite. For example, if coverage were reduced from Earth Cover to give coverage of Western Europe, additional gain of the order of 15 dB might be achieved. The penalty is of course the coverage restriction thus imposed.

END

FEB.

1988

DTIC