



UTM
UNIVERSITI TEKNOLOGI MALAYSIA

Faculty of
Civil Engineering

**REINFORCED
CONCRETE
DESIGN TO EC2
FORMULAE AND DESIGN RULES**

FOR TEST AND FINAL EXAMINATION

4th. Edition January 2014



CONTENTS	Page
1.0 STRENGTH AND CHARACTERISTIC OF CONCRETE	1
- Table 3.1: Strength and deformation characteristics for concrete (Ref. Section 3: MS EN 1992-1-1: 2010)	
- Table F.1: Recommended limiting values for composition and properties of concrete (Ref. Section 3: EN 206-1: 2000)	
2.0 INDICATIVE DESIGN WORKING LIFE	3
(Ref. Section 2.3: MS EN 1990: 2010)	
- Table 2.1: Indicative design working life	
3.0 EFFECTIVE WIDTH OF FLANGES (ALL LIMIT STATES)	3
(Ref. Section 5.3.2: MS EN 1992-1-1: 2010)	
- Figure 5.2: Definition of l_0 for calculation of effective flanged width	
- Figure 5.3: Effective flanged width parameters	
4.0 DURABILITY, FIRE AND BOND REQUIREMENTS	4
(Ref. Section 4: MS EN 1992-1-1: 2010)	
- Exposure Class	
- Table 4.1: Exposure class related to environmental conditions in accordance with EN 206-1 (Ref. MS EN 1992-1-1: 2010)	
- Concrete Cover	
- Minimum Cover for Bond	
- Table 4.2: Minimum cover, $c_{min,b}$ requirements regard to bond (Ref. MS EN 1992-1-1: 2010)	
- Minimum Cover for Durability	
- Table 4.4N: Minimum cover, $c_{min,dur}$ requirements with regards to durability for reinforcement steel in accordance with EN 10080 (Ref. MS EN 1992-1-1: 2010)	
- Table 4.5N: Minimum cover, $c_{min,dur}$ requirements with regards to durability for prestressing steel (Ref. MS EN 1992-1-1: 2010)	
- Table 4.3N: Recommended structural classification (Ref. MS EN 1992-1-1: 2010)	
- Minimum Cover for Fire (Ref. MS EN 1992-1-2: 2004)	
- Table 5.5: Minimum dimensions and axis distances for simply supported beams made with reinforced and prestressed concrete	
- Table 5.6: Minimum dimensions and axis distances for continuous beams made with reinforced and prestressed concrete.	
- Table 5.8: Minimum dimensions and axis distances for simply supported one-way and two-way solid slabs	
- Table 5.2a: Minimum column dimensions and axis distances for columns with rectangular or circular section	
5.0 EFFECTIVE SPAN OF BEAMS AND SLABS IN BUILDING	9
(Ref. Section 5.3.2.2: MS EN 1992-1-1: 2010)	
- Figure 5.4: Effective span, l_{eff} for different support conditions	
6.0 DESIGN FOR FLEXURE	10
(Ref. Section 6.1: MS EN 1992-1-1: 2010)	
- Design Procedure for Rectangular Section	
- Design Procedure for Flanged Section	
- Minimum and Maximum Area of Reinforcement (Ref. Section 9.2: MS EN 1992-1-1: 2010)	
7.0 DESIGN FOR SHEAR	12
(Ref. Section 6.2: MS EN 1992-1-1: 2010)	
- Members Requiring Design Shear Reinforcement	
- Procedure for Calculating Transverse Shear Reinforcement in Flanged Section	
- Minimum Area of Reinforcement in the Flange	
- Sections Not Requiring Design Shear Reinforcement	

8.0	DEFLECTION <i>(Ref. Section 7.4: MS EN 1992-1-1: 2010)</i> - Table 7.4N: Basic span/effective depth ratio (Typical values for rectangular section for steel grade $f_{yk} = 500$ N/mm ² and concrete class C30/35)	14
9.0	CRACKING <i>(Ref. Section 7.3: MS EN 1992-1-1: 2010)</i> - Table 7.1N: Recommended values of w_{max} (mm) - Minimum Reinforcement Area - Control of Cracking without Direct Calculation - Table 7.2N: Maximum bar spacing for crack control - Table 7.3N: Maximum bar diameters for crack control	15
10.0	MOMENT AND SHEAR COEFFICIENT FOR CONTINUOUS BEAM - Table 3.5: Moments and shear coefficients of continuous beam <i>(Ref. BS 8110: Part 1: 1997)</i>	17
11.0	SIMPLIFIED CURTAILMENT RULES FOR BEAM - Figure 1: Simplified detailing rules for beams	17
12.0	MOMENT AND SHEAR COEFFICIENT FOR SOLID SLAB - Continuous One-way Slab - Table 3.12: Ultimate moment and shear coefficients in continuous one way slab <i>(Ref. BS 8110: Part 1: 1997)</i> - Two-way Simply Supported Slab - Table 3.13: Bending moment coefficient for simply supported two-way slab <i>(Ref. BS 8110: Part 1: 1997)</i> - Two-way Restrained Slab - Table 3.14: Bending moment coefficients for two-way restrained slab <i>(Ref. BS 8110: Part 1: 1997)</i> - Shear Force for Two-way Restrained Slab and Actions on Supporting Beams - Table 3.15: Shear force coefficients for restrained two-way slab <i>(Ref. BS 8110: Part 1: 1997)</i>	18
13.0	CRACKING RULES FOR SLAB <i>(Ref. Section 9.3: MS EN 1992-1-1: 2010)</i>	21
14.0	SIMPLIFIED CURTAILMENT RULES FOR SLAB <i>(Ref. "How to design concrete structures using Eurocode 2", The Concrete Centre, 2010)</i> - Figure 2: Simplified detailing rules for slabs	21
15.0	PRESTRESSED MEMBERS AND STRUCTURES - Limitation of Concrete Stress (Ref. Section 5.10.2.2: MS EN 1992-1-1: 2010) - Table 1: Limitation of Concrete Stress	22
16.0	DESIGN OF COLUMNS - Slenderness ratio (Ref. Section 5.8.3.2 MS EN 1992:2010) - Slenderness Limit (Ref. Section 5.8.3.1 MS EN 1992:2010) - Longitudinal Reinforcement (Ref. Section 9.5.2 MS EN 1992:2010) - Transverse Reinforcement (Ref. Section 9.5.3 MS EN 1992:2010) - Design Moments (Ref. Section 5.8.7 MS EN 1992:2010) - Biaxial Bending (Ref. Section 5.8.9 MS EN 1992:2010) - Column design chart	23
17.0	FRAME ANALYSIS - Method of Analysis (Ref. Section 5.1 MS EN 1992:2010) - Load Cases and Combination (Ref. Section 5.1.3 MS EN 1992:2010) - Analysis of Frame for Lateral Loads - Calculation of Wind Load	29

18.0	DESIGN OF FOUNDATIONS	31
	- Design of pad footing	
	- Cracking and detailing requirements	
	- Design of Pile Foundation	
19.0	DESIGN OF RETAINING WALLS	36
	- Table 1: Partial safety factor at the ultimate limit state	
	- Stability analysis	
	- Element design and detailing	
20.0	BAR AREAS	38
	- Table A: Sectional areas of groups of bars (mm ²)	
	- Standard fabric	

1.0 STRENGTH AND CHARACTERISTIC OF CONCRETE

Table 3.1: Strength and deformation characteristics for concrete (*Ref. Section 3: MS EN 1992-1-1: 2010*)

Strength classes for concrete														Analytical relation / Explanation
	12	16	20	25	30	35	40	45	50	55	60	70	80	
f_{ck} (MPa)	12	16	20	25	30	35	40	45	50	55	60	70	80	90
$f_{ck,cube}$ (MPa)	15	20	25	30	37	45	50	55	60	67	75	85	95	105
f_{cm} (MPa)	20	24	28	33	38	43	48	53	58	63	68	78	88	98
f_{cm} (MPa)	1.6	1.9	2.2	2.6	2.9	3.2	3.5	3.8	4.1	4.2	4.4	4.6	4.8	5.0
$f_{ctk,0.05}$ (MPa)	1.1	1.3	1.5	1.8	2.0	2.2	2.5	2.7	2.9	3.0	3.1	3.2	3.4	3.5
$f_{ctk,0.95}$ (MPa)	2.0	2.5	2.9	3.3	3.8	4.2	4.6	4.9	5.3	5.5	5.7	6.0	6.3	6.6
E_{cm} (GPa)	27	29	30	31	33	34	35	36	37	38	39	41	42	44
ϵ_{c1} (‰)	1.8	1.9	2.0	2.1	2.2	2.25	2.3	2.4	2.45	2.5	2.6	2.7	2.8	2.8
ϵ_{cu1} (‰)	3.5													
ϵ_{cu2} (‰)	2.0													
ϵ_{cu2} (‰)	3.5													
n	2.0													
ϵ_{cu3} (‰)	1.75													
ϵ_{cu3} (‰)	3.5													

Table F.1: Recommended limiting values for composition and properties of concrete
(Ref. Section 3: EN 206-1: 2000)

Page 62
EN 206-1:2000

Table F.1 — Recommended limiting values for composition and properties of concrete

	Exposure classes																
	No risk of corrosion or attack	Carbonation-induced corrosion				Chloride-induced corrosion			Freeze/thaw attack					Aggressive chemical environments			
						Chloride other than from sea water											
	XC 1	XC 2	XC 3	XC 4	XS 1	XS 2	XS 3	XD 1	XD 2	XD 3	XF 1	XF 2	XF 3	XF 4	XA 1	XA 2	XA 3
Maximum w/c	0,65	0,60	0,55	0,50	0,50	0,45	0,45	0,55	0,55	0,45	0,55	0,55	0,50	0,45	0,55	0,50	0,45
Minimum strength class	C20/25	C25/30	C30/37	C30/37	C30/37	C35/45	C35/45	C30/37	C30/37	C35/45	C30/37	C25/30	C30/37	C30/37	C30/37	C30/37	C35/45
Minimum cement content (kg/m ³)	260	280	280	300	300	320	340	300	300	320	300	300	320	340	300	320	360
Minimum air content (%)	—	—	—	—	—	—	—	—	—	—	—	4,0 ^a	4,0 ^a	4,0 ^a	—	—	—
Other requirements	Aggregate in accordance with EN 12620 with sufficient freeze/thaw resistance																
^a Where the concrete is not air entrained, the performance of concrete should be tested according to an appropriate test method in comparison with a concrete for which freeze/thaw resistance for the relevant exposure class is proven.																	
^b When SO ₄ ²⁻ leads to exposure Classes XA2 and XA3, it is essential to use sulfate-resisting cement. Where cement is classified with respect to sulfate resistance, moderate or high sulfate-resisting cement should be used in exposure Class XA2 (and in exposure Class XA1 when applicable) and high sulfate-resisting cement should be used in exposure Class XA3.																	

2.0 INDICATIVE DESIGN WORKING LIFE

(Ref. Section 2.3: MS EN 1990: 2010)

Table 2.1: Indicative design working life

Design working life category	Indicative design working life (years)	Examples
1	10	Temporary structures ⁽¹⁾
2	10 to 25	Replaceable structural parts, e.g. gantry girders, bearings
3	15 to 30	Agricultural and similar structures
4	50	Building structures and other common structures
5	100	Monumental building structures, bridges, and other civil engineering structures

(1) Structures or parts of structure that can be dismantled with a view to being re-used should not be considered as temporary

3.0 EFFECTIVE WIDTH OF FLANGES (ALL LIMIT STATES)

(Ref. Section 5.3.2: MS EN 1992-1-1: 2010)

The effective flanged width, b_{eff} for a T-beam or L-beam may be derived as

$$b_{eff} = \sum b_{eff,i} + b_w \leq b$$

where

$$b_{eff,i} = 0.2b_i + 0.1l_o \leq 0.2l_o$$

and

$$b_{eff,i} \leq b_i$$

l_o is the distance between point of zero moment can be obtained from Figure 5.2. Other notations are given in Figure 5.3.

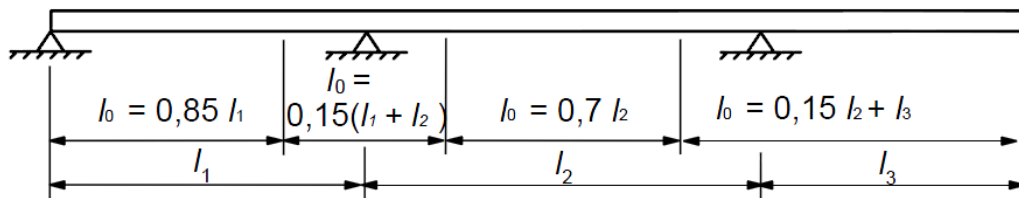

Figure 5.2: Definition of l_o for calculation of effective flanged width

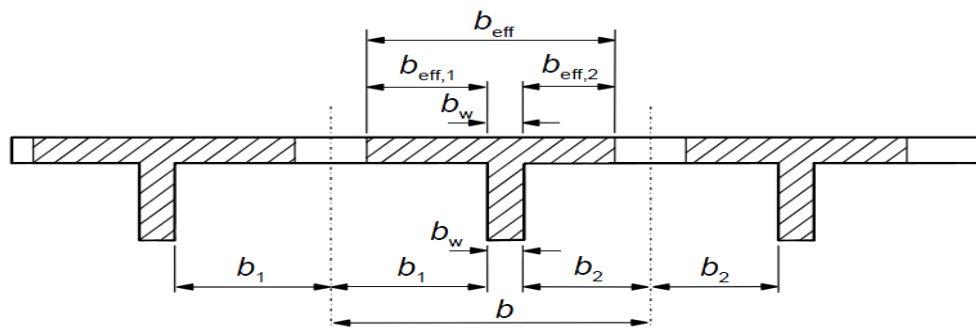

Figure 5.3: Effective flanged width parameters

4.0 DURABILITY, FIRE AND BOND REQUIREMENTS

(Ref. Section 4: MS EN 1992-1-1: 2010)

Exposure Class

Table 4.1: Exposure class related to environmental conditions in accordance with EN 206-1
(Ref. MS EN 1992-1-1: 2010)

Class designation	Description of the environment	Informative examples where exposure classes may occur
1 No risk of corrosion attack		
XC0	For concrete without reinforcement or embedded metal: all exposure except where there is freeze/thaw, abrasion or chemical attack For concrete with reinforcement or embedded metal: very dry	Concrete inside buildings with very low air humidity
2 Corrosion induced by carbonation		
XC1	Dry or permanently wet	Concrete inside building with low air humidity Concrete permanently submerged in water
XC2	Wet, rarely dry	Concrete surfaces subject to long-term water contact Many foundations
XC3	Moderate humidity	Concrete inside buildings with moderate or high air humidity External concrete sheltered from rain
XC4	Cyclic wet and dry	Concrete surfaces subject to water contact, not within the exposure class XC2
3 Corrosion induced by chlorides		
XD1	Moderate humidity	Concrete surfaces exposed to airborne chlorides
XD2	Wet, rarely dry	Swimming pools Concrete components exposed to industrial waters containing chlorides
XD3	Cyclic wet and dry	Parts of bridges exposed to spray containing chlorides Pavements Car park slabs
4 Corrosion induced by chlorides from sea water		
XS1	Exposed to airborne salt but not in direct contact to sea water	Structures near to or on the coast
XS2	Permanently submerged	Parts of marine structures
XS3	Tidal, splash and spray zones	Parts of marine structures
5 Freeze/Thaw attack		
XF1	Moderate water saturation, without de-icing agent	Vertical concrete surfaces exposed to rain and freezing
XF2	Moderate water saturation, with de-icing agent	Vertical concrete surfaces of road structures exposed to freezing and air-borne de-icing agents
XF3	High water saturation, without de-icing agents	Horizontal concrete surfaces exposed to rain and freezing
XF4	High water saturation, with de-icing agents or sea water	Road and bridge decks exposed to de-icing agents Concrete surfaces exposed to direct spray containing de-icing agents and freezing Splash zone of marine structures exposed to freezing
6 Chemical attack		
XA1	Slightly aggressive chemical environment according to EN 206-1, Table 2	Natural soils and ground water
XA2	Moderately aggressive chemical environment according to EN 206-1, Table 2	Natural soils and ground water
XA3	Highly aggressive chemical environment according to EN 206-1, Table 2	Natural soils and ground water

Concrete Cover

The nominal cover is given as:

$$c_{\text{nom}} = c_{\text{min}} + \Delta c_{\text{dev}}$$

where Δc_{dev} is an allowance which should be made in the design for deviation from the minimum cover. It should be taken as 10 mm. It is permitted to reduce to 5 mm if the fabrication subjected to a quality assurance system

c_{min} is the minimum cover sets to satisfy the requirements for safe transmission of bond forces, durability and fire resistance

Minimum Cover for Bond

Table 4.2: Minimum cover, $c_{\text{min, b}}$ requirements regard to bond (Ref. MS EN 1992-1-1: 2010)

Bond Requirement	
Arrangement of bars	Minimum cover, $c_{\text{min, b}}^*$
Separated	Diameter of bar
Bundled	Equivalent diameter $\phi_n = \phi \sqrt{n_b} \leq 55 \text{ mm}$ where n_b is the number of bars in the bundle, which is limited to $n_b \leq 4$ for vertical bars in compression $n_b \leq 3$ for all other cases
* If the nominal maximum aggregate size is greater than 32 mm, $c_{\text{min, b}}$ should be increased by 5 mm	

Minimum Cover for Durability

Table 4.4N: Minimum cover, $c_{\text{min, dur}}$ requirements with regards to durability for reinforcement steel in accordance with EN 10080 (Ref. MS EN 1992-1-1: 2010)

Structural Class	Exposure Class according to Table 4.1 EC 2						
	X0	XC1	XC2/XC3	XC4	XD1/XS1	XD2/XS2	XD3/XS3
S1	10	10	10	15	20	25	30
S2	10	10	15	20	25	30	35
S3	10	10	20	25	30	35	40
S4	10	15	25	30	35	40	45
S5	15	20	30	35	40	45	50
S6	20	25	35	40	45	50	55

Table 4.5N: Minimum cover, $c_{\text{min, dur}}$ requirements with regards to durability for prestressing steel (Ref. MS EN 1992-1-1: 2010)

Structural Class	Exposure Class according to Table 4.1 EC 2						
	X0	XC1	XC2/XC3	XC4	XD1/XS1	XD2/XS2	XD3/XS3
S1	10	15	20	25	30	35	40
S2	10	15	25	30	35	40	45
S3	10	20	30	35	40	45	50
S4	10	25	35	40	45	50	55
S5	15	30	40	45	50	55	60
S6	20	35	45	50	55	60	65

The minimum cover values for reinforcement and prestressing tendons in normal weight concrete taking account of the exposure classes and the structural classes is given by $c_{min,dur}$.

Note: Structural classification and values of $c_{min,dur}$ for use in a Country may be found in its National Annex. The recommended Structural Class (design working life of 50 years) is S4 for the indicative concrete strengths given in Annex E and the recommended modifications to the structural class is given in Table 4.3N. The recommended minimum Structural Class is S1.

Table 4.3N: Recommended structural classification (Ref. MS EN 1992-1-1: 2010)

Criterion	Structural Class						
	Exposure Class according to Table 4.1						
	X0	XC1	XC2/XC3	XC4	XD1	XD2/XS1	XD3/XS2/XS3
Design Working Life of 100 years	Increase class by 2	Increase class by 2	Increase class by 2	Increase class by 2	Increase class by 2	Increase class by 2	Increase class by 2
Strength Class ^{(1) (2)}	≥ C30/37 Reduce class by 1	≥ C30/37 Reduce class by 1	≥ C35/45 Reduce class by 1	≥ C40/50 Reduce class by 1	≥ C40/50 Reduce class by 1	≥ C40/50 Reduce class by 1	≥ C45/55 Reduce class by 1
Member with Slab Geometry (position of reinforcement not affected by construction process)	Reduce class by 1	Reduce class by 1	Reduce class by 1	Reduce class by 1	Reduce class by 1	Reduce class by 1	Reduce class by 1
Special Quality Control of the Concrete Production Ensured	Reduce class by 1	Reduce class by 1	Reduce class by 1	Reduce class by 1	Reduce class by 1	Reduce class by 1	Reduce class by 1

Notes to Table 4.3N:

1. The strength class and w/c ratio are considered to be related values. A special composition (type of cement, w/c value, fine fillers) with the intent to produce low permeability may be considered.
2. The limit may be reduced by one strength class if air entrainment of more than 4% is applied.

Minimum Cover for Fire (Ref. MS EN 1992-1-2: 2004)

Rather than giving a minimum cover, the tubular method based on nominal axis distance is used. This is the distance from the centre of the main reinforcement bar to the top or bottom surface of the member. The designer should ensure that:

$$a \geq c_{nom} + \phi_{link} + \frac{\phi_{bar}}{2}$$

where the nominal axis distance, a is illustrated in Figure 5.2. The permissible combinations of member dimension and axis distance are given in Table 5.5 and 5.6 for beams and Table 5.8 for slabs.

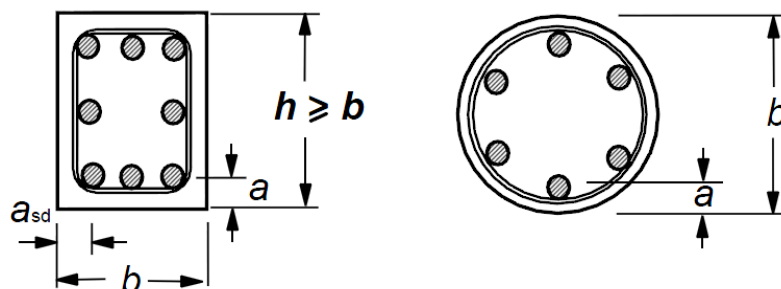

Figure 5.2: Section through structural members, showing nominal axis distance a

Table 5.5: Minimum dimensions and axis distances for simply supported beams made with reinforced and prestressed concrete (Ref. Table 5.5 EN 1992-1-2)

Standard Fire Resistance		Minimum Dimensions (mm)						
		Possible combinations of a and b_{\min} where a is the average axis distance and b_{\min} in the width of beam (mm)				Web thickness, b_w (mm)		
						Class WA	Class WB	Class WC
1	2	3	4	5	6	7	8	
R 30	$b_{\min} =$ $a =$	80 25	120 20	160 15*	200 15*	80	80	80
R 60	$b_{\min} =$ $a =$	120 40	160 35	200 30	300 25	100	80	100
R 90	$b_{\min} =$ $a =$	150 55	200 45	300 40	400 35	110	100	100
R 120	$b_{\min} =$ $a =$	200 65	240 60	300 55	500 50	130	120	120
R 180	$b_{\min} =$ $a =$	240 80	300 70	400 65	600 60	150	150	140
R 240	$b_{\min} =$ $a =$	280 90	350 80	500 75	700 70	170	170	160
$a_{sd} = a + 10$ mm (see note below)								
For prestressed beams the increase of axis distance according to 5.2(5) should be noted.								
a_{sd} is the distance to the side of beam for the corner bars (or tendon or wire) of beams with only one layer of reinforcement. For values of b_{\min} greater than that given in Column 4 no increase of a_{sd} is required								
* Normally the cover required by EN 1992-1-1 will control								

Table 5.6: Minimum dimensions and axis distances for continuous beams made with reinforced and prestressed concrete (Ref. Table 5.6 EN 1992-1-2)

Standard Fire Resistance		Minimum Dimensions (mm)						
		Possible combinations of a and b_{\min} where a is the average axis distance and b_{\min} in the width of beam (mm)				Web thickness, b_w (mm)		
						Class WA	Class WB	Class WC
1	2	3	4	5	6	7	8	
R 30	$b_{\min} =$ $a =$	80 15*	160 12*			80	80	80
R 60	$b_{\min} =$ $a =$	120 25	200 12*			100	80	100
R 90	$b_{\min} =$ $a =$	150 35	250 25			110	100	100
R 120	$b_{\min} =$ $a =$	200 45	300 35	450 35	500 30	130	120	120
R 180	$b_{\min} =$ $a =$	240 60	400 50	550 50	600 40	150	150	140
R 240	$b_{\min} =$ $a =$	280 75	500 60	650 60	700 50	170	170	160
$a_{sd} = a + 10$ mm (see note below)								
For prestressed beams the increase of axis distance according to 5.2(5) should be noted.								
a_{sd} is the distance to the side of beam for the corner bars (or tendon or wire) of beams with only one layer of reinforcement. For values of b_{\min} greater than that given in Column 3 no increase of a_{sd} is required								
* Normally the cover required by EN 1992-1-1 will control								

Table 5.8: Minimum dimensions and axis distances for simply supported one-way and two-way solid slabs
(Ref. Table 5.8 EN 1992-1-2)

Standard Fire Resistance	Minimum Dimensions (mm)			
	Slab thickness, h_s (mm)	One-way spanning	Two-way spanning	
			$\frac{l_y}{l_x} \leq 1.5$	$1.5 < \frac{l_y}{l_x} \leq 2.0$
1	2	3	4	5
REI 30	60	10*	10*	10*
REI 60	80	20	10*	15*
REI 90	100	30	15*	20
REI 120	120	40	20	25
REI 180	150	55	30	40
REI 240	175	65	40	50

l_x and l_y are shorter and longer span of the two-way slab

- For prestressed slabs the increase of axis distance according to 5.2(5) should be noted
- The axis distance a in Column 4 and 5 for two-way slabs relate to slabs supported at all four edges. Otherwise, they should be treated as one-way spanning slab.

* Normally the cover required by EN 1992-1-1 will control

Table 5.5: Minimum dimension and axis distance of columns with rectangular or circular section
(Ref. Table 5.2a EN 1992-1-2)

Standard fire resistance	Minimum dimensions (mm)			
	Column width b_{min} /axis distance a of the main bars			
	Column exposed on more than one side			Exposed on one side
	$\mu_{fi} = 0.2$	$\mu_{fi} = 0.5$	$\mu_{fi} = 0.7$	$\mu_{fi} = 0.7$
R60	200/25	200/36 300/31	250/46 350/40	155/25
R90	200/31 300/25	300/45 400/38	350/53 450/40	155/25
R120	250/40 350/35	350/45 450/40	350/57 450/51	175/35

μ_{fi} = design axial load in the fire situation / design resistance at normal condition

5.0 EFFECTIVE SPAN OF BEAMS AND SLABS IN BUILDING (Ref. Section 5.3.2.2: MS EN 1992-1-1: 2010)

The effective span of a member, l_{eff} should be calculated as follows:

$$l_{\text{eff}} = l_n + a_1 + a_2$$

where l_n is the clear distance between the faces of the support
 a_1 and a_2 is the $\min \{0,5h; 0,5t\}$, where h is the overall depth of the member and t is the width of the supporting element

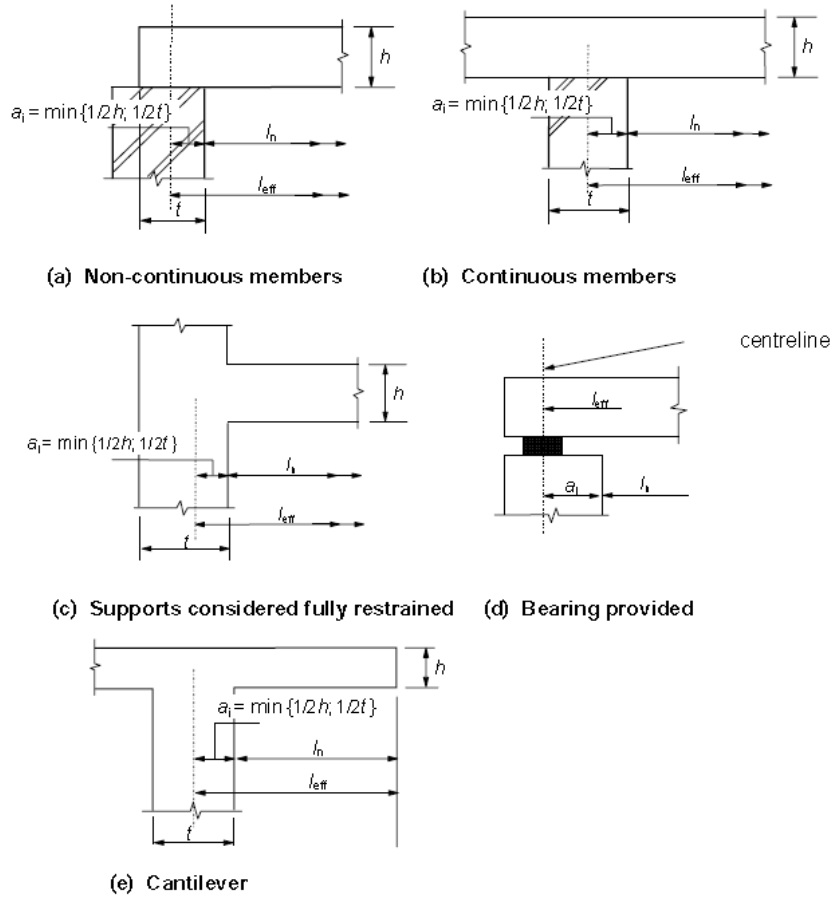

Figure 5.4: Effective span, l_{eff} for different support conditions

6.0 DESIGN FOR FLEXURE (Ref. Section 6.1: MS EN 1992-1-1: 2010)

Design Procedure for Rectangular Section

Supposed the bending moment is M , beam section is $b \times b$, concrete strength is f_{ck} and steel strength is f_{yk} , to determine the area of reinforcement, proceed as follows:

The steps are only for valid for $f_{ck} \leq 50$ MPa. For concrete compressive strength, $50 \text{ MPa} < f_{ck} \leq 90 \text{ MPa}$, modification of the stress block should be in accordance to Section. 3.1.7: MS EN 1992-1-1: 2010.

1. Calculate $K = \frac{M}{f_{ck}bd^2}$
2. Calculate $K_{bal} = 0.363(\delta - 0.44) - 0.116(\delta - 0.44)^2$

$$\text{where } \delta = \frac{\text{Moment at section after redistribution}}{\text{Moment at section before redistribution}} \leq 1.0$$

$$\text{and for } \delta = 1.0 \rightarrow K_{bal} = 0.167$$

3. If $K \leq K_{bal}$, compression reinforcement is not required, and

$$z = d \left[0.5 + \sqrt{\left(0.25 - \frac{K}{1.134} \right)} \right]$$

Calculate tension reinforcement:

$$A_s = \frac{M}{0.87f_{yk}z}$$

4. If $K > K_{bal}$, compression reinforcement is required, and

$$z = d \left[0.5 + \sqrt{\left(0.25 - \frac{K_{bal}}{1.134} \right)} \right]$$

$$x = \frac{(d - z)}{0.4}$$

Calculate compression reinforcement:

Check d'/x :

$$A'_s = \frac{(K - K_{bal})f_{ck}bd^2}{0.87f_{yk}(d - d')} \quad \text{if } d'/x \leq 0.38 \quad \text{or}$$

$$A'_s = \frac{(K - K_{bal})f_{ck}bd^2}{f_{sc}(d - d')} \quad \text{if } d'/x > 0.38 \quad \text{where } f_{sc} = 700(1 - d'/x)$$

Calculate tension reinforcement:

$$A_s = \frac{K_{bal}f_{ck}bd^2}{0.87f_{yk}z} + A'_s \left(\frac{f_{sc}}{0.87f_{yk}} \right)$$

Design Procedure for Flanged Section

Supposed the bending moment is M , beam section is $b_w \times b \times d \times h_f$, concrete strength is f_{ck} and steel strength is f_{yk} , to determine the area of reinforcement, proceed as follows:

1. Calculate $M_f = 0.567 f_{ck} b h_f \left(d - \frac{h_f}{2} \right)$

2. If $M \leq M_f$, neutral axis lies in the flange

$$K = \frac{M}{f_{ck} b d^2}$$

$$z = d \left[0.5 + \sqrt{\left(0.25 - \frac{K}{1.134} \right)} \right]$$

$$A_s = \frac{M}{0.87 f_{yk} z}$$

3. If $M > M_f$, neutral axis lies in the web

$$\text{Calculate } \beta_f = 0.167 \frac{b_w}{b} + 0.567 \frac{h_f}{d} \left(1 - \frac{b_w}{b} \right) \left(1 - \frac{h_f}{2d} \right)$$

$$\text{Calculate } M_{bal} = \beta_f f_{ck} b d^2$$

Compare M with M_{bal}

4. If $M \leq M_{bal}$, compression reinforcement is not required

$$A_s = \frac{M + 0.1 f_{ck} b_w d (0.36d - h_f)}{0.87 f_{yk} \left(d - \frac{h_f}{2} \right)}$$

5. If $M > M_{bal}$, compression reinforcement is required

$$A'_s = \frac{(M - M_{bal})}{0.87 f_{yk} (d - d')}$$

$$A_s = \frac{0.167 f_{ck} b_w d + 0.567 f_{ck} h_f (b - b_w)}{0.87 f_{yk}} + A'_s$$

Minimum and Maximum Area of Reinforcement (Ref. Section 9.2: MS EN 1992-1-1: 2010)

The minimum area of reinforcement is given as:

$$A_{s,min} = 0.26 \left(\frac{f_{ctm}}{f_{yk}} \right) b d \text{ but not less than } 0.0013 b d$$

and the maximum area of reinforcement is given as:

$$A_{s,max} = 0.04 A_c = 0.04 b h$$

7.0 DESIGN FOR SHEAR (Ref. Section 6.2: MS EN 1992-1-1: 2010)

Members Requiring Design Shear Reinforcement

The following procedure can be use for determining vertical shear reinforcement.

1. Determine design shear force V_{Ed}
2. Determine the concrete strut capacity, $V_{Rd, max}$ for $\cot \theta = 1.0$ and $\cot \theta = 2.5$ ($\theta = 45^\circ$ and $\theta = 22^\circ$, respectively), where:

$$V_{Rd, max} = \frac{0.36f_{ck}b_w d \left(1 - \frac{f_{ck}}{250}\right)}{(\cot \theta + \tan \theta)}$$

3. If $V_{Ed} > V_{Rd, max}$ $\cot \theta = 1.0$, redesign the section
4. If $V_{Ed} < V_{Rd, max}$ $\cot \theta = 2.5$, use $\cot \theta = 2.5$, and calculate the shear reinforcement as follows

$$\frac{A_{sw}}{s} = \frac{V_{Ed}}{0.78f_{yk}d \cot \theta} = \frac{0.513V_{Ed}}{f_{yk}d}$$

5. If $V_{Rd, max}$ $\cot \theta = 2.5 < V_{Ed} < V_{Rd, max}$ $\cot \theta = 1.0$

$$\theta = 0.5 \sin^{-1} \left[\frac{V_{Ed}}{0.18b_w d f_{ck} \left(1 - \frac{f_{ck}}{250}\right)} \right]$$

Calculate shear link as

$$\frac{A_{sw}}{s} = \frac{V_{Ed}}{0.78f_{yk}d \cot \theta}$$

6. Calculate the minimum links required
7. Calculate the additional longitudinal tensile force caused by the shear

$$\Delta F_{td} = 0.5V_{Ed} \cot \theta$$

Procedure for Calculating Transverse Shear Reinforcement in Flanged Section

1. Calculate the longitudinal design shear stress, v_{Ed} at the web-flange interface:

$$v_{Ed} = \frac{\Delta F_d}{(h_f \cdot \Delta x)}$$

where $\Delta F_d = \frac{\Delta M}{\left(a - \frac{h_f}{2}\right)} \times \frac{\left(\frac{b_f - b_w}{2}\right)}{b_f}$ and ΔM is the change in moment over the distance Δx

2. If v_{Ed} is less than or equal to $0.4f_{ctd} = 0.4(f_{ctk}/1.5) = 0.27f_{ctk}$, then no shear reinforcement is required. Proceed to Step 4.
3. If v_{Ed} is more than $0.4f_{ctd} = 0.4(f_{ctk}/1.5) = 0.27f_{ctk}$, check the shear stresses in the incline strut. To prevent crushing of the concrete in the compressive struts the longitudinal shear stress is limited to:

$$v_{Ed} \leq \frac{0.4f_{ck} \left(1 - \frac{f_{ck}}{250}\right)}{(\cot \theta_f + \tan \theta_f)}$$

The lower value of the angle θ_f is first tried and if the shear stresses are too high the angle θ_f is calculated from the following equation:

$$\theta_f = 0.5 \sin^{-1} \left[\frac{v_{Ed}}{0.2f_{ck} \left(1 - \frac{f_{ck}}{250}\right)} \right] \leq 45^\circ$$

The permitted range of the values $\cot \theta_f$ is recommended as follows:

$$\begin{array}{ll} 1.0 \leq \cot \theta_f \leq 2.0 & \text{for compression flanges } (45^\circ \leq \theta_f \leq 26.5^\circ) \\ 1.0 \leq \cot \theta_f \leq 1.25 & \text{for tension flanges } (45^\circ \leq \theta_f \leq 38.6^\circ) \end{array}$$

4. Calculate the transverse shear reinforcement required as:

$$\frac{A_{sf}}{s_f} = \frac{v_{Ed} h_f}{0.87 f_{yk} \cot \theta_f}$$

Minimum Area of Reinforcement in the Flange

The minimum amount of transverse steel required in the flange is:

$$A_{s,min} = \frac{0.26 b h_f f_{ctm}}{f_{yk}} > 0.0013 b h_f \text{ mm}^2/m$$

where $b = 1000 \text{ mm}$

Sections Not Requiring Design Shear Reinforcement

In those sections where $V_{Ed} \leq V_{Rd,c}$ then no calculated shear reinforcement is required. The shear resistance of the concrete, $V_{Rd,c}$, in such situations is given by an empirical expression:

$$V_{Rd,c} = [0.12k(100\rho_1 f_{ck})^{1/3}] b_w d$$

with a minimum value of:

$$V_{Rd,c} = [0.035k^{3/2} f_{ck}^{1/2}] b_w d$$

where $k = \left(1 + \sqrt{\frac{200}{d}}\right) \leq 2.0$ with d expressed in mm

$$\rho_1 = \left(\frac{A_{s1}}{b_w d}\right) \leq 0.02$$

A_{s1} = the area of tensile reinforcement that extends $\geq (l_{bd} + d)$ beyond the section considered

b_w = the smallest width of the section in tensile area (mm).

8.0 DEFLECTION

(Ref. Section 7.4: MS EN 1992-1-1: 2010)

The equations to calculate the basic span-effective depth ratios, to control deflection to a maximum of span/250 are given as:

$$\frac{l}{d} = K \left[11 + 1.5\sqrt{f_{ck}} \frac{\rho_o}{\rho} + 3.2\sqrt{f_{ck}} \left(\frac{\rho_o}{\rho} - 1 \right)^{3/2} \right] \quad \text{if } \rho \leq \rho_o$$

$$\frac{l}{d} = K \left[11 + 1.5\sqrt{f_{ck}} \frac{\rho_o}{\rho - \rho'} + \frac{1}{12}\sqrt{f_{ck}} \sqrt{\frac{\rho'}{\rho}} \right] \quad \text{if } \rho > \rho_o$$

where l/d is the limiting span/depth

K is the factor to take into account the different in structural system from Table 7.4N

ρ_o is the reference reinforcement ratio = $\sqrt{f_{ck}} 10^{-3}$

ρ is the required tension reinforcement ratio = $\frac{A_{s,req}}{bd}$

ρ' is the required compression reinforcement ratio = $\frac{A_{s,req}'}{bd}$

Table 7.4N: Basic span/effective depth ratio (typical values for rectangular section for steel grade $f_{yk} = 500 \text{ N/mm}^2$ and concrete class C30/35)

Structural System	K	Basic span-effective depth ratio	
		Concrete highly stressed, $\rho = 1.5\%$	Concrete lightly stressed, $\rho = 0.5\%$
1. Simply supported beam, one/two way simply supported slab	1.0	14	20
2. End span of continuous beam or one-way continuous slab or two way spanning slab continuous over one long side	1.3	18	26
3. Interior span of beam or one way or two way spanning slab	1.5	20	30
4. Slab supported on columns without beam (flat slab) based on longer span	1.2	17	24
5. Cantilever	0.4	6	8

The basic ratios are modified in particular cases as follows:

- (i) For flange section where the ratio of the flange width to the web width exceeds 3, the values should be multiplied by 0.8.
- (ii) For beam and slabs, other than flat slab, with spans exceeding 7 m, which support partitions liable to be damaged by excessive deflection, the values should be multiplied by $7/\text{span}$.
- (iii) Where more tension reinforcement is provided ($A_{s,prov}$) than that calculated ($A_{s,req}$), multiply the values by = $\frac{A_{s,prov}}{A_{s,req}}$ (upper limit = 1.5).

9.0 CRACKING

(Ref. Section 7.3: MS EN 1992-1-1: 2010)

General Consideration

- (1) Cracking shall be limited to an extent that will not impair the proper functioning or durability of the structure or cause its appearance to be unacceptable.
- (2) Cracking is normal in reinforced concrete structures subject to bending, shear, torsion or tension resulting from either direct loading or restraint or imposed deformations.
- (3) Cracks may also arise from other causes such as plastic shrinkage or expansive chemical reactions within the hardened concrete. Such cracks may be unacceptably large but their avoidance and control lie outside the scope of this Section.
- (4) Cracks may be permitted to form without any attempt to control their width, provided they do not impair the functioning of the structure.

Note: The value of w_{max} for use in a Country may be found in its National Annex. The recommended values for relevant exposure classes are given in Table 7.1N.

Table 7.1N: Recommended values of w_{max} (mm)

Exposure Class	Reinforced Members and Prestressed Members without Unbonded Tendons	Prestressed Members with Bonded Tendons
	Quasi permanent load combination	Frequent load combination
X0, XC1	0.4 ¹	0.2
XC2, XC3, XC4	0.3	0.2 ²
XD1, XD2, XS1, XS2, XS3		Decompression
<p>Note 1: For X0, XC1 exposure classes, crack width has no influence on durability and this limit is set to give generally acceptable appearance. In the absence of appearance conditions this limit may be relaxed.</p> <p>Note 2: For these exposure classes, in addition, decompression should be checked under the quasi-permanent combination of loads.</p>		

Minimum Reinforcement Area

Flexural cracking is generally controlled by providing a minimum area of tension reinforcement and limiting bar spacing or limiting bar sizes.

- (a) Minimum reinforcement area

$$A_{s,min} = \frac{k_c k f_{ct,eff} A_{ct}}{f_{yk}}$$

where k_c is the stress distribution coefficient (1.0 for pure tension, 0.4 for flexure)

k is the non-linear stress distribution coefficient

= 1.0 for webs with $h \leq 300$ mm or flanges < 300 mm wide

= 0.65 for webs $h \geq 800$ mm or flanges > 800 mm wide (interpolate for intermediate values)

$f_{ct,eff}$ is the tensile strength of concrete at time of cracking with a suggested minimum of 3 N/mm².

A_{ct} is the area of concrete within tensile zone – defined as that area which is in tension just before the initiation of the first crack.

Control of Cracking without Direct Calculation

(b) Maximum spacing of reinforcement

Cracking due to loading is minimized by ensuring that the maximum spacing between longitudinal reinforcing bars in beam is limited to that given in Table 7.2N.

Table 7.2N: Maximum bar spacing for crack control

Steel stress (N/mm ²)	Maximum bar spacing (mm)	
	$w_k = 0.4$ mm	$w_k = 0.3$ mm
160	300	300
200	300	250
240	250	200
280	200	150
320	150	100
360	100	50

where the steel stress, $f_s = \frac{f_{yk}}{1.15} \times \frac{g_k + 0.3q_k}{(1.35g_k + 1.5q_k)} \frac{1}{\delta}$

(c) Maximum bar size

Table 7.3N: Maximum bar diameters for crack control

Steel stress (N/mm ²)	Maximum bar size (mm)	
	$w_k = 0.4$ mm	$w_k = 0.3$ mm
160	40	32
200	32	25
240	20	16
280	16	12
320	12	10
360	10	8
400	8	6
450	6	5

where the steel stress, $f_s = \frac{f_{yk}}{1.15} \times \frac{g_k + 0.3q_k}{(1.35g_k + 1.5q_k)} \frac{1}{\delta}$

10.0 MOMENT AND SHEAR COEFFICIENT FOR CONTINUOUS BEAM

Approximate general solutions for the maximum bending moments and shearing forces in uniformly loaded beams of three or more spans are given in Table 3.5. This table is reproduced from BS 8110 Part 1: 1997.

Table 3.5: Moments and shear coefficients of continuous beam (Ref. BS 8110: Part 1: 1997)

Position	At outer support	Near middle of end span	At first interior support	At middle of interior spans	At interior supports
Bending moment	0	+0.09FL	-0.11FL	+0.07FL	-0.08FL
Shear force	0.45F	-	0.6F	-	0.55F

Note: Values apply where characteristic variable load does not exceed characteristic permanent load and variations in span length do not exceed 15% of the longest span. (F is the total design load on span, and L is the effective span)

SIMPLIFIED CURTAILMENT RULES FOR BEAM

(Ref. "How to design concrete structures using Eurocode 2", The Concrete Centre, 2010)

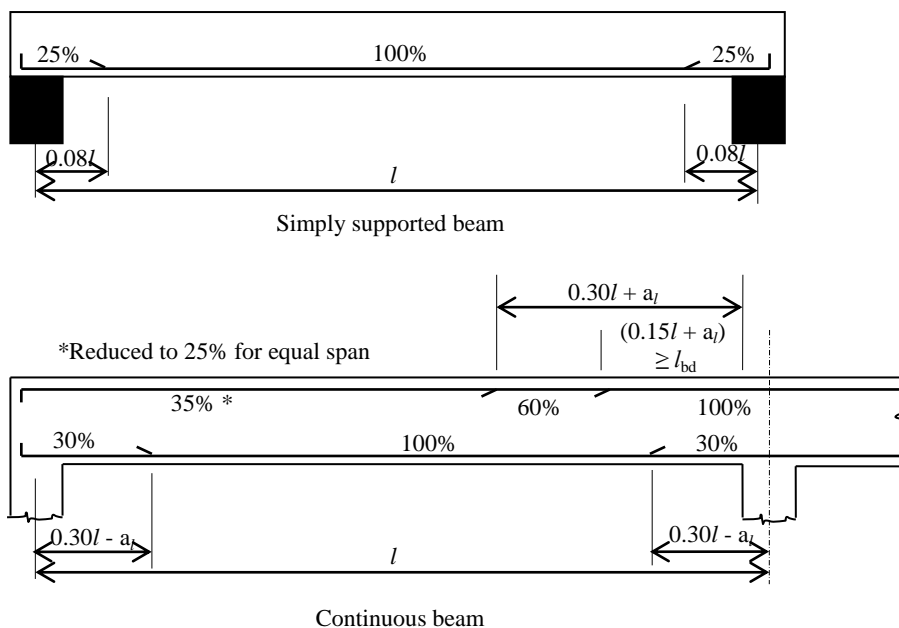

Figure 1: Simplified detailing rules for beams

Notes:

1. l is the effective length
2. a_t is the distance to allow for tensile force due to shear force = $z \cot \theta/2$. Can conservatively taken as $1.125d$
3. l_{bd} is the design anchorage length.
4. $q_k \leq g_k$
5. Minimum of two spans required
6. Applies to uniformly distributed loads only.
7. The shortest span must be greater than or equal to 0.85 times the longest span
8. Applies where 15% redistribution has been used.

11.0 MOMENT AND SHEAR COEFFICIENT FOR SOLID SLAB

Continuous One-way Slab

For slabs carrying uniformly distributed load and continuous over three or more nearly equal spans, approximate solution for the ultimate bending moments and shearing forces, are given in Table 3.12. This table is reproduced from BS 8110 Part 1: 1997.

Table 3.12: Ultimate moment and shear coefficients in continuous one way slab (Ref. BS 8110: Part 1: 1997)

	End support condition				At first interior support	Middle interior spans	Interior supports
	Pinned		Continuous				
	At outer support	Near middle of end span	At outer support	Near middle of end span			
Moment	0	$0.086FL$	$-0.04FL$	$0.075FL$	$-0.086FL$	$0.063FL$	$-0.063FL$
Shear	$0.4F$	–	$0.46F$	–	$0.6F$	–	$0.5F$

L = Effective span
 F = Total ultimate load = $1.35g_k + 1.5q_k$

Two-way Simply Supported Slab

A slab simply supported on its four sides with no provision has been made to prevent lifting or to resist the torsion then the moment coefficient of Table 3.13 may be used and the maximum moments are given by:

$$m_{sx} = \alpha_{sx} n l_x^2$$

$$m_{sy} = \alpha_{sy} n l_x^2$$

where n is the total ultimate load per unit area
 l_x is the length of shorter side
 l_y is the length of longer side
 α_{sx} and α_{sy} are the moment coefficient from Table 3.13

Table 3.13: Bending moment coefficient for simply supported two-way slab (Ref. BS 8110: Part 1: 1997)

l_y/l_x	1.0	1.1	1.2	1.3	1.4	1.5	1.75	2.0
α_{sx}	0.062	0.074	0.084	0.093	0.099	0.104	0.113	0.118
α_{sy}	0.062	0.061	0.059	0.055	0.051	0.046	0.037	0.029

Two-way Restrained Slab

When the slab are provided with different edge conditions like fixed or continuous edges, the maximum moments per unit width are given by:

$$m_{sx} = \beta_{sx} n l_x^2$$

$$m_{sy} = \beta_{sy} n l_x^2$$

where n is the total ultimate load per unit area
 l_x is the length of shorter side
 l_y is the length of longer side
 β_{sx} and β_{sy} are the moment coefficients from Table 3.14

Table 3.14: Bending moment coefficients for two-way restrained slab (*Ref. BS 8110: Part 1: 1997*)

Type of panel and moments considered	Short span coefficients, β_{sx}								Long span coefficient s, β_{sy} for all values of l_y/l_x
	Values of l_y/l_x								
	1.0	1.1	1.2	1.3	1.4	1.5	1.75	2.0	
Interior panels									
Negative moment at continuous edge	0.031	0.037	0.042	0.046	0.050	0.053	0.059	0.063	0.032
Positive moment at mid-span	0.024	0.028	0.032	0.035	0.037	0.040	0.044	0.048	0.024
One short edge discontinuous									
Negative moment at continuous edge	0.039	0.044	0.048	0.052	0.055	0.058	0.063	0.067	0.037
Positive moment at mid-span	0.029	0.033	0.036	0.039	0.041	0.043	0.047	0.050	0.028
One long edge discontinuous									
Negative moment at continuous edge	0.039	0.049	0.056	0.062	0.068	0.073	0.082	0.089	0.037
Positive moment at mid-span	0.030	0.036	0.042	0.047	0.051	0.055	0.062	0.067	0.028
Two adjacent edges discontinuous									
Negative moment at continuous edge	0.047	0.056	0.063	0.069	0.074	0.078	0.087	0.093	0.045
Positive moment at mid-span	0.036	0.042	0.047	0.051	0.055	0.059	0.065	0.070	0.034
Two short edges discontinuous									
Negative moment at continuous edge	0.046	0.050	0.054	0.057	0.060	0.062	0.067	0.070	–
Positive moment at mid-span	0.034	0.038	0.040	0.043	0.045	0.047	0.050	0.053	0.034
Two long edges discontinuous									
Negative moment at continuous edge	–	–	–	–	–	–	–	–	0.045
Positive moment at mid-span	0.034	0.046	0.056	0.065	0.072	0.078	0.091	0.100	0.034
Three edges discontinuous (one long edge continuous)									
Negative moment at continuous edge	0.057	0.065	0.071	0.076	0.081	0.084	0.092	0.098	–
Positive moment at mid-span	0.043	0.048	0.053	0.057	0.060	0.063	0.069	0.074	0.044
Three edges discontinuous (one short edge continuous)									
Negative moment at continuous edge	–	–	–	–	–	–	–	–	0.058
Positive moment at mid-span	0.042	0.054	0.063	0.071	0.078	0.084	0.096	0.105	0.044
Four edges discontinuous									
Positive moment at mid-span	0.055	0.065	0.074	0.081	0.087	0.092	0.103	0.111	0.056

Shear Force for Two-way Restrained Slab and Actions on Supporting Beams

The design shear forces of slab or loads on beams which supported the slabs can be evaluated using the equations below:

$$v_{sx} = \beta_{vx} n l_x$$

$$v_{sy} = \beta_{sy} n l_x$$

where n is the total ultimate load per unit area

l_x is the length of shorter side

β_{vx} and β_{vy} are the shear coefficients from Table 3.15

Table 3.15: Shear force coefficients for restrained two-way slab (Ref. BS 8110: Part 1: 1997)

Type of panel and location	β_{vx} for values of l_y/l_x								β_{vy}
	1.0	1.1	1.2	1.3	1.4	1.5	1.75	2.0	
Four edges continuous									
Continuous edge	0.33	0.36	0.39	0.41	0.43	0.45	0.48	0.50	0.33
One short edge discontinuous									
Continuous edge	0.36	0.39	0.42	0.44	0.45	0.47	0.50	0.52	0.36
Discontinuous edge	–	–	–	–	–	–	–	–	0.24
One long edge discontinuous									
Continuous edge	0.36	0.40	0.44	0.47	0.49	0.51	0.55	0.59	0.36
Discontinuous edge	0.24	0.27	0.29	0.31	0.32	0.34	0.36	0.38	–
Two adjacent edges discontinuous									
Continuous edge	0.40	0.44	0.47	0.50	0.52	0.54	0.57	0.60	0.40
Discontinuous edge	0.26	0.29	0.31	0.33	0.34	0.35	0.38	0.40	0.26
Two short edges discontinuous									
Continuous edge	0.40	0.43	0.45	0.47	0.48	0.49	0.52	0.54	–
Discontinuous edge	–	–	–	–	–	–	–	–	0.26
Two long edges discontinuous									
Continuous edge	–	–	–	–	–	–	–	–	0.40
Discontinuous edge	0.26	0.30	0.33	0.36	0.38	0.40	0.44	0.47	–
Three edges discontinuous (one long edge discontinuous)									
Continuous edge	0.45	0.48	0.51	0.53	0.55	0.57	0.60	0.63	–
Discontinuous edge	0.30	0.32	0.34	0.35	0.36	0.37	0.39	0.41	0.29
Three edges discontinuous (one short edge discontinuous)									
Continuous edge	–	–	–	–	–	–	–	–	0.45
Discontinuous edge	0.29	0.33	0.36	0.38	0.40	0.42	0.45	0.48	0.30
Four edges discontinuous									
Discontinuous edge	0.33	0.36	0.39	0.41	0.43	0.45	0.48	0.50	0.33

12.0 CRACKING RULES FOR SLAB

(Ref. Section 9.3: MS EN 1992-1-1: 2010)

To resist cracking of the concrete slabs, EC2 specify details such as minimum area of reinforcement required in a section and limits to the maximum and minimum spacing of bar.

- The minimum area of principal reinforcement is $A_{s,min} = \frac{0.26f_{ctm}b_t d}{f_{yk}}$ but not less than $0.0013b_t d$, where b_t is the mean width of the tension zone.
- The minimum area of secondary reinforcement is 20% A_s . In areas near support, transverse reinforcement is not necessary where there is no transverse bending moment.
- The spacing of principal reinforcement bars should not exceed three times the overall depth of slab ($3h$) or 400 mm whichever is the lesser. For secondary reinforcement the spacing should not exceed $3.5h$ or 450 mm whichever the lesser. These rules apply for slabs not exceeding 200 mm thick.

13.0 SIMPLIFIED CURTAILMENT RULES FOR SLAB

(Ref. "How to design concrete structures using Eurocode 2", The Concrete Centre, 2010)

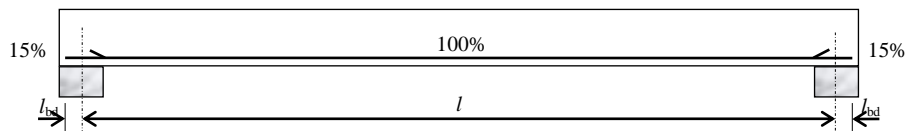

(a) Simply Supported

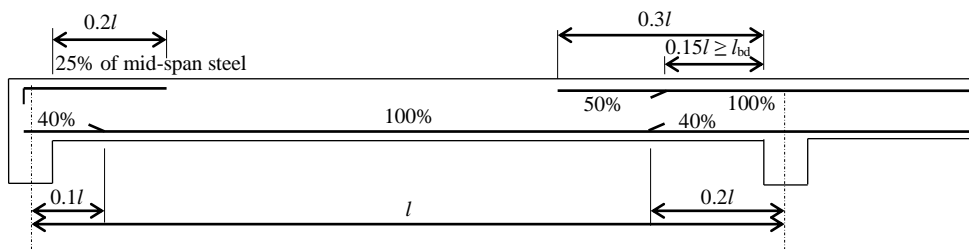

(b) Continuous

Figure 2: Simplified detailing rules for slabs

Notes

- l is the effective length
- l_{bd} is the design anchorage length.
- $q_k \leq 1.25g_k$ and $q_k \leq 5 \text{ kN/m}^2$
- Minimum of two spans required
- Applies to uniformly distributed loads only.
- The shortest span must be greater than or equal to 0.85 times the longest span
- Applies where 20% redistribution has been used.

14.0 PRESTRESSED MEMBERS AND STRUCTURES

Limitation of Concrete Stress (Ref. Section 5.10.2.2: MS EN 1992-1-1: 2010)

- (1) Local concrete crushing or splitting at the end of pre- and post-tensioned members shall be avoided.
- (2) Local concrete crushing or splitting behind post-tensioning anchors should be avoided in accordance with the relevant European Technical Approval.
- (3) The strength of concrete at application of or transfer of prestress should not be less than the minimum value defined in the relevant European Technical Approval.
- (4) If prestress in an individual tendon is applied in steps, the required concrete strength may be reduced. The minimum strength $f_{cm}(t)$ at the time t should be k_4 [%] of the required concrete strength for full prestressing given in the European Technical Approval. Between the minimum strength and the required concrete strength for full prestressing, the prestress may be interpolated between k_5 [%] and 100% of the full prestressing.

Note: The values of k_4 and k_5 for use in a Country may be found in its National Annex. The recommended value for k_4 is 50 and for k_5 is 30.

- (5) The concrete compressive stress in the structure resulting from the prestressing force and other loads acting at the time of tensioning or release of prestress, should be limited to:

$$\sigma_c \leq 0.6f_{ck}(t)$$

where $f_{ck}(t)$ is the characteristic compressive strength of the concrete at time t when it is subjected to the prestressing force. The limitation for both service and transfer condition are summarised in Table 1.

For pretensioned elements the stress at the time of transfer of prestress may be increased to $k_6f_{ck}(t)$, if it can be justified by tests or experience that longitudinal cracking is prevented.

Note: The value of k_6 for use in a Country may be found in its National Annex. The recommended value is 0.7.

If the compressive stress permanently exceeds $0.45f_{ck}(t)$ the non-linearity of creep should be taken into account.

Table 1: Limitation of Concrete Stress

Stresses	Loading Stage			
	Transfer		Service	
	Symbol	Value or Equation	Symbol	Value or Equation
Compressive	f_{ct}	$0.6f_{ck}(t)$	f_{cs}	$0.6f_{ck}$
Tensile	f_{tt}	f_{ctm}	f_{ts}	0

15. DESIGN OF COLUMNS

Slenderness ratio (Ref. Section 5.8.3.2 MS EN 1992:2010)

The slenderness ratio of a column bent about an axis is given by

$$\lambda = l_o/i = l_o / (I/A)^{1/2}$$

where

l_o	=	the effective length of the column
i	=	the radius of gyration about the axis considered
I	=	the second moment of area of the section about the axis
A	=	the cross-sectional area of the column

For columns in regular frames, an effective length can be determined in the following way:

Braced columns

$$l_o = 0.5l \sqrt{\left(1 + \frac{k_1}{0.45 + k_1}\right) \left(1 + \frac{k_2}{0.45 + k_2}\right)}$$

Unbraced columns

$$l_o = l \cdot \max \left\{ \sqrt{\left(1 + 10 \cdot \frac{k_1 \cdot k_2}{k_1 + k_2}\right)} ; \left(1 + \frac{k_1}{1 + k_1}\right) \cdot \left(1 + \frac{k_2}{1 + k_2}\right) \right\}$$

where

k_1, k_2	are the relative flexibilities of rotational restraints at ends 1 and 2 respectively
k	= column stiffness / Σ beam stiffness = $(EI/l)_{\text{column}} / \Sigma 2(EI/l)_{\text{beam}}$
l	is the clear height of compression member between end restraints at each end

Note: $k = 0$ is the theoretical limit for rigid rotational restraint, and $k = \infty$ represents the limit for no restraint at all. Since fully rigid restraint is rare in practise, a minimum value of 0,1 is recommended for k_1 and k_2 .

Slenderness Limit (Ref. Section 5.8.3.1 MS EN 1992:2010)

The upper limit on the slenderness ratio of a single column below which second order may be ignored is given by:

$$\lambda_{\text{lim}} = 20 \cdot A \cdot B \cdot C / \sqrt{n}$$

where

$$A = 1 / (1 + 0.2\varphi_{\text{eff}}) \quad : \varphi_{\text{eff}} = \text{effective creep ratio}$$

$$B = (1 + 2\omega)^{0.5} \quad : \omega = A_s f_{yd} / (A_c f_{cd})$$

$$C = 1.7 - r_m \quad : r_m = M_{o1} / M_{o2}$$

$$n = N_{\text{Ed}} / (A_c f_{cd})$$

N_{Ed} = the design ultimate axial load in the column

M_{o1}, M_{o2} are the first order moments at the end of the column with $|M_{o2}| \geq |M_{o1}|$

f_{yd} = the design yield strength of the reinforcement

f_{cd} = the design compressive strength of concrete

If φ_{eff} , ω , and r_m are not known, $A = 0.7$, $B = 1.1$ and $C = 0.7$ may be used.

The following conditions apply to the value of C:

- (a) If the end moments, M_{o1} and M_{o2} , give rise tension on the same side of the column, r_m should be taken as positive from which it follows that $C \leq 1.7$.
- (b) If the column is in a state of double curvature, then r_m should be taken as negative from which it follows that $C > 1.7$.
- (c) For braced members in which the first order moment arise only from or predominantly due to imperfections or transverse loading, r_m should be taken as 1.0 ($C = 0.7$)
- (d) For unbraced member in general, r_m should be taken as 1.0 ($C = 0.7$)

If the actual slenderness ratio is less than the calculated value of λ_{lim} then the column can be treated as short. Otherwise the column must be treated as slender and second order effects must be accounted for in the design of the column.

Longitudinal Reinforcement (Ref. Section 9.5.2 MS EN 1992:2010)

The minimum area of longitudinal reinforcement required in column is given by

$$A_{s,min} = 0.10N_{Ed}/f_{yd} \text{ or } 0.002A_c \text{ whichever the greater.}$$

The recommended minimum diameter of longitudinal reinforcement in columns is 12 mm. A minimum of four bars required in a rectangular column and six bars in a circular column.

The maximum area of reinforcement should not exceed 4% outside lap locations. However at laps 8% is permitted.

Transverse Reinforcement (Ref. Section 9.5.3 MS EN 1992:2010)

The diameter of links should not be less than 6 mm or one-quarter of the diameter of the largest longitudinal bar. The maximum spacing of links in columns should not exceed.

- 20 times the minimum diameter of the longitudinal bars
- the lesser dimension of the column
- 400 mm

At the distance within the larger dimension of the column above or below a beam or slab and near lapped joints these spacing should be reduced by a factor of 0.6. Every longitudinal bar or bundle of bars placed in a corner should be held by transverse reinforcement. No bar within compression zone should be further than 150 mm from a restrained bar.

Design Moments (Ref. Section 5.8.7 MS EN 1992:2010)

The design moment is;

$$M_{Ed} = M_{0Ed} + M_2$$

where:

$$\begin{aligned} M_{0Ed} &= \text{The 1}^{st} \text{. order moment including the effect of imperfection} \\ M_2 &= \text{The nominal 2}^{nd} \text{. order moment.} \end{aligned}$$

For braced slender column:

$$M_{Ed} = \text{Max}\{M_{o2}, M_{oE} + M_2, M_{o1} + 0.5M_2\}$$

For unbraced slender column;

$$M_{Ed} = \text{Max}\{M_{o1} + M_2, M_{o1} + M_2\}$$

where,

$$M_{o1} = \text{Min}\{ |M_{top}|, |M_{bot}| \} + N_{Ed} \cdot e_1$$

$$M_{02} = \text{Max} \{ |M_{\text{top}}|, |M_{\text{bot}}| \} + N_{\text{Ed}} \cdot e_1$$

N_{Ed} = The ultimate axial load

$$e_1 = l_o/400 \text{ units to be in mm}$$

$M_{\text{top}}, M_{\text{bot}}$ = Moments at the top and bottom of the column

$$M_{0E} = 0.6M_{02} + 0.4M_{01} \geq 0.4M_{02}$$

M_{01} and M_{02} should have the same sign if they give tension on the same side, otherwise opposite sign.

M_2 = The nominal second order moment = $N_{\text{Ed}} e_2$

$$e_2 = \text{The deflection} = (1/r)l_o^2/c$$

l_o = The effective length

c = A factor depending on the curvature distribution, normally $\pi^2 \approx 10$

$$1/r = \text{The curvature} = K_r \cdot K_\phi \cdot 1/r_o$$

K_r = axial load correction factor = $(n_u - n)/(n_u - n_{\text{bal}}) < 1$

where, $n = N_{\text{Ed}}/(A_c f_{\text{cd}})$, $n_u = 1 + w$, $n_{\text{bal}} = 0.4$

$$w = A_s f_{\text{yd}} / (A_c f_{\text{cd}})$$

K_ϕ = creep correction factor = $1 + \beta \phi_{\text{ef}} \geq 1$

where, ϕ_{ef} = effective creep ratio = $jM_{oE\text{qp}}/M_{oEd}$

$$= 0 \text{ if } (\phi < 2, M/N > h, 1 < 75)$$

$$\beta = 0.35 + f_{\text{ck}}/200 - \lambda/150 \quad (\lambda = \text{slenderness ratio})$$

$$1/r_o = \varepsilon_{\text{yd}}/(0.45d) = (f_{\text{yd}}/E_s)/(0.45d) =$$

Short column can be design ignoring second order effects and therefore the ultimate design moment, $M_{\text{Ed}} = M_2$

Biaxial Bending (Ref. Section 5.8.9 MS EN 1992:2010)

Biaxial bending need not be considered if

- (a) $\lambda_y/\lambda_z \leq 2$ and $\lambda_z/\lambda_y \leq 2$, and
 (b) $[(e_y/h_{\text{eq}})/(e_z/b_{\text{eq}})] \leq 0.2$ or $[(e_z/b_{\text{eq}})/(e_y/h_{\text{eq}})] \leq 0.2$

where

b, h are the width and depth of a section

$b_{\text{eq}} = i_y \cdot \sqrt{12}$ and $h_{\text{eq}} = i_z \cdot \sqrt{12}$ for an equivalent rectangular section

λ_y, λ_z are the slenderness ratio with respect to y- and z- axis respectively

$e_y = M_{\text{Edz}}/N_{\text{Ed}}$; eccentricity along y-axis

$e_z = M_{\text{Edy}}/N_{\text{Ed}}$; eccentricity along z-axis

M_{Edy} is the design moment about y-axis. Including second order moment

M_{Edz} is the design moment about z-axis. Including second order moment

N_{Ed} is the design value of axial load in the respective load combination

Figure 1: Definition of eccentricities e_y and e_z

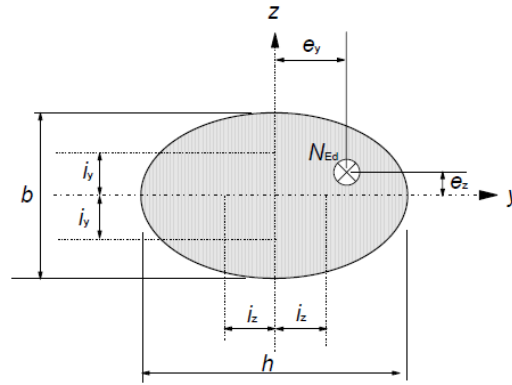

If the above conditions are not fulfilled, biaxial bending should be taken into account including the second order effects in each direction. The following simplified criterion may be used:

$$\left(\frac{M_{Edz}}{M_{Rdz}} \right)^a + \left(\frac{M_{Edy}}{M_{Rdy}} \right)^a \leq 1.0$$

where

M_{Rdy} is the moment resistance in y-axis. Including second order moment

M_{Rdz} is the moment resistance in z-axis. Including second order moment

a is the exponent;

for circular and elliptical cross section: $a = 2$

for rectangular cross sections :

$\bar{N}_{Ed}/\bar{N}_{Rd}$	0.1	0.7	1.0
a	1.0	1.5	2.0

with linear interpolation for intermediate values

$$N_{Rd} = A_c f_{cd} + A_s f_{yd}, \text{ design axial resistance of section}$$

A_c is the gross area of the concrete section

A_s is the area of longitudinal reinforcement

Biaxial bending column may be design using the method presented in BS 8110. The method specifies that a column subjected to an ultimate load N_{Ed} and moments M_z and M_y may be designed for a single axis bending but with an increase moment as follows;

(a) if $M_z/h' \geq M_y/b'$

then the increased single axis design moment is

$$M_z' = M_z + \beta (h'/b') M_y$$

(b) if $M_z/h' \leq M_y/b'$

then the increased single axis design moment is

$$M_y' = M_y + \beta (b'/h') M_z$$

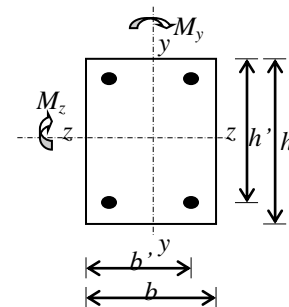

The coefficient β is specified in Table 1 or can be obtained from the equation

$$\beta = 1 - (N_{Ed}/bhf_{ck})$$

Table 1 : Values of coefficient β for biaxial bending

N_{Ed}/bhf_{ck}	0	0.1	0.2	0.3	0.4	0.5	0.6	0.7	≥ 0.75
β	1.00	0.91	0.81	0.72	0.63	0.53	0.44	0.35	0.3

Column design chart

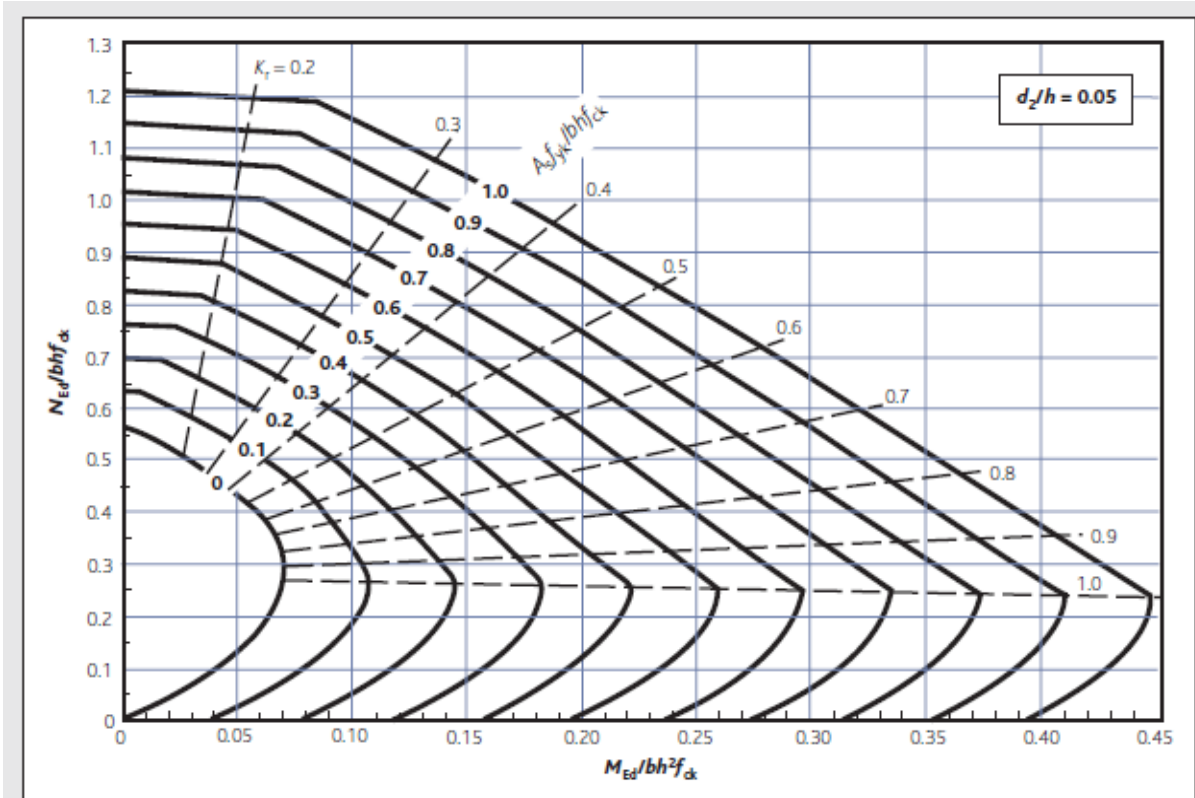

Figure 15.5a)
Rectangular columns $d_2/h = 0.05$

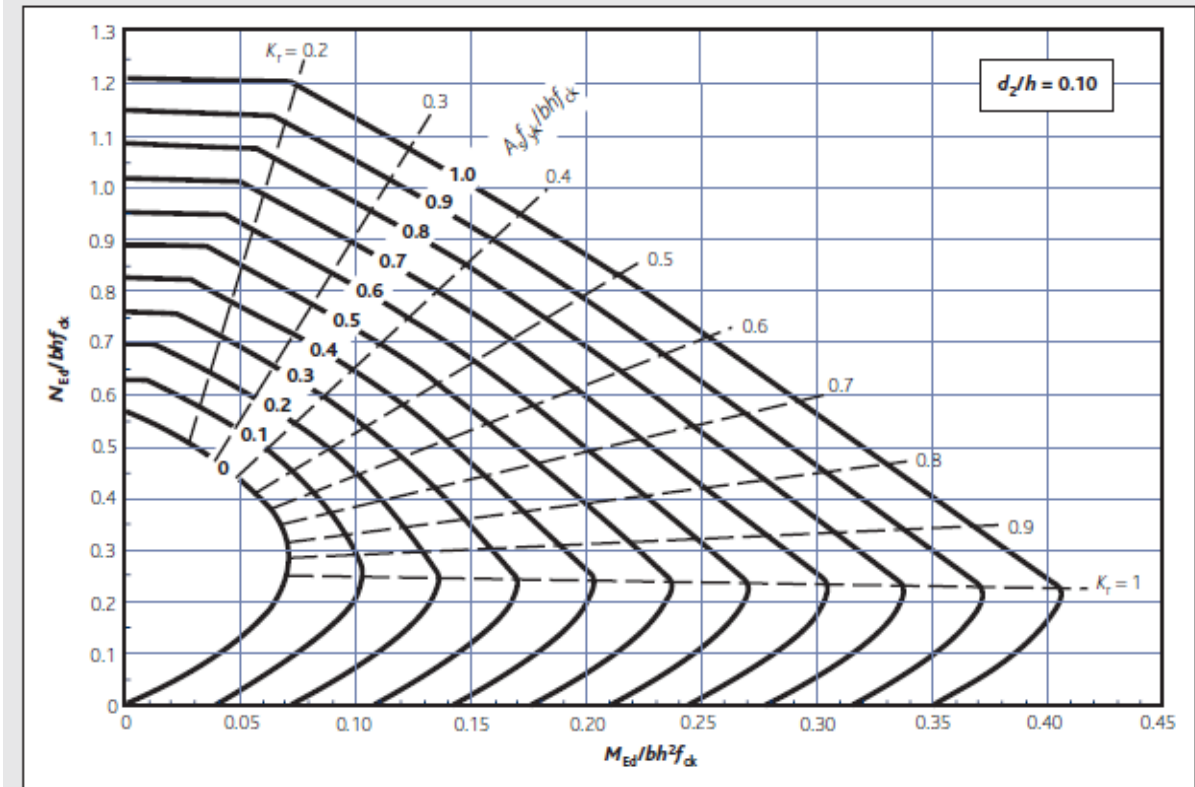

Figure 15.5b)
Rectangular columns $d_2/h = 0.10$

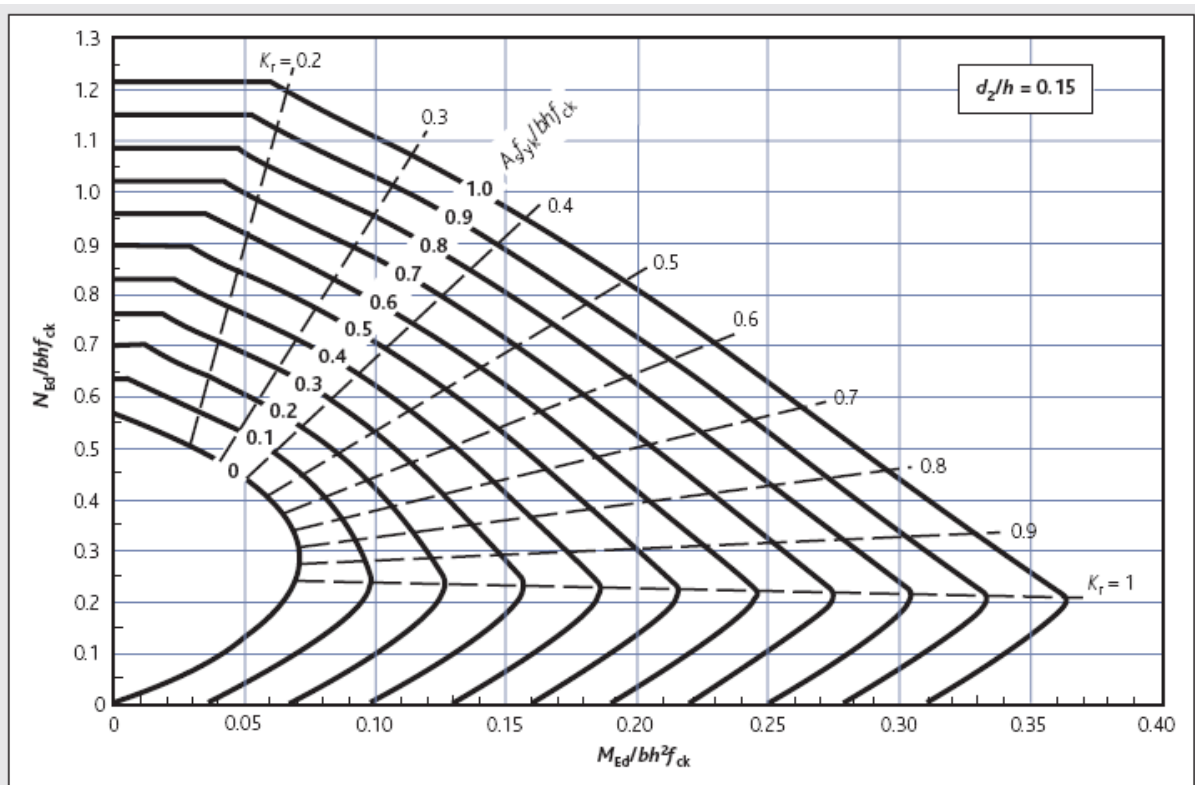

Figure 15.5c)
Rectangular columns $d_2/h = 0.15$

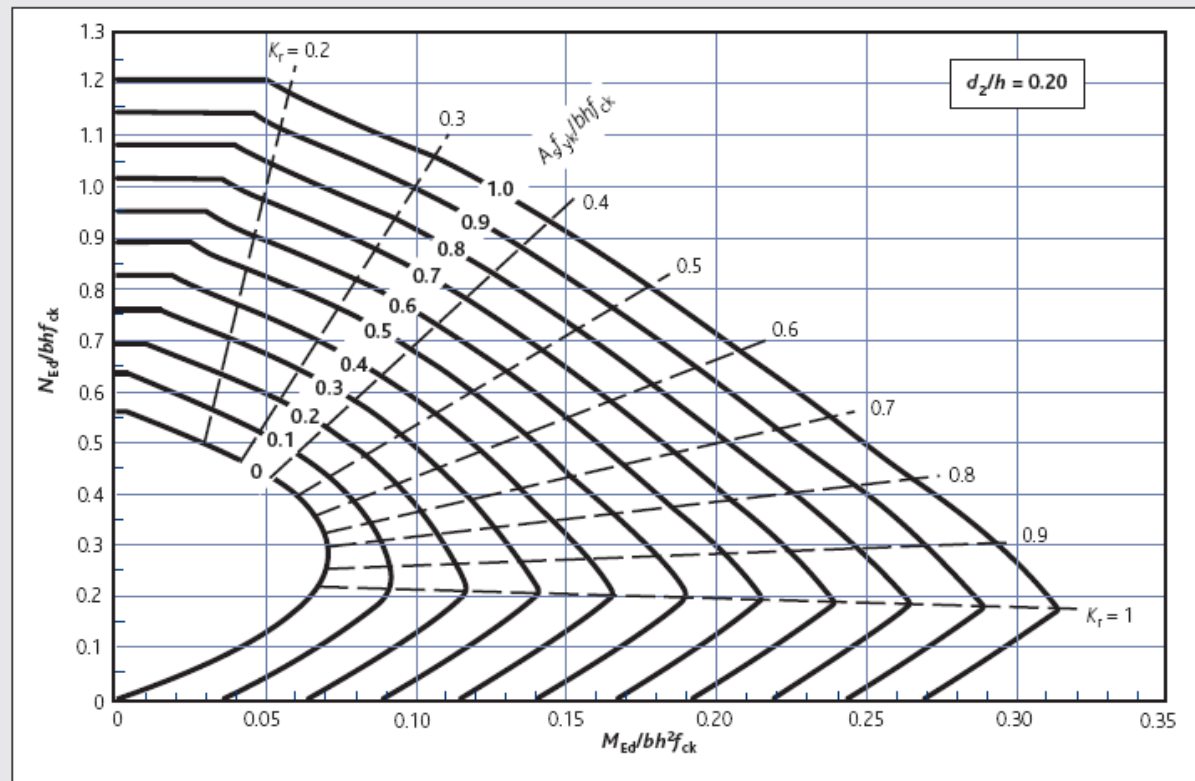

Figure 15.5d)
Rectangular columns $d_2/h = 0.20$

16.0 FRAME ANALYSIS

Method of Analysis (Ref. Section 5.1 MS EN 1992:2010)

Code of practices permit the use of approximate analysis techniques in which the structure can be considered as a series of sub-frames. EC 2 does not specifically describe the extent to which various columns and beams are included in the sub-frames. The methods of sub-frames analysis discussed here are based on BS 8110.

i. One-level Sub-frame

Each sub-frame may be taken to consist of the beams at one level together with the columns above and below. The ends of the columns remote from the beams may generally be assumed to be fixed unless the assumption of a pinned end is clearly more reasonable (for example, where a foundation detail is considered unable to develop moment restraint)

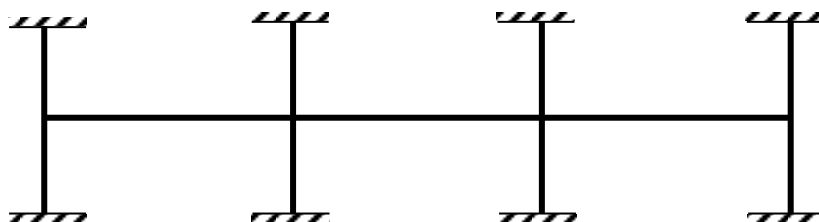

Sub-frame for analysis of beams and columns

ii. Two-points Sub-frame

The moments and forces in certain individual beam may be found by considering a simplified sub-frame consisting only of that beam, the columns attached to the end of that beam and the beams on either side, if any. The column and beam ends remote from the beam under consideration may generally be assumed to be fixed unless the assumption of pinned is clearly more reasonable. The stiffness of the beams on either side of the beam considered should be taken as half their actual values if they are taken to be fixed at their outer ends.

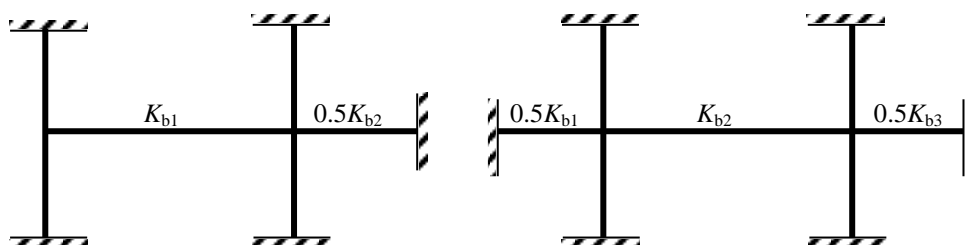

Sub-frame for analysis of individual beam

iii. Continuous beam and one-point sub-frame

The moments and forces in the beams at one level may also be obtained by considering the beams as a continuous beam over supports providing no restraint to rotation.

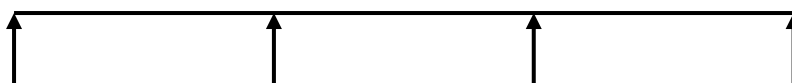

Continuous beam for analysis of beams

The ultimate moments for column may be calculated by simple moment distribution procedures, on the assumption that the column and beam ends remote from the junction under consideration are fixed and that the beams possess half their actual stiffness. The arrangement of the design ultimate variable loads should be such as to cause the maximum moment the column.

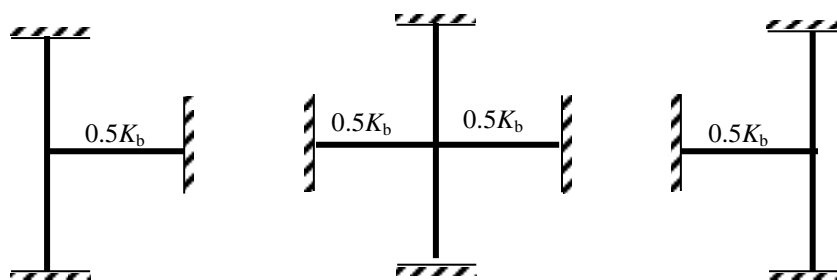

One-point sub-frames for analysis of columns

Load Cases and Combination (Ref. Section 5.1.3 MS EN 1992:2010)

Separate actions or loads must be applied to the structure in appropriate directions and various types of actions combined with partial safety factors selected to cause the most severe design condition for the member under consideration. In general the following combination of actions should be investigated.

Load set 1: Adjacent or alternate spans loaded

- i. any two adjacent spans carrying the design variable and permanent loads ($1.35G_k + 1.5Q_k$),: all other spans carrying only the design permanent load ($1.35G_k$)
- ii. alternate span carrying the design variable and permanent load ($1.35G_k + 1.5Q_k$), other spans carrying only the design permanent loads ($1.35G_k$)

Load set 2: Alternate or all spans loaded

- i. alternate span carrying the design variable and permanent load ($1.35G_k + 1.5Q_k$), other spans carrying only the design permanent loads ($1.35G_k$)
- ii. all span carrying the design variable and permanent loads ($1.35G_k + 1.5Q_k$).

Load Set 1 is the recommended arrangement given by EC2: Section 5.1.3. Malaysian National Annex allows the use of Load Set 2 which requires only three load cases that need to be assessed.

Analysis of Frame for Lateral Loads

The two popular approximate method of analysis for lateral loads are portal method and cantilever method.

In the portal method, the frame is theoretically divided into independent portals. The shear in each storey is assumed to be divided between the bays in proportion to their spans. The shear in each bay is then divided equally between the columns. The column end moments are the column shear multiplied by one-half the column height. Beam moments balance the column moments. The external column only resist axial load which is found by dividing the overturning moment at any level by the width of the building.

In cantilever method the axial loads in column are assumed to be proportion to the distance from the centre of gravity of the frame. It is also usual to assume that all the column in a storey are of equal cross-sectional area and the point of contraflexure are located at the mid-points of all columns and beams.

Calculation of Wind Load

Three procedures are specified in MS 1553: 2002 for the calculation of wind pressures on buildings: *the simplified procedure*, limited in application to buildings of rectangular in plan and not greater than 15.0 m high; *analytical procedure*, limited to regular buildings that are not more than 200 m high and structure with roof spans less than 100 m; and the *wind tunnel procedure*, used for complex buildings.

17.0 DESIGN OF FOUNDATIONS

(a) Design of pad footing

Thickness and size of footing

The total area at the base of the footing is determined from the point of view of the safe bearing capacity of soil. The thickness of footing is generally based on consideration of shear and flexure, which are critical near the column location.

Design for flexure

The footing base slab bends upward into a saucer-like shape on account of the soil pressure from below. The critical section of bending is at the face of the column. The moment is taken on a section passing completely across the footing and is due to the ultimate loads on one side of the section. The moment and shear forces should be assessed using STR combination:

$$N = 1.35G_k + 1.5Q_k \quad \text{STR combination 1 (Exp. 6.10 MS EN 1990)}$$

Check for shear (Ref. Section 6.4 MS EN 1992:2010)

Footing may fail in shear as beam shear or punching shear at the location shown in Figure 1

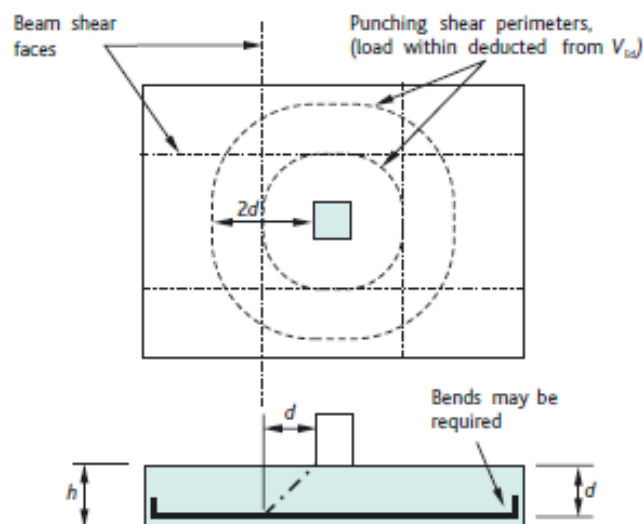

Figure 1: Location of critical shear section and perimeter

Vertical shear

The critical section for vertical shear is at distance d from the face of the column. The vertical shear force is the sum of the loads acting outside the section. If the design shear force V_{Ed} is less than the concrete shear resistance $V_{Rd,c}$ no shear reinforcement is required.

Punching shear

The critical section for punching shear is at a perimeter $2d$ from the face of column. The punching shear force is the sum of the loads outside the critical perimeter. The shear stress is $v_{Ed} = V_{Ed}/ud$ where u is the critical perimeter. If the shear stress v_{Ed} is less than the concrete shear resistance $v_{Rd,c}$ no shear reinforcement is required. The maximum punching shear at the column face must not exceed the maximum shear resistance V_{Rdmax} .

Punching shear resistance can be significantly reduced in the presence of a coexisting bending moment, M_{Ed} , transmitted to the foundation. To allow for the adverse effect of the moment, which gives rise to a non-uniform distribution of shear around the control perimeter Clause 6.4.3(3) of EC2 gives the design shear stress to be used in punching shear calculation as;

$$v_{Ed} = \beta \frac{V_{Ed}}{u_1 d}$$

where

β = factor used to include the effect of eccentric loads and bending moments

$$= 1 + k \frac{M_{Ed}}{V_{Ed}} \frac{u_1}{W_1}$$

k = coefficient dependent on the ratio between the column dimension (c_1 and c_2).

c_1/c_2	≤ 0.5	1.0	2.0	≥ 3.0
k	0.45	0.60	0.70	0.80

u_1 = the length of basic control perimeter

W_1 = function of the basic control perimeter corresponds to the distribution of shear

$$= 0.5c_1^2 + c_1c_2 + 4c_2d + 16d^2 + 2\pi dc_1$$

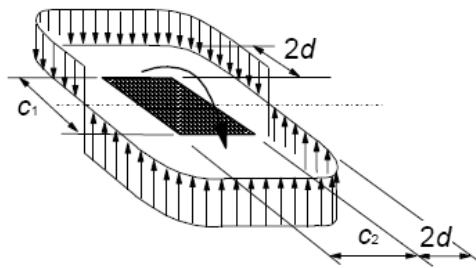

Figure 11.5: Shear distribution due to an unbalanced moment

Cracking and detailing requirements

Use the rules for slabs design or section 9.3 of MS EN 1992:2010

(b) Design of Pile Foundation

Determination of piles number and spacing

The number of piles required is determined based on the requirement that the pile load should not exceed the single pile capacity. Piles are usually arranged symmetrically with respect to the column axis. The pile loads are calculated as follows.

(i). Foundation subject to axial load only.

$$F_a = \frac{(N + W)}{n}$$

(ii). Foundation subject to axial load and moment

$$F_{ai} = \frac{(N + W)}{n} \pm \frac{Mx_i}{I_y}$$

Design of pile cap

Size and thickness

The size and thickness of pile cap depends on the number of piles used, the arrangement of piles and the shape of pile cap.

Main reinforcement

Pile caps are design either using bending theory or using the truss analogy.

Design for shear

The shear capacity of a pile cap should be checked at the critical section taken to be 20 % of the pile diameter inside the face of the pile. The whole of the force from the piles with centers lying outside this line should be considered.

In determining the shear resistance, shear enhancement may be considered such that the shear capacity of the concrete may be increase to $v_c \times 2d/a$ where a_v is the distance from the face of the column to the critical section. Where the spacing of the piles is less than or equal to three times the pile diameter, this enhancement may be applied across the whole critical section; otherwise it may be applied to strips of width of three times the pile diameter located central to each pile.

Where the spacing of the piles exceeds three times the pile diameter then the pile cap should be checked for punching shear on the perimeter shown in Figure 2. The shear force at the column face should be checked to ensure that it is less than $0.5v_1f_{cd}ud = 0.5v_1(f_{ck}/1.5)ud$ where u is the perimeter of the column and the strength reduction factor, $v_1 = 0.6(1 - f_{ck}/250)$.

Figure 2: Critical shear perimeter of pile cap

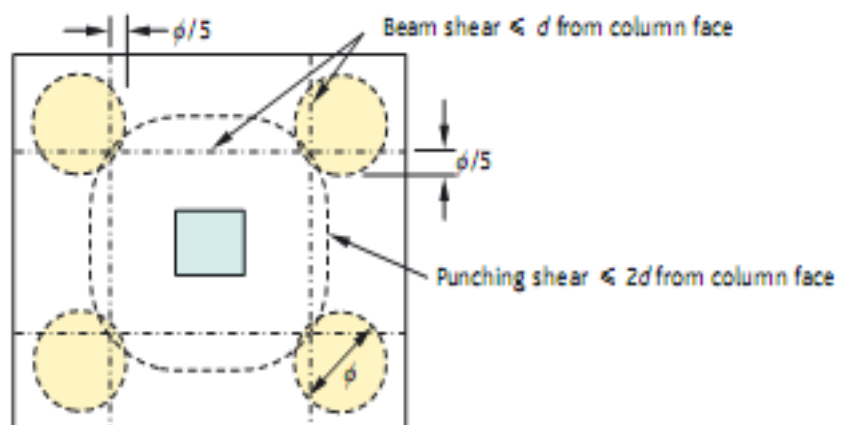

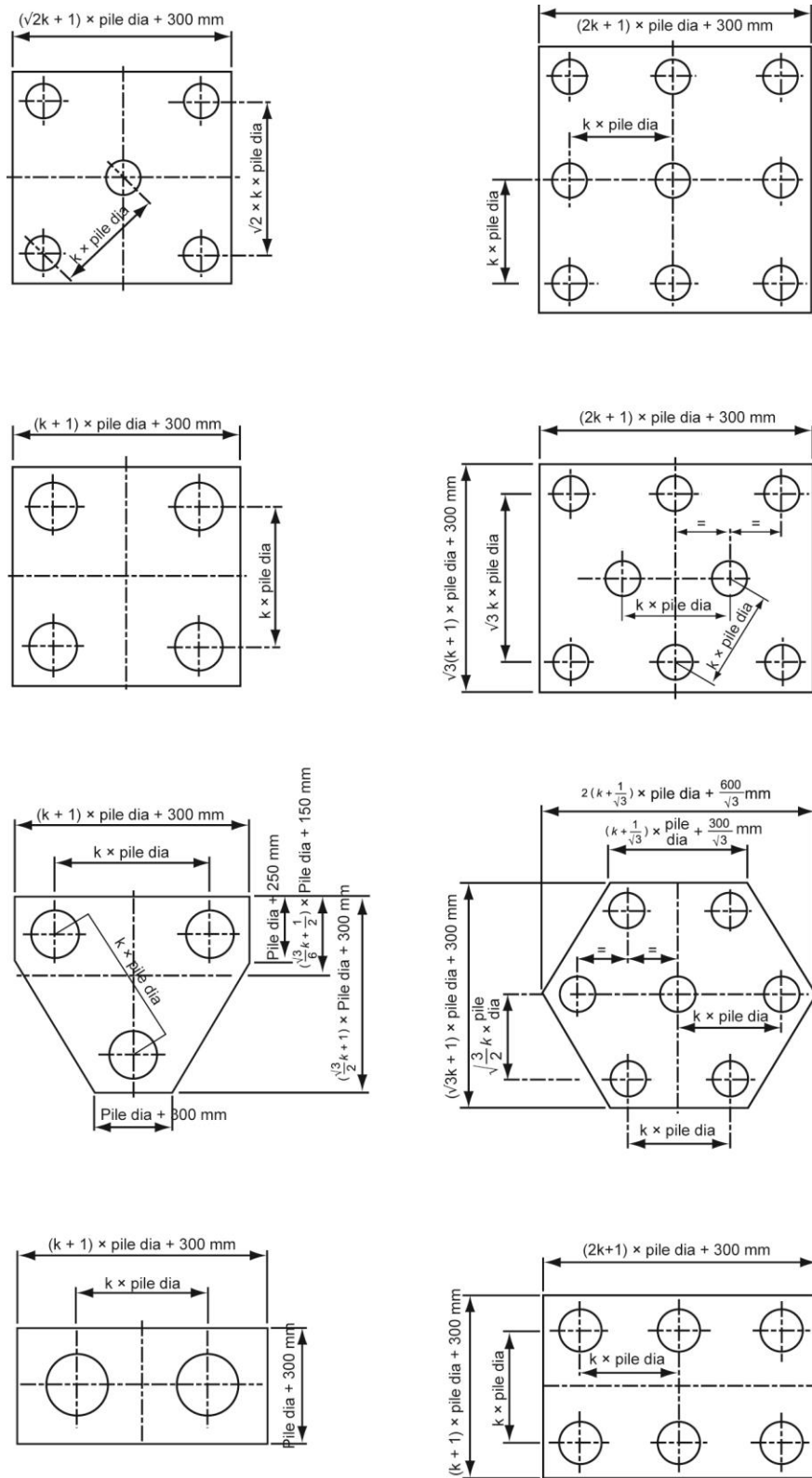

Figure 11.6 Typical size of pile cap
 (Source : "Pile design and construction practice", Tomlinson^[15])

Number of piles	Dimensions of pile cap	Neglecting of column	Tensile force to be resisted by reinforcement Taking size of column into consideration
2		$\frac{Nl}{4d}$	$\frac{N}{12ld}(3l^2 - a^2)$
3		$\frac{Nl}{9d}$	Parallel to X-X: $\frac{N}{36ld}(4l^2 + b^2 - 3a^2)$ Parallel to Y-Y: $\frac{N}{18ld}(2l^2 - b^2)$
4		$\frac{Nl}{8d}$	Parallel to X-X: $\frac{N}{24ld}(3l^2 - a^2)$ Parallel to Y-Y: $\frac{N}{24ld}(3l^2 - b^2)$
5		$\frac{Nl}{10d}$	Parallel to X-X: $\frac{N}{30ld}(3l^2 - a^2)$ Parallel to Y-Y: $\frac{N}{30ld}(3l^2 - b^2)$

Notation h_p diameter of pile; a, b dimensions of column; α spacing factor of piles (normally between 2 and 3 depending on ground conditions)

Figure 9.7 Tensile force in pile cap

(Source : "Reinforced concrete designers handbooks", Reynold^[11])

Design of reinforcement

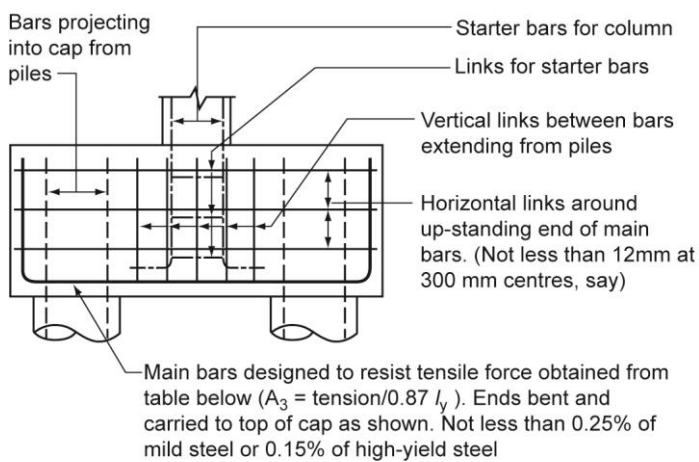

Figure 11.5 Detailing requirement of pile cap

18.0 DESIGN OF RETAINING WALLS

Stability analysis

The lateral force due to earth pressure constitutes the main force acting on the retaining wall, tending to make it overturn, slide and settle. So the safety of the wall depends on its stability against these three modes of failure under the ultimate limit state (EQU, STR and GEO) as defined in MS EN 1990:2010.

Three sets of load combinations must be considered at the ultimate limit state. The first two combinations will be used for consideration of both structural failure, STR, and geotechnical failure, GEO. The third combination must be taken when considering possible loss of equilibrium (EQU) of the structure such as overturning. The partial safety factors to be used for these three combinations are given in Table 1.

Table 1: Partial safety factor at the ultimate limit state

Persistent or transient design situation	Permanent actions		Leading variable action	Accompanying variable action
	Unfavourable	Favourable	Unfavourable	Unfavourable
(a) For consideration of structural or geotechnical failure: combination 1 (STR & GEO)	1.35	1.00	1.50 (0 if favourable)	1.50 (0 if favourable)
(b) For consideration of structural or geotechnical failure: combination 2 (STR & GEO)	1.00	1.00	1.30 (0 if favourable)	1.30 (0 if favourable)
(c) For checking static equilibrium (EQU)	1.10	0.90	1.50 (0 if favourable)	1.50 (0 if favourable)

Overturning

A partial safety factor of 0.9 is applied to the permanent vertical load ΣV_k (weight of wall + weight of soil) if its effect is 'favourable'. The 'unfavourable' effects of the permanent earth pressure loading H_k at the rear face of the wall are multiplied by a partial safety factor of 1.1. The 'unfavourable' effects of the variable surcharge loading, if any, are multiplied by a partial safety factor of 1.5. The stability requirement against overturning then becomes,

$$0.9(\Sigma V_k x) \geq \gamma_f H_k y$$

Sliding

A partial safety factor of $\gamma_f = 1.0$ is applied to the permanent vertical load ΣV_k if its effect is 'favourable' (i.e. contribute to the sliding resistance) and the 'unfavourable' effects of the permanent earth and surcharge pressures at the rear face of the wall are multiplied by partial safety factors of $\gamma_f = 1.35$ and 1.5 respectively. Thus, if the coefficient of friction between base and soil is μ , the stability requirement against sliding then becomes,

$$\mu(\gamma_f \Sigma V_k) \geq \gamma_f H_k$$

Settlement

The bearing pressure is then given by, $p = \Sigma N/A \pm \Sigma M/Z$. The maximum bearing pressure must be less than or equal to the soil bearing capacity. Two sets of load combinations must be considered at the ultimate limit state.

For load combination 1, the moment due to the horizontal load on the maximum bearing pressure at the toe of the wall is 'unfavourable' whilst the moments of the weight of the wall and the earth acting on the heel of the wall act in the opposite sense and are thus 'favourable'. Hence the partial safety factor for the lateral earth

pressure and lateral surcharge are 1.35 and 1.5 respectively, whilst the partial safety factor for the effect of weight of wall and soil is 1.0 and the partial safety factor for the weight of surcharge is 0.

For load combination 2, the partial safety factor for permanent action is 1.0 for both 'unfavourable' and 'favourable' effects and the partial safety factor for variable action is 1.3 and 0 for unfavourable and favourable effects respectively.

Element design and detailing

The three elements of the retaining wall, ie stem, toe slab and heel slab have to be designed as cantilever slabs to resist the designed moments and shear forces.

The stem is designed to resist the moment caused by the force $\gamma_f H_f$, with γ_f values taken for load combination 1 if this load combination is deemed to be critical. The flexural reinforcement is provided near the rear face of the stem, and may be curtailed in stages for economy.

In the case of toe slab, the net pressure is obtained by deducting the weight of the concrete in the toe slab from the upward acting soil pressure. The net pressure acts upward and the flexural reinforcement has to be provided at the bottom of toe slab.

The heel slab must be designed to resist the moment due to downward pressure from the weight of the retained earth (plus surcharge, if any) and concrete slab. Since the net pressure acts downward, the flexural reinforcement has to be provided at the top of the heel slab.

The partial safety factor γ_{f1} , γ_{f2} and γ_{f3} should be taken to provide a combination which gives the critical designed conditions i.e the worst of combination 1 and 2. Temperature and shrinkage reinforcement should be provided transverse to the main reinforcement.

19.0 BAR AREAS

Table A: Sectional areas of groups of bars (mm²)

Bar size (mm)	Number of bars									
	1	2	3	4	5	6	7	8	9	10
6	28.3	56.6	84.8	113	141	170	198	226	255	283
8	50.3	101	151	201	251	302	352	402	452	503
10	78.6	157	236	314	393	471	550	628	707	786
12	113	226	339	452	566	679	792	905	1018	1131
16	201	402	603	804	1005	1207	1408	1609	1810	2011
20	314	628	943	1257	1571	1885	2199	2514	2828	3142
25	491	982	1473	1964	2455	2946	3437	3928	4418	4909
32	804	1609	2413	3217	4022	4826	5630	6435	7239	8044
40	1257	2514	3770	5027	6284	7541	8798	10054	11311	12568

Table B: Sectional area per meter width for various bar spacing (mm²/m)

Bar size (mm)	Spacing of bars									
	50	75	100	125	150	175	200	225	250	300
6	566	377	283	226	189	162	141	126	113	94
8	1005	670	503	402	335	287	251	223	201	168
10	1571	1047	786	628	524	449	393	349	314	262
12	2262	1508	1131	905	754	646	566	503	452	377
16	4022	2681	2011	1609	1341	1149	1005	894	804	670
20	6284	4189	3142	2514	2095	1795	1571	1396	1257	1047
25	9819	6549	4909	3928	3273	2805	2455	2182	1964	1636
32	16087	10725	8044	6435	5362	4596	4022	3575	3217	2681
40	25136	16757	12568	10054	8379	7182	6284	5586	5027	4189

STANDARD FABRIC

BS 4483:1985

BRC Ref. No.		Cross-sectional area (mm ² /m)		Wire diameter (mm)		Wire spacing (mm)		Nominal mass (kg)
		Main	Cross	Main	Cross	Main	Cross	
SQUARE FABRIC								
A10	A393	393	393	10	10	200	200	6.17
A8	A252	251	251	8	8	200	200	3.95
A7	A192	192	192	7	7	200	200	3.02
A6	A142	141	141	6	6	200	200	2.22
A5	A98	98	98	5	5	200	200	1.54
STRUCTURAL MESH								
B12	B1131	1131	251	12	8	100	200	10.86
B10	B786	786	251	10	8	100	200	8.15
B8	B503	503	251	8	8	100	200	5.92
B7	B385	385	192	7	7	100	200	4.54
B6	B283	283	192	6	7	100	200	3.73
B5	B196	196	192	5	7	100	200	3.05
LONG MESH								
C10	C785	786	71	10	6	100	400	6.73
C9	C636	636	71	9	6	100	400	5.55
C8	C503	503	49	8	5	100	400	4.34
C7	C385	385	49	7	5	100	400	3.41
C6	C283	283	49	6	5	100	400	2.61
WRAPPING MESH								
D98	D98	98	98	5	5	200	200	1.54
D49	D49	49	49	2.5	2.5	100	100	0.77