

CROSS HATCH LINE DIMENSIONS
NOTE: TYPE SHALL BE AS PER PLAN. DEFAULT VALUE IS TYPE C UNLESS OTHERWISE SHOWN.

POSTED SPEED ≥ 45 MPH					POSTED SPEED < 45 MPH				
TYPE	W	θ°	S	L	TYPE	W	θ°	S	L
A	1'	30°	3'	8'	A	8"	30°	2'	5'-4"
B	1'	35°	3'	7'	B	1'	35°	3'	7'
C	2'	45°	6'	11'-4"	C	2'	45°	6'	11'-4"

CROSS HATCHED ISLAND DETAIL
SHOWN FOR RADIUS TAPER
STRAIGHT TAPER STRIPING SIMILAR

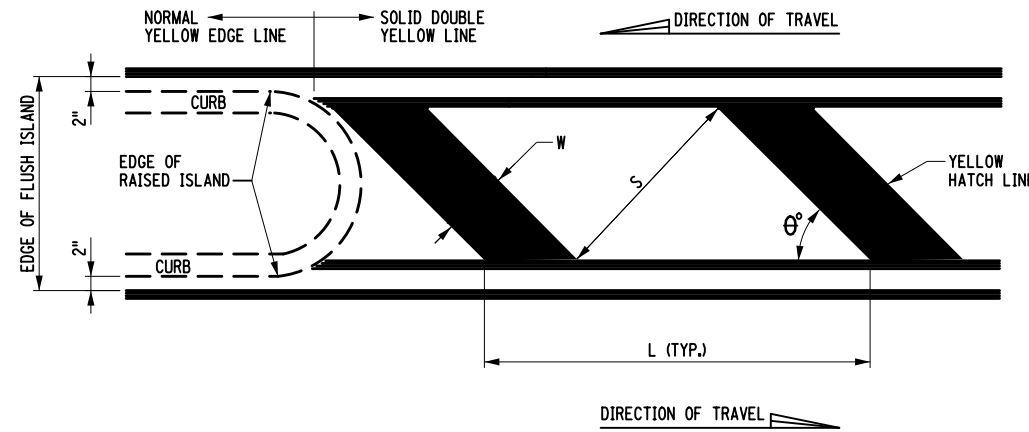

TYPICAL CROSS HATCH LINE DETAIL AT FLUSH OR RAISED ISLANDS
AND AT MEDIAN AREAS

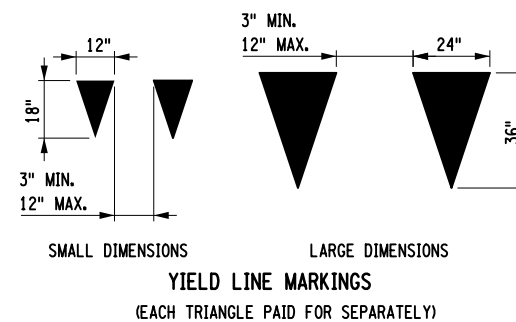

GENERAL PAVEMENT MARKING NOTES:

- ALL PAVEMENT MARKINGS SHALL BE PLACED IN ACCORDANCE WITH THE MUTCD AND NYS SUPPLEMENT.
- EDGE LINES SHALL BE YELLOW ON THE LEFT SIDE AND WHITE ON THE RIGHT SIDE IN THE DIRECTION OF TRAVEL UNLESS OTHERWISE SHOWN ON THE PLANS. IF THE CURB OFFSET IS LESS THAN 2'-0", NO EDGE LINE SHALL BE APPLIED ADJACENT TO CURBS UNLESS OTHERWISE SHOWN ON THE PLANS. EDGE LINES SHALL BE PROVIDED AT THE CURB ADJACENT TO RAISED ISLANDS (SEE DETAIL).
- WHERE MARKINGS NORMALLY FOLLOW A PAVEMENT JOINT, SINGLE LINE MARKINGS SHALL BE PLACED ALONG ONE SIDE OF THE JOINT. DOUBLE LINE MARKINGS SHALL STRADDLE THE JOINT. LANE LINES ON ROADWAYS WHICH ARE MORE THAN TWO LANES WIDE AND HAVE LONGITUDINAL JOINTS BETWEEN ADJACENT LANES, SHALL BE PLACED ON THE SIDE OF THE JOINT WHICH WILL OBTAIN OPTIMUM LANE WIDTHS.

AT THE JUNCTION OF SINGLE AND DOUBLE LINE MARKINGS WHICH FOLLOW A PAVEMENT JOINT, THE SINGLE LINE SHALL BE AN EXTENSION OF EITHER OF THE DOUBLE LINES AND NOT THE SPACE BETWEEN THEM. AT THE JUNCTION OF SINGLE AND DOUBLE LINE MARKINGS WHICH DO NOT FOLLOW A PAVEMENT JOINT, THE SINGLE LINE MAY BE ALIGNED WITH THE CENTER OF THE DOUBLE LINE MARKING OR WITH EITHER LINE OF THE DOUBLE LINE.
- ALL DIMENSIONS AND THE PLACEMENT OF ARROWS, SYMBOLS, AND TEXT ARE TYPICAL AND SHALL APPLY UNLESS OTHERWISE INDICATED IN THE CONTRACT DOCUMENTS.
- THE REGIONAL TRAFFIC ENGINEER WILL REVIEW AND APPROVE ANY CHANGES TO THE PAVEMENT MARKING PLANS PRIOR TO FINAL INSTALLATION. CHANGES SHALL BE SUBMITTED TWO WEEKS PRIOR TO INSTALLATION.

PAVEMENT MARKING LINE NOTES:

- NORMAL PAVEMENT MARKING LINES SHALL BE 6" ON FREEWAYS AND EXPRESSWAYS AND ON RAMPS TO AND FROM FREEWAYS AND EXPRESSWAYS, AND WHERE SPECIFIED IN THE CONTRACT DOCUMENTS. AT ALL OTHER LOCATIONS NORMAL PAVEMENT MARKING LINES SHALL BE 4". WIDE PAVEMENT MARKING LINES SHALL BE TWICE AS WIDE AS NORMAL LINES ON THE SAME HIGHWAY. CHANNELIZING LINES ARE THE SAME WIDTH AS WIDE LINES.
- PAVEMENT MARKING LINE CODES MAY BE SHOWN ON THE PLANS.

DESIGNATIONS:
"W"-WHITE "Y"-YELLOW "WIDE"-WIDE



U.S. CUSTOMARY STANDARD SHEET

PAVEMENT_MARKING_DETAILS
(SHEET 1 OF 9)

APPROVED SEPTEMBER 24, 2012

/S/ TODD B. WESTHUIS, P.E.

ACTING DIRECTOR, OFFICE OF
TRAFFIC SAFETY AND MOBILITY

ISSUED UNDER EB 12-036

685-01

ERRATA 1
ISSUED WITH EB 17-041

FILE NAME = 685-0103_050213.dgn
 DATE/TIME = 27-SEP-2012 10:05
 USER = jturley

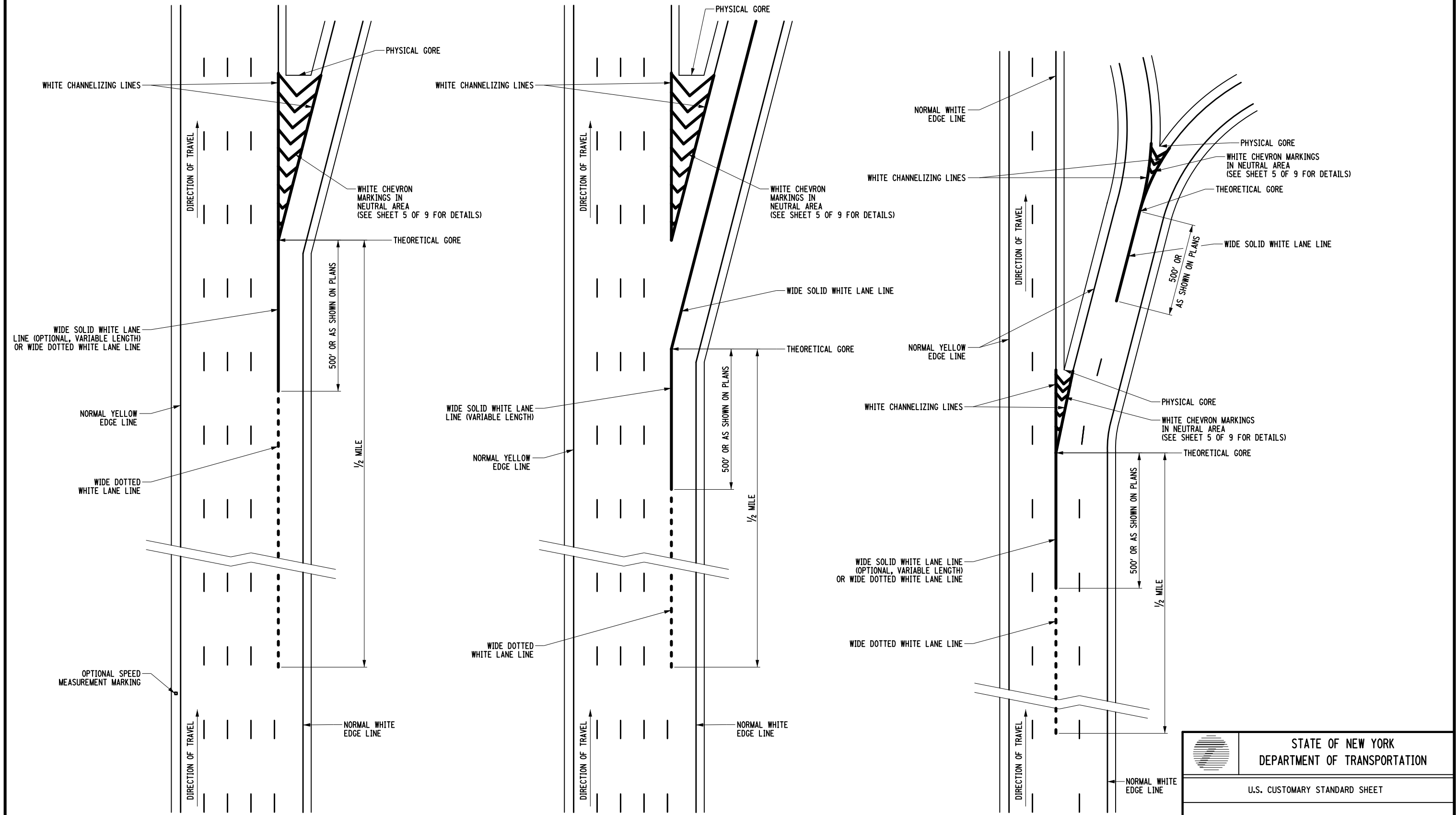

LANE DROP AT A SINGLE LANE EXIT RAMP

LANE DROP AT A MULTI-LANE EXIT RAMP WITH OPTION LANE

TWO-LANE DROP AT AN EXIT RAMP

	STATE OF NEW YORK DEPARTMENT OF TRANSPORTATION
	U.S. CUSTOMARY STANDARD SHEET
PAVEMENT MARKING DETAILS (SHEET 3 OF 9)	
APPROVED SEPTEMBER 24, 2012 /S/ TODD B. WESTHUIS, P.E. ACTING DIRECTOR, OFFICE OF TRAFFIC SAFETY AND MOBILITY	ISSUED UNDER EB 12-036 685-01

EFFECTIVE DATE: 05/02/2013

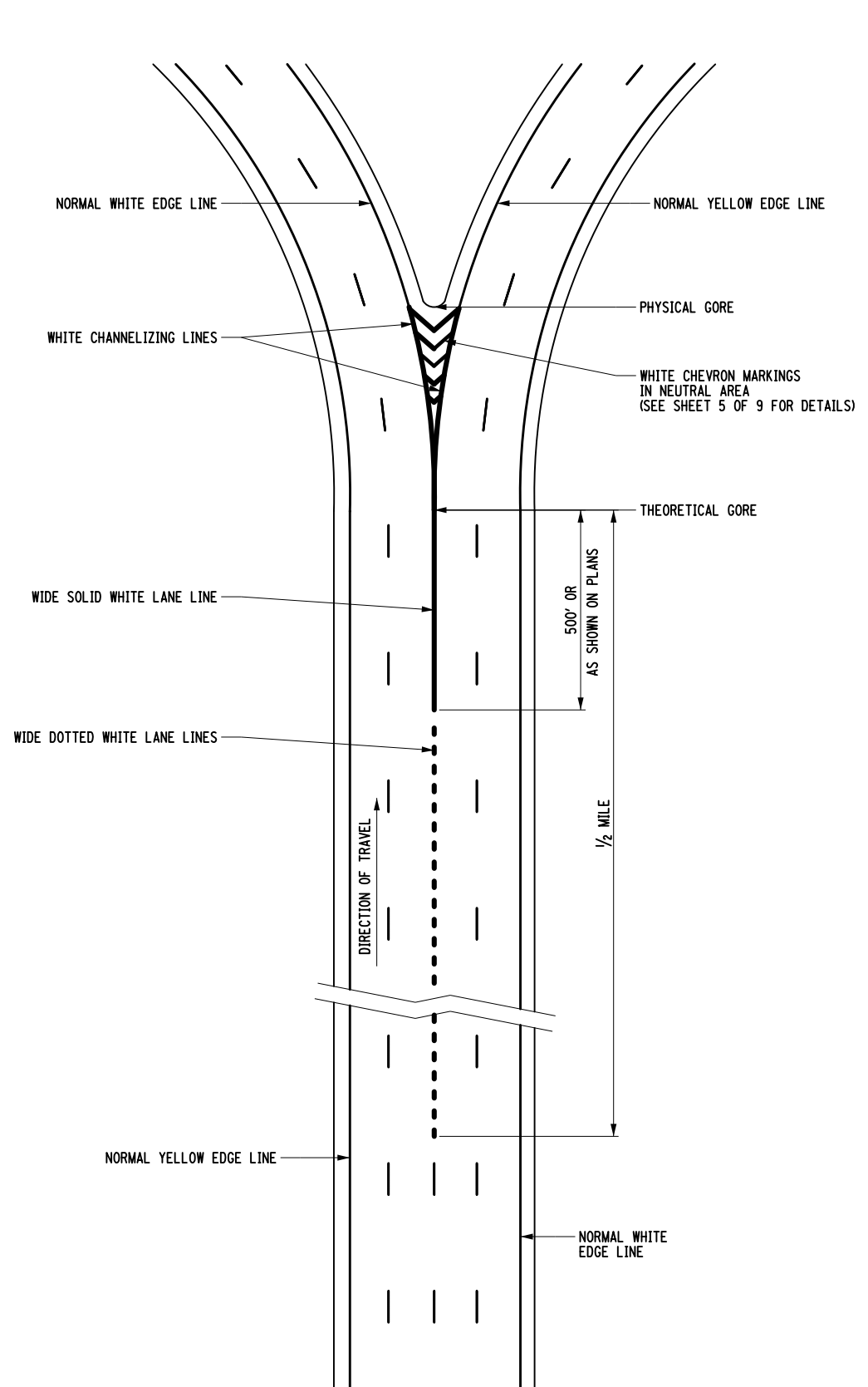

ROUTE SPLIT WITH DEDICATED LANES

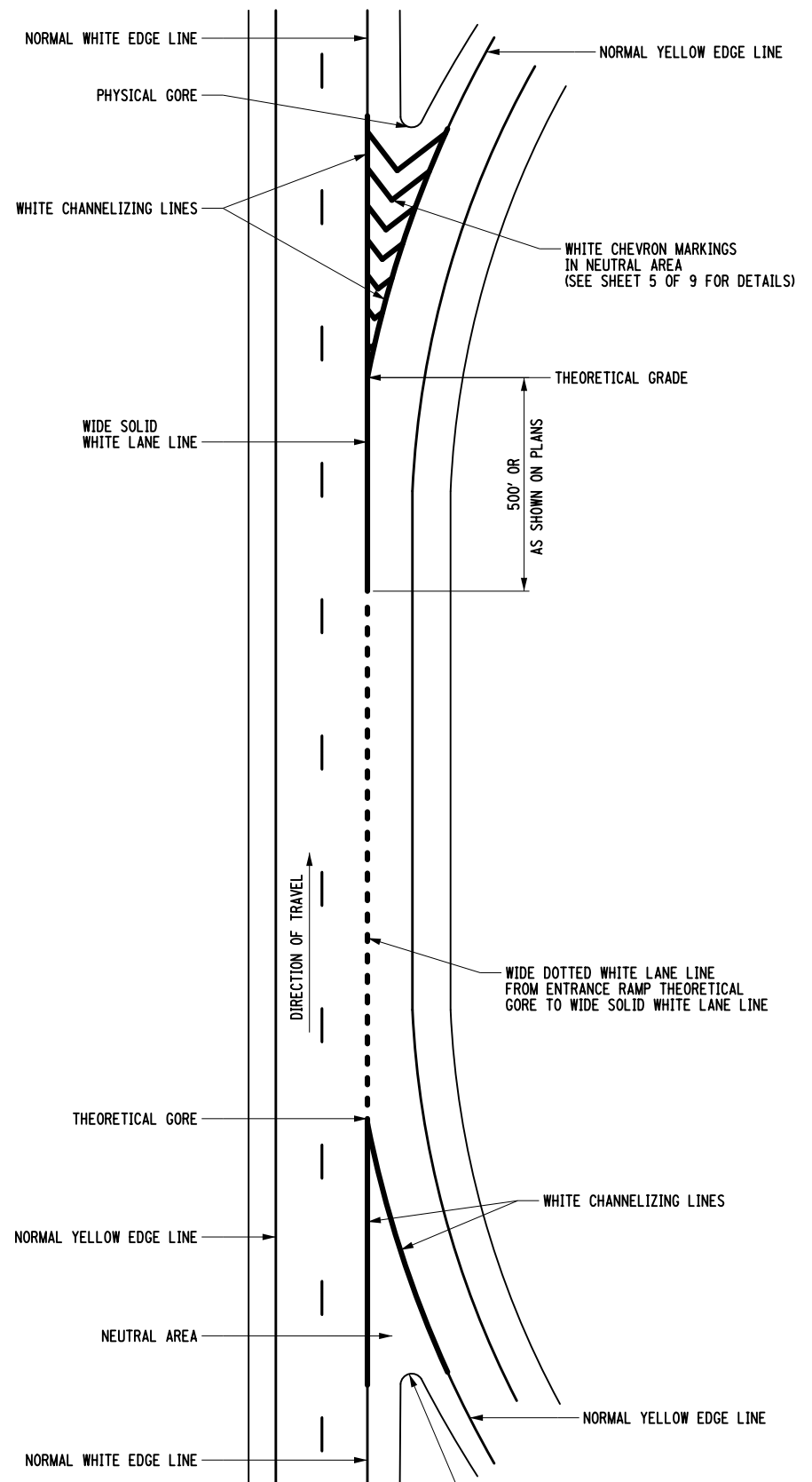

AUXILIARY LANE AT CLOSELY SPACED RAMPS

NOTE: USE THIS DETAIL WHERE DISTANCE FROM THEORETICAL GORE OF ENTRANCE RAMP TO THEORETICAL GORE OF EXIT RAMP IS LESS THAN OR EQUAL TO 3/4 MILE.

	STATE OF NEW YORK DEPARTMENT OF TRANSPORTATION	
	U.S. CUSTOMARY STANDARD SHEET	
PAVEMENT MARKING DETAILS (SHEET 4 OF 9)		
APPROVED SEPTEMBER 24, 2012	ISSUED UNDER EB 12-036	
/S/ TODD B. WESTHUIS, P.E. ACTING DIRECTOR, OFFICE OF TRAFFIC SAFETY AND MOBILITY	685-01	

EFFECTIVE DATE: 05/02/2013

FILE NAME = 685-0104_050213.dgn
 DATE/TIME = 27-SEP-2012 10:05
 USER = jturley

FILE NAME = 685-0105_050213.dgn
 DATE/TIME = 27-SEP-2012 10:05
 USER = jturley

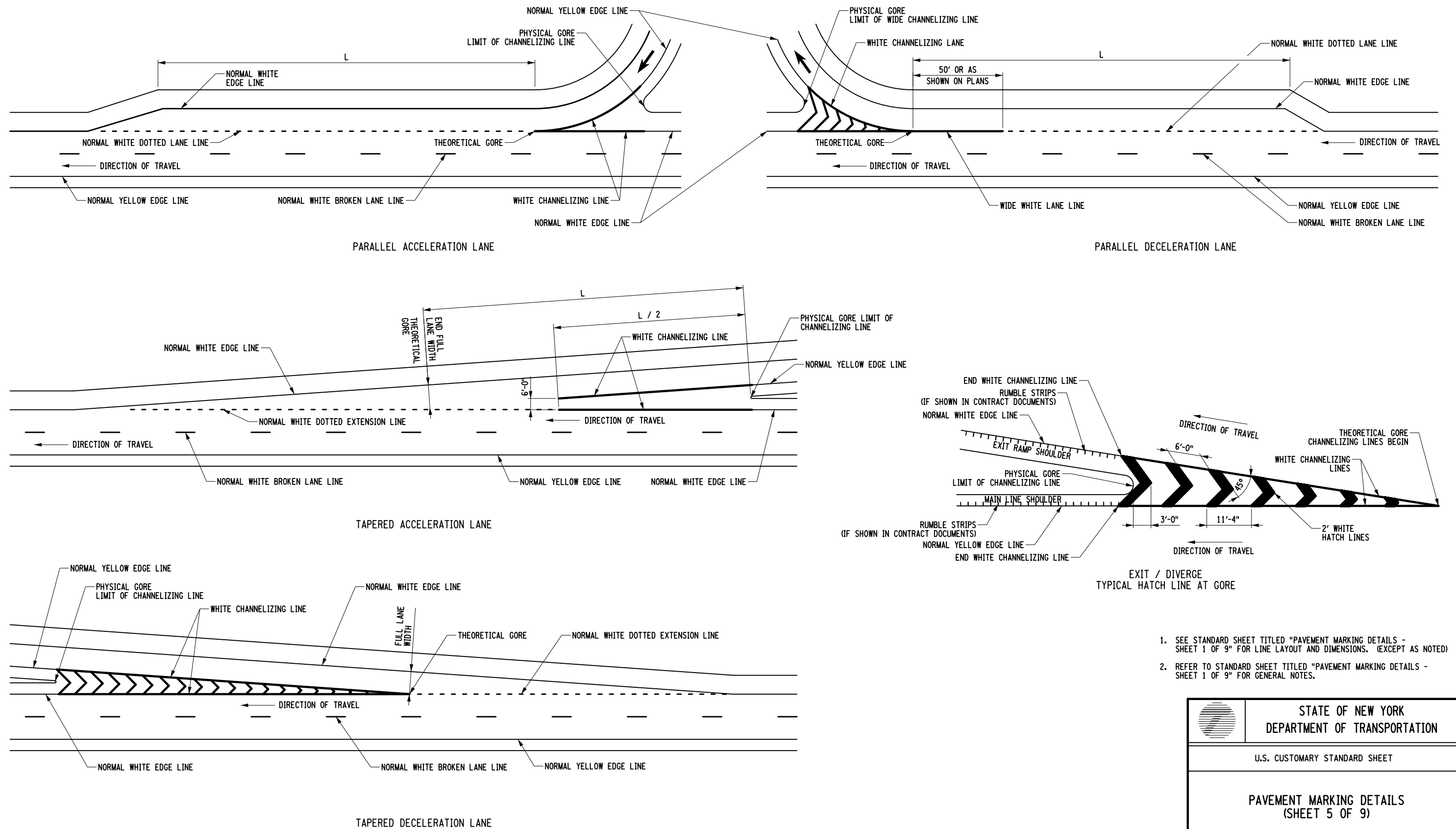

1. SEE STANDARD SHEET TITLED "PAVEMENT MARKING DETAILS - SHEET 1 OF 9" FOR LINE LAYOUT AND DIMENSIONS. (EXCEPT AS NOTED)
2. REFER TO STANDARD SHEET TITLED "PAVEMENT MARKING DETAILS - SHEET 1 OF 9" FOR GENERAL NOTES.

	STATE OF NEW YORK DEPARTMENT OF TRANSPORTATION
	U.S. CUSTOMARY STANDARD SHEET
PAVEMENT MARKING DETAILS (SHEET 5 OF 9)	
APPROVED SEPTEMBER 24, 2012 /S/ TODD B. WESTHUIS, P.E. ACTING DIRECTOR, OFFICE OF TRAFFIC SAFETY AND MOBILITY	ISSUED UNDER EB 12-036 685-01

EFFECTIVE DATE: 05/02/2013

FILE NAME = 685-0106_050213e1.dgn
 DATE/TIME = 14-NOV-2013 09:01
 USER = rlohse

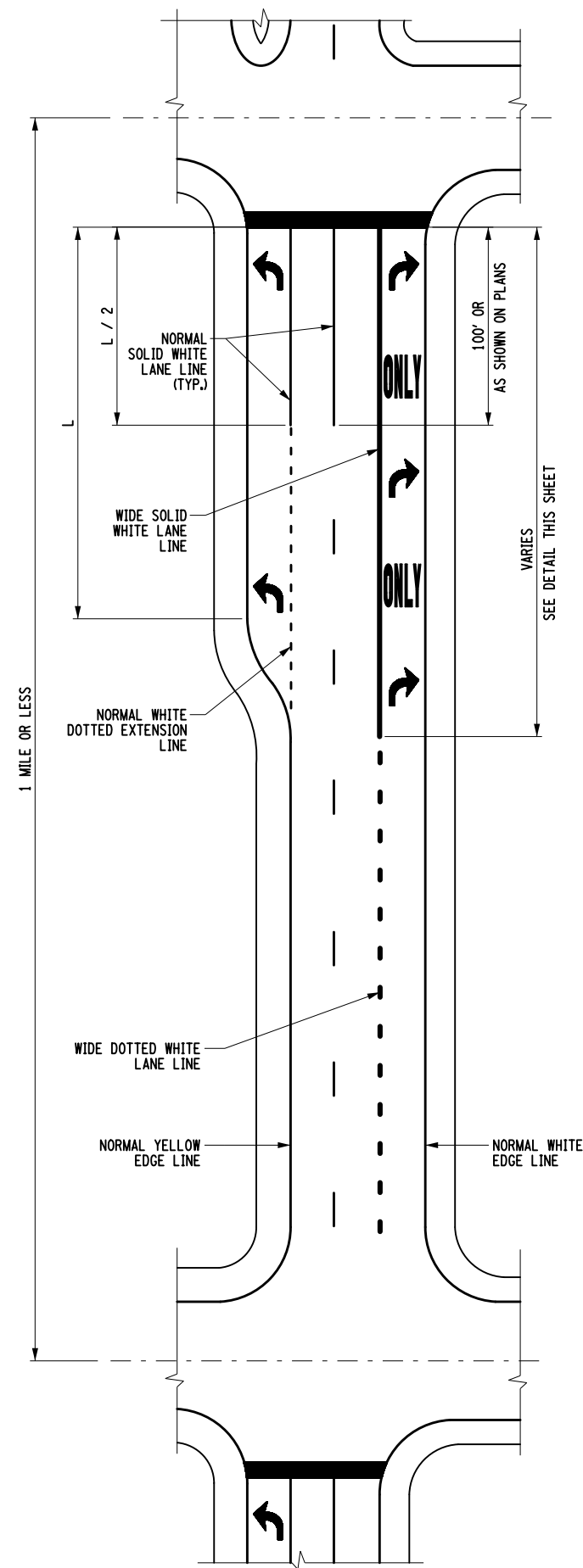

AUXILIARY LANE BETWEEN INTERSECTIONS
 LESS THAN OR EQUAL TO 1 MILE APART

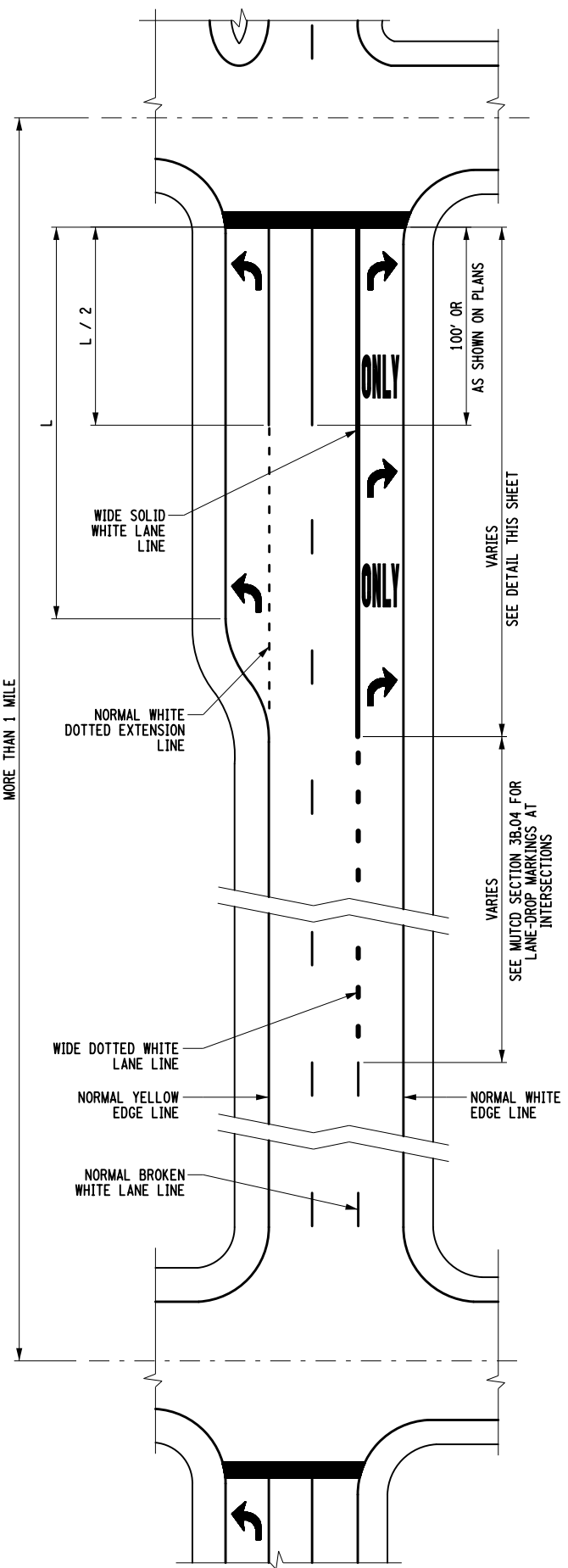

AUXILIARY LANE BETWEEN INTERSECTIONS
 GREATER THAN 1 MILE APART

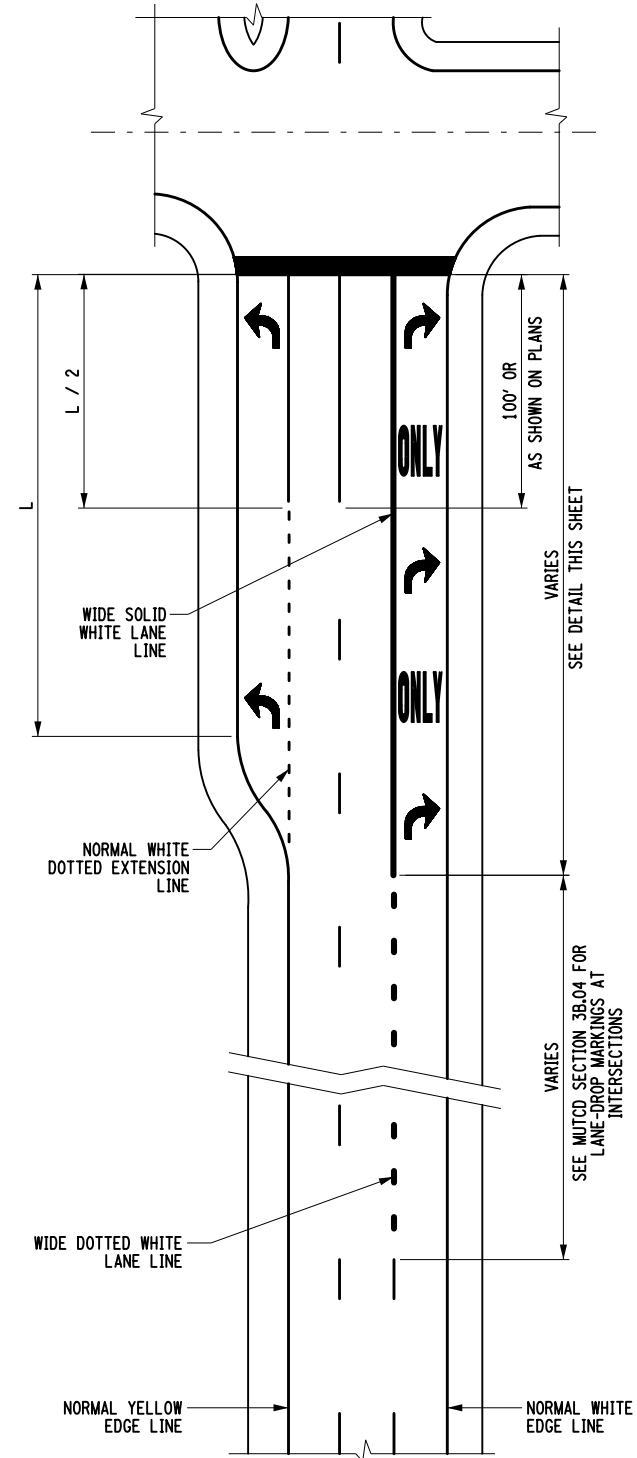

LANE DROP AT INTERSECTION

SYMBOL SPACING NOTES:

- S1. SPACING BETWEEN ARROWS AND "ONLY" (X) IS 32' MIN. AND 80' MAX. LOWER SPEED ROADS SHOULD HAVE CLOSER SPACING THAN HIGHER SPEED ROADS.
- S2. IF $L < 75'$ OR $L > 400'$, REFER TO CONTRACT DOCUMENTS OR REGIONAL TRAFFIC SAFETY AND MOBILITY GROUP FOR GUIDANCE ON SPACING OF ARROWS AND "ONLY".
- S3. ON AN UNCONTROLLED APPROACH (NO STOP SIGN, YIELD SIGN, OR TRAFFIC SIGNAL) OMIT STOP LINE.
- S4. IF INTERSECTION LANE CONTROL SIGNS (EG. R3-5) ARE NOT PROVIDED FOR THE LANE, THE "ONLY" MARKINGS SHALL BE DELETED.
- S5. ARROWS AND "ONLY" TO BE CENTERED IN THE LANE.

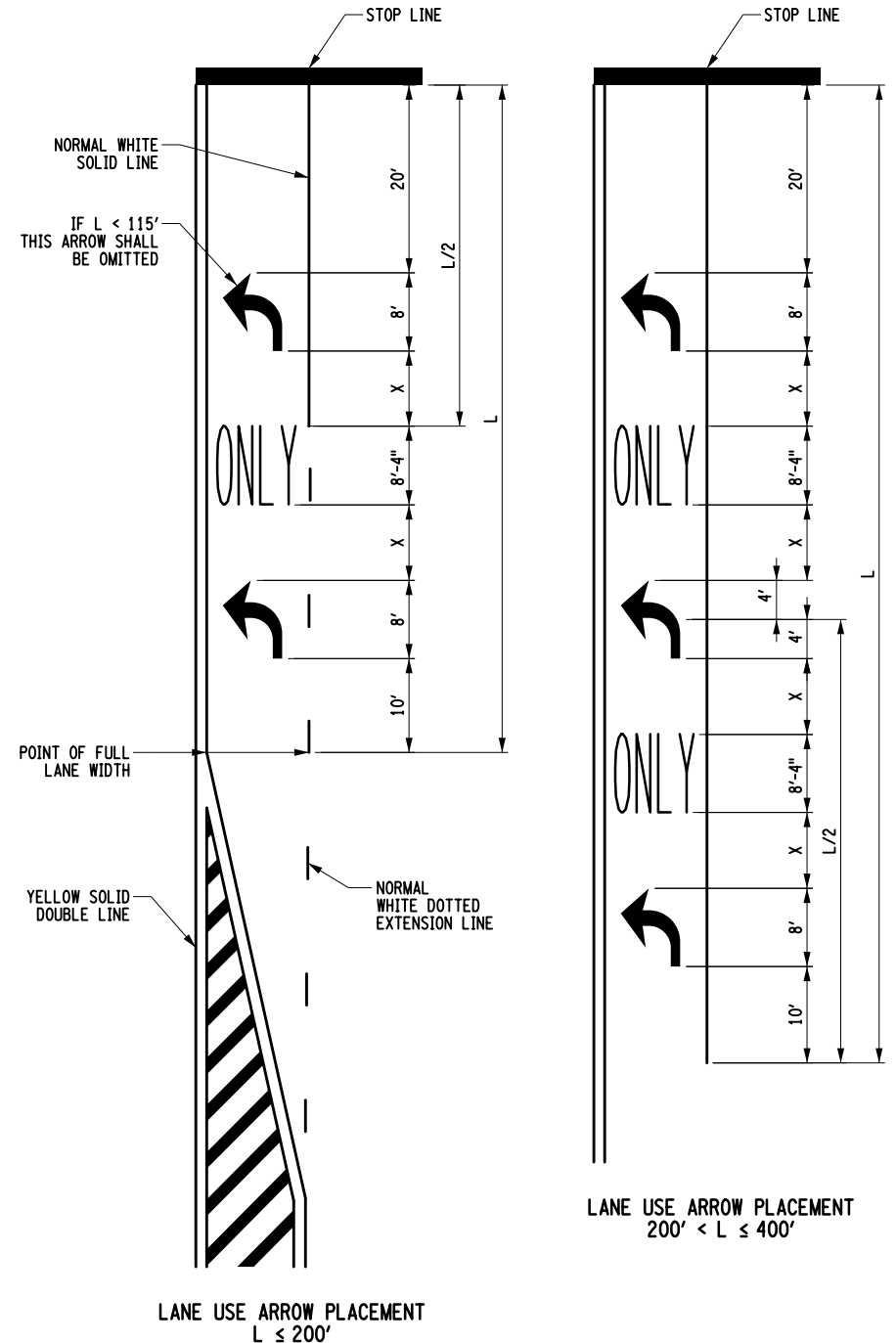

LANE USE ARROW PLACEMENT
 $L \leq 200'$

LANE USE ARROW PLACEMENT
 $200' < L \leq 400'$

	STATE OF NEW YORK DEPARTMENT OF TRANSPORTATION	
	U.S. CUSTOMARY STANDARD SHEET	
PAVEMENT MARKING DETAILS (SHEET 6 OF 9)		
APPROVED: OCTOBER 23, 2013 /S/ TODD B. WESTHUIS, P.E. DEPUTY CHIEF ENGINEER, TRAFFIC, SAFETY AND MOBILITY (ACTING)	ERRATA 1 EFF. 01/09/2014 ISSUED WITH EB 13-042 EFFECTIVE DATE: 05/02/2013	ISSUED UNDER EB 12-036 685-01

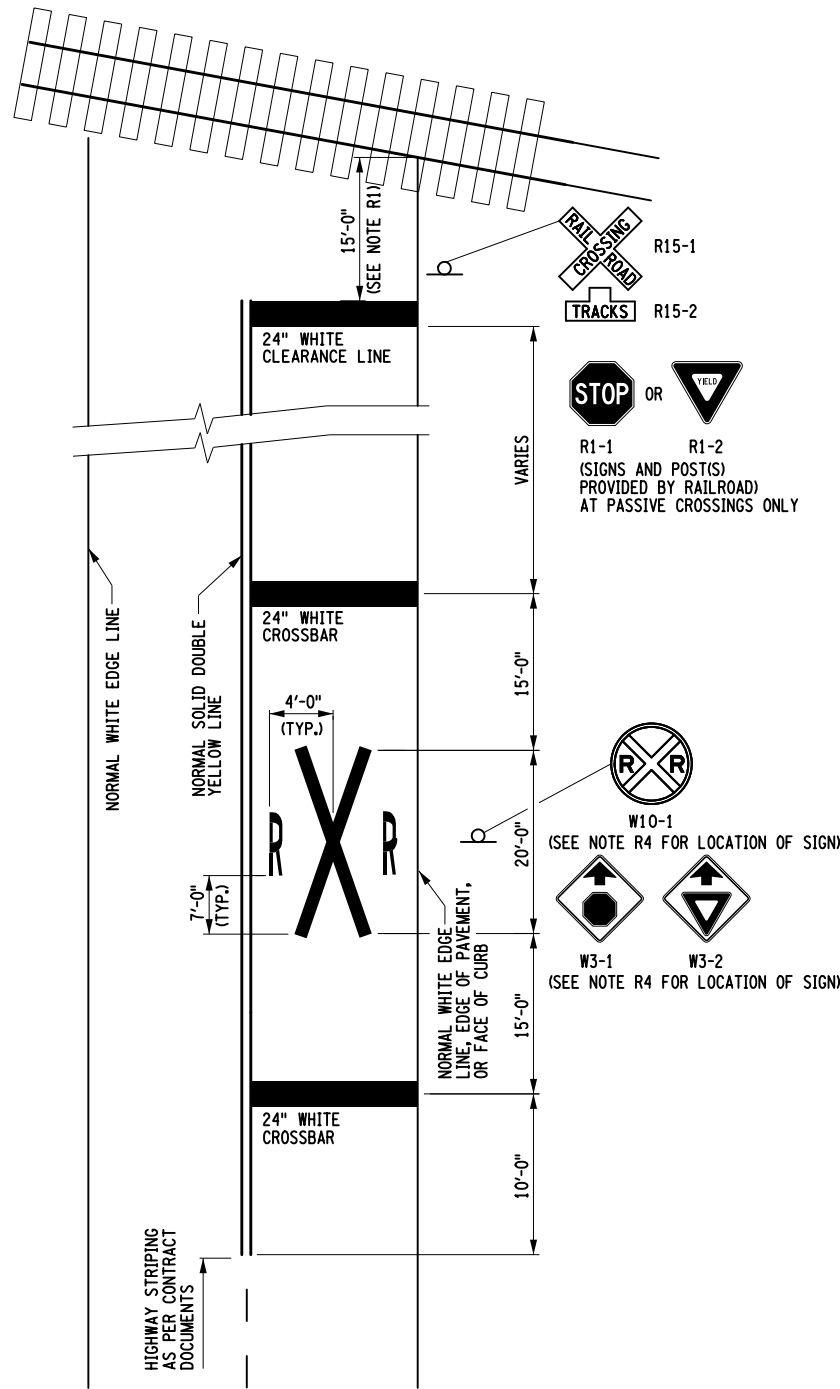

RAILROAD GRADE CROSSING MARKINGS AND LAYOUT PLAN

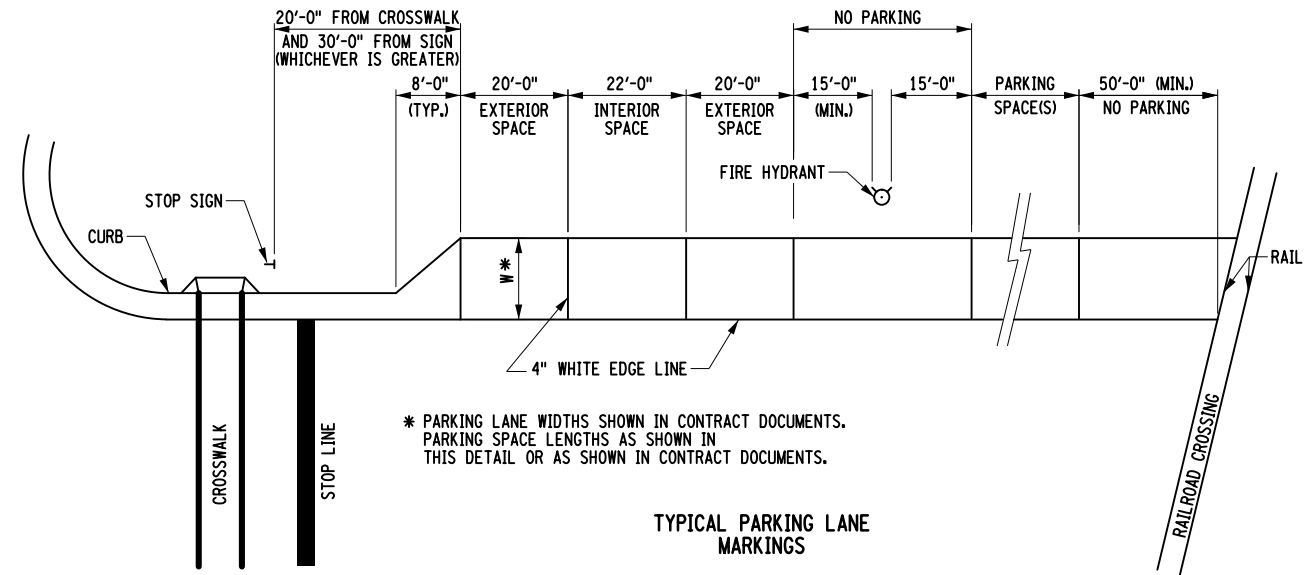

* PARKING LANE WIDTHS SHOWN IN CONTRACT DOCUMENTS.
PARKING SPACE LENGTHS AS SHOWN IN THIS DETAIL OR AS SHOWN IN CONTRACT DOCUMENTS.

TYPICAL PARKING LANE MARKINGS

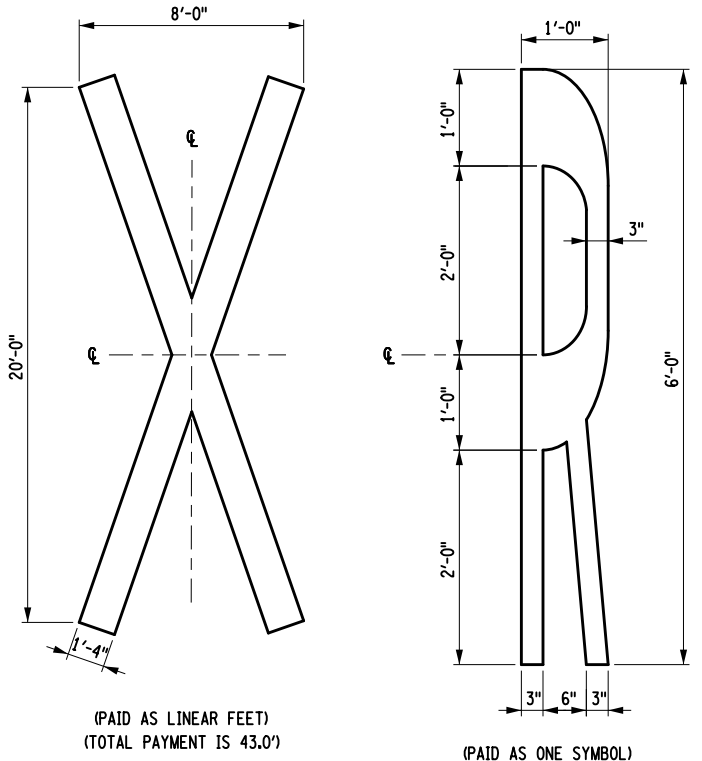

(PAID AS LINEAR FEET)
(TOTAL PAYMENT IS 43.0')

(PAID AS ONE SYMBOL)

RAILROAD GRADE CROSSING

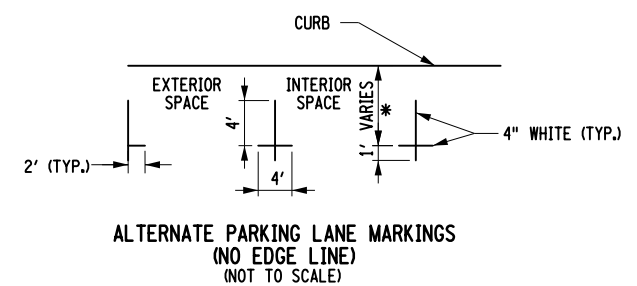

ALTERNATE PARKING LANE MARKINGS
(NO EDGE LINE)
(NOT TO SCALE)

RAILROAD GRADE CROSSING NOTES:

- R1. WHERE THERE IS NO RAILROAD CROSSING GATE, THE CLEARANCE LINE SHOULD BE PERPENDICULAR TO THE ROADWAY, AND 15'-0" FROM THE NEAREST RAIL AT ITS CLOSEST POINT. WHERE THERE IS A GATE, THE CLEARANCE LINE SHOULD BE PARALLEL TO THE GATE IN ITS LOWERED POSITION, AND EITHER 15'-0" FROM THE NEAREST RAIL OR 8'-0" FROM THE GATE, WHICHEVER PLACES THE LINE FURTHER FROM THE CROSSING.
- R2. ON A MULTI-LANE APPROACH, THE CLEARANCE LINE AND CROSSBARS SHALL EXTEND ACROSS ALL LANES, AND A "RXR" SYMBOL SHALL BE PLACED IN EACH LANE.
- R3. REFER TO STANDARD SHEET TITLED "PAVEMENT MARKING DETAILS - SHEET 1 OF 9" FOR GENERAL NOTES.
- R4. IF A W3-1 OR W3-2 SIGN IS NOT REQUIRED IN ADVANCE OF THE GRADE CROSSING, THE W10-1 SHALL BE LOCATED IN ACCORDANCE WITH TABLE NY2C-4. IF A W3-1 OR W3-2 SIGN IS REQUIRED IN ADVANCE OF A GRADE CROSSING, IT SHALL BE LOCATED IN ACCORDANCE WITH TABLE NY2C-4 AND THE W10-1 SIGN SHALL BE LOCATED APPROXIMATELY 200'-0" IN ADVANCE OF THE W3-1 OR W3-2 SIGN.
- R5. A PORTION OF THE "RXR" MARKING MUST BE OPPOSITE THE W10-1 SIGN. 24" WHITE CROSSBARS ARE PLACED IN RELATION TO "RXR" MARKING. THE DISTANCE TO CLEARANCE LINE WILL VARY.
- R6. NORMAL SOLID DOUBLE YELLOW LINE TO BEGIN A MINIMUM OF 10'-0" UPSTREAM OF FIRST 24" WHITE CROSS BAR.

FILE NAME = 685-0107.DTF.dgn
DATE/TIME = 04-OCT-2017 12:01
USER = rfoote



U.S. CUSTOMARY STANDARD SHEET

PAVEMENT MARKING DETAILS
(SHEET 7 OF 9)

ERRATA 1 ISSUED WITH EB 17-041	APPROVED SEPTEMBER 24, 2012 /S/ TODD B. WESTHUIS, P.E. ACTING DIRECTOR, OFFICE OF TRAFFIC SAFETY AND MOBILITY	ISSUED UNDER EB 12-036 685-01
EFFECTIVE DATE: 05/02/2013		

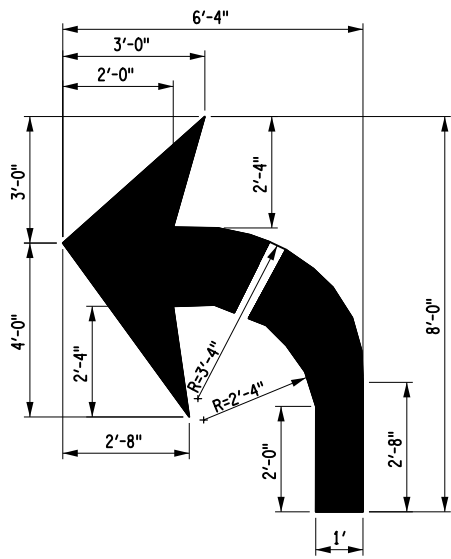

TURNING ARROW
(PAID AS ONE SYMBOL)

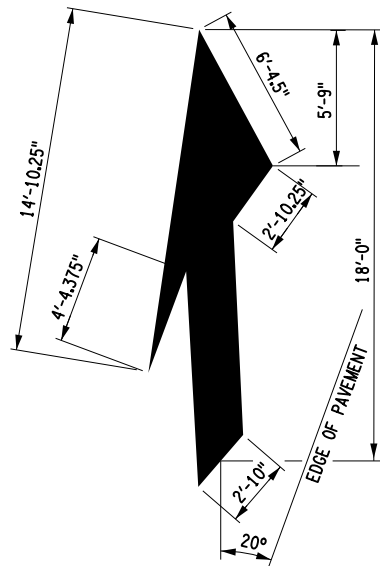

LANE REDUCTION ARROW
(PAID AS ONE SYMBOL)

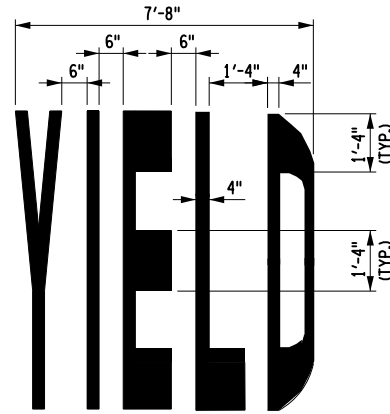

"YIELD" LETTERS
SEE NOTE
(PAID AS FIVE LETTERS)

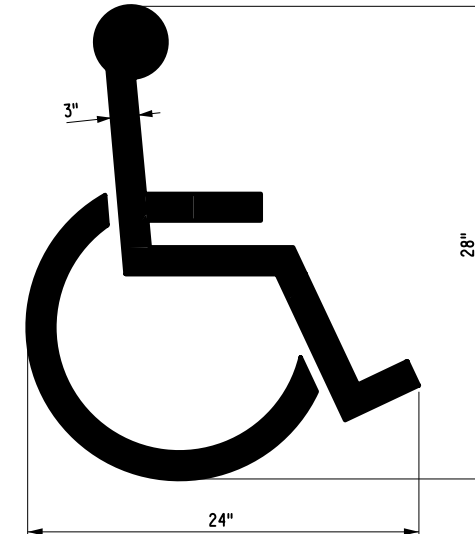

HANDICAPPED PARKING SYMBOL
(PAID AS ONE SYMBOL)

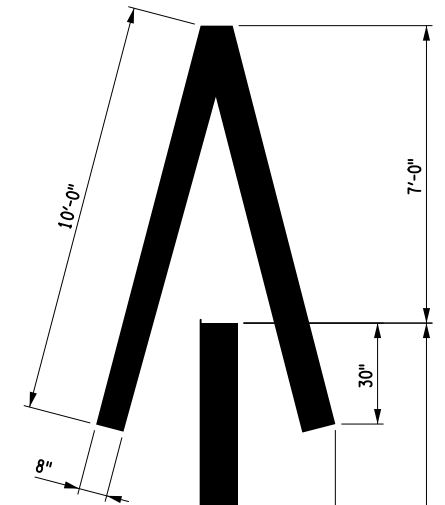

RAMP ARROW
(PAID BY LINEAR FEET)
(TOTAL PAYMENT IS 73')

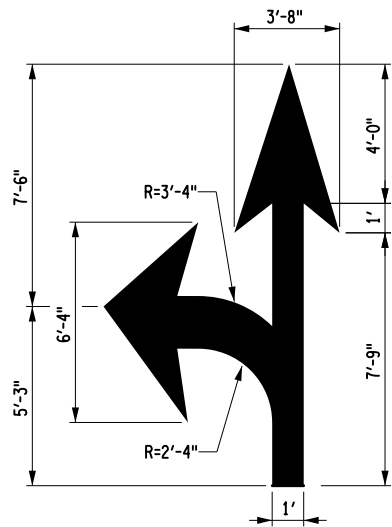

**TURNING/STRAIGHT ARROW
FOR SHARED LANE**
(PAID AS ONE SYMBOL)

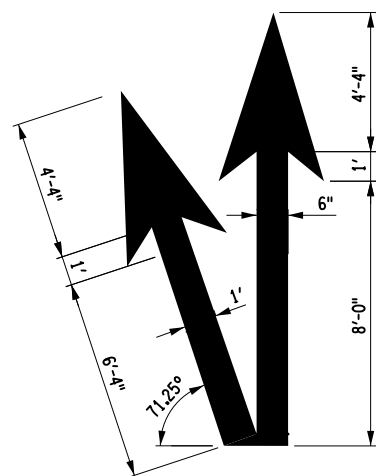

DIVERGE ARROW
(PAID AS ONE SYMBOL)

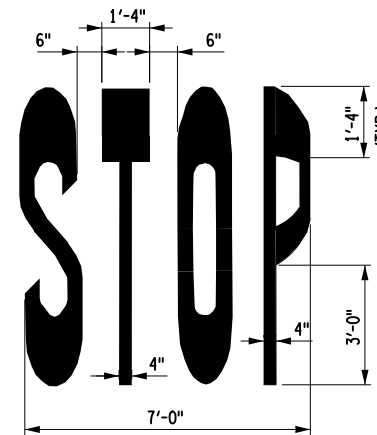

"STOP" LETTERS
SEE NOTE
(PAID AS FOUR LETTERS)

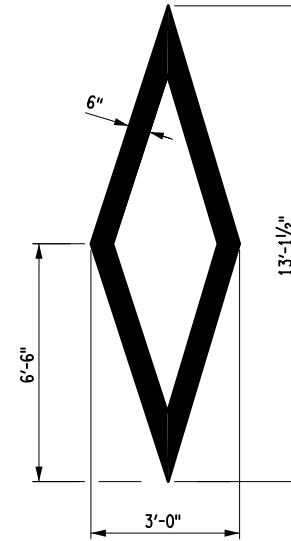

PREFERENTIAL LANE SYMBOL
(PAID BY LINEAR FEET)
(TOTAL PAYMENT IS 35')

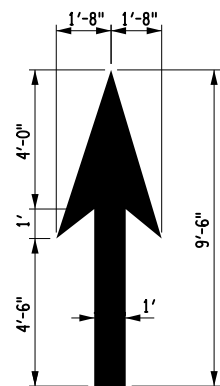

STRAIGHT ARROW
(PAID AS ONE SYMBOL)

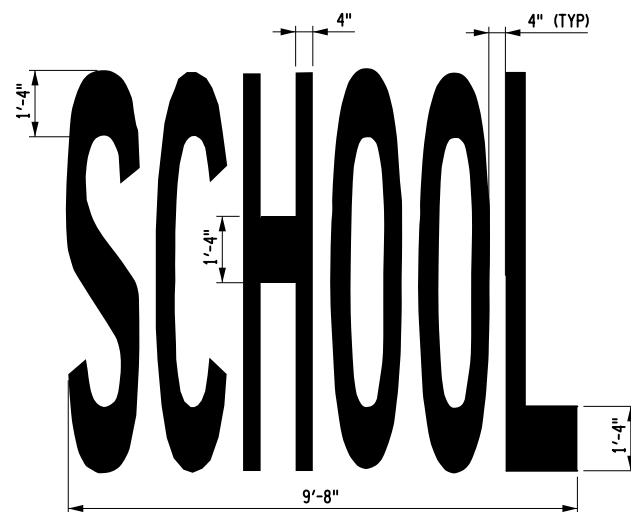

"SCHOOL" LETTERS
SEE NOTE
(PAID AS SIX LETTERS)

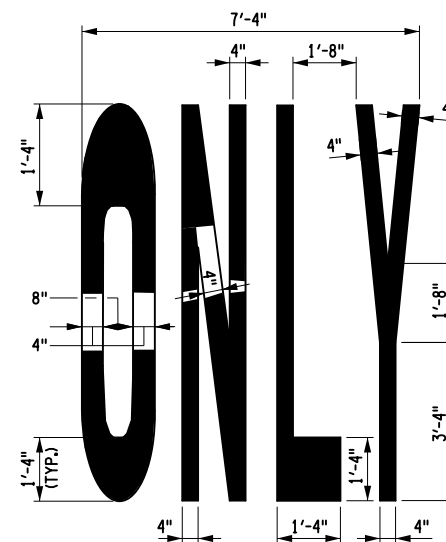

"ONLY" LETTERS
SEE NOTE
(PAID AS FOUR LETTERS)

NOTES:

UNLESS OTHERWISE SHOWN:
LETTER HEIGHT = 8'-4"
LETTER WIDTH = 1'-4"
SPACING = 8"
(USE EQUAL SPACING BETWEEN LETTERS AND CENTER ENTIRE SYMBOL IN LANE)

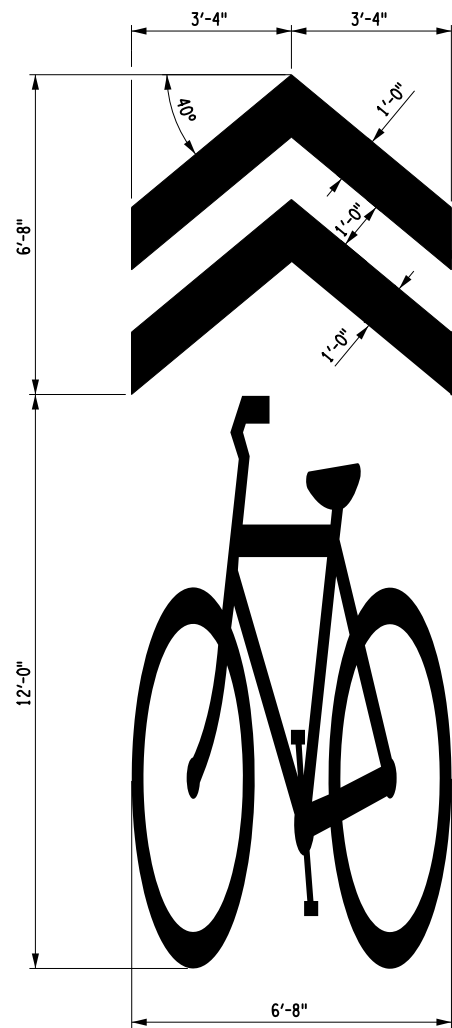

SHARED LANE USE MARKING DETAIL
(CHEVRON PAID BY LINEAR FEET)
(BICYCLE PAID AS ONE SYMBOL)

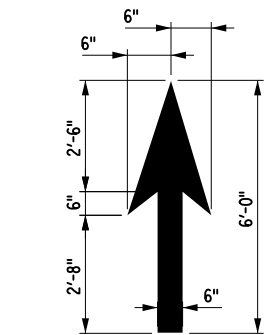

BICYCLE ARROW
(PAID AS ONE SYMBOL)

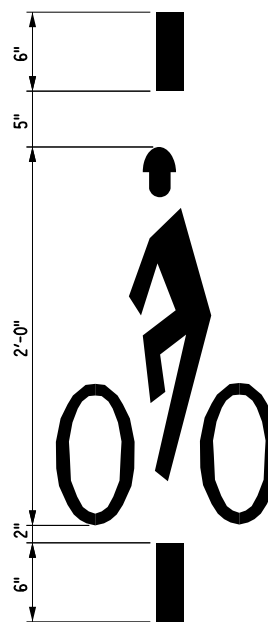

BICYCLE DETECTOR MARKER
(PAID AS ONE SYMBOL)

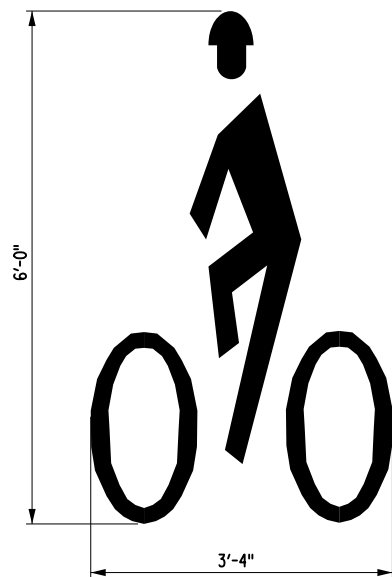

BICYCLE SYMBOL
(PAID AS ONE SYMBOL)

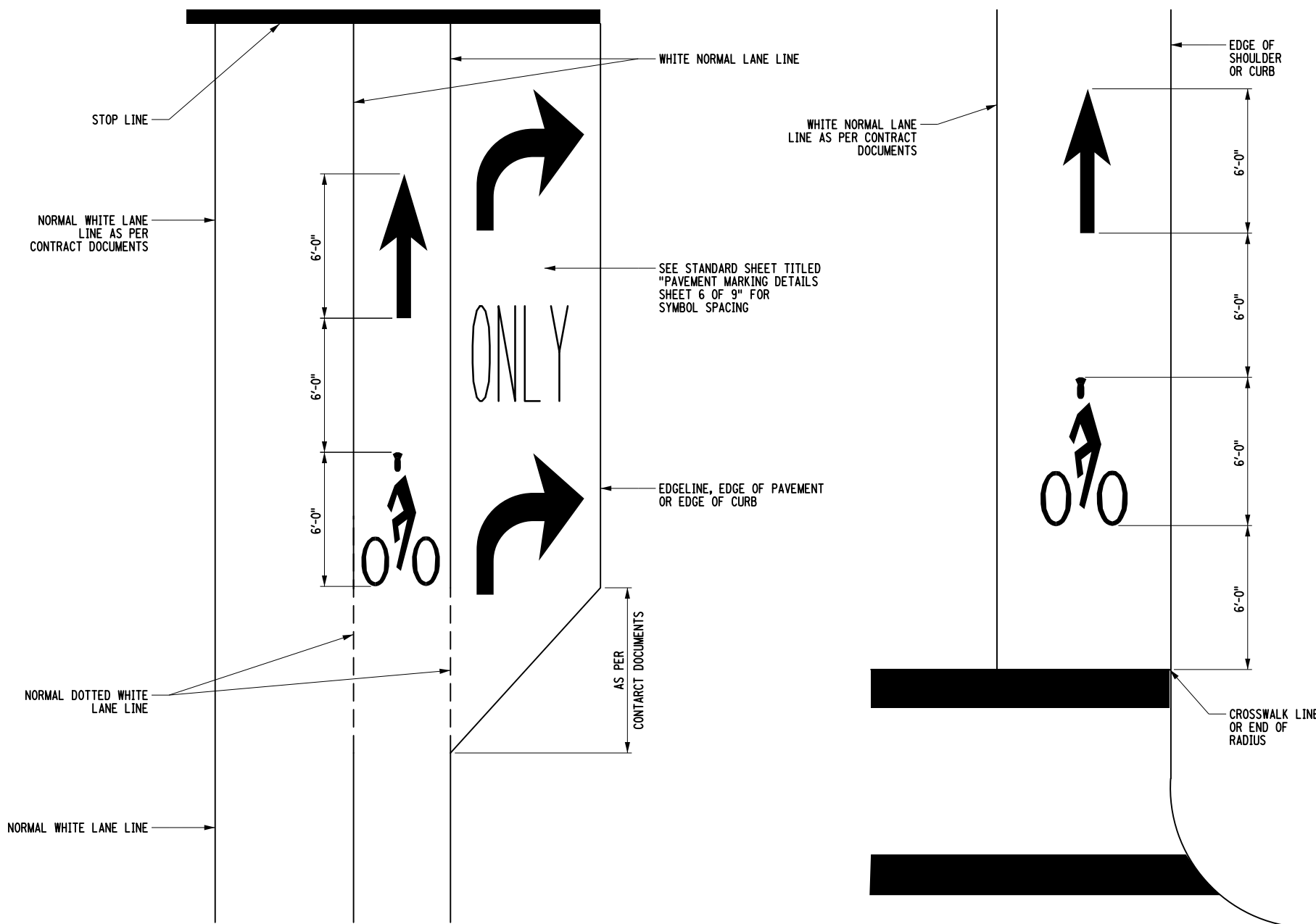

**BICYCLE LANE MARKING
ADJACENT TO RIGHT TURN LANE**

BICYCLE LANE MARKING

BICYCLE LANE MARKING NOTES:

- B1. CENTER SYMBOL IN BICYCLE LANE OR SHOULDER.
- B2. PLACE BICYCLE LANE ARROW AND SYMBOL DOWNSTREAM OF MAJOR OR SIGNALIZED INTERSECTIONS.
 - PLACE BICYCLE SYMBOL AT 1320'-0" SPACING ALONG BICYCLE LANE OR AS INDICATED IN THE CONTRACT DOCUMENTS.
 - PLACE BICYCLE LANE ARROW AND SYMBOL 200'-0" UPSTREAM OF MAJOR OR SIGNALIZED INTERSECTIONS.
- B3. MARKINGS AS PER THE DIRECTIONS OF THE REGIONAL OFFICE OF TRAFFIC SAFETY AND MOBILITY GROUP OR AS PER PLAN. SIGNS SHALL BE USED WITH THE BICYCLE LANE.

ERRATA 1
ISSUED WITH EB 17-041
EFFECTIVE DATE: 05/02/2013

NEW YORK STATE OF OPPORTUNITY.		Department of Transportation
U.S. CUSTOMARY STANDARD SHEET		
PAVEMENT MARKING DETAILS (SHEET 9 OF 9)		
APPROVED SEPTEMBER 24, 2012	/S/ TODD B. WESTHUIS, P.E.	ISSUED UNDER EB 12-036
ACTING DIRECTOR, OFFICE OF TRAFFIC SAFETY AND MOBILITY		685-01