

*Where Tradition and
Innovation Meet*



Conventional Travel
Trailer & Fifth-Wheel
Travel Trailer

Owner's Manual

Cunningham Campers, Inc.

5201 Highway 62
Jeffersonville, IN 47130

1-812-284-0276 Option 3



Welcome to our Used Jayco Owners' Group

We Know Jayco Parts!

As a group member you receive **10% OFF** any order for parts, not already on sale. Just call us **with your VIN #** and we will find what you need and ship it directly from Jayco to your front door.

Like Jayco, we are family owned and operated. Our courteous professionals are here to help make your shopping experience as pleasant as humanly possible.

1-812-284-0276

Use Option 3 For Parts

<http://parts.cunninghamcampers.com/jaycoclub>

Cunningham's – Selling & Servicing Jayco RV's for OVER 38 Years!

This manual has been provided by Jayco, Inc. for the sole purpose of providing instructions concerning the operation and maintenance of this vehicle and its components. Nothing in this manual creates any warranty, either expressed or implied. The only warranty offered by Jayco, Inc. is as set forth in the limited warranty applicable to this vehicle.

The owner's failure to provide required service and/or maintenance could result in the loss of warranty. The owner should review Jayco's limited warranty and the limited warranties of all other manufacturers offering them that are applicable to this vehicle.

Instructions are included in the manual for operating various components which are optional on some vehicles. In addition, the owner should refer to individual manufacturer's operating instructions contained in the owner's packet.

WARNING: READ YOUR OWNER'S MANUAL AND ALL SAFETY INSTRUCTIONS AND WARNINGS BEFORE USING OR OPERATING YOUR VEHICLE, TO REDUCE THE RISK OF PERSONAL INJURY OR PROPERTY DAMAGE.

WARNING: TOWING YOUR TRAILER WITH AN INADEQUATE TOW VEHICLE OR HITCH ASSEMBLY MAY LEAD TO EXCESSIVE SWAYING OR OTHER LOSS OF CONTROL, WITH PERSONAL INJURY OR PROPERTY DAMAGE RESULTING FROM ROLLOVER OR COLLISION. Make sure to read and understand Chapter 3 on using your recreational vehicle.

YOUR NEW JAYCO IS YOUR PASSPORT TO A WHOLE WORLD OF NEW FRIENDS,
CAMPING FUN AND TRAVEL ADVENTURE WHEN YOU JOIN THE THOUSANDS OF
JAYCO FAMILIES WHO MAKE UP THE . . .

JAYCO JAFARI INTERNATIONAL TRAVEL CLUB

You will find us enjoying the friendship and fellowship of JAFARI CAMPING as we join our
local area FLIGHTS at hundreds of weekend camp-outs all over North America each month . . .

WE'RE THE FAMILIES OF JAYCO!

There are special STATE, REGIONAL and INTERNATIONAL RALLIES where you can join
with your fellow JAFARIANS and their flights to enjoy a special kind of togetherness . . . fun,
games, and entertainment provide memories to last a lifetime.

And . . . how about the exotic surroundings of NEW ORLEANS, the sounds and color of
NASHVILLE and the GRAND OLE OPRY, the roar and rush of the INDIANAPOLIS 500, the
quiet surroundings of the CANADIAN ROCKIES, the color of the SMOKY MOUNTAINS in
the Fall. These and many other adventures can be yours when you join the. . .

JAYCO JAFARI INTERNATIONAL TRAVEL CLUB

Fill in the blanks on the reverse side, cut along dotted line and mail along with a check to:

JAYCO JAFARI INT'L TRAVEL CLUB

ATTN: Membership Coordinator

P.O. Box 192

Osceola, IN 46561-0192

Yes, it's for everyone with a JAYCO RV; young couples just starting out, families spending quality time together, the young at heart expanding their life experiences. Whether you belong to another camping club, have always traveled alone, or are just starting, don't miss out on one of the most priceless benefits of being an RV family . . . meet new friends and spend a bit of your camping life with some of the finest people you will ever have the opportunity to share a campfire or treasure a moment of golden living with a . . . FIFTH-WHEEL TRAVEL TRAILER. . .SPORT UTILITY TRAILER . . . CONVENTIONAL TRAVEL TRAILER . . . TYPE C MOTORHOME . . . FOLDING CAMPING TRAILER . . . it doesn't matter. If you are a JAYCO RV FAMILY, then you are eligible to become a Jayco Jafari Member.

YOU WILL NEVER BE SORRY YOU MADE THE DECISION!

Your membership entitles you to:

- Special international decals for your unit.
- The Hitch newsletter with schedules of upcoming events and activities.
- A membership roster - containing the names and addresses of current members of the club will be sent bi-yearly.
- Discount Cards for several national theme parks including Six Flags and Busch Corp. Parks.
- A special price is available on Wheeler's Campground Guides.
- Discounts with Hertz Rental Car.
- Discounts with Coach Net, an emergency roadside service.
- Farm & City Insurance has RV insurance available at discounted rates to current Jayco Jafari International Club members.
- All of this, plus the joy of meeting new friends and enjoy Jafari adventures around the country.

Start with the first phase of your camping life...just complete the following application and forward it to the Jayco Jafari International Travel Club office. Your membership application may also be completed online, by visiting our website at www.jaycorvclub.com. If you have further questions. contact the club office direct at the website or by calling 800-262-5178. Local calls can be made to 574-258-0571.



WELCOME TO THE JAFARI FAMILY!



 TO: Membership Coordinator for the Jayco Jafari International Travel Club

Please enroll us as members in the Jayco Travel Club. We are ready to roll to where the "friends we just haven't met yet" have the coffee on the fire and are waiting for us to arrive: We are ...

Name: _____ Spouse: _____

Address: _____ Phone: _____

City: _____ State: _____ Zip: _____

Email: _____

Ages of Children at Home: _____

Our JAYCO is a: _____ Our Dealer _____
 (type & size)

Membership Dues:

| | | | |
|--------------|---------|---------------------|-------|
| One year | \$25.00 | Amount enclosed. \$ | _____ |
| Two years: | \$45.00 | Check #: | _____ |
| Three years: | \$65.00 | | |

 (signature) (date)

Table of Contents

Chapter 1 – Introduction To RV Ownership

| | |
|--|---|
| Welcome | 1 |
| Safety Considerations | 2 |
| Reporting Safety Defects | 2 |
| Safety in Using LP Gas | 2 |
| Electrical System Safety | 3 |
| Safety When Emergency Stopping | 3 |
| Additional Safety Considerations | 3 |
| Insurance | 4 |
| Extended Use | 4 |
| Cold Weather Use | 4 |
| Condensation | 5 |

Chapter 2 – Obtaining Service

| | |
|--------------------------------|---|
| Warranty Registration | 6 |
| Service Procedures | 8 |
| Basic Service Procedures | 8 |
| Dealer | 8 |
| Factory | 9 |
| Parts | 9 |
| Owner’s Responsibility | 9 |

Chapter 3 – Using Your Travel Trailer

| | |
|---|----|
| Equipment | 10 |
| Tow Vehicle | 10 |
| Hitches – Conventional Travel Trailer | 11 |
| Hitch Height Specifications - Conventional Travel Trailer | 12 |
| The Hitching Procedure – Conventional Travel Trailer | 12 |
| The Safety Chain – Conventional Travel Trailers | 13 |
| Hitches – Fifth-Wheel Travel Trailer | 14 |
| Hitch Height - Fifth-Wheel Travel Trailer | 14 |
| The Hitching Procedure – Fifth-Wheel Travel Trailer | 14 |
| Towing | 14 |
| Traveling | 16 |
| Weights and Cargo Capacity | 16 |
| Loading Cargo | 18 |
| Weighing Instructions | 18 |
| Tires | 19 |
| Tire Chart | 19 |
| Vinyl Tire Covers (Option) | 20 |
| Wheel Lugs | 21 |
| Fire Extinguisher | 21 |

| | |
|---|----|
| Brakes | 21 |
| Electrical | 21 |
| Breakaway Switch | 22 |
| Slideout Room Option | 23 |
| Components | 23 |
| Operations (Manual Slideout – Resort Travel Trailers) | 23 |
| Operation (Manual Slideout – Qwest Travel Trailer) | 24 |
| Operations (Electric Slideout) | 25 |
| Troubleshooting Electric Slideout | 25 |
| Overriding the Electric Slideout System | 26 |
| Bedroom Slideout Override | 26 |
| Slideout Diagram | 27 |
| Setting Up Your Travel Trailer | 29 |
| Carbon Monoxide Detector (Option) | 30 |
| Fifth-Wheel Travel Trailers Only | 30 |
| Procedures to Take During an Alarm | 30 |
| Maintenance/Testing | 30 |
| TV Antenna | 31 |
| Raising Antenna to Operating Position | 31 |
| To Test System | 31 |
| Lowering Antenna to Travel Position | 31 |
| Maintenance | 31 |

Chapter 4 – The Systems

| | |
|---|----|
| Plumbing System | 32 |
| City Water Connection | 32 |
| Water Tank – Gravity Fill | 32 |
| 12 Volt DC Demand Pump | 33 |
| Sanitizing and Filling the Potable Water System | 33 |
| Definition of the Utility Center Label Terms | 34 |
| Sanitizing Units with Utility Center | 35 |
| Faucets | 37 |
| Bath and Shower | 37 |
| Outside Shower (Option) | 37 |
| Drainage | 37 |
| Sanitation System (Marine Toilets Only) | 39 |
| Toilets | 39 |
| Maintenance | 39 |
| Residential Stools (Resort Model Only) | 40 |
| Using Toilet and Tank System | 40 |
| Vents | 40 |
| Holding Tanks | 40 |
| Winterizing Travel Trailer | 42 |
| Winterizing Units with Utility Center | 43 |

| | |
|--|----|
| LP Fuel System | 44 |
| LP Container | 44 |
| Servicing and Filling LP Containers | 44 |
| OPD Overfill Protection | 46 |
| Main Supply Hose – Low Pressure | 47 |
| Regulator | 47 |
| Automatic Changeover Regulator | 48 |
| Operation | 48 |
| Checking for Leaks | 49 |
| If You Smell Gas | 49 |
| LP Gas Consumption | 49 |
| LP Detector | 50 |
| Operation | 50 |
| Testing | 50 |
| Alarm | 51 |
| Low Power Operation | 51 |
| Electrical System | 52 |
| General | 52 |
| Changes, Modifications and Additions | 52 |
| 120-Volt AC System | 52 |
| Power Cord | 52 |
| GFCI | 53 |
| 30-amp Service | 54 |
| 50-amp Service (Option) | 54 |
| Consumption of 120-volt AC Power | 55 |
| 12-Volt DC System | 55 |
| Converter | 55 |
| Auxiliary Battery (Option) | 55 |
| Battery Isolator (For Tow Vehicle) | 56 |
| Exterior Lights | 56 |
| Porch Light | 56 |
| Television Cable | 56 |
| Fluorescent Lighting (Option) | 57 |
| Fuse and Bulb Chart | 57 |
| Brakes | 58 |

Chapter 5 – Appliances

| | |
|---|----|
| General | 59 |
| Furnace | 59 |
| For Your Safety (Read Before Operating) | 60 |
| Operating Instructions | 60 |
| To Turn Off Gas to Appliance | 61 |
| Ducting and Return Air | 61 |
| Range and Oven Operation | 62 |

| | |
|--|----|
| Water Heater | 63 |
| Pilot Operation | 64 |
| Electric Ignition Operation | 65 |
| Pilot Re-ignite Operation | 65 |
| Electric Operation | 66 |
| Flushing Instructions | 66 |
| Refrigerator - RV Type | 67 |
| Leveling | 67 |
| Venting | 67 |
| Door Seal | 68 |
| Battery Drain | 68 |
| Controls | 68 |
| N621 and N841 Series Refrigerators | 69 |
| Door Handles | 69 |
| Interior Light | 69 |
| Door Alarm | 69 |
| Backup Operating System | 70 |
| Operating the Refrigerator Controls – N621 | 70 |
| Operating the Refrigerator Controls – N841 | 71 |
| Ice Maker | 73 |
| Refrigerator - Residential Units | 73 |
| Monitor Panel | 73 |
| BBQ Grill (Option) | 74 |

Chapter 6 – Care of Body Components

| | |
|--|----|
| Exterior Aluminum | 76 |
| Fiberglass Sidewalls | 76 |
| Exterior Roof | 76 |
| Stone Guard | 77 |
| ABS Plastics | 77 |
| Frame | 77 |
| Doors, Extrusions, Windows & Vents | 77 |
| Furniture | 77 |
| Cushions | 78 |
| Bedspreads | 78 |
| Window Treatments | 78 |
| Shower Curtain and Liner | 78 |
| Tire Covers - Vinyl (Optional) | 78 |
| Paneling | 79 |
| Vinyl Floor | 79 |
| Wood Floor | 79 |
| Bathroom Tubs, Lavatory Sinks | 79 |
| Carpeting | 79 |
| Countertops | 79 |
| Hardware and Sink or Shower Fixtures | 79 |

Chapter 7 – Maintenance/Storage

| | |
|---|----|
| Slideout | 80 |
| Carbon Monoxide Detector | 80 |
| Testing | 80 |
| Battery Replacement | 81 |
| Cleaning | 81 |
| Unit Replacement | 81 |
| TV Antenna | 81 |
| Furnace Maintenance | 82 |
| Toilets | 82 |
| Storage | 83 |
| LP Gas Bottles | 83 |
| Mechanical Maintenance Chart | 84 |
| Inspection Points for Sealing | 89 |
| Maintenance Checklist | 91 |

Chapter 8 – Options

| | |
|---|-----|
| Air Conditioner | 94 |
| Generator | 94 |
| Refueling Generator | 95 |
| Microwave Oven / Convection Oven | 96 |
| Rubber Roof | 96 |
| RV Digital Satellite System | 96 |
| Spare Tire Carrier | 96 |
| Ceiling Fan | 97 |
| Security Lights | 97 |
| Patio Door | 97 |
| Towable Transferable Limited Warranty | 98 |
| Limited Warranty Transfer Application | 100 |

NOTES

CHAPTER 1

INTRODUCTION TO RV OWNERSHIP

WELCOME

Thank you for purchasing your Jayco Recreation Vehicle and welcome to the world of recreation vehicle travel. Your purchase of a Jayco RV allows you to enter this unique world of camping and leisure in a grand style. **Your Jayco RV has been designed and engineered to offer you many comforts of home that will make your camping experience as enjoyable as possible. Jayco recreation vehicles are designed, constructed and intended to be used as temporary living quarters for recreation, camping and travel uses, all as defined in the bylaws of the Recreation Vehicle Industry Association. Our recreation vehicles are not intended for the hauling of cargo.**

This owner's manual was prepared to assist you in understanding the proper use and operation of various containment systems, servicing and maintenance of component parts, and explanation of your warranty protection. If you are a newcomer to RV travel, you will especially appreciate the suggestions and "shop talk" information to be found throughout this manual to help you obtain the most pleasure from the use of your vehicle.

The information in this manual reflects the most current available to us at the time of publication. If you find the components in your recreation vehicle vary significantly from what is described in this manual, please disregard that section and follow the instructions provided by that particular component manufacturer. You should carefully read and understand this owner's manual which is a supplement to various other instructions supplied by the manufacturers of separately warranted products.

Keep this owner's manual in your recreation vehicle for handy reference. Get to know your new vehicle and how it operates. You should carefully read and understand these instructions and information supplied by manufacturers of separately warranted products, since they contain important operating, safety, and maintenance instructions. If you have questions that are not adequately answered by this manual or other booklets, consult your dealer. If he cannot satisfactorily answer your questions, he will call our staff or refer you to us for help.

Every effort has been made to provide you with a safe, dependable product. Your vehicle complies with applicable requirements of Federal Motor Vehicle Safety Standards, State Regulations, Canadian Standards Associations (CSA) where applicable, and complies with requirements of ANSI Standard A119.2, the nationally recognized "Standard For Recreation Vehicles – Installation of Plumbing, Heating and Electrical Systems." The Recreation Vehicle Industry Association (RVIA) and Canadian Standards Association (CSA) periodically inspect our production line and assist us in maintaining strict compliance with installation and safety standards for those systems. **Your follow-up with periodic safety inspections and a program of preventive maintenance is important for the continuation of safe and trouble-free operation.**

Camping is a great way to relax and enjoy the outdoors with your friends and family. Please remember to tread lightly on our beautiful land and leave only your footprints so that others may enjoy nature as much as you did.

The Jayco Family
Jayco, Inc.

SAFETY CONSIDERATIONS

The terms NOTE, CAUTION and WARNING have specific meanings in this manual.

A **NOTE** provides additional information to make a step or procedure easier or clearer. Disregarding a NOTE could cause inconvenience, but would not be likely to cause damage or personal injury.

A **CAUTION** emphasizes areas where equipment damage could result. Disregarding a CAUTION could cause permanent mechanical damage. However, personal injury is unlikely.

A **WARNING** emphasizes areas where personal injury or even death could result from failure to follow instructions properly. Mechanical damage may also occur.

Reporting Safety Defects

If you believe that your vehicle has a defect which could cause a crash, injury or death, you should immediately inform the National Highway Traffic Safety Administration (NHTSA) in addition to notifying Jayco, Inc.

If NHTSA receives similar complaints, it may open an investigation, and if it finds that a safety defect exists in a group of vehicles, it may order a recall and remedy campaign. However, NHTSA cannot become involved in individual problems between you, your dealer or Jayco, Inc.

NHTSA
U.S. Department of Transportation
Washington, D.C. 20590
Phone: 1-800-424-9393
Washington, D.C. Area: 368-0123

Customer Relations Dept.
Jayco Incorporated
P.O. Box 460, Middlebury, IN 46540
Phone: 1-877-825-4782 or 1-219-825-0608
Business Hours: 8:00-5:00 Mon.–Fri. E.S.T.

You can also obtain other information about motor vehicle safety from the Hotline.

Safety in Using LP Gas

You should check for leaks at the connections on the LP gas system soon after purchase and initial filling of LP tanks, and continued periodic checks of the system are recommended. Your vehicle was manufactured to provide you with full access to all gas line connections. Leaks can be found with a soapy water solution, which **does not contain ammonia or chlorine**, applied to the outside of the gas piping connections: the soap will bubble at the leak. **DO NOT USE FLAME OR LIGHTED MATCHES TO TEST FOR LEAKS.** Tightening connections will usually stop leaks. When tightening connections, use two wrenches with opposing torque to prevent twisting of copper tubing. If this does not solve the problem, ask an authorized dealer's service department to make the necessary tests and repairs.

ALTHOUGH THE MANUFACTURER AND DEALER HAVE PERFORMED TESTS FOR LEAKAGE, THIS CHECK IS RECOMMENDED DUE TO THE VIBRATION ENCOUNTERED DURING TRAVEL.

LP gas is heavier than air therefore leaking gas tends to flow to low places and will sometimes pocket in low areas, such as the floor. LP gas can usually be detected by an identifiable odor similar to onions or garlic. Never light a match or allow any open flame in the presence of leaking gas.

It is very important to have the LP gas turned off during refueling of tow vehicles. Some states prohibit traveling with LP container(s) open, especially in underground tunnels.

Never allow gas containers to be filled above the liquid capacity indicated on the container. If a container is overfilled, liquid gas may flow through the regulator causing it to freeze and/or introduce a dangerous excessive gas pressure into the lines. In addition, an overfilled container placed in direct sunlight may expel excess gas through the relief valve and be susceptible to ignition by any nearby open flame.

Electrical System Safety

Circuit breakers and fuses are installed to protect electrical circuits from overloading. Do not make unauthorized changes to circuitry or add on fixed appliances yourself. If you wish to make changes, consult your dealer and he will assist you in obtaining a safe installation.

An approved power supply cord has been supplied with the vehicle. Always use this cord for hook-up to the 120-volt AC source. Note that the cord has a three pin plug, which provides proper grounding through the third (round) pin. Grounding is your personal protection from electrical shock.

WARNING: Do not use an adapter, cheater, or extension cord that will break the continuity of the grounding circuit connected to the third pin. NEVER remove the grounding pin to connect a non-grounded, two-prong receptacle. Any deviation from this will potentially cause a fire from overheating.

Safety When Emergency Stopping

Pull off the roadway as far as possible for emergency situations and turn on the vehicular hazard lights. If necessary, display your road flags and/or reflective triangular highway warning devices.

NOTE: Always carry road flags and/or reflective triangular highway warning devices to be displayed when necessary.

Additional Safety Considerations

Warning: For traveling safety, it is extremely important to read and understand the towing, hitching and loading cargo information provided in Chapter 3. If you do not understand the information provided, please consult your dealer or Jayco owner representative.

- Sanitize the fresh water supply system periodically (see sanitizing instructions).
- Prevent water connection fittings from coming in contact with the ground or drain hose to reduce chance of contamination.
- Enlist services of a qualified or certified RV technician to repair and maintain gas or electrical appliances.
- Always have a serviceable fire extinguisher placed in an easily accessible location.
- Ensure that tires are in good condition and properly inflated. Proper inflation should be monitored closely. Neglecting to do so could result in overheating of a tire, which could result in a blowout.

- Check and tighten wheel lugs after the first 10 miles, 25 miles, and 50 miles (15, 40 and 100 kilometers) when new and after a wheel has been removed. Check periodically thereafter.
- Check brakes in a safe area - not while traveling a busy highway.
- Block travel trailer wheels solidly before unhitching.
- Observe the warning labels attached to your vehicle concerning LP gas, water, electricity and loading.
- Before leaving the camping area towing a conventional travel trailer, double-check the following list of items:
 - ✓ Insure that the safety pin or locking lever is seated.
 - ✓ The breakaway cable is attached to the tow vehicle.
 - ✓ The jack is raised so that it cannot touch the ground.
 - ✓ The dolly wheel is removed.
 - ✓ The 120-volt electrical cord is properly stored.
 - ✓ The safety chains are connected.
 - ✓ All interior lights are off.
- For towing a fifth-wheel travel trailer:
 - ✓ Insure that the fifth-wheel landing gear is raised.
 - ✓ The 120-volt electrical cord is properly stored.
 - ✓ All interior lights are off.
- Observe the maintenance chart in Chapter 7 related to your respective unit.

INSURANCE

As with your automobile, it is important that you protect yourself and others with insurance coverages for personal liability, theft, collision, property damage, etc. Your dealer will assist you in obtaining appropriate insurance for your protection or you may check with the company which provides your automobile insurance.

EXTENDED USE

Your new travel trailer has been built for enjoyment in a recreational manner. It is not intended to be used as full-time living quarters.

CAUTION: Continuous living in your travel trailer could cause accelerated wear and damage to components.

COLD WEATHER USE

- Use of this travel trailer during cold weather will require more protection. Using skirting or insulation below floor level will provide additional protection if you are camped in one area for an extended period.
- Proper care should be taken with the fresh water and drainage systems to avoid freezing problems. Consult your local dealer or RV supply house for advice on heat tapes, etc.
- Adequate gas and electrical supply is needed along with protection from possible freeze-ups on gas regulator. The furnace will substantially increase battery draw and LP use.
- During cool weather usage, ventilation or addition of a dehumidifier may be required to reduce condensation. **See next section for important information on controlling condensation.**

CONDENSATION

Condensation is a natural phenomenon. The amount of condensation will vary with the climate conditions, particularly the relative humidity. Condensation occurs because there is water vapor present in the air, which is added by breathing, bathing and cooking. The water vapor collects where there is available air space, and when the temperature reaches the 'dew point' the water vapor in the air condenses and changes to liquid form. Most people have experienced a similar phenomenon when moisture forms on kitchen windows and bathroom mirrors during cool weather.

Proper ventilation and, if needed, the use of a dehumidifier will assist in controlling the condensation. Many RV and marine dealers carry small dehumidifiers especially sized for recreation use. Condensation causes dampness, mildew, staining and if allowed to continue at high levels, damage to the paneling and wood structures.

CHAPTER 2 OBTAINING SERVICE

WARRANTY REGISTRATION

Warranty Registration and Customer Delivery Form

Dealer is to assure that this form is promptly completed and returned to Jayco within ten (10) working days after delivery.

Jayco, Inc.
P.O. Box 811
604 South Main Street
Hendricks, Indiana 46540
(317) 838-0222

| | |
|---------------------------------------|--|
| MAKE/TYPE/YEAR _____ | DEALER'S NAME _____ |
| ADDRESS _____ | ADDRESS _____ |
| CITY _____ STATE _____ ZIP CODE _____ | CITY _____ STATE _____ ZIP CODE _____ |
| TITLE AND UNIT _____ | MODEL/TYPE/PRICE (MARKET AS SHOWN AT DELIVERY) |
| JAYCO SERIAL NUMBER _____ | CHASSIS VIN (FROM FTR NUMBER) _____ |

ALL ITEMS MUST BE MARKED OFF BY THE DEALER IN THE CUSTOMER'S PRESENCE INDICATING PERFORMANCE OR INSTRUCTION AS REQUIRED. PLEASE MARK LACI (L) OR OR (O) OR NA (NOT APPLICABLE).

| | | |
|--|---|--|
| <p>1. ELECTRICAL SYSTEM</p> <input type="checkbox"/> 110-Volt System <input type="checkbox"/> 12-Volt System <input type="checkbox"/> All Interior Lights/Recept <input type="checkbox"/> All Exterior Lights/Recept <input type="checkbox"/> Battery - Full Charge and Maintenance <input type="checkbox"/> Converter Operation and Use <input type="checkbox"/> Monitor Panel and Maintenance <input type="checkbox"/> Operation and Maintenance of Slideout <input type="checkbox"/> Phone and Cable TV <input type="checkbox"/> Roof Air <input type="checkbox"/> Radio/Cassette <input type="checkbox"/> TV <input type="checkbox"/> Microwave <p>2. FOLDING CAMPER SET-UP</p> <input type="checkbox"/> Complete Set Up and Closing Demonstration <input type="checkbox"/> Proper Leveling <p>3. LP GAS SYSTEM</p> <input type="checkbox"/> Location and Maintenance of LP Lines and Connections <input type="checkbox"/> Maintenance and Operation of Regulator <input type="checkbox"/> Appliance, Refrigerator and Furnace Vents | <p>4. WATER/PLUMBING SYSTEMS</p> <input type="checkbox"/> Water Lines <input type="checkbox"/> Faucets <input type="checkbox"/> Winterizing <input type="checkbox"/> Water Intake/Drain Lines <input type="checkbox"/> Outside Shower <input type="checkbox"/> Shower <input type="checkbox"/> Holding Tank <input type="checkbox"/> Toilet <p>5. APPLIANCES AND SAFETY EQUIPMENT</p> <input type="checkbox"/> LP Gas Manometer Test (Check for leaks - Regulator needed and reset) <input type="checkbox"/> Set Gas Pressure At _____ IN Water Column <input type="checkbox"/> Furnace and Thermostat Range and Oven <input type="checkbox"/> Water Heater and Bypass <input type="checkbox"/> Coffee Maker <input type="checkbox"/> Refrigerator <input type="checkbox"/> Break-away Switch <input type="checkbox"/> Tires - Correct size and inflate to sidewall pressure specs <input type="checkbox"/> Door Locks/Keys <input type="checkbox"/> Wheel Lugs (Tighten to specs for FL, LB Turnpin) - Review Maintenance <input type="checkbox"/> Tighten at 10, 25, 50 miles. | <p>6. RUNNING GEAR</p> <input type="checkbox"/> Brake Adjustment and Maintenance <input type="checkbox"/> Swearing Lubrication and Maintenance <input type="checkbox"/> Brake Wire Connections <input type="checkbox"/> Hydraulic Brake Line and Maintenance <input type="checkbox"/> A-Frame/Coupler Operation <input type="checkbox"/> Operate and Lube Jacks <p>7. GENERAL APPEARANCE</p> <input type="checkbox"/> Interior/Exterior Trim <input type="checkbox"/> Exterior Finish <input type="checkbox"/> Bumper, Steps, A-Frame, Rub Out and Touch Up as Needed <input type="checkbox"/> Window and Roof Sealant <p>8. Motorized Products</p> <input type="checkbox"/> Check all Fluid Levels <input type="checkbox"/> Check all Door and Window Locks <input type="checkbox"/> Chassis Prop as Recommended by the Manufacturer |
|--|---|--|

DEALER INSTALLED OPTIONS (Dealer installed options are not covered under Jayco's limited warranties.)

OWNER/DEALER INSPECTION

| | |
|--|--|
| 1. Exterior and Interior Finish. 2. Operate all appliances and discuss maintenance. 3. Review operation, maintenance and safety of LP system. 4. Explain weight ratings, limitations, and proper load distribution. | 5. Operate all fresh water and plumbing components including faucet, shower toilet and drain hookups. 6. Review low vehicle, hitch and sway control set-up - test drive. 7. Complete review of owner manual and highlight safety issues and maintenance. |
|--|--|

I HAVE COMPLETED THE ABOVE INSPECTION ON THIS FAMILY CAMPING VEHICLE AND HAVE TAKEN A TEST DRIVE AT THE TIME OF PURCHASE. I NOTED:

I RECEIVED A COPY OF THE JAYCO LIMITED WARRANTY BEFORE I PURCHASED THIS VEHICLE AND I UNDERSTAND THAT IT IS DESIGNED TO BE USED ONLY FOR RECREATIONAL CAMPING AND TRAVEL.

I AGREE TO THE TERMS ON THE REVERSE SIDE, AND UNDERSTAND THAT I WILL BE REQUIRED TO ARBITRATE ALL MY CLAIMS CONCERNING MY RECREATIONAL VEHICLE RATHER THAN GOING TO COURT.

THE PURCHASER HAS INSPECTED OR BEEN GIVEN THE OPPORTUNITY TO INSPECT THE VEHICLE AND TAKE THE TEST DRIVE, SUPPLIED THE INFORMATION ABOUT HIS/HER NAME AND ADDRESS, BEEN GIVEN THE OPPORTUNITY TO MAKE NOTATIONS IN THE SPACE PROVIDED AND OBSERVED OR RECEIVED SATISFACTORY EXPLANATIONS ABOUT ALL ITEMS LISTED ABOVE.

| | | |
|------------|-----------------------------|--------------------------|
| DATE _____ | PURCHASER'S SIGNATURE _____ | DEALER'S SIGNATURE _____ |
|------------|-----------------------------|--------------------------|

Main Copy: Jayco Copy Copy: Dealer Pink Copy: Customer

STANDARD 1/8"

INFORMAL DISPUTE RESOLUTION AGREEMENT

I am entitled to receive a copy of this Agreement, and I may review it with my attorney before signing. I and anyone making claims on my behalf, or through me, shall submit any and all claims I may have in connection with my recreational vehicle (RV) against any retail dealer, manufacturer, or supplier of component parts, to binding arbitration under the federal Arbitration Act, 9 U.S.C. § 1-14, to the extent permissible under federal law. I agree that if I have a claim relating to my RV, I will allow the dealer and Jayco to inspect it and make necessary repairs. If my claim is not then satisfied, I will notify Jayco and binding arbitration proceedings will be held after I have paid an initial fee of \$125 to the American Arbitration Association and I cannot pursue my claim in court or in any administrative proceeding. Arbitration will be administered by the American Arbitration Association (AAA), pursuant to its Commercial Arbitration Rules, unless and until Jayco designates a different administrator, in which event a notice will be mailed to your last known address. If my claim is less than \$10,000, Jayco will pay the initiation fee and arbitrator's fees in excess of \$125, and the arbitrator shall not award damages in excess of \$10,000. If my claim exceeds that amount or is not specified, I will pay one-half of the fees and costs in excess of \$125. I, the dealer, and Jayco will each pay their own costs and expenses in connection with the arbitration hearing. The claim will be heard by a single arbitrator, and will be held thirty (30) days after the claim is filed, unless all parties agree to a later date. The arbitrator shall be selected from a panel named by the AAA, pursuant to its rules. The arbitrator shall be permitted only to award actual damages for financial loss, and shall not award damages for personal injury (or mental anguish, or other intangible claims), or punitive damages. Statutes of limitation, which would apply to a court proceeding for my claim, will apply to commencement of arbitration proceedings. If I default on any obligation to a lender in connection with my RV, my lender may exercise all of its rights without regard to this agreement. If I file a claim in court without having first complied with this agreement, I will be required to pay all fees, costs, and expenses, including attorneys' fees, for dismissal or referral to arbitration. This agreement will apply to me, my heirs and assigns, and anyone who purchases or leases my RV from me or operates or occupies it with my permission or without objection by me. Nothing in this agreement enlarges my rights or gives me any rights or claims I would not otherwise have. **FOR INFORMATION ABOUT HOW TO FILE A CLAIM OR ABOUT THE ARBITRATION PROGRAM, CALL JAYCO AT 219-825-0608, OR THE AMERICAN ARBITRATION ASSOCIATION AT 800-778-7879.**

SERVICE PROCEDURES

Basic Service Procedures

We are interested in your satisfaction. Only by having your complete confidence and satisfaction with our product and its service can we assure our continued success as manufacturers of recreation vehicles. We have found that continuing a pleasant and effective relationship through our dealers is equally as important as maintaining the technical excellence of our product. Your authorized dealer will cordially assist you in providing service, maintenance, selection of options and instructions concerning the operation of your vehicle.

Should you have a problem with service, please follow these instructions in sequence.

1. Contact your selling dealer's service department for an appointment. Describe to the best of your knowledge the nature of the problem.
2. Contact the owner or General Manager of the dealership should the initial attempt fail with the service department.
3. If further assistance is needed contact:

Customer Relations Dept.
Jayco Incorporated
P.O. Box 460
Middlebury, IN 46540
Phone: 1-877-825-4782 or 1-219-825-0608
Business Hours: Monday – Friday 8:00 – 5:00 EST

Give all the above information as requested along with the serial number of the unit in question and we will make every attempt to resolve your problem.

Please bear in mind that most problems arise from misunderstandings concerning warranty coverage and service. In most instances, you will be referred to the dealer level and problems will be resolved with the dealer's facilities and personnel.

Dealer

Your authorized Jayco dealer has inspected and serviced your new Jayco travel trailer and is authorized to service and maintain your travel trailer as needed. All warranty repairs are to be performed by the selling dealer unless Jayco gives prior approval.

Some RV dealers may be authorized service centers for certain manufacturers of products warranted separately. Check with your dealer before contacting others to reduce delays. If your Jayco dealer is not an authorized service center for the product in question, they will be able to assist you in obtaining authorized service.

Factory

A factory service department is operated at our Middlebury, Indiana, manufacturing facility. Should your Jayco RV be in need of repairs and your dealer recommends that the factory make the necessary repairs, it may be returned to our plant upon following these procedures:

- A. You or your dealer must make an appointment prior to returning it to the factory service department.
- B. All transportation costs are the responsibility of the owner. You may need to arrange for alternative accommodations for some types of repairs. Please be prepared accordingly.

Parts

Parts are available at most Jayco dealerships or your dealer can order parts for you as needed. Should you be unable to find a dealer in your local area, contact our Customer Service Department at 877-825-4782 or 219-825-0608 and we will assist you by providing parts through an authorized dealer.

Owner's Responsibility

As a new owner of a Jayco recreation vehicle, you are responsible for regular and proper maintenance. This will help you prevent conditions arising from neglect that are not covered by your Jayco Limited Warranty.

Maintenance service should be performed in accordance with this owner's manual and any other applicable manuals.

As the owner, it is your responsibility and obligation to return the RV to an authorized dealer for repairs and service. Reference your Jayco Limited Warranty for additional information. Because the authorized dealer where you purchased your RV is responsible for its servicing before delivery and has an interest in your continued satisfaction, we recommend that inspection, warranty and maintenance services be performed by the dealership.

If you are traveling and are unable to locate an authorized Jayco dealer, or an authorized dealer for the component needing service, please call our customer service office at 877-825-4782 or 219-825-0608 or contact your selling dealer for assistance.

NOTE: Service at a non-authorized Jayco dealer should have prior authorization. You will be asked to return any mechanical parts replaced before reimbursement consideration is made. Unauthorized or improper repairs may void the warranty on that component.

Please keep your owner's manual, your copy of the warranty registration form and any other related papers in your RV.

CHAPTER 3

USING YOUR TRAVEL TRAILER

In this chapter you will find helpful information to assist you in preparing, traveling and using your travel trailer.

EQUIPMENT

Tow Vehicle

WARNING: TOWING YOUR TRAILER WITH AN INADEQUATE TOW VEHICLE OR HITCH ASSEMBLY MAY LEAD TO EXCESSIVE SWAYING OR OTHER LOSS OF CONTROL, WITH PERSONAL INJURY OR PROPERTY DAMAGE RESULTING FROM ROLLOVER OR COLLISION. Make sure to read and understand Chapter 3 on using your recreation vehicle.

Consult experts on hitch and tow vehicles before you tow your trailer. Jayco does not recommend or endorse particular tow vehicles or hitch assemblies. Review the compatibility of your tow vehicle with the trailer you will be towing. As a minimum requirement, the gross vehicle weight rating (GVWR) of your trailer must not exceed your tow vehicle's rated towing capacity. Know your loaded hitch weight and select a hitch that is adequate for that weight. You, as the owner, are responsible for the safety and compatibility of your tow vehicle and trailer selections. You are responsible for the maintenance and proper connection of your tow vehicle, hitch assembly, and trailer. Do not exceed the towing or cargo capacity of your tow vehicle and do not exceed the GVWR of the trailer. You should clearly understand how your particular tow vehicle capacities are calculated. Make sure your tow vehicle is mechanically sound for your intended usage and pay particular attention to suspension components, tires, and tire pressure. Anti-sway devices and weight distributing hitches should be used with all Jayco towable products (excluding fifth wheels, which use a different type of hitch), with the guidance of a trained hitch installer. Towing a trailer is not the same as driving a passenger car or a single vehicle. Many states have lower speed limit requirements for tow vehicle/trailer combinations. Obey all traffic laws and use your seatbelts at all times. Don't exceed 55 MPH when towing a trailer. Consult an expert for specific driver education when towing a trailer. RV driving schools and some RV clubs may offer helpful driving seminars as part of their club activities.

Begin your camping experiences by using a tow vehicle that will adequately transport your travel trailer to and from your destinations. You must use the Gross Vehicle Weight Rating (GVWR) factor as a measuring tool to match the capability of your selected tow vehicle. Ford, Chrysler-Daimler and Chevrolet provide trailer towing guides for their products, as do most auto and truck manufacturers. Ask your local automotive dealer for a copy or contact the factory's customer assistance for information. Most tow vehicles have towing packages available as an option and these should be given serious consideration. Tow vehicles with longer wheel bases perform better and are more stable than short wheel bases, such as those on most SUV's. The condition of the suspension system in your tow vehicle is also important and will affect your trailer's handling. Become familiar with and understand how to properly distribute loads in your trailer and tow vehicle and

never overload either unit. Make sure your tow vehicle is in good mechanical condition and maintenance is up to date. When you tow a RV, you must drive differently than you do when driving a single vehicle. Practice hooking up, driving, backing up and braking in a safe environment (with vehicles fully loaded as if for normal travel if possible) or seek out professional instruction. Obey all posted speed limits. Be prepared to drive slower and if you must pass, do so with the utmost care, particularly in strong winds. When being passed by or when passing semi-trailers or large buses, be prepared for displaced air, as it can be severe enough to cause trailer sway. Understand how trailer brakes, tow vehicle brakes, acceleration can affect your control of the trailer when you experience trailer sway as well as proper hitches and sway controls.

There are many excellent publications about traveling with a RV. We strongly recommend you make use of available resources at your local library, the Internet or bookstore.

Hitches – Conventional Travel Trailer

After choosing your tow vehicle, it is very important to install a hitch system with weight distributing bars to accommodate your travel trailer. The selection and installation should be performed by a professional hitch service which may or may not be your selling dealer.

A Class IV weight distribution hitch package is suggested. The rating of the hitch package should be equal to or greater than the trailer's GVWR and the hitch weight. The very equipment that sometimes gives autos, trucks and sport utility vehicles a softer ride can accentuate swaying when pulling a travel trailer. Conversely, suspension that is too stiff will increase vibration, bounce and accelerate wear of your tow vehicle and travel trailer. It is important that your travel trailer be level when hitched to your tow vehicle. Educate yourself to protect you, your family and other motorists. Short wheel bases on tow vehicles can contribute to sway.

WARNING: We recommend the use of an anti-sway device or sway control for all tow vehicle/trailer combinations.

CAUTIONS:

- Using an oversized or undersized hitch can cause damage to the frame of your travel trailer.
- Jayco, Inc. cannot be responsible for the suspension system of the tow vehicle. The final ball height after the travel trailer is completely hooked up is a factor to be considered when towing a travel trailer. To avoid overloading your travel trailer axles and minimize possible handling difficulties, your travel trailer should be level when hooked to your tow vehicle.
- Do not overload your tow vehicle.

Hitch Height Specifications - Conventional Travel Trailer

Note: To determine the hitch height for your model, make sure that the travel trailer is level. Measure from inside the hitch coupler to the ground. Record this number in the box at the side for future reference. The table below contains an average measurement obtained by measuring several units with different options. This gives you a target range for what your unit will measure.

**This unit
hitch height is:**

| Eagle | Qwest | Ball Height | Ball Size |
|---------|-------|-------------|-----------|
| | All | 21" | 2-5/16" |
| 302 FK | | 20-1/2" | 2-5/16" |
| 312 FKS | | 21-1/2" | 2-5/16" |
| 314 BHS | | 21-1/2" | 2-5/16" |
| 266 FBS | | 21-1/2" | 2-5/16" |
| 296 FBS | | 21-1/2" | 2-5/16" |
| 316 FB | | 21" | 2-5/16" |
| 264 BH | | 21" | 2-5/16" |
| 262 FK | | 21" | 2-5/16" |
| 304 BH | | 21" | 2-5/16" |
| 246 FB | | 21" | 2-5/16" |
| 376 FBS | | 21-1/2" | 2-5/16" |
| 350 FSS | | 21-1/2" | 2-5/16" |

The Hitching Procedure – Conventional Travel Trailer

Hooking up a conventional travel trailer is not difficult and will become easier with practice. The following procedure will help you until you become more experienced.

1. Block wheels.
2. Turn crank on jack to raise tongue of travel trailer above hitch ball on hitch.
3. Open coupler latch on travel trailer hitch.
4. Back tow vehicle into proper position.
5. Turn crank on jack to lower coupler onto ball hitch.
6. Close coupler latch after completely seated.
7. Install weight distributing bars (equalizers) as per recommendations from hitch supplier, when required.
8. Remove dolly wheel and retract tongue jack to its maximum height.
9. Attach breakaway switch cable to tow vehicle.
10. Attach safety chains as shown in Figure 3-1.
11. Plug in your 12-volt DC electrical connector from tow-vehicle to travel trailer.
12. The following items should be inspected prior to your journey:
 - All lights should be in working order.
 - Stabilizer jacks should be in the retracted position.
 - Entrance steps should be in the retracted position.
 - Refrigerator door should be closed and locked.

- All loose items should be secured.
- Brakes should be tested for operation prior to entering roadway.
- Tire pressure should be checked and maintained per the tire pressure stamped on the tire sidewall.

The Safety Chain – Conventional Travel Trailers

There are different safety chain requirements determined by the various state laws. Your vehicle is equipped with chains to meet SAE standard requirements for maximum gross trailer weight. Always have the safety chains attached when towing. Install them as shown below so they do not restrict sharp turns, but tight enough so they do not drag on the ground.

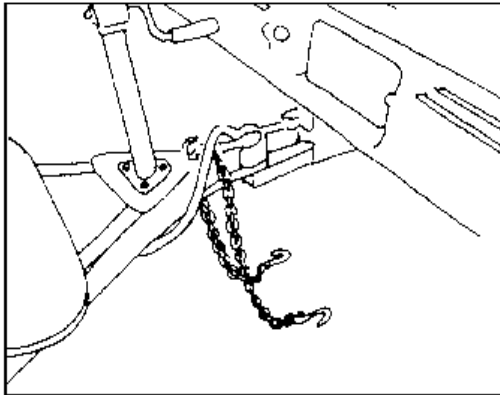

1. Inspect chains to determine if they are properly attached to trailer frame.

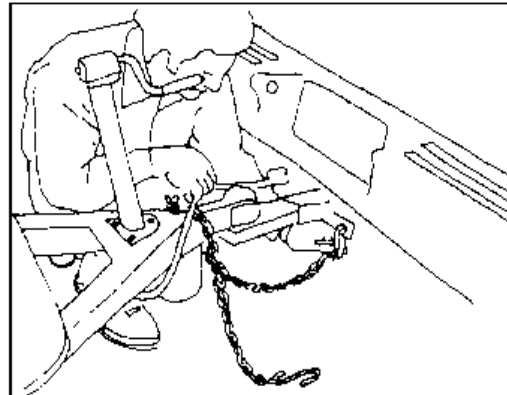

2. Criss-cross left chain and attach to right mounting slot in trailer hitch.

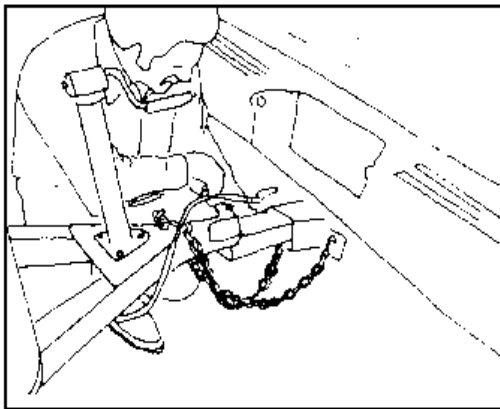

3. Repeat step 2 with right chain. Slack for each length should be the same but not more than necessary to permit the vehicle to turn at their minimum radius.

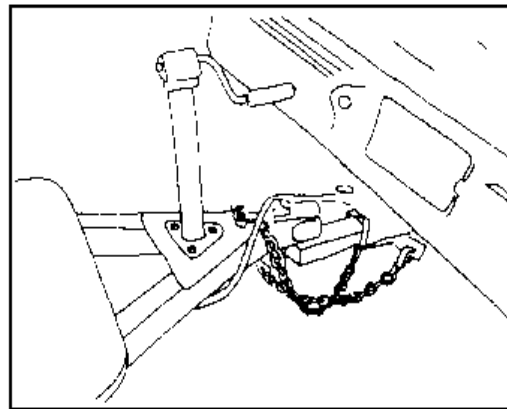

4. Properly mounted safety chain. Note that the jack is fully raised and dolly wheel removed.

Fig. 3-1

Hitches – Fifth-Wheel Travel Trailer

Different types of hitches are available for pickup trucks to tow fifth-wheel travel trailers. The best type of hitch is one that is bolted directly to the floor of the truck box through the frame.

Another type of hitch is the mini-hitch. The mini-hitch has two brackets attached to the truck box, and is placed over the fender. This type of hitch generally does not provide frame support for strength.

Hitch Height - Fifth-Wheel Travel Trailer

There is no recommended hitch height for fifth-wheel travel trailers. The pin box is adjustable at two inch intervals for variance in trucks and their suspension systems. Always travel with the truck and travel trailer as level as possible.

The Hitching Procedure – Fifth-Wheel Travel Trailer

1. Block wheels.
2. Make sure the hitch lever is in its open or “cocked” position unless it has been designed to open automatically.
3. Back the truck so the hitch encircles the fifth-wheel travel trailer pin.
4. A gentle contact of the hitch saddle against the pin will cause the mechanism to close.
5. Secure the hitch lever as specified by manufacturer.
6. Be sure to raise the fifth wheel landing gear all the way up.
7. Attach breakaway switch cable to tow vehicle.
8. Plug the 12-volt DC electrical connector from tow vehicle to fifth-wheel travel trailer.
9. Raise the tailgate of tow vehicle, if applicable.
10. When unhitching, make sure you do not forget to lower the tailgate.

Towing

While towing your Jayco travel trailer, you need to be aware of the extra weight behind your vehicle. The following list contains some pointers to remember while traveling.

- With the travel trailer attached, you will have slower acceleration and require greater distance to stop.
- Make sure you have enough area at corners when turning. Wider turns are necessary. Use your turn signals for your own safety.
- When passing or changing lanes, take into consideration the overall length of your travel trailer and allow ample distance and time.
- Use your rearview mirrors frequently to observe your travel trailer and traffic conditions.
- When being passed by a large truck or bus, be prepared for displaced air as it may cause you to sway slightly.
- Upon climbing steep, long grades and again descending, use lower gears even before it seems necessary. Use your brakes smoothly and evenly.

- Decrease your speed for safety! Most states require cars pulling trailers to maintain slower speeds, usually the same as truck traffic.
- Drive slowly during wet and icy conditions to ensure better control of your vehicle.
- Check all exterior lights before each trip.
- Obey traffic laws, allow extra time for stopping and decrease speed when visibility is limited or roads are wet.
- Have a safe and wonderful trip!

If towing a trailer is new for you, please take time to practice towing, parking and backing skills prior to traveling. Your dealer can answer many of your questions, but nothing replaces practice. We recommend you find a large and quiet parking lot to practice your skills.

TRAVELING

Weights and Cargo Capacity

For safety reasons, it is very important to provide RV owners with the most accurate weight information available. The “Federal Certification” label (Fig. 3-2), located on the roadside front corner of the travel trailer is shown here. Several weight terms an owner needs to understand when operating a towable recreation vehicle are defined on the “Trailer Weight Information” label (Fig. 3-3), which will be found on the back of a cabinet door in the kitchen base cupboard. An important term in addition to the label information is the GAWR (Gross Axle Weight Rating). The GAWR is the maximum weight rating that components of each axle are designed to support (i.e. tires, brakes, springs, axle). Make sure that you review and understand the weight terms and information.

The weight provided in the Jayco literature for your travel trailer is based on standard equipment on that particular model and is “dry” (i.e. no liquids or cargo). Remember that any options or personal cargo added must be subtracted from the available cargo capacity. **Never exceed the gross vehicle weight rating of your travel trailer.**

WARNING: Do not add accessories or components that are not safe and appropriate for this product. Jayco, Inc. DOES NOT provide warranty coverage for equipment installed by dealer or owner for such modifications or additions. Any such modifications effect weight specifications, AND CAN ADVERSELY AFFECT HANDLING AND STABILITY OF THE UNIT, AS WELL AS ACCELERATE WEAR TO OTHER COMPONENTS.

| | | | |
|--|---------------------|--|-------|
| MANUFACTURED BY: JAYCO, INC. | | DATE: _____ | |
| FABRIQUÉ PAR: | | | |
| GVWR/PNBV KG. | VIN/NIV | PRESS./ COLD INFL. PRESS. DE GONFL. À FROID | |
| _____ | _____ | _____ | |
| | SIZE/DIMENSION | | |
| GAWR/PNBE | TIRE/PNEU RIM/JANTE | PSI/LPC | KPA |
| _____ | _____ | _____ | _____ |
| | FRONT / DEVANT | _____ | _____ |
| | INT/ CENTRAL | _____ | _____ |
| | REAR/ ARRIÈRE | _____ | _____ |
| TYPE OF VEHICLE/TYPE DE VÉHICULE | | TRAILER/REMORQUE | |
| THIS VEHICLE CONFORMS TO ALL APPLICABLE U.S. FEDERAL MOTOR VEHICLE SAFETY STANDARDS AND STANDARDS PRESCRIBED UNDER THE CANADIAN MOTOR VEHICLE SAFETY REGULATIONS IN EFFECT ON THE DATE OF MANUFACTURE SHOWN ABOVE. | | CE VÉHICULE EST CONFORME A TOUTES LES NORMES QUI LUI SONT APPLICABLES EN VERTU DU REGLÈMENT SUR LA SÉCURITÉ DES VÉHICULES AUTOMOBILES DU CANADA EN VIGUER À LA DATE DE SA FABRICATION CI-DESSUS. | |

Fig. 3-2

TRAILER WEIGHT INFORMATION

VIN or SERIAL NUMBER _____

MODEL _____

GVWR (Gross Vehicle Weight Rating) is the maximum permissible weight of this trailer when separated from the tow vehicle.

UVW (Unloaded Vehicle Weight) is the total weight of this trailer as manufactured at the factory when separated from the tow vehicle. If applicable, it includes full generator fuel, engine oil, and coolants.

CCC (Cargo Carrying Capacity) is equal to GVWR minus each of the following: UVW, full fresh (potable) water weight (including the water heater), full LP-gas weight.

GCWR (Gross Combination Weight Rating) means the value specified by the trailer manufacturer as the maximum allowable weight of this trailer with its towed trailer or towed vehicle.

**The GCWR of this trailer is: \emptyset

CARGO CARRYING CAPACITY (CCC) COMPUTATION

Pounds / Kilograms (kg.)

GVWR
Minus UVW
Minus fresh water weight of __gallons @ 8.33 Lbs./gal. ...
Minus LP-gas weight of ____ gallons @ 4.24 Lbs./gal.
CCC for this trailer*

*Dealer installed equipment will reduce the CCC.

**This trailer is not recommended or intended to be used to tow any other vehicle or trailer.

CONSULT OWNER MANUAL(S) FOR SPECIFIC WEIGHING INSTRUCTIONS AND TOWING GUIDELINES.

Fig. 3-3

Loading Cargo

Packing equipment requires serious consideration. All cargo should be distributed evenly with the heaviest items stored in the lower cabinets. Heavy items must be secured to prevent weight shifts during travel. Additional weight behind the axle should be kept to a minimum.

CAUTION: DO NOT overload your travel trailer. Please follow the GVWR when loading your Jayco travel trailer.

When loading is completed, it is strongly suggested that you drive to a large scale and have your travel trailer weighed. If you are over loaded, it is advisable that you remove some of your cargo or liquids.

WARNING: The rear bumper on the frame of conventional travel trailers and fifth-wheel travel trailers is not designed to carry over 100 pounds (45 kilograms). Never add items such as generators, motorcycle racks, heavy tool boxes, etc. to the back of your travel trailer. Installation of items exceeding 100 pounds (45 kilograms) could cause metal fatigue and weld stress. DO NOT tow a trailer behind your travel trailer. Your trailer frame and bumper are NOT designed to tow another trailer.

CAUTION: Damage from add-on equipment or improper loading is not covered by your Jayco Limited Warranty.

WARNING: We recommend that you DO NOT travel with waste in your holding tanks. Full holding tanks are not calculated into the cargo carrying capacity of the unit and the extra weight will greatly diminish the cargo weight available to you, possibly causing you to exceed the gross vehicle weight rating of the unit. This can damage suspension components, such as springs, tires and axles. If your model has the holding tanks located behind the axles, the weight of a full tank will reduce the hitch weight. Sway and other handling difficulties can be the result of the hitch weight being too light. If you are dry camping and cannot immediately empty the tanks, use caution when towing and maintain lower speeds for better control of the trailer until you reach a dumping station.

Weighing Instructions

To properly weigh your recreation vehicle, it should first be weighed, including the tongue weight, while detached from the tow vehicle. This actual overall weight must be less than or equal to the GVWR for safe operation. If the overall weight is greater than the GVWR, some contents must be removed until maximum GVWR limitations are achieved. Once the actual overall weight is determined and the recreation vehicle is within GVWR limits, the following weights should be determined:

1. The weight of complete recreation vehicle, while attached, but excluding the tow vehicle. This will result in the actual weight which is exerted on all of the recreation vehicle tires. This weight may be subtracted from the overall recreation vehicle weight (above) to determine actual “tongue” weight.

2. With the recreation vehicle still attached to the tow vehicle, each wheel position should then be weighed separately to be sure each tire is not overloaded.

To determine the wheel position weight:

- Pull the recreation vehicle onto the scale so that only one tire is on the scale. Record the weight. Your trailer must remain as level as possible on the scale (even though an axle or side is not physically on the scale). Obviously, to obtain the side-to-side weights, there must be enough space on either side of the scale to accommodate the recreation vehicle being partially off the scale.
- To calculate the opposite side of the vehicle wheel position weight, subtract the first side's weight from the weight determined in step #1.

If there is a difference in the weights on one side of the vehicle as compared to weights on the other side, components (tires, wheels, brakes, springs, etc.) on the heavier side could be overloaded, even though the total axle load is within the GVWR. It is important to redistribute the load to avoid component failure, as well as to improve the handling characteristics of the vehicle.

Tires

The tires on all Jayco travel trailers are designed and built for recreational use. Tires are radial in design, having two steel cords and two polyester cords, offering excellent strength and mileage in all kinds of weather, when used as designed. See brochure in owner's packet.

NOTE: Tires are warranted by the tire manufacturer and are to be serviced and warranted by a service center. They are not to be returned to the dealer or travel trailer manufacturer.

Tire Chart

CONVENTIONAL TRAVEL TRAILERS

| Eagle | Qwest | Tire Size | Load Range | Max Load Per Tire |
|---------|-------|-------------|------------|-------------------|
| 264 BH | 240A | ST205/75R15 | C | 1820 |
| 262 FK | 244B | ST205/75R15 | C | 1820 |
| 302 FK | 270C | ST205/75R15 | C | 1820 |
| 316 FB | 256D | ST205/75R15 | C | 1820 |
| 304 BH | 292E | ST205/75R15 | C | 1820 |
| 246 FB | 294J | ST205/75R15 | C | 1820 |
| | 268F | ST205/75R15 | C | 1820 |
| 314 BHS | | ST225/75R15 | C | 2150 |
| 266 FBS | | ST225/75R15 | C | 2150 |
| 296 FBS | | ST225/75R15 | C | 2150 |
| 312 FKS | | ST225/75R15 | D | 2540 |
| 376 FBS | | ST225/75R15 | D | 2540 |
| 350 FSS | | ST225/75R15 | D | 2540 |

FIFTH-WHEEL TRAVEL TRAILERS

| Eagle | Legacy | Designer | Owest | Load Tire Size | Max Load Range | Per Tire |
|---------|-----------|---------------|-------|-------------------|-------------------|----------|
| 269 RD | | | 237A | ST205/75R15 | C | 1820 |
| | | | 265B | ST205/75R15 | C | 1820 |
| | | | 231C | ST205/75R15 | C | 1820 |
| | | | 253D | ST205/75R15 | C | 1820 |
| 277 RBS | | | | ST225/75R15 | C | 2150 |
| 243 RKS | | | | ST225/75R15 | C | 2150 |
| 313 RKS | | 27 RKS | | ST225/75R15 | D | 2540 |
| 263 RKS | | 32 RKS | | ST225/75R15 | D | 2540 |
| 285 BHS | | 33 RKS | | ST225/75R15 | D | 2540 |
| 293 RKS | | | | ST225/75R15 | D | 2540 |
| 311 RLS | | | | ST225/75R15 | D | 2540 |
| 325 BHS | | | | ST225/75R16 | D | 2540 |
| 281 RLS | | | | ST225/75R16 | D | 2540 |
| | | 29 RKS | | ST225/85R16 | D | 2540 |
| | 3110 RLS | 27 RKS (opt.) | | LT215/85R16 | E | 2680 |
| | 2930 RKS | 29 RKS (opt.) | | LT215/85R16 | E | 2680 |
| | 3310 RLS | 31 RLTS | | LT215/85R16 | E | 2680 |
| | 3230 RKS | 32 RLTS | | LT215/85R16 | E | 2680 |
| | | 32RKS (opt.) | | LT215/85R16 | E | 2680 |
| | | 33 RLS (opt.) | | LT215/85R16 | E | 2680 |
| | 3710 RLTS | | | LT235/85R16 | E | 3042 |
| | 3590 RLTS | | | LT235/85R16 | E | 3042 |
| | 3610 RLTS | | | LT235/85R16 | E | 3042 |

The air pressure must be kept at its suggested pressure because the weight capacity is related to tire pressure. Always check the tires when they are cold; such as before traveling at the beginning of the day. It is normal for air pressure to increase when traveling as tires will heat up. **DO NOT** release air pressure as tires become hot. If you do, the tires will then be under-inflated when they cool down.

Examine your tires frequently for unusual wear. Alignment, balance and bearing wear will effect tire wear.

CAUTION: It is recommended that the tire pressure be checked at the beginning of each journey to obtain the maximum life of the tires.

Inflation: Always follow inflation guidelines printed on sidewall of tire.

VINYL TIRE COVERS (Option)

Tip: To minimize the possibility of the tire “bleeding” through onto the tire cover, use a separator (garbage bag, paper, cloth, etc.) between the tire and the tire cover.

WHEEL LUGS

When the wheels are installed on your Jayco travel trailer, the lug nuts must be tightened at 90-120 foot pounds of torque.

WARNING: Axles on travel trailers do not drive or steer like automobile axles. The motion involved in being “trailed” adds stress that can loosen lug nuts, especially during the break in period. Wheel lugs can work loose. Check and tighten wheel lugs every 10 miles, 25 miles and 50 miles (15, 40 and 100 kilometers) when the camping trailer is new or a tire is changed, and then check and tighten after periods of extensive braking (such as coming down a steep grade) and every 3,000 miles (5000 kilometers).

After your first trip, check the wheel lugs periodically for safety. The wheel lugs should then be checked after winter storage, before starting a trip or following extensive braking. Size of bolts or nuts is 13/16". **Over torquing wheels is as dangerous as under torquing.**

FIRE EXTINGUISHER

A fire extinguisher is installed near the entrance door in the travel trailer. Be familiar with its location and operating instructions as printed on the extinguisher. It is too late to become familiar with an extinguisher when an emergency is at hand.

The fire extinguisher is a dry chemical, non-refillable extinguisher. Do not test this extinguisher. Doing so will cause loss of pressure making the extinguisher unusable. The extinguisher must be discarded and replaced by a new one if any use has occurred.

BRAKES

A controller should be installed below the dashboard of your tow vehicle to work in conjunction with the travel trailer brakes. Two types of controllers are available. The “hydraulic” controller operates through a steel line attached to the master cylinder of the tow vehicle’s brake system. The “electronic” controller, operates using electrical current. Reference the operating instructions provided with the controller for adjustment and operation procedures.

Electrical

The electric brakes on your travel trailer are designed to work in conjunction with the hydraulic brakes on your tow vehicle. To have the best brake performance on both systems, the travel trailer and tow vehicle must perform and operate together. Any attempt to use either brake system alone will cause accelerated wear and damage.

The battery in the tow vehicle is the primary power source that operates the brakes in your travel trailer. Keep your battery and charging system in working operation to ensure available energy when required.

From the battery, power is sent to the controller to provide the correct amount of current to brake the travel trailer. Use the tow vehicle's brake pedal for general operation on combined use of both brake systems. The controller's manual control is to be used only in special situations, such as slow movement or icy road conditions. In the open position, the manual control breaks the electrical current preventing brake engagement. When in the closed position, electrical current will flow to brake assemblies.

Wiring to operate your brakes must be the same size in both the tow vehicle and the travel trailer. A minimum of 14 gauge wire is recommended. Your travel trailer has 14 gauge from front end to brakes. Brake assemblies are wired in parallel, never in a series. Being parallel, there will be equal voltage and amperage at each brake assembly for equal braking capability and/or performance.

WHEN YOUR TRAVEL TRAILER IS NEW IT IS IMPOSSIBLE TO ADJUST YOUR BRAKE SHOES PRECISELY. IT TAKES APPROXIMATELY 1000 MILES AND/OR 50 MEDIUM TO HEAVY STOPS TO "BURNISH" FIT OR SEAT THE SHOES TO THE BRAKE DRUM. AFTER THIS INITIAL BREAK-IN PERIOD, YOU MUST ADJUST YOUR SHOES ACCURATELY FOR BEST PERFORMANCE AND INCREASED DURABILITY.

BREAKAWAY SWITCH

The breakaway switch is one of the most important parts of the travel trailer electric brake system. This system will apply the brakes of the travel trailer should it break away from the tow vehicle. The very instant a breakaway occurs, the pull pin, which is linked to the tow vehicle is pulled from the switch. The two contacts automatically close to complete the electrical circuit and apply the travel trailer brakes. A 12-volt DC battery is required to power the breakaway switch.

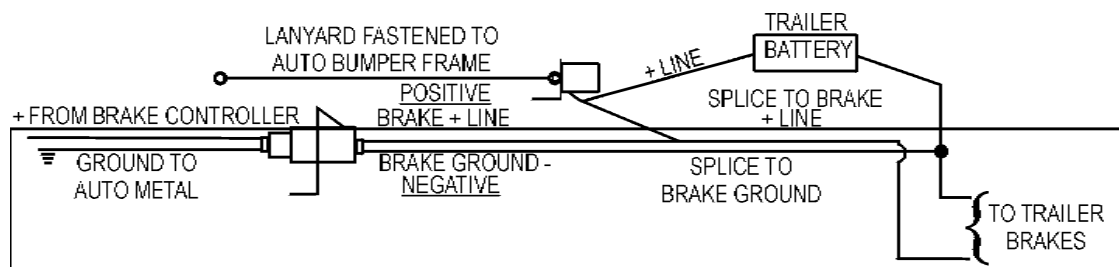

Fig. 3-4

WARNING: NEVER use this breakaway switch and travel trailer brake system as a parking brake. There would be a high amp draw on battery and convertor, potentially causing damaged wiring, connectors, and breakaway switch.

SLIDEOUT ROOM OPTION

The slideout room is designed for additional floor space and comfort. Mechanical components are gear driven and produced by Power Gear Company. Read ALL instructions in the next four pages before operation to become familiar with the system.

CAUTION: Do not place excessive weight in the slideout room.

Components

This slideout system has numerous major components and are as follows:

- One inner rail drive assembly to support room weight.
- A 12-volt DC motor and drive shaft that will operate the room using energy from an on-board recreation vehicle battery.
- A specially designed auto reset fuse has a load sensing capability that stops the motor when the room reaches its fully extended or retracted position.
- A manual override system that allows you to move the room in or out in the event of a power loss.

WARNING:

- Ensure that the travel trailer is level before operating the slideout room.
- Ensure there are no people or obstructions blocking the path of the room when it is moving.
- Keep away from the slide rails when the room is in motion.
- The gear assembly may pinch or catch on loose clothing causing personal injury.
- Always install travel bars for storage and transportation. (Eagle and Qwest models only.)
- Ensure the slideout is in the closed position prior to hooking the unit to the tow vehicle.

**Failure to follow these instructions
could result in serious injury or death.**

Operations (Manual Slideout – Resort Travel Trailers)

EXTENDING ROOM

1. The travel trailer must be level and the stabilizer jacks in the down position.

CAUTION: Additional support jacks are not needed under the slideout. Damage can occur to your slideout room from improper use of support jacks.

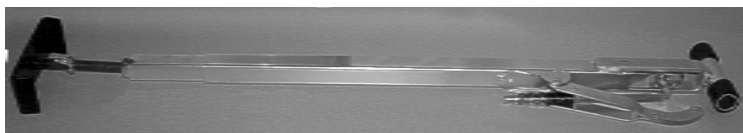

Fig. 3-5

2. For Eagle and Qwest models, remove “travel bars” (Fig. 3-5) from behind the top fascia board located above slideout room.
3. Unlock slideout locking mechanism.

4. Install the crank handle onto the crank shaft and turn until the room is extended. The crank shaft is located on the opposite side of the travel trailer as the main slideout room and is labeled, “Crank Override.”
5. When the slideout is in place put pressure on the crank handle to ensure a tight seal. This will ensure that the slideout is locked into a sealed position.
6. Engage slideout locking mechanism.

RETRACTING ROOM

1. Remove all objects from in front of the room. Check table leafs and chair positions.
2. Unlock slideout locking mechanism.
3. Install the crank handle onto the crank shaft and turn until the room is retracted. The crank shaft is located on the opposite side of the travel trailer as the main slideout room and is labeled, “Crank Override.”
4. When the slideout is in place put pressure on the crank handle to ensure a tight seal. This will ensure that the slideout is locked into a sealed position.
5. Engage slideout locking mechanism.
6. **For Eagle and Qwest models, install “travel bars” (Fig. 3-5) in proper locations as indicated on the wall.**

CAUTION: IMPORTANT! Never store slideout without the travel bars installed on the Eagle and Qwest models. This helps seal the slideout in the closed position.

Operation (Manual Slideout – Qwest Travel Trailer)

EXTENDING ROOM

1. Release the travel lock behind the center door of the overhead cabinets located above the sofa.
2. Release second travel lock (Fig. 3-6) located below the sofa.
3. For one-person operation, push slideout into the extended position by pushing on sofa. For two-person operation, push each side of slideout until the slideout locks in place. Loud clicking of the slideout at this point is normal.

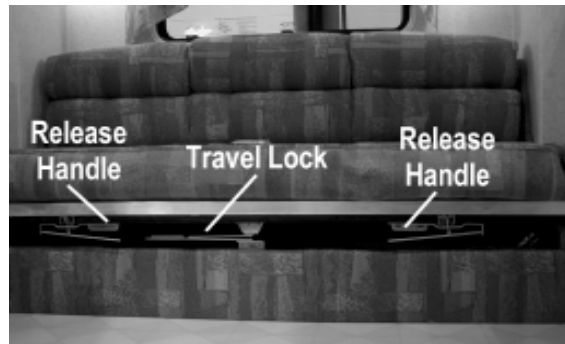

Fig. 3-6

RETRACTING ROOM

1. Lift sofa skirt.
2. Push up on release handles and pull slideout to the retracted position.
3. Lock bottom travel lock. (Fig. 3-6)
4. Lock top travel lock.

Operations (Electric Slideout)

EXTENDING ROOM

1. Batteries must be fully charged and connected. The travel trailer should be hooked up to 120-volt AC power if possible.
2. The travel trailer must be level and the stabilizer jacks in the down position.

CAUTION: Additional support jacks are not needed under the slideout. Damage can occur to your slideout room from improper use of support jacks.



Fig. 3-7

3. **For Eagle and Qwest models, remove the “travel bars” (Fig. 3-5) from behind the top facia board located above slideout room.**
4. Locate slideout room control switch.
5. To move room out, press the “OUT” button on switch (Fig. 3-7) and hold until motor stops. Release button. Travel time – approximately twenty-five seconds.

RETRACTING ROOM

1. Remove all objects left between the slideout and cabinetry.
2. Press the “IN” button to bring room in and hold until motor stops.
3. Release button.
4. **For Eagle and Qwest models, install “travel bars” (Fig. 3-5) in proper locations as indicated on the wall.**

CAUTION: IMPORTANT! Never store slideout without the travel bars installed on the Eagle and Qwest models. This helps seal the slideout in the closed position.

Troubleshooting Electric Slideout

If the slideout does not move when the slideout switch is depressed, follow these steps.

1. Check the battery for full charge and good wire connections.
2. Check for loose connections at the slideout motor.

If slideout still will not operate, follow these steps.

1. If the slideout is extended, see the section on overriding the electric slideout system.
2. If the slideout is retracted, leave it in that position. (On Eagle and Qwest models, install the “travel bars.”)
3. Take the trailer to the nearest dealer or service center.

If the slideout extends crooked, or only one side moves, follow these steps.

1. Follow steps 1 & 2 in the section on overriding the slideout system to disconnect the motor.
2. Retract slideout using the hand crank. You may need to push the side that is not sliding to get it to retract all the way.
3. Once the slideout is fully retracted, install the “travel bars” on the Eagle and Qwest models.
4. Take your travel trailer to nearest dealer or service center.

Overriding the Electric Slideout System

The Power Gear slideout system is equipped with a manual crank override that allows you to extend or retract the room if there is a loss of power.

If the system will not move when the switch is pressed, check the following:

- Is the battery connected and does it have a full charge?
- Are the travel bars removed (on the Eagle and Qwest models)?

After checking the above, follow these steps to move the slideout manually.

Tools required:

- ScruLox head screwdriver (if trailer has an underbelly)
- Crank Handle (included with unit)
- 1/2" wrench
- Adjustable Wrench (for bedroom slideout only)

SLIDEOUT OVERRIDE

Instructions for all slideouts except Fifth-Wheel Bedroom slideout.

1. If the travel trailer has an underbelly, locate and remove the access panel for the slideout motor. Refer to the drawing to locate the motor on your particular slideout. (Fig. 3-9)
2. From the rear of the motor, rotate the brake release lever on the back side of the motor counter-clockwise 1/8 turn. (Fig. 3-8) This will release the brake that locks the slideout in place.
3. The slideout is now free to move. Install the crank handle onto the crank shaft and turn it until the room is in the position you desire. The opening to insert the crank handle onto the crank shaft is located on the opposite side of the travel trailer from the slideout.
4. When the slideout is fully extended (or retracted) have one person put pressure on the crank handle to ensure a tight seal while another person returns the brake release lever on the back of the motor to its normal downward position. This will ensure that the slideout is locked into a sealed position.
5. Install the travel bars (on Eagle and Qwest models) and take the unit to a Jayco dealer for service.

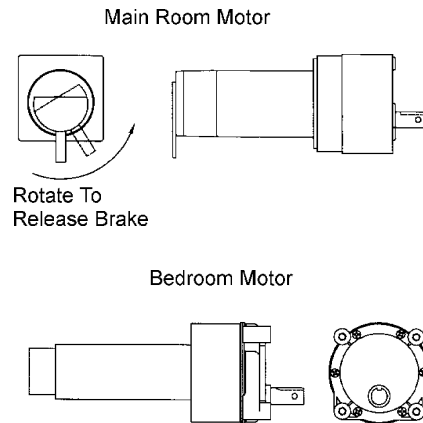

Fig. 3-8

WARNING: When the slideout motor brake is released the slideout will not lock into place, and therefore it will not be sealed from the outdoors! When the slideout has been retracted, return the brake release lever to its downward position in order to seal and lock the slideout. Install the travel bars on the Eagle and Qwest models.

BEDROOM SLIDEOUT OVERRIDE Fifth-Wheel Travel Trailer Option

1. Lift up the mattress and baseboard to gain access to the slideout unit.
2. From the rear of the motor, rotate the brake release lever on the back side of the motor counter-clockwise 1/8 turn. (Fig. 3-8) This will release the brake that locks the slideout in place.

3. Use an adjustable wrench on the square end of the drive shaft and turn the shaft until the slideout is in the position you desire. When the slideout is fully extended (or retracted), put pressure on the crank handle to ensure a tight seal then return the brake release lever to its normal downward position. This will ensure that the slideout is locked into a sealed position.
4. For Eagle models, install the travel bars and take the unit to a Jayco dealer for service.

Slideout Diagram

This diagram provides an overview of the slideout systems. Your travel trailer may contain some or all of the options listed. Slideout #3 is also the layout for a conventional travel trailer bedroom slideout, but will be located where the fifth-wheel bedroom slideout drawing is shown.

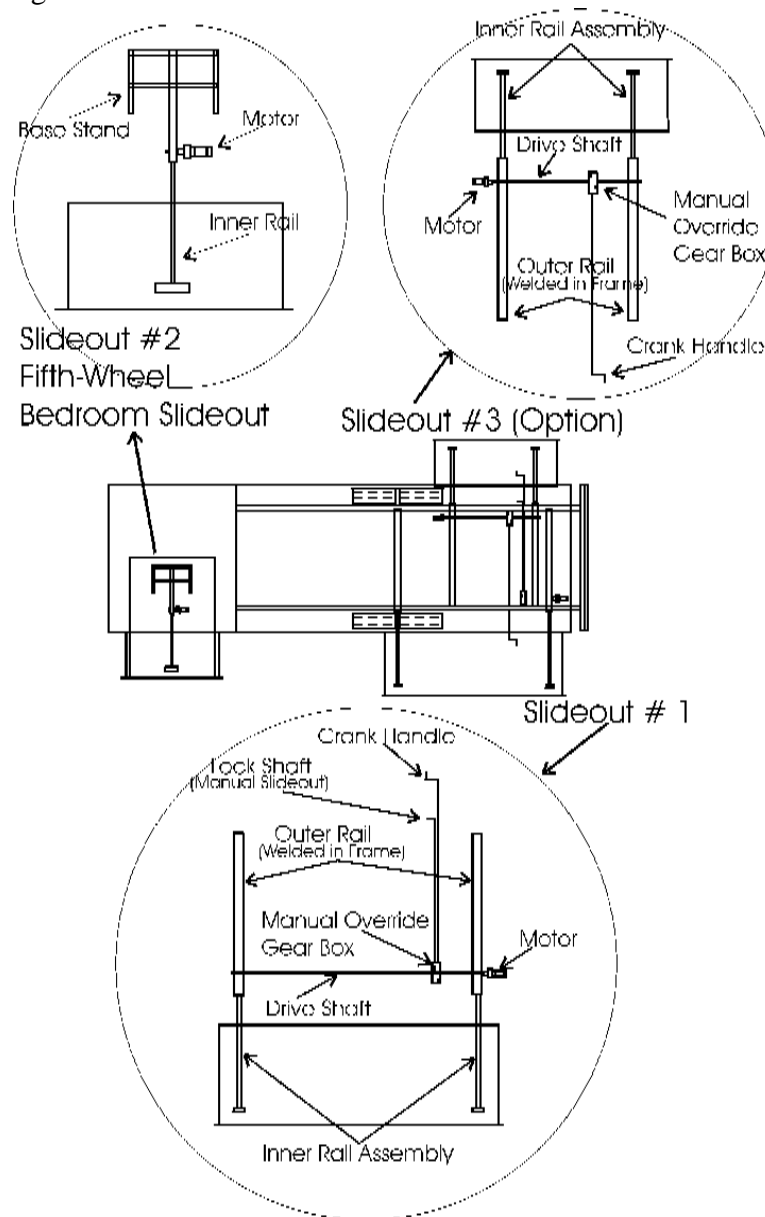
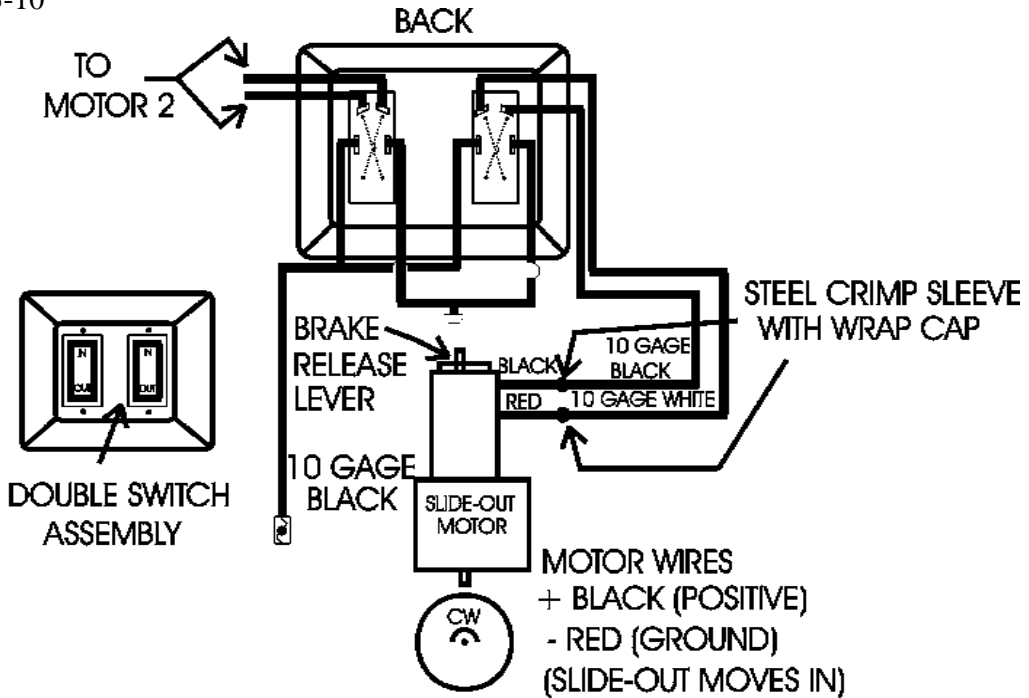
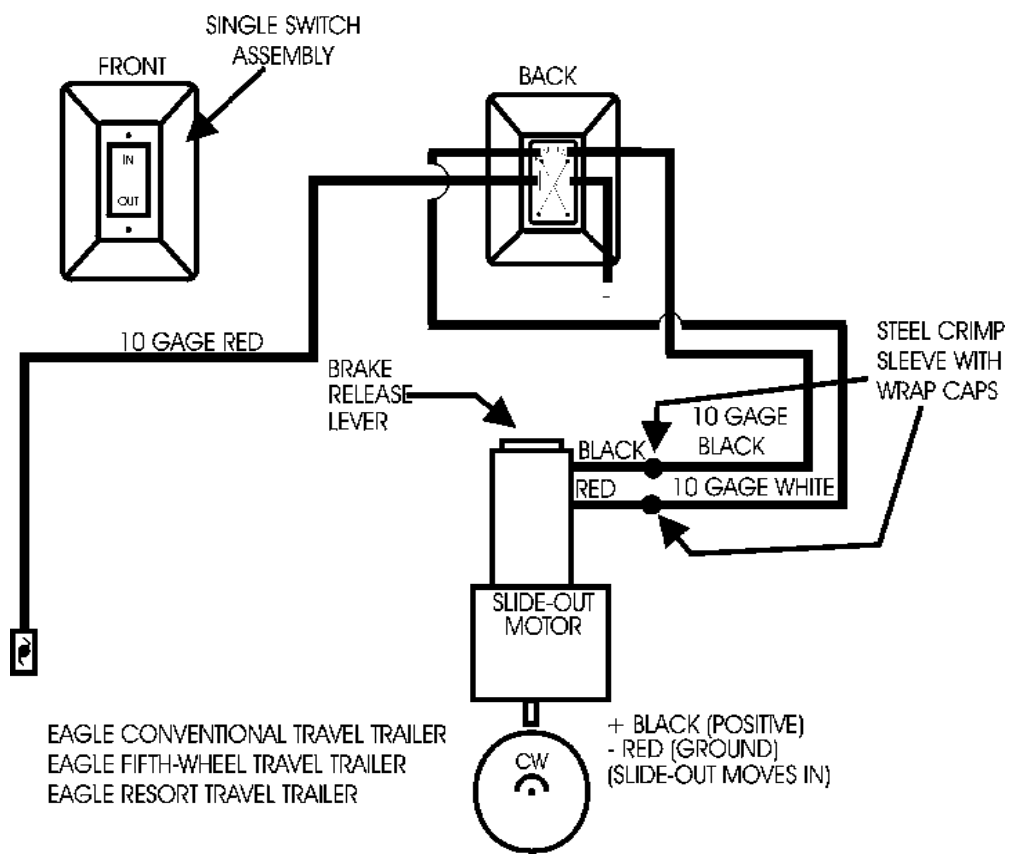

Fig. 3-9

Fig. 3-10



DESIGNER CONVENTIONAL TRAVEL TRAILER
 DESIGNER FIFTH-WHEEL TRAVEL TRAILER



EAGLE CONVENTIONAL TRAVEL TRAILER
 EAGLE FIFTH-WHEEL TRAVEL TRAILER
 EAGLE RESORT TRAVEL TRAILER

Fig. 3-11

SETTING UP YOUR TRAVEL TRAILER

Select a level or nearly level place to set up your travel trailer. There are two reasons to be level. First, all components in your travel trailer are designed to operate in a level position, such as your water drainage system and especially your refrigerator. Second, it is more comfortable. Should a level site not be available, use short 2" x 6" blocks of wood to raise the low side wheels to a level position.

Before unhooking the travel trailer from tow vehicle, always mount the dolly wheel to tongue jack and block the travel trailer wheels to keep the travel trailer from rolling away.

1. Release weight distributing bars (if used).
2. Release safety latch on coupler.
3. Raise coupler on A-Frame by turning tongue jack until ball is free.
4. Disconnect seven (7) way wire connector, safety chains, and breakaway cable.
5. Move tow vehicle away as desired.
6. Lower or raise tongue jack until travel trailer is level.
7. Lower stabilizer jacks by placing the crank onto the jack shaft and turning clockwise to lower it until the frame of the travel trailer begins to rise slightly. Equalize all four jacks for best support. You may need to adjust each jack two or three times. For convenience when you are not parked on cement, you may wish to place a wood or hard plastic block under the jack.

CAUTION: DO NOT USE THE STABILIZER JACKS TO LEVEL THE UNIT. It is important to remember that stabilizer jacks are to be used only for support while occupying and moving around in your travel trailer. They are not designed to bear the weight of the travel trailer.

Upon completing the setup of your travel trailer, you are now ready to make attachments to various facilities as listed:

- Waste water hose connections
- 120-Volt power cord electrical hookup
- Turn on LP propane tanks and light pilot lights on any appliances. Remember there may be air in your LP propane lines. Be sure to bleed them before planned usage.
- Open any windows and roof vents as desired for ventilation.

You may have additional accessories and options such as an awning on the door side which need to be opened. Separate instructions are provided by the manufacturer of the component.

See the process to follow before departing from your campsite under the hitching procedures listed earlier in this chapter.

CARBON MONOXIDE DETECTOR (Option)

Fifth-Wheel Travel Trailers Only

If your towable RV has a generator or generator prep, a carbon monoxide detector will be installed on your unit.

Carbon monoxide (CO) is an odorless, colorless, tasteless gas that is extremely dangerous to humans and animals. The following symptoms are indicative of individuals exposed to carbon monoxide:

Mild Exposure: Slight headache, nausea, vomiting, fatigue

Medium Exposure: Severe headache, drowsiness, confusion, fast heart rate

Extreme Exposure: Unconsciousness, convulsions, cardiorespiratory failure, death

A UL listed carbon monoxide detector has been installed in your camper. It is designed to detect toxic CO fumes. It is not a substitute for other combustible gas, fire or smoke alarms.

Procedures to Take During an Alarm

WARNING: The activation of the CO detector is a warning that indicates the presence of carbon monoxide!

WARNING: Do not disconnect the CO detector to silence the alarm. The detector is designed to sense when the level of CO in the air falls below the danger level. All individuals should remain outside the unit until the alarm is silent.

- If someone is suffering from an upset stomach, headache or other symptom, immediately move to a location that has fresh air. Ensure that everyone is accounted for, including pets. Call the Fire Department. Do not reenter the unit until the source of carbon monoxide has been located and repaired by a qualified technician.

WARNING: Low levels of CO have been linked to brain and vital organ damage to unborn infants with no effect on the mother. Pregnant women should leave the unit immediately if an alarm is sounded and not return until the unit has been repaired and aired out thoroughly.

- If no one exhibits the symptoms associated with carbon monoxide:
 1. Push reset button.
 2. Turn off all sources of combustion including water heater, furnace, stove, oven, and automobile.
 3. Open windows and doors and move to a location that has fresh air.
 4. Call a qualified technician and have the problem corrected before restarting appliances and/or vehicles.

Maintenance/Testing

See “Maintenance and Testing” instructions in Chapter 7. Additional information is supplied in the manual published by the manufacturer of the equipment.

TV ANTENNA

Raising Antenna to Operating Position

Turn the elevating crank clockwise in the UP direction about thirteen turns or until some resistance to turning is noted. (Fig. 3-12)

On Amplified models, 12-Volt DC power is required. Turn the power supply ON to use either the front or rear TV outlet. (Fig. 3-13) Neither outlet will work unless the power supply switch is on. Turning the power supply on sends 12-volt DC through the cable to the antenna. The voltage energizes the transistors on the amplifier in the antenna head. The TV signal comes back down the cable to the outlets.

After the antenna is in the full UP position, pull down on the round knob with both hands until it disengages from the ceiling plate. Rotate the knob for best picture. (Fig. 3-14)

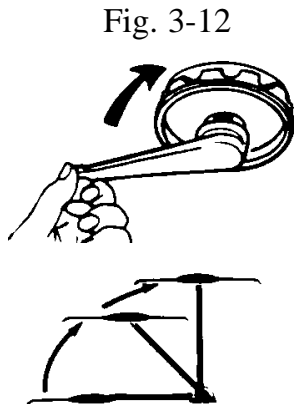

WARNING: DO NOT connect high current devices such as hair dryers to this receptacle. Maximum current rating of this receptacle is 7.5 amps at 12-volt DC.

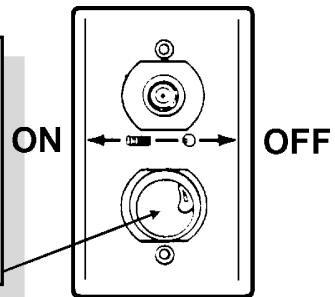
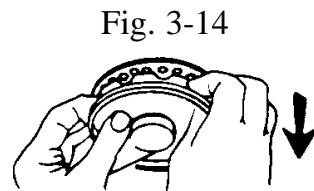

Fig. 3-13

To Test System

1. Make sure the TV set is working properly.
2. Switch the power supply ON and OFF to see if there is a difference in the picture quality while watching TV. If there is NO difference, refer to manufacturer's manual for further testing procedures.



CAUTION: The power supply should be turned OFF when connecting/disconnecting the cables to the power supply and antenna, but should be turned ON when testing for voltage.

Lowering Antenna to Travel Position

Rotate the antenna until the pointer on the directional handle aligns with the pointer on the ceiling plate. Turn the elevating crank counterclockwise in the DOWN direction about thirteen turns or until resistance is noted. The antenna is now locked in the travel position. (Fig. 3-15)

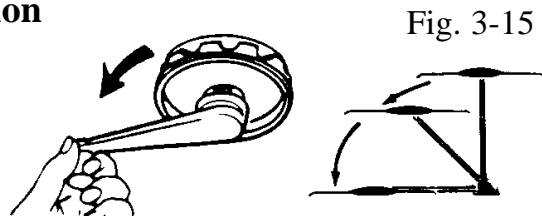

CAUTION: When lowering the antenna, never lower it into any position except the TRAVEL POSITION. Failure to lower antenna into the TRAVEL POSITION before traveling may damage the antenna and is not covered by warranty.

Maintenance

See "TV Antenna Maintenance" in Chapter 7.

CHAPTER 4 THE SYSTEMS

PLUMBING SYSTEM

Included in your Jayco recreation vehicle is a complete fresh water system. Fresh water may be obtained through two sources: city water connection or gravity fill tank. Each component is explained along with its operation.

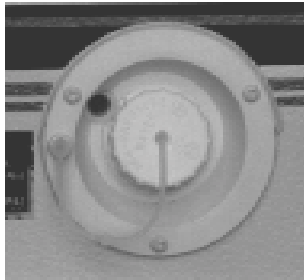

Fig. 4-1

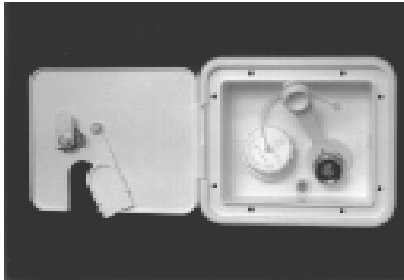

Fig. 4-2



Fig. 4-3

City Water Connection

Water may be received into the system through a direct hookup referred to as the city water connection. (Fig. 4-2 or 4-3) After hooking up water hose to travel trailer, open valve on supply line. Enter coach and open faucets to bleed air from lines. Water will fill water heater first before supplying lines and faucets. When lines are almost full, you may experience some air pockets. Allow them to escape before closing faucets.

CAUTION: Excessive pressure from water supply systems may be encountered in some parks, especially in mountain regions. Water pressure regulators are available to protect your system against such high pressure. A regulator of this type is recommended to prevent damage to plumbing systems or components. Not using a water pressure regulator when using city water may cause the o-rings to blow. It is advisable to always use a water pressure regulator when using the city water connection.

Water Tank – Gravity Fill

A water container is permanently installed in your recreation vehicle. On some models it is located inside the travel trailer under a bed, dinette, or sofa. Other models may have an external tank under the floor between frame members. To fill the tank, there are two types of gravity fill connections to the fresh water tank. Fig. 4-1 is the type found on most models. Fig. 4-2 has a combination of gravity fill and city water connection enclosed which requires a key to gain access.

The fresh water tank can be filled by removing the gravity fill cap and inserting a garden hose. Open faucet from water supply and fill tank. You must be careful not to over fill tank. This can pressurize the tank, causing leakage and water damage.

CAUTION: DO NOT leave tank unattended while filling.

12 Volt DC Demand Pump

When water is desired and you are not hooked up to city water, you need to turn on 12 volt DC power to start the demand pump. Fig. 4-4 shows a typical demand pump set up. Depending on your travel trailer model, the demand pump will be located under the bed, in a cupboard, or under the sink. The switch to operate the pump (Fig. 4-5) is located on the monitor panel or a wall near the pump. Energy for the pump is supplied by the auxiliary battery or converter. The pump will self prime when started and provide water for your travel trailer. The pump continues to run until approximately forty pounds of pressure is achieved and automatically starts again when pressure drops to twenty pounds. Some cycling in the pump may occur, depending on the volume of water being released. A check valve is built inside of the pump to prevent water from flowing into supply tank.

Note: The water pump switch should be in the off position when the camper is left unattended for any amount of time. If something would happen to the water system, this will ensure that water damage will be restricted to a small area.



Fig. 4-4

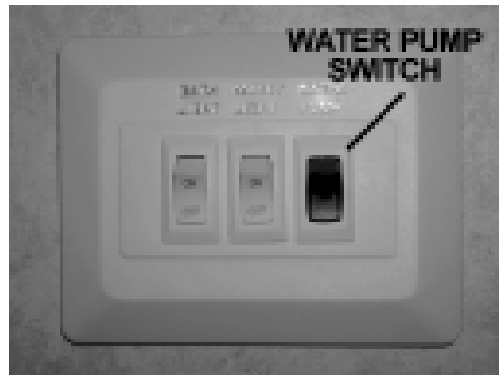

Fig. 4-5

Sanitizing and Filling the Potable Water System

Potable water systems require periodic maintenance to deliver a consistent flow of fresh water. Depending on use and the environment the system is subject to, sanitizing is recommended prior to storing and before using the water system after a period of storage. Systems with new components, or ones that have been subjected to contamination, should also be disinfected as follows:

1. Use one of the following methods to determine the amount of common household bleach needed to sanitize the tank.
 - Multiply “gallons of tank capacity” by 0.13; the result is the ounces of bleach needed to sanitize the tank.
 - Multiply “liters of tank capacity” by 1.0; the result is the milliliters of bleach needed to sanitize the tank.
2. Mix the proper amount of bleach into a container of water.

3. Pour the solution (water/bleach) into the tank and fill the tank with potable water.
4. Open **all** faucets (Hot and Cold) allowing the water to run until the distinct odor of chlorine is detected.
5. The standard solution must have four (4) hours of contact time to disinfect completely. Doubling the solution concentration allows for contact time of one (1) hour.
6. When the contact time is completed, drain the tank. Refill with potable water and purge the plumbing of all sanitizing solution.

NOTE: The sanitizing procedure outlined above is in conformance with the approved procedures of RVIA ANSI A119.2 and the U.S. Public Health Service.

If there is a problem of excessive chlorine odor and taste after the sanitizing process, follow the above procedures using a solution of baking soda (1/2 cup added to one gallon (4 liters) of water per 15 gallons (60 liters) of tank capacity) or vinegar (one quart added to five gallons (20 liters) of water per 15 gallons (60 liters) of tank capacity.)

Your demand water system is now ready for use.

Definition of the Utility Center Label Terms (Fig. 4-6)

Normal – This setting allows you to pump water from the fresh water tank to all faucets when you are not hooked up to city water. Turn on your 12-volt demand pump to accomplish this.

City Water – This setting allows you to have access to water at all faucets on demand. Connect a garden hose from an outside water source to the city water connection inlet at the utility center and turn on your outside water.

City Tank Fill – This setting allows you to fill your fresh water tank. Connect a garden hose from an outside water source to the city water connection inlet at the utility center. Open the faucets inside the trailer to bleed air from the lines, and turn on your outside water.

Country Tank Fill – This setting allows you to fill your fresh water tank with water from an outside tank. Connect a garden hose to the city water connection at the utility center; put the other end of the hose in the outside water tank, and turn on your 12-volt demand pump.

Sanitize Tank – (See the instructions in the following section.)

Antifreeze/Sanitize Lines – (See the instructions in the “Winterizing Units with Utility Centers” in this manual.)

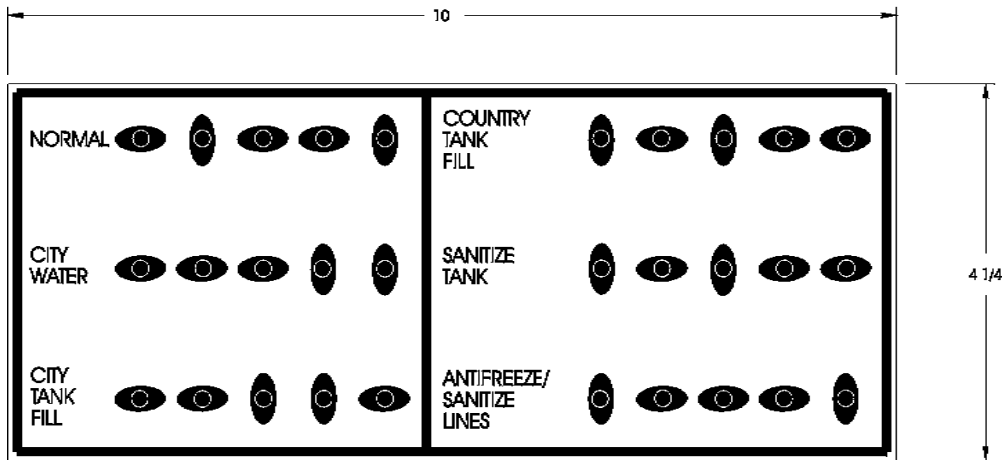

Fig. 4-6

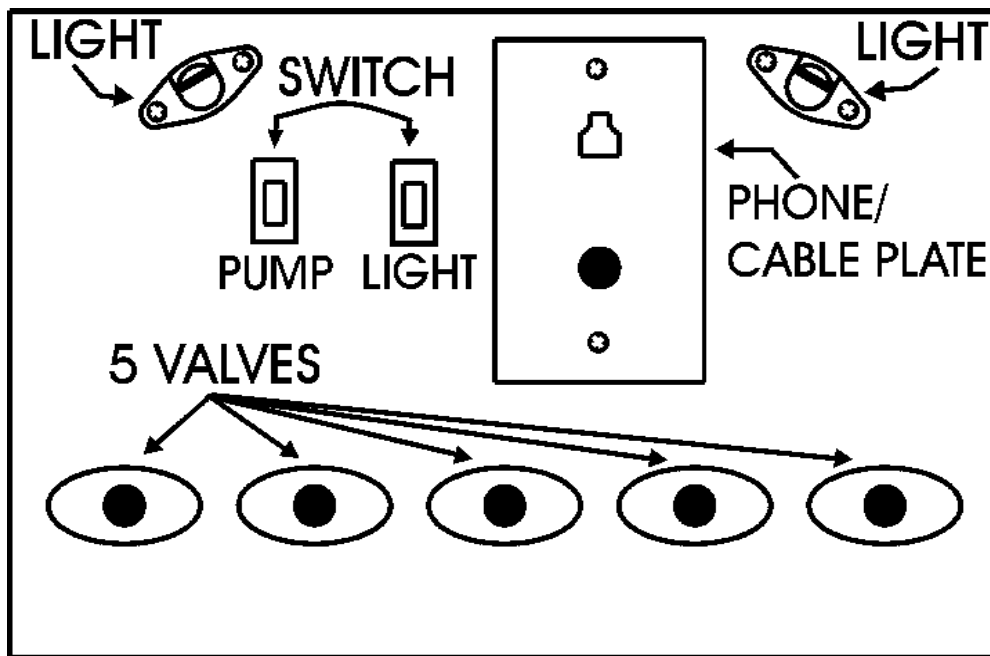

Fig. 4-7

Sanitizing Units with Utility Center

1. Drain the water tank and water heater completely by opening all faucets and low point drains until tank and heater are empty.
2. In a large bucket prepare a chlorine solution using 3/4 cup of household bleach and three (3) gallons (12 liters) of water.
3. Attach the intake hose to the "City Fill Connection" located under the utility center panel. (Fig. 4-8) Place the free end in the bucket of chlorine solution.
4. Position the "Control Valves" on the "Utility Panel" to the "Sanitize Tank" configuration. (Fig. 4-6)
5. Turn the "Water Pump Switch (Fig. 4-7) to the "ON" position and pump all of the chlorine solution into the tank.

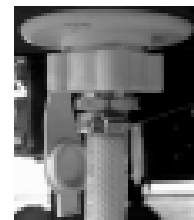

Fig. 4-8

6. After pumping all the chlorine solution into the tank, position the “Control Valves” to the “City Fill” configuration. (Fig. 4-6)
7. Attach a garden hose to the “City Fill Connection” (Fig. 4-8) and finish filling the tank.
8. Open kitchen and bathroom faucets to allow air to escape the water lines and the water heater.
9. Turn the “Water Pump Switch” to the “ON” position and allow several seconds for the pump to prime. (Fig. 4-7)
10. After the water heater and water lines fill, the air will stop bubbling out of the faucets. At this point, turn all faucets off. Please note, the water heater will hold approximately six gallons of water. Allow the water to run long enough to ensure that the tank is full.
11. Allow to stand for three hours.
12. Drain the water tank and water heater completely by turning on all faucets until the tank and water heater are empty.
13. With the garden hose connected to the “City Fill Connection” (Fig. 4-8), refill the tank with fresh water as in steps 6 and 7.
14. Open kitchen and bathroom faucets to allow air to escape the water lines and the water heater.
15. Turn the “Water Pump Switch” (Fig. 4-7) to the “ON” position and allow several seconds for the pump to prime.
16. After the water heater and water lines fill, the air will stop bubbling out of the faucets. At this point, turn all faucets off. Please note, the water heater will hold approximately six gallons of water. Allow the water to run long enough to ensure that the tank is full.
17. Allow to stand for at least three hours.
18. Drain the water tank and water heater completely by opening all faucets and low point drains until tank and heater are empty.

To remove excess chlorine odor and taste:

1. In a large bucket, prepare a solution of 1/2 cup baking soda to one gallon (4 liters) of water for every 15 gallons (60 liters) of tank capacity.
Repeat steps 3-10 from above.
2. Allow the baking soda solution to sit in the tank for a few days, if possible. If you can have the soda in the tank while traveling, it will work better to clean and refresh the tank from the agitating motion.
Repeat steps 12-18 from above.
3. Drain the water tank and water heater completely by turning all faucets on until the tank and heater are empty.

Faucets

Bathroom or kitchen faucets operate the same as in your home. Open by turning knobs. There may be air in lines which needs to be bled out. Close faucets when sufficient water is released.



Fig. 4-9

Bath and Shower

Your bathroom facilities function similar to those in your home. Prepare bath or shower curtains to prevent water from spilling onto floor. Ensure water heater is in operation before bathing. Adjust the faucets for desired temperature before entering tub or shower.

Used water will drain through plumbing pipes into gray water holding tank. Remember there are limited capacities in the water heater and gray water holding tank. Long showers in a recreation vehicle are NOT suggested due to the amount of water that is available.

Any tub or shower faucet requires a vacuum breaker when a shower hose and head is used. There are two purposes for this breaker; first to prevent siphoning water through the hose from another fixture, and secondly to prevent water from being contained in the hose. The shower head also DOES NOT have a complete shut-off valve. Any drainage from either part is normal function and NOT a leak. The complete shut-off is at the faucet.

Outside Shower (Option)

A convenient faucet assembly with hot and cold water is available for exterior use washing and rinsing on the outside of the camper.

OPERATION

1. Activate pump.
2. Open door with key and allow to hinge down.
3. Remove shower head and open valve.
4. Open faucet valves and adjust to temperature as desired.
5. To cease operation, close valve(s) on faucet and allow water to drain from shower head.
6. Close valve on shower head.

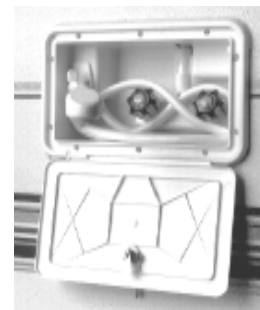

Fig. 4-10

Any water remaining in the hose will drip or run out of vacuum breaker. This is NOT a leak, but performs as intended. Water in A.B.S. plastic box will drain out along outer edge. The shower head can be removed to drain the hose faster. Reassemble and place onto bracket. Keep the door closed when not in use for sanitary reasons.

Drainage

All permanent fresh water tanks can be drained by one of two types of drain valve:

1. A white plastic drain is attached to outer wall. Open valve and allow to drain. (Fig. 4-11)
2. A valve is located inside of coach adjacent to the water tank. The knob turns 45° to open and close.



Fig. 4-11

To drain the water supply lines, locate the “low-point” drains as shown in Fig. 4-12. These valves are placed near the floor and may be located under cabinets, dinettes, sofas, beds, or in storage areas. As their name indicates, they will be at the lowest point of water lines. A label is placed on the outside of the travel trailer to indicate where the drains are located. The drains will typically need to be opened from inside the trailer. Once the label is found on the outside of the trailer, go inside to find the corresponding location of the drains.

TO DRAIN SYSTEM:

1. Open all faucets including optional exterior shower.
2. Open fresh water tank drain.
3. Open water heater drain. (Consult water heater owner’s manual for details.)
4. Open all (2 to 4 depending on the model of your unit) low-point drains.
5. Open toilet valve, hold or block if need be.
6. To empty pump, start and allow to run 15-20 seconds.



Fig. 4-12

SANITATION SYSTEM (Marine Toilets Only)

Toilets

Two types or models of toilets are used on Jayco campers. One is the Aqua Magic® Starlight/Galaxy/Aurora model featuring two foot pedals for flushing. The second type, the Aqua Magic® 4, features two levers on the back side to flush the toilet.

OPERATING INSTRUCTIONS – STARLIGHT/GALAXY/AURORA

Your toilet is efficient and easy to operate. Prior to utilizing the unit or after dumping your holding tank, add the proper amount of deodorant to tank. Adding a deodorant will help control waste odors in the tank. After each use, the bowl fills with water automatically to a depth of two inches (50 mm). To add additional water to bowl, step on the small pedal and hold until the desired amount of water is in the bowl. Release



Fig. 4-14

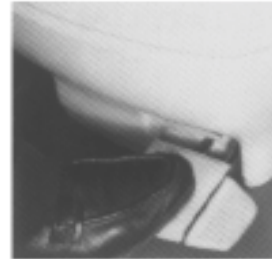
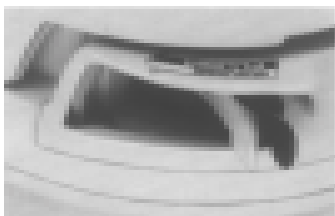

Fig. 4-15

pedal slowly (Fig. 4-14). To flush, step on the large pedal until rinse clears the toilet bowl, release pedal slowly (Fig. 4-15). **YOU MUST USE AN ADEQUATE AMOUNT OF WATER WHEN FLUSHING TO PREVENT SOLID WASTE BUILD UP AND PROMOTE PROPER DRAINAGE.** See Holding Tanks.

OPERATING INSTRUCTIONS – AQUA MAGIC® 4

The Aqua Magic® 4 is equipped with two operating levers located on the right side of the toilet when facing the unit. To flush, pull the black lever (Fig. 4-18) forward (clockwise) until rinse clears bowl and release lever slowly. Movement of the flush lever opens the waste valve and allows waste to pass into the holding tank. Water fill is activated simultaneously with the black flush lever. The lever should be held open for several seconds to allow adequate flush water coverage of bowl to develop. The white water fill lever (Fig. 4-17) can be operated independently of the black flush lever if more than the normal two inch (50 mm) automatic bowl refill water is desired. **YOU MUST USE AN ADEQUATE AMOUNT OF WATER WHEN FLUSHING TO PREVENT SOLID WASTE BUILD UP AND PROMOTE PROPER DRAINAGE.** See Holding Tanks.



Flushing lever (black) and water fill lever (white) shown in the normal closed position. Fig. 4-16



Pull water fill lever (white) to adjust to desired level. Fig. 4-17

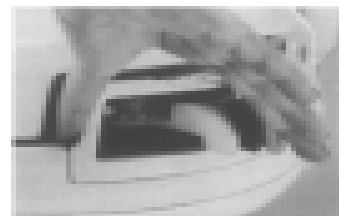

Single forward motion flushes and refills bowl. Fig. 4-18

Maintenance

See “Toilets” section under maintenance in Chapter 7.

Residential Stools (Resort Model Only)

Prior to transit, remove tank lid and place in safe location. Flush toilet to empty tank.

Using Toilet and Tank System

Note: For added convenience and better sanitation system performance, it is advisable to always have four to six inches (10-15 cm) of water in the toilet.

Prior to using the sanitation system, it is strongly recommended to flush the toilet several times and release sufficient water into the tank. If there is not a sufficient amount of water used during flushing, waste materials may not evacuate properly from the drain line to the tank. Clogged tanks and pipes could eventually occur.

When camping you should always have four to six inches (10-15 cm) of water in the toilet bowl. The toilet system will perform better when water is run for ten to fifteen seconds after flushing to ensure waste will proceed to the bottom of the tank. Unlike your toilet at home which uses four to seven gallons (18-32 liters) of water per flush, the average recreation vehicle system uses one to three quarts (1-3 liters).

When hooking up to the sewer drain line at a campground, keep the termination valve on the waste tank **CLOSED** until the tank is at least 3/4 full. This will provide sufficient water to assist in complete draining of the tank. At this time, open the termination valve to empty the tank and close the valve when the tank is empty. Repeat this process as needed, but **NEVER** leave the termination valve open when hooked up to the park's sewer system.

Vents

Another important part of the sanitation system are the vents which release air from tanks. Each tank has a vent pipe built into the travel trailer through the cabinet, wall and roof. A vent cap is attached to the roof and must be clear of obstructions to perform as intended. On some models the vent pipe may be part of the drainage system referred to as a "wet vent." This means water flows downward as air flows upward in the same pipe.

Holding Tanks

The final part of your system are the holding tanks. They hold waste and are located below the floor of your coach. Bath tub and sinks drain into the waste water tank, also referred to as the "gray" water holding tank. The toilet drains into the sewage holding tank, also referred to as the waste holding tank. Certain floor plans may also have the lavatory draining into the waste (sewage) tank.

SEWAGE TANK PREPARATION

1. Release one to two quarts (1 or 2 liters) of water into the toilet bowl.
2. Following the directions on your toilet chemical bottle by placing the recommended quantity of holding tank chemical into the bowl.
3. Flush the toilet and allow at least two gallons (8 liters) of water to flow into the tank.

| |
|--|
| <p>CAUTION: It is important to add enough water to prevent solid waste build up. Follow these directions each time after emptying your holding tank, except when winterizing.</p> |
|--|

GRAY WATER HOLDING TANK

No special preparation is required. However, placing a small quantity of chemicals into this tank, such as baking soda or a Thetford chemical, will reduce odors from food particles in the system.

WARNING: We recommend that you DO NOT travel with waste in your holding tanks. Full holding tanks are not calculated into the cargo carrying capacity of the unit and the extra weight will greatly diminish the cargo weight available to you, possibly causing you to exceed the gross vehicle weight rating of the unit. This can damage suspension components, such as springs, tires and axles. If your model has the holding tanks located behind the axles, the weight of a full tank will reduce the hitch weight. Sway and other handling difficulties can be the result of the hitch weight being too light. If you are dry camping and cannot immediately empty the tanks, use caution when towing and maintain lower speeds for better control of the trailer until you reach a dumping station.

DRAINING THE TANKS

On the outside of the trailer are labels (Fig. 4-19 & 4-20) that indicate the location of the gray and black holding tank drain. A typical set up of the tank drain and termination valves is indicated in Fig. 4-21. Look for the labels to locate the drain and follow the instructions below to empty the tanks.



Fig. 4-19



Fig. 4-20



Fig. 4-21

When hooking up to the sewer drain line in a campground, keep the termination valve on the waste tank **CLOSED** until tank is at least 3/4 full. This will provide sufficient water to assist in complete draining of tank. At this time, open the termination valve to empty the tank (see directions for draining below) and close the valve when the tank is empty. Repeat this process as needed, but **NEVER** leave the termination valve open when hooked up to the park's sewer system.

To empty tank:

1. Place travel trailer as level as possible to make drainage easier.
2. Attach a flexible sewer hose to adapter and secure with a clamp.
3. Remove cap and attach adapter onto valve housing.
4. Turn adapter 10° to lock onto pegs.
5. Place other end into approved sewer system.
6. Open the 3" drain valve to drain the sewage tank.
7. Open the valve on the gray water tank to utilize the water to wash and rinse the hose.

All drain pipes have a "P-trap" installed into each line. Water in these traps prevent odors from escaping into the travel trailer. During travel, water from the P-traps may spill and permit odors into travel trailer. These odors come from food particles decomposing in the tank. By adding water and using a RV approved deodorizing agent the contents will dissolve faster and will keep the drain lines and tanks clean and free flowing. Chemicals are available at an RV supply store.

Most states and parks have strict laws and regulations to prohibit dumping of wastes of any kind into anything other than proper disposal facilities or sewer systems. Almost all privately owned parks have either a central pump facility or offer a campsite hookup of sewage. You can find lists of many dump facilities throughout the United States in *Woodall's*, *Rand McNally Camp Guide*, *Good Sam Camp Guide*, *KOA Campgrounds Camp Guide*, and various other publications. Some fuel stations also have dump stations.

WINTERIZING TRAVEL TRAILER

Preparing your recreation vehicle for winter is very important for most states and Canada. Failure to prepare the coach will cause supply lines and water heater to freeze causing breakage. Repairs due to freezing are not to be covered under the terms of your Jayco Limited Warranty.

Please keep in mind that your towable RV was not designed for use during sub-freezing weather.

There is no commodity or product that can be added to the fresh water systems to ensure freeze protection while the system is in use, other than RV antifreeze. Do not drink water that contains antifreeze. This includes non-toxic RV antifreeze.

WARNING: Do not use Ethylene Glycol (automotive antifreeze) or Methanol (windshield washer antifreeze) in your fresh water system. They are harmful and may be fatal if swallowed.

Two methods of winterizing your travel trailer after draining and flushing your drainage system are listed below.

Method 1

1. Make sure all holding tanks are empty.
2. Run the pump until dry, about 15-20 seconds.
3. Using an air hose and adapter, blow air through the city water connection.
4. Leave the faucets, drains and toilets open. Any remaining water will blow out in five to ten minutes.
5. Pour one cup of NON-TOXIC RV antifreeze into all drain P-traps.

Method 2

This method utilizes a water heater bypass kit, available in most units, to avoid filling the entire water heater with antifreeze.

1. Make sure all holding tanks are empty.
2. Turn off the pump.
3. Close valves A, B and D. Open valves E and C. (Fig. 4-13)
4. Drain the water heater and fresh water tank. (Consult the water heater owner's manual for details.)
5. Put the hose from valve E into a jug of **NON-TOXIC** RV antifreeze. You will need more than one gallon of antifreeze.
6. Turn on the pump and open each faucet until the antifreeze flows through. Do not forget to run the antifreeze through the toilet.
7. Pour at least one cup of antifreeze into each drain to protect the P-traps.
8. Close valve E.
9. Before using the water system again, drain and flush the water system. Close valve C and open valves D, A, and B. Sanitize and flush the whole system. It is now ready for use.

To winterize: Valves A, B, and D are closed; E and C are open.

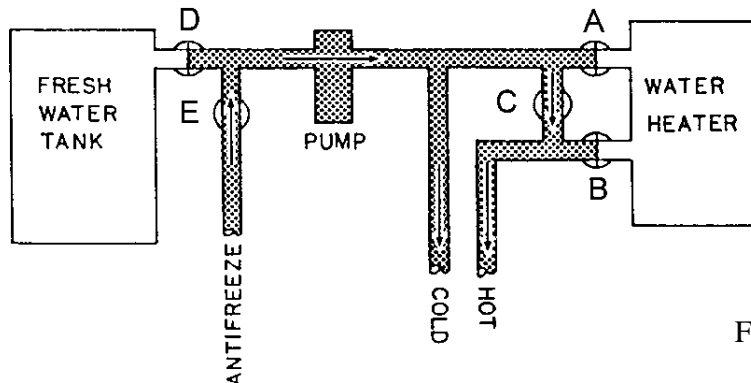

Figure 4-13

Winterizing Units with Utility Center

1. Drain the water tank and water heater completely by opening all faucets and low point drains until the tank and water heater are empty. Make sure all holding tanks are empty.
2. Position the "Control Valves" on the "Utility Panel" to the "Antifreeze/Sanitize Lines" configuration. (Fig. 4-6)
3. Attach the intake hose to the "City Water Connection." (Fig. 4-8)

WARNING: Do not use Ethylene Glycol (automobile antifreeze) or methanol (windshield washer fluid) in your fresh water system. They are harmful and can be fatal if swallowed.

4. Put the free end of the hose into a jug of NON-TOXIC RV Antifreeze. You will need more than one gallon of antifreeze.
5. Turn the "Water Pump Switch" (Fig. 4-7) to the "ON" position and open each faucet until the antifreeze flows through. Do not forget to run the antifreeze through the toilet.
6. Pour at least one cup of antifreeze into each drain to protect the p-traps.
7. Before using the water system again, open the valves A, B, and C, then sanitize and flush the whole system. (See instructions under "Sanitizing – Units with Utility Centers.)

LP FUEL SYSTEM

It is because of the LP gas system that your RV has the convenience of a refrigerator, stove, water-heater, and furnace. This system has containers that contain the fuel and also regulators to control the pressure of the fuel and supplies the gas vapor to the various appliances. When correctly used, the LP system is very effective and will ensure the comfort and added convenience for your vehicle. This system is also potentially very dangerous and should be used with care.

Liquefied petroleum (LP) is a product that is refined from crude oil through natural gases. Propane is a colorless and odorless gas that in the liquefied state resembles water. An odorant is added as a warning agent. This is usually a sulfur compound which gives the gas the rotten egg, stinky, skunk oil odor. It is extremely important to become familiar with the odor associated with LP gas.

LP fuel is stored in a pressurized canister in a liquid state. As the fuel is released from the canister, it becomes vapor that is needed for the operation of the appliances. In the liquid state, propane should not run through the appliances. A liquid fuel will damage the o-rings in the valves and also leave a sticky, oily residue causing poor or no operation in the regulator.

LP Container

The tank or bottle is a D.O.T. approved container to hold fuel in liquid form, and is normally a 20# or 30# (44 or 66 kilograms) capacity. The open/close valve is to be closed at all times unless hooked up to LP gas system or filling container. When the container is disconnected from the hose and P.O.L. connection, install P.O.L. plastic plug that is attached to container. This is required by RV industry, Gas Association, and for your own safety. Do not allow the container (filled or empty) to move or roll around while transporting to and from filling location.

WARNING: Because your vehicle has exterior combustion air inlets, all appliance pilot lights should be turned off during gasoline or propane refueling. Laws in some states require this.

Servicing and Filling LP Containers

Filling an LP container correctly is very important and should be performed by a qualified person who knows the proper inspection and safety procedures. Any new container must be carefully purged for best performance and must NEVER BE OVER-FILLED.

CAUTION: DO NOT use tools to open or close tank valve. HAND TIGHTEN ONLY.

CAUTION: Never smoke during the filling of LP tanks. Keep the RV away from immediate filling area when possible or extinguish all gas pilot lights.

LP gas expands 1½% for each 10° increase in temperature. It is imperative to leave sufficient space inside the container to allow for the natural expansion of gas during warmer weather. Each propane container is equipped with an overfill device built into the main valve. This device must remain open during the filling. When the container is filled

to 80%, the maximum level for safety, a liquid will appear replacing the vapor. Stop filling immediately and close both valves; **HAND TIGHTEN ONLY.**

WARNING: A propane container should never be filled beyond 80% of its capacity.

If your tank becomes overfilled and is not allowed to “bleed off” before installation to the RV system, it may gain pressure from exposure to direct sunlight and will begin “blowing off” pressure from the overflow valve. This will be detected by the strong odor around the tanks. Keep open flames away from this area. It is best to find a technician qualified in releasing an overfill from the container. If that is not possible, remove the bottle, take it to a safe area at least twenty-five feet (10 meters) from any source of combustion, and “bleed off” the excess pressure by opening the valve slightly and closing it when discharge has been sufficient, one to two minutes.

WARNING: LP gas containers are equipped with safety devices which relieve excess pressure by discharging gas into the atmosphere. Do not bring or store LP gas containers, gasoline or other flammable liquids inside the recreation vehicle. Disregarding this warning may result in fires or explosions.

When an LP tank gets low, sometimes there is a concentration of garlic-like odor which may be mistaken for a gas leak. After a change over to a full tank, the odor usually will disappear. If not, turn off the LP containers and have the system checked by a qualified technician.

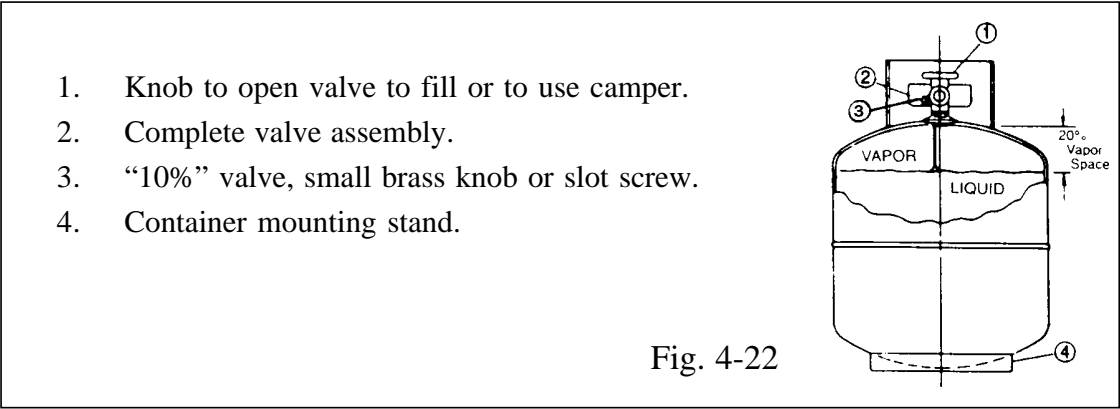

1. Knob to open valve to fill or to use camper.
2. Complete valve assembly.
3. “10%” valve, small brass knob or slot screw.
4. Container mounting stand.

Fig. 4-22

A warning label has been located near the LP gas container. This label reads:

THIS GAS PIPING SYSTEM IS DESIGNED FOR USE OF LIQUEFIED PETROLEUM GAS ONLY. DO NOT CONNECT NATURAL GAS TO THIS SYSTEM. DO NOT FILL CONTAINER(S) TO MORE THAN 80 PERCENT OF CAPACITY. Securely cap inlet(s) when not connected for use. After turning on gas, except after normal container replacement, test gas piping and connections to appliances for leakage with soapy water or bubble solution. Do not use products that contain ammonia or chlorine.

AD-34

OPD Overfill Protection

Supplied with your travel trailer is information that applies to the Type 1 ACME LP Gas Connection on your LP gas tank(s). Please read all information contained in the supplied literature.

The following instructions will supply information for correct cylinder/valve orientation, regulator placement, hose length, hose routing and cylinder cover placement. Make sure these steps are followed for proper LP connections.

DUAL CYLINDER ASSEMBLY WITH BOTTLE RACK ON A-FRAME OR FRONT TRUNK

1. Connect the 3/8" low-pressure hose to the outlet of the two-stage regulator.
2. Place the cylinders on the bracket provided on the A-frame and secure them so the outlet of the cylinder valves point outward from the front of the travel trailer.
3. Using the threaded center rod, position the regulator bracket. This centers the regulator between the two cylinders as they are secured to the base tray.
4. Attach the inverted flare x 11" Type-1 pigtail hose to the regulator inlet and the right hand swivel nut to the cylinder valve.

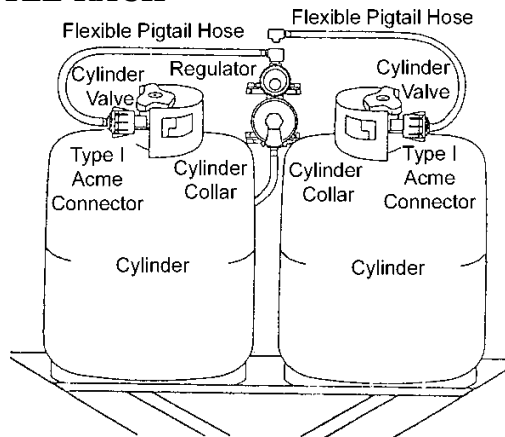

WARNING: The pigtail hose must be installed to avoid tension or pulling stress at either end of the hose.

WARNING: Keep the pigtail hose away from sharp edges of the cylinder collar, rigid corners, walls, doors or other compartment structures including the cover.

NOTE: The regulator is typically installed with the inlet fittings at the same level as the cylinder outlet valves. Due to bracket design, wing nut clearance or cover restrictions, the regulator fittings may not be in perfect alignment with the cylinder valves. A variance of two (2) inches (5 cm) above or below the line will permit the hoses to be properly installed.

TWO CYLINDERS (20# OR 30#) (44 OR 66 KILOGRAMS) IN A RECESSED COMPARTMENT OR HOUSING

1. Connect the 3/8" low-pressure hose to the outlet of the two-stage regulator.
2. Place the cylinder on the bracket in the recess compartment or housing and secure them so the outlet of the cylinder valves are facing the "sidewalls" of the compartment or housing.
3. Mount the regulator on the center back wall of the compartment or housing so the vent is pointed downward.
4. Attach the 1/4" inverted flare x 18" Type-1 pigtail hose to the regulator inlet and the right hand swivel nut to the cylinder valve.

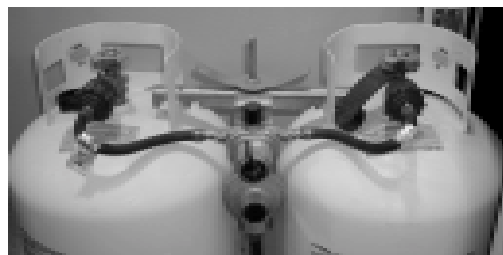

WARNING: The pigtail hose must be installed to avoid tension or pulling stress at either end of the hose.

WARNING: Keep the pigtail hose away from sharp edges of the cylinder collar, rigid corners, walls, doors, or other compartment structures including the cover.

Main Supply Hose – Low Pressure

The main supply hose will be attached from regulator to brass manifold fitting in frame of coach. Swivel brass nut on main hose will be your final attachment. Several things to remember each time container is removed:

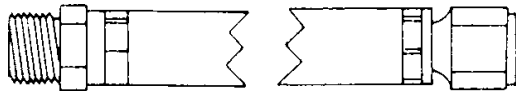

3/8" MPT x 1/2" Female
Flare Swivel

Fig. 4-23

1. Be sure ALL fittings are tight.
2. Be sure ALL connections are tested with leak solution.
3. Open main valve slowly to avoid fast rush of gas to excess flow valve causing gas freeze up. Should you experience a gas “freeze-up,” close main valve and wait 15 minutes before trying again.
4. Listen carefully - a “hissing” sound longer than one second may indicate a gas leak. Close valve and search for leak.

ALL GAS LINES HAVE BEEN CHECKED WITH AIR PRESSURE. DEALERS ARE REQUIRED TO RECHECK AND ADJUST PRESSURE BEFORE DELIVERY TO CUSTOMERS.

Regulator

The regulator is the heart of your LP gas system, with internal moving parts. Its function is to reduce the high and varied pressure from the LP container to safe and consistent low operating pressure. The inlet is the first stage and reduces container pressure to 10-13 pounds. The second stage will reduce the 10-13 pound pressure to an operating pressure of 11" W.C. (Water Column) or 6.35 oz. of outlet pressure to the coach system. The second stage is adjustable and will need to be adjusted for precise operation. We suggest this normal maintenance procedure be performed once per year. Have only an authorized and competent technician make any adjustments.

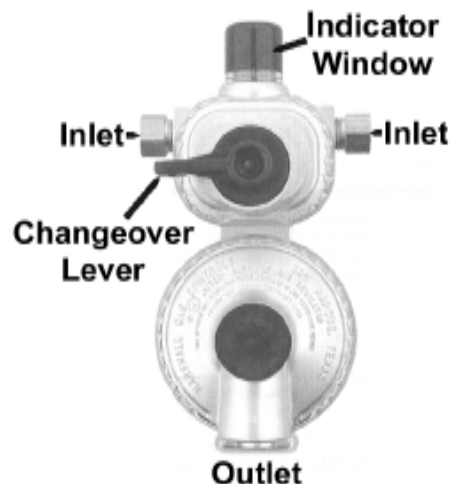

WARNING: LP gas regulators must always be installed with the diaphragm vent facing downward. Regulators that are not in a compartment have been equipped with a protective cover. Make sure that the regulator vent faces downward and that the cover is kept in place to minimize vent blockage which could result in excessive gas pressure causing fire or explosion.

Be sure your LP gas regulator is protected from road spray. If water enters the vent in the regulator, it may freeze the pressure controlling diaphragm in the open position so that the container pressure is applied to the appliances – a hazardous condition. Be sure to carefully read the instructions given by the manufacturer of the regulator.

Automatic Changeover Regulator

The automatic changeover regulator allows both gas bottles to be turned on simultaneously. The arrow on the regulator handle indicates which bottle is in service. When the indicated bottle in service becomes empty, changeover is automatically accomplished to commence drawing fuel from the other bottle. At this point, the plastic window will display a red signal or flag to indicate the condition. The lever should then be flipped over to indicate service on the other bottle. The first bottle which was depleted can then be turned off, uncoupled and taken to be refilled without disturbing the RV gas supply. After refilling, it can be removed and again turned to the “ON” position. When the other bottle is depleted, the LP gas supply will again be automatically changed back to the first bottle.

Operation

After the camper is completely set up and you are prepared for camping enjoyment, follow these steps for LP gas operation.

1. Close ALL burner valves, controls and pilot light valves.
2. Open main valve on LP container slowly to avoid a fast rush through the excess flow valve causing “gas freeze.” Should you experience a gas “freeze-up,” close the main valve and wait 15 minutes before trying again.
3. Listen carefully as gas begins to flow. If “hissing” is heard for more than one or two seconds, close valve and search for leak.
4. Light appliances as needed and directed in the appliance chapter.

WARNING: Portable fuel-burning equipment, including wood and charcoal grills and stoves, shall not be used inside the recreation vehicle. The use of this equipment inside the recreation vehicle may cause fires or asphyxiation.

WARNING: It is not safe to use the cooking appliance for comfort heating. Cooking appliances need fresh air for safe operation. Before operation:

1. Open overhead vent or turn on exhaust fan.
2. Open window.

This warning label has been located in the cooking area to remind you to provide an adequate amount of fresh air for combustion. Unlike homes, the amount of oxygen

supply is limited due to the size of the recreation vehicle, and proper ventilation when using the cooking appliance(s) will avoid danger of asphyxiation. It is especially important that cooking appliances not be used for comfort heating, as the danger of asphyxiation is greater when the appliance is used for long periods of time.

Checking for Leaks

Please refer to Chapter 1, “Safety in Using LP Gas.”

IF YOU SMELL GAS

1. Make sure everyone is out of the RV.
2. Extinguish any open flames, pilot lights, and all smoking materials.
3. Do not touch electrical switches.
4. Shut off the gas supply at the tank valve(s) or gas supply connection.
5. Open doors and other ventilating openings.
6. Leave area until odor clears.
7. Have the gas system checked and leakage source corrected before using again.

LP Gas Consumption

Most gas appliances are operated intermittently. Unless there is heavy use of hot water, the water heater consumption is minimal. During freezing weather and high wind conditions, furnace consumption can be extremely high.

LP gas consumption depends upon individual use of appliances and the length of time operated. Each gallon (3.86 liters) of LP gas produces about 91,500 BTUs (46,514 kilojoules) of heat energy. Following is a list of typical appliance consumption when turned on fully for one hour of operation:

| Appliance | Average BTU Consumption Per Hour | Kilojoules/Hour |
|---------------------------|-------------------------------------|-----------------|
| Water Heater | 8800 – 10,000 | 9280 – 10,550 |
| Refrigerator | 1200 – 1500 | 1270 – 1580 |
| Furnace | 20,000 – 40,000 | 21,100 – 42,200 |
| Range Oven | 7100 | 7490 |
| Range, Rear Burner | 5200 | 5490 |
| Range, Front Burner | 9000 | 9490 |

NOTE: This chart is an example of a typical system and may not represent the exact system in your particular unit.

If you have double bottles on your travel trailer, use only one at a time. Otherwise the gas supply will be drawn equally from both bottles until the supply has been totally exhausted. Using one bottle until it is empty, then using the second bottle will allow you to fill the empty bottle at your convenience without being totally out of propane.

LP DETECTOR

All recreation vehicles with an LP fuel system with propane consuming appliances require a propane leak detection device for safety protection. A converter or auxiliary battery is required to supply 12-volt DC energy to operate the leak detector.

WARNING: Limitations of propane/methane gas detectors:

- **This detector will not work without power. Examples causing no power are: an open circuit breaker, a faulty power line connection, a blown or missing fuse.**
- **This detector will only indicate the presence of propane or methane gas at the sensor. Explosive gas may be present in other areas.**
- **This detector may not be heard. The alarm loudness is designed to meet or exceed regulatory standards, however, the alarm may not be heard if detectors are located in remote locations or behind closed doors. The alarm may not be heard by persons who are hard of hearing.**
- **This detector is not suitable as a smoke or fire detector.**
- **This detector is not suitable for installation in hazardous areas as defined in the national electrical code.**

Operation

Power ON Warm Up: When power is first applied the yellow LED will flash for three minutes while the detector is warming up. At the end of that time the LED will turn Green indicating full operation. If the detector has detected unsafe levels of gas it will immediately go into alarm.

CAUTION: This detector cannot sound an alarm during the three minute warm up cycle.

Testing

WARNING: Test the operation of this detector after the vehicle has been in storage, before each trip and at least once per week during use.

Simply press the TEST switch (Fig. 4-24) any time during the warm up cycle or while in normal operation. The LED should flash RED and the alarm should sound. Release the switch. **This is the only way you should test your detector.** This test feature checks the full operation of the detector. If this detector does not test properly return the detector immediately for repair or replacement.

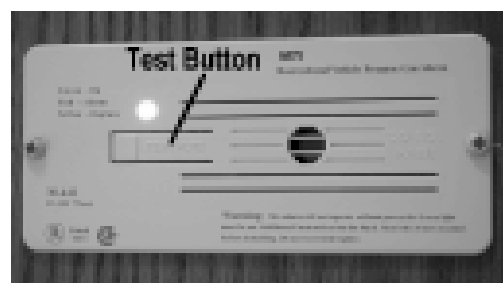

Fig. 4-24

Alarm

The red LED will flash and the alarm will sound whenever dangerous levels of gas are detected. The detector will continue to alarm until the gas clears or the MUTE switch is pressed.

PROCEDURES TO TAKE DURING AN ALARM

1. Turn off all gas appliances (stove, heaters, furnace). Extinguish all flames and smoking material. Evacuate – leave doors and windows open.
2. Turn off the propane container valve.
3. Determine and repair the source of the leak. Seek professional help if necessary.
4. Do not re-enter the unit until the problem is corrected.

ALARM MUTE

This feature is activated by pressing the TEST/MUTE button when the detector is in alarm.

1. The red LED will continue to flash and the alarm will beep every thirty seconds until the gas level has dropped to a safe level.
2. The LED will flash green until the end of the mute cycle.
3. If dangerous gas levels return before the end of the mute cycle, the alarm will beep four times and return to #1.
4. After two minutes, the detector will return to normal operation (solid green) or resound the alarm if dangerous levels of gas remain in the area.

MALFUNCTION ALARM

The microprocessor will activate the malfunction alarm when it detects a fault in the detectors operation. The LED will alternately flash red and green, while the sounder beeps twice every 15 seconds. The mute switch will not function. Remove the detector immediately and return it for repair or replacement.

Low Power Operation

This detector will operate normally down to 7-volt DC. Do not operate this detector below 7-volt DC.

Additional information is supplied in a manual published by the manufacturer of this equipment.

ELECTRICAL SYSTEM

General

The electrical system in your travel trailer is composed of 120-volt AC (alternating current) and 12-volt DC (direct current) capabilities. All installations are made in compliance with safety requirements of ANSI standard A.1192, National Electric Code, and Canadian Standards Association.

All conventional travel trailers and fifth-wheel travel trailers will have 30-amp service pre-wired into breaker box. The option of 50 amp service is available in some models.

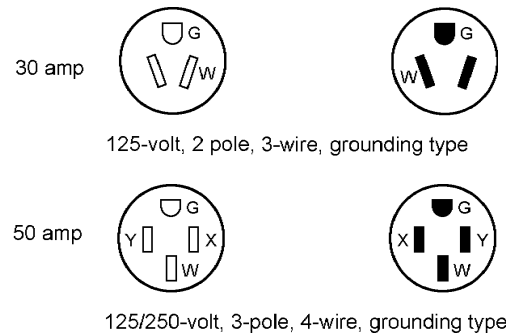

Fig. 4-25

Changes, Modifications and Additions

Any changes or additions made after delivery may cause a hazardous condition. Consult your local authorized dealer prior to making any changes, modifications or additions. Only qualified electrical technicians should attempt to make changes or additions to the electrical system, using only approved materials, components, and employing approved methods of installation, which meet safety and code requirements.

CAUTION: Any electrical installation that does not meet the criteria of the manufacturer's specification will VOID THE WARRANTY on the electrical system.

120-Volt AC System

POWER CORD

Your travel trailer is equipped with a 30-amp rated power cord pre-wired into the breaker box or a 50-amp rated power cord that is stored in the front trunk. By opening the cable hatch door you can pull the power cord out from the compartment and attach it to a power source. The power will enter through the main breaker and is distributed through the circuit breakers to wall receptacles and any appliances wired directly as an air conditioner would be. The cord extends approximately 20'-23' (7 to 10 meters) from the travel trailer depending on floor plan.

To prevent accidental electrical shock, insure that the ground pin on the attachment plug cap is intact to the earth ground through the RV park receptacle. When plugged into a receptacle with no provision for the third pin, use an adapter with a pigtail that can be connected to the receptacle box, with the grounding circuit completed through the ground pin or RV park receptacle box. Any accidental short of a live circuit conductor will trip the circuit breaker indicating a shorted circuit. You should be certain that the polarity of the external power is not reversed, in order to avoid harm to appliances and personal electrical shock. Polarity indicators may be purchased in most electrical and hardware stores.

It is strongly recommended to avoid the use of extension cords. If an extension cord is used, it MUST be the same amperage rating as the RV power cord. Using an improper extension cord will cause overheating of the cord and equipment as well as possibly causing premature failure of the AC equipment.

WARNING: Do not use an adapter, cheater or extension cord that will break the continuity of the grounding circuit connected to the third pin. NEVER remove the grounding pin to connect a non-grounded, two-prong receptacle. Any deviation from this will potentially cause a fire from overheating.

GFCI

Each travel trailer has a GFCI receptacle installed. These initials mean “Ground Fault Current Interrupter.” This special receptacle has been designed to reduce the possible injury caused by electrical shock.

An example of ground fault current is the current which would flow through a person who is using or touching an appliance with faulty insulation and, at the same time, is in contact with an electrical ground such as a plumbing fixture, wet floor, or earth.

This GFCI receptacle will not protect against short circuits or overloads. The circuit breaker or fuse in the electrical panel which supplies power to the circuit provides this protection.

When this GFCI receptacle is tripped, it has interrupted ground fault current caused by such things as faulty insulation or wet wiring inside some appliance or equipment connected to the circuit. The faulty equipment should be repaired before is it used again.

This special receptacle should be tested monthly while the travel trailer is being used.

TESTING INSTRUCTIONS

1. Plug a lamp or radio into the receptacle on the face of the GFCI.
2. Push and release the RESET button.
3. The lamp should light at this time.
4. Press the TEST button.
5. RESET button should pop out indicating “Trip” and the lamp should go out. (If the GFCI is manufactured with an indicator light, the light should glow when the device has tripped.)
6. If the GFCI did not trip, do not use. Call a qualified electrician to service or replace the receptacle. The ground fault protection is no longer working and the GFCI may not be working properly.
7. To restore power after tripping, press in the RESET button. It must remain in. (If an indicator light is furnished, it will be off.)

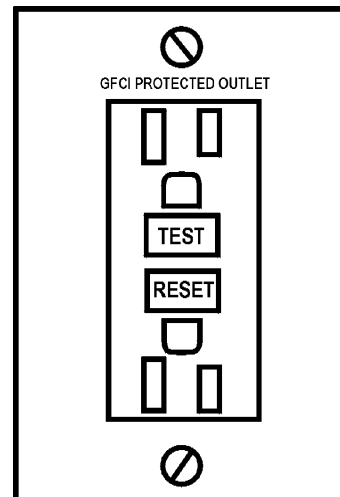

Fig. 4-26

30-AMP SERVICE

On a 30-amp system, up to 5 circuits are permitted to distribute power through the travel trailer. All breakers are sized according to power to be consumed.

WARNING: Do not replace breakers or fuses with any that are rated at a higher amperage. Over fusing may cause a fire by over heating the wire.

Below is a generic drawing with circuit breaker alignment. Your travel trailer may not be exactly the same as shown depending on model, floor plan, and options.

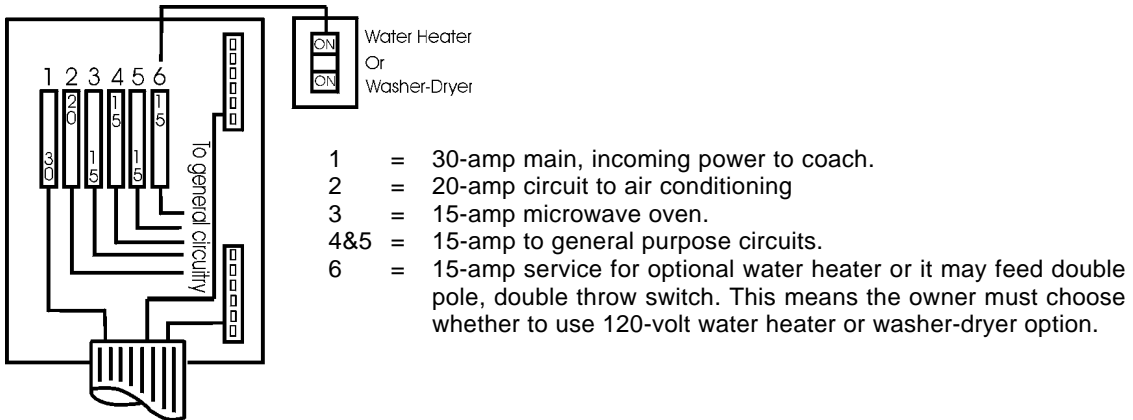

50-AMP SERVICE (OPTION)

A 50-amp service is available on some fifth wheel travel trailers as an option. Below is a generic drawing with circuit breaker alignment. Your travel trailer may not be configured exactly as shown depending on model, floor plan, and options.

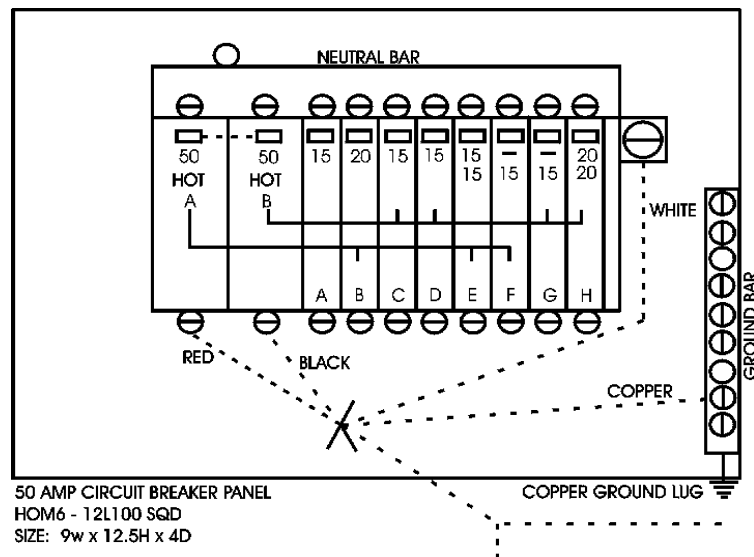

- | | |
|-------------------------------------|-----------------------------------|
| A = 15-amp microwave oven | F = 15-amp washer and dryer |
| B = 20-amp air conditioning | G = 15-amp water heater |
| C = 15-amp refrigerator and utility | H = 20-amp/20-amp air conditioner |
| D = 15-amp GFI and kitchen circuits | |

CONSUMPTION OF 120-VOLT AC POWER

As owners desire and purchase more appliances as we have in our home, we must remember a travel trailer has only 30-amps of incoming power available. Conserving and choosing which appliance has priority in consumption needs to be part of planning.

In addition, loose items such as toasters, skillets, coffee pots, etc. are often included in traveling cargo. Include these in your consumption planning.

12-Volt DC System

The 12-volt DC system is composed of numerous items such as converter, battery, fuses, wire, and bulbs, both interior and exterior lighting. Explanation on these items will follow in this section.

CAUTION: Your RV has many 12-volt DC loads. When combined, they total more power consumption than is available with the 12-volt DC converter. Periodic overloads can be handled with the additional auxiliary battery for short periods of time. It is suggested to conserve your 12-volt DC system at most times. Prolonged overload may shorten the performance life of converter.

CONVERTER

A converter utilizes 120-volt AC power and transforms this energy into 12-volt DC power, which is used inside of your travel trailer. 12-volt DC energy supplies power to all interior lights and various appliances. The floor plan, and size of the travel trailer dictates the model and output size of the converter required.

Inside of the converter is an electronic device which automatically switches between 120-volt AC incoming power and battery power. An auxiliary battery as correctly installed will be charged when the travel trailer is connected up to 120-volt AC power. The converter will supply power through the fuse panel located near by, possibly in the same compartment.

AUXILIARY BATTERY (Option)

All Jayco conventional travel trailers and fifth-wheel travel trailers are designed and built to accept a battery. A deep cycle marine type is recommended as you need longer energy rather than cold cranking power. A battery is required to operate the brakeaway switch and is also available as a source of energy when traveling and camping.

All battery packages require an “in-line” fuse and holder attached to the battery for protection.

Maintenance on a battery is required for longer life. First, all terminals need to be kept clean and free of corrosion. Second, a battery that is used daily or has the converter in operation will consume water. Keep the battery filled as the cells cannot hold a charge when the water is low. A deep cycle battery is NOT maintenance free.

In normal conditions a converter will not overcharge a battery unless (a) the battery has low or dead cell(s), or (b) converter has a malfunction. The charging module on some converters have a positive shut-off and on others there is a reduced charge rate to a very low amperage.

A fully charged battery will read 12.7-volt DC and 1.265 specific gravity at 80°F (32°C). A battery is considered discharged at 11.8-volt DC by electronic standards. When the voltage drops below these levels, permanent damage will occur.

The interior lights will operate from the convertor and/or auxiliary battery. Some lights will have wall switches and other lights have switches in the lights themselves.

The RV battery is installed in parallel circuitry with the battery on your tow vehicle. Both batteries supply power to your RV, so it is important not to discharge the tow vehicle battery below the level of power required to start the engine. To prevent this occurrence while parked, you should disconnect the wiring harness between the RV and tow vehicle or install a battery isolator (see below). When the engine is operating with the RV connected, the vehicle's charging system will charge both the vehicle battery and the auxiliary battery.

BATTERY ISOLATOR (For Tow Vehicle)

A battery isolator should be installed for two purposes. First it receives current from the alternator and controls distribution of energy to both batteries. Secondly, it serves as a check valve to prevent energy from being drawn from tow vehicle chassis battery. Energy in the tow vehicle is now preserved to start your engine.

Two types of isolators are available, mechanical and solid state. Each type has an amperage rating (70-amp per side) to indicate it's capacity of operation. The solid state type of isolator, although typically more expensive, will provide the best overall performance. Your dealer can assist you with purchase and installation.

EXTERIOR LIGHTS

All exterior lights are energized by the tow vehicle power, such as tail lights, clearance lights, turn signals, brake lights, etc. When attaching wire leads to a tow vehicle, carefully and tightly tape all connections for moisture protection.

Refer to diagram (Fig. 4-27) for the color code of the seven wire harness and connector. The connector between the tow vehicle and your travel trailer may build up corrosion with extended use, and should be cleaned periodically to insure good electrical contact.

- White 1 Ground
- Blue 2 Brakes
- Green 3 Running Lights
- Black 4 Interior 12-volt Lighting
- Red 5 Stop & Left Turn
- Brown 6 Stop & Right Turn
- Yellow 7 Back Up

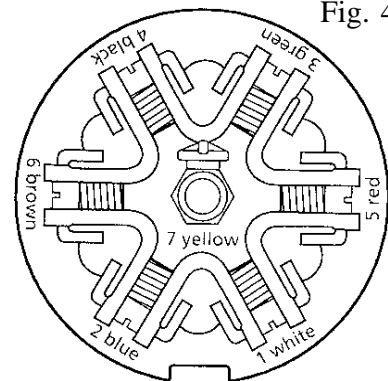

Fig. 4-27

PORCH LIGHT

Any porch light on either sidewall will have switches located on the wall inside of the entrance door.

Front convenience lights on Fifth-Wheel Travel Trailers or Conventional Travel Trailers will have a switch included with the light assembly and fused through the fuse panel.

Television Cable

The television cable is rated RG-6 to accept satellite dishes.

Fluorescent Lighting (Option)

Each fluorescent light in the unit contains two eight watt tubes, replacement number F8T5. To extend the life of the tubes by 30 percent, rotate the tubes once per year per the rotation sequence shown below:

Bulbs

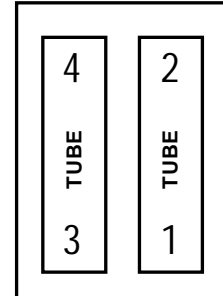
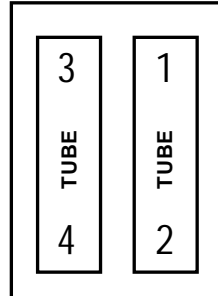
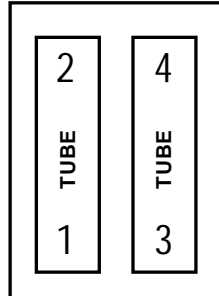
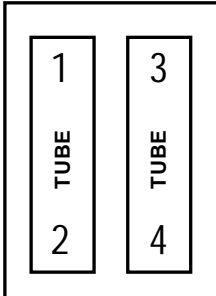

Interior: Fluorescent #F8TS
 Square lights #921
 Round Lights #912
 Power Hood Lights . . . #912
 Brass Light . . . Frosted #921

Exterior: Porch Light #912
 Tail Light #1157
 Turn Signal & Brake . . . #1157
 Backup Light #1156
 Clearance Light #194

Fuse and Bulb Chart

Fuses: All fuses for the interior of coach and external porch lights are located in the fuse panel. This panel is located near the converter.

WARNING: Do not replace circuit breakers or fuses with a higher current rating than those supplied with the new camper. Over-fusing can cause a fire hazard by overheating the electrical wiring.

DC Fuse Panel Layout

Note: Below is a typical wiring layout. Your individual travel trailer may be different.

| POSITION | CIRCUIT NO. | FUSE SIZE | DESIGNATION |
|-----------------------------|-------------|------------|--|
| 6 Positions (Fig. 4-28) | 1 | 15 | Monitor Panel/Range Hood/Pump |
| | 2 | 15 | Front Bed Lights |
| | 3 | 15 | Refrigerator/Furnace |
| | 4 | 15 | Bath Lights |
| | 5 | 15 | Entry Lights |
| | 6 | 15 | TV/Radio/Lights |
| 9 positions (Fig. 4-29) | 7 | 15 | Main Slideout (1) Lights/Security Lights |
| | 8 | 20 Reset | Main Slideout (1) Motor |
| | 9 | 12.5 Reset | Bed Slideout (2) Motor |
| 12 Positions (Fig. 4-30) | 7 | 15 | Main Slideout (1) Lights/Security Lights |
| | 8 | 15 | Dinette Slideout (2) Lights |
| | 9 | 15 | Spare |
| | 10 | 20 Reset | Main Slideout (1) Motor |
| | 11 | Spare | +2 |
| | 12 | 12.5 | Bed Slideout (3) Motor |

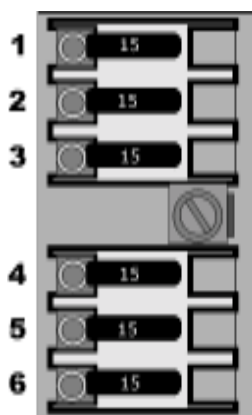

Fig. 4-28

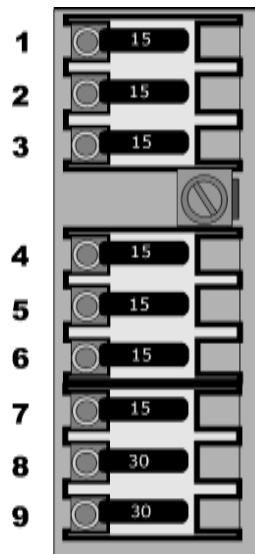

Fig. 4-29

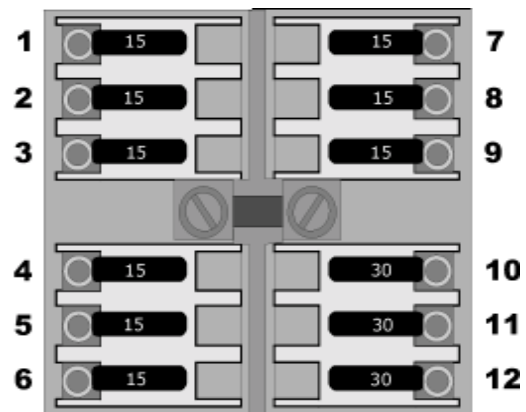

Fig. 4-30

Brakes

The electric brakes operate on 12 volt DC power from tow vehicle through blue and white wires on 7 way pigtail and harness. More information on the brakes is found in Chapter #3.

CHAPTER 5 APPLIANCES

GENERAL

All appliances in your Jayco RV are name brand quality built equipment, guided by current code and standards. For gas operation, the appliances in your travel trailer will operate on LP gas only, not on natural gas. All safety precautions for LP gas from Chapter 4 must be followed during operation of the appliances. Please familiarize yourself with them before proceeding.

Included with each travel trailer are specific operation manuals, written and published by the manufacturer for each appliance. Refer to these owner's manuals for additional information not covered in this manual.

FURNACE

The furnace requires both 12-volt DC and LP gas energy for full operation. The combustion system is fully sealed. Oxygen is drawn from outside through the center port of the vent by the fan motor. After burning fuel, the carbon monoxide exhaust is expelled into open air through the outer port of the vent. This vent is NOT to be altered or obstructed in any manner to ensure your personal safety.

In order for the furnace to operate, a fully charged 12-volt DC battery or 120-volt AC power through a converter must be available.

Two types of thermostats are used in campers. Thermostats are generally installed on an inner wall of a cabinet.

The thermostat in Fig. 5-1 is used for travel trailers which DO NOT have central air conditioning. The furnace is D.S.I. (direct spark ignition) in operation and all functions will be performed at the thermostat.

The thermostat in Fig. 5-2 is used in travel trailers with a central air conditioning system. The furnace will operate by moving the switch to "heat" position on the system side control. The furnace has it's own fan. No movement is needed on the "fan" side.

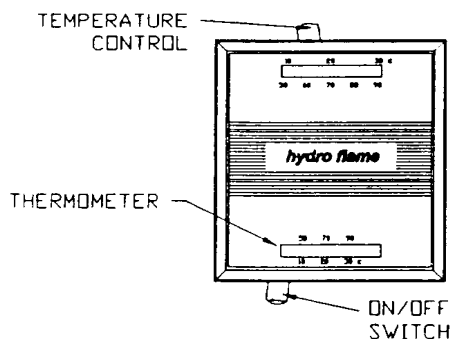

Fig. 5-1

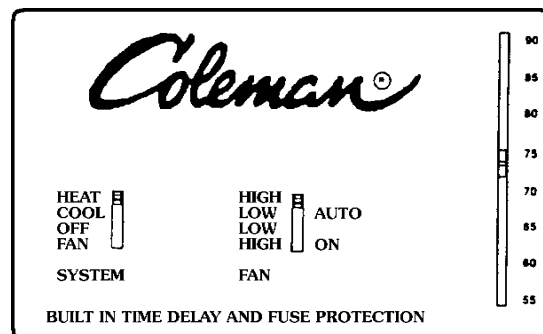

Fig. 5-2

For Your Safety (Read Before Operating)

WARNING: If these instructions are not followed precisely, a fire or explosion may result causing property damage, personal injury or loss of life.

- A. This appliance does not have a pilot light. It is equipped with an ignition device that automatically lights the burner. Do not try to light the burner by hand.
- B. Prior to operation, smell the area around the appliances to ensure that gas has not settled on the floor.
- C. **WHAT TO DO IF YOU SMELL GAS**
 - Evacuate all persons from the vehicle.
 - Shut off the gas supply at the gas container or source.
 - Do not touch any electrical switch or use phone or radio in the vehicle.
 - Do not start the vehicle's engine or electric generator.
 - Contact the nearest gas supplier or qualified service technician for repairs.
 - If you cannot reach a gas supplier or qualified service technician, contact the nearest fire department.
 - Do not turn on the gas supply until the gas leak(s) has been repaired.
- D. Use only your hand to turn a gas control valve. Never use tools. If the valve will not turn by hand, do not try to repair it. Call a qualified service technician. Using force may result in a fire or explosion.
- E. Do not use the appliance if any part has become wet. Immediately call a qualified service technician to inspect and replace any part of the control system and gas control which has been under water.

Operating Instructions

1. STOP! Read the safety information above.
2. Set the thermostat to lowest setting.
3. Turn off all electric power to the appliance.
4. This appliance is equipped with an ignition device which automatically lights the burner. Do not try to light the burner by hand.
5. Open the control access panel.
6. Turn the valve power switch to "OFF."
7. Wait five minutes to clear out any gas. Then smell for gas, including near the floor. If you smell gas, STOP! Follow "C" in the safety information. If you do not smell gas, go to the next step.
8. Turn the valve power switch on to the valve.
9. Close the access panel.
10. Turn on all electric power to the appliance.
11. Set the thermostat to desired setting.
12. If the appliance will not operate, follow the instructions TO TURN OFF GAS TO APPLIANCE (below) and call your service technician or gas supplier.

To Turn Off Gas to Appliance

1. Set the thermostat to lowest setting.
2. Turn off all electric power to the appliance if service is to be performed.
3. Open the access panel (Outer Door Assembly) to turn off the electric switch.
4. Close the control access panel (Outer Door Assembly).

Maintenance

See “Furnace Maintenance” in Chapter 7.

Ducting and Return Air

All heat discharges, registers and return air grills must be free and clear of obstructions. Obstructions will prevent the furnace from performing correctly. This includes all closable registers that are intended to reduce air flow, not shut it off completely.

RANGE AND OVEN OPERATION

WARNING: Personal Injury Hazard

- **Do not touch or allow clothing and flammable materials to come in contact with burner grates or areas near top burners until they have sufficient time to cool. These areas become hot enough to cause burns and fires.**
- **Ensure that pans used are large enough to contain food and avoid boil overs. Heavy splattering or spills left on the cooktop can ignite and cause burns.**
- **Ensure that glass cookware is safe for use on the top burners. Only certain types of glass cookware is suitable for surface or top burner use.**
- **Never leave top burners unattended.**
- **Turn pan handles inward, but not over other top burners. This will reduce the chance of burns.**
- **Grease is flammable. Never allow grease to collect around top burners or on cooktop surface. Wipe spills up immediately.**
- **Do not use water on grease fires. Never pick up a flaming pan. Smother a flaming pan with a tight-fitting lid or cookie sheet. Flaming grease outside of the pan can be extinguished with baking soda or a multipurpose dry chemical or foam-type fire extinguisher.**

To light the top burners on the range and cooktop models equipped with spark ignition:

- a. Turn the appropriate burner knob counterclockwise to “ON” or “LITE/HI.” Do not attempt to light more than one burner at a time.
- b. On three burner models, turn the “SPARK” knob clockwise one click. If the burner fails to light, continue turning the “SPARK” knob clockwise until the burner lights.
- c. On four burner models, wait approximately seven seconds after turning the burner knob to “ON”; press the “SPARK” button once to light the burner. If the burner fails to light, continue pressing the “SPARK” button until the burner lights.
- d. To extinguish the top burner flame, turn the appropriate burner knob clockwise to “OFF.”

WARNING: Ensure that stove knobs are pushed all the way onto the stems when in the “OFF” position. Failure to do so could result in the stove inadvertently being turned on. If camping with small children, you may want to utilize stove knob covers that are available at your local hardware.

WARNING: Burn, Fire and Explosion Hazard

- **Use care when lighting a top burner by hand. If the burner lights unexpectedly, or your hand is close to the burner, you may be burned.**
- **If any burner should extinguish (after initially lighting or due to accidental blow-out) turn gas supply off and WAIT FIVE MINUTES before again attempting to light the burner. Failure to follow these instructions may result in a fire or explosion.**

Oven Operation

WARNING: Personal Injury Hazard

- **Do not touch or allow clothing or flammable material to come in contact with the inner or outer surfaces of the oven or the oven vent while it is in use. These areas all are hot enough to cause burns. Allow sufficient time for them to cool.**
- **Do not cover the oven vent openings while the oven is in operation. Restricting the flow of combustion air will create an asphyxiation hazard.**

Step 1 – To Light the Oven Pilot

- a. Push in the oven control knob and rotate counterclockwise to “PILOT ON”.
- b. Light the oven pilot located near the back of the oven, under the broiler shelf and to the left of the oven burner.
- c. Set the oven control knob to “PILOT ON” to maintain pilot flame. The oven and broiler are now ready for operation; see Step 2 before proceeding. The oven pilot has been factory set and requires no further adjustment.
- d. To extinguish the oven pilot, push in the oven control knob and rotate clockwise to “OFF.” Extinguish all pilots when refueling or traveling.

Step 2 – To Light the Oven

- a. Light the oven pilot as described in Step 1.
- b. With the oven control knob set to “PILOT ON,” rotate the knob counterclockwise to the desired temperature setting or to “BROIL.”
- c. The oven is equipped with a safety ignition system that requires a minimum of thirty seconds to operate after turning the oven control “ON.” This delay is normal.
- d. To extinguish the oven burner, rotate the knob clockwise to “PILOT ON.” The oven pilot will remain lit.
- e. For complete shutdown, rotate the knob clockwise to “OFF.”

WATER HEATER

Several options are available in the water heater appliances. (1.) 6 or 10 gallon (24 or 40 liters) capacities, depending on floor plan. (2.) Three types of energy, LP gas only, LP gas and 120-volt AC combination, and 12-volt DC /LP gas combination with 120-volt. Water temperature is adjustable on pilot and 120-volt AC models, but not on the combination unit.

Pilot Operation

CAUTION: Do not tamper with the pilot orifice. High water temperature and failure of the gas control could result.

1. Turn lighting control (fig. 5-3B or 5-4B) to “OFF” position.
2. Wait at least five minutes to allow gas which may have accumulated in burner compartment to escape.
3. Note that your water heater may have either a “White Rodgers” or Robertshaw “Unitrol” Control.

FOR “WHITE RODGERS” CONTROL (FIG. 5-3)

- a. Turn lighting control knob (Fig. 5-3B) to “pilot” position and hold against stop while lighting pilot burner (Fig. 5-5D)
- b. Allow pilot to burn approximately one half minute before releasing lighting control knob.
- c. Turn lighting control knob (Fig. 5-3B) to “ON” position.
- d. If pilot does not remain lit, repeat operation allowing longer period before releasing lighting control knob.
- e. Set the temperature selection lever (Fig. 5-3A) at the mark between the warm and hot position.
- f. Close access door.

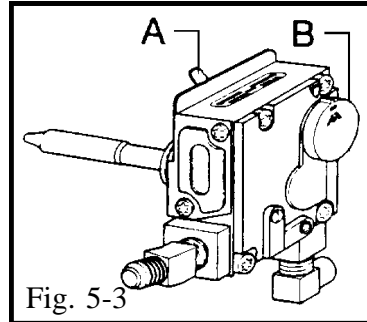

FOR A ROBERTSHAW “UNITROL” (FIG. 5-4)

- a. Turn lighting control dial (Fig. 5-4B) to “pilot” position.
 - b. Depress and hold reset push button (Fig. 5-4A) while lighting pilot burner (Fig. 5-5D).
 - c. Allow pilot to burn for one half minute before releasing reset push button.
 - d. If pilot does not remain lit, repeat operation allowing longer period before releasing reset push button.
 - e. Turn lighting control dial (Fig. 5-4B) to “ON” position.
 - f. Set the temperature control dial (Fig. 5-4C) at the midpoint position between warm and hot.
 - g. Close access door.
4. For complete shut down and before servicing, turn lighting control knob (Fig. 5-3B or 5-4B) to “OFF” position.

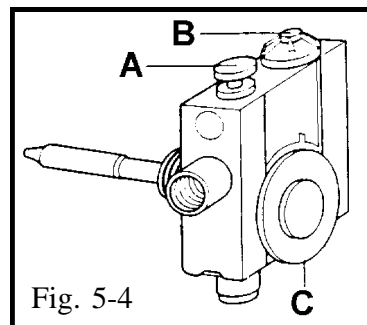

CAUTION: Setting the temperature control dial at a higher position will produce water that is hotter, increasing the risk of scalding.

The temperature knob or lever is factory adjusted to its lowest dial setting. It is recommended that the midpoint position between warm and hot be used. This will provide for energy efficient operation and sufficient hot water. Valves for reducing point of use temperature by mixing cold and hot water are available. Consult a licensed plumber or your local plumbing authority.

To adjust Main Burner (Fig. 5-5):

1. Loosen air shutter screw (Fig. 5-5A).
2. Slide air shutter (Fig. 5-5B) to the right until a small amount of yellow color appears in the main burner flame.
3. Move air shutter (Fig. 5-5B) to left until yellow disappears.
4. Retighten air shutter screw (Fig. 5-5A).

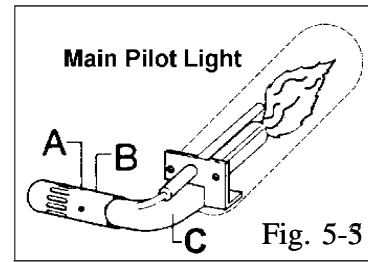

Electric Ignition Operation

1. To turn D.S.I. on press rocker switch to the “ON” position. Light will come on indicating power to board. As soon as burner ignites the light in switch will go off.
2. If remote switch light stays on longer than fifteen seconds, place remote switch in OFF position and wait five minutes.
3. Repeat step one.
4. When water temperature reaches the permanent set thermostat, flame shuts down. Reignition will occur when water temperature drops to 100° (38°C) automatically.
5. For complete shutdown and before servicing:
 - a. Place remote switch in “OFF” position.
 - b. Remove red wire from left hand terminal of ECO switch (ECO to valve).

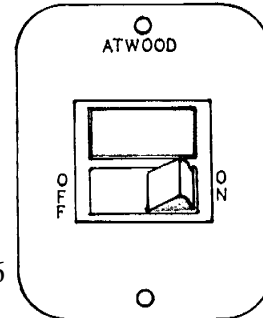
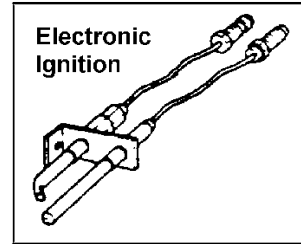

Fig. 5-6

6. If heater fails to operate due to high water temperature, the heater will go into a lockout condition (indicator light on). When water cools, reset by placing switch in “OFF” position for at least thirty seconds, then return to “ON” position.
7. If a lockout condition persists contact your dealer, an Atwood service station or Atwood service department.

NOTE: Terminals on switch #2 and 3 supply power to heater. Terminals 4 and 6 supply power to light. Some models may have switch for D.S.I. water heaters in monitor panel.

Pilot Re-ignite Operation

1. Turn the switch located on the spark module to the “ON” position.
2. Read Pilot Operation Instructions.

WARNING: The pilot relight module and thermostat lighting control knob must both be in the “OFF” position when refueling the LP tank or gasoline tank. Fire and/or explosion could result.

3. For complete shut down, turn lighting control knob on thermostat and spark module switch to the “OFF” position.

Electric Operation

1. For gas operation refer to Pilot Operation or Electronic Ignition Operation section.
2. For electrical operation, use the switch inside the travel trailer in the utility panel.
3. Completely fill tank with water.
4. Turn switch (Fig. 5-7) located in the travel trailer to the “ON” position.

NOTE: Turning the power on in the heater with little or no water covering the heating element may burn out the element and void the warranty.

5. Check for proper operation. Water temperature should be approximately 140°F (60°C).
6. If the manual reset high temperature limit switch should operate, reset the switch (Fig. 5-8) by depressing the button. Use a pencil or other nonmetallic object to depress the reset button. If the malfunction repeats, contact an authorized Atwood Service Center or Atwood Service Department.

When cold water is heated in the tank, the pressure will rise. For this reason, a relief valve (Fig. 5-9) is required for safety in all water heaters, rated at 125° (52° C). It is normal for this valve to release a small quantity of water during the heating cycle. Opening a faucet on the hot side will release pressure reducing relief valve dripping.



Fig. 5-7

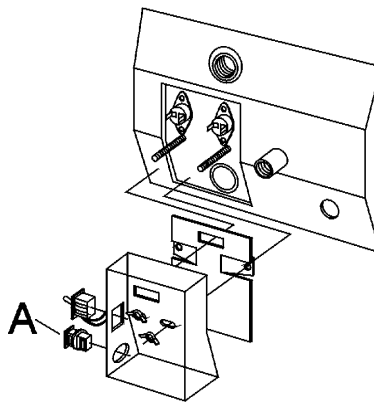

Fig. 5-8

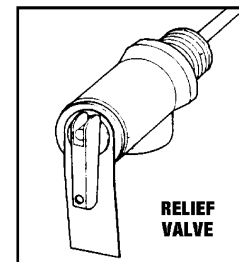

Fig. 5-9

PRESSURE TEMPERATURE RELIEF VALVE

WARNING: Do not plug the pressure-temperature relief valve under any circumstances.

When cold water is heated in the tank, the pressure will rise. For this reason, a relief valve (Fig. 5-9) is required for safety in all water heaters rated at 125°. It is normal for this valve to release a small quantity of water during the heating cycle. Open the hot water faucet to release pressure which will reduce the dripping from the relief valve.

Flushing Instructions

If your travel trailer is used frequently, or taken to different areas that use various types of water, it is recommended that the water heater be flushed periodically throughout the year to prolong the life of the inner tank. The following procedure summarizes the steps necessary for flushing the water heater inner tank.

CAUTION: Turn off the water heater and allow time for the water to cool before removing the drain plug to flush the tank.

1. Turn off your main water supply (pump or water hook-up source).
2. Drain the water heater inner tank. Approximately two quarts of water will remain in the bottom of the tank. This water contains a great deal of the harmful corrosive material that has accumulated in the tank.
3. Flush tank with air pressure or fresh water to remove the remaining water.
Air Pressure: Air pressure may be applied through the inlet or outlet valve located on the rear of the tank or the relief valve (Fig. 5-9) located on the front of the unit. If the relief valve is used, remove the relief valve prior to flushing and insert air pressure through the relief valve support flange.
Fresh Water: Pump fresh water into tank with the assistance of an onboard or external water pressure. The water may also be hosed into the tank through the inlet or outlet valve located on the rear of the tank or the relief valve located on the front of the unit. Continue this process for approximately five minutes, allowing ample time for the water to agitate the stagnant water on the bottom of the tank and thus forcing any corrosive material through the drain opening.
4. Close the drain and relief valves.

REFRIGERATOR - RV TYPE

This appliance in your Jayco recreation vehicle has been designed by its manufacturer to operate on 120-volt AC electric or on LP gas energy. Its performance depends on numerous factors such as energy, venting, leveling, humidity and atmosphere temperatures. It is best to cool the refrigerator for eight hours prior to loading it with food. The refrigerator is not intended for quick freezing or cooling, so be sure to load it with already frozen/cooled food. Air must be free to circulate withing the fresh food compartment. **Do not cover the shelves with paper, plastic, etc.**

Leveling

Comfortable vehicle leveling is well within the refrigerator's operating requirements of three degrees off level side-to-side and six degrees off level front-to-back (looking at the front of the refrigerator). Continued operation outside of these limits can result in irreparable damage to the cooling system.

Venting

For the refrigerator to operate correctly there are two vents that must be unrestricted in your travel trailer. The first vent is located in the lower portion of the sidewall. It is a hinged or removable panel that allows access to service compartments on the refrigerator. The second vent is located in the roof of the travel trailer, above the coils on the rear side of the refrigerator. Please note, birds might build nests in this vent. It is advisable to retain the screen over the base to prevent this from occurring.

Door Seal

To maintain cooling efficiency and prevent excessive frost buildup, the doors must seal completely around the entire length of the door gasket. Frequent frost buildup or reduced cooling are indications of air leaks. To check for complete door sealing, lay a long strip of paper or a dollar bill across the flange, against which the gasket seals; then close the door. A frictional drag should be felt when withdrawing the paper. Repeat in several places all around the door. If the paper feels loose, the gasket is not sealing. Contact your dealer or service center.

CAUTION: Do not use undue force or jerking action when opening the refrigerator door. Air temperature differences can cause a partial vacuum within the cabinet requiring a firm but steady force to open the door. A sudden jerk could cause door damage or personal injury.

Battery Drain

As indicated, a 12 volt DC source is required for operation on gas to provide features of automatic ignition. The drain on the battery is very low and has little effect on “battery run down” unless these switches are left on for long periods of time on a battery with no means of recharging. The DC voltage should be checked while operating in the DC mode. The voltage at the refrigerator should never drop below 11.5 volts.

Battery drain should also be considered during times when the refrigerator is stored, defrosted, or occasions when the door is left open. The humidity heater, if left on, draws 240 milliamps. Because of this small drain, the NORMAL-STORAGE-HIGH HUMIDITY switch should be set to the STORAGE position.

Except for DC operation (three-way models) it is evident that the 12 volt DC demand is quite low; nevertheless, the refrigerator should not be operated for long periods of time from a battery only, without a means of recharging through the alternator or converter.

Controls

CAUTION: Never allow water to be sprayed directly on electrical controls located behind the inlet vent door. Electrical damage or fires could result.

1. Be attentive when the outer surface is being hosed down to avoid wetting the refrigerator controls.
2. The user should be aware that 12-volt DC is required during all operating modes (AC, GAS, DC).
3. This Norcold refrigerator is equipped with electronic ignition (no pilot flame). It provides automatic gas ignition on start up, automatic re-ignition in case of flame blowout and electrical signal to warn of flame failure (red X on annunciator panel).

N621 AND N841 SERIES REFRIGERATORS

Door Handles

During travel, the door latch prevents the door from opening. When closing the door, push the door toward the refrigerator until you hear a “click” sound. To open the door, pull the handle away from the refrigerator.

During storage, the storage latch prevents the door from completely closing. Use it to prevent odors when the refrigerator is stored for an extended period of time. To operate the storage latch, open each door about 1/2 inch (1 cm) and push the storage latch into the cutout of the strike plate. Do not use the storage latch as a travel latch because the doors will not be fully closed.

Interior Light

The interior light is at the top of the fresh food compartment. It comes on only when the refrigerator is ON and the door is open. To replace the bulb:

1. Remove the DC power supply wires from the power board at the rear of the refrigerator
2. Remove the cover. On the model N621, pull the cover toward the front of the refrigerator. On the model N841, push the cover toward the rear of the refrigerator.
3. Remove the light bulb from the holder.

NOTE: Use only a GE#214-2 bulb as the replacement bulb. This bulb is available at most retail automotive parts centers.

4. Install the replacement bulb.
5. Install the cover.
6. Connect the DC power supply wires to the power board at the rear of the refrigerator.

Door Alarm

The refrigerator has an alarm to alert you if the fresh food compartment door is not fully closed. The refrigerator continues to operate, but if the fresh food compartment door is open and the interior light remains on for two minutes:

- An audible alarm starts.
- “dr” appears in the center display.
- Light turns off.

Close the door to silence the alarm.

Backup Operating System

This refrigerator has a backup operating system. The backup operating system allows the refrigerator to continue to cool if the temperature sensor of the refrigerator should fail. If this failure occurs, the refrigerator automatically changes to the backup operating system. When you push the TEMP SET button, the temperature setting flashes in the center display for ten seconds. After the temperature setting flashes, the mode of operation appears in the center display.

NOTE: If you open the door(s) too often, the temperatures inside the freezer and fresh food compartment do not become stable. Allow the refrigerator to operate for about one hour after each adjustment change before to examine the contents. The number “9” is the coldest temperature setting.

Have the refrigerator serviced by your dealer or an authorized Norcold Service Center as soon as possible.

Operating the Refrigerator Controls – N621

CONTROL PANEL

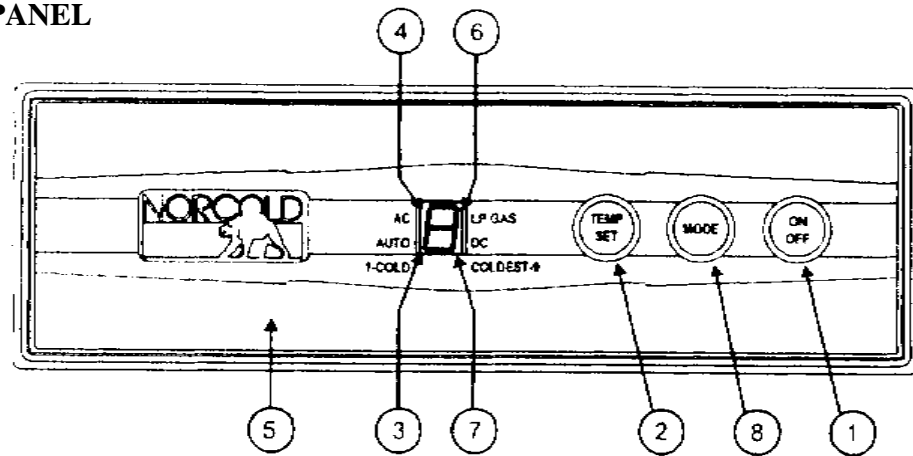

Fig. 5-9

The refrigerator control panel is between the freezer compartment and the fresh food compartment.

The ON/OFF button (1) starts and shuts down the refrigerator. If the refrigerator is shut down, press the ON/OFF button to start the refrigerator in auto mode. If the refrigerator is operating, press and hold the ON/OFF button for two seconds to shut down the refrigerator.

The TEMP SET button (2) controls the temperature adjustment of the freezer and the fresh food compartment. The temperature adjustment that you select does not change if the mode of operation of the refrigerator changes. Press the TEMP SET button and the temperature setting “1-9” appears in the center display (3). Push and hold the TEMP SET button and the temperature setting changes. The number “9” is the coldest temperature setting.

The MODE button (8) controls the operation mode of the refrigerator. Push and hold the MODE button and a light bar flashes in the center display beside each of the four operating modes of the refrigerator, one at a time. There is one automatic mode of operation, and three manual modes of operation. When the light bar flashes beside the mode of operation that you wish, release the MODE button.

AUTOMATIC MODE OPERATION

When you select AUTO mode, the refrigerator controls automatically select the most efficient energy source that is available for operation. If a more efficient energy source becomes available, the refrigerator controls change from the current energy source to the more efficient energy source.

If an energy source is available to the refrigerator, but is not operating correctly: A fault code appears in the center display. The refrigerator controls try to change to a less efficient energy source. If a less efficient energy source is not available, the refrigerator stops operation. Refer to the “Fault Codes” in the manufacturer’s owner’s manual.

MANUAL MODE OPERATION

When you select one of the manual modes of operation, the light bar beside the AUTO goes out in the center display and only the light bar beside either AC, LP, or DC remains. AC means that the refrigerator is operating on AC electric. LP means that the refrigerator is operating on LP gas. If the energy source is interrupted, the refrigerator stops operation. Refer to the “Fault Codes” in the manufacturer’s owner’s manual.

IGNITION OF LP GAS IN EITHER AUTO OR MANUAL MODE

Note: On initial startup of the refrigerator, ignition of the LP gas may not occur within 30 seconds.

If ignition of the LP gas does not occur with 30 seconds, the gas safety valve of the refrigerator closes, and the refrigerator stops operation. Refer to the “Fault Codes” in the manufacturer’s owner’s manual. The fault code remains until you push the ON/OFF button two times (to stop and start the refrigerator). If ignition does not occur after two or three times, check the LP gas supply line; consult your local dealer or an authorized Norcold Service Center; change to manual mode and operate on AC electric.

Operating the Refrigerator Controls – N841

CONTROL PANEL

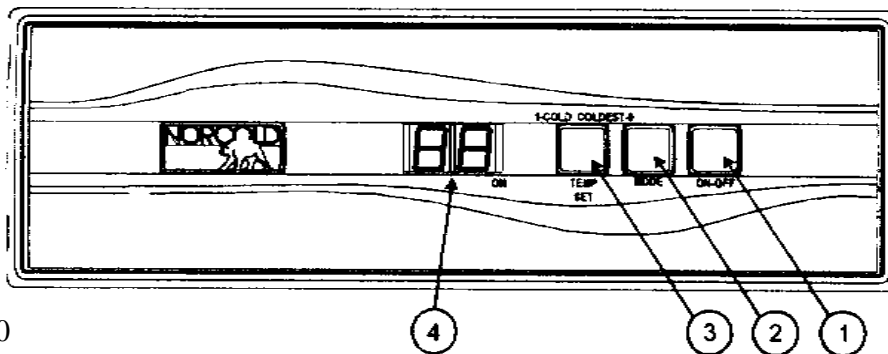

Fig. 5-10

The refrigerator control panel is between the freezer compartment and the fresh food compartment. To maintain the operating control functions of the refrigerator, a 12 volt DC power supply is necessary. The refrigerator and any other DC components in the vehicle receive DC power from the 12 volt system of the vehicle; either an auxillary battery, a converter, or the vehicle engine battery.

The ON/OFF button (1) starts and shuts down the refrigerator. If the refrigerator is shut down, press the ON/OFF button to start the refrigerator in auto mode. If the refrigerator is operating, press and hold the ON/OFF button for two seconds to shut down the refrigerator.

The TEMP SET button (3) controls the temperature adjustment of the freezer and the fresh food compartment. The temperature adjustment that you select does not change if the operation mode of the refrigerator changes. Press the TEMP SET button and the temperature setting “1-9” appears in the center display (4). Push and hold the TEMP SET button and the temperature setting changes. The number “9” is the coldest temperature setting.

The MODE button (2) controls the operation mode of the refrigerator. Push and hold the MODE button and each of the four operating modes of the refrigerator flash one at a time in the center display. There is one automatic mode of operation, and three manual modes of operation. When the mode of operation that you wish shows in the center display, release the MODE button.

AUTOMATIC MODE OPERATION

When you select AUTO mode, the refrigerator controls automatically select the most efficient energy source that is available for operation. If a more efficient energy source becomes available, the refrigerator controls change from the current energy source to the more efficient energy source.

If an energy source is available to the refrigerator, but is not operating correctly: A fault code appears in the center display. The refrigerator controls try to change to a less efficient energy source. If a less efficient energy source is not available, an audible alarm sounds, and the refrigerator stops operation. Refer to the “Fault Codes” in the manufacturer’s owner’s manual.

MANUAL MODE OPERATION

When you select one of the three manual modes, “AU” goes out in the center display and either AC, LP, or DC appears. AC means that the refrigerator is operating on AC electric. LP means that the refrigerator is operating on LP gas. DC means that the refrigerator is operating on DC electric. If the energy source is interrupted, an audible alarm sounds, and the refrigerator stops operation. Refer to the “Fault Codes” in the manufacturer’s owner’s manual.

IGNITION OF LP GAS IN EITHER AUTO OR MANUAL MODE

NOTE: On initial startup of the refrigerator, ignition of the LP gas may not occur within 30 seconds.

If ignition of the LP gas does not occur with 30 seconds, the gas safety valve of the refrigerator closes.

In the auto mode, the refrigerator control changes to a less efficient energy source (3-way models only); the fault code “no” “FL” shows in the center display (2-way models only).

In the manual mode and operating on LP gas, an audible alarm starts, and the fault code “no” “FL” shows in the center display. The audible alarm and the fault code remain until you push the MODE button. Push the ON/OFF button two times to stop and start the refrigerator.

If ignition does not occur after two or three times, check the LP gas supply line; consult your local dealer or an authorized Norcold Service Center; change to manual mode and operate on AC electric, or DC electric (3-way models only).

Ice Maker

Ice maker is assembled to the refrigerators at the factory as optional equipment. If the refrigerator does not have a factory installed ice maker, one can not be added to the refrigerator at a later time.

ICE MAKER OPERATION

1. Open the water shut off valve of the vehicle.

NOTE: Make sure that the ice maker arm can move freely and does not touch the frozen foods in the freezer

2. Push the ice maker arm down to the ON position.

CAUTION: If you operate the refrigerator without connecting the water supply line and/or opening the water shut off valve of the vehicle, make sure the ice maker arm is up in the OFF position.

3. Allow the freezer to cool to 32° F (0° C) (a minimum of 24 hours) and ice production will begin to fill the storage bin.

NOTE: New plumbing connections and/or impurities in the water supply line after winterizing can cause the first ice to be discolored or have an odd flavor.

4. To stop the ice maker, push the ice maker arm up to the OFF position.

REFRIGERATOR - RESIDENTIAL UNITS

Refer to the owner's manual supplied with your unit.

CAUTION: Ensure travel strap is in place prior to travel.

MONITOR PANEL

The monitor panel will provide useful information on the capacities of the water tanks and the battery condition. In fifth wheel travel trailers and conventional travel trailers you will find a wall mounted panel as shown. Follow instructions below regarding operation.

The panel operates on 12-volt DC power supplied by the converter or battery. Sensors are installed into the tanks and a resistor assembly relaying a message through wires to the display board on the panel. No power is drawn from the battery unless a switch is pushed or turned on.

Operation

Four spring loaded push button switches are located in the center of panel. Press only one button at a time, as one set of lights serve all functions. As you push any button, one or more lights will come on, indicating the water level of that tank.

When pushing the battery button, the highest light coming on indicates battery condition. C=charging at 12.7 volts; G=good at 11.9 volts; F=fair at 11.2 volts; and L=low at 6.0 volts.

The switch at the lower right is for water pump operation. In the “ON” position, the pump runs until 45 pounds of pressure has been achieved. The red light will stay on. Turn the switch off when the pump is not in use.

The switch in the lower left corner is for direct spark ignition (D.S.I.) water heater operation if the D.S.I. option is built into your travel trailer.

Fuses for the monitor panel operation are in 12-volt distribution center fuse block.

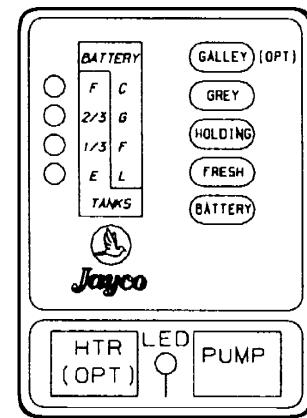

Fig. 5-11
(Eagle/Qwest)

(Designer Model Option)

1. Press TEST spring loaded button to indicate battery voltage and water level in each tank.
2. Press PUMP button to turn water pump on or off.
3. Press HEATER switch to turn water heater on or off.

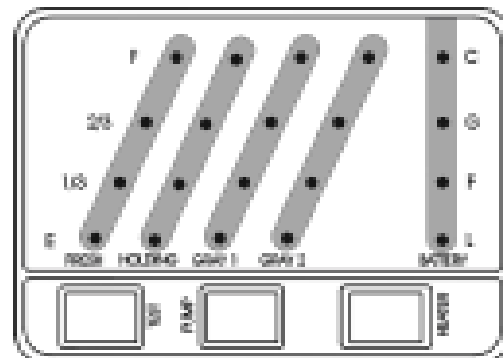

Fig. 5-12

BBQ GRILL (Option)

WARNING: The maximum weight limit for the bracket on the side of your travel trailer is 50 lbs. This limit includes the weight placed on the BBQ grill. Exceeding this weight limit could cause damage to the unit and possibly cause personal injury from hot equipment.

An option for your travel trailer is a BBQ Grill. This grill is for use outside of the travel trailer and comes with a bracket to attach to the side of the unit. The following list will supply basic operations for the grill. Be sure to read all instructions included with the grill.

1. Install the grill bracket on the side of the travel trailer mounting bracket. Make sure that it is securely in place.
2. Place the BBQ grill into the bracket. (Fig. 5-13)
3. Attach the fuel hose to the grill and the LP gas connection located under the travel trailer by using the “Quick-Coupler” instruction as follows (Fig. 5-14):
 - Place the handle in the “OFF” position and push back the sleeve. Valve handle must be in the “OFF” position to make the connection. (Fig. 5-15)
 - Insert the plug and release the sleeve. (Fig. 5-15)

- Push plug until the sleeve snaps forward, locking the plug into the socket. (Fig. 5-16)
- Turn handle to “ON” position to turn gas on. (Fig. 5-17)



Fig. 5-13

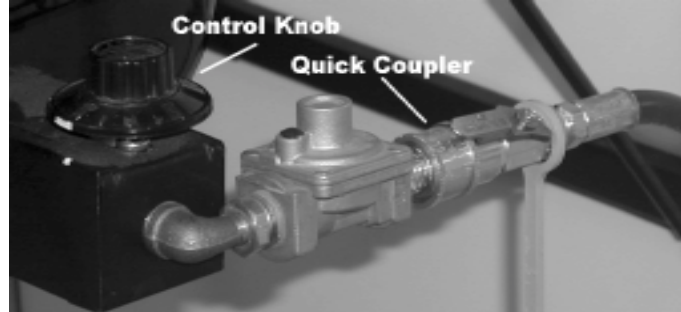

Fig. 5-14

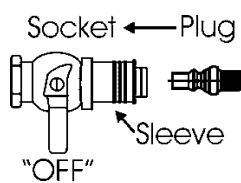

Fig. 5-15

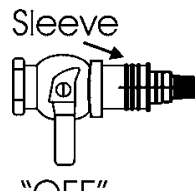

Fig. 5-16

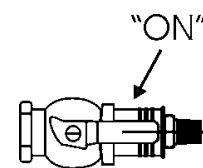

Fig. 5-17

4. Open the lid to the BBQ Grill.
5. Using an electric match, light the grill using the following procedures:
 - Light the electric match.
 - Insert it into the middle slot on the bottom of the BBQ Grill.
 - On the grill control knob (Fig. 5-14), depress and turn the knob to the desired temperature.
 - The grill should light at this point.
6. If the grill does not light, turn the gas off, wait five minutes and repeat the above steps.
7. Use the temperature control knob to adjust the grill to the desired temperature.

The BBQ Grill grate is coated with standard grill enamel and can be cleaned as you would a grill at home. Underneath the grate, there is a heat defuser. This is formed and ventilated to distribute the heat from the burner. Do not use lava rocks in this grill.

To disconnect the BBQ grill, turn the temperature control to the “OFF” position. Reverse the above fuel hose hookup procedures. Wait until the grill is completely cooled, and then store it in the supplied carrying case. This carrying case will ONLY accommodate a cool grill. The grill carrying case has a pocket for accessories such as the fuel hose in the lid. The bracket will not fit inside the carrying case and will need to be stored in a separate location.

CAUTION: The BBQ grill must be COMPLETELY cooled before storing to avoid damaging the carrying case.

CHAPTER 6

CARE OF BODY COMPONENTS

EXTERIOR ALUMINUM

Your new Jayco travel trailer has an improved smooth metal with a new polyester automotive paint finish. This metal surface may be cleaned and polished as you would your automobile.

CAUTION: We do not recommend you take your recreation vehicle through automatic car washes and extreme caution should be used if utilizing any type of pressure sprayer around all attachments, doors, windows, appliance vents, etc. to avoid forcing water inside the unit, possibly damaging components.

FIBERGLASS SIDEWALLS

Fiberglass walls are very durable and are easy to maintain. To keep them looking nice, wax and buff them once a year. Standard automotive cleaning soaps and waxes work well for general cleaning and maintenance. In addition, do not dry wipe surface. Special cleaners and waxes are available at automotive and RV stores.

Scratches and chips can be easily fixed by an experienced fiberglass repair shop. Any major damage should be repaired as soon as possible to keep cracks from spreading.

EXTERIOR ROOF

Two different types of roof material are used on Jayco campers; rubber EPDM or mill-finished aluminum.

Aluminum - The roof is smooth mill-finished aluminum and needs very little maintenance. For washing aluminum material, use a mild detergent soap and water solution. Rinse well after washing. Rinse the sidewalls completely to remove streaking.

Rubber - To keep material looking its best simply wash and clean with a sponge, water, and non-abrasive common household detergent. For stubborn stains use a kitchen cleanser with bleach. Do not allow the solvent to soak into the rubber material.

CAUTION: All roofs require maintenance. At least once per year, inspect and reseal all seams: front and rear, around all vents, and along all moldings. If you notice any deterioration in the seal, scrape off any cracked or loose sealant and then reseal the area.

All corners or flat trim have putty tape sealer between the trim and aluminum skin. This sealant can be damaged by weather elements for cracking and dry-out conditions. Clean the edges and cap seal the edge of molding and skin surface, using sealant recommended by your dealer. This process should be done at least once per year.

STONE GUARD

Wash the stoneguard with liquid dishwashing soap or liquid car washing soap and water. Do not use powdered detergent, powdered soap, liquid and spray cleaners or pressure washing. Wax frequently to protect the surface and make cleaning easier.

ABS PLASTICS

ABS plastic components such as shower walls, tubs and exterior fenders will retain their original beauty with reasonable care.

For cleaning:

1. Dust and wipe clean with soft, damp cloth or chamois, wiping gently.
2. Wax or polish with Simoniz,[®] Aero-Wax,[®] or Glo-Coat[®] using flannel or jersey cloth. After polishing, wipe gently with damp cloth to ground electrostatic charges which may attract dust particles.

DO NOT use gritty or abrasive particle soaps or scouring compound to clean ABS plastic.

| |
|---|
| CAUTION: Avoid using "Citrus" or biodegradable cleaners which contain "D-Limonene." They will damage plastic materials. |
|---|

FRAME

The frame of your Jayco recreation vehicle is painted with a water based paint. Road debris will chip the paint, inviting rust and other deterioration. Periodically inspect the exterior exposed areas, clean and repaint the steel members to insure a long life. If damage would occur, the frame needs to be painted with e-coat paint and not a gloss black paint. This type of paint is available in a spray from the vendor, Leland. To prevent rust or corrosion, you may wish to purchase a commercially available rust treatment application.

DOORS, EXTRUSIONS, WINDOWS & VENTS

These components have putty tape between the component and the wall surface. Portions of these items may have a cap seal added as a secondary seal. Inspect these seals at least once per year. Both putty tape and cap seals can become damaged by U.V. exposure, air pollution, freezing temperatures and exposure to the elements.

Locks on entrance and baggage doors need biannual lubrication. Silicone lubricant is recommended. Conditions such as rain, salt, dust and pollution may increase the maintenance needs.

FURNITURE

For Cloth Furniture: vacuum occasionally to remove dirt, dust and pet hair. Have steam cleaned when necessary. Test fabric in an inconspicuous location before using any spot cleaners.

For Synthetic Leather: wipe with a soft damp cloth for most dirt and spills, air dry. If needed, use a small amount of a mild liquid detergent. For oil or grease stains, spray immediately with an all-purpose spray cleaner or Tannery Car Care Cleaner. Take care not to smear beyond the original stain. Rinse with clean water, air dry.

To Operate Sofa/Recliner Footrest:

1. Make sure cushion is clear of the footrest opening.
2. Place heels over the edge of the footrest and pull towards you to release the safety lock.
3. Push down – DO NOT FORCE.

CUSHIONS

CAUTION: Do not dry clean vinyl components. Do not remove covers for dry cleaning.

If the cushions are dry cleaned, the vinyl on the reverse side of the cushion will shrink, become hard and crack. Vacuum the fabric and wipe the vinyl surfaces. The fabric can be gently steam cleaned on the cushions or mats if necessary.

All dinette and bed mat covers are treated with stain protector. Vacuum the cover with a brush attachment periodically to remove dirt.

BEDSPREADS

Dry clean only.

WINDOW TREATMENTS

The window treatments of your recreation vehicle may include mini blinds, pleated shades, and/or drapes. Refer to the following guidelines for cleaning.

| Window Treatment | Light Cleaning | Extensive Cleaning |
|-------------------------------|-----------------------|---|
| Mini Blinds | Dust or Vacuum | May be removed and washed with a mild detergent and warm water. |
| Pleated Shades | Vacuum | A professional dry cleaning service is recommended. |
| Privacy or Cab Area Draperies | Vacuum | Professionally Dry Clean |

CAUTION: To prevent scorching of the window shades, do not use the swivel arm lamps located adjacent to the slideout if one of the lampshades is broken or missing. Remove the light bulb and contact a qualified service center for repairs or replacement.

SHOWER CURTAIN AND LINER

The shower curtain is made of a cotton or cotton/polyester material and should be dry cleaned. The shower curtain liner should be cleaned as you would clean your own shower curtain liner at home.

TIRE COVERS - VINYL (Optional)

To minimize the possibility of the tire “bleeding” through onto the tire cover, use a separator (garbage bag, paper cloth, etc.) between the tire and cover.

PANELING

The wall paneling in your travel trailer is a vinyl covered wood panel. If deep scratches occur, putty sticks can be used to cover them. These can be obtained from hardware stores and lumber yards. For decor paneling, replacement vinyl covering can be purchased for repairs if needed. Your dealer's parts department can assist you with this.

To clean, use a mild solution of soap and lukewarm water with a soft sponge or cloth. **DO NOT** use abrasive cleaners. It could cause the vinyl to scratch and turn dull. Grease spots and stubborn dirt can be cleaned off with an all-purpose spray cleaner. Harsh cleaners and organic solvents can attack the printed vinyl and, therefore, are not recommended.

VINYL FLOOR

To care for the vinyl floor covering, use a damp mop with water and a mild cleaner. **DO NOT SOAK FLOORING**. Use care to avoid wetting carpet edges.

WOOD FLOOR

Use a cleaner formulated for wood floors.

BATHROOM TUBS, LAVATORY SINKS

The bath tub in your Jayco travel trailer is made of ABS plastic material. **DO NOT** use abrasive type cleaners, as they may scratch surfaces. Use a mild detergent soap and warm water to clean the tub surface. These cleaning instructions are similar to those recommended for fiberglass tubs and walls. For any type of repair work, see your authorized Jayco dealer.

CARPETING

If your travel trailer contains carpeting, vacuum frequently. Professional steam cleaning for tough and deep stains is recommended. Use spot removers for minor spills. **ALWAYS TEST CARPET FOR COLOR FASTNESS** in an inconspicuous area before using any product.

NOTE: Avoid chemical cleaners. **DO NOT** permit cleaners to touch carpet or fabrics.

COUNTERTOPS

Made of high pressure laminate, the countertops are easy to keep clean. Glass rings, food spills, water spots and smudges usually wipe off with a damp sponge. Stubborn stains can be removed with a general purpose spray cleaner. Some stains can be removed by squeezing fresh lemon juice over the stain and allowing the juice to soak for approximately forty-five minutes. After forty-five minutes, sprinkle baking soda over the lemon juice and rub with a soft cloth.

HARDWARE AND SINK OR SHOWER FIXTURES

Use mild dish soap and water to clean these fixtures. Never use harsh chemicals or sprays. A mild solution of vinegar and water works well to remove hard water spots and stains from the sink or shower fixtures.

CHAPTER 7

MAINTENANCE/STORAGE

Your new Jayco travel trailer is designed to be as maintenance free as possible. However, maintenance is important to retain its condition as near new as possible. Proper maintenance will give you many trouble-free miles.

NOTE: Some areas in this chapter may not be applicable to your coach.

SLIDEOUT

Your Power Gear slideout system has been designed to require very little maintenance. To ensure a long life of your slideout system, read and follow these simple instructions.

CAUTION: Do not work on your system unless the battery is disconnected.

- When the slideout is extended, visually inspect the inner slide rail assemblies (Fig. 3-6 in Chapter 3). Check for excess build-up of dirt or other foreign material; remove any debris that may be present.
- If the system squeaks or makes any noise, apply a coat of lightweight oil to the drive shaft and roller areas. (Fig. 3-6 in Chapter 3) Remove excess oil so dirt does not build-up.
- On travel trailers with a flush floor slideout, a light coat of silicone spray is recommended one time per year. To apply the spray, lift the carpet flap. Using a light coat of spray, make one pass all along the glide bar. It is recommended that this be done prior to each camping season.

CAUTION: Use only a silicone spray to lubricate the glide bar. Other lubricants may attract dirt and oils which will stain the carpet.

- If you have any problems or questions consult your local Jayco dealer or call Power Gear 1-800-334-4712.

CARBON MONOXIDE DETECTOR

Testing

WARNING: DO NOT attempt to test the detector by any other means than using the “test” button. DO NOT attempt to produce carbon monoxide to test the detector.

The CO detector should be tested weekly for proper operation:

1. Push the test button until the yellow LED lights and a short beep is heard for approximately three seconds.
2. Release button.

The detector will test itself for proper operation. Upon completion of the self-test, the alarm will sound and each of the LEDs will light for approximately $\frac{3}{4}$ second. The detector will then resume normal operation.

Battery Replacement

Under normal operating conditions, the battery will last approximately one year. The detector has a low battery monitor circuit which will cause the detector to make a chirping sound then the red LED to flash every 30-40 seconds for a minimum of seven (7) days indicating the battery is low. Replace the battery when this occurs. Use only 9-volt batteries for the CO detector.

WARNING: Use only the batteries specified for replacement. Use of different batteries may have a detrimental effect on the CO detector.

Cleaning

Use the following procedure to clean the CO detector:

1. Remove the detector from the mounting plate by rotating the detector in the direction of the “OFF” arrow on the cover.
2. Clean the interior of the detector by using a vacuum cleaner hose and vacuuming through the openings around the perimeter of the detector.
3. Wipe the outside of the detector with a damp cloth.
4. Replace the detector back onto the mounting plate.
5. Test detector using the testing procedure.

Unit Replacement

The CO detector should be replaced every six years.

TV ANTENNA

Lubricating the Elevating Gear (Fig. 7-1)

The elevating gear will need to be lubricated with a liberal amount of silicone spray. To lubricate, apply the silicone to the elevating gear with the lift in the down position then run the lift up and down a few times to distribute the lubricant over the gears.

Lubricating the Bearing Surface (Fig. 7-2)

Twice per year or when rotation of the antenna becomes difficult, lubricate the bearing surface between the rotating gear housing and the base plate with silicone spray. Elevate the antenna and remove the set screw or plastic plug from the rotating gear housing. Spray the silicone into the hole and around the edges of the gear housing. Rotate the gear housing until the lubricant coats the bearing surface and the antenna rotates freely.

Lubricating the Rubber Quad Ring (Fig. 7-3)

Lubricate the rubber quad ring located on the elevating shaft below the worm gear with silicone spray at least twice per year to prevent the quad ring from becoming brittle resulting in leaks in the elevating shaft. Refer to the vendor’s owner’s manual for information regarding removal of the worm gear assembly.

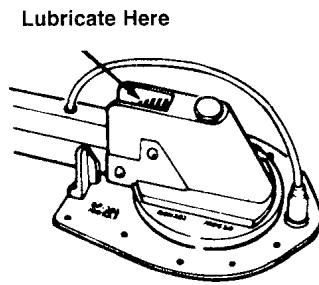

Fig. 7-1

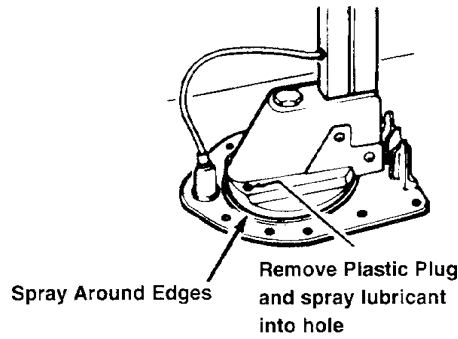

Fig. 7-2

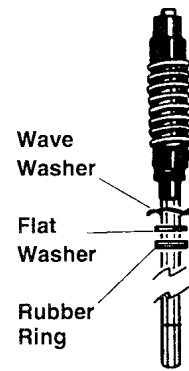

Fig. 7-3

FURNACE MAINTENANCE

Preventive maintenance and safety checks should be performed by a qualified technician once a year, or more, depending on the use of the furnace. **Failure to properly maintain the furnace may void the furnace warranty and can result in unsafe furnace operation. Preventive maintenance is NOT covered under the warranty. Power should be disconnected before servicing.**

NOTE: To increase motor life, the furnace should be wired directly to the battery.

TOILETS

Aqua Magic® Starlite/Galaxy/Aurora

No routine maintenance is required. To clean toilet, use a high grade, non-abrasive RV toilet bowl cleaner. Do not use highly concentrated or high acid content household cleaners or scouring powder, as these products can damage seals and finish. Do not use products with chlorine or bleach.

Aqua Magic® 4

The Aqua Magic® 4 does not require routine maintenance except for cleaning. In some installations the seat and cover can be removed to facilitate cleaning. To remove seat, both seat and cover should be in the open (up) position. Grasp assembly on both sides and pull away from you in an upward angle of approximately 45°. To reinstall seat and cover, place legs of assembly in rear slots of cover until they are centered on hinge posts and gently push down at approximately 45° until you feel the engagement.

STORAGE

Depending upon your area and where your unit is stored, your camper may be a target for damage from rodents and insects. To protect your camper, never leave food inside the unit and ensure that all surfaces are clean. You may want to place rodent control products in the unit during periods of storage. Mice can do a tremendous amount of damage to the tent, drapes, cushions, etc. particularly during the winter months. Storing units in fields make them particularly inviting to rodents. Periodically inspect your unit during storage and seal off any areas which can offer an entry point to rodents or insects. Please remember to remove any screens or tape you have used to seal openings before you use the camper again. Special interest publications, such as articles and books offered through TL Enterprises (Trailer Life, Motorhome, etc.) can offer additional and practical advice on the proper storage of your camper. Damage from rodents or insects are NOT covered under your Jayco Limited Warranty.

CAUTION: When storing your travel trailer, it is recommended that the battery be unhooked to avoid draining the battery.

LP GAS BOTTLES

1. The LP gas bottle or tank must be painted with a light color, such as white or silver plate, to reflect heat and light.
2. Rust, scratches, and/or dents can affect the safety of the bottle or tank. The D.O.T. requires that a visual inspection is made prior to each filling.
3. Any container that has been exposed to fire, leaks or seems damaged should not be refilled.
4. An LP bottle must always be placed in an upright position. Assure that the bottle is secured in place prior to moving the vehicle.
5. The D.O.T. requires that LP bottles be inspected, certified and labeled when it is twelve years old. (The number of years for certification may vary in your area.) Following the initial twelve-year period, the bottle must be certified every five years.
6. The valve of the bottle or tank must be **CLOSED** at all times except when it is connected to the recreation vehicle LP gas system or is being refilled.
7. Inspect the bottle at regular intervals. If there is a problem, have it evaluated by a qualified technician and discard it, if necessary. Verify with your local LP dealer that all required inspections and certifications have been completed on the LP bottle within the correct time period before refilling the bottle.

STORAGE

Depending upon your area and where your unit is stored, your camper may be a target for damage from rodents and insects. To protect your camper, never leave food inside the unit and ensure that all surfaces are clean. You may want to place rodent control products in the unit during periods of storage. Mice can do a tremendous amount of damage to the tent, drapes, cushions, etc. particularly during the winter months. Storing units in fields make them particularly inviting to rodents. Periodically inspect your unit during storage and seal off any areas which can offer an entry point to rodents or insects. Please remember to remove any screens or tape you have used to seal openings before you use the camper again. Special interest publications, such as articles and books offered through TL Enterprises (Trailer Life, Motorhome, etc.) can offer additional and practical advice on the proper storage of your camper. Damage from rodents or insects are NOT covered under your Jayco Limited Warranty.

CAUTION: When storing your travel trailer, it is recommended that the battery be unhooked to avoid draining the battery.

LP GAS BOTTLES

1. The LP gas bottle or tank must be painted with a light color, such as white or silver plate, to reflect heat and light.
2. Rust, scratches, and/or dents can affect the safety of the bottle or tank. The D.O.T. requires that a visual inspection is made prior to each filling.
3. Any container that has been exposed to fire, leaks or seems damaged should not be refilled.
4. An LP bottle must always be placed in an upright position. Assure that the bottle is secured in place prior to moving the vehicle.
5. The D.O.T. requires that LP bottles be inspected, certified and labeled when it is twelve years old. (The number of years for certification may vary in your area.) Following the initial twelve-year period, the bottle must be certified every five years.
6. The valve of the bottle or tank must be **CLOSED** at all times except when it is connected to the recreation vehicle LP gas system or is being refilled.
7. Inspect the bottle at regular intervals. If there is a problem, have it evaluated by a qualified technician and discard it, if necessary. Verify with your local LP dealer that all required inspections and certifications have been completed on the LP bottle within the correct time period before refilling the bottle.

MECHANICAL MAINTENANCE CHART

| COMPONENT | MAINTENANCE | AVOID |
|----------------|--|--|
| Wheel Bearings | <p>The wheel bearings in your new Jayco travel trailer are pre-greased. It is recommended that you repack these bearings at 12,000 miles (19,000 kilometers) or at the end of each season's camping to prepare for the winter months ahead.</p> <p>Use only a multipurpose No. 1 or 2 good quality wheel bearing grease.</p> <p>If the bearing or cone (race) become pitted, replace any damaged part.</p> <p>NOTE: Should you be concerned about heat in the wheel bearings, check them occasionally while traveling by placing your hand on the hub. You will be able to hold your hand momentarily on the hub.</p> <p>Should it be extremely hot, it is recommended to have the bearings inspected by a qualified service center.</p> <p>NOTE: During the break-in period (first 500 miles) (800 kilometers) your hubs may feel extra warm due to brake shoes setting in with the brake drum.</p> | <p>Exposure to any water or condensation will cause the bearings to rust and be damaged.</p> <p>Never let the bearings run dry.</p> <p>Never overpack the wheel bearing, especially in the middle of the hub. It will trap heat and possibly disperse grease from the seals or dust cap.</p> |

| COMPONENT | MAINTENANCE | AVOID |
|-------------------|---|---|
| Lug Nuts | <p>Lug nuts must be checked at 10, 25 and 50 miles (15, 40 and 100 kilometers) when your travel trailer is new or a tire is removed and every 3,000 miles (5000 kilometers) thereafter. In addition, the lug nuts should be checked periodically for safety, especially before long trips, extensive braking, or tire changes.</p> | <p>DO NOT ignore checking wheel lug nuts.</p> |
| Coupler | <p>Tighten the lug nuts to 90-120 ft. pounds torque using a cross tighten sequence: 5 stud = 1-3-5-2-4; 6 stud = 1-4-2-5-3-6; 8 stud = 1-5-3-7-2-6-4-8.</p> <p>Use a small quantity of lubricant on the moving mechanism and all points of movement in the actuator to insure ease of operation.</p> <p>Use conventional grease on the hitch ball for ease of operation.</p> | |
| Fifth Wheel Hitch | <ul style="list-style-type: none"> • Inspect all joints and links for tightness to prevent loss. Design is such that bolts and nuts can be tight and still function properly. • Lubricate all moving parts of fifth wheel for proper operation. • Grease top surface of wheel to eliminate wear and facilitate easier turning. • Before coupling to trailer, inspect all moving parts of fifth wheel. Replace all bent or worn parts. • Thoroughly inspect unit every 1,000 miles (1600 kilometers). • Ensure that all installation bolts and nuts are tight. | |

| COMPONENT | MAINTENANCE | AVOID |
|--------------------------|---|--|
| Tongue Jack | Lubricate the jack by extending to full down position and insert SAE 30 oil through oil hole in top of jack. Do this several times per season. | |
| Fifth Wheel Landing Gear | <p>Inspect pad and inner ram periodically.</p> <p>Apply silicone spray to the inner tube, pad and inside of handle alignment tube yearly.</p> <p>Grease gears in the gear box and at the top of each leg with extreme pressure grease yearly.</p> <p>Oil the shaft bushings with SAE 30 oil yearly.</p> <p>Clean electrical connections with baking soda, then cover with a thin coat of grease twice a year.</p> | <p>Excessive quantity of grease.</p> <p>Excessive oil will run and attract dirt.</p> |
| Tires | It is very important to check tires often as noted in Chapter 3. | DO NOT ignore checking tire pressures often. |
| Change Tire & Wheel | <p>To raise coach, place jack (hydraulic or screw) underneath main frame rail, which spans from front to rear, just inside of tires. Use jack stands or solid-blocking for safe support. Place jack just ahead of front tire or just behind rear tire.</p> <p>You may wish to loosen (only) lug nuts before raising coach. Remove lug nuts after tire clears ground.</p> | Never raise the travel trailer by placing the jack under the axle beam, springs or any attachment parts. |

| COMPONENT | MAINTENANCE | AVOID |
|---------------|--|--|
| Brakes | <p>It is important to have brakes adjusted between 200-1,000 miles (320-1600 kilometers) after initial break-in period by a qualified technician. This operation may or may not be included as part of selling price.</p> <p>After the initial break-in period, you should adjust the brakes after each 3,000 miles (4,800 kilometers) or at the beginning of each season's camping trips.</p> | <p>It is very important to keep brakes adjusted. Poorly adjusted brakes will not function correctly. Under adjustment can cause an adjuster wheel to fall out.</p> |
| LP Gas System | <p>Beginning of each camping trip:</p> <ol style="list-style-type: none"> 1. Inspect all gas lines for crimps and road damage. 2. Check all lines and connections for leakage with soapy water or leak detector. 3. Have the regulator checked and adjusted to the proper pressure once per year by a qualified dealer. | <p>DO NOT smoke while changing bottles or any lines.</p> <p>DO NOT allow connections to be loose.</p> |
| Appliances | <p>To care for brushed chrome it is recommended to clean with a mild soap and water. Wipe dry with a soft cloth. Apply a light coat of oil such as baby oil periodically.</p> <p>Various items on these appliances need to be cleaned periodically as need be, such as burner orifices, etc. See individual booklets for directions or see your dealer.</p> | <p>DO NOT use steel wool, ammonia, acids, or abrasives on chrome surfaces.</p> |

| COMPONENT | MAINTENANCE | AVOID |
|---------------|---|--|
| Sealants | <p>All sealants used in construction can deteriorate from U.V. exposure, air pollution, freezing temperatures and other exposure to weather elements.</p> <p>Tape sealants used around doors, windows, and extrusions are subject to dry out conditions by sunlight and will allow water seepage when they deteriorate.</p> <p>Inspect sealants at least two times each year and look for voids and/or dried out cracking or peeling conditions. See Fig. 7-4 or 7-5. Reseal as necessary or at least one time each year. Contact your dealer for the appropriate sealant to use.</p> | <p>Using poor quality sealing material.</p> <p>Failure to reseal sealant and putty tape.</p> |
| Entrance Door | <p>Inspect and seal corners of the door frame threshold one time each year. See Fig. 7-4 or 7-5.</p> | |
| Roofs | <p>All roofs require maintenance. At least two times each year, inspect all seams: front, rear, around all vents, and along all moldings for voids, lifting, peeling or cracking. Reseal as necessary or at least one time each year. If you notice any deterioration in the seal, scrape off any cracked or loose sealant and then reseal the area. See Fig. 7-4 or 7-5.</p> | <p>Not resealing once per year.</p> |

INSPECTION POINTS FOR SEALING

Fig. 7-4
Conventional Travel Trailer

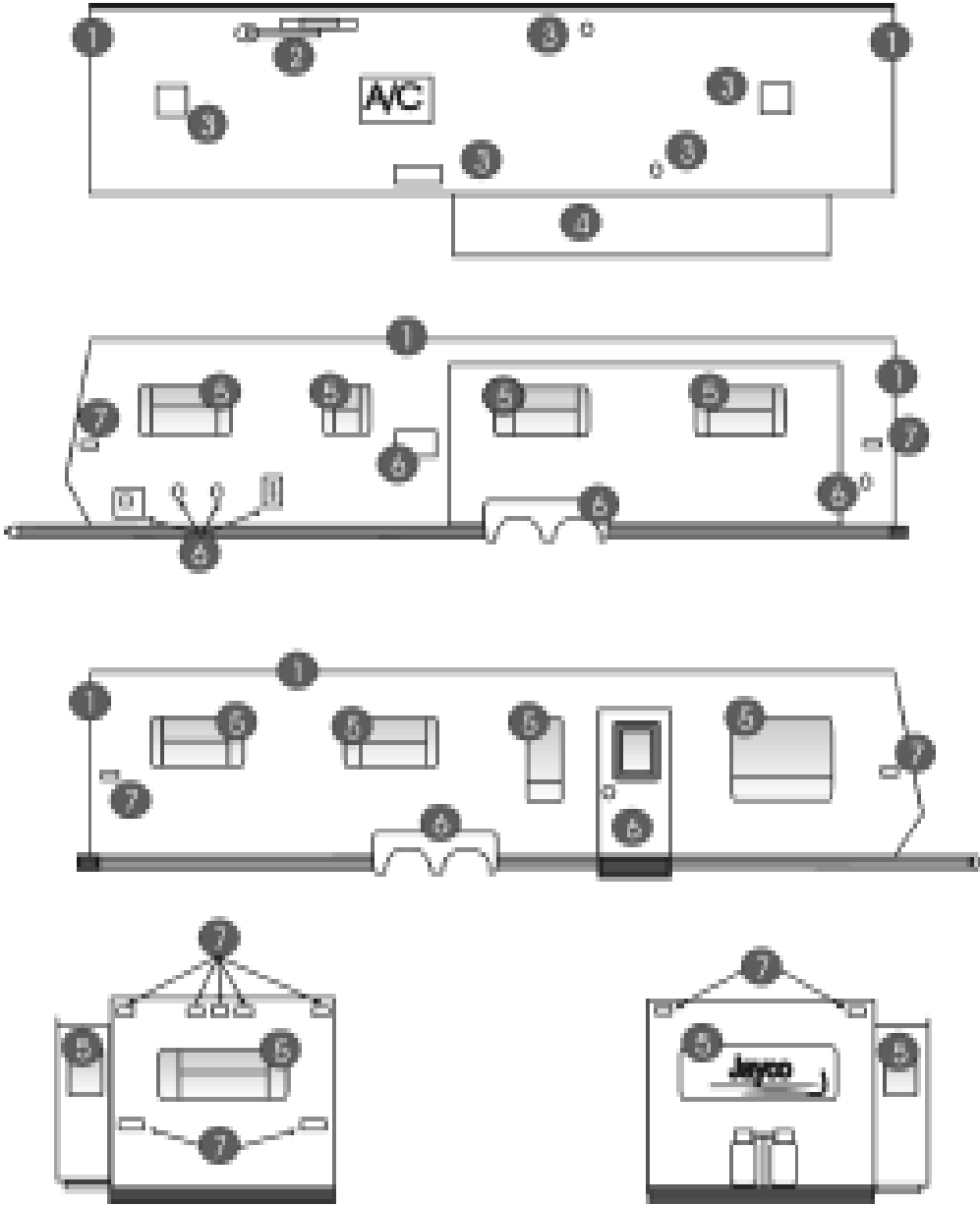

- | | |
|---------------------------|-------------------------|
| 1. Moldings | 5. Windows |
| 2. TV Antenna | 6. Exterior Attachments |
| 3. Vents | 7. Marker & Tail Lights |
| 4. Slideout Trim/Moldings | |

Fig. 7-5
Fifth-Wheel Travel Trailer

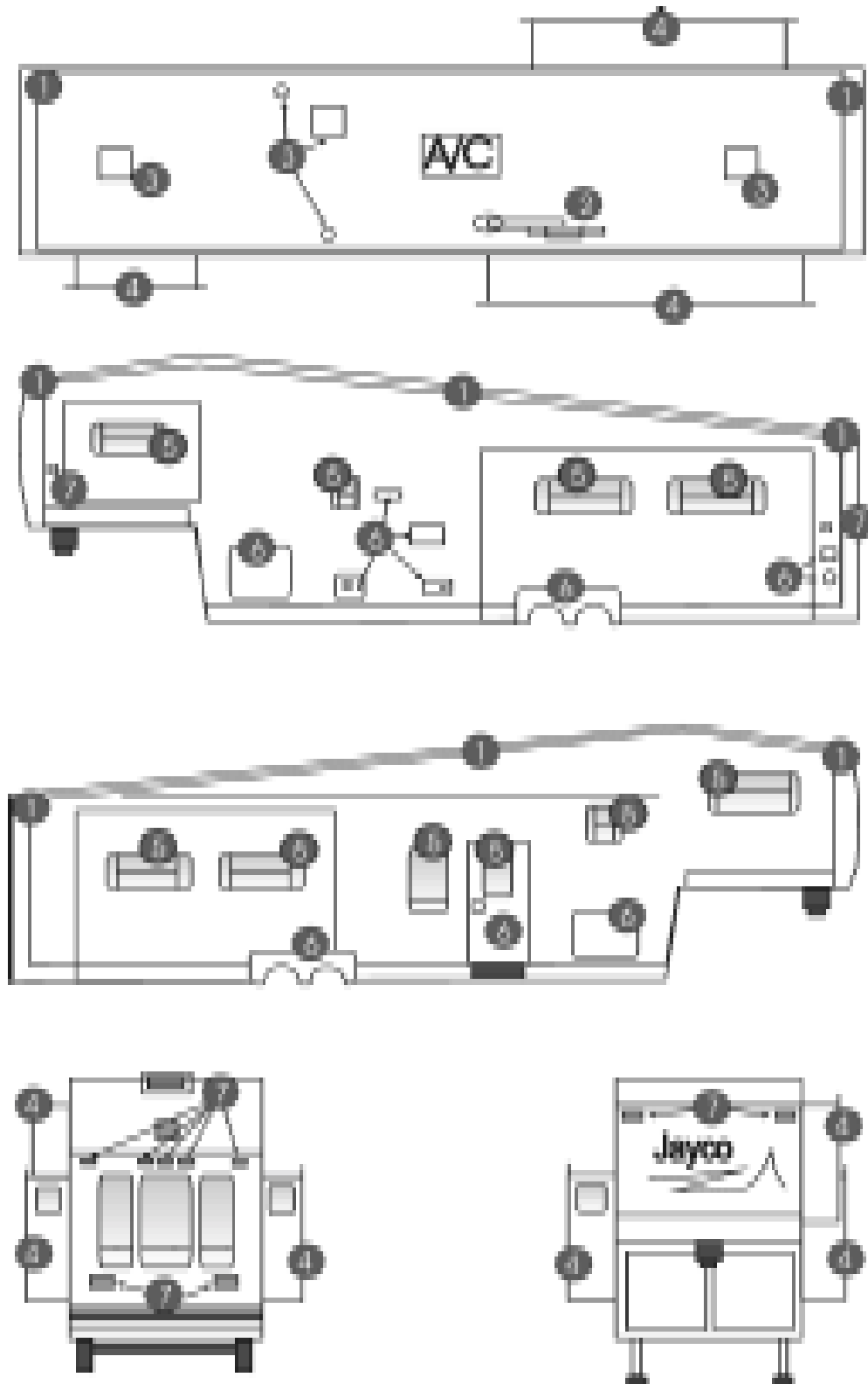

- 1. Moldings
- 2. TV Antenna
- 3. Vents
- 4. Slideout Trim/Moldings

- 5. Windows
- 6. Exterior Attachments
- 7. Marker & Tail Lights

MAINTENANCE CHECKLIST

Prior to First Trip

- Check LP gas lines for leaks.
- Test carbon monoxide detector (Generator/Generator Prep option only.)
- Test LP gas detector.
- Sanitize fresh water system.
- Tighten wheel nuts to specified torque values.
- Open all windows and the door and start the furnace. Leave the windows and door open and the furnace on until all fumes fully dissipate.

First Ten Miles

- Tighten wheel nuts to specified torque values.

First Twenty-Five Miles

- Tighten wheel nuts to specified torque values.

First Fifty Miles

- Tighten wheel nuts to specified torque values.

First Two-Hundred Miles

- Tighten wheel nuts to specified torque values.
- Have brakes adjusted by a qualified service technician.

Each Trip

- Test LP gas detector.
- Check battery water level. (If equipped with battery.)
- Check brake fluid level in master cylinder reservoir. Keep filled to within ½” from top of reservoir.
- Check master cylinder cap for tightness.
- Check tire pressure and wear.
- Check running lights.
- Inspect safety chains for signs of wear.
- Test brakes.

After Every Tire Change

- Tighten wheel nuts to specified torque values at ten miles, twenty-five miles and fifty miles.

Daily

- Recharge battery after each use.
- Ensure LP gas detector operation light is green in color.

Weekly

- Test LP gas detector.
- Check tire pressure and wear.

Monthly

- Clean and lubricate the coupler.
- Check fire extinguisher pressure. Do not test the extinguisher.
- Test the ground fault circuit interrupter (GFCI)

Every Three Months or 3,000 Miles

- Vacuum around L.P. Burner and pilot light areas.
- Compare water heater pilot flame with ideal flame. Refer to the water heater owner's manual for ideal flame. Clean and adjust as necessary.
- Compare refrigerator pilot flame with ideal flame. Refer to the refrigerator owner's manual for ideal flame. Clean and adjust as necessary. (RV type refrigerator only)
- Inspect refrigerator door seals.
- Inspect refrigerator combustion seals. (RV type refrigerator only)
- Check LP gas lines for leaks.
- Inspect LP cylinders for rust, pits, gouges, scrapes or sharp dents. Repaint cylinders if rust is present.
- Drain and sanitize fresh water system.
- Check, clean, tighten and lubricate battery cables.
- Tighten wheel nuts to specified torque values.
- Examine the tires for unusual wear, sidewall defects, cuts, wear, bulging and abrasions.
- Lubricate tongue jack.
- Lubricate hitch ball.
- Have breaks adjusted by a qualified service technician.

Every Four Months or 4,000 Miles

- Flush out water heater tanks.

Every Six Months or 6,000 Miles

- Clean drains with approved drain cleaners.
- Check pipe connections for tightness. Tighten if necessary.
- Lubricate all moving parts on the entrance steps.
- Lubricate entrance and baggage door locks.
- Clean and lubricate stabilizer jacks.
- Inspect wheels for cracks, dents or distortion.
- Inspect and reseal all sealant and putty tape.
- Have suspension system serviced by a qualified service technician.
- Lubricate the elevating gear on the television antenna.
- Lubricate the bearing surface between the rotating gear housing and the base plate on the television antenna.
- Lubricate the rubber quad ring on the elevating shaft located on the television antenna.
- Clean fifth-wheel landing gear electrical connections with baking soda, then cover with a thin coat of grease.

Every Year or 12,000 Miles

- Repack wheel bearings.
- Lubricate moving parts on the awning hardware. (Awning option only.)
- Oil drive shaft bearings.
- Manually operate the pressure-temperature control lever or dial to the lowest possible position on the water heater.
- Clean city water entry strainer.
- Check demand tank vent for obstructions.
- Check water pump connections and mountings for tightness.
- Vacuum the LP gas detector cover.
- Rotate Fluorescent tubes in the light fixtures. (XL package only.)
- Clean absorption refrigerator flue. (RV type refrigerator only)
- Replace battery on the carbon monoxide detector (Generator/Generator Prep option only.)
- Have LP gas system inspected and serviced by a qualified technician.
- Inspect and seal corners at the threshold of the entrance door.
- Have the refrigerator inspected and serviced by a qualified technician.
- Have brakes inspected and serviced by a qualified technician.
- Have furnace inspected and serviced by a qualified technician.
- Apply silicone spray to the fifth-wheel landing gear inner tube and pad and the inside of the handle alignment tube.
- Grease gears in the gear box and at the top of each leg of the fifth-wheel landing gear with extreme pressure grease.
- Oil the shaft bushings of the fifth-wheel landing gear with SAE 30 oil.

Every Six Years

- Replace carbon monoxide detector (Generator/Generator Prep option only.)

CHAPTER 8

OPTIONS

Note: Each item listed in this chapter is an option as the travel trailer is built by Jayco.

AIR CONDITIONER

Air conditioners may be installed by the Jayco factory or by your dealer. If you did not buy your camper with the optional air conditioner, one of your roof vents may be pre-wired for later installation. Your dealer can provide you with additional information concerning this.

There are a variety of air conditioners available. For specific instructions for the air conditioner, consult your dealer and the manufacturer's owner's manual.

Some models have Central Air Conditioning available. All cooled air is moved through a duct built into the roof and enters the travel trailer through a group of round registers.

Keep all registers open to insure full airflow. Closing the register(s) may cause the compressor to freeze, which could shut down the cooling process.

A special foam gasket is placed between the roof material and the subframe of the air conditioner to guard against water leakage.

An air conditioner is subjected to wind pressures along with motor vibration during normal operation. Annually inspect the mounting bolts for tightness to ensure there is no leakage or looseness. Retighten bolts when they are loose. **DO NOT** overtighten these bolts as it may damage the gasket.

To gain access to the bolts, remove the filtered panel cover on central air systems or the entire air box on non-central air conditioners.

| |
|---|
| <p>CAUTION: When camping at campgrounds providing less than 30 amp service, discontinue air conditioning use when using the microwave.</p> |
|---|

GENERATOR

The function of a generator is to supply 120-volt AC power on a limited basis when extended power is not available.

The power to start the generator comes from the auxiliary battery. A start/stop switch is located on a mounting plate with the generator. A remote start switch may be located on the monitor panel in the range hood.

With the exception of simple items such as spark plugs and oil changes, all service work should be done by authorized service centers. Improper adjustments can damage the generator and electrical appliances, and can result in a safety hazard. An authorized service center has trained specialists who know how to keep your generator running safely and reliably.

Refueling Generator

Located in the compartment next to the generator is the generator fuel tank. Follow these instructions when refueling the generator fuel tank.

1. Make sure that the tow vehicle and any open flames are extinguished. All pilot lights, appliances, and their ignitors should be turned off before refueling the generator fuel tank.
2. Unhook the quick disconnect from the generator fuel hose to the fuel tank.
3. Unhook the tie down strap buckle and pull the empty tank from the compartment.
4. Lay the fuel tank flat on the ground.
5. Unscrew the lid to refuel the tank. The fuel hose nozzle **MUST** be in contact with the rim of the fuel tank opening during fueling. Refuel with **UNLEADED** fuel **ONLY**.

WARNING: The fuel tank MUST be lying flat on the ground AND the fuel hose nozzle MUST be in contact with the rim of the tank opening during refueling. There is potential for static charge build up if these instructions are not followed which could ignite the gas fumes.

6. When the tank is filled, return the tank to the compartment.
7. Secure the tank with the tie down strap. Make sure the strap is tight and the tank will not move around in the compartment.

CAUTION: It is important to secure the tank tightly with the tie down strap and make sure the tank will not move around in the compartment during travel.

8. Reattach the fuel quick disconnect to the tank.

WARNING: Do not carry fuel in this compartment unless the generator is hooked up.

MICROWAVE OVEN / CONVECTION OVEN

The microwave oven or convection oven in the unit operate on the same principle as the microwave/convection in your kitchen at home. A separate owner's manual is provided with detailed instructions for its use.

RUBBER ROOF

The heavy-duty rubber roof is durable, does not rattle in the wind, requires no special treatment, reduces black streaks on sidewalls, and can be patched if damaged.

To keep your roof looking its best, simply clean it with a sponge and any nonabrasive, common household detergent. For stubborn stains, use a stronger solvent such as xylene, but take care never to saturate.

If your roof is accidentally torn or punctured, there's no need for expensive repairs. The process is much like patching a tire, but we suggest you contact your dealer or Jayco for more information.

As with all trailer roofs, it should be checked at least once a year at roof vents and around the perimeter for signs of cracked or deteriorating sealant. ALPHA 1015 is the best we have found for roofs. Extend HD works best on horizontal surfaces. Both sealants come in caulking tubes and can be purchased from your Jayco dealer.

RV DIGITAL SATELLITE SYSTEM

The satellite system in the RV is similar to the satellite system in your home. Refer to the detailed instructions provided by the manufacturer for additional information.

SPARE TIRE CARRIER

The following procedures should be used in securing the spare tire in the travel position:

1. Put the steel hoist lift support located on the end of the cable through the rim of the tire. Clips need to seat inside of the hole.

Valve stem of the tire **MUST** be pointed in the down position or away from the bottom of the travel trailer. Reference Figure 8-1.

The hoist will not seat the tire correctly if the valve stem is toward the bottom of the travel trailer. Reference Figure 8-2.

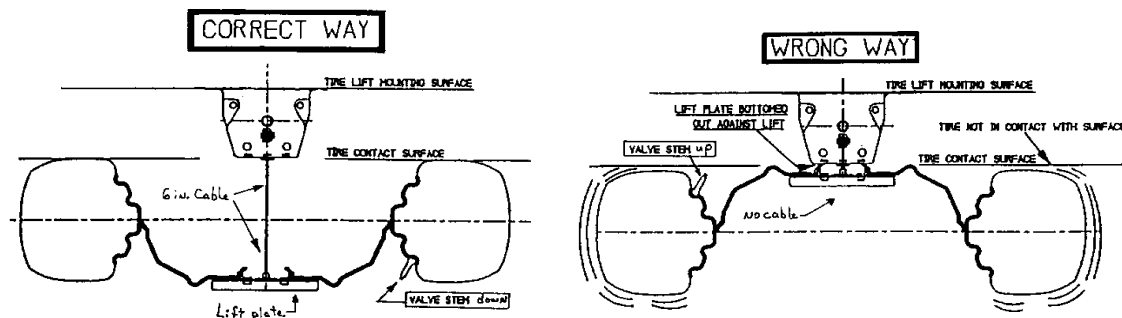

Figure 8-1

Figure 8-2

2. Use the crank handle to lift the tire into the travel position. Two crisp breaks must be heard and felt to insure proper seating of the tire for travel.

The tire must be in contact with the surface to be in the travel position.

WARNING: DO NOT exceed the maximum load capacities of 100 lbs. for the hoist. DO NOT use air driven guns or impact wrenches to lift the tire into travel position.

CEILING FAN

Fifth-Wheel Travel Trailer Option Only

The ceiling fan in the unit operates on the same principle as the fan in your home. A separate owner's manual is provided with detailed instructions for its use.

SECURITY LIGHTS

The security lights can be turned on or off from the entry or bedroom switch.

PATIO DOOR

The patio door must be secured during travel with the four travel blocks supplied by the manufacturer.

CAUTION: Ensure travel blocks are installed prior to travel.

TOWABLE TRANSFERABLE LIMITED WARRANTY

TOWABLE TRANSFERABLE LIMITED WARRANTY

Fold Down, Travel Trailer, Fifth Wheel
Two year limited warranty
Three year structural

SUMMARY OF WARRANTY:

Jayco warrants every Jayco towable recreational vehicle to the first retail consumer and transferee, for a period of two (2) years and three (3) years on the structure from the date of purchase under normal use and service, when used for its intended purpose of recreational travel and camping that all parts of our manufacture are free from substantial defects in material and workmanship. The warranty period shall begin on the date the vehicle is sold to the first retail consumer purchaser or if the dealer prior to sale first places the vehicle in service, on the date the vehicle is first placed in such service.

This warranty may be transferred to the second owner during the warranty period with proper application and a \$100 processing fee.

STRUCTURAL WARRANTY:

Jayco warrants the structure of the interior and exterior sidewalls, floor, roof, and frame to be free of material and manufacturing defects.

EXCLUSIONS:

- (1) Items added or changed after the vehicle left the possession of Jayco.
- (2) Any vehicle used for commercial purposes, or full time residential use.
- (3) Normal wear and usage, such as fading or discoloration of soft goods (tents, upholstery, crates, carpet, vinyl, screens, cushions, mattresses), fading or discoloration of exterior plastic or fiberglass components, tears, punctures, soiling, mildew, effects of moisture condensation inside the vehicle, or mishandling, neglect, abuse, misuse, lightning or other acts of nature, or corrosive air pollutants which can result in rusting, oxidation or pitting.
- (4) Minor imperfections, which do not affect the suitability of the vehicle for its intended use.
- (5) Normal and routine maintenance such as inspections, lubricating, adjustments, tightening of screws, tightening of lug nuts and wheels, sealing, rotting, cleaning, or damages arising from the failure to have maintenance performed as outlined in the owners manual.
- (6) Alignment or adjustments to axles or spindles when caused by improper maintenance, loading or damage from road hazards, including off road travel, wheel damage or balancing, or damage resulting from tire failures.
- (7) Costs incurred for transportation of the vehicle to a Dealer, or costs incurred as the result of the consumer's request to have repairs performed at a location other than an authorized dealership.
- (8) This Limited Warranty does not apply to nor cover any component, which is warranted separately by its manufacturer. Examples are:

*Chassis...Tires...Axles...Wheels... Running Gear Components
Batteries...Appliances...Power Converters...Jacks..*

The written warranty that is provided by the component manufacturer is a direct responsibility of that manufacturer. Jayco makes no warranty as to those components. Please refer to the written warranties issued by such component manufacturers for the terms and provisions of their written warranty undertakings. Warranty information with respect to these items is available from your dealer.

HOW TO OBTAIN WARRANTY SERVICE:

In the event that a defect in materials or workmanship is found to exist in body parts constructed by Jayco, Jayco will bear the cost of the repair or replacement of such defective materials or workmanship; Provided that the owner:

- (A) Notifies an authorized Jayco dealer or Jayco of the defect within 10 days; (If authorized service is not available in your area or other assistance is needed to obtain the benefit of this warranty, please call direct to Jayco 219-825-0670 and ask to speak with someone in the warranty department.)
- (B) Returns the vehicle to a dealer or factory service center promptly, as scheduled; and
- (C) Pays any freight or transportation costs, or import duties or fees involved.

No action to enforce this warranty shall be commenced later than three (3) months after expiration of the warranty period.

NOTE: Jayco, in obtaining repairs, does not control the scheduling of service work at dealerships. You may encounter some delay in scheduling or completion of work.

PURCHASER'S OBLIGATIONS:

Purchaser shall deliver this vehicle for warranty service within a reasonable time after discovery of the defect and in no event later than thirty (30) days after expiration of the warranty period. All incidental and consequential expenses incurred by Purchaser in obtaining warranty service shall be borne by Purchaser. No action to enforce this warranty shall be commenced later than three (3) months after expiration of the warranty period.

DISCLAIMER OF CONSEQUENTIAL AND INCIDENTAL DAMAGES:

You and any other user of Jayco products shall not be entitled to any consequential or incidental damages, including without limitation, loss of use of the unit, inconvenience, lodging, damage to personal property, phone calls, meals, lost income or earnings. This warranty gives you specific legal rights and you may also have other rights, which vary from state to state.

DISCLAIMER AND LIMITATIONS OF IMPLIED WARRANTIES:

Jayco does not authorize any person to create for it any other obligation or liability in connection with this vehicle. Any implied warranty of merchantability or fitness for a particular purpose applicable to this vehicle is limited in duration to the duration of this written warranty. The performance of repairs is the exclusive remedy under this written warranty or any implied warranty. Jayco shall not be liable for incidental or consequential damages resulting from breach of this written warranty or any implied warranty. Some states do not allow limitations on how long an implied warranty will last or the exclusion or limitation of incidental or consequential damages, so the above limitations or exclusions may not apply to you.

PARTS AND DESIGN CHANGES:

Jayco may make parts and design changes from time to time without notice and repairs or replacements may be made with new or different parts. Jayco reserves the right to make changes in the design or material of its products without incurring any obligation to incorporate such changes in any product previously manufactured.

WARRANTY REGISTRATION:

Your warranty registration records should be completed and delivered to the manufacturers of component parts. Your Jayco Dealer will assist you in filling out the warranty registration form, which must be returned to Jayco within 10 days of you taking delivery of your Jayco product. Failure to send this warranty registration to Jayco can cause you delays in obtaining the benefits of your Jayco Limited Warranty.

All inquiries regarding this Warranty should be sent to:

JAYCO, INC.
903 South Main • P.O. Box 400 • Middlebury, IN 46540
Telephone: 219-825-0608

LIMITED WARRANTY TRANSFER APPLICATION



LIMITED WARRANTY TRANSFER APPLICATION

Mail the Jayco, Inc. Limited Warranty Transfer Application, along with transfer fee of \$100.00 payable to:

Jayco, Inc.
Warranty Dept.
P. O. Box 460
Middlebury, IN 46540

**PLEASE READ TERMS AND REPRESENTATIONS
PRIOR TO SIGNING.**

A DEALER INFORMATION

Name _____
Dealer Address 1 _____
Dealer Address 2 _____
Dealer Address 3 _____
City _____ State _____
Zip _____ Phone Number _____

B PRIOR OWNER INFORMATION

Transfer Coverage From:

First Name _____ Last Name _____
Vehicle Identification Number _____

C NEW OWNER INFORMATION

Transfer Coverage To:

First Name _____ Last Name _____
Owner Address 1 _____
Owner Address 2 _____
Owner Address 3 _____
City _____ State _____
Zip _____ Phone Number _____

_____ / _____ / _____ Date of Transfer _____ Odometer Reading at Transfer **MUST BE COMPLETED ON ALL MOTORIZED VEHICLES**

SUBJECT TO TERMS AND CONDITIONS LOCATED ON THE BACK OF THIS FORM

D SIGNATURES

New Owner's Signature _____ Selling Dealer's Signature _____

THE JAYCO, INC. LIMITED WARRANTIES MAY BE TRANSFERRED ONE (1) TIME DURING THE WARRANTY PERIOD WITH THIS APPLICATION AND A \$100 PROCESSING FEE. THE FOLDING CAMPER'S EXTENDED TRANSFERABLE LIMITED WARRANTY MAY BE TRANSFERRED ONE TIME WITHIN THE FIRST TWO (2) YEARS OF OWNERSHIP.

Terms and Representations

By signing your signature(s) on the face side of this form, and in order to induce Jayco, Inc. to transfer its Limited Warranty, you represent the following:

1. That you have received and read a copy of the Jayco Limited Warranty and Owner's Manual.
2. You understand that the unit is to be used only for recreational camping and travel.
3. That all information provided by you on the face side of this form is true and correct.
4. You understand that you are purchasing a pre-owned recreation vehicle and Jayco, Inc. does not make any representation as to its present condition.

NOTES

WELCOME TO THE JAYCO FAMILY!

As the owner of a new Jayco recreational vehicle we are proud to welcome you to our growing family.

All Jayco RV homes are built with care, under the watchful eye of our Quality Assurance program. And it is our sincere wish that you will have a lifetime of fun times with your new Jayco.

We are pleased you chose Jayco and want to do everything possible to make sure you stay as happy with your Jayco RV home as you were on the day you bought it.

We work closely with Jayco dealers to provide customer service for you. We honestly feel that Jayco dealers are on the whole the best in the business. And with nearly 300 of them in the U.S. and Canada you should never be too far from help if you ever need it.



In the months and years to come we hope you'll become a close member of the Jayco family. One way to enjoy your Jayco even more is through our owners club – the Jafari International Travel Club. It's lots of fun and a great way to meet other members of the Jayco family. If you're interested please talk to your dealer about the "flight" in your area. Or write to us directly and we'll be in touch.

From Jayco's family to yours: "Welcome Home!"



903 South Main Street • P.O. Box 460 • Middlebury, IN 46540