

Optimizing GaN performance with an integrated driver



Yong Xie

IC design engineer

Paul Brohlin

Design and system manager

GaN and Next team

High-voltage power solutions

Texas Instruments

Integrating GaN FETs with their drivers improves switching performance and simplifies GaN-based power-stage designs.

Gallium nitride (GaN) transistors can switch much faster than silicon MOSFETs, thus having the potential to achieve lower switching losses. At high slew rates, however, certain package types can limit GaN FET switching performance. Integrating the GaN FET and driver in the same package reduces parasitic inductances and optimizes switching performance. Integrating the driver also enables the implementation of protection features.

Introduction

Gallium nitride (GaN) transistors have switching performance advantages over silicon MOSFETs given their lower terminal capacitances for the same on-resistance and lack of a body diode with reverse-recovery loss. Because of these features, GaN FETs can switch at higher frequencies, improving power density and transient performance while maintaining reasonable switching losses.

GaN devices are traditionally packaged as a discrete device and driven with a separate driver, because GaN devices and drivers are based on different

process technologies and may come from different manufacturers. Each package will have bond wires and/or leads that introduce parasitic inductance, as shown in **Figure 1a**. When switching at high slew rates of tens to hundreds of volts per nanosecond, these parasitic inductances can cause switching loss, ringing and reliability issues.

Integrating the GaN transistor with its driver (**Figure 1b**) eliminates common-source inductance and significantly reduces the inductance between the driver output and GaN gate, as well as the inductance in driver grounding. In this paper, we

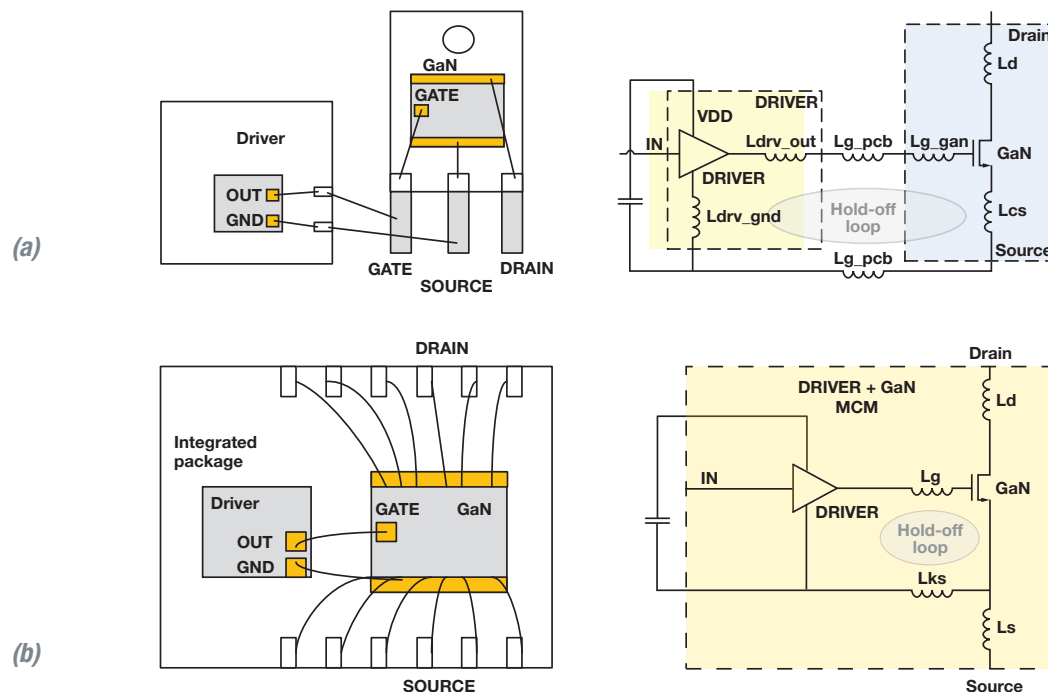

Figure 1. A GaN device driven by a driver in a separate package (a); and an integrated GaN/driver package (b).

will investigate issues and limitations caused by package parasitics. Optimizing these parasitics in an integrated package reduces parasitic issues and enables excellent switching performance at slew rates higher than 100 V/ns.

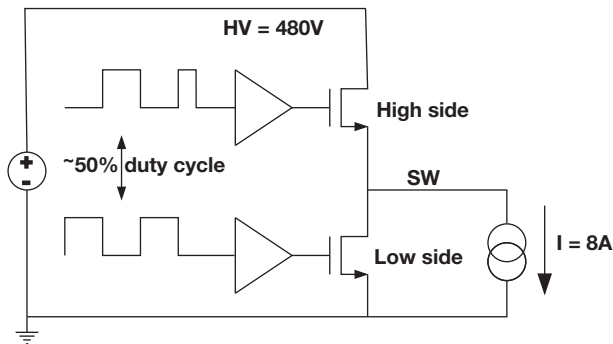

Figure 2. Simplified diagram of the half-bridge circuit for simulations.

Simulation setup

To simulate the effects of parasitic inductances, we used a depletion-mode GaN half-bridge power stage in a direct-drive configuration (**Figure 2**). We set up the half bridge as a buck converter, with a bus voltage of 480 V, a 50 percent duty cycle with 50 ns of dead time (output voltage [VOUT] = 240 V) and an inductor current of 8 A. The GaN gate is directly driven between the on and off voltage levels. A resistive drive sets the turn-on slew rate of the GaN device. A current source emulates an inductive load attached to the switch (SW) node in a continuous-conduction-mode buck converter.

Common-source inductance

One of the most important parasitic elements in high-speed switching is the common-source inductance (Lcs in **Figure 1a**), which limits the slew rate of the device's drain current. In a conventional TO-220 package, the GaN source is brought out through bond wires to a single lead, where both the

drain current and gate current flow. This common-source inductance modulates the gate-source voltage as the drain current changes. The common source inductance – including bond wire and package lead – can be higher than 10 nH, limiting the slew rate (di/dt) and increasing switching losses.

With the integrated package shown in **Figure 1b**, the driver ground is wire-bonded directly to the source pad of the GaN die. This Kelvin source connection minimizes the common-source inductive path shared between the power loop and gate loop, allowing the device to switch at much higher current slew rates. A Kelvin source pin can be added to a discrete package; however, the additional pin makes it a nonstandard power package. The Kelvin-source pin also must be routed on the printed circuit board (PCB) back to the driver package, increasing gate-loop inductance.

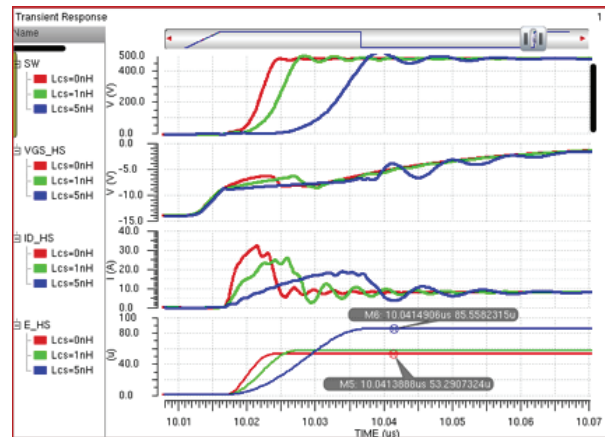

Figure 3. High-side turn on with different common-source inductance: red = 0 nH, green = 1 nH, blue = 5 nH. E_HS is the integration of VDS and IDS of the high-side device over time (energy consumption).

Figure 3 shows hard-switching waveforms when a high-side switch turns on. With a 5-nH common-source inductance, the slew rate is cut in half due to the source degeneration effect. A lower slew rate translates to a longer transition time and leads

to higher cross-conduction losses, as seen in the energy consumption plots. With a 5-nH common-source inductance, the energy loss increases from 53 μJ to 85 μJ , a 60 percent increase. Assuming a 100-kHz switching frequency, the power loss increases from 5.3 W to 8.5 W.

Gate-loop inductance

Gate-loop inductance includes both gate inductance and driver ground inductance.

The gate inductance is the inductance between the driver output and GaN gate. With separate packages, gate inductance includes the driver output bond wire (L_{drv_out}), the GaN gate bond wire (L_{g_gan}) and the PCB trace (L_{g_pcb}), as illustrated in **Figure 1a**.

Depending on package size, gate inductance can range from a few nanohenries (nH) for a compact surface-mount package (for example, a quad flat no-lead) to more than 10 nH for a leaded power package (for example, the TO-220). If the driver is integrated with the GaN FET on the same lead frame (**Figure 1b**), the GaN gate is directly bonded to the driver output, which can reduce the gate inductance to less than 1 nH. Package integration also can significantly reduce driver ground inductance (from $L_{drv_gnd} + L_{s_pcb}$ in **Figure 1a** to L_{ks} in **Figure 1b**).

The reduction of gate-loop inductance has a great impact on switching performance, especially during turn off when the GaN gate is pulled down with a resistor. The resistor needs to be low enough so that the device does not turn back on when its drain is pulled high during switching. This resistor forms an inductor-resistor-capacitor (L-R-C) tank with the gate-source capacitance of the GaN device and the gate-loop inductance. **Equation 1** expresses the Q factor as:

$$Q = \frac{1}{R} \sqrt{\frac{L}{C}} \quad (1)$$

With a larger gate-loop inductance, the Q factor increases and ringing becomes higher. This effect is simulated with a 1- Ω pull down to turn off the low-side GaN FET, which appears around 9.97 μs in Figure 4 where the gate-loop inductance is varied from 2 nH to 10 nH. In the 10-nH case, the low-side VGS rings 12 V below the negative gate bias. This significantly increases the stress on the GaN transistor gate. Note that overstressing the gate of any FET increases reliability concerns.

Gate-loop inductance also has a significant impact on hold-off capability. When the gate of the low-side device is held at the turn-off voltage, and the high-side device is switched on, the low-side drain-gate capacitance sources a large current into the gate's hold-off loop. This current pushes the gate up through the gate-loop inductance.

Figure 4 illustrates this event at around 10.02 μs . As inductance increases, the low-side VGS is pushed higher increasing the shoot-through current, which is visible from the high-side drain current plots (ID_{HS}). The shoot-through causes the cross-conduction energy loss (E_{HS}) to increase from 53 μJ to 67 μJ .

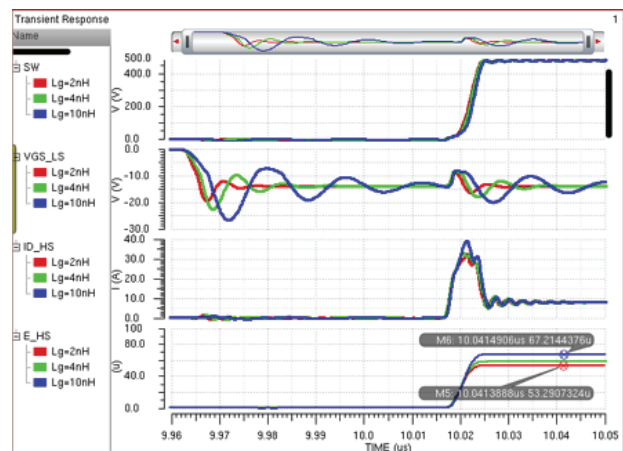

Figure 4. Low-side turn-off and high-side turn-on waveform at different gate-loop inductances: red = 2 nH, green = 4 nH, blue = 10 nH. E_{HS} is the high-side energy consumption.

One way to mitigate gate stress is to increase the pull-down resistance which in turn reduces the Q factor of the L-R-C tank, according to **Equation (1)**.

Figure 5 shows simulations with a 10-nH gate-loop inductance and pull-down resistance (Rpd) swept from 1 Ω to 3 Ω . Although the gate undershoot is limited to within a few volts below the negative bias with a 3- Ω pull down, hold-off capability becomes worse, causing larger shoot-through current. This is evident in the drain current plots.

The E_HS energy plots show an additional 13- μ J loss in each switching cycle, an almost 60 percent increase from 53 μ J compared to a 2-nH gate-loop inductance and 1- Ω pull down (**Figure 4**).

Assuming a 100-kHz switching frequency, the power loss on the high-side device increases from 5.3 W to 8 W due to shoot-through caused by both high gate-loop inductance and high pull-down resistance. This additional power loss can make it very difficult to manage heat dissipation in the power devices and increases packaging and cooling costs.

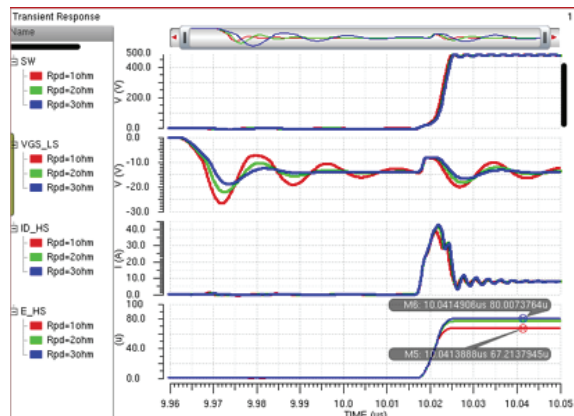

Figure 5. Simulation with 10-nH gate-loop inductance and pull-down resistance: Rpd = 1 Ω (red), 2 Ω (green) and 3 Ω (blue). E_HS is the high-side energy consumption.

It is possible to bias the gate to a more negative voltage to mitigate shoot-through, but that increases both the stress on gate, as well as dead-time loss when the device is in the third quadrant. Therefore, with high gate-loop inductance, the tradeoff between gate stress and device hold-off capability becomes difficult to manage. You would either have to increase gate stress or let the half-bridge shoot through, which increases cross-conduction loss and power-loop ringing and can cause safe operating area (SOA) issues. An integrated GaN/driver package provides low gate-loop inductance and minimizes both gate stress and shoot-through risks.

GaN device protections

Having the driver mounted on the same lead frame as the GaN transistor ensures their temperatures are close, since the lead frame is an excellent heat conductor. Thermal sensing and overtemperature protection can be built within the driver that shuts the GaN FET down when the sensed temperature goes beyond the protection limit.

A series MOSFET or a parallel GaN sense FET can be used to implement overcurrent protection. Both require low-inductance connections between the GaN device and its driver. Since GaN is usually switched very fast with large di/dt, extra inductance in the interconnection can cause ringing and requires a long blanking time to keep the current protection from misfiring. Integrating the driver ensures minimal inductive connections between the sensing circuit and the GaN FET so that the current-protection circuit can react as fast as possible to protect the device from overcurrent stress.

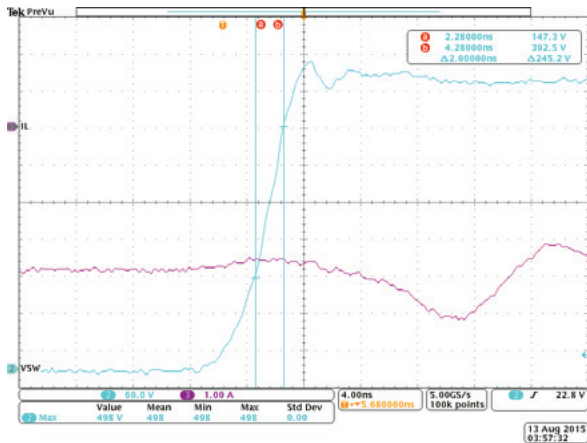

Figure 6. SW-node waveform of high-side turn on in a half-bridge buck (channel 2).

Bench-switching waveform

Figure 6 is the switching wave of a half-bridge created with two GaN devices in 8-mm-by-8-mm quad flat no-lead (QFN) packages with an integrated driver. Channel 2 shows the SW-node when the high-side device is hard-switched at a slew rate of 120 V/ns at a bus voltage of 480 V. The optimized driver-integrated package and PCB limits the overshoot to under 50V. Note the waveform was captured with a 1-GHz scope and probes.

Conclusion

The package integration of a GaN transistor with its driver eliminates common-source inductance, thus enabling high current-slew-rates. It also reduces gate-loop inductance to minimize gate stress during turn off and improves the device's hold-off capability. Integration further allows designers to build effective thermal- and current-protection circuits for GaN FETs.

More information

- Find more information about GaN at www.ti.com/gan.
- Michael Seeman and Dave Freeman. [Advancing power supply solutions through the promise of GaN](#), Texas Instruments White Paper, February 2015.
- Sandeep R. Bahl. [A comprehensive methodology to qualify the reliability of GaN products](#), Texas Instruments White Paper, March 2015.
- Download the free software tool: [TINA-TI](#).
- Narendra Mehta. [GaN FET module performance advantage over silicon](#), Texas Instruments White Paper, March 2015.
- Zhong Ye, [GaN FET-Based CCM Totem-Pole Bridgeless PFC](#), Texas Instruments Power Supply Design Seminar, 2014.

Important Notice: The products and services of Texas Instruments Incorporated and its subsidiaries described herein are sold subject to TI's standard terms and conditions of sale. Customers are advised to obtain the most current and complete information about TI products and services before placing orders. TI assumes no liability for applications assistance, customer's applications or product designs, software performance, or infringement of patents. The publication of information regarding any other company's products or services does not constitute TI's approval, warranty or endorsement thereof.

The platform bar is a trademarks of Texas Instruments.
All other trademarks are the property of their respective owners.

B021014

IMPORTANT NOTICE

Texas Instruments Incorporated and its subsidiaries (TI) reserve the right to make corrections, enhancements, improvements and other changes to its semiconductor products and services per JESD46, latest issue, and to discontinue any product or service per JESD48, latest issue. Buyers should obtain the latest relevant information before placing orders and should verify that such information is current and complete. All semiconductor products (also referred to herein as "components") are sold subject to TI's terms and conditions of sale supplied at the time of order acknowledgment.

TI warrants performance of its components to the specifications applicable at the time of sale, in accordance with the warranty in TI's terms and conditions of sale of semiconductor products. Testing and other quality control techniques are used to the extent TI deems necessary to support this warranty. Except where mandated by applicable law, testing of all parameters of each component is not necessarily performed.

TI assumes no liability for applications assistance or the design of Buyers' products. Buyers are responsible for their products and applications using TI components. To minimize the risks associated with Buyers' products and applications, Buyers should provide adequate design and operating safeguards.

TI does not warrant or represent that any license, either express or implied, is granted under any patent right, copyright, mask work right, or other intellectual property right relating to any combination, machine, or process in which TI components or services are used. Information published by TI regarding third-party products or services does not constitute a license to use such products or services or a warranty or endorsement thereof. Use of such information may require a license from a third party under the patents or other intellectual property of the third party, or a license from TI under the patents or other intellectual property of TI.

Reproduction of significant portions of TI information in TI data books or data sheets is permissible only if reproduction is without alteration and is accompanied by all associated warranties, conditions, limitations, and notices. TI is not responsible or liable for such altered documentation. Information of third parties may be subject to additional restrictions.

Resale of TI components or services with statements different from or beyond the parameters stated by TI for that component or service voids all express and any implied warranties for the associated TI component or service and is an unfair and deceptive business practice. TI is not responsible or liable for any such statements.

Buyer acknowledges and agrees that it is solely responsible for compliance with all legal, regulatory and safety-related requirements concerning its products, and any use of TI components in its applications, notwithstanding any applications-related information or support that may be provided by TI. Buyer represents and agrees that it has all the necessary expertise to create and implement safeguards which anticipate dangerous consequences of failures, monitor failures and their consequences, lessen the likelihood of failures that might cause harm and take appropriate remedial actions. Buyer will fully indemnify TI and its representatives against any damages arising out of the use of any TI components in safety-critical applications.

In some cases, TI components may be promoted specifically to facilitate safety-related applications. With such components, TI's goal is to help enable customers to design and create their own end-product solutions that meet applicable functional safety standards and requirements. Nonetheless, such components are subject to these terms.

No TI components are authorized for use in FDA Class III (or similar life-critical medical equipment) unless authorized officers of the parties have executed a special agreement specifically governing such use.

Only those TI components which TI has specifically designated as military grade or "enhanced plastic" are designed and intended for use in military/aerospace applications or environments. Buyer acknowledges and agrees that any military or aerospace use of TI components which have **not** been so designated is solely at the Buyer's risk, and that Buyer is solely responsible for compliance with all legal and regulatory requirements in connection with such use.

TI has specifically designated certain components as meeting ISO/TS16949 requirements, mainly for automotive use. In any case of use of non-designated products, TI will not be responsible for any failure to meet ISO/TS16949.

Products

Audio	www.ti.com/audio
Amplifiers	amplifier.ti.com
Data Converters	dataconverter.ti.com
DLP® Products	www.dlp.com
DSP	dsp.ti.com
Clocks and Timers	www.ti.com/clocks
Interface	interface.ti.com
Logic	logic.ti.com
Power Mgmt	power.ti.com
Microcontrollers	microcontroller.ti.com
RFID	www.ti-rfid.com
OMAP Applications Processors	www.ti.com/omap
Wireless Connectivity	www.ti.com/wirelessconnectivity

Applications

Automotive and Transportation	www.ti.com/automotive
Communications and Telecom	www.ti.com/communications
Computers and Peripherals	www.ti.com/computers
Consumer Electronics	www.ti.com/consumer-apps
Energy and Lighting	www.ti.com/energy
Industrial	www.ti.com/industrial
Medical	www.ti.com/medical
Security	www.ti.com/security
Space, Avionics and Defense	www.ti.com/space-avionics-defense
Video and Imaging	www.ti.com/video

TI E2E Community

e2e.ti.com