

## Tube Cricket Build Guide



The Tube Cricket is a small-wattage amp that puts out about 1 watt of audio power. With a 12AU7 tube-preamp and a JRC386 power amp, the Tube Cricket gives you great tone in a compact package, and is great for practicing or low wattage shredding. This Build Guide shows you how to build your own Tube Cricket.

**Officially Licensed Circuits**  
Copyright © 2008  
[www.olcircuits.com](http://www.olcircuits.com)  
doc by dano/beavisaudio.com

# Table of Contents

Power Supply Board Parts .....	5
Step 1: Populating the Main Board.....	6
Step 2: Populating the Power Supply Board .....	10
Step 3: Enclosure Assembly .....	11
Step 4: Wiring the Enclosure Hardware .....	12
Step 5: Tube Time.....	19
Troubleshooting .....	20

## Parts List

The following list shows each part of the kit. Go over the list and ensure that you received all the parts. The values in the Code column show the color codes for the resistors and the number codes for the capacitors.

Schematic #	Part Value	Code/Notes
<b>Resistors</b>		
R1	4.7K $\Omega$	
R2	220 $\Omega$	
R3	220 $\Omega$	
R4	1M $\Omega$	
R5	68K **	
R6	1M $\Omega$	
R7	4.7K $\Omega$	
R8	100K $\Omega$	
R9	1M $\Omega$	
R10	56K $\Omega$	
R11	4.7K $\Omega$	
R12	10 $\Omega$	
R13	100 $\Omega$	
VR1	100K $\Omega$ Trimmer	
VR2	500K $\Omega$ Linear Taper (Tone)	
VR3	100K $\Omega$ Trimmer	
VR4	100K $\Omega$ Audio Taper (Volume)	
VR5	1K $\Omega$ Linear Taper (Gain)	

<b>Capacitors</b>		
C1	220 $\mu$ F polarized electrolytic	
C2	220 $\mu$ F polarized electrolytic	
C3	220 uf polarized electrolytic	
C4	4.7 nF	472
C5	10 uf polarized electrolytic	
C6	47 nF	473
C7	4.7 nF	472
C8	10 nF	103
C9	47 nF	473
C10	10 uf polarized electrolytic	
C11	100 nF	104
C12	10 uf polarized electrolytic	
C13	47 nF	473
C14	220 uf polarized electrolytic	
<b>Semiconductors</b>		
D1		1N4001
D2		LED
U1		JRC386
<b>Tube</b>		
V1		12AU7 Dual Triode
<b>Hardware</b>		
Aluminum enclosure		Hammond 1590BB style
DC jack		Black plastic with chrome nut
LED		Color varies with kit/order
LED bezel clip		Black plastic ring with notches
LED bezel ring		Black plastic ring
Heat shrink tubing (2)		Insulators for LED leads
Knobs (3)		Quarter inch plastic
¼" input jack		
¼" input jack		
Tube socket		
Roll bars (2)		
12 VAC adaptor		

# Power Supply Board Parts

---

This list contains the parts for the separate power supply board.

C1, C2	100 $\mu$ F polarized electrolytic	
B1	W01 Bridge Rectifier	
IC2	LM7812 voltage regulator	

# Step 1: Populating the Main Board

The PCB is a single sided board that holds all the components with the exception of the potentiometers, LED, jacks, tube, and DC adaptor.

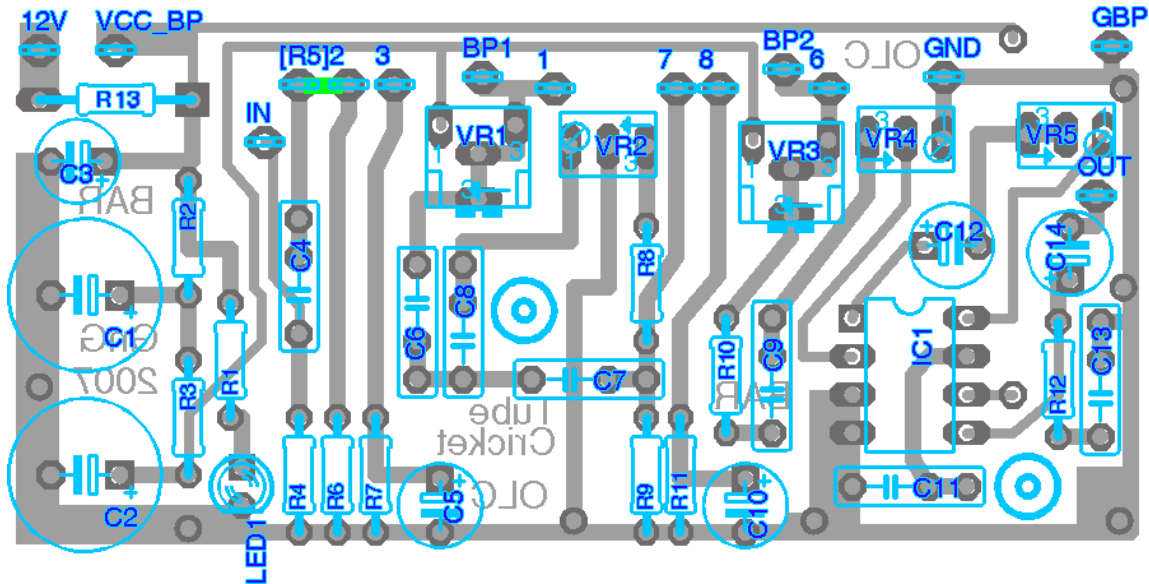

Layout Diagram

Before soldering any parts, use some fine steel wool to gently rub over the copper traces. This will remove any oxidation and ensure that your solder bonds to the copper pads.

Insert components on the blank side (the side without any copper traces) through the appropriate holes. Take your time as you figure out the correct holes for the components. You may find it useful to identify “landmarks” in the hole patterns—for example look for the closest transistor which will be three holes close together in a vertical strip. Having a landmark makes it easier to get your bearings. Don’t be afraid to turn the board over and look at the copper traces and pads, but remember you’re looking at the reverse image...

For each component, bend the wires on the other side flat to help hold the component in place while you solder. Nip off the ends of the wires after the solder has hardened so that there is no wire left sticking out of the solder blob.



**Note:** The pictures shown in this build guide may depict components that differ slightly in color and packing or size from the components that are included in your kit. This is due to variations if components and vendors. Be sure to double check the codes of components (color bands for resistors, codes for capacitors, etc.) against those listed in the Parts List section earlier in this document to ensure you working with the correct value.

# Jumpers

The board has two jumpers.

- For the jumper shown in red, cut a piece of insulated hook-up wire to length and solder it in place.
- For the jumper shown in green, use a left over piece of resistor or capacitor lead and solder into place. The reason we want a bare wire jumper here is is that we'll solder a wire to it later in the process.

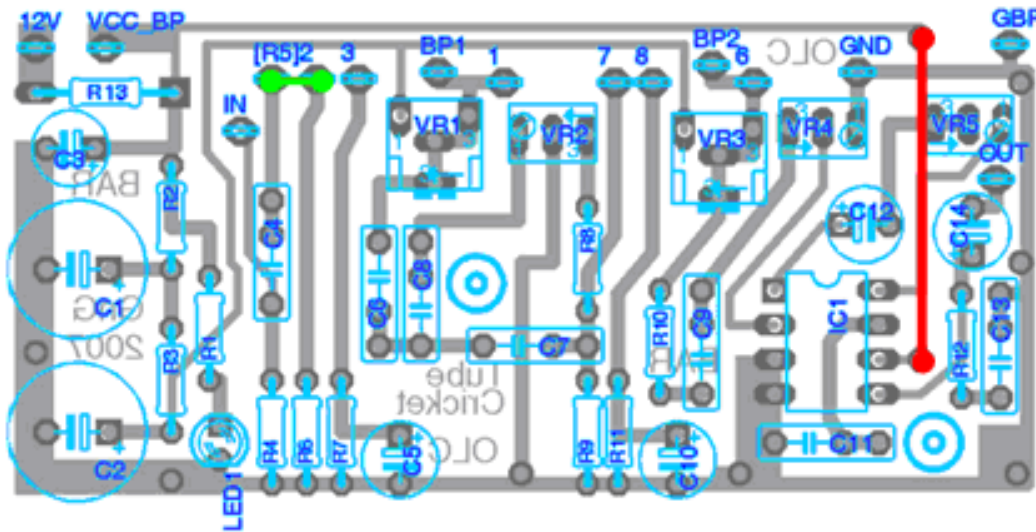

# Resistors

Start with the resistors (don't worry about the potentiometers or trimmer pots in this step, just do the fixed resistors). Carefully check each resistor against the color band code in the parts list. You may also find it helpful to you have your digital multimeter on and set to Ohms for this step. After you check and verify the color codes of a resistor, and before you solder them to the board, double-check the value with your meter. Note that resistors do not have polarity (i.e. there is no positive or negative side) so you can insert them in either direction.

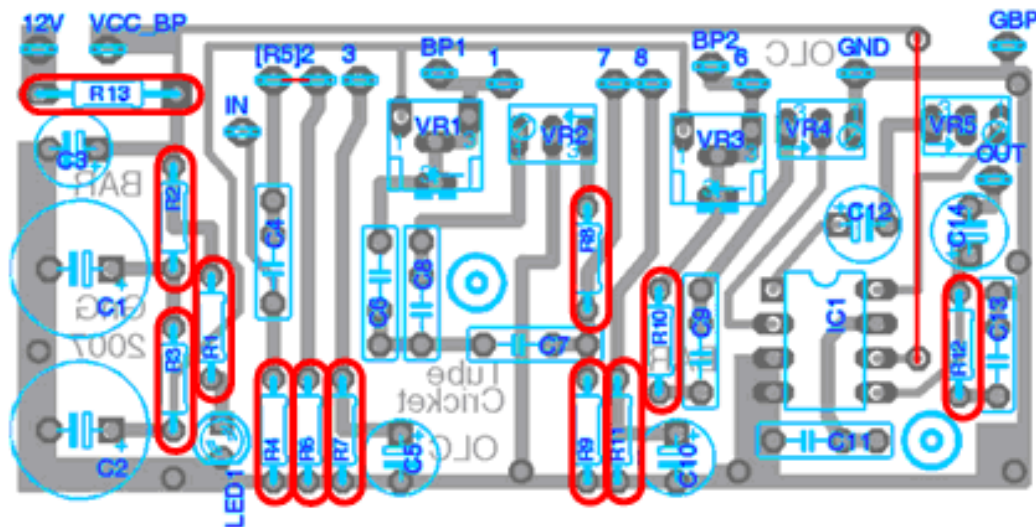

## Trimmers

Now install the two trimmer pots. These have three legs that form a “T” formation. You’ll see how that line up on the board. Because the legs are a bit bigger than standard component leads, you may have to gently rock them into place. Be careful—too much pressure or not aligning the legs with holes will bend the legs—not a really big problem, but if you bend them too many times, they will break.

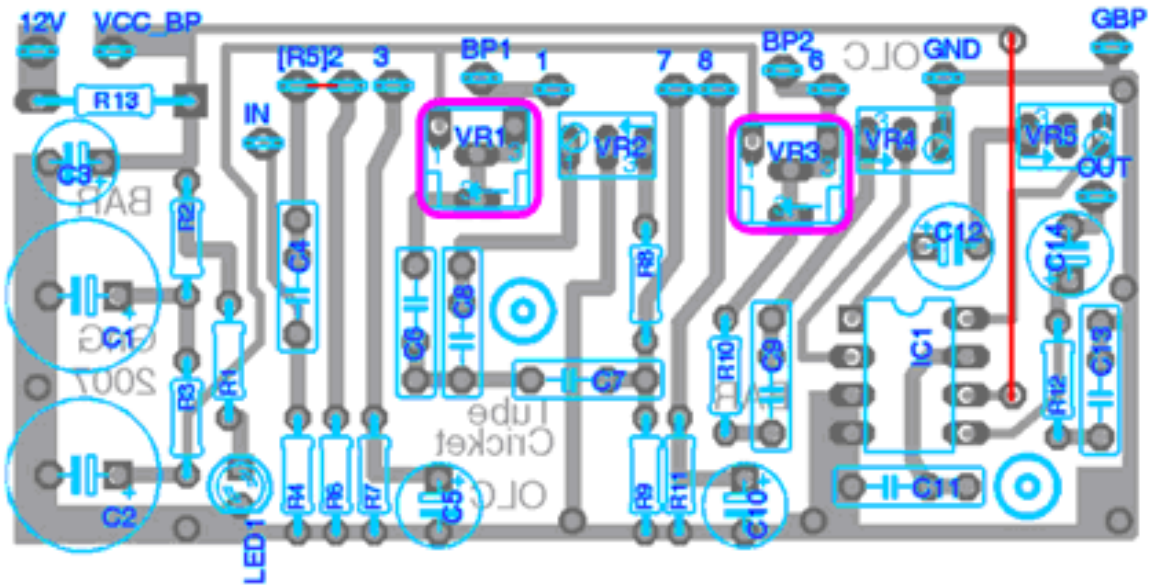

## IC Socket

In this step you will install the IC socket for the JRC386 power amp.

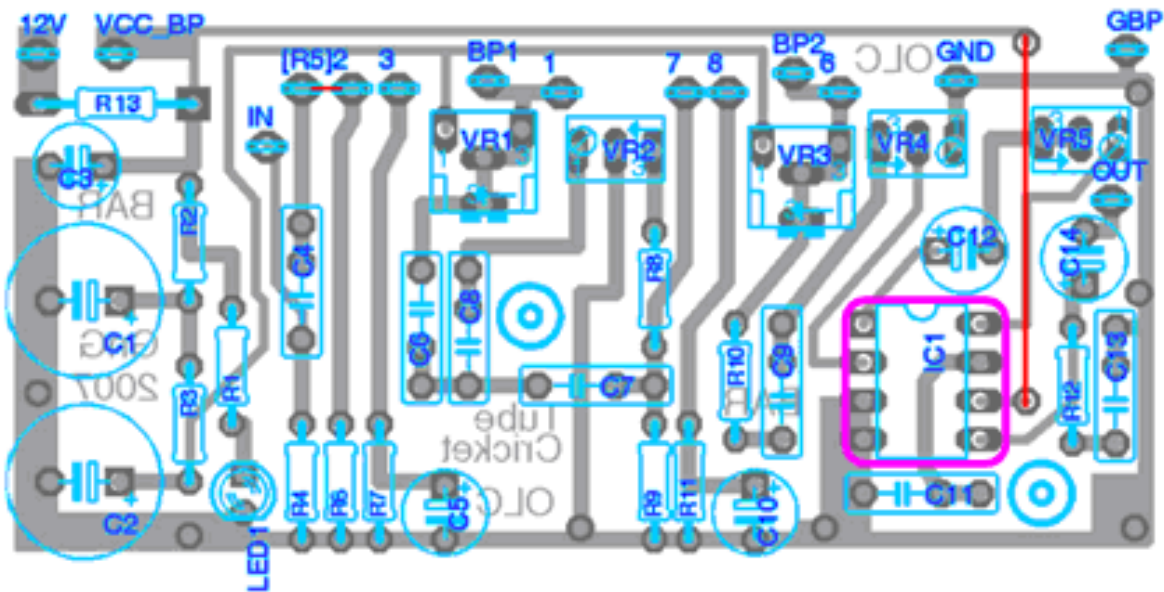



# Capacitors

The circuit uses non-polarized film capacitors in addition to polarized electrolytic capacitors. Polarized capacitors have a positive and a negative side—look at the capacitor to see which lead is which. Install the polarized caps in the correct orientation according to the layout diagram. You will see a + sign for the hole where the positive lead should go. All other capacitors are non-polarized—it doesn't matter which side is which. As with the resistors, check each capacitor's code value against those listed in the Parts List to ensure you have the right value. If your multimeter has the ability to measure capacitors it would be a good idea to double check them before solder them in. The following diagram shows the non-polarized capacitors in red and the polarized ones in purple.

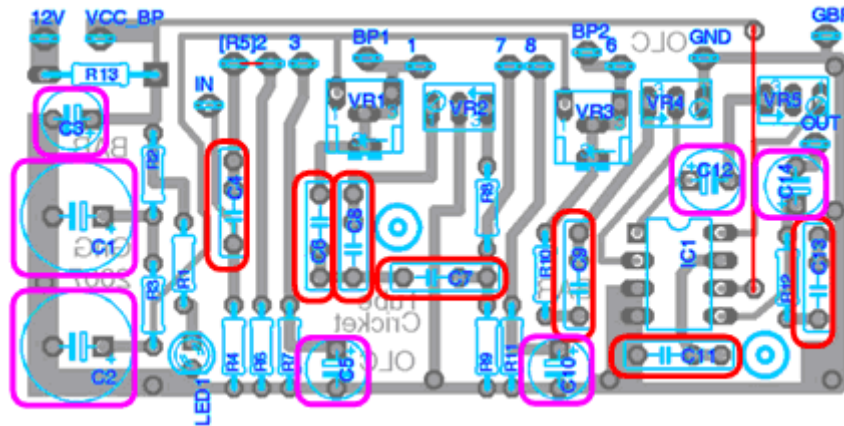

## Time to Double Check

Now that the PCB components are mounted, it is a good time to double-check your work. You'll find that most difficult-to-solve problems involve the PCB. You'll want to check for:

- Components are mounted in the wrong holes
- Polarity is reversed (polarized capacitors, ICs, transistors, diodes)
- Cold solder joints (i.e. the solder was not sufficiently heated/spread to make contact between the component lead and the copper pad)
- Unsoldered components: its easy to overlook one or two leads.
- Solder bridges: places where solder has flowed between two or more connectors that shouldn't be connected.

The main PCB is done for now. Set it aside for now and we'll start working on the enclosure.

## Step 2: Populating the Power Supply Board

---

If your kit came with an AC-AC power supply and a small power supply board, you populate the small board now. If your kit came with a DC supply, you can omit this step.

The second smaller PCB is for the power supply. It converts the input 12 V AC to DC and smoothes out the supply.

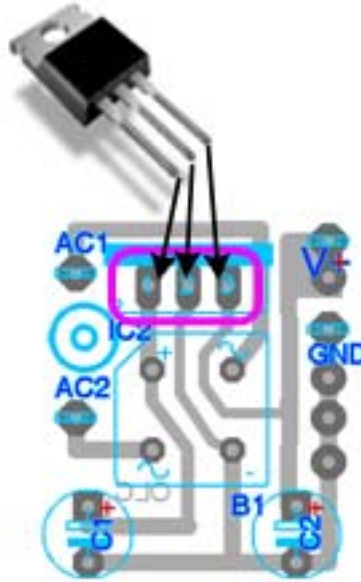

## Step 3: Enclosure Assembly

Now that you have most of the PCB done, its time to start work on the enclosure. If you ordered an un-drilled enclosure, drill the appropriate holes for the parts. If you received a drilled enclosure, you're ready to go.

Install the parts as shown below.



**Note:** The pictures and graphics below regarding the enclosure are shown from the perspective of looking into the back of the pedal (i.e. the screw-holes for the enclosure bottom are facing up).

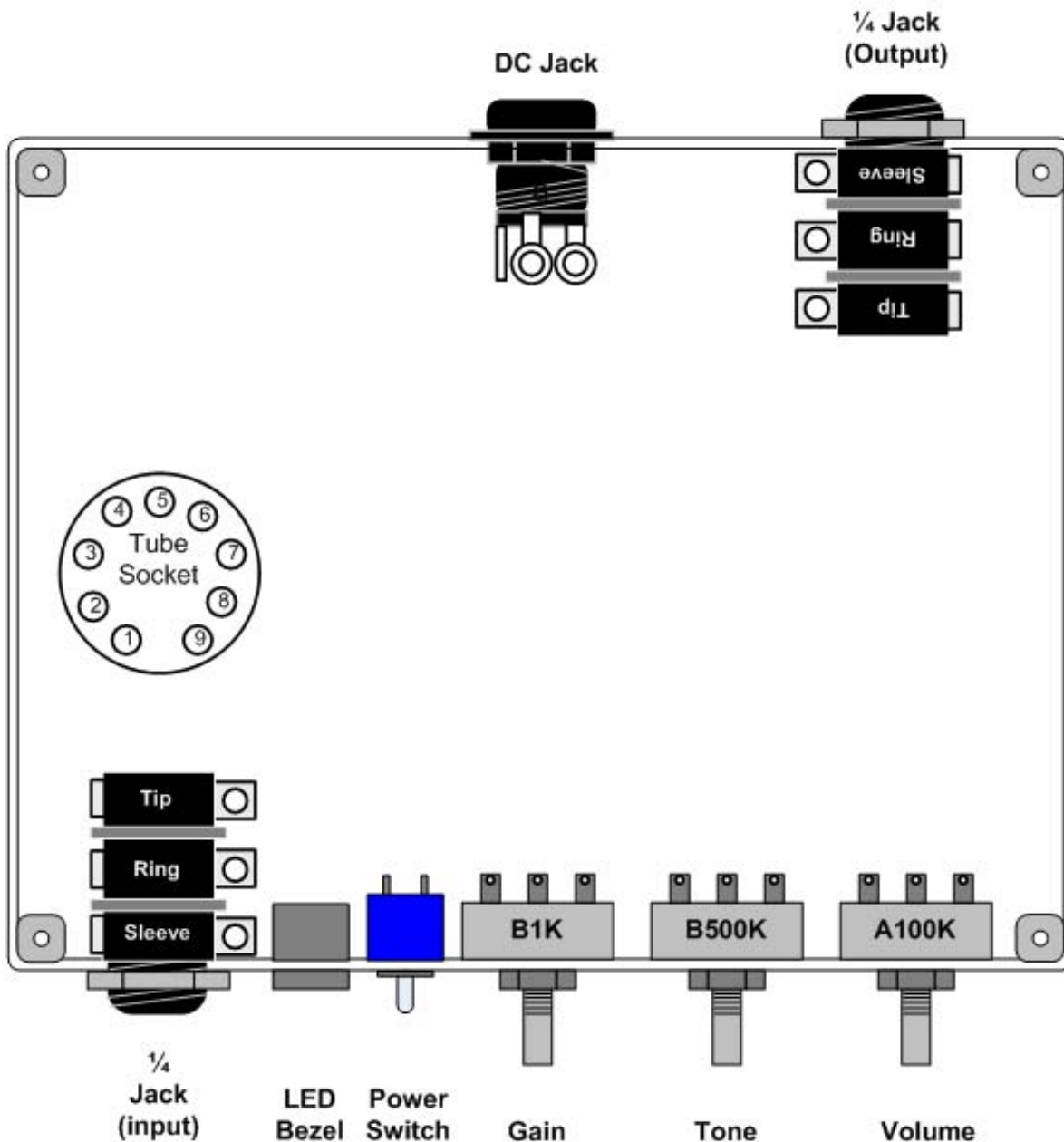

## Step 4: Wiring the Enclosure Hardware

Now that all the parts are physically installed in the box, you can start the wiring process. In this step, you'll wire up the input and output jacks, the switch, LED, battery clip and AC adaptor connector.

You have two goals in this step: to correctly wire all the parts together exactly as shown, and to keep your wires to the minimum length necessary to fit in the box. Why short lengths? First off, shorter wires reduce noise—the longer the wire, the greater the chance that it can act as an antenna for picking up stray radio frequency or other interference. This is especially true in effects that are high gain by nature. The second reason to keep your wire lengths short is that it makes it easier to end up with a professional looking build that doesn't have a bunch of wires compressed between pots and the boards, wires that get folded over and looped by battery clip, etc. Each wire also represents an opportunity for mechanical failure. Each time physical stress is put on a wire, the wire itself and the solder joints it connects to can weaken. During the build process you will be putting parts in, maneuvering them around the enclosure, fixing problems, and other things.

### Wiring the Hardware

Wire the hardware in the enclosure according to the following diagram. Note that the lines in the diagram do not represent the actual lengths of wire to use—as mentioned above, try to keep your lead lengths to a minimum.

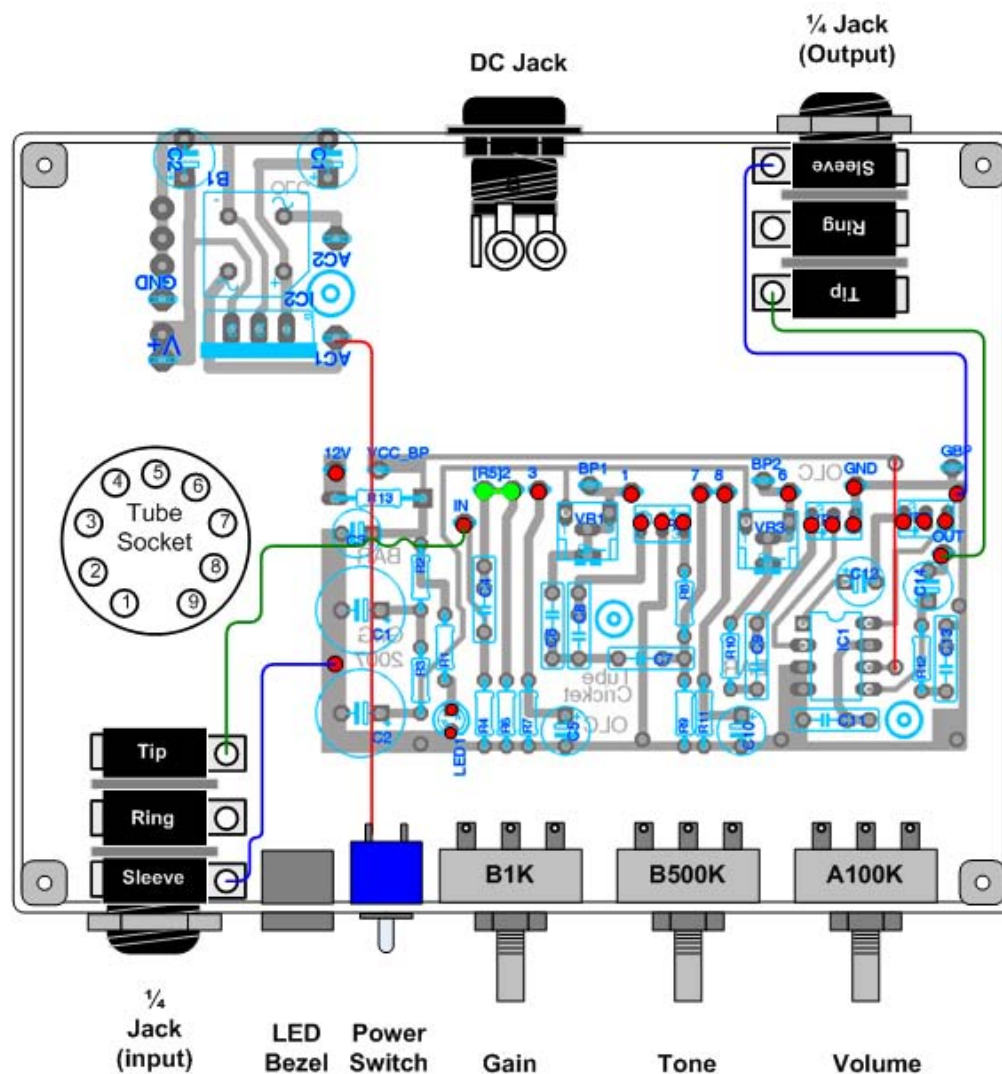

## Wiring the Power Supply

In this step, you'll wire in the power switch, the small power supply PCB, and wire it to the tube and "12V" on the PCB, as shown here:

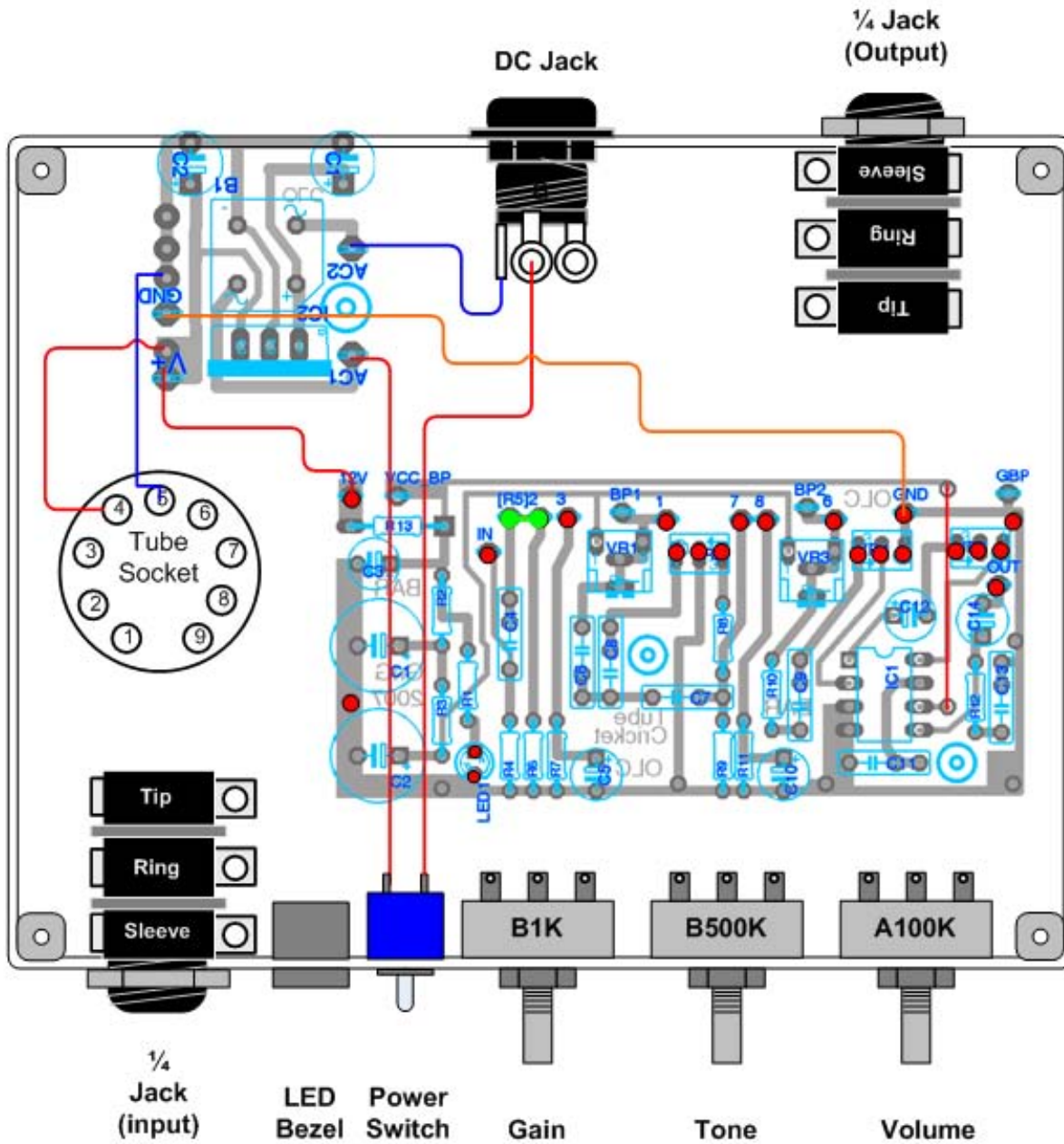

## Wiring the Potentiometers

In this step, you'll wire all of the connections from the PCB to the potentiometers. Make sure you pay special attention to the pin numbers on the pots. Here are some tips for wiring pots:

To make it easier, try these tips:

1. Use a permanent marker to label the back of each pot. For example, "B" for bass, "V" for volume and so on. Be sure to check the potentiometer value before labeling them. Adding these letters can help save a world of hurt later when you realize you wired the wrong pot to the wrong part of the PCB!
2. Before wiring the pots, remove them from the enclosure.
3. Wire one pot at a time. Measure the amount of wire you'll need to reach the board from that particular pot and leave a little excess. For your measurements, take into account whether the pot wires will need to go under the PCB or on top. (Under makes for a cleaner looking build.) Solder the three wires to the pot.
4. Before you solder the wires to the PCB, use some extra heat-shrink tubing to organize the 3-wires into bundles.
5. Take your time and work carefully when inserting the pot wires into the PCB. The PCB holes are quite small, and you want to be sure that you don't leave any stray strands of wire sticking out on the top (non-copper) part of the board.

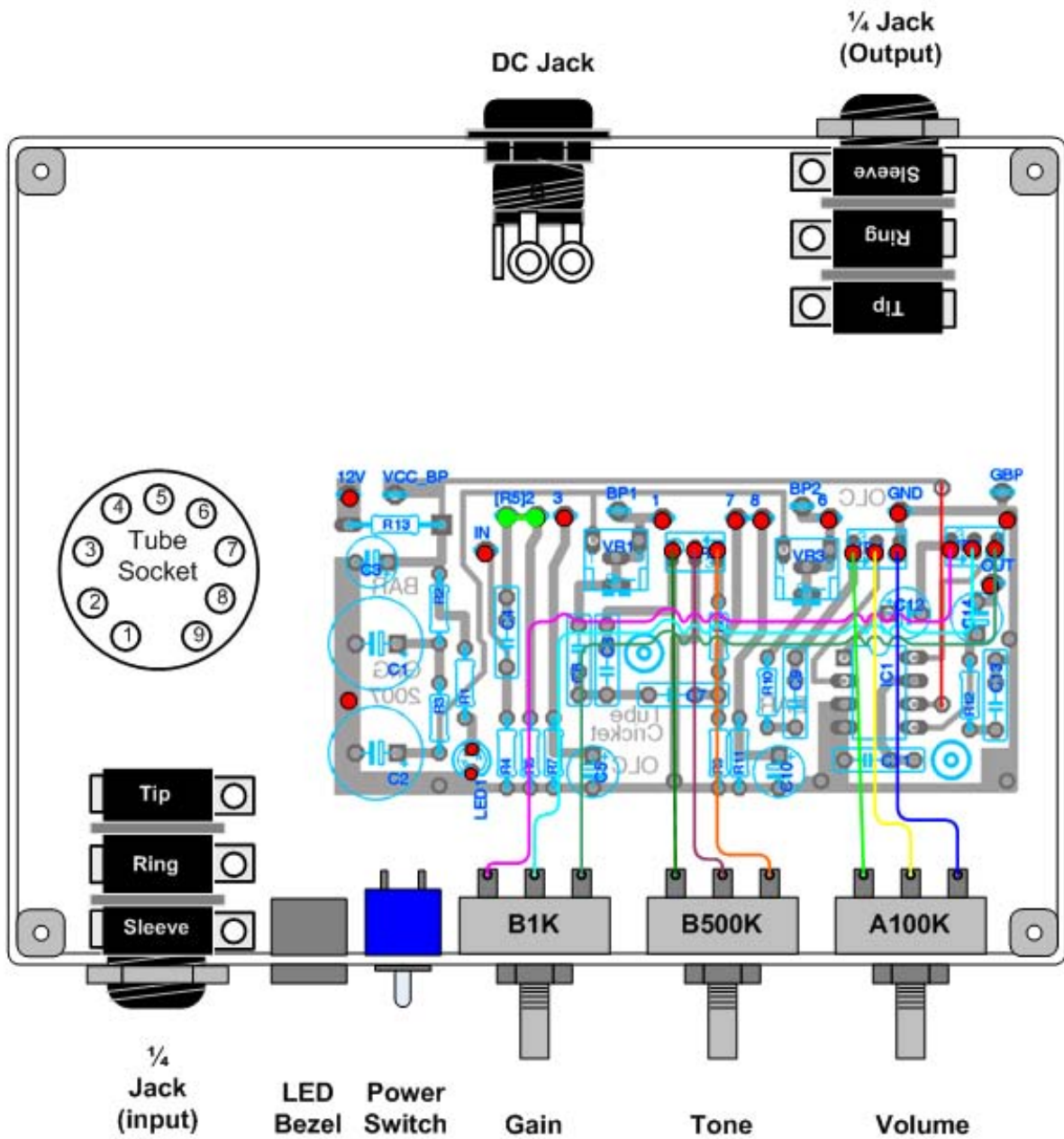

# Tube Wiring

In this step you run the wires from the PCB to the tube socket. The numbers on the tube socket correspond to the tube pin numbers on the PCB.

- Pins 1, 3, 6, 7, and 8 are wired directly to the PCB.
- Pin 2 is soldered directly to the R5 resistor. The other end of the R5 resistor is soldered to the wire jumper you added when you populated the PCB, shown below in bright green.
- Pin 4 was soldered to the power supply in a previous step.

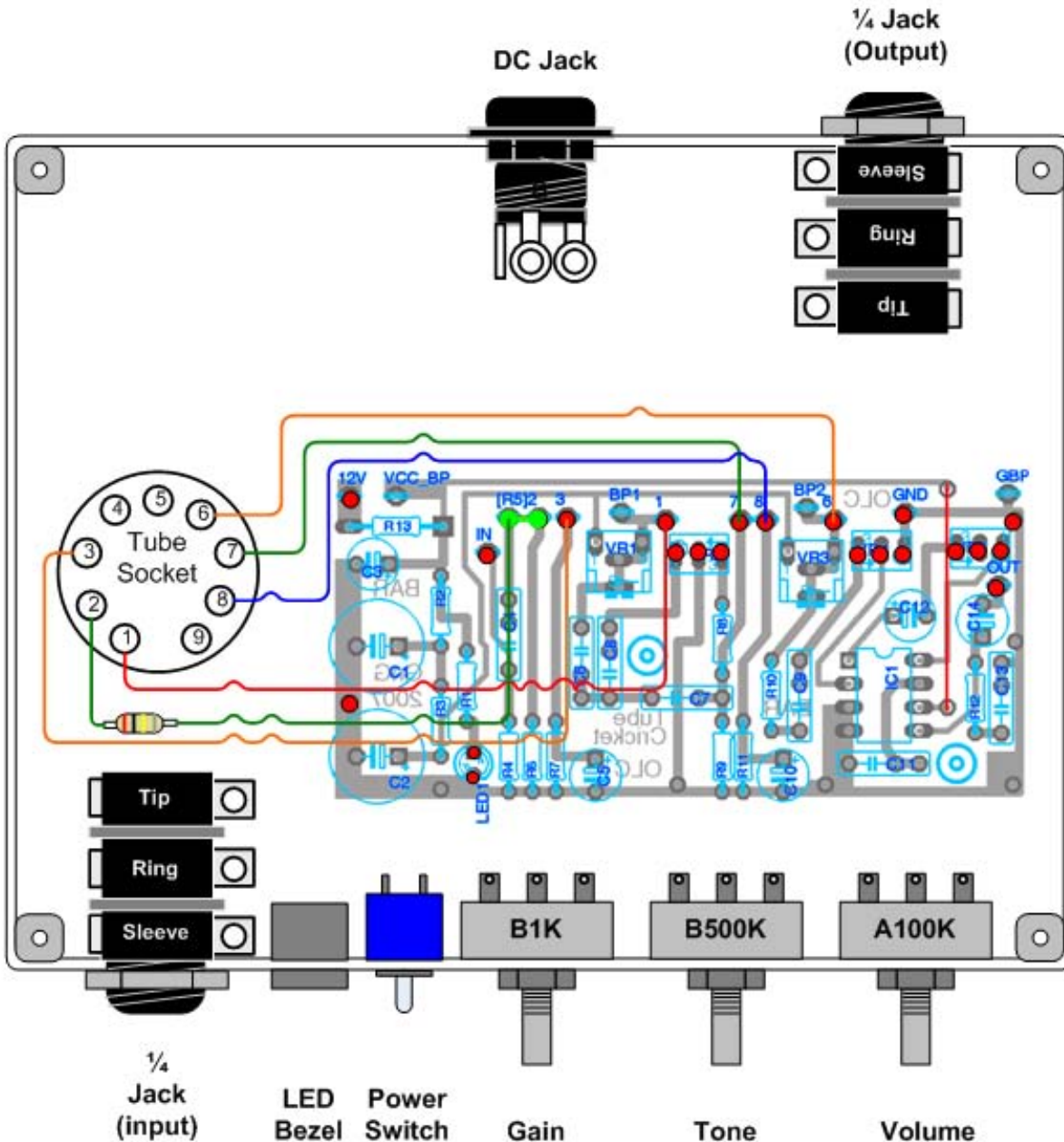



## Wire the LED

The final wiring is two wires for the LED as shown below. Insert the LED into the bezel. The long lead on the LED is + and the short lead is negative. Wire them as shown.

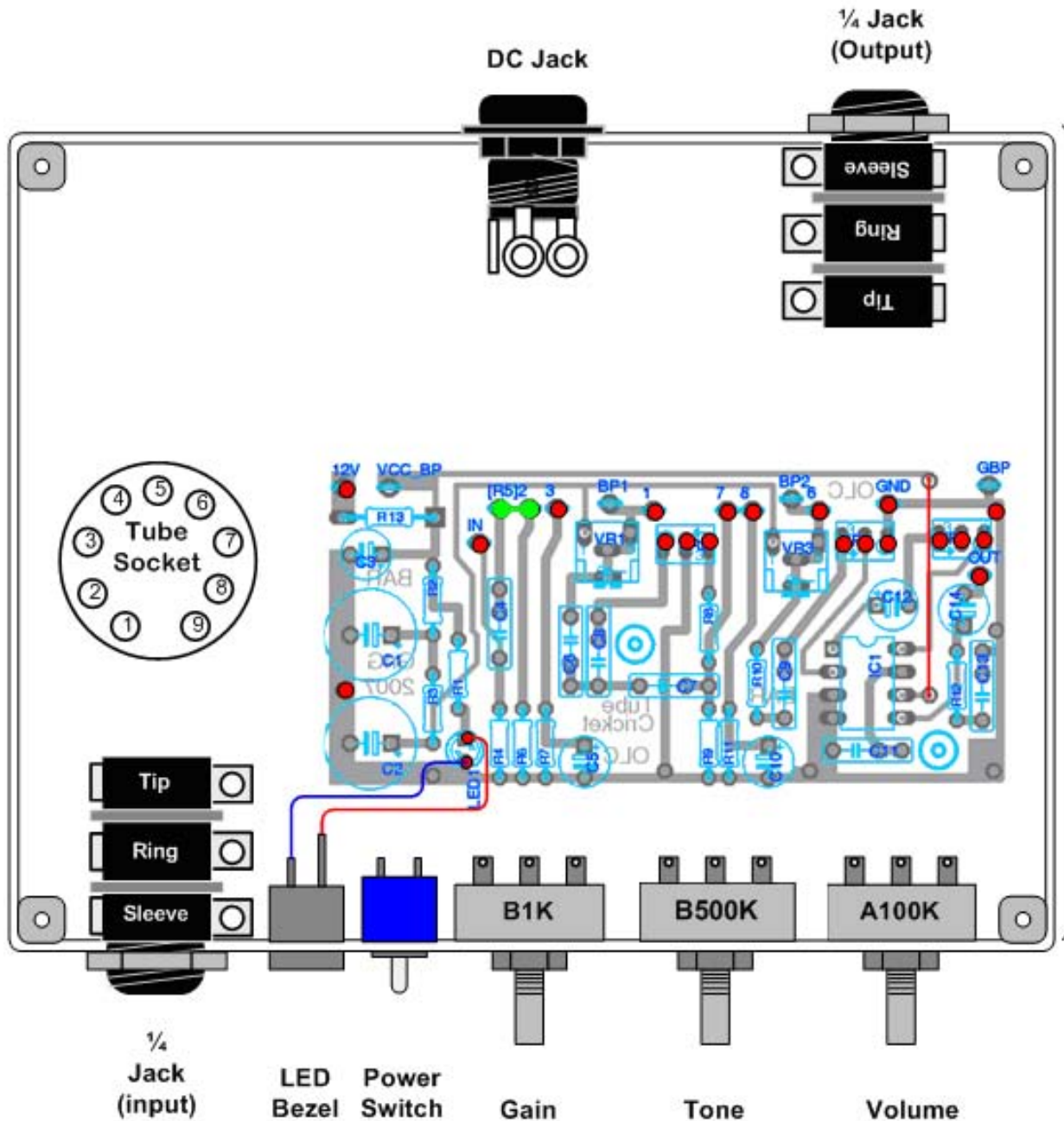

## Before you close the case

Before you close everything up, double-check your wiring once more. Also check that no exposed wires or other parts of the circuit are touching the cover as you put it on. Look for any wires that are loose, and be sure to tuck all wires neatly into the case so they don't get caught between the case and the lid.

Install the JRC386 chip into the socket—be sure the notch or dot on the chip aligns with the notch as shown on the PCB layout picture.

In the next steps, you'll set the bias trimmers for the tube, so leave the bottom of the case off for now.

# Step 5: Tube Time

---

The tube in your kit is a 12AU7 twin triode. This means that the tube has two distinct gain sections in one tube. There is a trimmer on the PCB for each of these two gain stages. This section will explain how to bias the tube.

## Setting the Tube Bias Levels

1. Plug the 12 volt adaptor into a wall socket and plug the adaptor plug into the back of the enclosure.
2. Connect the negative lead (black) of your multimeter to the ground lug on the board.
3. Touch the positive lead (red) of your multimeter to BP1 bias point on the PCB.
4. Adjust the VR1 trimpot until your multimeter reads approximately 9v+ which is  $\frac{3}{4}$  of the supply voltage.
5. Repeat these steps for the second triode which is BP2 bias point and the VR3 trimmer.

# Troubleshooting

---

If you've done everything correctly, your pedal should work just fine. However, it is pretty rare that a DIY pedal works on the first try. There are many variables, and each one has to be addressed correctly. If your pedal doesn't work on the first try, relax. This is typically how it goes. A little bit of troubleshooting and patience will get you there. This section lists things to check that address common mistakes.

## The Obvious Stuff

These are the things that are so obvious that we rarely look at them first. But they may save a lot of trouble!

- Is your guitar plugged into the input jack securely?
- Is your guitar turned up?
- Is your amp plugged directly into the output of the pedal? You should go straight into your amp for testing to eliminate the possibility that other pedals or effects/wire/power are not causing the issue.
- Do you have power? Is a battery connected? Is the battery fresh? If you are using an AC adaptor, is it plugged in?

## Power

- Is the pedal PCB getting power? Use your multimeter to ensure that you are getting around 9v by placing your red (+) probe on the pad that provides power (9vDC+) and any ground pad on the PCB. If you aren't getting voltage, re-check your power wiring and connections.
- Are you using an AC Adaptor? Make sure it is a 9vDC supply and that the jack is tip-negative. Make sure it is actually plugged in and functioning by using your multimeter.

## Components

- Look at the PCB and the PCB Layout. Compare each value for the resistors and the capacitors. Check off each one as you verify it.
- Make sure the transistors are oriented correctly. This is a very common problem.
- If your circuit uses polarized capacitors, make sure they are oriented correctly.
- Could an IC or transistor have wiggled out of its socket? Check all socketed components.

## Wiring

- Go back and double-check your wiring. Work through the diagrams shown in each step. Print out this build guide and use your pen or pencil to place a check mark next to each wire as you verify that both ends go to the correct places.
- Visually inspect each wire to make sure that stray strands are not leading off in unwanted directions which can cause short circuits.

## Soldering

- You've done a lot of soldering in this project. There is a good chance that a bad solder joint is causing problems. Use a magnifying glass to visually inspect the back (solder-side) of the PCB. Compare it against the PCB layout in this document. Are there any solder "bridges" that connect traces or lugs that shouldn't be there?
- Are there connections on the PCB that look loose or non-shiny? They may need to be re-soldered.
- Also check the soldering on all the hardware parts attached to the enclosure hardware (switches, jacks, pots, etc.) Make sure that none are loose. Use your multimeter continuity feature to check each connection.

## Come Back Later

The longer you work on trouble-shooting in a single session, the less productive you become. Frustration can cloud your mind and dramatically reduce your innate problem solving skills.

Put your work away for a few hours or a day. Do something different. Play your guitar. Take a walk. Play with your kids. You'll be amazed at how productive and refreshed mind can be. Remember, building pedals is about fun and learning. So you should be having fun! ☺

## Getting Help

If you've tried the troubleshooting steps and are still having problems, please visit Officially Licensed Circuits on the web at [www.olcircuits.com](http://www.olcircuits.com).