

A
B
MT
D
E
F
G
H
I
J
K
L
M

SECTION **MT**

MANUAL TRANSMISSION

CONTENTS

PRECAUTIONS	2	SHIFT CONTROL	13
Caution	2	Removal and Installation of Control Lever Assembly..	13
Precautions for Battery Service	2	REMOVAL	13
PREPARATION	3	INSTALLATION	15
Special Service Tools	3	INSPECTION AFTER INSTALLATION	17
Commercial Service Tools	6	AIR BREATHER HOSE	18
NOISE, VIBRATION AND HARSHNESS (NVH)		Removal and Installation	18
TROUBLESHOOTING	7	TRANSMISSION ASSEMBLY	19
NVH Troubleshooting Chart	7	Removal and Installation from Vehicle	19
MANUAL TRANSMISSION	7	REMOVAL	19
DESCRIPTION	8	INSTALLATION	21
Cross-Sectional View	8	Component Parts Drawing	22
DOUBLE-CONE SYNCHRONIZER (MODEL		CASE COMPONENTS	22
CODE NUMBER. CD000)	9	GEAR COMPONENTS (MODEL CODE NUM-	
DOUBLE-CONE SYNCHRONIZER (MODEL		BER. CD000)	23
CODE NUMBER. CD005)	9	GEAR COMPONENTS (MODEL CODE NUM-	
TRIPLE-CONE SYNCHRONIZER (MODEL		BER. CD005)	25
CODE NUMBER. CD005)	9	SHIFT CONTROL COMPONENTS	27
M/T OIL	10	Disassembly and Assembly	29
Replacement	10	DISASSEMBLY	29
DRAINING	10	INSPECTION AFTER DISASSEMBLY	39
FILLING	10	ASSEMBLY	44
Checking	10	SERVICE DATA AND SPECIFICATIONS (SDS)	61
OIL LEAKAGE AND OIL LEVEL	10	General Specifications	61
REAR OIL SEAL	11	End Play	62
Removal and Installation	11	Snap Rings	62
REMOVAL	11	Baulk Ring Clearance (Model code number.	
INSTALLATION	11	CD000)	63
POSITION SWITCH	12	Baulk Ring Clearance (Model code number.	
Checking	12	CD005)	63
COMPONENT LOCATION	12		
BACK-UP LAMP SWITCH	12		
NEUTRAL POSITION SWITCH	12		

PRECAUTIONS

PRECAUTIONS

PFP:00001

Caution

ACS003TP

- Do not reuse transmission oil, once it has been drained.
- Check oil level or replace oil with vehicle on level ground.
- During removal or installation, keep inside of transmission clear of dust or dirt.
- Check for the correct installation status prior to removal or disassembly. If mating marks are required, be certain they do not interfere with the function of the parts they are applied to.
- In principle, tighten bolts or nuts gradually in several steps working diagonally from inside to outside. If tightening sequence is specified, observe it.
- Be careful not to damage sliding surfaces and mating surfaces.

Precautions for Battery Service

ACS003TQ

Before disconnecting the battery, lower both the driver and passenger windows. This will prevent any interference between the window edge and the vehicle when the door is opened/closed. During normal operation, the window slightly raises and lowers automatically to prevent any window to vehicle interference. The automatic window function will not work with the battery disconnected.

PREPARATION



PREPARATION

PFP:00002

Special Service Tools

ACS003T8

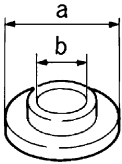
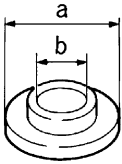
The actual shapes of Kent-Moore tools may differ from those of special service tools illustrated here.

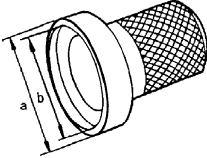
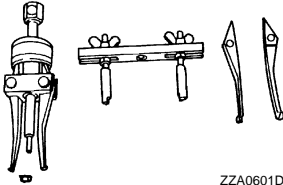
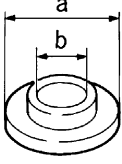
Tool number (Kent-Moore No.) Tool name	Description
ST30911000 (—) a: 98 mm (3.86 in) dia. b: 40 mm (1.57 in) dia. Inserter	 <p style="text-align: center;">ZZA0920D</p> Mainshaft ball bearing installation 5th - 6th synchronizer assembly installation Reverse main gear installation
ST30022000 (—) a: 110 mm (4.33 in) dia. b: 46 mm (1.81 in) dia. Inserter	 <p style="text-align: center;">ZZA0920D</p> 3rd main gear installation 4th main gear installation
ST27861000 (—) a: 62 mm (2.44 in) dia. b: 52 mm (2.05 in) dia. Support ring	 <p style="text-align: center;">ZZA0832D</p> 1st - 2nd synchronizer assembly installation 1st gear bushing installation
ST33400001 (J26082) a: 60 mm (2.36 in) dia. b: 47 mm (1.85 in) dia. Drift	 <p style="text-align: center;">ZZA0814D</p> Rear oil seal installation
KV381054S0 (—) Oil seal puller	 <p style="text-align: center;">ZZA0601D</p> Remove rear oil seal
ST30032000 (J26010-01) a: 80 mm (3.15 in) dia. b: 31 mm (1.22 in) dia. Inserter	 <p style="text-align: center;">ZZA0920D</p> Counter rear bearing inner race installation

A
 B
 MT
 D
 E
 F
 G
 H
 I
 J
 K
 L
 M

PREPARATION

Tool number (Kent-Moore No.) Tool name	Description
KV32102700 (—) a: 48 mm (1.89 in) dia. b: 41 mm (1.61 in) dia. Drift	Main drive gear ball bearing installation
ST23860000 (—) a: 38 mm (1.50 in) dia. b: 33 mm (1.30 in) dia. Drift	Reverse counter gear installation
ST01530000 (—) a: 50 mm (1.97 in) dia. b: 41 mm (1.61 in) dia. Drift	Reverse synchronizer assembly installation
ST35291000 (—) a: 40 mm (1.57 in) dia. b: 29.5 mm (1.161 in) dia. c: 22.5 mm (0.886 in) dia. Drift	Control shaft oil seal installation
KV40100630 (J26092) a: 67 mm (2.64 in) dia. b: 38 mm (1.50 in) dia. Inserter	<ul style="list-style-type: none"> ● 4th counter gear thrust washer installation ● 4th counter gear bushing installation
KV38102100 (J25803-01) a: 44 mm (2.36 in) dia. b: 28 mm (1.10 in) dia. Drift	Front cover oil seal installation
KV32103300 (J46529) Press plate	Reverse main gear installation

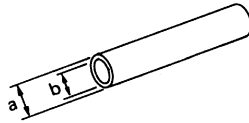

ZZA0534D

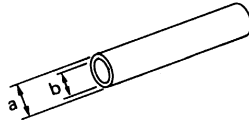

ZZA0534D

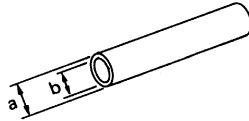

ZZA0534D

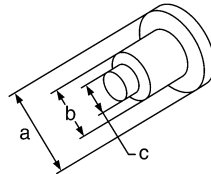

SCIA1575E

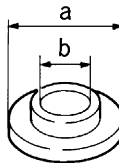

ZZA0920D

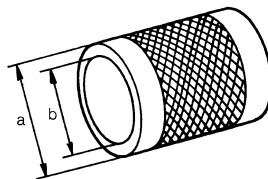

ZZA1002D

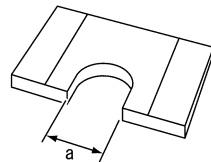

PCIB0165J

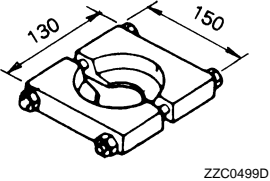
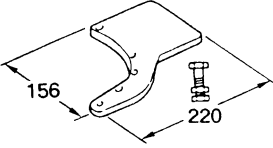

PREPARATION

Tool number (Kent-Moore No.) Tool name	Description	
ST30031000 (J22912-01) Puller	 <p style="text-align: right; margin-top: 5px;">ZZC0499D</p>	A B MT
ST224490000 (—) Adapter plate	 <p style="text-align: right; margin-top: 5px;">ZZC0465D</p>	D E F G H I J K L M

PREPARATION

Commercial Service Tools

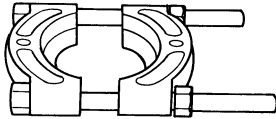
ACS003T9

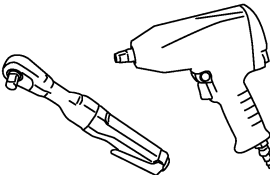
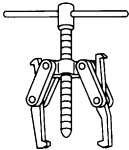
Tool name	Description
<p>Puller</p>  <p>ZZB0823D</p>	<p>Each bearing gear and bushing removal</p>
<p>Pin punch Tip diameter: 6.0 mm (0.24 in) dia.</p>  <p>ZZA0815D</p>	<p>Each retaining pin removal and installation</p>
<p>Power tool</p>  <p>PBIC0190E</p>	<p>Loosening bolts and nuts</p>
<p>Puller</p>  <p>NT077</p>	<p>Reverse synchronizer assembly removal Reverse counter gear removal Reverse main gear removal</p>

NOISE, VIBRATION AND HARSHNESS (NVH) TROUBLESHOOTING

NOISE, VIBRATION AND HARSHNESS (NVH) TROUBLESHOOTING

PFP:00003

NVH Troubleshooting Chart

ACS003TA

Use the chart below to help you find the cause of the symptom. The numbers indicate the order of the inspection. If necessary, repair or replace these parts.

MANUAL TRANSMISSION

Reference page	MT-10	MT-10	MT-10	MT-22	MT-22	MT-13	MT-2Z	MT-2Z	MT-23	MT-23	MT-23	MT-23
SUSPECTED PARTS (Possible cause)	OIL (Oil level is low.)	OIL (Wrong oil.)	OIL (Oil level is high.)	GASKET (Damaged)	OIL SEAL (Worn or damaged)	SHIFT CONTROL LINKAGE (Worn)	CHECK PLUG RETURN SPRING AND CHECK BALL (Worn or damaged)	SHIFT FORK (Worn)	GEAR (Worn or damaged)	BEARING (Worn or damaged)	BAULK RING (Worn or damaged)	INSERT SPRING (Damaged)
Symptoms	Noise	1	2						3	3		
	Oil leakage		3	1	2	2						
	Hard to shift or will not shift		1	1		2					2	2
	Jumps out of gear					1	1	2	2			

A
B
C
D
E
F
G
H
I
J
K
L
M

MT

DESCRIPTION

DESCRIPTION

PFP:00000

Cross-Sectional View

ACS003TR

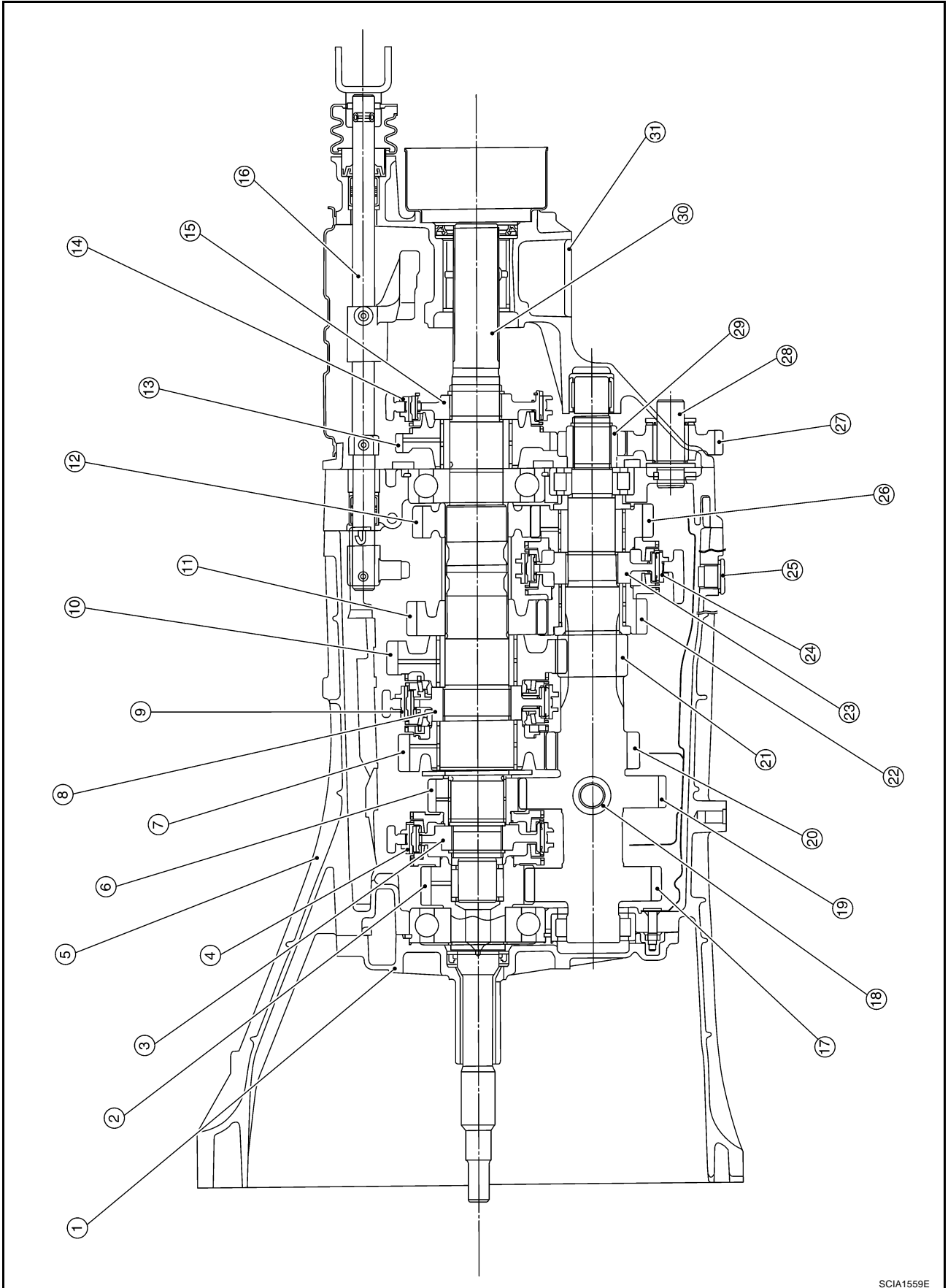

SCIA1559E

DESCRIPTION

- | | | |
|------------------------------|--------------------------------|-------------------------------|
| 1. Front cover | 2. Main drive gear (5th gear) | 3. 5th - 6th synchronizer hub |
| 4. 5th - 6th coupling sleeve | 5. Transmission case | 6. 6th main gear |
| 7. 2nd main gear | 8. 1st - 2nd synchronizer hub | 9. 1st - 2nd coupling sleeve |
| 10. 1st main gear | 11. 3rd main gear | 12. 4th main gear |
| 13. Reverse main gear | 14. Reverse coupling sleeve | 15. Reverse synchronizer hub |
| 16. Control rod | 17. Countershaft | 18. Filler plug |
| 19. 6th counter gear | 20. 2nd counter gear | 21. 1st counter gear |
| 22. 3rd counter gear | 23. 3rd - 4th synchronizer hub | 24. 3rd - 4th coupling sleeve |
| 25. Drain plug | 26. 4th counter gear | 27. Reverse idler gear |
| 28. Reverse idler shaft | 29. Reverse counter gear | 30. Mainshaft |
| 31. Rear extension case | | |

A
B
MT
D
E
F
G
H
I
J
K
L
M

DOUBLE-CONE SYNCHRONIZER (MODEL CODE NUMBER. CD000)

Double-cone synchronizer is adopted for 1st and 2nd gear to reduce operating force of the shift lever.

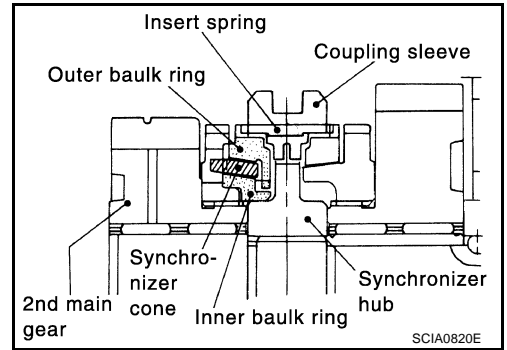

DOUBLE-CONE SYNCHRONIZER (MODEL CODE NUMBER. CD005)

The 1st and 3rd, 4th gears is equipped with a double-cone synchronizer to reduce the operating force of the shift lever as shown.

TRIPLE-CONE SYNCHRONIZER (MODEL CODE NUMBER. CD005)

The 2nd gear is equipped with a triple-cone synchronizer to reduce the operating force of the shift lever as shown.

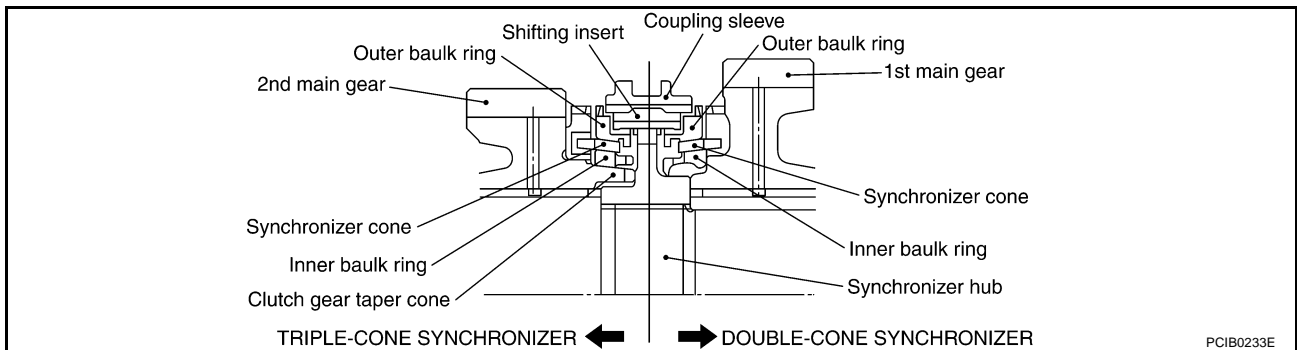

M/T OIL

Replacement DRAINING

1. Start the engine and warm up the transmission unit sufficiently.
2. After stopping engine, remove filler plug and drain plug and then drain fluid.
3. After replace a new gasket on drain plug, screw drain plug into transmission body and tighten to the specified torque.

Drain plug:

 : 30 - 39 N-m (3.1 - 3.9 kg-m, 23 - 28 ft-lb)

CAUTION:

Gaskets are not reusable. Never reuse them.

FILLING

1. Remove filler plug. Fill new oil into the transmission to the level of the filler plug mounting hole.

Oil grade: API GL-4

Viscosity: Refer to [MA-11, "RECOMMENDED FLUIDS AND LUBRICANTS"](#) .

Oil capacity: Approx. 2.9 ℓ (3-1/4 US qt, 2-3/4 Imp qt)

2. After filling, check fluid level, replace a new gasket on filler plug, screw filler plug into transmission body, and tighten to the specified torque.

Filler plug:

 : 30 - 39 N-m (3.1 - 3.9 kg-m, 23 - 28 ft-lb)

CAUTION:

Gaskets are not reusable. Never reuse them.

Checking

OIL LEAKAGE AND OIL LEVEL

ACS0037D

- Check if oil is leaking from transmission or around it.
- Check oil level from filler plug mounting hole as shown in the figure.

CAUTION:

Never start engine while checking oil level.

- When screwing in filler plug with a new gasket, first screw into the transmission by hand, then tighten to the specified torque.

Filler plug:

 : 30 - 39 N-m (3.1 - 3.9 kg-m, 23 - 28 ft-lb)

CAUTION:

Gaskets are not reusable. Never reuse them.

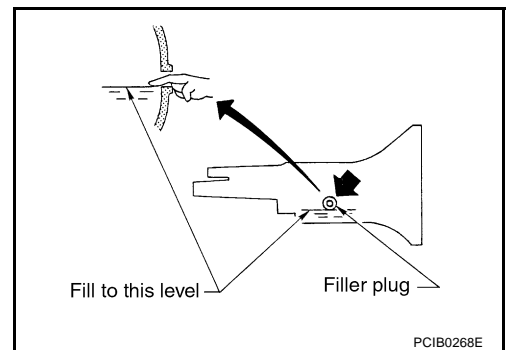

REAR OIL SEAL

REAR OIL SEAL

PFP:33140

Removal and Installation

ACS003TE

REMOVAL

1. Remove propeller shaft. Refer to [PR-7, "REMOVAL"](#).

CAUTION:

Do not impact or damage propeller shaft tube.

2. Using oil seal puller, remove oil seal.

Tool number : KV381054S0 (—)

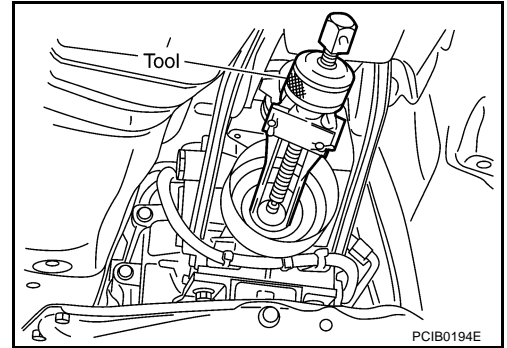

INSTALLATION

1. Apply multi-purpose grease to oil seal lip. Using a drift, drive in oil seal until the edge is approximately 1.2 - 2.2 mm (0.047 - 0.087 in) above the boss edge.

Tool number : ST33400001 (J26082)

CAUTION:

- Oil seals are not reusable. Never reuse them.
- When installing, do not incline the oil seal.

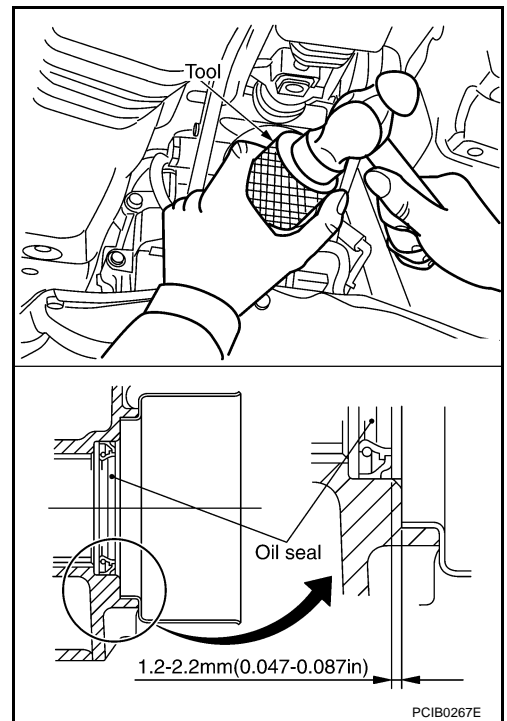

2. Install propeller shaft. Refer to [PR-8, "INSTALLATION"](#).

CAUTION:

- Do not impact or damage propeller shaft tube.
- If lubricant leak has occurred, after finishing work, check oil level. Refer to [MT-10, "Checking"](#).

POSITION SWITCH

POSITION SWITCH

PFP:32005

Checking COMPONENT LOCATION

ACS003TF

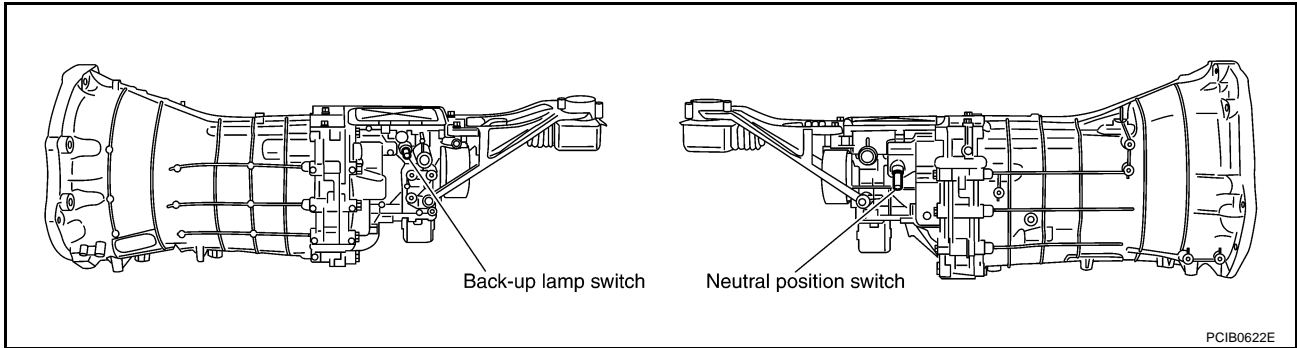

BACK-UP LAMP SWITCH

- Check continuity.

Gear position	Continuity
Reverse	Yes
Except reverse	No

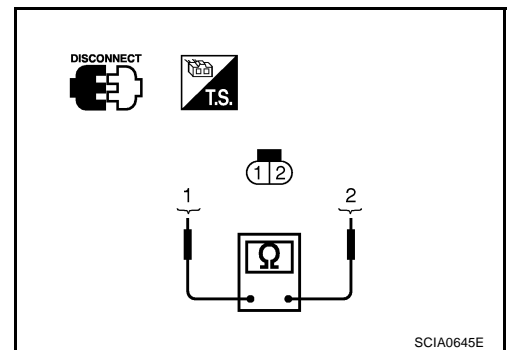

NEUTRAL POSITION SWITCH

- Check continuity.

Gear position	Continuity
Neutral	Yes
Except neutral	No

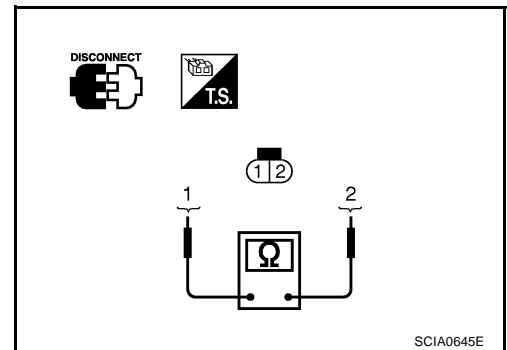

SHIFT CONTROL

SHIFT CONTROL

PPF:34103

Removal and Installation of Control Lever Assembly

ACS0037G

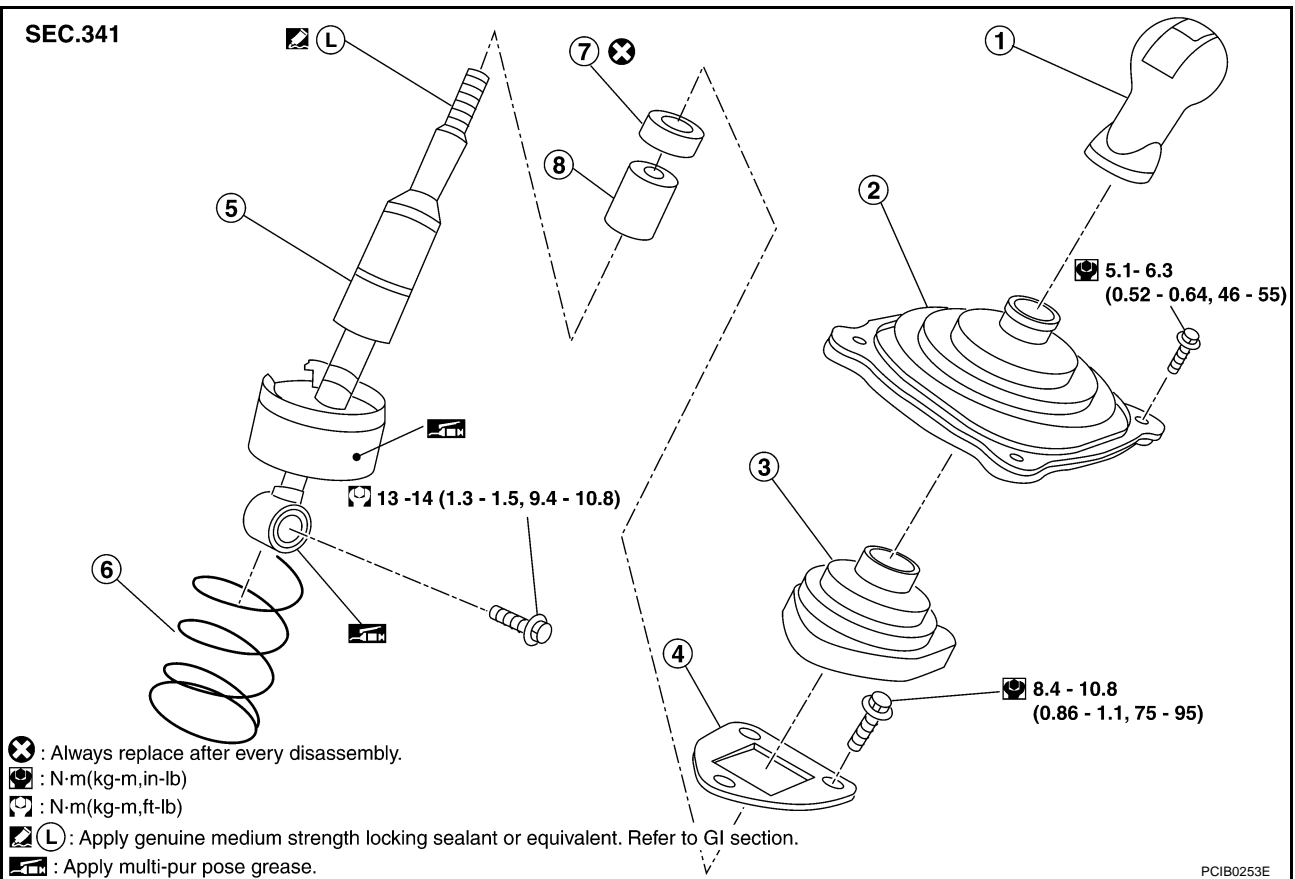

- | | | |
|----------------|------------------|-------------------------|
| 1. Shift knob | 2. Hole cover | 3. Control lever boot |
| 4. Guide plate | 5. Control lever | 6. Control lever spring |
| 7. Insulator | 8. Seat | |

REMOVAL

1. Remove the shift knob with the following procedure.
 - a. Disconnect console boot from center console. Refer to [IP-10, "INSTRUMENT PANEL ASSEMBLY"](#)

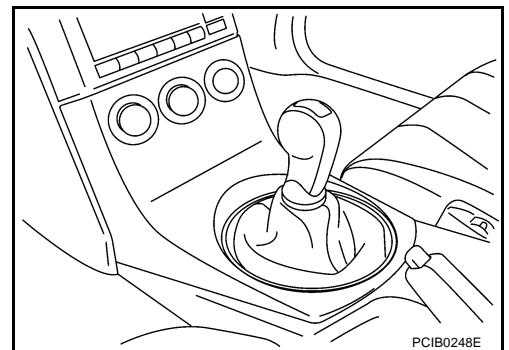

A
B
MT
D
E
F
G
H
I
J
K
L
M

SHIFT CONTROL

- b. Lift console boot, and push down hole cover. set water pump plier and others to control lever assembly.

CAUTION:

Put waste cloth between water pump plier and control lever assembly to avoid damaging control lever assembly.

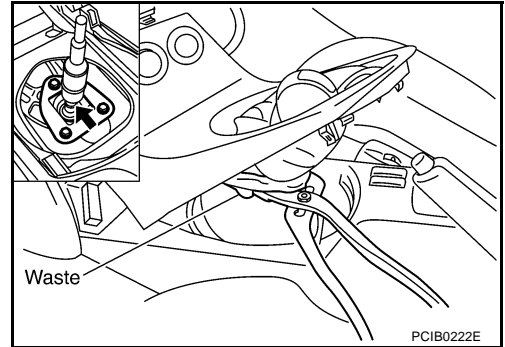

- c. Set monkey wrench to shift knob.

CAUTION:

Put waste cloth between shift knob and suitable plier to avoid damaging shift knob.

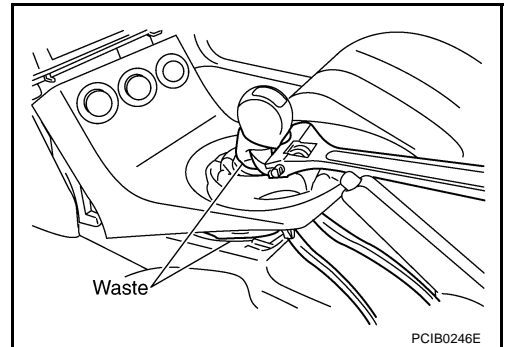

- d. Turn monkey wrench with water pump plier and others fixed. Loosen shift knob, and remove shift knob from control lever assembly.

NOTE:

Remove shift knob from control assembly with water pump plier and others fixed. Because a certain power to turn shift knob is necessary even after adhesive is peeled.

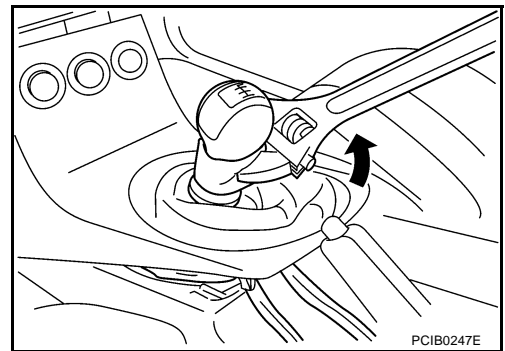

2. Loosen the shift knob to remove the control lever.
3. Remove console boot. Refer to [IP-11, "Removal and Installation"](#).
4. Push back the boot, remove control lever assembly mounting bolt, and separate control lever and control rod assembly.

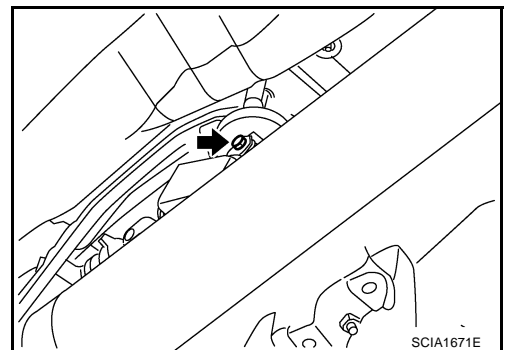

SHIFT CONTROL

5. Remove the mounting bolts to remove the hole cover.
6. Remove the control lever boot.

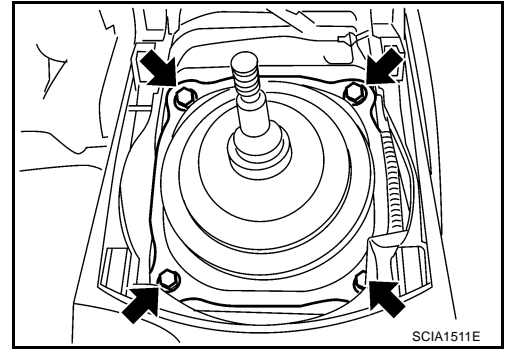

7. Remove guide plate mounting bolts, and then remove control lever assembly and control lever spring.

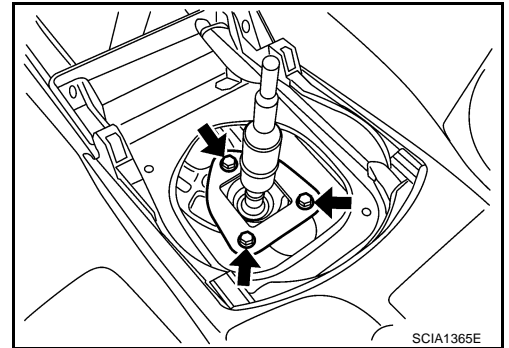

INSTALLATION

1. Set control lever assembly and control lever spring in the control lever housing assembly and loosely mount the guide plate.
2. After installing control lever assembly in the control rod assembly, tighten bolts to the specified torque.

 : 13 - 14 N·m (1.3 - 1.5 kg·m, 9.4 - 10.8 ft·lb)

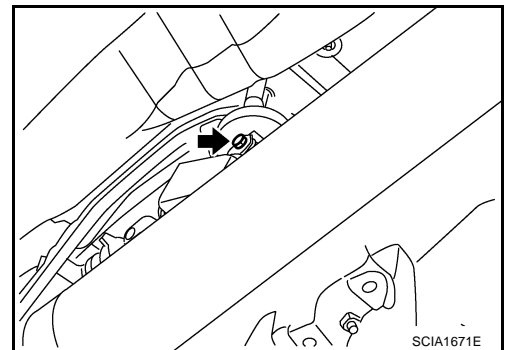

A
B
MT
D
E
F
G
H
I
J
K
L
M

SHIFT CONTROL

3. Shifting control lever assembly to 6th gear, the control lever assembly is light pressed to the reverse side.
4. At the point where the control lever assembly stops, bring the guide plate closer until guide plate stopper contacts control lever assembly claw, and then loosely tighten mounting bolt A.

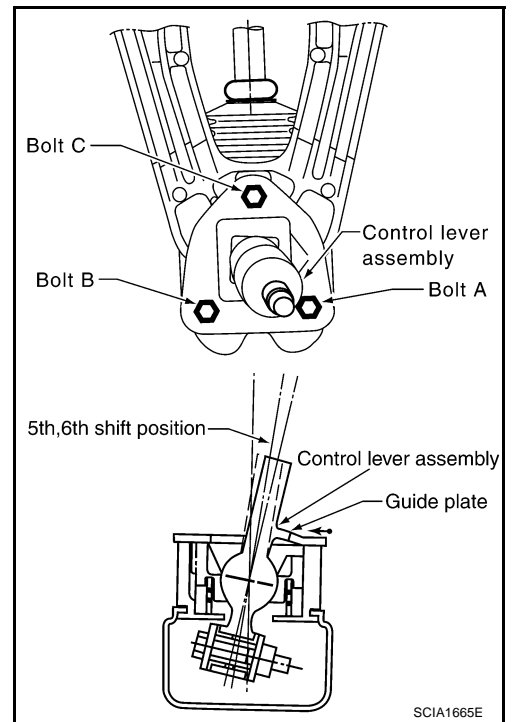

5. Shifting control lever assembly to 5th gear, the control lever assembly light pressed to the reverse side.
6. At the point where control lever assembly stops, bring guide plate closer until the guide plate stopper contacts control lever assembly claw, and then loosely tighten mounting bolt C.

 : 8.4 - 10 N·m (0.86 - 1.0 kg-m, 75 - 88 in-lb)

7. Tighten guide plate bolts A and B to the specified torque.

 : 8.4 - 10 N·m (0.86 - 1.0 kg-m, 75 - 88 in-lb)

8. Install control lever boot.

9. Install hole cover.

 : 5.1 - 6.3 N·m (0.52 - 0.64 kg-m, 46 - 55 in-lb)

10. Install console finisher. Refer to [IP-11, "Removal and Installation"](#).

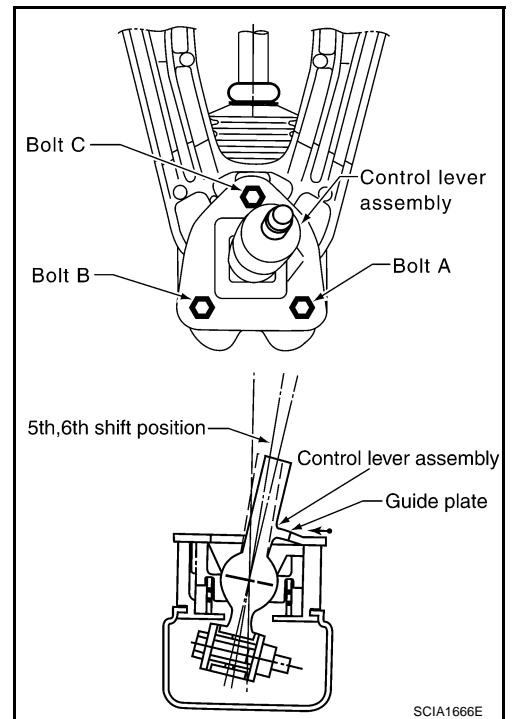

11. As shown in the figure, assemble seat and insulator to control lever assembly.

CAUTION:
Do not reuse the insulator.

12. Apply locking sealant to control lever threads, install shift knob.

CAUTION:
Remove the remaining adhesive on control lever and shift knob threads.

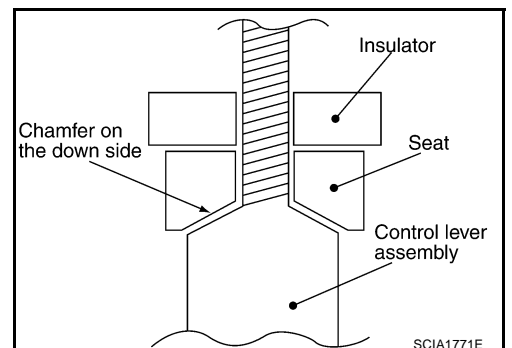

SHIFT CONTROL

13. Put the shift knob in the correct position as the following indicates.

- a. When tightening shift knob, if shift knob position is the correct position a less than 1/2 rotation from starting resistance, tighten 1 more rotation and set the correct position again.
- b. If shift knob position is the correct position more than 1/2 rotation from starting resistance, tighten and set the correct position.

CAUTION:

- Do not adjust the knob with loosing.
- After adjusting to regular position, until 30 minute passes since a locking sealant because stiff. Do not operate the shift intensely such as screwing or turning the shift knob to opposite direction.

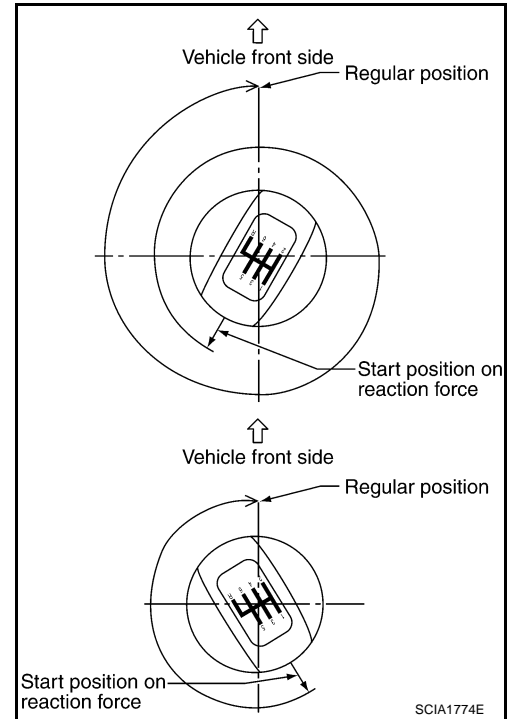

INSPECTION AFTER INSTALLATION

After installing, confirm the following items:

- When control lever assembly is shifted to each position, make sure there is no binding or disconnection in each boot.
- When shifted to each position, make sure there is no noise, bending, and backlash. Especially when control lever assembly is shifted to 5th, 6th without pressing downward, check for bending.
- When control lever assembly is shifted to 1st, 2nd side and 5th, 6th side, confirm control lever assembly returns to neutral position smoothly.
- In any position other than reverse, confirm that control lever assembly can be pressed downward.
- With control lever assembly pressed downward, confirm that it can be shifted to reverse.
- When shifted from reverse to neutral position, confirm control lever assembly returns to neutral position smoothly with spring power.
- Without control lever assembly pressed downward, confirm that it cannot be shifted to reverse.

AIR BREATHER HOSE

AIR BREATHER HOSE

PFP:31098

Removal and Installation

ACS003TH

Refer to the figure for air breather hose removal and installation information.

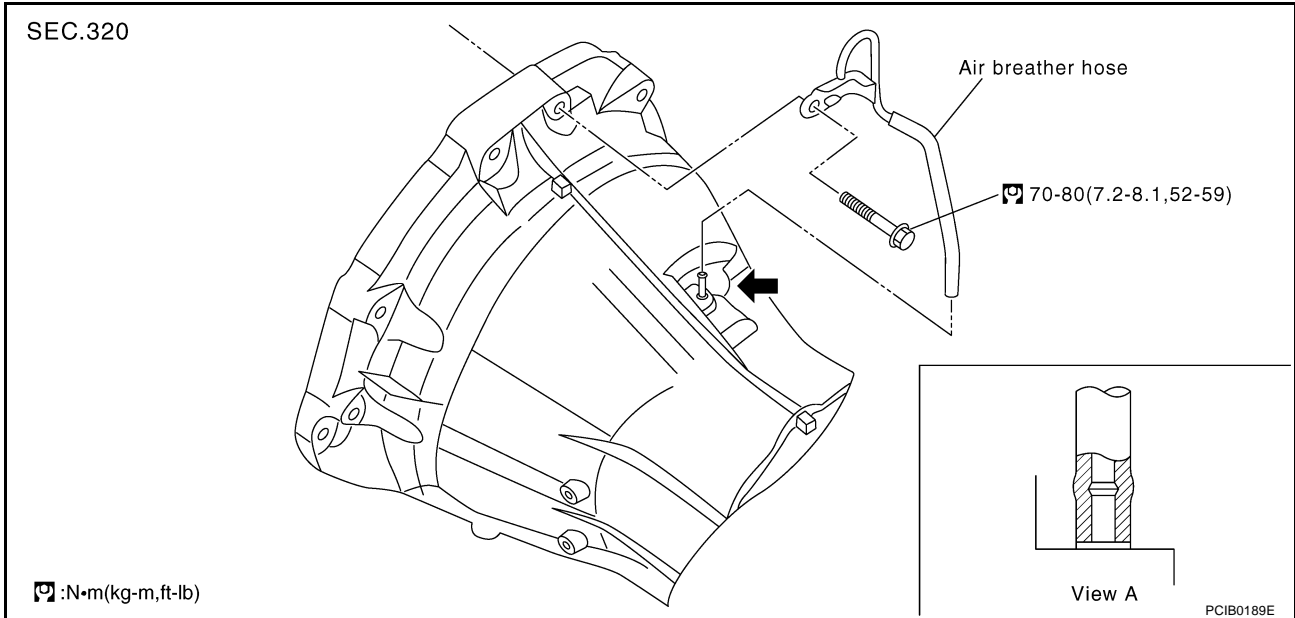

CAUTION:

- Make sure there are no pinched or blocked areas on the air breather hose caused by bending or winding when installing it.
- Be sure to insert the hose until the overlap area reaches the tube edge or the pressing part of spool, insulator, etc.

TRANSMISSION ASSEMBLY

TRANSMISSION ASSEMBLY

PF3:32010

Removal and Installation from Vehicle

ACS0037I

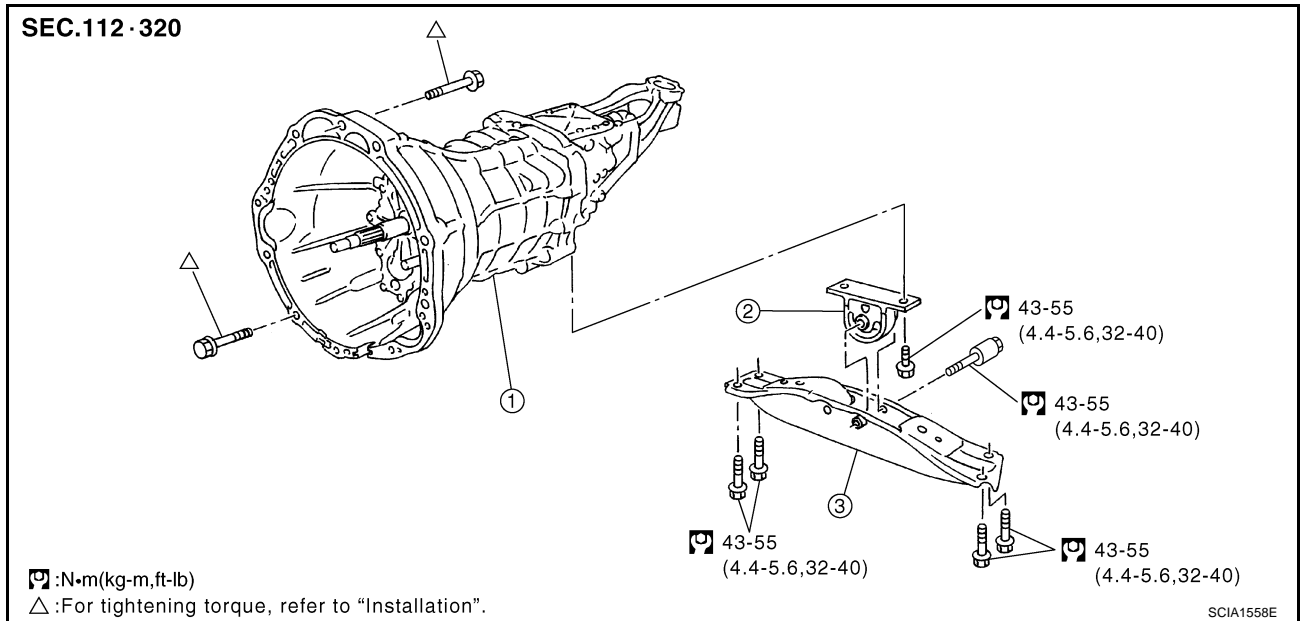

1. Transmission case

2. Insulator

3. Rear engine mounting member

REMOVAL

1. Disconnect battery negative cable.
2. Remove tower bar.
3. Remove front cross bar with power tool. Refer to [FSU-9, "Removal and Installation"](#).
4. Remove catalytic converter stay mounting nuts and bolts, and then remove catalytic converter bracket. Refer to [EX-3, "Removal and Installation"](#).

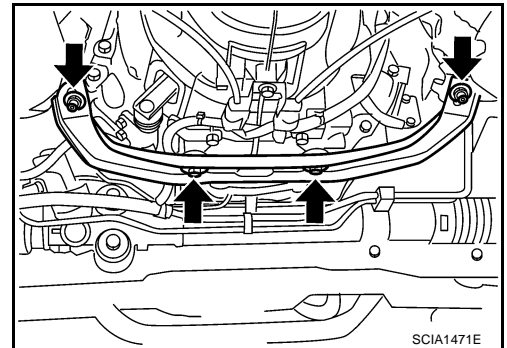

5. Remove nut connecting catalytic converter to exhaust manifold, and then remove catalytic converter and exhaust front tube as one unit.
6. Remove propeller shaft. Refer to [PR-7, "REMOVAL"](#).

CAUTION:

Do not impact or damage propeller shaft tube.

7. Remove control rod mounting bolts and then separate shift lever assembly from the control rod assembly.

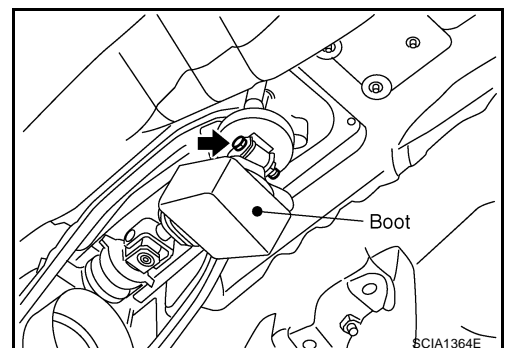

TRANSMISSION ASSEMBLY

8. Using a screwdriver wrapped in tape to remove claw and then separate console finisher from the center console. Refer to [IP-11, "Removal and Installation"](#).

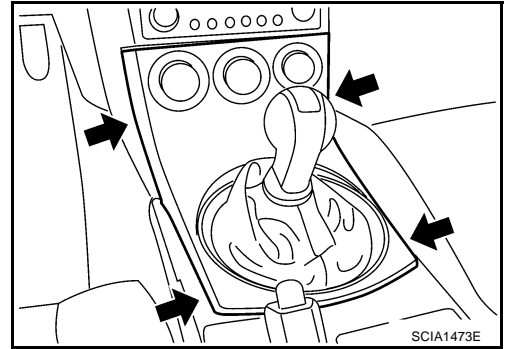

9. Remove hole cover mounting bolts and then separate hole cover from the floor panel.
10. Separate control lever boot from the guide plate.

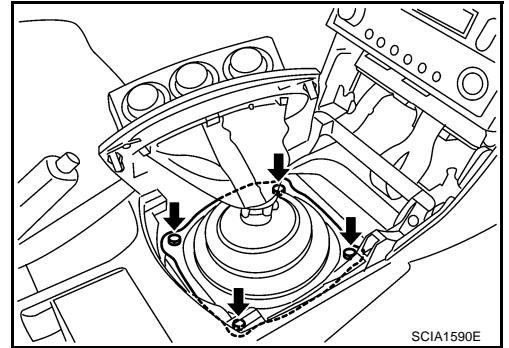

11. Remove guide plate mounting bolts and then separate shift lever assembly from the shift lever housing assembly.

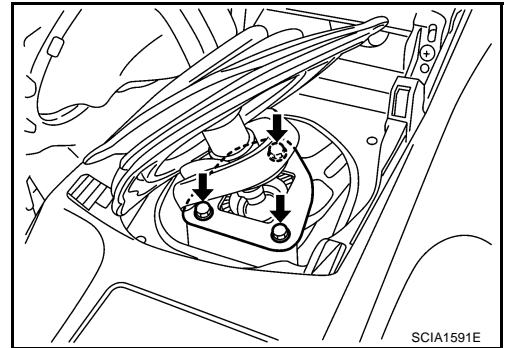

12. Remove clutch operating cylinder mounting bolts and then separate clutch operating cylinder from the transmission case.

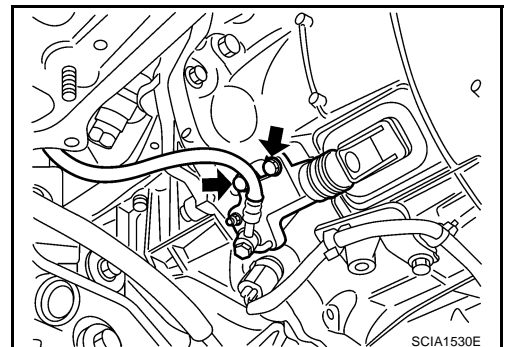

13. Remove crankshaft position sensor (POS).

CAUTION:

- Do not subject it to impact by dropping or hitting.
- Do not disassemble.
- Do not allow metal filings, etc., to get on the sensor's front edge magnetic area.
- Do not place in an area affected by magnetism.

14. Disconnect neutral switch and reverse switch.

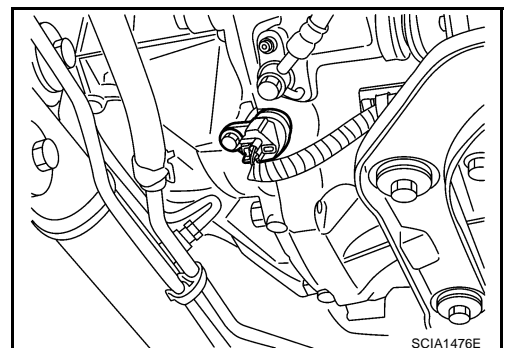

TRANSMISSION ASSEMBLY

15. Separate heated oxygen sensor 2 wire harness, crankshaft position sensor (POS). wire harness, back-up lamp switch wire harness, PNP switch wire harness from the transmission.
16. Remove starter motor. Refer to [SC-19, "Removal and Installation"](#) .
17. Set transmission jack to the transmission.

CAUTION:

When setting transmission jack, be careful not to contact with the switch.

18. Remove rear engine mounting member. Refer to [EM-90, "Removal and Installation"](#) .
19. Remove engine and transmission mounting bolts with power tool.
20. Remove transmission from the vehicle.

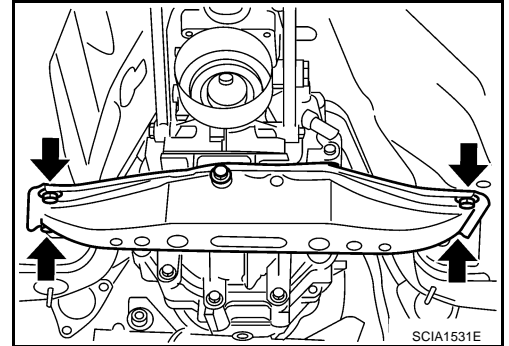

INSTALLATION

Install in the reverse order of removal procedure, following the cautions below:

- When installing transmission to the engine, install mounting bolts in accordance with the standards below.

Bolt No.	1	2	3	4
Quantity	1	5	2	2
"ℓ" mm (in)	55 (2.17)	65 (2.56)	56 (1.97)	35 (1.38)
Tightening torque N-m (kg-m, ft-lb)	70 - 80 (7.1 - 8.1, 52 - 59)		49 - 61 (5.0 - 6.2, 37 - 44)	42 - 52 (4.3 - 5.3, 31 - 38)

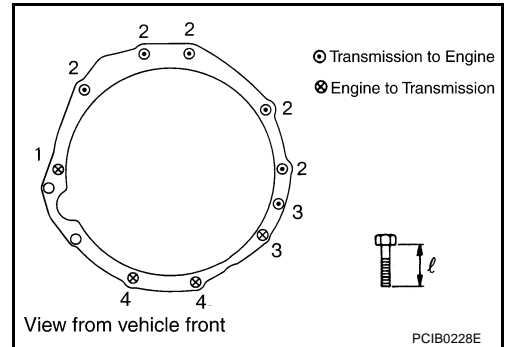

CAUTION:

- When installing, be careful to avoid interference between transmission main drive shaft and clutch cover.
- Do not impact or damage propeller shaft tube.
- Refer to [MT-15, "INSTALLATION"](#) and [MT-17, "INSPECTION AFTER INSTALLATION"](#) for control lever installation information.
- After installation, check oil level, and oil leaks and loose mechanisms.

TRANSMISSION ASSEMBLY

ACS003TJ

Component Parts Drawing CASE COMPONENTS

SEC.321

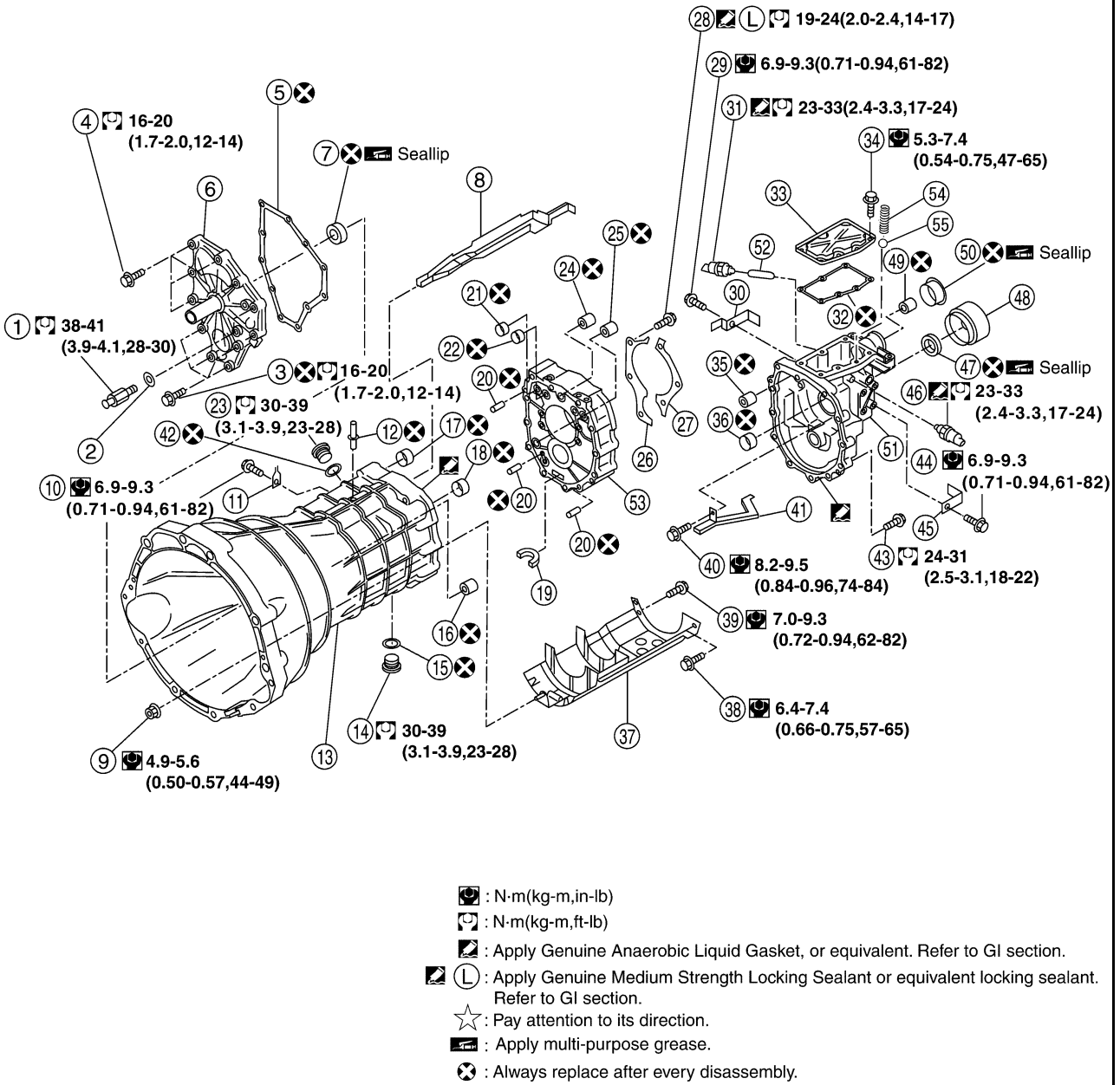

PCIB0216E

- | | | |
|------------------------------|---------------------------------------|--------------------------------------|
| 1. Withdrawal lever ball pin | 2. Washer | 3. Bolt |
| 4. Bolt | 5. Front cover gasket | 6. Front cover |
| 7. Front cover oil seal | 8. Oil gutter | 9. Nut |
| 10. Bolt | 11. Bracket | 12. Breather |
| 13. Transmission case | 14. Drain plug | 15. Gasket |
| 16. Sliding ball bearing | 17. Bushing | 18. Bushing |
| 19. Magnet | 20. Dowel pin | 21. Bushing |
| 22. Bushing | 23. Filler plug | 24. Sliding ball bearing |
| 25. Sliding ball bearing | 26. Main shaft bearing retainer plate | 27. Mainshaft bearing retainer plate |
| 28. Bolt | 29. Bolt | 30. Bracket |
| 31. Neutral position switch | 32. Rear extension upper cover gasket | 33. Rear extension upper cover |

TRANSMISSION ASSEMBLY

- | | | |
|--------------------------|-------------------------------|-------------------------------|
| 34. Bolt | 35. Sliding ball bearing | 36. Bushing |
| 37. Baffle plate | 38. Bolt | 39. Bolt |
| 40. Bolt | 41. Rear extension oil gutter | 42. Gasket |
| 43. Bolt | 44. Bolt | 45. Bracket |
| 46. Reverse switch | 47. Rear oil seal | 48. Rear extension dust cover |
| 49. Sliding ball bearing | 50. Control shaft oil seal | 51. Rear extension case |
| 52. Plunger | 53. Adapter plate | 54. Check select spring |
| 55. Check ball | | |

GEAR COMPONENTS (MODEL CODE NUMBER. CD000)

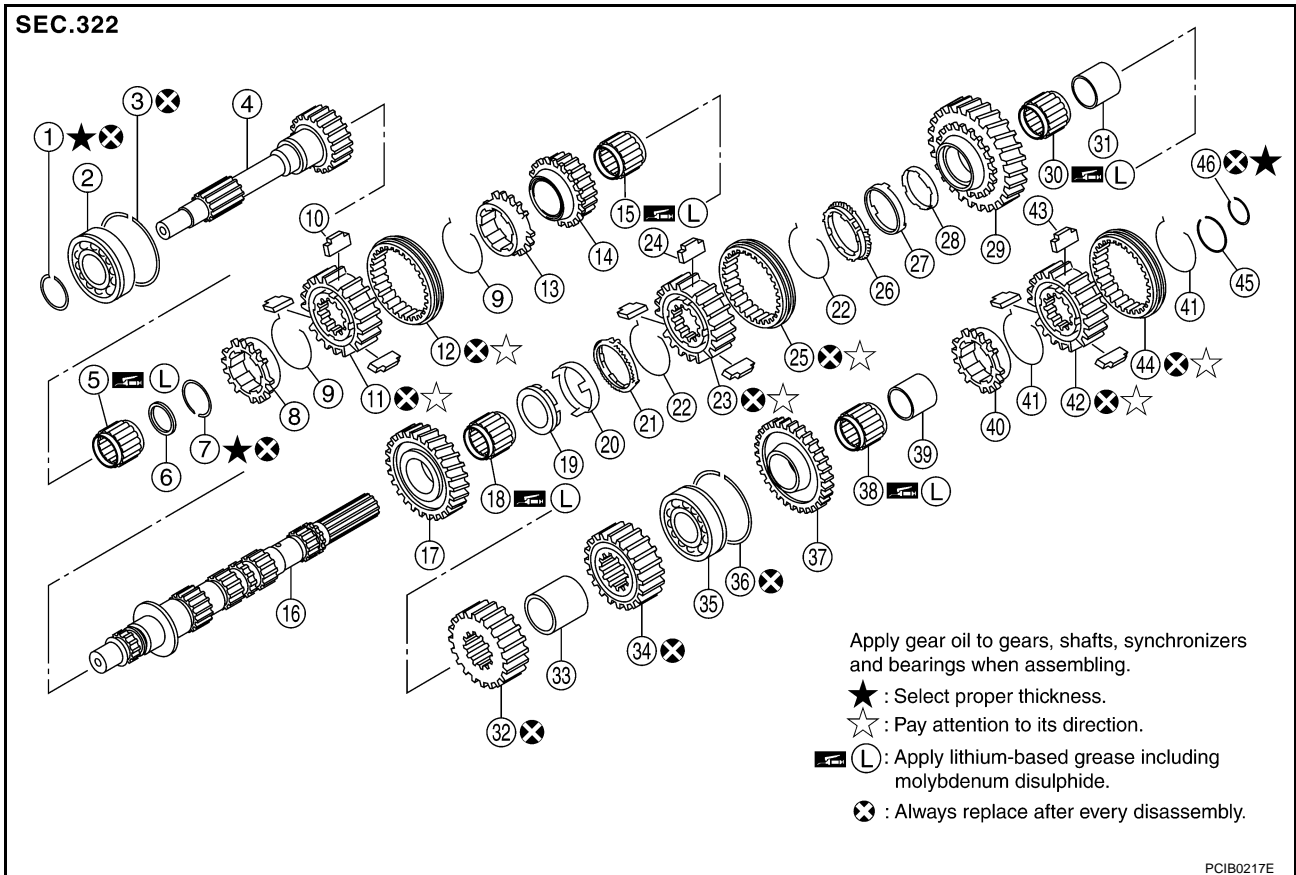

- | | | |
|-------------------------------|---------------------------------|--------------------------------|
| 1. Snap ring | 2. Main drive gear bearing | 3. Snap ring |
| 4. Main drive gear (5th gear) | 5. Main pilot bearing | 6. Pilot bearing spacer |
| 7. Snap ring | 8. 5th gear baulk ring | 9. 5th - 6th spread spring |
| 10. 5th - 6th shifting insert | 11. 5th - 6th synchronizer hub | 12. 5th - 6th coupling sleeve |
| 13. 6th gear baulk ring | 14. 6th main gear | 15. 6th needle bearing |
| 16. Mainshaft | 17. 2nd main gear | 18. 2nd needle bearing |
| 19. 2nd gear inner baulk ring | 20. 2nd gear synchronizer cone | 21. 2nd gear outer baulk ring |
| 22. 1st - 2nd spread spring | 23. 1st - 2nd synchronizer hub | 24. 1st - 2nd shifting insert |
| 25. 1st - 2nd coupling sleeve | 26. 1st gear outer baulk ring | 27. 1st gear synchronizer cone |
| 28. 1st gear inner baulk ring | 29. 1st main gear | 30. 1st needle bearing |
| 31. 1st gear bushing | 32. 3rd main gear | 33. 3rd - 4th main spacer |
| 34. 4th main gear | 35. Mainshaft bearing | 36. Snap ring |
| 37. Reverse main gear | 38. Reverse main needle bearing | 39. Reverse main gear bushing |
| 40. Reverse baulk ring | 41. Reverse spread spring | 42. Reverse synchronizer hub |
| 43. Reverse shifting insert | 44. Reverse coupling sleeve | 45. Snap ring |
| 46. Snap ring | | |

TRANSMISSION ASSEMBLY

SEC.322

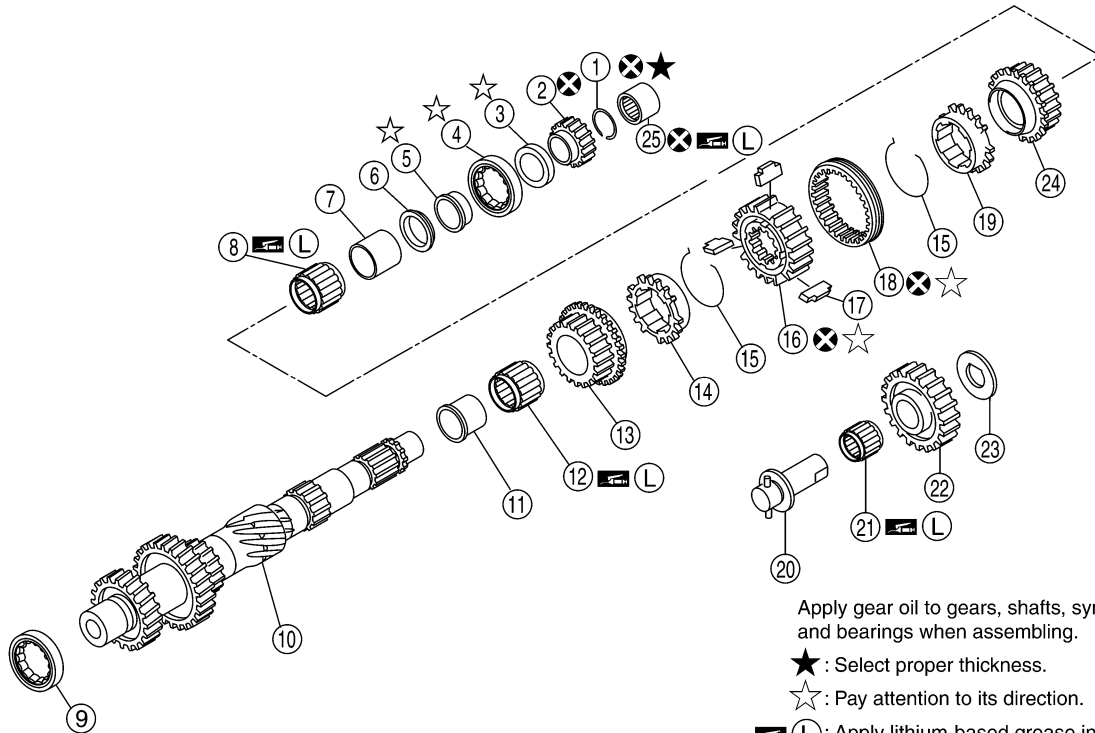

Apply gear oil to gears, shafts, synchronizers and bearings when assembling.

★ : Select proper thickness.

☆ : Pay attention to its direction.

L : Apply lithium-based grease including molybdenum disulphide.

X : Always replace after every disassembly.

PCIB0462E

- | | | |
|--------------------------------|------------------------------------|-----------------------------------|
| 1. Snap ring | 2. Reverse counter gear | 3. Counter rear bearing spacer |
| 4. Counter rear bearing | 5. Counter rear bearing inner race | 6. 4th counter gear thrust washer |
| 7. 4th gear bushing | 8. 4th needle bearing | 9. Counter front bearing |
| 10. Countershaft | 11. 3rd gear bushing | 12. 3rd needle bearing |
| 13. 3rd counter gear | 14. 3rd gear baulk ring | 15. 3rd - 4th spread spring |
| 16. 3rd - 4th synchronizer hub | 17. 3rd - 4th shifting insert | 18. 3rd - 4th coupling sleeve |
| 19. 4th gear baulk ring | 20. Reverse idler shaft | 21. Reverse idler needle bearing |
| 22. Reverse idler gear | 23. Reverse idler thrust washer | 24. 4th counter gear |
| 25. Counter end bearing | | |

TRANSMISSION ASSEMBLY

GEAR COMPONENTS (MODEL CODE NUMBER. CD005)

SEC.322

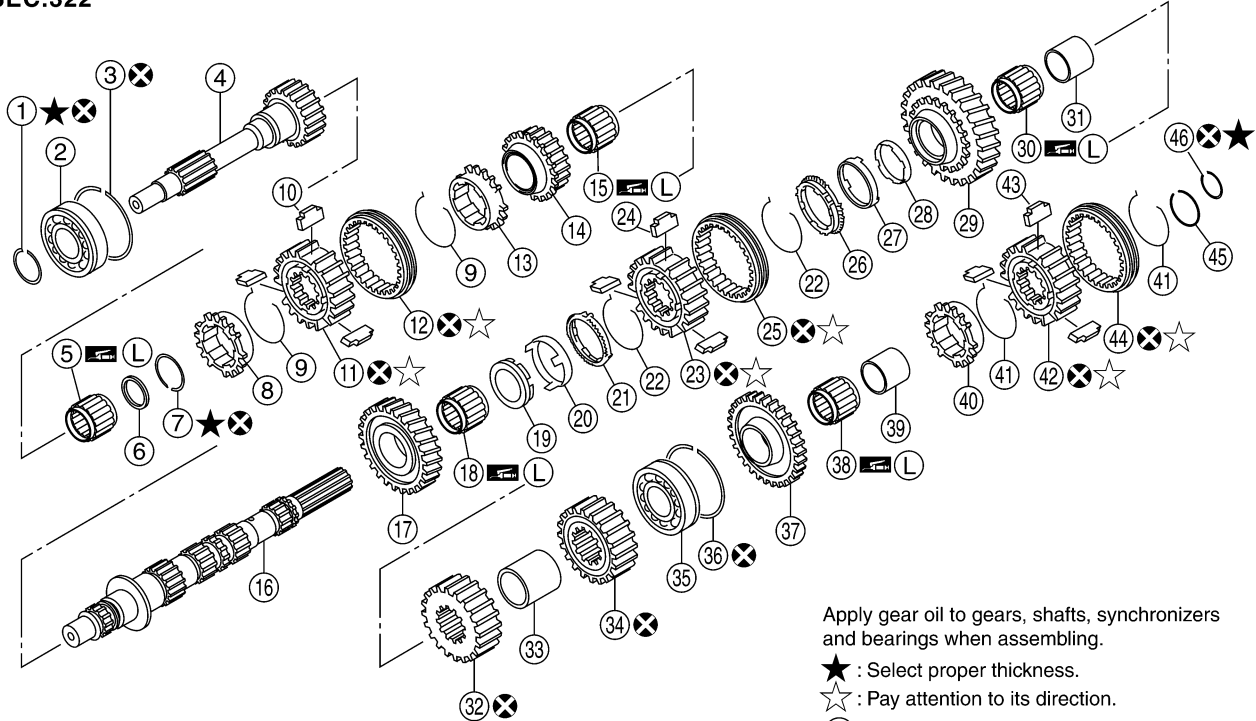

Apply gear oil to gears, shafts, synchronizers and bearings when assembling.

★ : Select proper thickness.

☆ : Pay attention to its direction.

L : Apply lithium-based grease including molybdenum disulphide.

⊗ : Always replace after every disassembly.

PCIB0217E

- | | | |
|-------------------------------|---------------------------------|--------------------------------|
| 1. Snap ring | 2. Main drive gear bearing | 3. Snap ring |
| 4. Main drive gear (5th gear) | 5. Main pilot bearing | 6. Pilot bearing spacer |
| 7. Snap ring | 8. 5th gear baulk ring | 9. 5th - 6th spread spring |
| 10. 5th - 6th shifting insert | 11. 5th - 6th synchronizer hub | 12. 5th - 6th coupling sleeve |
| 13. 6th gear baulk ring | 14. 6th main gear | 15. 6th needle bearing |
| 16. Main shaft | 17. 2nd main gear | 18. 2nd needle bearing |
| 19. 2nd gear inner baulk ring | 20. 2nd gear synchronizer cone | 21. 2nd gear outer baulk ring |
| 22. 1st - 2nd spread spring | 23. 1st - 2nd synchronizer hub | 24. 1st - 2nd shifting insert |
| 25. 1st - 2nd coupling sleeve | 26. 1st gear outer baulk ring | 27. 1st gear synchronizer cone |
| 28. 1st gear inner baulk ring | 29. 1st main gear | 30. 1st needle bearing |
| 31. 1st gear bushing | 32. 3rd main gear | 33. 3rd - 4th main spacer |
| 34. 4th main gear | 35. Main shaft bearing | 36. Snap ring |
| 37. Reverse main gear | 38. Reverse main needle bearing | 39. Reverse main gear bushing |
| 40. Reverse baulk ring | 41. Reverse spread spring | 42. Reverse synchronizer hub |
| 43. Reverse shifting insert | 44. Reverse coupling sleeve | 45. Snap ring |
| 46. Snap ring | | |

A
B
MT
D
E
F
G
H
I
J
K
L
M

TRANSMISSION ASSEMBLY

SEC.322

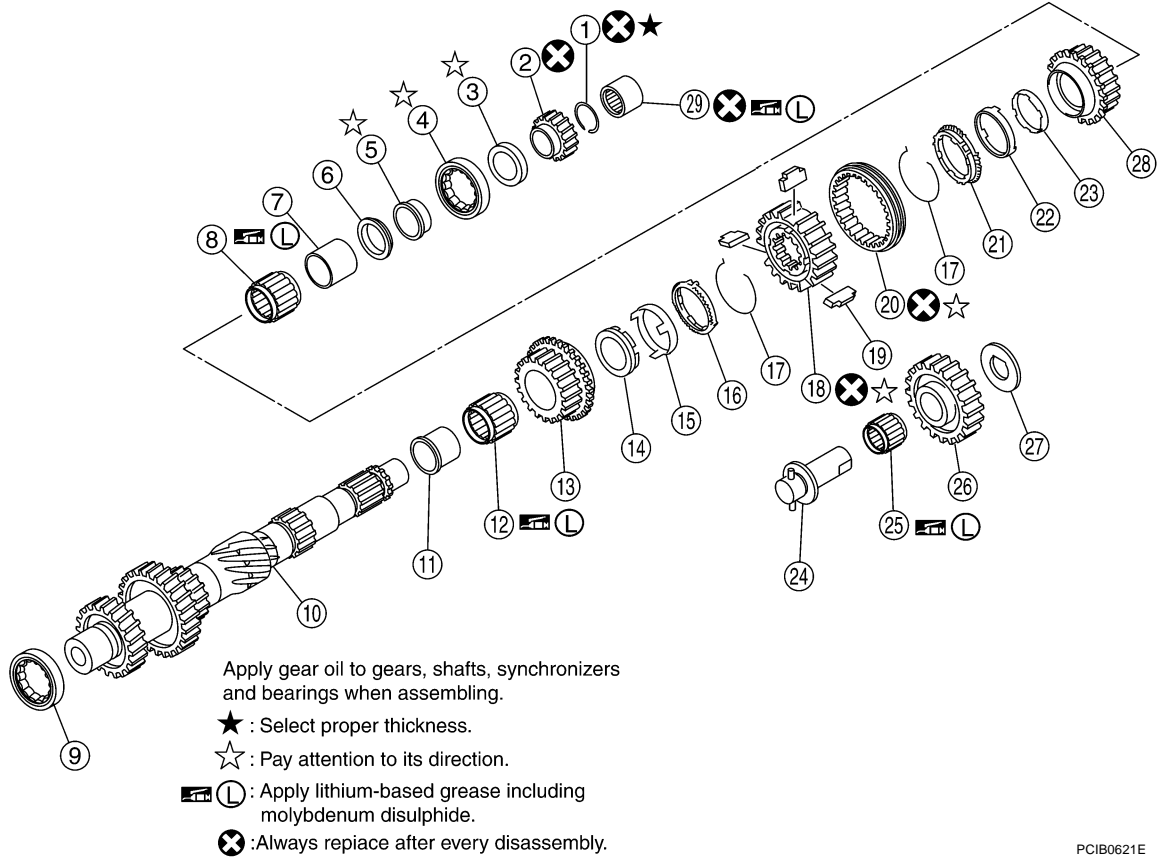

PCIB0621E

- | | | |
|----------------------------------|------------------------------------|-----------------------------------|
| 1. Snap ring | 2. Reverse counter gear | 3. Counter rear bearing spacer |
| 4. Counter rear bearing | 5. Counter rear bearing inner race | 6. 4th counter gear thrust washer |
| 7. 4th gear bushing | 8. 4th needle bearing | 9. Counter front bearing |
| 10. Counter shaft | 11. 3rd gear bushing | 12. 3rd needle bearing |
| 13. 3rd counter gear | 14. 3rd inner baulk ring | 15. 3rd synchronizer cone |
| 16. 3rd outer baulk ring | 17. 3rd - 4th spread spring | 18. 3rd - 4th synchronizer hub |
| 19. 3rd - 4th shifting insert | 20. 3rd - 4th coupling sleeve | 21. 4th outer baulk ring |
| 22. 4th synchronizer cone | 23. 4th inner baulk ring | 24. Reverse idler shaft |
| 25. Reverse idler needle bearing | 26. Reverse idler gear | 27. Reverse idler thrust washer |
| 28. 4th counter gear | 29. Counter end bearing | |

TRANSMISSION ASSEMBLY

SHIFT CONTROL COMPONENTS

SEC.322

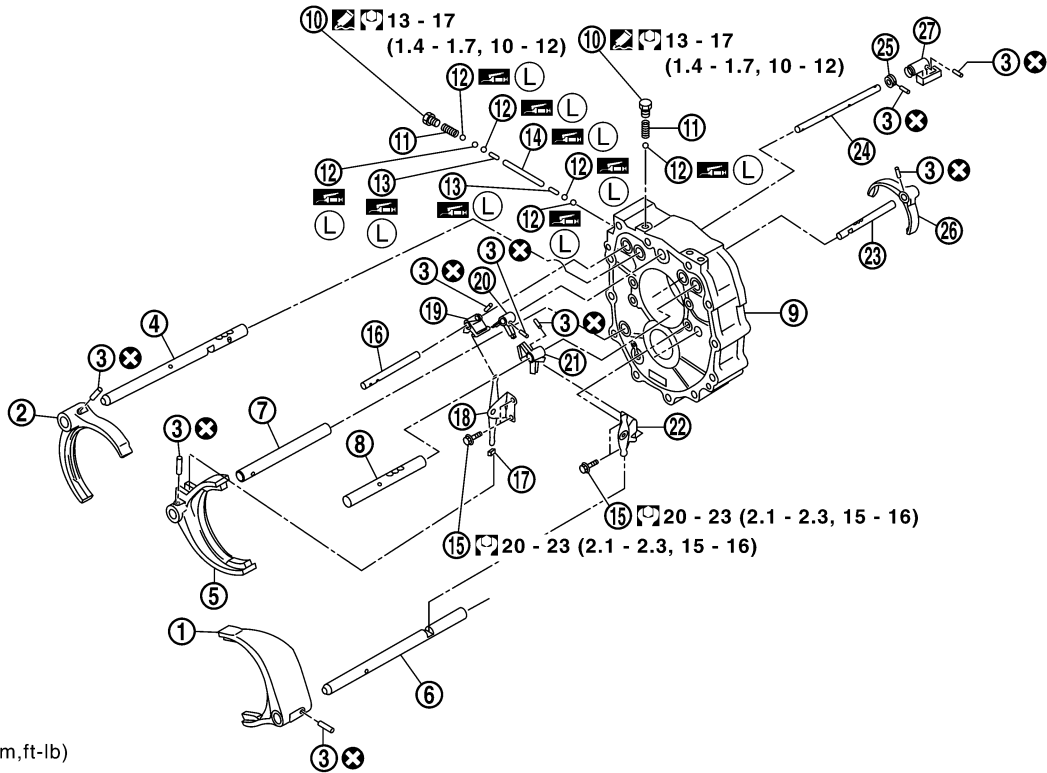

:N·m(kg-m,ft-lb)

: Apply Genuine Anaerobic Liquid Gasket, or equivalent. Refer to GI section.

(L) : Apply lithium-based grease including molybdenum disulphide.

: Always replace after every disassembly.

PCIB0218E

- | | | |
|---------------------------------------|-------------------------|---------------------------------------|
| 1. 5th - 6th shift fork | 2. 1st - 2nd shift fork | 3. Retaining pin |
| 4. 1st - 2nd fork rod | 5. 3rd - 4th shift fork | 6. 5th - 6th fork rod (reversal side) |
| 7. 3rd - 4th fork rod (reversal side) | 8. 5th - 6th fork rod | 9. Adapter plate |
| 10. Check ball plug | 11. Check ball spring | 12. Check ball |
| 13. Interlock pin | 14. Interlock plunger | 15. Bolt |
| 16. 3rd - 4th fork rod | 17. Shifter cap | 18. 3rd - 4th control lever |
| 19. 3rd - 4th fork rod bracket | 20. Striking lever | 21. 5th - 6th fork rod bracket |
| 22. 5th - 6th control lever | 23. Reverse fork rod | 24. Striking rod |
| 25. Stopper ring | 26. Reverse shift fork | 27. Low/high control lever |

A
B
MT
D
E
F
G
H
I
J
K
L
M

TRANSMISSION ASSEMBLY

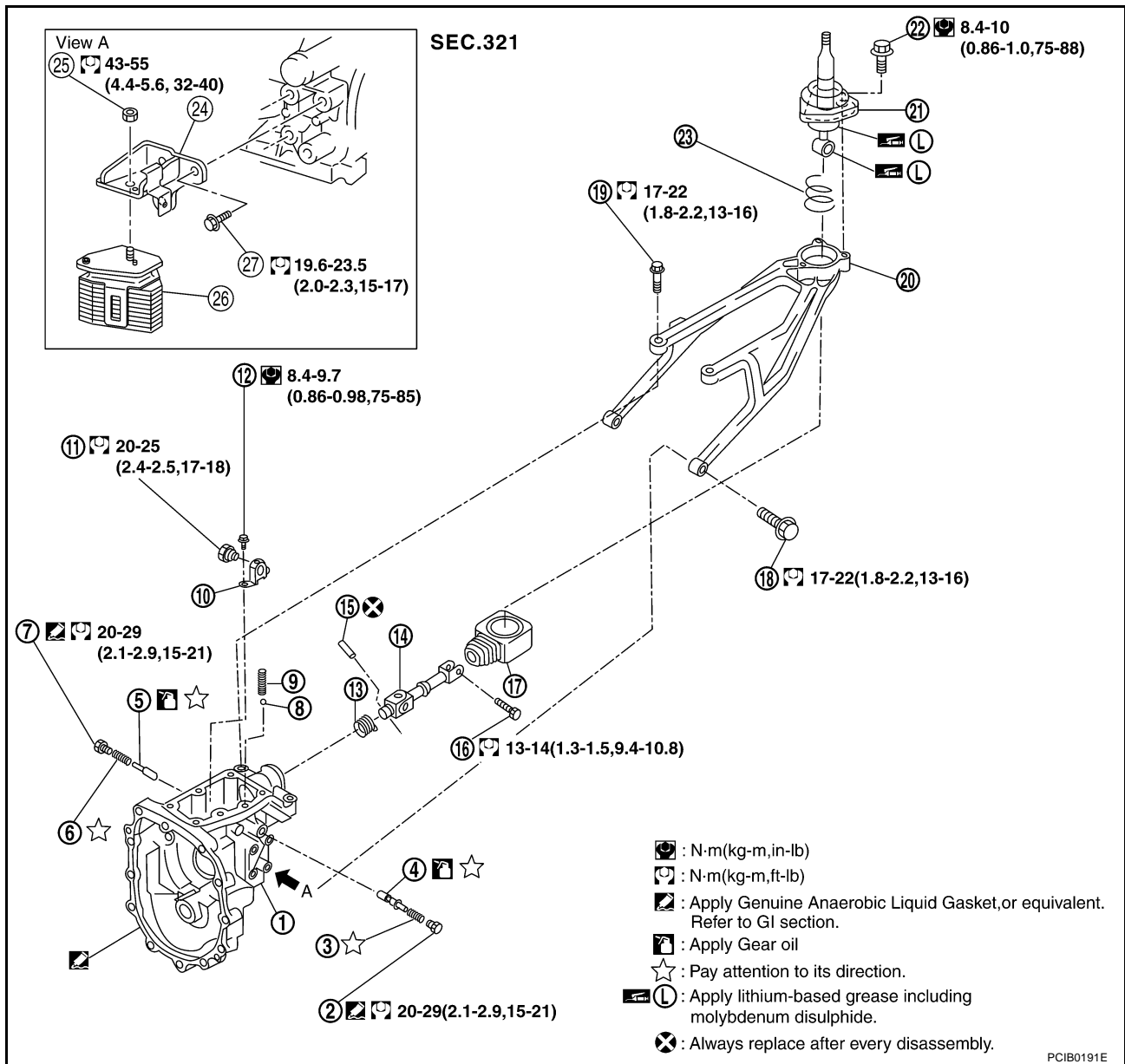

- | | | |
|--------------------------|---------------------------|----------------------------|
| 1. Rear extension case | 2. Return spring plug | 3. Return spring |
| 4. Return spring plunger | 5. Return spring plunger | 6. Return spring |
| 7. Return spring plug | 8. Check ball | 9. Check select spring |
| 10. Control bracket | 11. Check shift pin | 12. Bolt |
| 13. Boot | 14. Control rod | 15. Retaining pin |
| 16. Bolt | 17. Boot | 18. Bolt |
| 19. Bolt | 20. Control lever housing | 21. Control lever |
| 22. Bolt | 23. Control lever spring | 24. Dynamic damper bracket |
| 25. Nut | 26. Dynamic damper | 27. Bolt |

TRANSMISSION ASSEMBLY

Disassembly and Assembly DISASSEMBLY

ACS003TK

Case Components

1. Remove rear extension upper cover mounting bolts.
2. Remove rear extension upper cover and rear extension upper cover gasket.

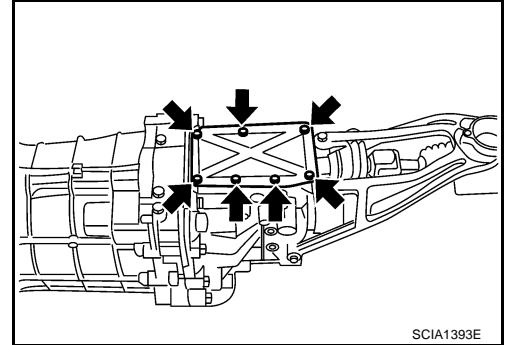

3. Remove check select spring and check ball from the rear extension case.

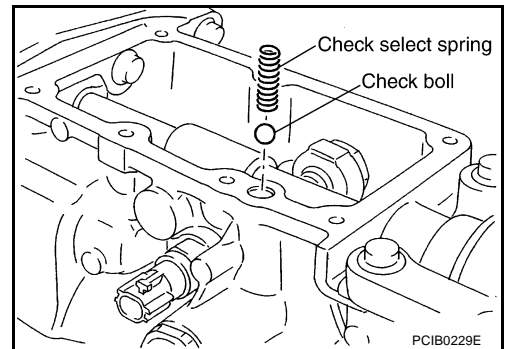

4. Using a pin punch [6 mm (0.24 in) dia.] to knock out retaining pin and then remove control rod.
5. Remove neutral position switch, plunger and reverse switch.

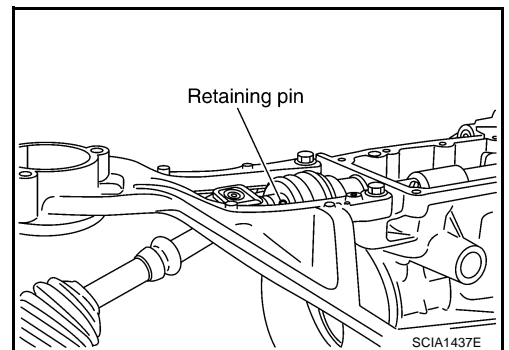

6. Remove control bracket mounting bolts. Then remove check shift pin and control bracket as one unit.

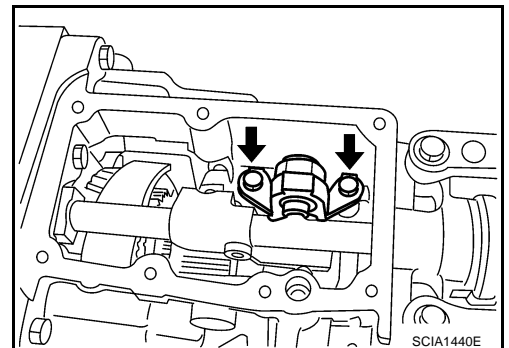

A
B
MT
D
E
F
G
H
I
J
K
L
M

TRANSMISSION ASSEMBLY

7. Remove right and left return spring plug. Then remove return spring and plunger from the rear extension.

CAUTION:

Return spring and plunger have different lengths for right and left sides. Identify right and left side and then store.

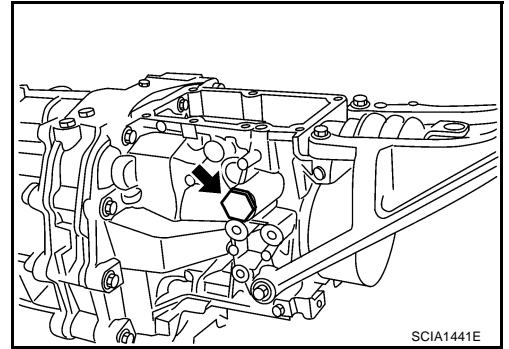

8. Using oil seal puller, remove rear oil seal.

Tool number : KV381054S0 (-)

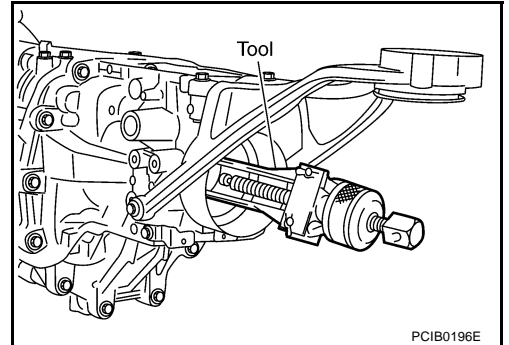

9. Remove rear extension case mounting bolt. Using a soft hammer, tap rear extension assembly to remove.
10. Remove control lever housing mounting bolts, and remove control lever housing. Refer to [MT-27, "SHIFT CONTROL COMPONENTS"](#) .
11. Remove control shaft oil seal. Refer to [MT-22, "CASE COMPONENTS"](#) .
12. Remove rear extension oil gutter. Refer to [MT-22, "CASE COMPONENTS"](#) .

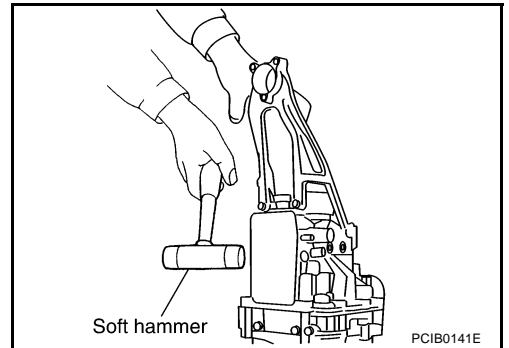

13. Remove reverse idler thrust washer, reverse idler gear, idler needle bearing from the idler shaft.
14. Remove reverse idler shaft.

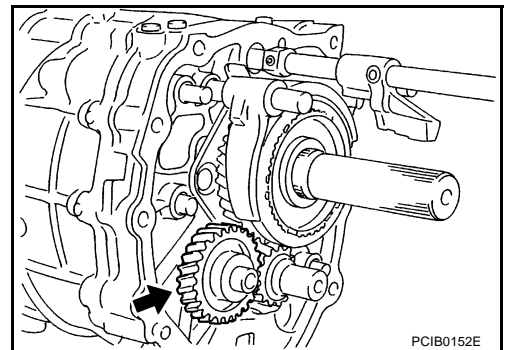

15. Remove withdrawal lever ball pin.
16. Remove front cover mounting bolt, then remove front cover and from cover gasket.

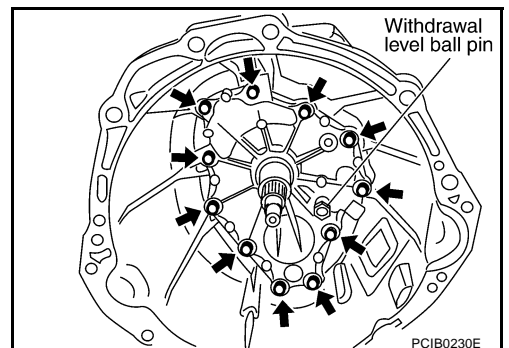

TRANSMISSION ASSEMBLY

17. Remove front cover oil seal, using a flat-bladed screwdriver,.

CAUTION:

Be careful not to damage front cover mating surface.

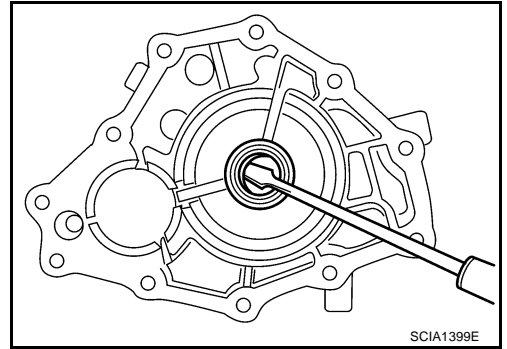

18. Remove nut shown in the figure.

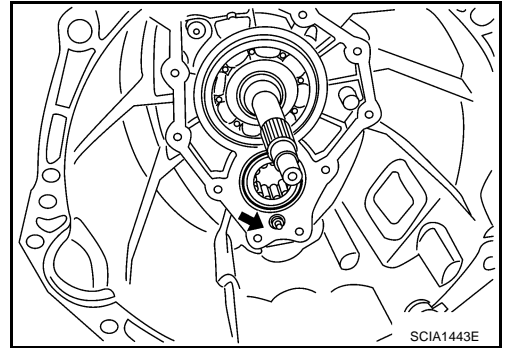

19. Remove snap ring of main drive gear bearing, using snap ring pliers,

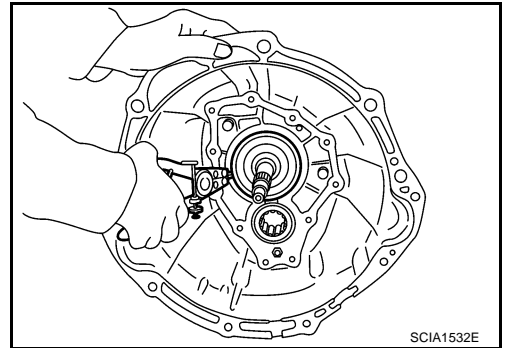

20. Using a soft hammer to carefully tap main shaft and counter shaft from the transmission case side, and then separate adapter plate and transmission case.

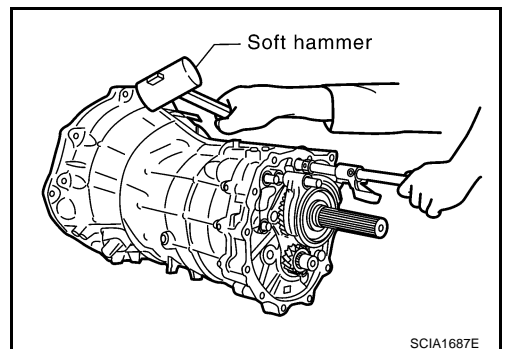

21. Remove counter front bearing.

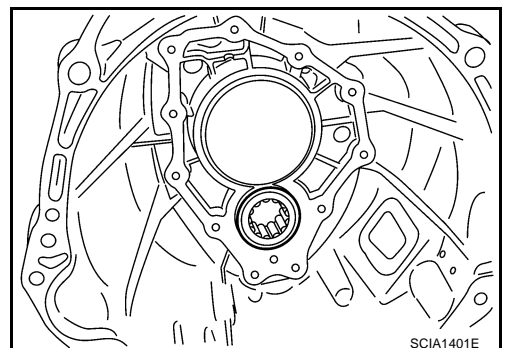

A
B
MT
D
E
F
G
H
I
J
K
L
M

TRANSMISSION ASSEMBLY

Shift Control Components

1. Using a vise, secure the adapter plate.

Tool number : ST224490000 (-)

CAUTION:

Do not directly secure the surface in a vise.

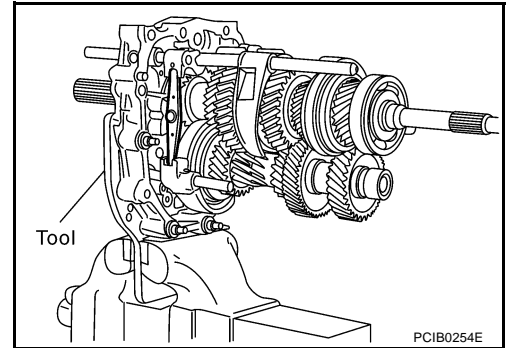

2. Remove baffle plate mounting bolts, and remove baffle plate.

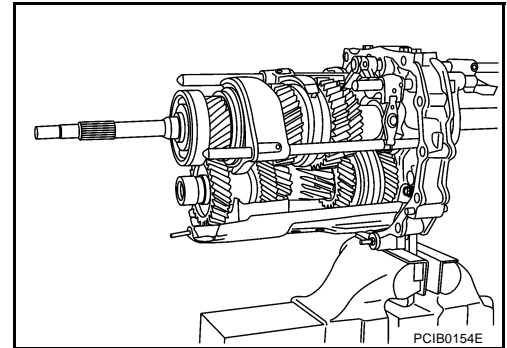

3. Knock out retaining pin, using a pin punch [6 mm (0.24 in) dia.]. Then remove striking rod and striking lever.

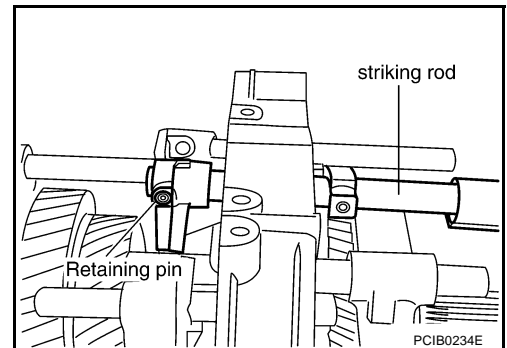

4. Remove check ball plug then remove check ball spring and check ball, from the adapter plate.

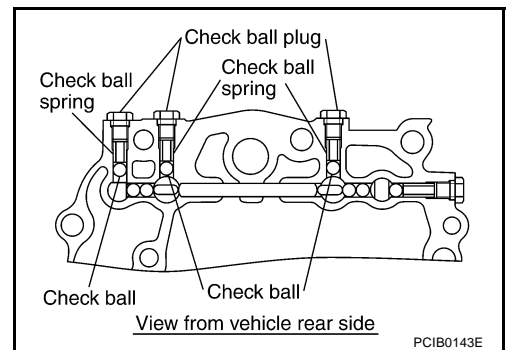

TRANSMISSION ASSEMBLY

5. Remove 3rd - 4th control lever mounting bolts then remove 3rd - 4th control lever and shifter cap assembly.

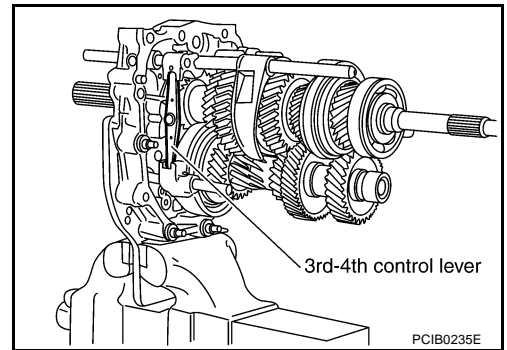

6. Remove check ball plug and then remove check ball spring and check ball, from the adapter plate.

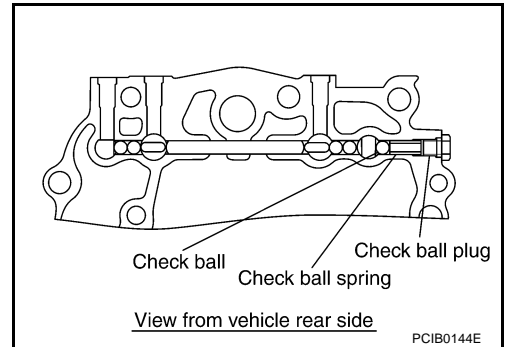

7. Using a pin punch [6 mm (0.24 in) dia.] to knock out retaining pin of 3rd - 4th fork rod bracket and then remove 3rd - 4th fork rod from the adapter plate.

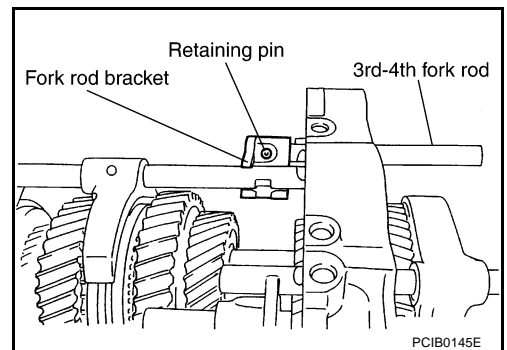

8. Using a pin punch [6 mm (0.24 in) dia.] to knock out retaining pin, and then remove 3rd - 4th fork rod (reversal side) and shift fork.

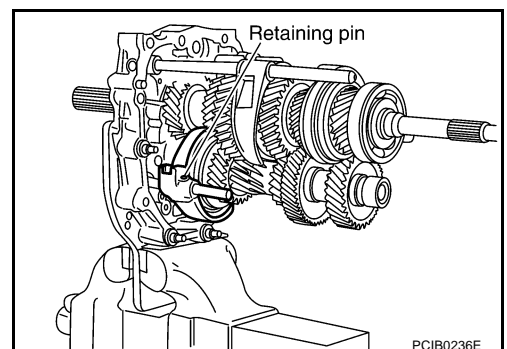

9. Remove check ball from the adapter plate.

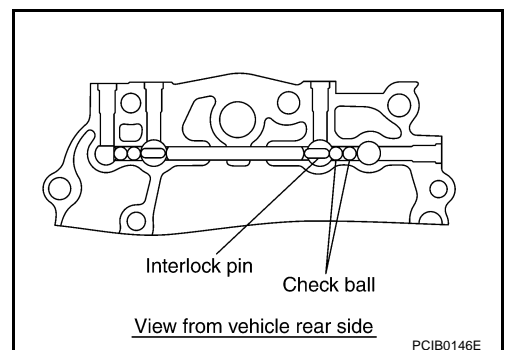

A
B
MT
D
E
F
G
H
I
J
K
L
M

TRANSMISSION ASSEMBLY

10. Using a pin punch [6 mm (0.24 in) dia.] to knock out retaining pin, and then remove 1st - 2nd fork rod and shift fork.

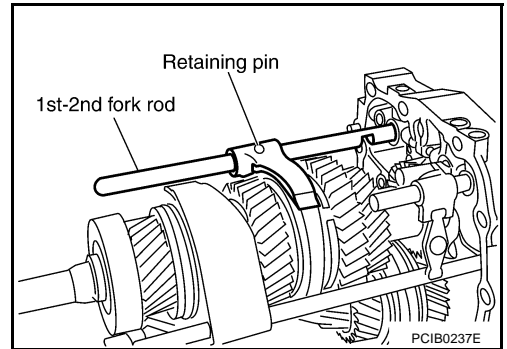

11. Remove interlock plunger and interlock pin.

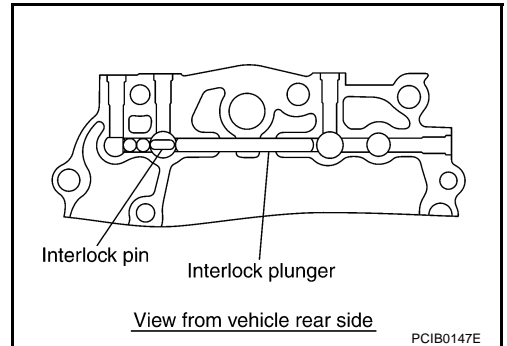

12. Using a pin punch [6 mm (0.24 in) dia.] to knock out retaining pin, and then remove reverse fork rod and shift fork.

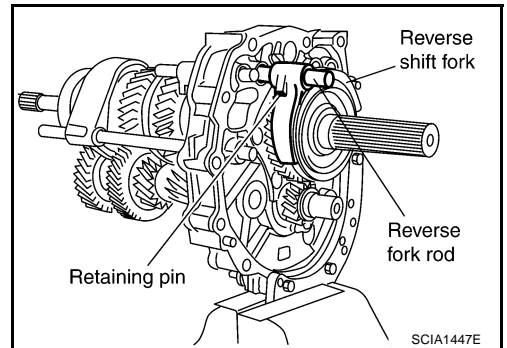

13. Remove check ball.

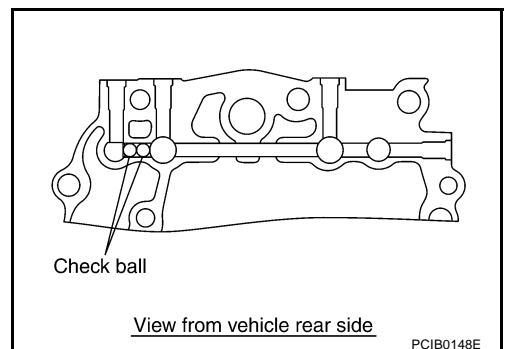

14. Remove 5th - 6th control lever mounting bolts and then remove 5th - 6th control lever assembly.

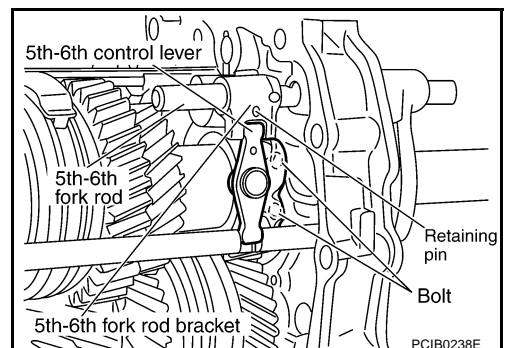

TRANSMISSION ASSEMBLY

15. Using a pin punch [6 mm (0.24 in) dia.] to knock out retaining pin of 5th - 6th fork rod bracket and then remove 5th - 6th fork rod.

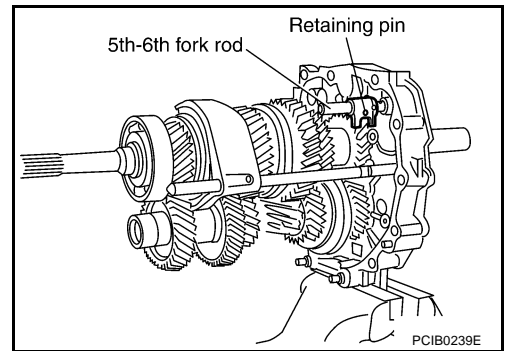

16. Using a pin punch [6 mm (0.24 in) dia.] to knock out retaining pin, and then remove 5th - 6th fork rod (reversal side) and shift fork.

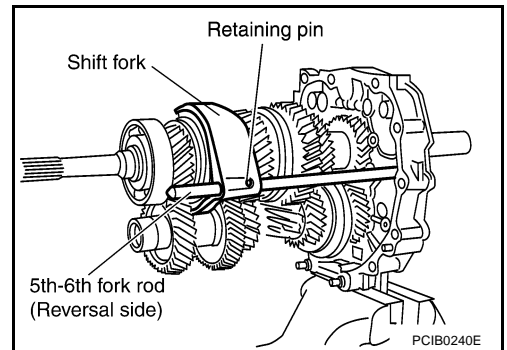

Gear Components

1. Before disassembly, measure end play for each position. If the end play or backlash is outside the standards, disassemble and inspect.

- Main drive gear.

End play : 0 - 0.10mm (0 - 0.004in)

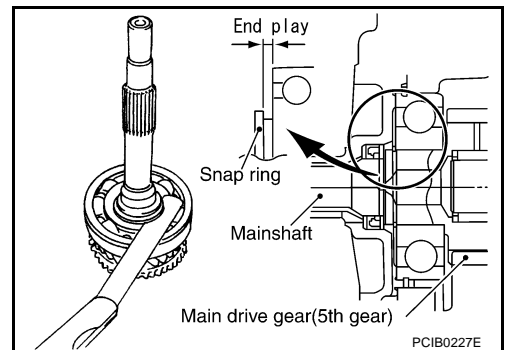

- Mainshaft front

End play : 0 - 0.10mm (0 - 0.004in)

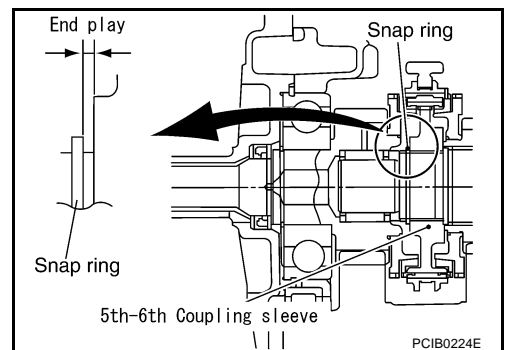

A
B
MT
D
E
F
G
H
I
J
K
L
M

TRANSMISSION ASSEMBLY

- Mainshaft rear

End play : 0 - 0.10mm (0 - 0.004in)

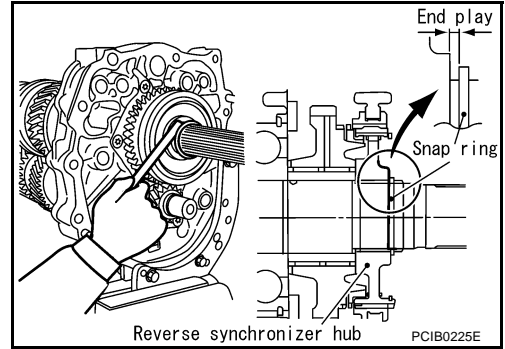

- Counter gear

End play : 0 - 0.10mm (0 - 0.004in)

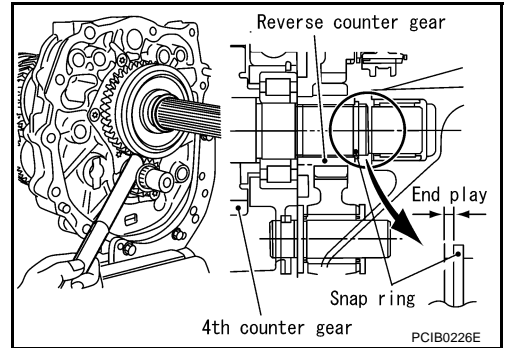

2. After removing snap ring and reverse coupling snap ring, using puller to remove reverse main gear and reverse synchronizer assembly.

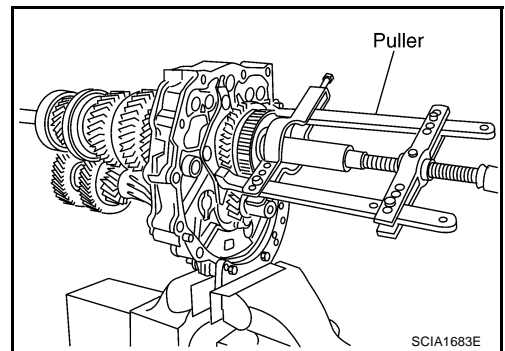

3. Remove bolts shown in the figure and then remove mainshaft bearing retainer plate.

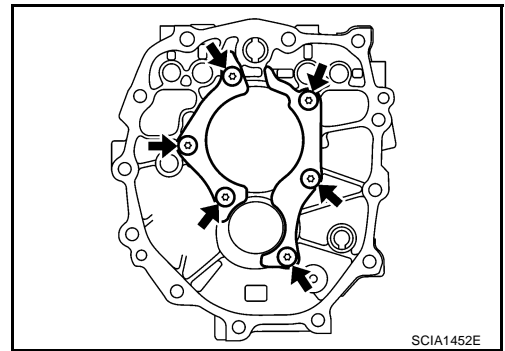

4. After removing snap ring, using the puller to remove reverse counter gear and counter rear bearing spacer.

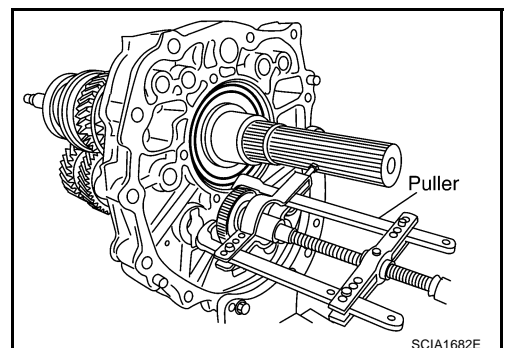

TRANSMISSION ASSEMBLY

5. Remove mainshaft bearing snap ring.

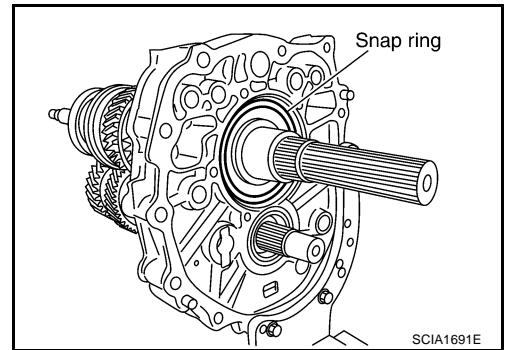

6. Carefully tap mainshaft with a plastic hammer and then remove mainshaft, main drive gear, and counter shaft from adapter plate.

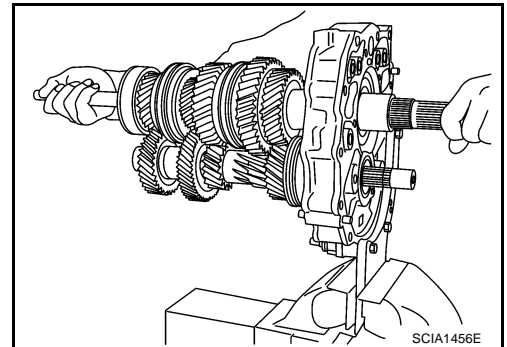

7. Remove counter rear bearing.

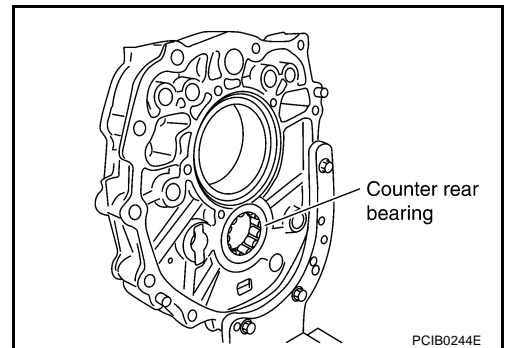

8. Remove snap ring from main drive gear, using snap ring pliers.

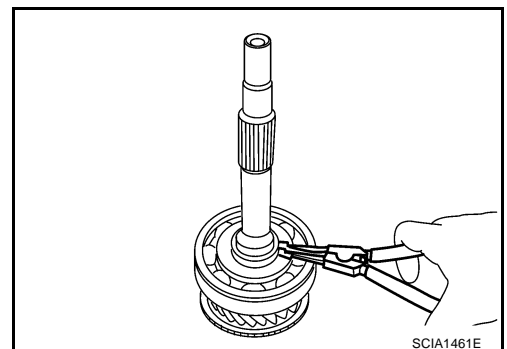

9. Set the suitable puller on the main drive gear and then using a press to remove main drive gear bearing from the main drive gear.

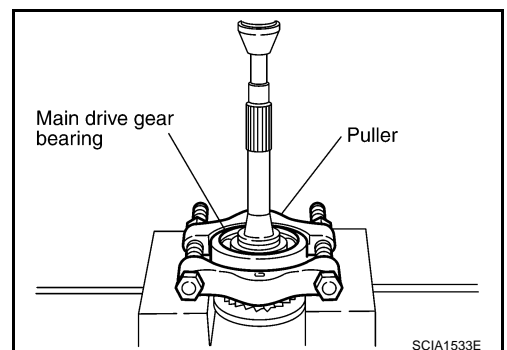

A
B
MT
D
E
F
G
H
I
J
K
L
M

TRANSMISSION ASSEMBLY

10. Using a press to remove the reverse main gear bushing, mainshaft bearing, and 4th main gear.

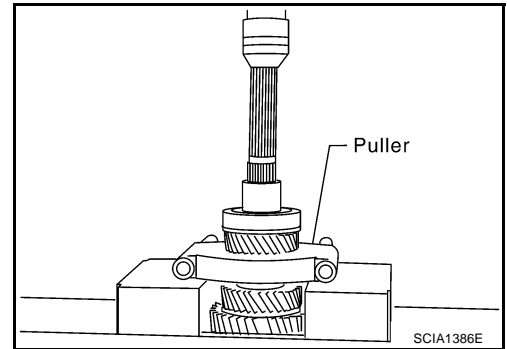

11. Remove 3rd - 4th main spacer.
12. Using a press to remove 1st main gear and 3rd main gear.

CAUTION:

Be careful not to damage the baulk ring.

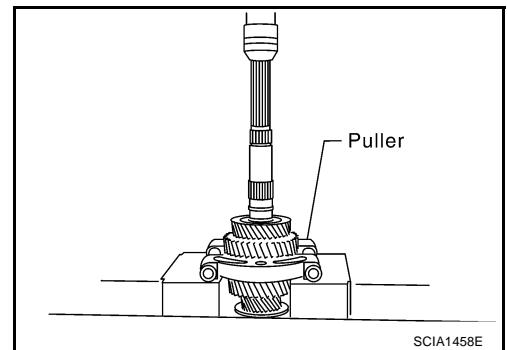

13. Using a press to remove 1st gear bushing, 1st - 2nd synchronizer assembly, and 2nd main gear.

CAUTION:

Be aware that when using the press, if the mainshaft gear positioner catches on the V-block, etc., the mainshaft could be damaged.

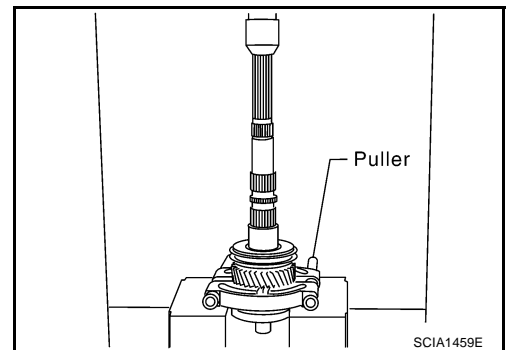

14. After removing snap ring, using a press to remove 6th main gear and 5th - 6th synchronizer assembly.

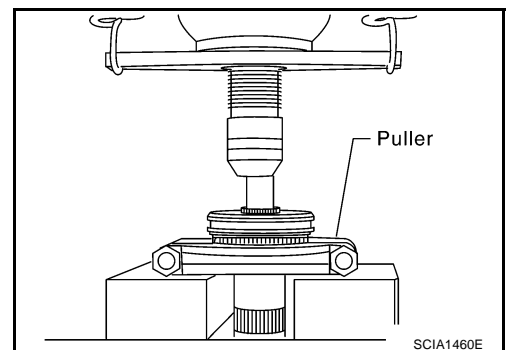

TRANSMISSION ASSEMBLY

15. Using a press to remove the 3rd counter gear, 3rd - 4th synchronizer assembly, 4th counter gear, 4th gear bushing, and counter rear bearing inner race.

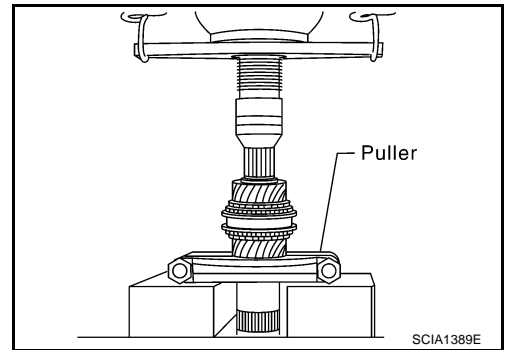

16. Using a press to remove the 3rd gear bushing.

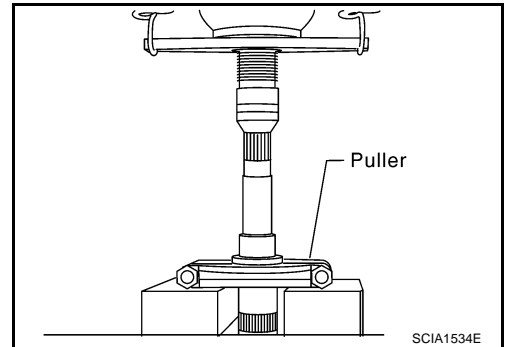

INSPECTION AFTER DISASSEMBLY

Shift Control

If the contact surface on striking lever, fork rod, fork, etc. has excessive wear, abrasion, bend, or any other damage, replace the components.

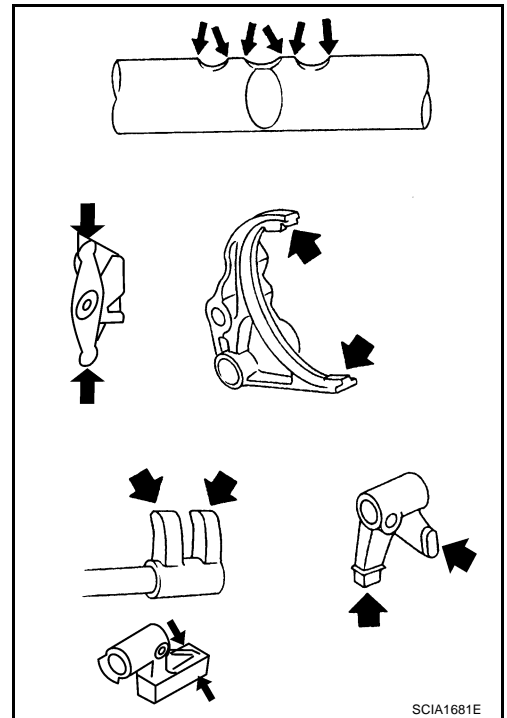

A
B
MT
D
E
F
G
H
I
J
K
L
M

TRANSMISSION ASSEMBLY

Gear and Shaft

If the contact surface on each gear, mainshaft, main drive gear, or counter gear, etc. has damage, peeling, abrasion, dent, bent, or any other damage, replace the components.

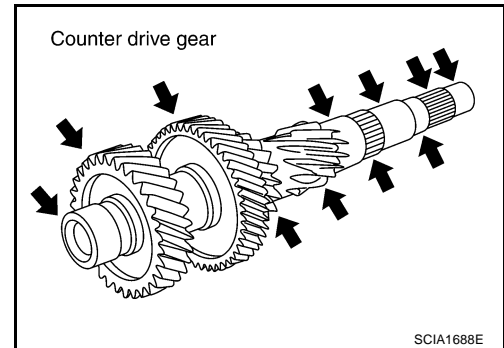
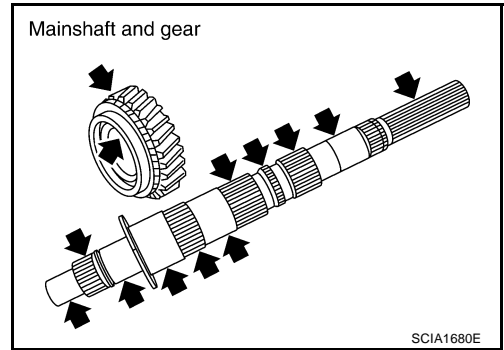

Synchronizer

- If the contact surface on coupling sleeve, synchronizer hub, and shifting insert has damage or abrasion, replace the components.
- Coupling sleeve and synchronizer hub shall move smoothly.

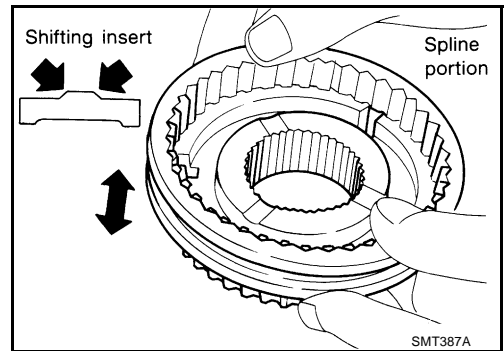

- If the cam surface on baulk ring or contact surface on insert has damage or excessive wear, replace with a new one.
- If insert spring is damaged, replace with a new one.

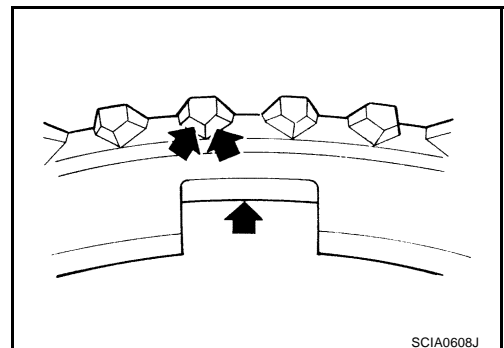

TRANSMISSION ASSEMBLY

Single Cone Synchronizer (Model code number. CD000: 3rd&4th&5th&6th, Model code number. CD005: 5th&6th)

- Push baulk ring on the cone and measure baulk ring back surface clearance at two locations or more on opposite sides, find the average value, and replace it if it is outside the limit value.

Clearance

Standard : 0.70 - 1.25 mm (0.028 - 0.049 in)

Limit value : 0.5 mm (0.020 in) or less

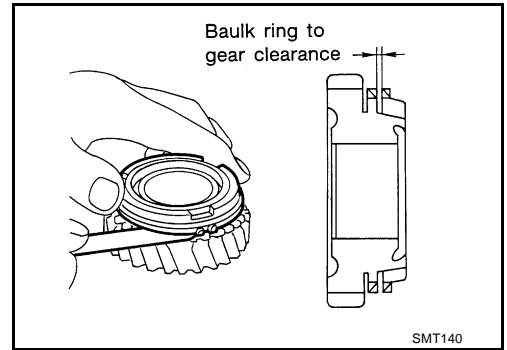

NOTE:

- 5th and 6th baulk rings have three spaces that two gear teeth are missing as shown in the figure.
- 5th and 6th baulk rings resemble reverse baulk ring in shape. Reverse baulk ring has a ditch for identification. (Refer to pages of baulk ring.)

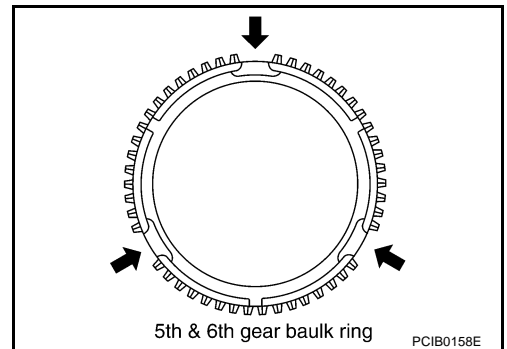

Double Cone Synchronizer (Model code number. CD000:1st&2nd, Model code number. CD005: 1st&3rd&4th)

Follow the instructions below and inspect the clearance of the 1st and 2nd gear outer baulk ring, synchronizer cone, inner baulk ring.

CAUTION:

Clearances "A" and "B" of the outer baulk ring, synchronizer cone, and inner baulk ring are controlled as a set, so if the clearance is outside the limit value, replace the synchronizer assembly.

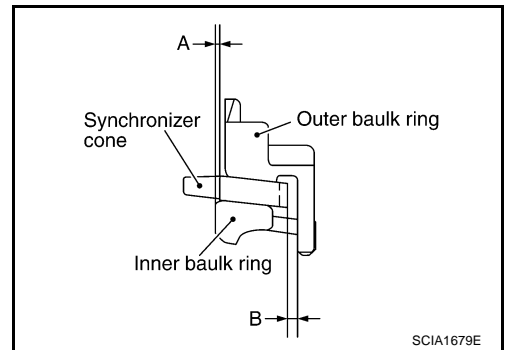

- Using a dial gauge, measure clearance A at 2 or more points diagonally opposite, and calculate mean value.

Clearance A

Standard : 0.5 - 0.7 mm (0.020 - 0.028 in)

Limit value : 0.3 mm (0.012 in) or less

Tool number : ST30031000 (J22912 - 01)

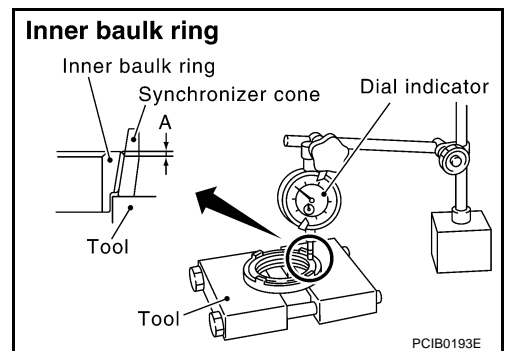

TRANSMISSION ASSEMBLY

- Using a feeler gauge, measure clearance B at 2 or more points diagonally opposite, and calculate mean value.

Clearance B

Standard 1st : 1.0 - 1.5 mm (0.039 - 0.059 in)

Standard 2nd (Model code number. CD005)
: 1.0 - 1.5 mm (0.039 - 0.059 in)

Standard 3rd, 4th (Model code number. CD000)
: 0.85 - 1.35 mm (0.033 - 0.053 in)

Limit value : 0.7 mm (0.028 in) or less

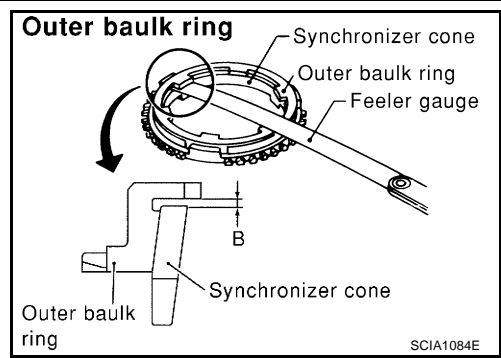

NOTE:

1st baulk ring has three spaces that one gear tooth is missing as shown in the figure.

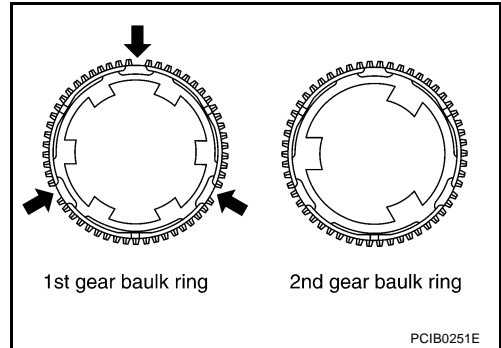

Triple cone synchronizer (Model code number. CD 005:2nd)

Check clearance for outer baulk ring, synchronizer cone and inner baulk ring of triple cone synchronizer following the direction.

NOTE:

Outer baulk ring, synchronizer cone and inner baulk ring, three control "clearance A, B and C" as a three - piece suite. If the value exceeds the limit value, replace them as a three - piece suite.

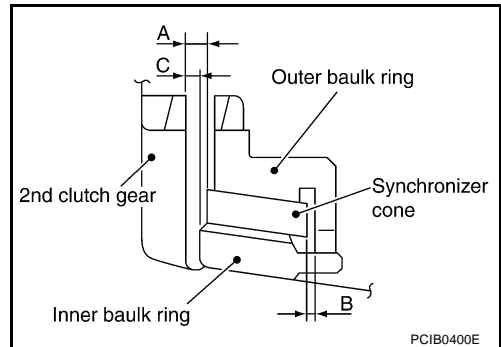

- Using feeler gauge put and press synchronizer on 2nd main gear taper cone. And then measure "clearance A" at more then 2 diagonal points, and calculate the average.

Clearance A

Reference value : 0.6 - 1.3 mm (0.054 - 0.051in)

Limit value : 0.3 mm (0.012 in) or less

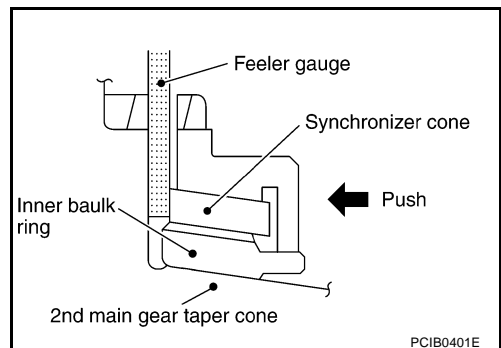

TRANSMISSION ASSEMBLY

2. Using feeler gauge measure "clearance B" at more than 2 diagonal positions, and calculate the average.

Clearance B

Reference value : 0.85 - 1.35 mm (0.033 - 0.053 in)

Limit value : 0.7 mm (0.028 in) or less

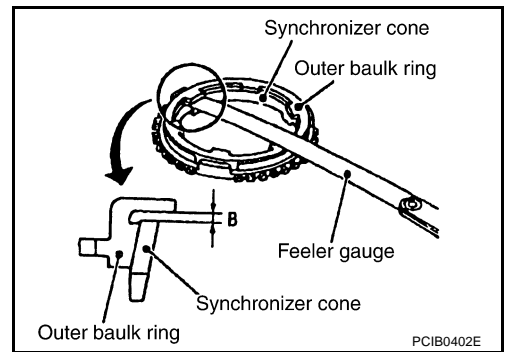

3. Using filler gauge put and press synchronizer on 2nd main gear taper cone. And then measure "clearance C" at more than 2 diagonal points, and calculate the average.

Clearance C

Reference value : 0.7 - 1.25 mm (0.028 - 0.049 in)

Limit value : 0.3 mm (0.012 in) or less

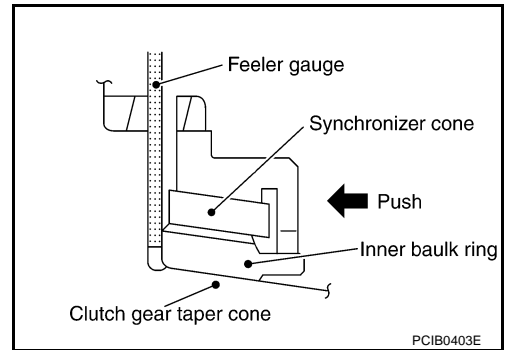

Reverse Synchronizer Assembly

Push baulk on the cone and measure baulk ring back surface clearance at two locations or more on opposite sides, find the average value, and replace if it is outside the limit value.

Clearance

Standard : 0.75 - 1.2 mm (0.030 - 0.047 in)

Limit value : 0.5 mm (0.020 in) or less

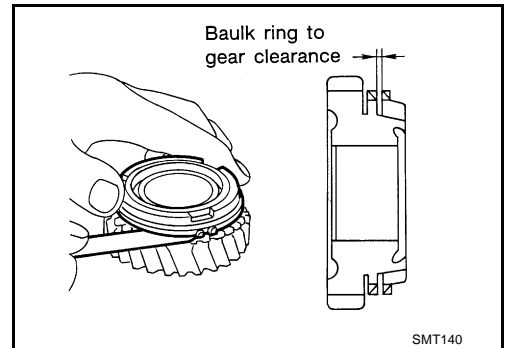

NOTE:

Reverse baulk ring has three spaces that two gear teeth are missing, and each space has small ditch for identification as shown in the figure.

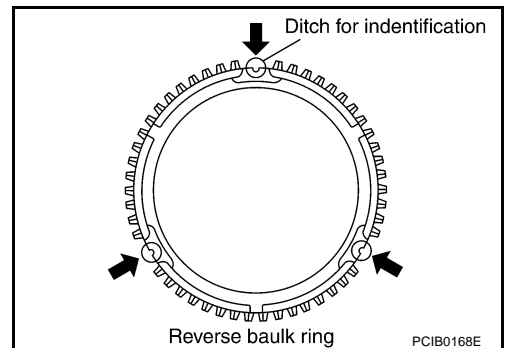

A
B
MT
D
E
F
G
H
I
J
K
L
M

TRANSMISSION ASSEMBLY

Bearing

If the bearing does not rotate smoothly or the contact surface on ball or race is damaged or peeled, replace with new ones.

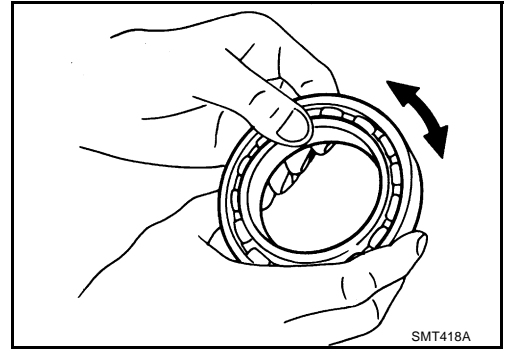

ASSEMBLY

Gear Components

1. Install coupling sleeve and shifting insert in the 5th-6th synchronizer hub.

CAUTION:

Install coupling sleeve with the larger chamfer on the rear side.

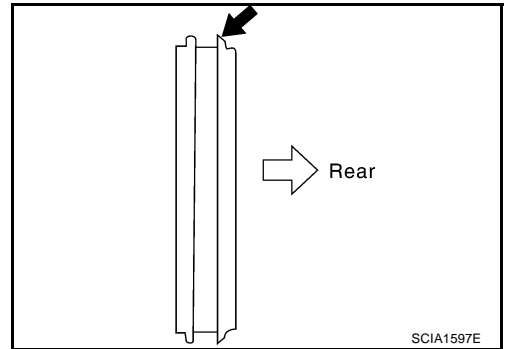

2. Install spread spring in the shifting insert.

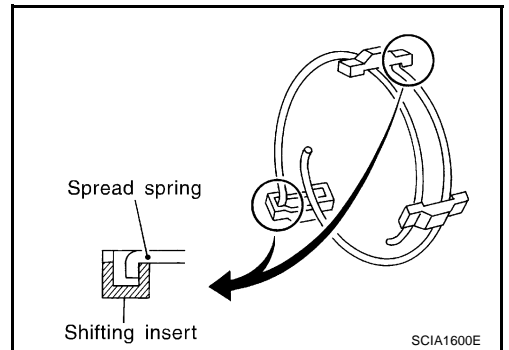

- Be careful with the shape of insert key to avoid misassembly.

CAUTION:

Do not install spread spring hook onto the same shifting insert.

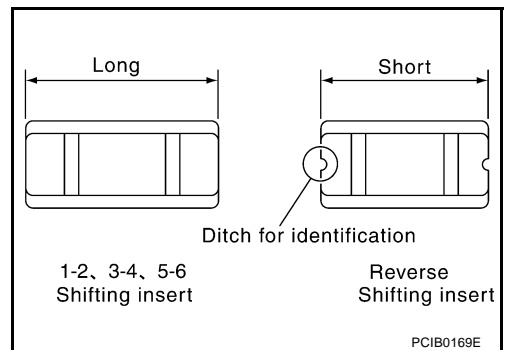

TRANSMISSION ASSEMBLY

3. After installing the needle bearing and 6th main gear on the mainshaft, using an inserter and a press to press fit the 5th - 6th synchronizer assembly.

Tool number : ST30911000 (—)

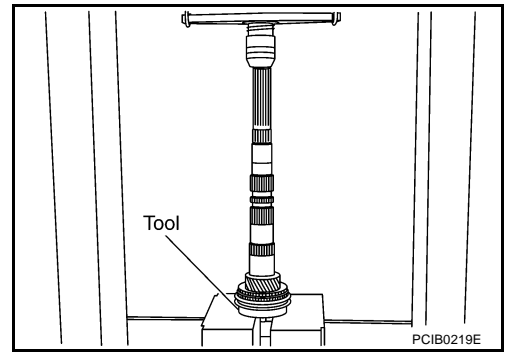

CAUTION:

- The synchronizer hub is not reusable. Never reuse it.
- When press fitting, install with the side having the three boss edge oil grooves facing the rear side.

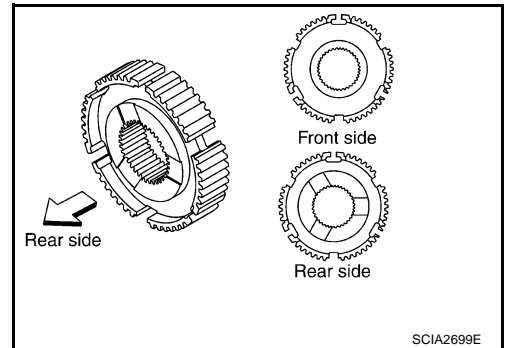

4. Select and install a snap ring so that the end play comes within the standard value.

End play : 0 - 0.10 mm (0 - 0.004 in)

CAUTION:

Snap rings are not reusable. Never reuse them.

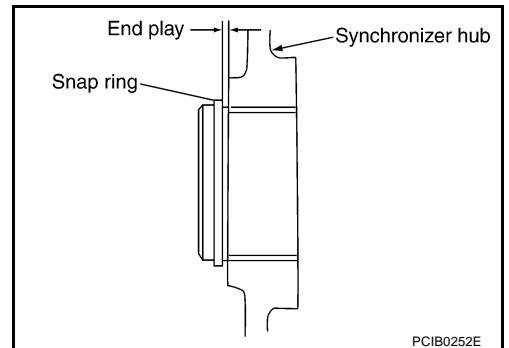

Mainshaft Snap Ring (Front Side)

Thickness	Part No.
2.08 mm (0.0819 in)	32204 CD000
2.14 mm (0.0843 in)	32204 CD001
2.20 mm (0.0866 in)	32204 CD002
2.26 mm (0.0890 in)	32204 CD003

5. Install coupling sleeve and shifting insert into the 1st - 2nd synchronizer hub.

CAUTION:

Install coupling sleeve with the identification groove side facing the rear side.

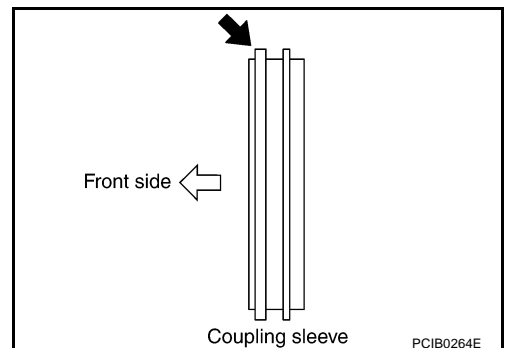

A
B
MT
D
E
F
G
H
I
J
K
L
M

TRANSMISSION ASSEMBLY

6. Install spread spring in the shifting insert.

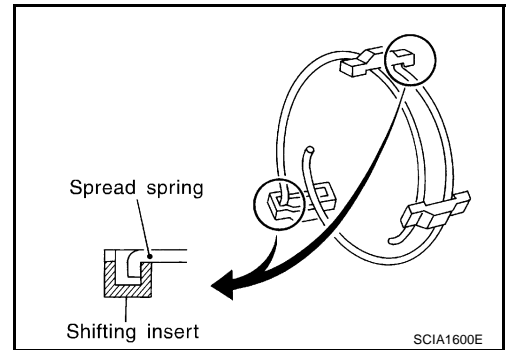

- Be careful with the shape of insert key to avoid misassembly.

CAUTION:

Do not install spread spring hook onto the same shifting insert.

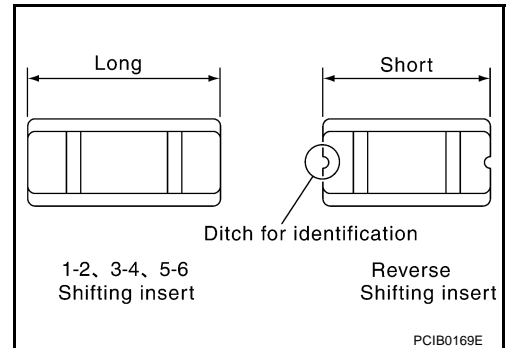

7. Install needle bearing and 2nd main gear on the mainshaft and then using a support ring and a press to press fit the 1st - 2nd synchronizer assembly.

Tool number : ST27861000 (—)

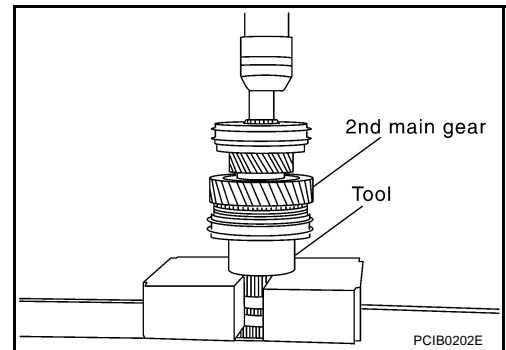

CAUTION:

- The synchronizer hub is not reusable. Never reuse it.
- When press fitting, install with the side having the three boss edge oil grooves facing the front side.

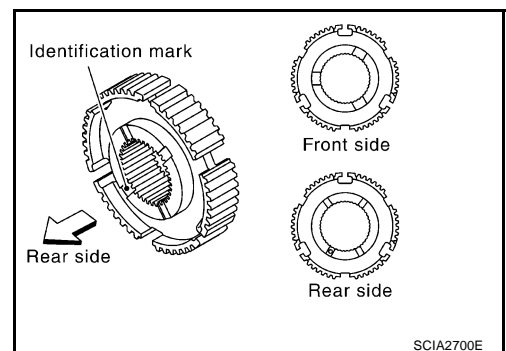

TRANSMISSION ASSEMBLY

8. Using a support ring and a press to press fit the 1st gear bushing.

Tool number : ST27861000 (—)

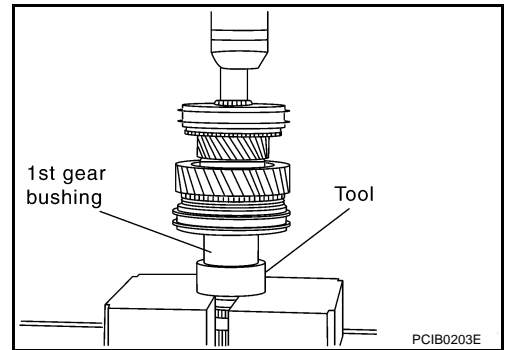

9. Install needle bearing and 1st main gear on the mainshaft and then using the inserter and a press to press fit the 3rd main gear.

Tool number : ST30022000 (—)

CAUTION:
3rd main gear is not reusable. Never reuse it.

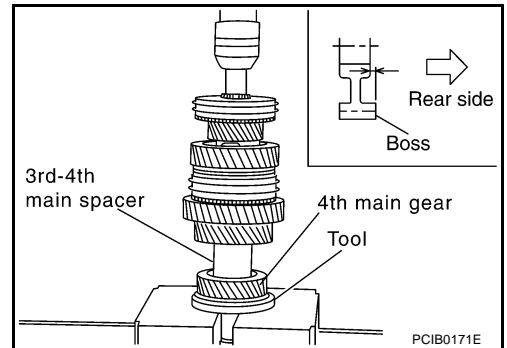

10. Install 3rd - 4th main spacer on the mainshaft and then using the inserter and a press to press fit the 4th main gear.

Tool number : ST30022000 (—)

CAUTION:
● 4th main gear is not reusable. Never reuse it.
● When installing, set boss to rear side.

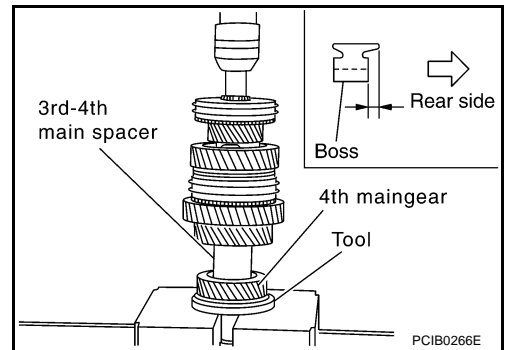

11. Using the inserter and a press to press fit the mainshaft bearing onto the mainshaft.

Tool number : ST30911000 (—)

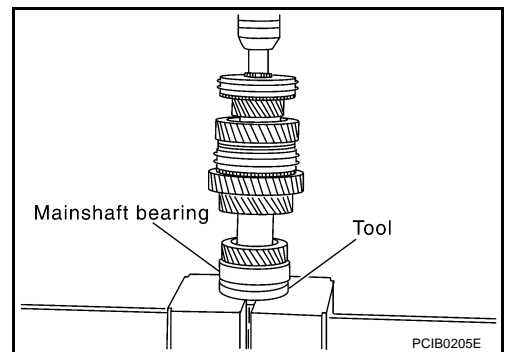

12. Using the inserter and a press to press fit the reverse main gear bushing onto the mainshaft.

Tool number : ST30911000 (—)

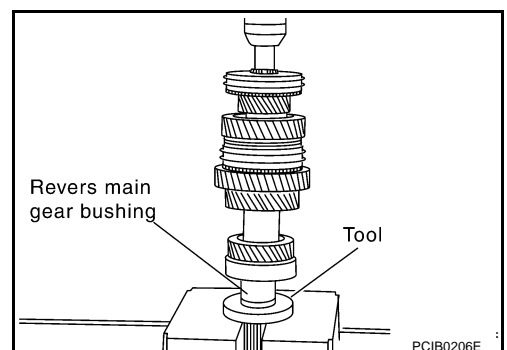

A
B
MT
D
E
F
G
H
I
J
K
L
M

TRANSMISSION ASSEMBLY

13. Using the inserter to press fit the 3rd gear bushing onto the countershaft.

Tool number : ST30911000 (—)

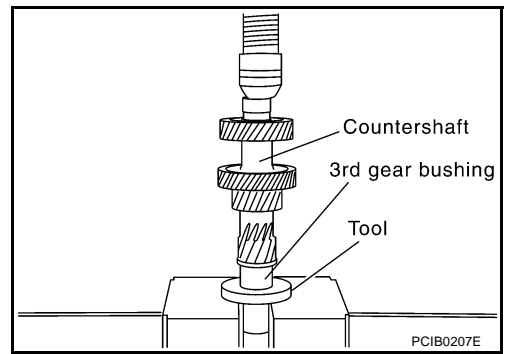

14. Install coupling sleeve and shifting insert into the 3rd - 4th synchronizer hub.

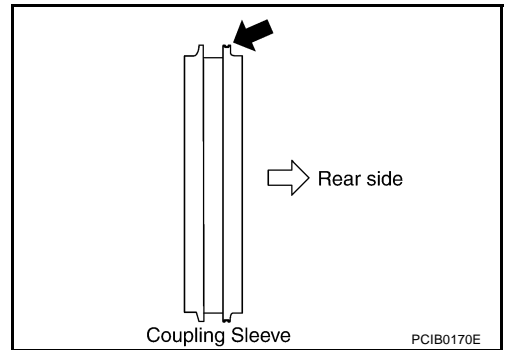

15. Install spread spring in the shifting insert.
Install coupling sleeve with the identification groove side facing the rear side.

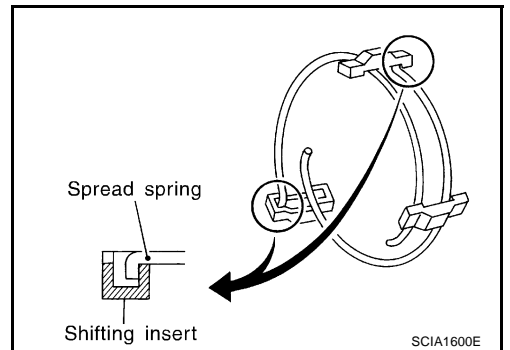

- Be careful with the shape of insert key to avoid misassembly.
CAUTION:
Do not install spread spring hook onto the same shifting insert.

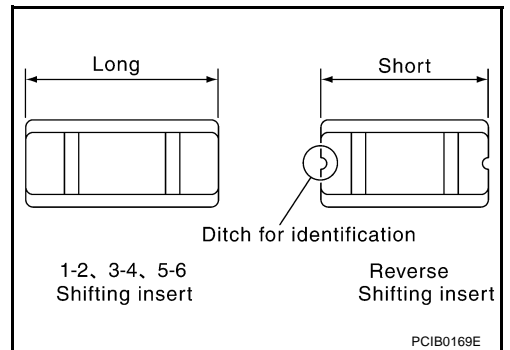

TRANSMISSION ASSEMBLY

16. Install the 3rd - 4th synchronizer assembly with the following procedure.
 - a. Install 3rd needle bearing and 3rd counter gear on the countershaft.
 - b. · Install 3rd baulk ring on the countershaft. (Model code number.CD000)
· Install 3rd inner baulk ring, 3rd synchronizer cone, 3rd outer baulk ring on the countershaft. (Model code number.CD005)
 - c. Using the inserter and a press to press fit the 3rd - 4th synchronizer assembly.

Tool number : ST30911000 (—)

CAUTION:

The synchronizer hub is not reusable. Never reuse it.

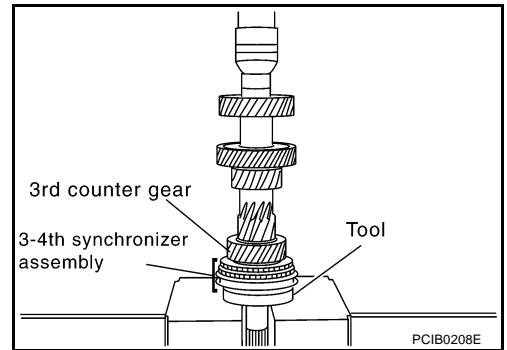

17. Install the 4th counter gear thrust washer with the following procedure.
 - a. · Install 4th baulk ring on the countershaft. (Model code number.CD000)
· Install 4th inner baulk ring, 4th synchronizer cone, 4th outer baulk ring on the countershaft. (Model code number.CD005)
 - b. Install 4th gear bushing and 4th needle bearing on the countershaft.
 - c. Using the inserter and a press to press fit the 4th counter gear thrust washer.

Tool number : KV40100630 (J26029)

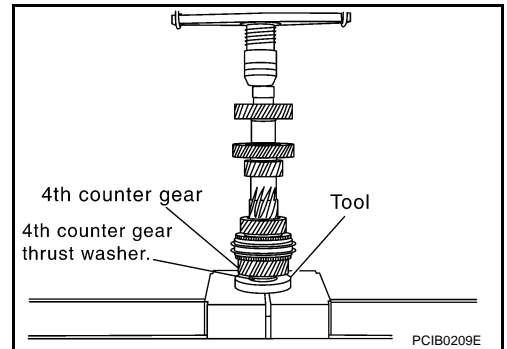

18. Using the drift and a press to press fit the counter rear bearing inner race onto the counter shaft.

Tool number : ST30032000 (J26010-1)

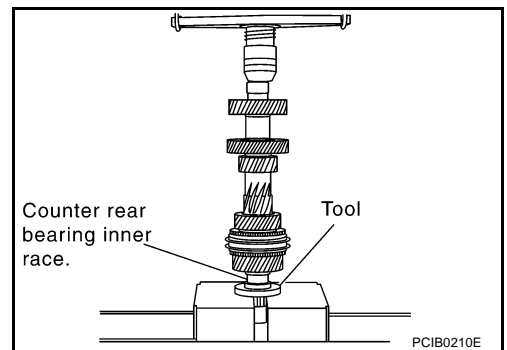

19. Using the drift and a press to press fit the main drive gear bearing onto the main drive gear.

Tool number : KV32102700 (—)

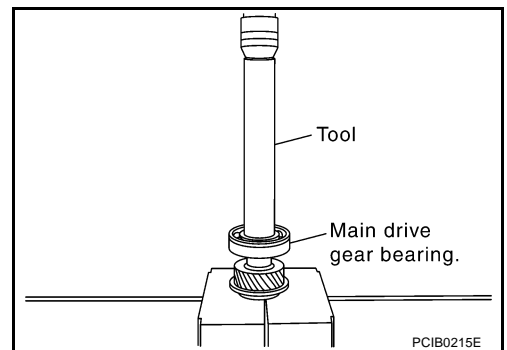

A
B
MT
D
E
F
G
H
I
J
K
L
M

TRANSMISSION ASSEMBLY

20. Select and install a snap ring to the main drive gear so that the end play comes within the standard value. Refer to [MT-62](#), "[Snap Rings](#)".

End play : 0 - 0.10 mm (0 - 0.004 in)

CAUTION:
Snap rings are not reusable. Never reuse them.

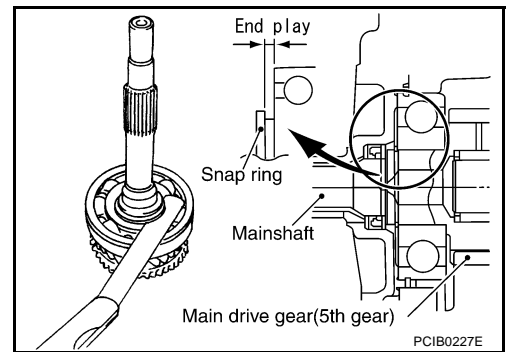

21. Install counter rear bearing onto the adapter plate, install the main driver gear, mainshaft, and counter gear as one unit, and then install the snap ring on the mainshaft bearing.

CAUTION:
Snap rings are not reusable. Never reuse them.

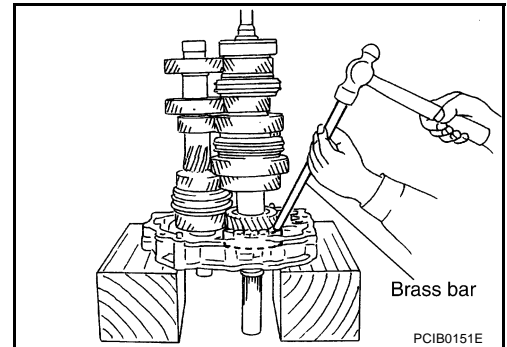

22. Install counter rear bearing onto the adapter plate using soft hammer or the equivalent.

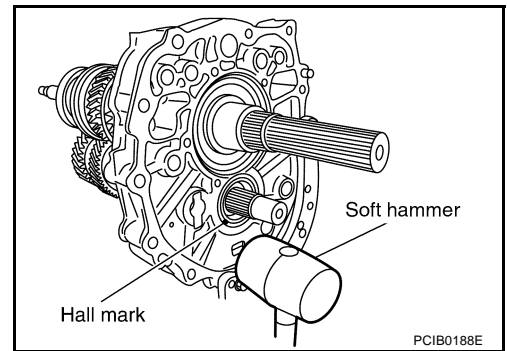

23. Apply genuine medium strength locking sealant or equivalent refer to GI section to the end of the bolt (first 3 to 4 threads), screw the bolt into the mainshaft bearing retainer plate, and tighten it to the specified torque.

 : 19 - 24 N·m (2.0 - 2.4 kg·m, 14 - 17 ft·lb)

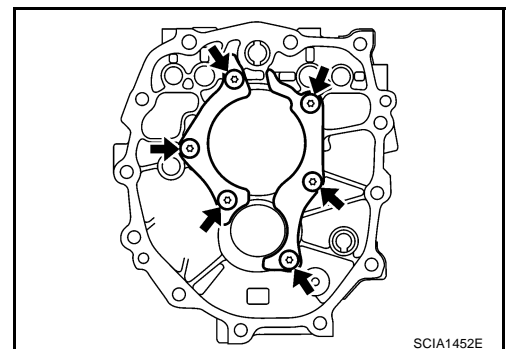

24. Install coupling sleeve and shifting insert into the reverse synchronizer hub.

CAUTION:
Install coupling sleeve with the larger chamfer on the rear side.

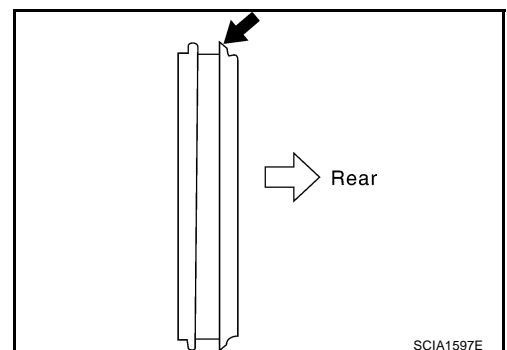

TRANSMISSION ASSEMBLY

25. Install spread spring in the shifting insert.

CAUTION:

Do not install spread spring hook onto the same shifting insert.

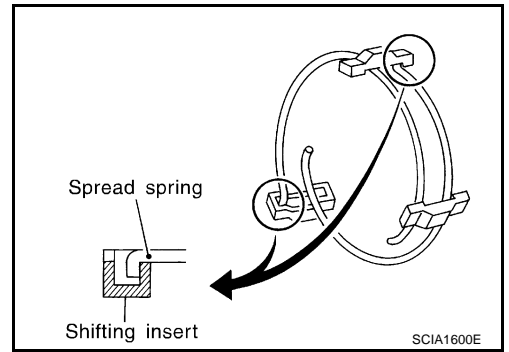

26. After installing the reverse main gear bushing and needle bearing and reverse main gear onto the mainshaft, using the drift and install the reverse synchronizer assembly.

Tool number (A) : KV32103300 (J46529)

Tool number (B) : ST01530000 (—)

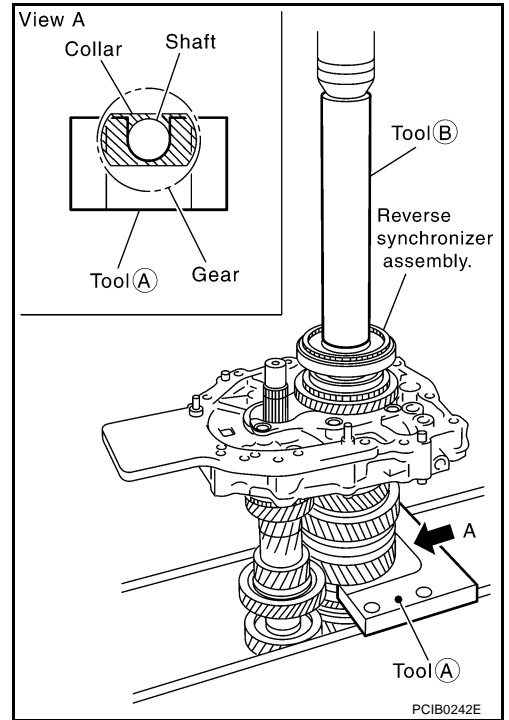

CAUTION:

- The synchronizer hub is not reusable. Never reuse it.
- When installing the synchronizer assembly, the shifting insert may fall out of the synchronizer hub, so have an assistant hold together the synchronizer assembly while conducting the work.
- When installing, face the side with three ditches to the front side.

27. Install reverse coupling snap ring.

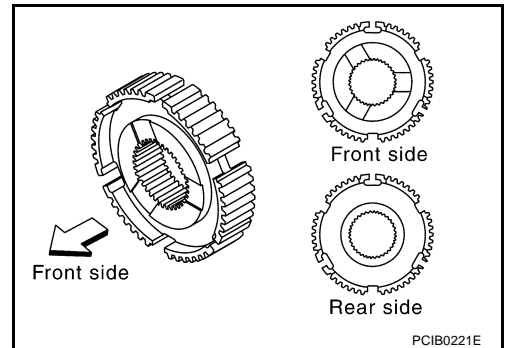

A
B
MT
D
E
F
G
H
I
J
K
L
M

TRANSMISSION ASSEMBLY

28. Select and install a snap ring so that the end play comes within the standard value.

End play : 0 - 0.10 mm (0 - 0.004 in)

CAUTION:
Snap rings are not reusable. Never reuse them.

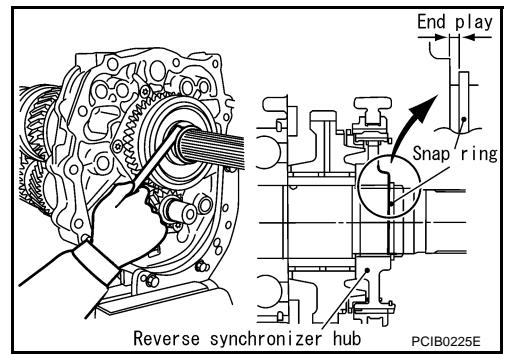

Mainshaft Snap Ring (Shaft rear end)

Thickness	Part No.
2.08 mm (0.0819 in)	32204 CD000
2.14 mm (0.0843 in)	32204 CD001
2.20 mm (0.0866 in)	32204 CD002
2.26 mm (0.0890 in)	32204 CD003
2.32 mm (0.0913 in)	32204 CD004
2.38 mm (0.0937 in)	32204 CD005
2.44 mm (0.0961 in)	32204 CD006
2.50 mm (0.0984 in)	32204 CD007
2.56 mm (0.1008 in)	32204 CD008
2.62 mm (0.1031 in)	32204 CD009
2.68 mm (0.1055 in)	32204 CD010
2.74 mm (0.1079 in)	32204 CD011
2.80 mm (0.1102 in)	32204 CD012
2.86 mm (0.1126 in)	32204 CD013
2.92 mm (0.1150 in)	32204 CD014
2.98 mm (0.1173 in)	32204 CD015

29. After installing counter rear spacer, press and fit reverse counter gear onto counter shaft with drift and press.

Tool number : ST23860000 (—)

CAUTION:
Reverse counter gear is not reusable. Never reuse it.
When installing counter bearing spacer, maker's stamp should face to the rear

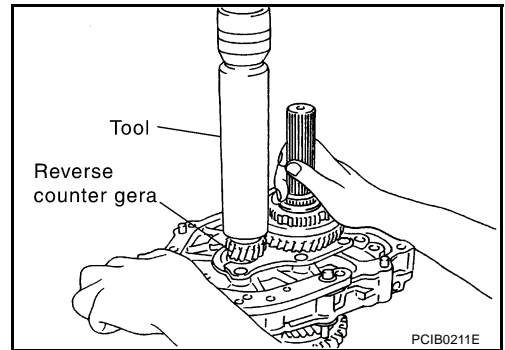

30. Select and install a snap ring so that the end play comes within the standard value.

End play : 0 - 0.10 mm (0 - 0.004 in)

CAUTION:
Snap rings are not reusable. Never reuse them.

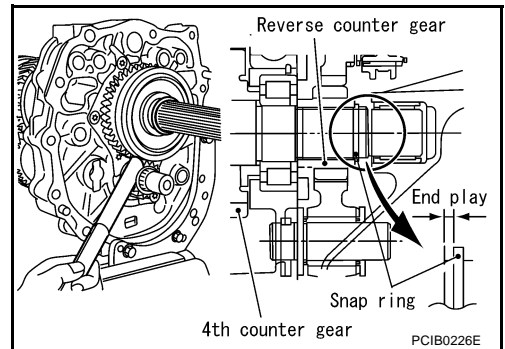

TRANSMISSION ASSEMBLY

Counter Gear

Thickness	Part No.
1.96 mm (0.0772 in)	32236 CD000
2.02 mm (0.0795 in)	32236 CD001
2.08 mm (0.0819 in)	32236 CD002
2.14 mm (0.0843 in)	32236 CD003
2.20 mm (0.0866 in)	32236 CD004
2.26 mm (0.0890 in)	32236 CD005
2.32 mm (0.0913 in)	32236 CD006
2.38 mm (0.0937 in)	32236 CD007
2.44 mm (0.0961 in)	32236 CD008
2.50 mm (0.0984 in)	32236 CD009
2.56 mm (0.1008 in)	32236 CD010
2.62 mm (0.1031 in)	32236 CD011

Shift Control Components

1. Install 5th-6th shift fork to 5th-6th coupling sleeve.
2. Install 5th-6th fork rod (reversal side) to 5th-6th shift fork.
3. Using a pin punch [6 mm (0.24i n) dia.] to tap the retaining pin into the 5th - 6th shift fork.

CAUTION:

Retaining pins are not reusable. Never reuse them.

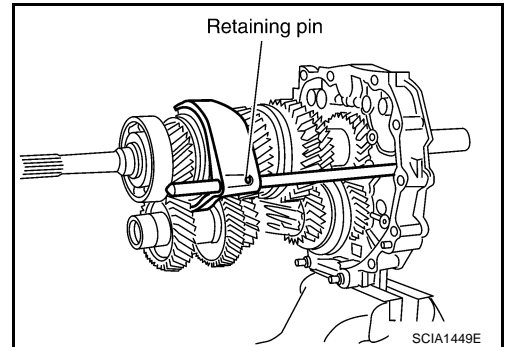

4. Install 5th-6th fork rod to adapter plate.
5. Install 5th-6th fork rod bracket to 5th-6th fork rod.
6. Using a pin punch [6 mm (0.24i n) dia.] to tap the retaining pin into the 5th - 6th fork rod bracket.

CAUTION:

Retaining pins are not reusable. Never reuse them.

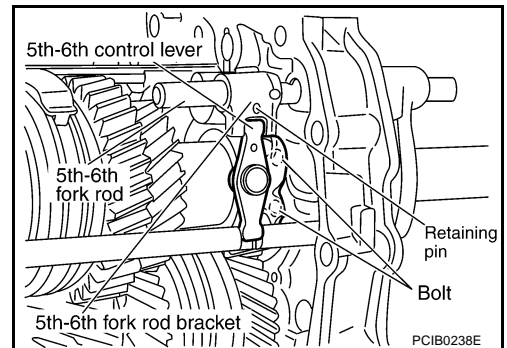

7. Install 5th - 6th control lever assembly.

 : 20 - 23 N·m (2.1 - 2.3 kg-m, 15 - 16 ft-lb)

CAUTION:

Set the projection upward.

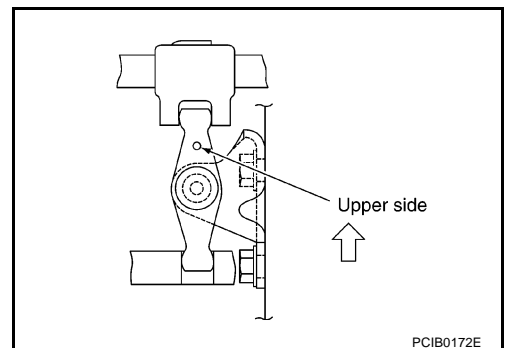

A
B
MT
D
E
F
G
H
I
J
K
L
M

TRANSMISSION ASSEMBLY

8. Install check ball to adapter plate.

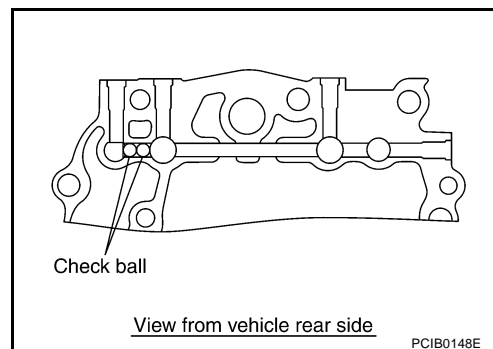

9. Install reverse shift fork to reverse coupling sleeve.
10. Install reverse fork rod to reverse shift fork.
11. Using a pin punch [6 mm (0.24 in) dia.] to tap the retaining pin into the reverse shift fork.

CAUTION:

Retaining pins are not reusable. Never reuse them.

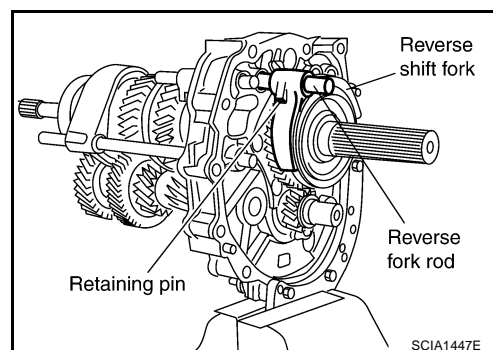

12. Install interlock pin and interlock plunger.

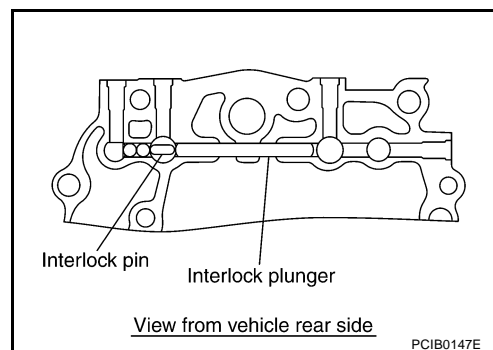

13. Install 1st-2nd shift fork to 1st-2nd coupling sleeve.
14. Install 1st-2nd fork rod to 1st-2nd shift fork.
15. Using a pin punch [6 mm (0.24 in) dia.] to tap the retaining pin into the 1st - 2nd shift fork.

CAUTION:

Retaining pins are not reusable. Never reuse them.

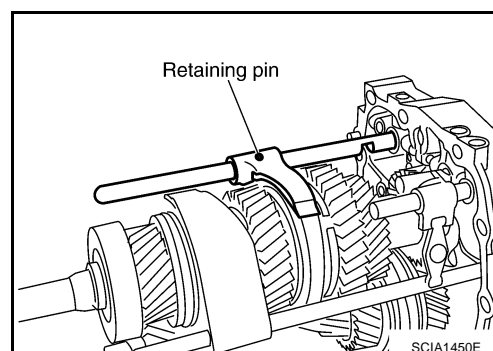

16. Install 3rd-4th shift fork to 3rd-4th coupling sleeve.
17. Install 3rd-4th fork rod (reversal side) to 3rd-4th shift fork.
18. Using a pin punch [6 mm (0.24 in) dia.] to tap the retaining pin into the 3rd - 4th shift fork (reversal side).

CAUTION:

Retaining pins are not reusable. Never reuse them.

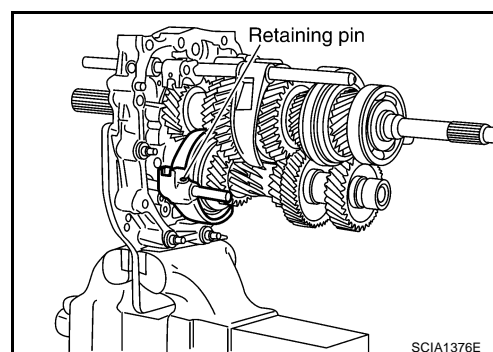

TRANSMISSION ASSEMBLY

19. Install interlock pin and check ball.

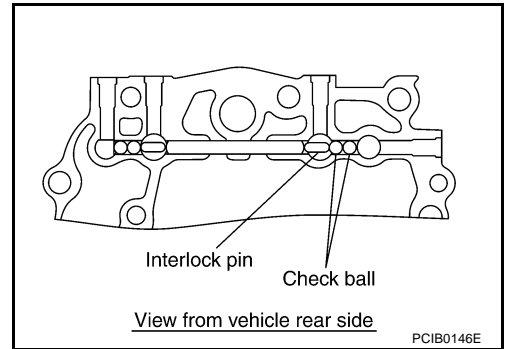

20. Install 3rd-4th fork rod to adapter plate.

21. Install 3rd-4th fork rod bracket to 3rd-4th fork rod.

22. Using a pin punch [6 mm (0.24 in) dia.] to tap the retaining pin into the 3rd - 4th fork rod bracket.

CAUTION:

Retaining pins are not reusable. Never reuse them.

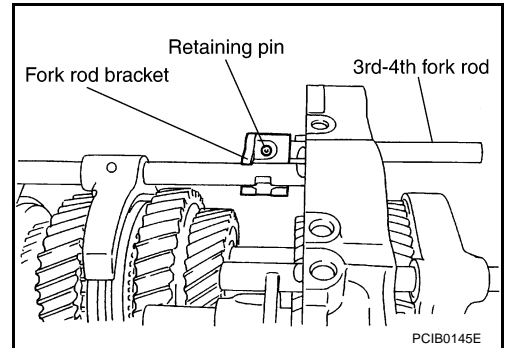

23. Install check ball, check ball spring and check ball plug.

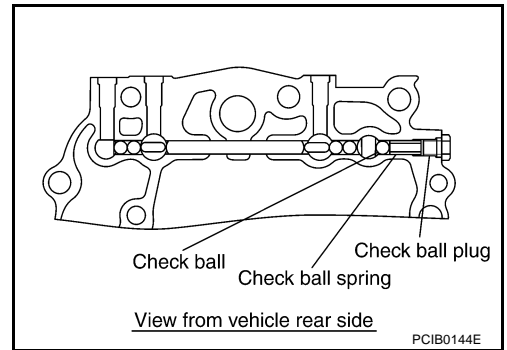

24. Install 3rd - 4th control lever assembly.

 : 20 - 23 N·m (2.1 - 2.3 kg·m, 15 - 16 ft·lb)

CAUTION:

Make sure the top and bottom are oriented correctly.

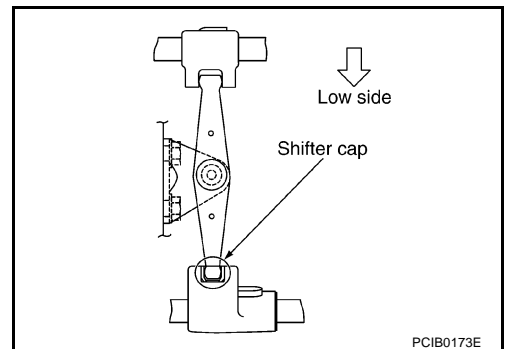

25. Insert check ball spring, steel ball, interlock pin, and interlock plunger into the adapter plate, apply genuine anaerobic liquid gasket or equivalent refer to GI section to the check ball plug threads, and tighten to the specified torque.

 : 13 - 17 N·m (1.4 - 1.7 kg·m, 10 - 12 ft·lb)

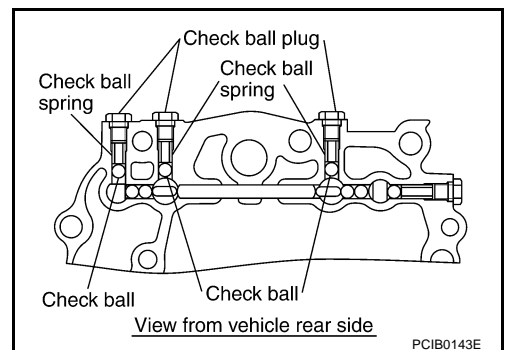

A
B
MT
D
E
F
G
H
I
J
K
L
M

TRANSMISSION ASSEMBLY

26. Install striking rod to adapter plate.
27. install striking lever and stoppering, low/high control lever to striking rod.
28. Using a pin punch [6 mm (0.24 in) dia.] to tap the retaining pin into the striking lever and stoppering and low/high control lever.

CAUTION:

Retaining pins are not reusable. Never reuse them.

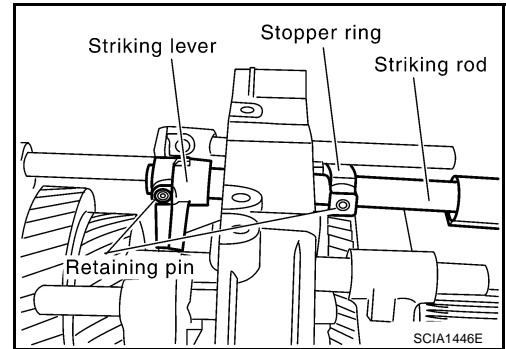

Case Components

1. Install counter front bearing in the transmission case.
2. Install oil gutter to transmission case.

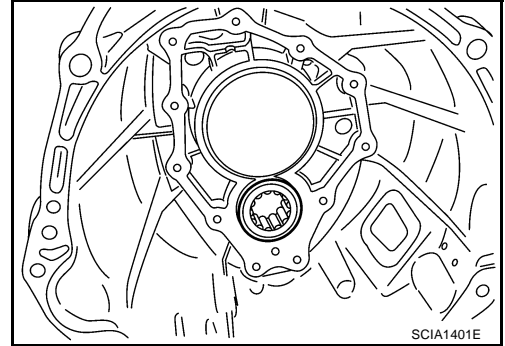

3. Apply genuine anaerobic liquid gasket or equivalent to the transmission case adapter plate mounting surface as shown in the figure.

CAUTION:

Complete remove all moisture and oil, etc., from the transmission case and adapter plate mounting surfaces.

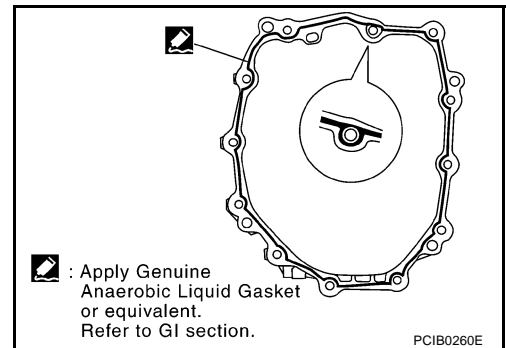

4. Place the adapter plate in the transmission case, using a plastic hammer to tap the adapter plate to install it into the transmission case.

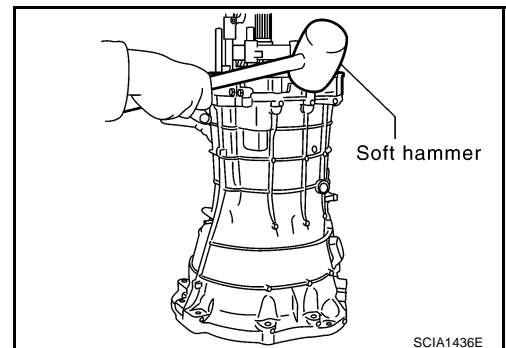

TRANSMISSION ASSEMBLY

5. Install snap ring, using snap ring pliers.

CAUTION:

Snap rings are not reusable. Never reuse them.

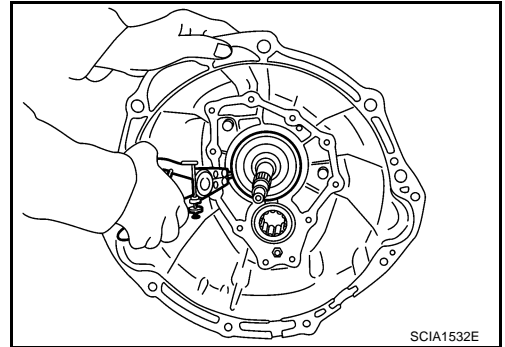

6. Tighten nuts shown in the figure.



: 4.9 - 5.6 N-m (0.50 - 0.57 kg-m, 44 - 49 in-lb)

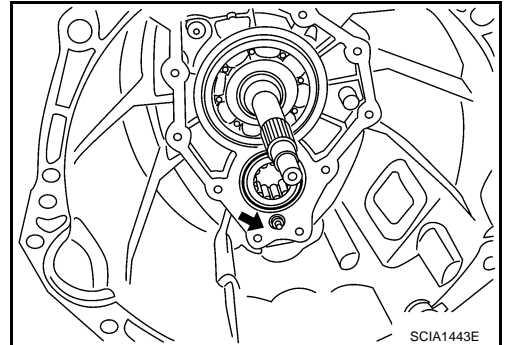

7. Apply multi-purpose grease to the lip of the oil seal. Using a drift, to install oil seal approx. 8.55-9.55 mm (0.336-0.376 in) above from the front cover edge surface.

Tool number : KV38102100 (J25803-01)

CAUTION:

- Oil seals are not reusable. Never reuse them.
- When installing, do not incline the oil seal.

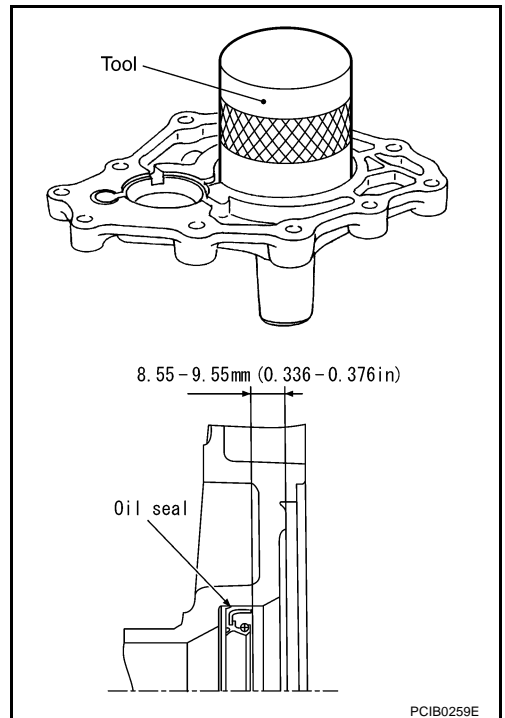

8. Install front cover gasket and front cover to transmission case.

CAUTION:

Gasket is not reusable, Never reuse them.

9. Temporary tightening 2 bolts in the positions shown in the figure.

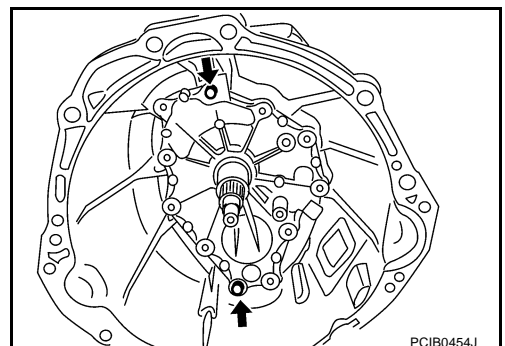

A
B
MT
D
E
F
G
H
I
J
K
L
M

TRANSMISSION ASSEMBLY

10. Insert remaining 9 bolts, tighten them to the specified torque.

 : 16 - 20 N-m (1.7 - 2.0 kg-m, 12 - 14 ft-lb)

CAUTION:

Four bolts pointed by arrows in the figure are not reusable.

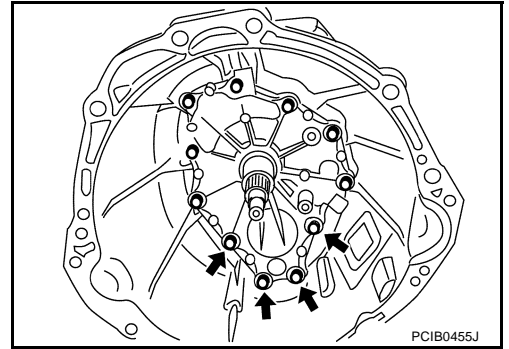

11. Tighten bolts to the specified torque in order.

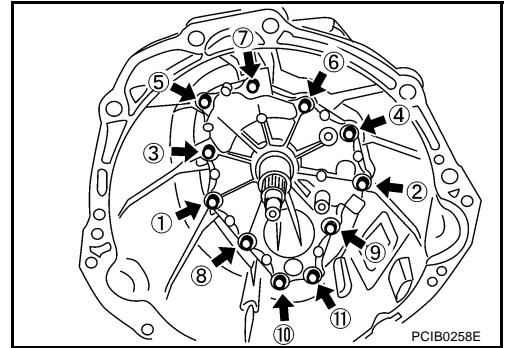

12. Install washer to withdrawal lever ball pin, and install it to front cover.

 : 38 - 41 N-m (3.9 - 4.1 kg-m, 28 - 30 ft-lb)

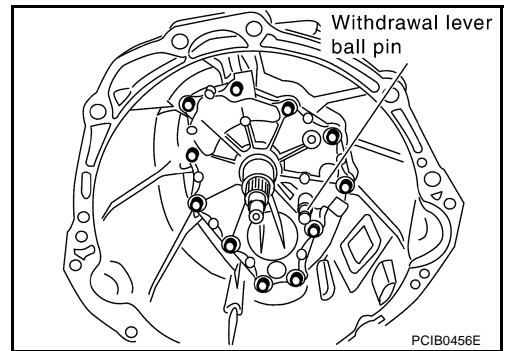

13. Install rear extension oil gutter.

14. Install reverse idler gear to adapter plate.

15. Apply multi -purpose grease to the oil seal lip, and then using the drift, to install control shaft oil seal.

Tool number : ST35291000 (—)

CAUTION:

- Oil seals are not reusable. Never reuse them.
- When installing, do not incline the oil seal.

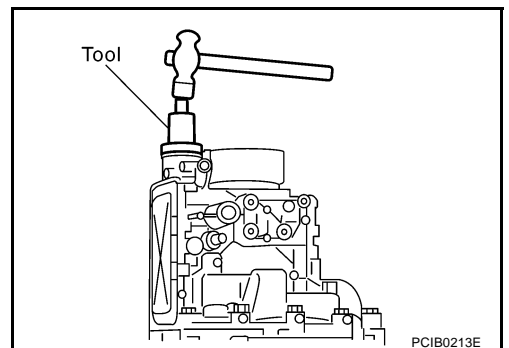

TRANSMISSION ASSEMBLY

16. Apply multi - purpose grease to the lip of the oil seal. Using a drift, to install oil seal. 1.2-2.2 mm (0.047-0.87 in) above from the rear extension case edge surface.

Tool number : ST33400001 (J26082)

CAUTION:

- Oil seals are not reusable. Never reuse them.
- When installing, do not incline the oil seal.

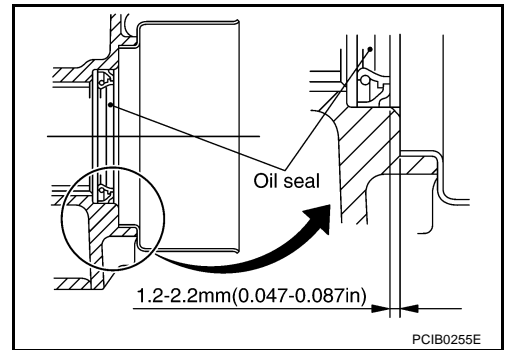

17. Apply genuine anaerobic liquid gasket or equivalent refer to GI section to the adapter plate rear extension mounting surface as shown in the figure.

CAUTION:

Completely remove all moisture, oil, etc., from the adapter plate and rear extension mounting surfaces.

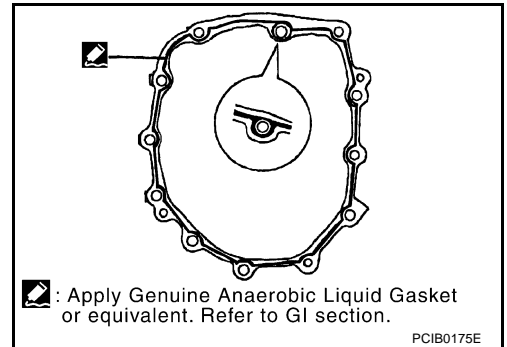

18. For rear extension case, tighten bolts to the specified torque in order as shown on the figure.

19. Install rear extension.

 : **24 - 31 N·m (2.5 - 3.1 kg·m, 18 - 22 ft·lb)**

20. Install control lever housing.

 : **17 - 22 N·m (1.8 - 2.2 kg·m, 13 - 16 ft·lb)**

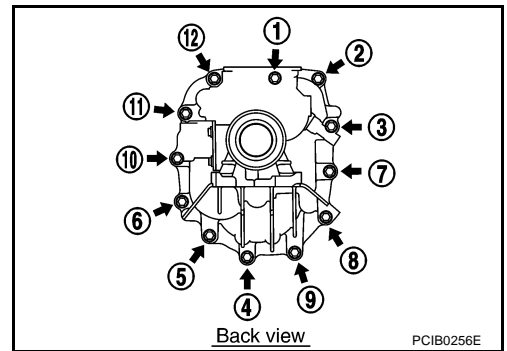

21. Install left/right return spring plugs. Insert return spring and plunger in the rear extension, apply sealant genuine anaerobic liquid gasket or equivalent to the return spring threads, and then tighten to the specified torque.

	Return spring identification mark	Plunger notch
RH	Brown	No
LH	Blue	Yes

 : **20 - 29 N·m (2.1 - 2.9 kg·m, 15 - 21 ft·lb)**

CAUTION:

The right and left return springs and plungers are different, so make sure they are installed correctly.

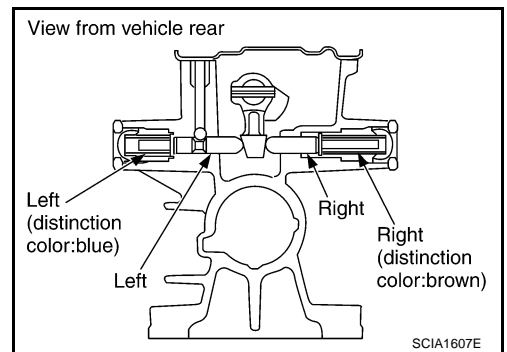

A
B
MT
D
E
F
G
H
I
J
K
L
M

TRANSMISSION ASSEMBLY

22. Install check shift pin as a signal unit with the control bracket.

 : 8.4 - 9.7 N·m (0.86 - 0.98 kg-m, 75 - 85 in-lb)

23. Install neutral position switch and reverse switch.

 : 23 - 33 N·m (2.4 - 3.3 kg-m, 17 - 24 ft-lb)

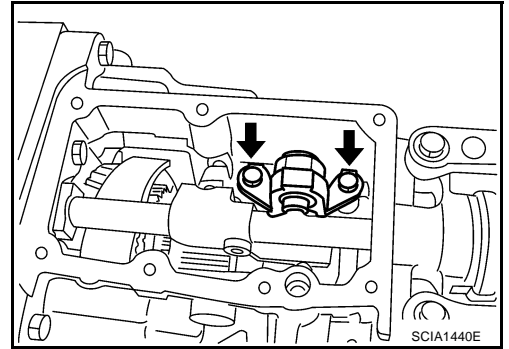

24. Install retaining pin into the control rod, using a pin punch [6 mm (0.24 in) dia.].

CAUTION:
Retaining pins are not reusable. Never reuse them.

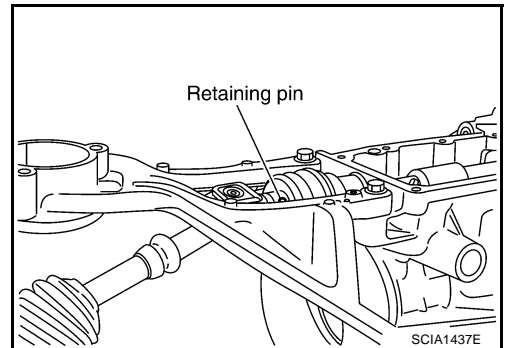

25. Install check select spring and check ball into the rear extension case.

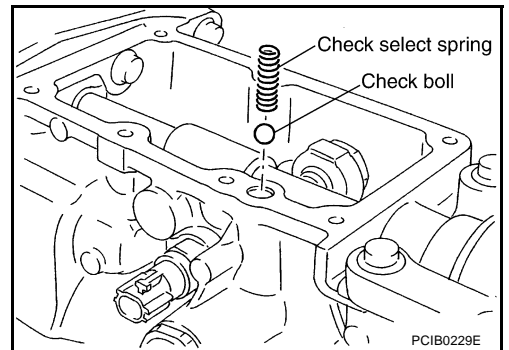

26. Insert rear extension upper cover gasket in to rear extension case.

CAUTION:
Gaskets are not reusable. Never reuse them.

27. Tighten rear extension upper cover bolts to specified torque, and then install rear extension upper cover.

 : 5.3 - 7.4 N·m (0.54 - 0.75 kg-m, 47 - 65 in-lb)

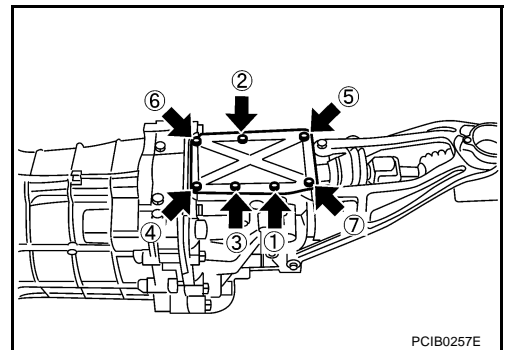

SERVICE DATA AND SPECIFICATIONS (SDS)

SERVICE DATA AND SPECIFICATIONS (SDS)

PFP:00030

General Specifications

ACS003TS

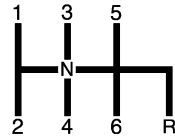
Applied model		VQ35DE	
Transmission		FS6R31A	
Model code number		CD000	CD005
Number of speed		6	
Shift pattern		 <p style="text-align: right; font-size: small;">SCIA0955E</p>	
Synchronmesh type		Warner	
Gear ratio	1st	3.794	
	2nd	2.324	
	3rd	1.624	
	4th	1.271	
	5th	1.000	
	6th	0.794	
	Reverse	3.446	
Main gear (Number of teeth)	Drive	26	
	1st	37	
	2nd	34	
	3rd	33	
	4th	31	
	6th	31	
	Reverse	42	
Counter gear (Number of teeth)	Drive	32	
	1st	12	
	2nd	18	
	3rd	25	
	4th	30	
	6th	48	
	Reverse	15	
Reverse idler gear (Number of teeth)		26	
Oil capacity ℓ (Imp pt)		Approx. 2.9 (3-1/4US qt, 2-3/4 Imp qt)	
Remarks	Reverse synchronizer	Installed	
	Double cone synchronizer	1st, 2nd	1st,3rd,4th
	Triple cone synchronizer	—	2nd

A
B
MT
D
E
F
G
H
I
J
K
L
M

SERVICE DATA AND SPECIFICATIONS (SDS)

End Play

ACS003TT

Unit: mm (in)

Item	Standard
Counter gear	0 - 0.10 (0 - 0.004)
Main drive gear	0 - 0.10 (0 - 0.004)
Mainshaft front	0 - 0.10 (0 - 0.004)
Mainshaft rear	0 - 0.10 (0 - 0.004)

Snap Rings

ACS003TU

Unit: mm (in)

Selective parts	Thickness	Part No.	
Main drive gear	1.89 (0.0744)	32204 01G60	
	1.95 (0.0768)	32204 01G61	
	1.99 (0.0783)	32204 01G62	
	2.03 (0.0799)	32204 01G63	
	2.07 (0.0815)	32204 01G64	
	2.11 (0.0831)	32204 01G65	
Counter gear	1.96 (0.0772)	32236 CD000	
	2.02 (0.0795)	32236 CD001	
	2.08 (0.0819)	32236 CD002	
	2.14 (0.0843)	32236 CD003	
	2.20 (0.0866)	32236 CD004	
	2.26 (0.0890)	32236 CD005	
	2.32 (0.0913)	32236 CD006	
	2.38 (0.0937)	32236 CD007	
	2.44 (0.0961)	32236 CD008	
	2.50 (0.0984)	32236 CD009	
Mainshaft	2.56 (0.1008)	32236 CD010	
	2.62 (0.1031)	32236 CD011	
	Front side	2.08 (0.0819)	32204 CD000
		2.14 (0.0843)	32204 CD001
		2.20 (0.0866)	32204 CD002
		2.26 (0.0890)	32204 CD003
	Shaft rear-end	2.08 (0.0819)	32204 CD000
		2.14 (0.0843)	32204 CD001
		2.20 (0.0866)	32204 CD002
		2.26 (0.0890)	32204 CD003
		2.32 (0.0913)	32204 CD004
		2.38 (0.0937)	32204 CD005
		2.44 (0.0961)	32204 CD006
		2.50 (0.0984)	32204 CD007
2.56 (0.1008)		32204 CD008	
2.62 (0.1031)		32204 CD009	
2.68 (0.1055)	32204 CD010		
2.74 (0.1079)	32204 CD011		
2.80 (0.1102)	32204 CD012		
2.86 (0.1126)	32204 CD013		
2.92 (0.1150)	32204 CD014		
2.98 (0.1173)	32204 CD015		

SERVICE DATA AND SPECIFICATIONS (SDS)

Baulk Ring Clearance (Model code number. CD000)

ACS003TV

Unit: mm (in)

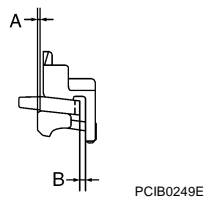
Measurement point	Standard	Limit value
1st & 2nd (Double - cone synchronizer)	Inner baulk ring clearance "A" Outer baulk ring clearance "B"	A: 0.50 - 0.70 (0.020 - 0.028) B: 1.00 - 1.50 (0.039 - 0.059)
		
3rd & 4th, 5th & 6th	0.70 - 1.25 (0.028 - 0.049)	0.5 (0.020)
Reverse	0.75 - 1.20 (0.030 - 0.047)	0.5 (0.020)

Baulk Ring Clearance (Model code number. CD005)

ACS004LX

Unit: mm (in)

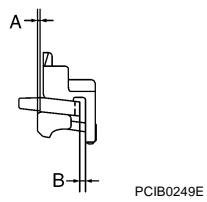
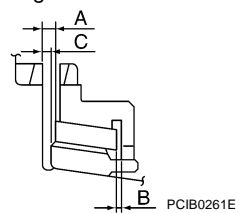
Measurement point	Standard	Limit value
1st & 3rd & 4th (Double - cone synchronizer)	Inner baulk ring clearance "A" Outer baulk ring clearance "B"	A: 0.50 - 0.70 (0.020 - 0.028) B (1st): 1.00 - 1.50 (0.039 - 0.059) B (3rd, 4th): 0.85 - 1.35 (0.033 - 0.053)
		
2nd (Triple - cone synchronizer)	Main gear taper cone clearance "A" Outer baulk ring clearance "B" Inner baulk ring clearance "C"	A: 0.60 - 1.30 (0.024 - 0.051) B: 0.85 - 1.35 (0.033 - 0.053) C: 0.70 - 1.25 (0.028 - 0.049)
		
5th & 6th	0.70 - 1.25 (0.028 - 0.049)	0.5 (0.020)
Reverse	0.75 - 1.20 (0.030 - 0.047)	0.5 (0.020)

SERVICE DATA AND SPECIFICATIONS (SDS)
