

This document is not an API Standard; it is under consideration within an API technical committee but has not received all approvals required to become an API Standard. It shall not be reproduced or circulated or quoted, in whole or in part, outside of API committee activities except with the approval of the Chairman of the committee having jurisdiction and staff of the API Standards Dept. Copyright API. All rights reserved.

## **Manual of Petroleum Measurement Standards Chapter 7.1**

### **Temperature Determination – Liquid-in-Glass Thermometers**

Ballot Draft

This document is not an API Standard; it is under consideration within an API technical committee but has not received all approvals required to become an API Standard. It shall not be reproduced or circulated or quoted, in whole or in part, outside of API committee activities except with the approval of the Chairman of the committee having jurisdiction and staff of the API Standards Dept. Copyright API. All rights reserved.

|  |    |
|--|----|
| INTRODUCTION.....  | 1  |
| 1 SCOPE .....  | 1  |
| 2 NORMATIVE REFERENCES .....   | 1  |
| 3 TERMS AND DEFINITIONS .....  | 3  |
| 3.1 degree.....  | 3  |
| 3.1.1 degree Celsius (°C).....   | 3  |
| 3.1.2 degree centigrade .....  | 3  |
| 3.1.3 degree Fahrenheit (°F).....  | 3  |
| 3.2 discrimination .....   | 3  |
| 3.3 thermometer.....   | 3  |
| 3.3.1 liquid-in-glass thermometer (LIGT) .....   | 4  |
| 3.3.2 low-hazard liquid .....  | 4  |
| 3.3.3 mercury-in-glass thermometer (MIGT).....   | 4  |
| 3.3.4 partial immersion thermometer .....  | 4  |
| 3.3.5 total immersion thermometer .....  | 4  |
| 4 GENERAL PRECAUTIONS .....  | 4  |
| 4.1 Safety.....  | 4  |
| 4.1.1 Mercury Warning.....   | 5  |
| 5 UNITS OF MEASURE .....   | 5  |
| 6 EQUIPMENT AND DESIGN REQUIREMENTS.....   | 5  |
| 6.1 Liquid-in-Glass Thermometers.....  | 5  |
| 6.1.1 General Information .....  | 5  |
| 6.2 Liquid-in-Glass Thermometer Assemblies .....   | 8  |
| 6.2.1 Cup-Case Assembly .....  | 8  |
| 6.2.2 Armored Case Assembly .....  | 9  |
| 6.2.3 Angle-Stem Assembly.....   | 10 |
| 6.3 Thermowells.....   | 11 |
| 6.3.1 Test Thermowells.....  | 11 |
| 6.3.2 Sensor Thermowells .....   | 11 |
| 6.3.3 Selection of Thermowell.....   | 11 |
| 6.3.4 Pressure Rating .....  | 11 |
| 6.3.5 Installation.....  | 12 |
| 6.3.6 Material .....   | 12 |
| 6.3.7 Thermal Conductivity .....   | 12 |
| 7 PROCEDURES FOR TEMPERATURE DETERMINATION.....  | 12 |
| 7.1 Static Temperature Determination Using Liquid-in-Glass Thermometers  | 12 |
| 7.1.1 General Information .....  | 12 |
| 7.1.2 Procedures for Static Temperature Determination in Non or Low Pressure<br>Tanks and Cargo Carriers ..... | 16 |
| 7.1.3 Procedures for Static Temperature Determination in Pressure Storage Tanks<br>and Cargo Carriers.....     | 20 |
| 7.2 Dynamic Temperature Determination Using Liquid-in-Glass Thermometers                                       | 22 |
| 7.2.1 General Information .....  | 22 |
| 7.2.2 Temperature Discrimination .....   | 22 |
| 7.2.3 Dynamic Temperature Determination .....  | 23 |

This document is not an API Standard; it is under consideration within an API technical committee but has not received all approvals required to become an API Standard. It shall not be reproduced or circulated or quoted, in whole or in part, outside of API committee activities except with the approval of the Chairman of the committee having jurisdiction and staff of the API Standards Dept. Copyright API. All rights reserved.

|       |  |    |
|-------|--|----|
| 8     | INSPECTION, VERIFICATION, AND CALIBRATION REQUIREMENTS | 23 |
| 8.1   | Inspection.....  | 23 |
| 8.1.1 | General .....  | 23 |
| 8.1.2 | New and Recalibrated Thermometers .....                | 23 |
| 8.1.3 | Cleaning.....  | 23 |
| 8.2   | Verification .....                                     | 24 |
| 8.2.1 | Tolerances .....                                       | 24 |
| 8.2.2 | Single-point Verification .....                        | 24 |
| 8.2.3 | Multipoint Verification.....                           | 24 |
| 8.2.4 | Prior-to-use Verification .....                        | 24 |
| 8.2.5 | Periodic Verification .....                            | 25 |
| 8.2.6 | Ice-point Bath Preparation .....                       | 25 |
| 8.3   | Calibration.....                                       | 25 |
| 8.3.1 | General .....  | 25 |
| 8.3.2 | Mercury-in-Glass Tank Thermometers .....               | 26 |
| 8.3.3 | Low-hazard Liquid-in-Glass Tank Thermometers .....     | 26 |
| 8.3.4 | Reference Thermometers .....                           | 26 |
| 8.3.5 | Calibration Documentation or Certificates.....         | 26 |
| 8.3.6 | Calibration Correction Factors .....                   | 27 |

## ANNEXES

|   |    |
|---|----|
| Annex A (Informative) Mercury-in-Glass Thermometer Alternative Testing Phase I<br>- Tank Measurement .....                          | 28 |
| Annex B (Normative) Emergent-Stem Correction for Liquid-in-Glass Thermometers<br>.....  | 30 |
| Annex C (Informative) Test Procedure for Determining Immersion Times of Liquid-in-<br>Glass Thermometers and their Assemblies ..... | 37 |
| Annex D Local Direct-Reading Thermometers .....   | 40 |

## FIGURES

|   |    |
|---|----|
| Figure 1 Types of Glass Thermometers and Their Use .....  | 6  |
| Figure 2 Typical Cup-Case Assembly .....  | 9  |
| Figure 3 Typical Armored-Stem Assembly .....  | 10 |
| Figure 4 Typical Angle-Stem Thermometer.....  | 11 |
| Figure B-1 Thermometers Immersed in Bath.....   | 30 |
| Figure B-2 Total Immersion Thermometer Partially Immersed in a Thermowell.....                            | 31 |
| Figure B-3 Clip to Suspend Ambient Temperature Thermometer.....   | 32 |
| Figure B-4 Measuring Temperature of Emergent Liquid Column .....  | 32 |
| Figure B-5 Measuring Between Immersion Ring and Start of Temperature<br>Scale (34 mm).....                | 34 |
| Figure B-6 Determining How Many Degrees on the Thermometer Scale Corresponds<br>to 34 mm (7 degrees)..... | 34 |

This document is not an API Standard; it is under consideration within an API technical committee but has not received all approvals required to become an API Standard. It shall not be reproduced or circulated or quoted, in whole or in part, outside of API committee activities except with the approval of the Chairman of the committee having jurisdiction and staff of the API Standards Dept. Copyright API. All rights reserved.

## TABLES

|   |    |
|---|----|
| Table 1 Maximum Deviation Limits: Operating Thermometer Versus Reference Thermometer .....  | 6  |
| Table 2 Tank Thermometers .....   | 7  |
| Table 3 Dynamic Temperature Thermometers.....   | 8  |
| Table 4 Minimum Number of Temperature Measurements for Various Depths of Hydrocarbon Liquid in Storage, Lease, Ship and Barge Tanks ..... | 13 |
| Table 5 Recommended Immersion Times for Woodback Cup-Case Assemblies .  | 15 |
| Table 6 Thermometer Assemblies and Temperature Levels for Tanks and Cargo Carriers .....  | 19 |
| Table 7 Temperature Measurements for Horizontal Cylindrical Tanks.....  | 20 |
| Table C-1 Suggested Bath Temperature .....  | 38 |
| Table C-2 Time Intervals for Reading Thermometers .....   | 38 |
| Table D-1 Tank Appurtenances for Temperature Measurement .....  | 40 |

# Manual of Petroleum Measurement Standards

## API MPMS Chapter 7.1 — Liquid-in-Glass Thermometers

### INTRODUCTION

This section describes how to correctly use various types of liquid-in-glass thermometers to accurately determine the temperatures of hydrocarbon liquids under both static and dynamic conditions. However for specifics on using liquid-in-glass thermometers for dynamic measurement see API *MPMS* Ch. 7.4. These temperatures are used to convert hydrocarbon liquid volumes to base conditions. Other methods, equipment, and procedures for temperature determination are described in the other sub-sections of API *MPMS* Ch. 7. The method and equipment selection for temperature determination are left to the discretion of the parties involved.

### 1 SCOPE

This chapter describes the methods, equipment, and procedures for manually determining the temperature of liquid petroleum and petroleum products under both static and dynamic conditions with liquid-in-glass thermometers. This chapter discusses temperature measurement requirements in general for custody transfer, inventory control, and marine measurements. The actual method and equipment selected for temperature determination are left to the agreement of the parties involved.

The manual method covers:

- Non-pressurized tanks and non-pressurized marine vessels
- Gas-blanketed tanks and gas-blanketed marine vessels

It does not cover hydrocarbons under pressures in excess of 21 kPa (3 psi gauge) or cryogenic temperature measurement, unless equipped with a thermowell.

The requirements of this chapter are based on practices for crude oils and petroleum products covered by API *MPMS* Ch. 11.1 (ASTM D1250). Requirements in this chapter may be used for other fluids and other applications. However, other applications may require different performance and installation specifications.

### 2 NORMATIVE REFERENCES

#### API

Manual of Petroleum Measurement Standards

Chapter 1, *Vocabulary*

Chapter 2, (all sections) *Calibration of Upright Cylindrical Tanks*

Chapter 3, (all sections) *Tank Gauging*

Chapter 8.1, *Standard Practice for Manual Sampling of Petroleum and Petroleum Products*

Chapter 11.1, *Physical Properties Data, Temperature and Pressure Volume Correction Factors for Generalized Crude Oils, Refined Products, and Lubricating Oils*

Chapter 12.1.1, *Calculation of Static Petroleum Quantities – Upright Cylindrical Tanks and Marine Vessels*

Chapter 12.2, *Calculation of Petroleum Quantities Using Dynamic Methods and Volumetric Correction Factors*

Chapter 15, *Guidelines for Use of the International System of Units (SI) in the Petroleum and Allied Industries*

Chapter 18.1, *Custody Transfer – Measurement Procedure for Crude Oil gathered From Lease Tanks by Truck*

RP 500, *Recommended Practice for Classifications of Locations for Electrical Installations at Petroleum Facilities Classified as Class I, Division 1 and Division 2*

RP 2003, *Protection Against Ignitions Arising Out of Static, Lightning, and Stray Currents*

RP 3000, *Classifying and Loading of Crude Oil into Rail Tank Cars*

#### **ASTM<sup>1</sup>**

D1250, *Standard Guide for Use of the Petroleum Measurement Tables*

E1, *Standard Specification for ASTM Liquid-in-Glass Thermometers*

E77, *Standard Test Method for Inspection and Verification of Thermometers*

E344, *Terminology Relating to Thermometry and Hydrometry*

E2251, *Standard Specification for Liquid-in-Glass ASTM Thermometers with Low-Hazard Precision Liquids*

#### **OCIMF<sup>2</sup>**

*International Safety Guide for Oil Tankers and Terminals (ISGOTT)*

#### **IMO<sup>3</sup>**

*Safety of Life at Sea (SOLAS)*

#### **NIST<sup>4</sup>**

NIST Special Publication 1088, *Maintenance, Validation, and Recalibration of Liquid-in-Glass Thermometers*

#### **NFPA<sup>5</sup>**

NFPA 70, *National Electrical Code*

---

<sup>1</sup> American Society for Testing and Materials, 100 Barr Harbor Drive, West Conshohocken, PA 19428

<sup>2</sup> Oil Companies International Marine Forum, 6<sup>th</sup> Floor, Portland House, Stag Place, London SW1E 5BH

<sup>3</sup> International Maritime Organization, 4 Albert Embankment, London SE1 7SR

<sup>4</sup> National Institute of Standards and Technology, 100 Bureau Drive, Stop 1070, Gaithersburg, MD 20899

<sup>5</sup> National Fire Prevention Association, 1 Batterymarch Park, Quincy, MA 02169

### 3 TERMS AND DEFINITIONS

For the purpose of this document, the following definitions apply. Refer to API Manual of Petroleum Measurement Standards (*MPMS*) Chapter 1 and ASTM E344 for the definition of additional terms used in this standard.

#### 3.1

##### **degree**

##### 3.1.1

##### **degree Celsius (°C)**

A derived unit of temperature in the International System of Units (SI).

##### 3.1.2

##### **degree centigrade**

Obsolete term, use degree Celsius.

##### 3.1.3

##### **degree Fahrenheit (°F)**

A non-SI unit of temperature used in the US Customary (USC) system of units. At any temperature, an interval of one degree Fahrenheit is the same as an interval of 5/9 degree Celsius.

#### 3.2

##### **discrimination**

The ability to sense and record the actual temperature of a liquid to the specified temperature increments.

#### 3.3

##### **thermometer**

A device that measures temperature using any of a variety of different principles. A thermometer has two important components: a temperature sensor in which some physical change occurs that is dependent on temperature, and some means of indicating and/or transmitting this physical change as a value.

### 3.3.1

#### **liquid-in-glass thermometer (LIGT)**

A glass thermometer containing mercury or a low-hazard liquid that indicates the temperature being measured.

### 3.3.2

#### **low-hazard liquid**

A liquid that is biodegradable, non-hazardous and considered non-toxic in thermometer quantities.

### 3.3.3

#### **mercury-in-glass thermometer (MIGT)**

A glass thermometer containing mercury that indicates the temperature being measured.

### 3.3.4

#### **partial immersion thermometer**

A liquid-in-glass thermometer designed to indicate temperatures correctly when the bulb and a specified part of the stem are exposed to the temperature being measured.

### 3.3.5

#### **total immersion thermometer**

A liquid-in-glass thermometer designed to indicate temperatures correctly when just that portion of the thermometer containing the liquid is exposed to the temperature being measured.

## 4 GENERAL PRECAUTIONS

### 4.1 Safety

Safety shall be considered for the specification, installation and operation of all equipment. Refer to API RP 500 and NFPA 70 for guidance. When loading liquids that can accumulate static charges, refer to the precautions described in the *International Safety Guide for Oil Tankers and Terminals*, *Safety of Life at Sea*, API MPMS Ch. 3, and API RP 2003. Care must be taken with all liquid-in-glass thermometers to prevent breakage, which will result in a safety hazard. If the liquid in the thermometer is mercury, additional care must be taken.



### 4.1.1 Mercury Warning

**WARNING:** Mercury has been designated by EPA and many state agencies as a hazardous material that can cause central nervous system, kidney and liver damage. Mercury, or its vapor, may be hazardous to health and corrosive to materials. Caution should be taken when handling mercury and mercury containing products. See the applicable product Safety Data Sheet (SDS) or Material Safety Data Sheet (MSDS) for details and the EPA website <http://www.epa.gov/mercury/faq.htm> for additional information. Users should be aware that selling mercury and/or mercury containing products into your state may be prohibited by state law.

## 5 UNITS OF MEASURE

For custody transfer, the means of temperature determination should be agreed to among the parties involved. Temperatures referenced in this document are those defined by the International Temperature scale of 1990 (ITS-90). Temperatures may be measured and expressed in degrees Celsius or in degrees Fahrenheit. This standard presents both the International System of Units (SI) and the US Customary (USC) system of units, and either may be implemented. The presentations of both units are for the convenience of the user, and are not necessarily exact conversions. The units of implementation are typically determined by contract, regulatory requirement, the manufacturer, or the user's calibration program. Once a system of units is chosen for a given application, they should not be arbitrarily changed. (See API MPMS Ch. 15.)

## 6 EQUIPMENT AND DESIGN REQUIREMENTS

### 6.1 Liquid-in-Glass Thermometers

#### 6.1.1 General Information

Due to the identified hazards associated with mercury-in-glass thermometers (MIGTs), they are being phased out of use. API, in collaboration with the U.S. Environmental Protection Agency, conducted a comparison study of MIGTs to other liquid-in-glass and digital thermometers in order to provide a comparison of the accuracies of each type of device. The testing indicated that alternative liquid-in-glass thermometers meeting the requirements in ASTM E2251 can be substituted for MIGTs. Annex A provides additional details of the testing that was conducted.

##### 6.1.1.1 Thermometer Specifications

Glass thermometers include partial immersion thermometers and total immersion thermometers (see Figure 1 and refer to ASTM E344). These thermometers should conform to the specifications in ASTM E1 or E2251 for thermometers or to the National Institute of Standards and Technology (NIST) specifications. Calibration does not have to be done by a national metrology institute (NMI, e.g., NIST in the United States), but the certified instruments used for the calibration shall be traceable to a NMI.

No ASTM thermometer is designed to be used at full or complete immersion. However, tank thermometers used in conjunction with a cup-case assembly are completely immersed into the tank, but when read are actually partial immersion. No ASTM alternative liquid tank thermometer may be used as partial immersion unless stem corrections are available from the manufacturer. Figure 1 illustrates the difference between total immersion and partial immersion thermometers.

Operating thermometers that are used in static or dynamic measurement shall be compared on a regular basis (see Section 8) to a temperature standard. The recommended allowable tolerances between the operating thermometer and the NMI traceable thermometer are shown in Table 1, and are provided as a reference for limits considered acceptable for static and dynamic temperature determinations in custody transfer measurement of petroleum and petroleum products.

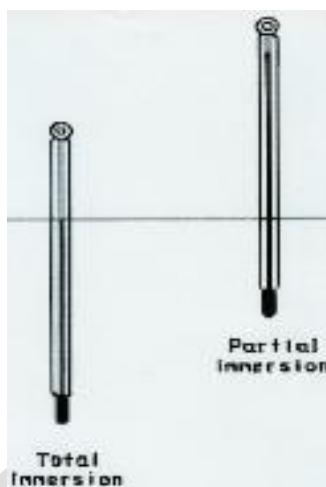

Figure 1 - Types of Glass Thermometers and Their Use

Table 1—Allowable Tolerances: Operating Thermometer Versus Temperature Standard

| Service                          | °C    | °F   |
|----------------------------------|-------|------|
| Ambient Temperature Measurement  | ±1    | ±2   |
| Static Measurement               | ±0.30 | ±0.5 |
| Quantity Transaction Record      | ±0.25 | ±0.5 |
| Meter Proving                    | ±0.25 | ±0.5 |
| Base Prover Volume Determination | ±0.05 | ±0.1 |
| Density Meter Proving            | ±0.1  | ±0.2 |
| Density Meter Calibration        | ±0.05 | ±0.1 |

#### 6.1.1.2 Permanent Glass Thermometers

Securely mount permanently installed glass thermometers in a thermowell and protected from breakage by the use of a housing. They shall have the same high resolution scale graduation

interval and tolerance as glass test thermometers. These thermometers shall be calibrated and checked using test thermometers as described in Section 8.

### 6.1.1.3 Tank Thermometers

Tank thermometers shall be of the total immersion type and shall be made in accordance with the specifications in ASTM E1 or E2251. Each thermometer shall be the liquid-in-glass type with nitrogen or another suitable inert gas filling the space above the liquid column and with graduation marks permanently etched on its glass stem. Angle-stem thermometers may use a separate graduated scale, as discussed in Section 6.2.3. The thermometers listed in Table 2 shall be used.

Table 2 – Tank Thermometers

| Name                          | ASTM Thermometer | Range             | Graduation | Accuracy |
|-------------------------------|------------------|-------------------|------------|----------|
| ASTM Tank                     | 58C-86           | -34 °C to +49 °C  | 0.5 °C     | ±0.3 °C  |
| ASTM Tank                     | 58F-86           | -30 °F to +120 °F | 1 °F       | ±0.5 °F  |
| ASTM Tank                     | S58C-11          | -34 °C to +49 °C  | 0.5 °C     | ±0.3 °C  |
| ASTM Tank                     | S58F-11          | -30 °F to +120 °F | 1 °F       | ±0.5 °F  |
| ASTM Tank                     | 59C-86           | -18 °C to +82 °C  | 0.5 °C     | ±0.3 °C  |
| ASTM Tank                     | 59F-86           | 0 °F to +180 °F   | 1 °F       | ±0.5 °F  |
| ASTM Tank                     | S59C-03          | -18 °C to +82 °C  | 0.5 °C     | ±0.3 °C  |
| ASTM Tank                     | S59F-03          | 0 °F to +180 °F   | 1 °F       | ±0.5 °F  |
| ASTM Tank                     | 60C-86           | 77 °C to +260 °C  | 1 °C       | ±0.5 °C  |
| ASTM Tank                     | 60F-86           | 170 °F to +500 °F | 2 °F       | ±1.0 °F  |
| ASTM Tank                     | 97C-86           | -18 °C to +49 °C  | 0.5 °C     | ±0.3 °C  |
| ASTM Tank                     | 97F-86           | 0 °F to +120 °F   | 1 °F       | ±0.5 °F  |
| ASTM Tank                     | 98C-86           | 16 °C to +82 °C   | 0.5 °C     | ±0.3 °C  |
| ASTM Tank                     | 98F-86           | 60 °F to +180 °F  | 1 °F       | ±0.5 °F  |
| ASTM Tank                     | 130C-90          | -7 °C to +105 °C  | 0.5 °C     | ±0.5 °C  |
| ASTM Tank                     | 130F-90          | 20 °F to +220 °F  | 1 °F       | ±1.0 °F  |
| ASTM Tank                     | S130C-10         | -7 °C to +105 °C  | 0.5 °C     | ±0.5 °C  |
| ASTM Tank                     | S130F-10         | 20 °F to +220 °F  | 1 °F       | ±1.0 °F  |
| Angle-stem                    | --               | Suitable range    | 1 °F       | ±1.0 °F  |
| Tank thermometer <sup>a</sup> | --               | 20 °F to 220 °F   | 1 °F       | ±0.5 °F  |

Notes:

1. ASTM Thermometer designations that start with S (e.g., S58C-11) are liquid-in-glass thermometers with low-hazard liquid (ASTM E2251)
  2. Except for the angle-stem thermometer, all of the thermometers listed in this table are the total immersion type.
  3. Length of all thermometers but angle-stem is 300 mm to 305 mm (12 in)
  4. Length of angle-stem thermometer graduated portion is 300 mm to 305 mm (12 in)
- <sup>a</sup> This thermometer does not have an ASTM designation, but it is commonly used for certain heated materials.

### 6.1.1.4 Dynamic Measurement Thermometers

ASTM E1 glass thermometers that meet the discrimination requirements for dynamic measurement are shown in Table 3. These glass thermometers are designed and calibrated for immersion to the scale level corresponding to the temperature of the liquid. These

thermometers normally have scale graduations of either 0.1 °C or 0.5 °C (0.2 °F or 1.0 °F) and a tolerance of either ±0.1 °C or ±0.25 °C (±0.2 °F or ±0.5 °F). When used in a manner other than total immersion, errors due to the differential expansion of the glass and liquid column in the stem may be experienced.

When used for meter prover calibration and for checking and calibrating temperature devices used for meter proving, potential scale errors and stem corrections shall be analyzed, and corrections should be applied. Normally, stem corrections are not significant unless the difference between the average stem temperature and liquid temperature is greater than 8 °C (15 °F). Consider the stem correction on a case-by-case basis. Annex B provides information about the methods for stem correction.

Table 3 – Dynamic Temperature Thermometers

| Name           | ASTM Thermometer | Range             | Graduation | Accuracy |
|----------------|------------------|-------------------|------------|----------|
| ASTM Tank      | 58C-86           | -34 °C to +49 °C  | 0.5 °C     | ±0.3 °C  |
| ASTM Tank      | 58F-86           | -30 °F to +120 °F | 1 °F       | ±0.5 °F  |
| ASTM Tank      | 59C-86           | -18 °C to +82 °C  | 0.5 °C     | ±0.3 °C  |
| ASTM Tank      | 59F-86           | 0 °F to +180 °F   | 1 °F       | ±0.5 °F  |
| ASTM Precision | 63C-86           | -8 °C to +32 °C   | 0.1 °C     | ±0.1 °C  |
| ASTM Precision | 63F-86           | +18 °F to +89 °F  | 0.2 °F     | ±0.2 °F  |
| ASTM Precision | 64C-86           | +25 °C to +55 °C  | 0.1 °C     | ±0.1 °C  |
| ASTM Precision | 64F-86           | +77 °F to +131 °F | 0.2 °F     | ±0.2 °F  |
| ASTM Precision | 65C-86           | +50 °C to +80 °C  | 0.1 °C     | ±0.1 °C  |
| ASTM Precision | 65F-86           | +122 °F to 176 °F | 0.2 °F     | ±0.2 °F  |

Notes:

1. Length of all ASTM Tank thermometers is 300 mm to 305 mm (12 in)
2. Length of all ASTM Precision thermometers is 374 mm to 384 mm (15 in)
3. The Name designations ASTM Tank and ASTM Precision are the names designated in ASTM E1

## 6.2 Liquid-in-Glass Thermometer Assemblies

### 6.2.1 Cup-Case Assembly

Make the cup-case assembly shown in Figure 2 of either varnished hardwood or non-sparking, corrosion-resistant material. It shall have a cup with a capacity of at least 100 mL (6.1 in<sup>3</sup>) and with dimensions such that the side of the bulb will be at least 9.5 mm (<sup>3</sup>/<sub>8</sub> in) from the nearest wall and the bottom of the bulb will be 25.4 mm ±5.0 mm (1 in ±3/16 in) above the bottom of the cup.

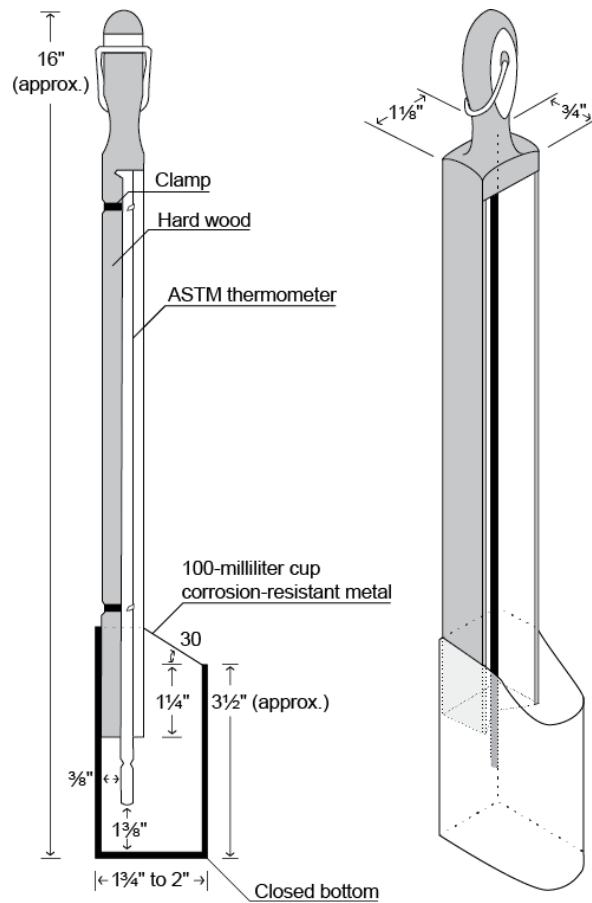

Figure 2 - Typical Cup-Case Assembly

### 6.2.2 Armored Case Assembly

Make the armored-case assembly shown in Figure 3 of non-sparking, corrosion-resistant tubing that does not exceed 13 mm ( $\frac{1}{2}$  in) in outside diameter. Either total or partial immersion thermometers may be used in armored case assemblies, but care must be taken to keep the assembly immersed to the proper level in the liquid when the thermometer is read.

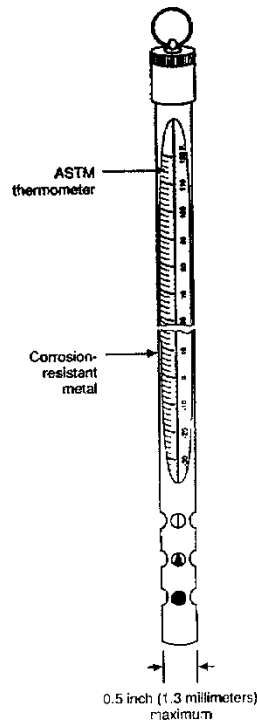

Figure 3 - Typical Armored-Case Assembly

### 6.2.3 Angle-Stem Assembly

The angle-stem thermometer in Figure 4 is installed in a standard metal-separable well or socket in a tank. For vertical tanks with capacities greater than 1590 m<sup>3</sup> (10,000 bbl), the glass stem of the thermometer shall be at least 0.9 m (3 ft) long, excluding the graduated portion, and shall be protected with a light metal tube. For storage tanks with capacities less than 1590 m<sup>3</sup> (10,000 bbl), the stem may be 0.3 m (1 ft) long, excluding the graduated portion, and also shall be protected with a light metal tube. The sensitive portion of the thermometer shall not exceed 60 mm (2.5 in), and the stem may have an angle of 90 degrees or greater to conform to the contour of the tank shell.

Attach the assembly to the well by a threaded coupling. A thermometer with a separate graduated scale is acceptable as long as the markings on the scale are permanently engraved and temperature lines at approximately 27 °C (80 °F) intervals are etched on the glass stem of the thermometer to coincide with the corresponding lines on the scale.

In addition to applications discussed in this section, angle-stem thermometers may be used in pipeline metering and prover applications to measure the temperature of the proving medium, but shall not be used for custody transfer measurement.

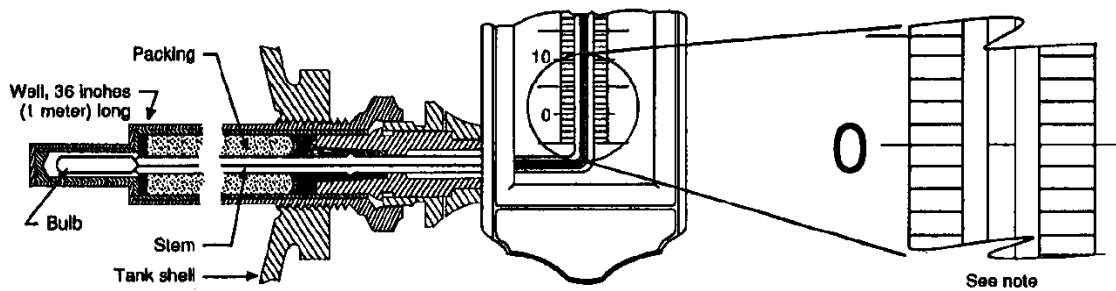

Note: The etched reference line on the glass must be aligned with zero on the scale.

Figure 4 - Typical Angle-Stem Thermometer

### 6.3 Thermowells

The use of thermowells is required in dynamic temperature measurement to isolate the liquid material from the temperature sensor. There are two general classification types of thermowells: test wells and sensor wells.

#### 6.3.1 Test Thermowells

Test wells are thermowells installed for occasional use (temperature checking), and capped when not in use. Test wells shall be installed adjacent to sensor wells. A suggested location is within three (3) pipe diameters between the test well and sensor well. Capping prevents foreign material from accumulating in the well bore. The test well should be the same type as the sensor well which is used for the working device, but as a minimum the test well shall have the same insertion length and a bore large enough to allow the use of a liquid-in-glass thermometer. A clogged thermowell may cause measurement errors and may damage thermometers. It is recommended that thermowells be checked periodically for an accumulation of foreign material and cleaned if needed.

#### 6.3.2 Sensor Thermowells

Sensor wells are thermowells installed for use with a permanently installed temperature sensor, and shall be matched to the temperature sensing device (thermometer, transmitter, etc.).

#### 6.3.3 Selection of Thermowell

Thermowells shall be based on the application criteria below. Design the thermowells to resist flow-induced vibration.

#### 6.3.4 Pressure Rating

The thermowell selected shall comply with design codes for the operating pressures and temperatures of the system.

### **6.3.5 Installation**

Select the thermowell to conform to code and user installation practices. Thermowells are typically threaded, welded, or flange mounted. The immersion length of the thermowell should be sufficient to put the sensor element within the center one-third of the pipe diameter or provide immersion of 0.3 m (1 ft) unless limited by fluid velocity considerations. Install the thermowell in as near to a vertical position as practical to allow it to be filled with an appropriate heat-conducting material.

### **6.3.6 Material**

Construct the thermowell of a material that is compatible with the liquid material that the thermowell is exposed to and should provide a degree of corrosion resistance for all surfaces. Usually Type 304 or 316 stainless steel is specified.

### **6.3.7 Thermal Conductivity**

The space between the sensor and the thermowell wall shall be filled with an appropriate amount of heat-conducting material. This will improve heat conduction between the wall of the thermowell and the sensor and improve the temperature sensor response time. Do not use material that will freeze under normal operating and atmospheric conditions.

## **7 PROCEDURES FOR TEMPERATURE DETERMINATION**

### **7.1 Static Temperature Determination Using Liquid-in-Glass Thermometers**

#### **7.1.1 General Information**

For static temperature determination in storage, lease, ship and barge tanks, Table 4 shows the minimum number of temperature measurements that must be taken to calculate an average temperature.

For a non-pressure tank, a temperature may be obtained by lowering an ASTM tank thermometer of appropriate range, and with an appropriate sampling apparatus (e.g., cup-case) through the gauge hatch to the specified liquid level. Keep the thermometer immersed for a predetermined time period, and then quickly withdraw and read the thermometer. This procedure is also used for a low-pressure tank equipped with a gauge hatch or perforated standpipe. It cannot be used for pressurized or inerted tanks fitted with vapor control valves.

For a tank equipped with a thermowell, a temperature is obtained by reading a thermometer placed in the well with its bulb at the desired liquid level.



Table 4 – Minimum Number of Temperature Measurements for Various Depths of Hydrocarbon Liquid in Storage, Lease, Ship and Barge Tanks

| Depth of Liquid                  | Minimum Number of Temperature Measurements | Measurement Level                             |
|----------------------------------|--|---|
| > 6.0 m (20 ft)                  | 3  | Middle of the upper, middle, and lower thirds |
| >3.0 and ≤6.0 m (>10 and ≤20 ft) | 2  | Middle of upper and lower halves              |
| < 3.0 m (10 ft)                  | 1  | Middle of liquid                              |

Notes:

1. For tanks with capacities less than 1590 m<sup>3</sup> (10,000 bbl), and no temperature stratification, one temperature measurement at the middle of the liquid can be used. Also, one temperature measurement at the middle of the liquid will suffice in ship or barge tanks containing less than 1590 m<sup>3</sup> (10,000 bbl).
2. The temperature of a liquid in a storage tank or marine vessel can vary throughout its depth: therefore, when temperature differentials greater than 1 °C (2 °F) are found, an average temperature shall be obtained. This may be accomplished by taking temperatures at different levels that are equally spaced apart, averaging the readings, rounding off the result to the nearest 0.05 °C (0.1 °F), and reporting the result as the average temperature for the entire volume. In some cases, such as when a tank has a non-uniform cross-sectional area, it may be necessary to calculate a volume weighted average temperature.
3. Additional temperature measurements may be taken for higher precision, if agreed to by all parties.
4. The temperature for small crude oil lease tanks should be determined in accordance with the guidelines in API MPMS Chapter 18.1.

#### 7.1.1.1 Tank Temperature Stratification

Temperature differences between the external environment and the tank liquid along with variations in product temperature as the tank is filled are primary causes of stratification. Heat sources internal to the tank may also result in stratification. The degree of temperature stratification is dependent on the duration of the liquid in the tank, the homogeneity of the liquid, the ease with which natural convection or forced circulation results in temperature equilibrium and the temperature differential relative to the environment. Heavy viscous liquids and tank contents formed from a mix of different grades of liquid are more likely to experience temperature stratification. Liquids that are much warmer or colder than the external environment are also more likely to stratify as the ground temperature below the tank is often more moderate than the surrounding environmental temperature. For marine cargo tanks, the temperature in adjacent cargo tanks may also impact stratification. Tank insulation limits the impact of environmental temperature differences but may not completely eliminate it.

Temperatures in large tanks, greater than 1590 m<sup>3</sup> (10,000 bbl), are normally stratified unless the tank contents are thoroughly mixed. In the vertical direction, temperature differences of as much as 3 °C (5 °F) are possible, and differences of 5 °C (9 °F) or more may occur.

Tank temperature stratification can be reduced by tank fill, empty and transfer procedures, the use of pumps and by in-tank mixers.

In the horizontal direction, the temperature differences are typically less than 0.5 °C (1 °F) for low and medium viscosity petroleum liquids. Somewhat higher differences may be expected in high viscosity petroleum liquids and very large diameter tanks.

As shown in Note 2 of Table 4, if the measured temperature differential between temperatures at two successive levels is greater than 1 °C (2 °F), an average temperature shall be obtained. This will require taking additional temperatures at different levels that are equally spaced apart. Additional readings shall be taken until the differential is less than or equal to 1 °C (2 °F). The readings shall then be averaged and rounded to the nearest 0.5 °C (1 °F). This average will be the average temperature for the entire volume.

All tanks with a nominal volume of less than 1590 m<sup>3</sup> (10,000 bbl) are considered to be NOT stratified for the purpose of temperature measurement procedures outlined in this standard unless otherwise agreed by all parties impacted by the measurement.

#### 7.1.1.2 Ambient Temperature Measurement

Tanks undergo expansion and contraction due to variations in ambient and product temperatures. Such expansion or contraction in tank volume may be computed once the tank shell temperature is determined. Tanks that have been calibrated in accordance with API MPMS Ch. 2 have capacity tables based on a specific tank shell temperature. If the observed tank shell temperature differs from the capacity table tank temperature, correct the volumes extracted from the table accordingly. To do this the tank shell temperature shall be determined.

The tank shell temperature for non-insulated tanks is a function of the liquid temperature and the ambient temperature. Since non-insulated storage tanks cannot readily be sheltered from the elements, ambient air temperature has to be considered, in addition to the liquid temperature, when calculating a correction factor to determine the effect of temperature on the steel shell of a tank as required by API MPMS Ch. 12.1.1.

$$Tsh = [(7 \times TL) + Ta] / 8$$

Where:

$Tsh$  = tank shell temperature  
 $TL$  = liquid temperature  
 $Ta$  = ambient temperature

Ambient temperature ( $Ta$ ) is a representative atmospheric temperature in the vicinity of the tank farm. Ambient air temperature surrounding a storage tank is always an arbitrary, and usually a widely varying parameter. Therefore, it is difficult to determine the best place to measure it. For this reason alone, the uncertainty of this measurement can be  $\pm 2.5$  °C (5 °F). However, the ambient temperature component is only 1/8 of the total tank shell temperature ( $Tsh$ ). Therefore the accuracy required for the measurement of the ambient temperature ( $Ta$ ) is not as high as that required for the liquid temperature ( $TL$ ).

The recommended methods of taking this temperature are:

- A temperature device carried by the gauger into the tank area immediately prior to gauging tanks. Take at least one temperature reading in a shaded area. If more than one temperature is taken, average the readings.
- Shaded external thermometers permanently mounted in the tank farm area.

- Local on-site weather stations.

Temperature readings are to be taken at least 1 m (3 ft) from any obstructions or the ground. Additionally, allow sufficient time for the temperature reading to stabilize.

Thermometers used for this purpose shall have an accuracy (maximum permissible error) of 1 °C (2 °F) or better, which should be verified every three months. For reporting purposes, round the ambient temperature to the nearest whole degree.

### 7.1.1.3 Timing of Temperature Measurement

Measure temperatures immediately before or after the liquid level is measured.

### 7.1.1.4 Immersion Times

Stabilize thermometers at the liquid temperature before they are read. To reach stability quickly, accomplish all measurements by continuously raising and lowering the probe approximately 0.3 m (1 ft) above and below the desired temperature measurement depth. Failure to induce movement will substantially increase the required immersion times. Table 5 shows immersion times for liquid-in-glass thermometers. Annex C provides procedures to verify immersion times.

Table 5 – Comparison of Recommended Immersion Times for Woodback Cup–Case Assemblies

| Kg/m <sup>3</sup><br>@ 15°C | API Gravity<br>@ 60 °F | In-Motion  | Stationary |
|-----------------------------|------------------------|------------|------------|
| <780                        | >50                    | 5 min      | 10 minutes |
| 825 to 779                  | 40 to 49               | 5 minutes  | 15 minutes |
| 876 to 824                  | 30 to 39               | 12 minutes | 20 minutes |
| 934 to 875                  | 20 to 29               | 20 minutes | 35 minutes |
| >934                        | <20                    | 35 minutes | 60 minutes |

Notes:

1. These immersion times were established based on the test procedure outlined in Annex C. Failure to use these recommended times may result in incorrect temperature readings.
2. The woodback cup-case assembly can be used in either an in-motion or a stationary mode. In motion is defined as repeatedly raising and lowering the assembly 0.3 m (1 ft) above and below the desired depth.
3. Cup-case assemblies made of other materials will have different immersion times. Immersion times should be established by testing, and all parties involved should agree on the immersion times (see Annex C).
4. If additional mass, such as a weight to cause the woodback cup-case assembly to sink, is placed in the liquid near the thermometer, the immersion time of the assembly will be longer than those listed in this table. Immersion times should be established by testing, and all parties involved should agree on the times (see Annex C).

### 7.1.1.5 Reporting Temperatures

#### 7.1.1.5.1 Single Point Temperatures

Small tanks (less than 1590 m<sup>3</sup> or 10,000 bbl), tanks storing a uniform temperature material, and tanks with adequate mixing equipment have less temperature stratification. Only in these cases would a single-point temperature measurement be acceptable for custody transfer purposes.

#### 7.1.1.5.2 Average Temperatures

When multiple temperatures are taken, the results shall be averaged and rounded to the nearest 0.5 °C (1 °F). This average will be the average temperature for the entire volume. If a tank has a non-uniform cross-sectional area, it may be necessary to calculate a volume weighted average temperature for the volume in the tank.

### 7.1.2 Procedures for Static Temperature Determination in Non or Low Pressure Tanks and Cargo Carriers

#### 7.1.2.1 Stationary Bulk Storage Tanks

The average temperature in a tank of liquid for custody transfer is required to calculate its volume at a standard temperature, so temperature must be determined accurately. During the gauging operation, temperatures shall be taken at the correct measurement level (see Table 4); but before temperature readings are taken, allow the temperature assembly the time necessary for stabilizing at the temperature of the liquid at the measurement level (see Table 5). Read and record temperatures in tanks greater than 1590 m<sup>3</sup> (10,000 bbl) to the nearest half of a thermometer scale graduation (typically 0.25 °C or 0.5 °F) but they may be reported to less than 0.25 °C (0.5 °F) if all parties involved agree and if this does not conflict with legal requirements.

Liquid temperatures in a storage tank often vary significantly with depth. When custody transfer measurements are being performed, collect temperatures at multiple levels to calculate an average temperature.

When the liquid level in a tank of 1590 m<sup>3</sup> (10,000 bbl) or greater is more than 3 m (10 ft), take multiple temperatures depending on the level (see Table 4). If the temperature differential between measurements at successive levels exceeds 1 °C or 2 °F, take and average additional temperatures at different levels that are equally spaced apart.

All measurements shall be recorded, and then averaged. Report the average to the nearest 0.05 °C (0.1 °F).

For liquid levels less than 3 m (10 ft) or for tanks of less than 1590 m<sup>3</sup> (10,000 bbl), use a single measurement at the middle of the liquid with the mutual agreement of all parties.

The cylindrical core of any storage tank will provide the most representative temperature measurement because it is the area least affected by external factors, which may influence the shell of the tank.

Large storage tanks with external floating roofs normally have several gauge hatches around the perimeter of the tank and may have a hatch in the center of the roof area as well. Large fixed roof tanks or tanks with internal floating roofs usually have one or more gauge hatches located around the outer perimeter of the roof. When more accuracy than the conventional method for determining custody transfer or fiscal quality temperature (Upper, Middle, and Lower temperatures from the gauge well or roof hatch close to gauge well) is desired, then the temperatures may be taken in all of the hatches and averaged. Of course, with immersion time requirements for cup-case thermometers, this would require a considerable amount of time; therefore it should be

used in extraordinary circumstances only. At a minimum, temperatures must be taken as close as possible to the gauge hatch.

Smaller crude oil lease tanks usually only have one gauge hatch located near the shell of the tank. Temperature determination in lease tanks shall follow the guidelines in API MPMS Chapter 18.1.

When obtaining temperature measurements through a hatch located near the shell, on small or large tanks, the thermometer assembly shall be suspended at least 0.3 m (1 ft) from the shell of the tank or as far as the hatch will allow. See Tables 4 and 5 for recommended number, depths and immersion times for taking temperatures in lease or storage tanks.

For inventory control, all of the above procedures may not be required. Company procedures should be followed for inventory control. Storage tanks may also have local direct reading thermometers which are discussed in Annex D.

### 7.1.2.2 General Procedures

#### 7.1.2.2.1 Temperature Determination Using Cup-Case Thermometers

To obtain a temperature reading of a tank of less than 1590 m<sup>3</sup> (10,000 bbl) for custody transfer with the cup-case assembly, it shall be lowered through the gauge hatch or pressure lock to the required level and moved gently through a range of  $\pm 0.3$  m (1 ft) of the required level for the time specified in Table 4, which gives the recommended immersion times for the woodback cup-case assembly. For immersion times not covered by Table 5, Annex C provides a procedure for determining them for liquid-in-glass thermometers. As noted in Table 5, the required immersion time for the cup-case assembly may be minimized by continuously raising and lowering the assembly. To take a reading, withdraw the assembly and read the thermometer with the cup sheltered below the edge of the hatch to minimize the possibility of a change in the reading due to wind or atmospheric temperature. Keep the cup full at all times while the thermometer is being read, and record the temperature immediately. For operational expediency and the ability to determine and verify temperature stratification in tanks of 1590 m<sup>3</sup> (10,000 bbl) or more, a portable electronic thermometer will provide significant improvements in response time.

#### 7.1.2.2.2 Temperature Determination Using Armored-Case Thermometers

The armored-case assembly is normally not used for custody transfer temperature determination in low or non-pressurized bulk storage tanks because the temperature indication may change as the assembly is raised out of the tank. It may be used for inventory determination when less accuracy in temperature determination is acceptable.

#### 7.1.2.2.3 Temperature Determination Using Angle-Stem Thermometers

Do not use angle-stem thermometers for temperature determination in custody transfer applications. They may be used for inventory determination when less accurate temperature determination is acceptable.

### 7.1.2.3 Tank Cars and Tank Trucks

Temperatures should be taken on every tank car at the middle of the liquid. However, by mutual agreement, when loading multiple tank cars or with non-heated oil from one source, temperatures may be determined on the contents of at least 10% (a minimum of three tank cars) of the number of cars, selected at random. This assumes that all of the tank cars are of the same nominal size and that all of them are either insulated or all uninsulated. When a car is to be heated to facilitate discharge in cold weather, take the temperature of the contents of each car at the same time the car is gauged. In all cases, thermometer immersion times shall be in accordance with those specified in Table 5.

Before tank cars are loaded with crude oil, determine the temperature of the volume in the heel of the tank car. The heel temperature may be assumed to be at ambient temperature, unless the heel volume exceeds 7% of the tank car capacity. In that case, a temperature needs to be measured in the middle of the heel level. (See API RP 3000.)

This section also applies to the determination of the temperature in tank trucks.

### 7.1.2.4 Marine Vessels (Ships & Barges)

On marine vessels, take temperatures in all tanks or compartments, and measure these temperatures using the measurement information and immersion times provided in Tables 3 and 4. For both ships and barges, determine the average temperature for each tank.

For marine vessels required to operate with closed or restricted systems, do not use liquid-in-glass thermometers. In these circumstances, the vessel will be fitted with vapor control valves, and measurements may only be taken with a suitable portable electronic thermometer (PET) or a portable electronic gauging device (PEGD) with a built-in temperature measurement device. For vessels that do not have closed or restricted systems, the procedure used in bulk storage tanks applies (see Section 7.1.2.2.1).

If there is insufficient [less than 100 mm (4 in)] on-board quantity (OBQ) or remaining on board (ROB) volume to permit temperature measurement or if this material is below its pour point, it may be assumed to be at the standard temperature of 15 °C (60 °F). The temperature of any substantial OBQ or ROB volume shall be taken at the mid-level of the hydrocarbon.

Table 6 shows temperature assemblies and the temperature levels for tanks and cargo carriers.

Table 6 – Thermometer Assemblies and Temperature Levels for Tanks and Cargo Carriers

**Stationary Tanks**

| Thermometer Assemblies | Tank                                | Typical Temperature Measurement Location | Measurement Levels | Use       |
|------------------------|-------------------------------------|--|--------------------|-----------|
| Cup-case               | Fixed Roof                          | Roof Hatch                               | See Note 1         | Custody   |
| Cup-case               | Floating Roof                       | Gauge Hatch                              | See Note 1         | Custody   |
| Cup-case               | Variable Vapor Space                | Gauge Hatch                              | See Note 1         | Custody   |
| Cup-case               | Variable Vapor Space                | Pressure Lock                            | See Note 1         | Custody   |
| Armored                | Variable Vapor Space                | Vertical Thermowells                     | See Note 1         | Custody   |
| Angle Stem             | Variable Vapor Space                | Horizontal Separable Wells               | See Note 2         | Inventory |
| Cup-case               | Horizontal-Cylindrical Non-pressure | Gauge Hatch                              | See Note 1         | Custody   |
| Armored                | Horizontal-Cylindrical Pressure     | Vertical Thermowells                     | See Note 1         | Custody   |
| Angle Stem             | Horizontal-Cylindrical Pressure     | Horizontal Separable Wells               | See Note 3         | Inventory |

**Tank Cars and Tank Trucks**

| Thermometer Assemblies | Tank Cars and Tank Trucks | Typical Temperature Measurement Location | Measurement Levels            | Use     |
|------------------------|---------------------------|--|-------------------------------|---------|
| Cup-case               | Non-pressure              | Dome Hatch                               | Middle of Liquid <sup>4</sup> | Custody |
| Armored                | Pressure                  | Vertical Thermowells                     | Middle of Liquid <sup>4</sup> | Custody |

**Ships and Barges**

| Thermometer Assemblies | Ship and Barge Tank | Typical Temperature Measurement Location | Measurement Levels            | Use     |
|------------------------|---------------------|--|-------------------------------|---------|
| Cup-case               | Non-pressure        | Deck Hatch                               | See Note 1                    | Custody |
| Armored                | Pressure            | Vertical Thermowells                     | Middle of Liquid <sup>4</sup> | Custody |

Notes:

1. See Table 3 for minimum number of levels
2. Three for tank heights less than 10 m (30 ft); four for tank heights greater than 10 m (30 ft)
3. Two, one at middle of tank and one at 0.3 m (1 ft)
4. In special cases, it may be desirable to obtain temperatures at more than one level and calculate a weighted average temperature. See Table 3, Note 2, for the correct method for averaging multiple temperatures.

**7.1.2.5 Horizontal Cylindrical Tanks**

The temperature of the liquid in a horizontal cylindrical tank can vary with depth, just like in a vertical tank. The level at which to measure the temperature depends on the liquid depth as a percentage of the tank diameter. Table 7 shows the recommended temperature measurement level and sampling level for varying levels in the tank. (See API MPMS Ch. 8.1.)

Table 7 – Temperature Measurements for Horizontal Cylindrical Tanks

| Liquid Depth<br>(Percent of Diameter) | Measurement Level<br>(Percent of Diameter Above Bottom) |        |       |
|---------------------------------------|---|--------|-------|
|                                       | Upper   | Middle | Lower |
| 100                                   | 80  | 50     | 20    |
| 90                                    | 75  | 50     | 20    |
| 80                                    | 70  | 50     | 20    |
| 70                                    |   | 50     | 20    |
| 60                                    |   | 50     | 20    |
| 50                                    |   | 40     | 20    |
| 40                                    |   |        | 20    |
| 30                                    |   |        | 15    |
| 20                                    |   |        | 10    |
| 10                                    |   |        | 5     |

### 7.1.3 Procedures for Static Temperature Determination in Pressure Storage Tanks and Cargo Carriers

Temperatures of liquids in pressure tanks and cargo carriers normally cannot be obtained through open hatches. The preferred temperature measurement in these circumstances is use of automatic tank thermometers (ATTs) (or a PET through a vapor control valve if pressure limitations permit). If using thermometers, locate them in suitably located thermowells or separable sockets or through pressure locks. Levels at which temperatures are to be taken are outlined in Tables 4 and 6. If using thermowells, fill the thermowells with a suitable heat transfer medium. Thermowells installed in the vertical wall of a tank or in the curved wall of a cylindrical tank shall be inclined slightly to retain the heat transfer medium.

#### 7.1.3.1 Pressure Locks

A pressure sampling and gauge lock is a vapor-tight assembly mounted on the top of a tank, which can be used for obtaining temperatures. The lock shall have a vapor-tight window and shall enclose a bob and tape on a reel, which can be operated by a handle. A shut-off valve is required between the lock and the tank to prevent vapors from escaping while the lock is open.

When taking temperatures through a pressure lock, a cup-case assembly may be used. It may also be possible to use an armored case thermometer with other sampling apparatus. To obtain the temperatures, the following sequence shall be used:

- a. Wind the tape on the reel until the bob is above the shut-off valve, lock the reel, and close the valve to prevent vapors from escaping from the tank.
- b. Open the window, remove the bob (being careful not to damage the bob), and attach the cup-case assembly to the tape.



- c. After attaching the cup-case assembly, close the window, open the valve, and lower the cup-case assembly to the prescribed level with the reel.
- d. After the proper immersion time has elapsed, withdraw the cup-case assembly from the tank into the pressure lock and immediately read the thermometer through the window. If the thermometer cannot be read through the window, close the valve and open the window to take the reading.
- e. After all of the required temperatures have been obtained, remove the thermometer assembly and replace the bob.

Where pressure limitations permit, the preferred method is to use a closed or restricted system PET through a vapor lock valve.

### 7.1.3.2 Horizontal and Spherical Pressure Tanks

Equip a horizontal-cylindrical pressurized storage tank either with a vertical thermowell that extends through its center to about 150 mm (6 in) from its bottom or with two horizontal separable wells: one in the middle of the tank and one 0.3 m (1 ft) above the bottom of the tank.

Equip a spherical or spheroidal-type tank with either horizontal separable wells or pressure locks which can be used for temperature determinations. If horizontal separable wells or sockets are used, three are sufficient for a tank less than 9 m (30 ft) high: one about 0.6 m (2 ft) above the lower capacity mark and one for each additional 3 m (10 ft) of maximum liquid height. At least four thermowells are necessary for a tank more than 9 m (30 ft) high: one about 0.6 m (2 ft) above the lower capacity mark, one about 1.2 m (4 ft) below the upper capacity mark, and two at about equal intervals between the top and bottom wells.

#### 7.1.3.2.1 Temperature Determination Using Armored-Case Thermometers

The armored-case assembly may be used in pressurized tanks equipped with vertical thermowells that are filled with a suitable heat transfer medium. When armored-case thermometers are used in this application for temperature determination then use the following procedure. For small pressure tanks, lower the thermometer assembly into the well to the middle of the liquid in the tank. For large pressure tanks, lower the thermometer to the level indicated in Table 4. Usually a minimum of 5 minutes is required for the thermometer to reach a stabilized temperature; however, conduct tests on each given application to determine the required immersion time.

To read the temperature, the assembly shall be withdrawn, but the perforated end shall remain in the well to minimize the possibility of a change in the thermometer indication. Read the thermometer, and record the temperature immediately. Failure to withdraw and read the thermometer quickly may result in erroneous readings due to temperature gradients within the tank and ambient temperature affects.

#### 7.1.3.2.2 Temperature Determination Using Angle-Stem Thermometers

Angle-stem thermometers are permanently installed in separable sockets or thermowells and are removed only for replacement or calibration. Other items to remember concerning angle-stem thermometers are:

- a. Ensure that angle-stem thermometers are installed in the same orientation that they were in when they were calibrated.
- b. If a separate graduation scale is used, verify that the etched reference line on the angle-stem thermometer is aligned with the zero on the scale.

### 7.1.3.3 Pressure Tank Cars and Tank Trucks

Equip each pressure tank car and tank truck with a vertical thermowell that extends through the shell to the middle third of the cargo compartment.

### 7.1.3.4 Pressure Marine Vessels (Ships & Barges)

Equip each ship and barge compartment pressurized to greater than 20.7 kPa (3 psig) with an individual vertical thermowell that extends from a point 150 mm (6 in) above the deck to at least the center of the tank.

## 7.2 Dynamic Temperature Determination Using Liquid-in-Glass Thermometers

### 7.2.1 General Information

Dynamic temperature determination includes the measurement of the quantity of liquids flowing through a pipe, as well as the determination of temperature in equipment used for calibrating or proving the measurement of the quantity of liquid moving through a pipe. The temperature devices used for this purpose are generally glass reference thermometers (see Table 3) that conform to the specifications in ASTM E1 or to NMI specifications, or electronic temperature sensors such as resistance temperature detectors (RTDs) or platinum resistance thermometers (PRTs).

The thermometers may be of the partial or total immersion type. Immerse partial immersion thermometers to the proper level as marked on the thermometer. Usage at different immersion depths or at significantly different ambient temperatures from which the thermometer was certified may require that stem corrections be made. Total-immersion thermometers are typically used partially immersed into a thermowell and partial-immersion thermometers are often used with the liquid column not at the level of the top of the thermowell. The emergent liquid column that is outside the thermowell will respond to the ambient temperature. This may cause a significant error in the reading depending upon the difference between the temperature being measured and the ambient temperature, and the amount of active stem that is exposed to the ambient condition. Make corrections where necessary, in accordance with the procedure detailed in Annex B.

### 7.2.2 Temperature Discrimination

Select a liquid-in-glass thermometer to meet the temperature discrimination requirements of API *MPMS* Ch. 12.2, and to higher levels of discrimination if practical. For example, if the thermometer used has a graduation interval of 0.1 °C or 0.2 °F, then the temperature shall be read and reported to 0.05 °C or 0.1 °F.

### 7.2.3 Dynamic Temperature Determination

For all dynamic temperature measurement applications using liquid-in-glass thermometers, refer to API *MPMS* Ch. 7.4 for guidance. This includes, but is not limited to, quantity transactions, metering, meter proving, prover calibrations, and density measurement.

## 8 INSPECTION, VERIFICATION, AND CALIBRATION REQUIREMENTS

### 8.1 Inspection

#### 8.1.1 General

Prior to using a liquid-in-glass thermometer assure that the glass is not broken or cracked, that the liquid column has not separated or degraded and that all markings are legible.

- a. A broken/cracked thermometer shall be taken out of service and disposed of properly.
- b. Replace the thermometer if the scale graduations or other markings are not legible after cleaning. Distinct markings for a thermometer properly chosen for clear or opaque liquids reduce the likelihood of erroneous temperature readings.
- c. Never use a thermometer with a separated liquid column. It may be possible to reconnect a separated column. Seek guidance from the thermometer vendor for an appropriate method. If the liquid column has been completely rejoined, the thermometer may be used provided it is found by bench inspection (as described in Section 8.1.1) to be accurate within the limits of Tables 2 or 3.

#### 8.1.2 New and Recalibrated Thermometers

Newly purchased calibrated thermometers and those that are received after offsite calibration shall be verified at a single point as described in 8.2.2 in addition to the inspections detailed above. Newly purchased non-calibrated thermometers should be verified at a minimum of three points as described in Section 8.2.3.

#### 8.1.3 Cleaning

Thermometers require periodic cleaning to avoid the formation of an insulating film of residual product, particularly after use in heavy or high-pour-point oils, and to ensure legibility of markings. An armored-case thermometer is particularly susceptible to the formation of an insulating film. Frequently remove the glass thermometer from the metal assembly and clean. Most typical petroleum solvents and soaps are suitable for cleaning. Test for compatibility with thermometer markings prior to establishing a cleaning procedure using new cleaning agents or for a new supply of thermometers.

## 8.2 Verification

### 8.2.1 Tolerances

The recommended verification tolerances between an operating thermometer and a reference thermometer are shown in Table 1. A difference in excess of the tolerance indicates that corrective action is required in the form of calibration or replacement of the inaccurate thermometer. These limits may be subject to other guidelines existing in agreements, contracts, regulations, or company policy. Table 1 is provided as a reference for tolerances considered acceptable for static and dynamic temperature determinations in custody transfer measurement of petroleum and petroleum products.

### 8.2.2 Single-point Verification

Single-point verifications, as the name implies, are comparisons made between a thermometer and another temperature measuring device that acts as a reference. The reference device shall be an NMI traceable test device of suitable resolution and accuracy. Normally the single point is either at ice point, current operating temperature, or ambient temperature, although it may be any appropriate temperature within the functional range of the thermometer.

Single-point verifications at ice point make use of an ice-point bath (See 8.2.6). Operating temperature verifications involve insertion of the thermometer and the reference device in the liquid whose temperature is being measured. For dynamic measurement, a test well is used. Ambient temperature verifications typically are performed in a container of water into which the thermometer and reference device are both placed.

### 8.2.3 Multipoint Verification

A multipoint verification establishes whether a thermometer is reading within specification throughout its scale. Compare the thermometer to a NMI traceable test device of suitable resolution and accuracy. The comparison shall be made at three or more temperatures to ensure that the thermometer is accurate within the limits given in Tables 2 or 3. Typically, the checkpoints are approximately 10 %, 50 % and 90 % of the temperature range in which the thermometer is expected to be used. (See NIST Special Publication 1088 for additional details on verifications.)

Note: ASTM E1 and E2251 specify specific temperatures for the calibration of the full operating range of each specific thermometer, but for use in the petroleum industry a calibration as specified above covering the expected operating range of the thermometer is acceptable.

### 8.2.4 Prior-to-use Verification

Thermometers that are used for intermittent service, such as tank gauging, shall be verified before each use or once per day, whichever is less frequent, against a NMI traceable test device of suitable resolution and accuracy at a single point, such as ambient temperature, or in a temperature-controlled source (e.g., temperature bath).

## **8.2.5 Periodic Verification**

### **8.2.5.1 Continuous Service Thermometers**

Periodically verify thermometers that are in continuous service while on line, against temperature devices in the system and against a NMI traceable test device. The frequency of verification will vary depending on system throughput, attended or unattended operation, and other operational or regulatory factors. Quarterly verification of accuracy should be a minimum requirement (i.e., the maximum length of time between verifications). More frequent checks are recommended (e.g., during every meter proving).

### **8.2.5.2 Mercury-in-Glass Thermometers**

For mercury-in-glass thermometers that were previously calibrated, an annual single-point verification, such as at the ice point, provides a reliable indication of the gradual relaxation in the glass and provides a means for the accurate adjustment of the remainder of the scale. However, if the verification shows changes that are larger than the thermometer accuracy (see Tables 2 and 3), then a recalibration or thermometer replacement is required.

### **8.2.5.3 Liquid-in-Glass Thermometers**

As liquid-in-glass thermometers with organic liquids require annual calibrations, no additional verifications are required other than as specified in 8.2.4.

## **8.2.6 Ice-point Bath Preparation**

An ice-point verification must be performed using a properly prepared ice-point bath. The ice used, should be made from distilled or de-ionized water, or it can be the clear portion of commercially available ice, which is frozen from the outside inward. Shave or crush the ice into small pieces and place into an insulated container (preferably a Dewar vessel). Put as much ice as possible into the vessel as possible and fill the voids with distilled water to form a slush, but not enough to float the ice. Cover the surface with an opaque cover and allow to stand for 15 min to 30 min. As the ice melts, drain off some of the water and add more ice to replace that which has melted. The ice point is ready to use when it has set for 15 min to 30 min, the ice should be saturated with distilled water, but the ice should not float in the vessel, and there is no excess water on the surface of the ice. (See ASTM E77 and NIST Special Publication 1088 for additional information.)

## **8.3 Calibration**

### **8.3.1 General**

All temperature measuring devices used for custody transfer shall be calibrated against a reference standard traceable to an NMI.

Glass thermometers having scale graduation intervals of 0.1 °C or 0.2 °C or 0.1 °F or 0.2 °F shall be supplied with a calibration certificate that details corrections which are to

be applied to observed readings. For thermometers with scale graduations greater than above, the need for a calibration certificate is at the discretion of the user.

### **8.3.2 Mercury-in-Glass Tank Thermometers**

Mercury-in-glass thermometers used below temperatures of 200 °C (392 °F) require only one complete multi-point calibration in their lifetime. An annual ice-point verification in accordance with 8.2.2 is all that is required.

### **8.3.3 Low-Hazard Liquid-in-Glass Tank Thermometers**

Liquid-in-glass thermometers with organic liquids require at least a three point calibration each year.

### **8.3.4 Reference Thermometers**

Reference thermometers shall be verified annually as per Section 8.2.2 at the ice-point and only recalibrated if out of tolerance.

### **8.3.5 Calibration Documentation or Certificates**

The results of all thermometer calibrations shall be documented. This may take the form of a calibration report or a certificate.

- a. Upon completion of the calibration process, the party which performed the calibration shall furnish a calibration report including at a minimum:
  - i. An indication that the thermometer has met or exceeded the specifications and tolerances for its intended use
  - ii. The serial number or unique identifier for the thermometer being calibrated
  - iii. The date of the calibration
  - iv. The entity and individual performing the calibration
  - v. The calibration points
  - vi. The serial number or unique identifier for the reference equipment used in the calibration
- b. A calibration certificate is provided by an independent party and serves as a record of traceability and conformance to a specified calibration procedure. The certificate may act as a summary sheet with the addition of a separate calibration report or may be inclusive of all documentation requirements. At a minimum certification documentation shall include:
  - i. The requirements listed above for a calibration report

- ii. The necessary information to verify the traceability of the reference device(s) used
- iii. The procedure used
- iv. Calibration results (calibration points and associated measured errors)
- v. The measurement uncertainty associated with the calibration results
- vi. The expiration date of the certification

If a calibrated thermometer is not immediately placed into service, but rather stored in a protected environment, the required calibration intervals do not start until the thermometer is placed into service. The date of initial service shall be properly documented and an inspection performed in accordance with 8.1.2 at that time.

### **8.3.6 Calibration Correction Factors**

The outcome of a calibration may be a set of scale corrections at discrete temperatures within the range of the thermometer or a correction function.

In virtually all cases where a glass thermometer is being used for dynamic temperature determination, it will be necessary to calculate a correction to the reading of the thermometer to compensate for *in situ* conditions of its immersion depth as well as for effects from the ambient temperature. This process is discussed in detail, with step-by-step instructions and examples, in Annex B. The application of corrections from the calibration report is also discussed in Annex B. After all corrections are made the reported temperature shall then be designated as the corrected temperature.

## **Annex A (Informative)**

### **Mercury-in-Glass Thermometer Alternative Testing Phase I – Tank Measurement**

#### **A.1 Project Objective**

Mercury-in-glass thermometers (MIGTs) are used in the temperature determination of petroleum products in various applications. Due to the potential hazards in handling mercury, MIGTs are being phased out of use. The National Institute of Standards and Technology has stopped calibrating MIGTs and several states in the USA have banned the sale of MIGTs. Due to their history of use and reliability, MIGTs have been considered the preferred method for the temperature measurement of petroleum products in the oil and gas industry.

API, in collaboration with the U.S. Environmental Protection Agency, conducted a comparison study of MIGTs to other liquid-in-glass and digital thermometers in order to provide a comparison of the accuracies of each type of device and thus be able to specify alternatives to MIGTs with confidence for the measurement of temperature of petroleum product in static tanks.

#### **A.2 Testing Protocol**

Testing was done in six geographical regions of the US with MIGTs, low-hazard liquid-in-glass thermometers, and portable electronic thermometers (PETs). The glass thermometers were installed in cup-case assemblies. Data was collected from tanks containing five different products each falling within the API gravity at 60 °F classifications in Table 3 of this chapter.

Three readings per tank were obtained with each instrument repeated for three days (with the same operator at each geographical location) at a minimum of six geographical locations. Each reading consisted of an upper, middle, lower and averaged temperature reading. Readings were taken as close together as possible for each tank. Each alternative temperature device was used individually and simultaneously at the same depth with the certified mercury-in-glass ASTM thermometer.

#### **A.3 Geographical Regions**

The testing took place in the following geographical regions: Northeast USA, Southeast USA, Midwest USA, Gulf Coast USA, Southwest Coast USA, and Northwest Coast USA.

#### **A.4 Results of Testing**

There was no statistically observable difference between the low-hazard liquid-in-glass thermometer results and the MIGT results relative to the reporting resolution of 0.5 °F.



There was no statistically observable difference in the PET results relative to the reporting resolution of 0.1 °F, except for API Gravities greater than 50 °API and less than 20 °API. There was up to a -0.05 °F bias possible for °API >50 and <20.

The bias on the PET was likely due to the PET being read in-situ at each tank level, while the glass thermometers were pulled to the top of the tank to be read.

Based on this testing, the low-hazard liquid-in-glass thermometers are acceptable alternatives to MIGTs for temperature determination in static tanks.

#### **A.5 Further Information**

To review all of the data obtained during this testing, contact the Standards Department at API.

Ballot Draft

## Annex B (Normative)

### Emergent-Stem Correction for Liquid-in-Glass Thermometers

#### B.1 General

Precision thermometers are designed and calibrated for either *partial immersion* or for *total immersion*. If optimal, accurate temperature measurements are to be obtained, it is imperative that the user understand which type of thermometer being used, and how it is designed to be used.

#### B.2 Identifying Thermometer Immersion Type

##### B.2.1 Partial Immersion

A partial immersion thermometer will typically have three very distinct characteristics to enable its identification. First, there will be an inscription on the back of the thermometer stating how the thermometer should be immersed. This will typically read **76 mm Imm** or **3" Imm** or some variation, stating the required immersion depth. Second, the lower portion of the thermometer, typically several inches, corresponding with the dimension specified, will not have any scale graduations or numbers. Third, there will be an engraved 'ring', or immersion mark, permanently marked on the thermometer stem, indicating how deep the thermometer should be immersed into the medium whose temperature is being measured.

##### B.2.2 Total Immersion

A total immersion thermometer will not have any of the above three identifying characteristics. Instead, it is common to see graduations beginning about an inch or so above the bulb, and consuming the majority of the length of the thermometer. There may or may not be an inscription stating 'Total Immersion'. Some manufacturers label their thermometers; others do not. In the absence of any marking indicating how the thermometer should be immersed, and lacking the characteristics identifying a partial immersion thermometer, the user may assume that the thermometer is designed for total immersion unless indicated otherwise on the associated certificate.

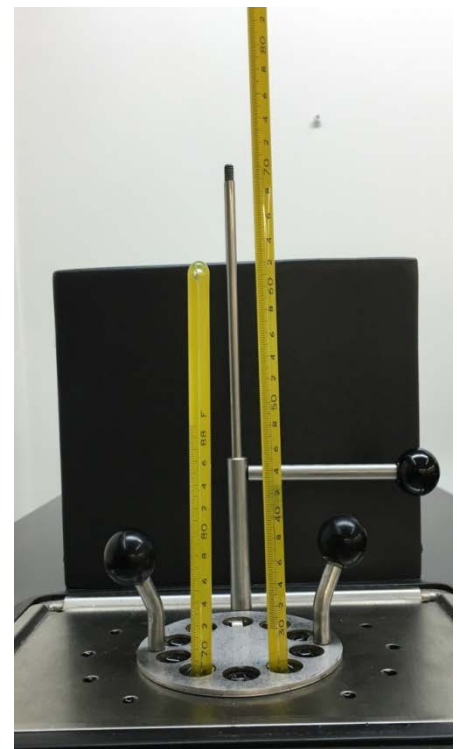

Figure B-1 - Thermometers Immersed in Bath

## B.3 Thermometer in Use

### B.3.1 Partial Immersion

The thermometer should be immersed to the indicated depth, which should be marked by the immersion ring. The immersion depth remains constant despite changes in temperature of the medium being measured. The thermometer on the right in Figure B-1 is a partial immersion thermometer immersed correctly in a bath at 70 °F.

### B.3.2 Total Immersion

The term ‘total immersion’ is something of a misnomer, leading one to think that the entire thermometer has to be immersed, but not so. A total immersion thermometer is designed so that the bulb and all of the liquid - up to the point just below where the liquid meniscus resides - is exposed to the temperature being measured. The thermometer on the left in Figure B-1 is a total immersion thermometer. To measure accurately, the thermometer needs to be immersed so that the 70 °F graduation on the thermometer is just (about ½ inch or so) above the surface of the water, as shown. The idea is that all the liquid inside the thermometer is exposed to the temperature being measured.

## B.4 Examples of Stem Corrections

### B.4.1 Total Immersion Thermometer

A total immersion thermometer is often immersed in a thermowell, as in Figure B-2. The thermometer cannot be “properly” immersed; the thermowell is only a few inches deep. The thermometer is reading 74.2 °F. Complicating the issue, the ambient temperature is 44 °F, which will further affect the reading.

What can be done?

Compensation can be made for the incorrect immersion and the cold ambient air and its effect on the thermometer reading.

The corrected temperature,  $T_c$ , is calculated using the following equation:

$$T_c = T + kn(T-t) \quad \text{Equation B-1}$$

Where:

$T$  = thermometer reading

$k$  = thermal expansion coefficient

*For mercury-in-glass thermometers graduated in °C,  $k = 0.00016$*

*For mercury-in-glass thermometers graduated in °F,  $k = 0.00009$*

*For ASTM E2251 low-hazard liquid thermometers in °C,  $k=0.00079$*

*For ASTM E2251 low-hazard liquid thermometers in °F,  $k=0.00044$*

*These values for  $k$  are to be used unless the thermometer manufacture provides different values.*



**Figure B-2 - Total Immersion Thermometer Partially Immersed in a Thermowell**

$n$  = the number of scale degrees between the point of immersion and the meniscus

$t$  = average temperature of emergent liquid column (the liquid in the thermometer above the point of immersion)

To determine  $n$ , look at the thermometer. It is immersed to about the 26 °F mark. Its reading is 74.2, so  $n = 74.2 - 26$ , or  $n = 48.2$ .

The value of  $k$  is given above.

The value  $t$  requires a measurement of the ambient air temperature immediately around the emergent liquid column. This can be accomplished with a secondary, inexpensive, 'pocket' type thermometer, clipped alongside the precision thermometer. The thermometer should be accurate to  $\pm 2$  °F. A clip can easily be made with two wooden clothespins and two small cable ties, as shown in Figure B-3, to clip the thermometers together.

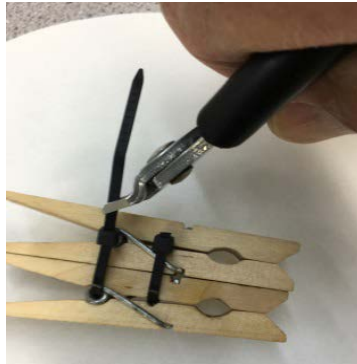

**Figure B-3 - Clip to Suspend Ambient Temperature Thermometer**

Clip the pocket thermometer onto the precision thermometer so that the bulb of the pocket thermometer is located approximately halfway between the immersion point and the meniscus, (near the 50 °F graduation in this example), as shown in Figure B-4.

Measure the average temperature of the emergent liquid column,  $t$ , as 44 °F.

Solve for  $T_c$ :

$$T_c = T + kn(T-t)$$

$$T_c = 74.2 + (.00009 \times 48.2) \times (74.2-44)$$

$$T_c = 74.2 + (.004338) \times (30.2)$$

$$T_c = 74.2 + 0.1310076$$

$$T_c = 74.331076$$

Apply any correction from the calibration report to  $T_c$  (unrounded) and then report  $T_c$  to the resolution of the thermometer (1/2 graduation).



**Figure B-4 - Measuring Temperature of the Emergent Liquid Column**

## B.4.2 Partial Immersion Thermometers Used in 2.5” or 4” Thermowells

Partial immersion thermometers used for dynamic temperature determination are typically designed and calibrated for 3 inches (76 mm) of immersion and are typically immersed in a thermowell.

If the thermowell has a bore depth of 2.5 to 4 inches, the error resulting from incorrect immersion is going to be negligible and can probably be disregarded.

It is necessary to measure the emergent column temperature and run a calculation to compensate for ambient temperature and its impact on the measurement result.

The corrected temperature,  $T_c$ , is calculated using the following equation:

$$T_c = T + kn(t_s - t_o) \quad \text{Equation B-2}$$

Where:

$T$  = observed temperature (reading of the precision thermometer)

$n$  = the number of degrees from the immersion mark to the top of the liquid column. The ungraduated length between the immersion mark and the first graduation on the scale must be evaluated in terms of scale degrees and included.

$k$  = thermal expansion coefficient

*For mercury-in-glass thermometers graduated in °C,  $k = 0.00016$*

*For mercury-in-glass thermometers graduated in °F,  $k = 0.00009$*

*For ASTM E2251 low-hazard liquid thermometers in °C,  $k=0.00079$*

*For ASTM E2251 low-hazard liquid thermometers in °F,  $k=0.00044$*

*These values for  $k$  are to be used unless the thermometer manufacture provides different values.*

$t_o$  = average temperature of emergent liquid column (the liquid in the thermometer above the point of immersion)

$t_s$  = the temperature of the emergent liquid column measured when the thermometer was calibrated (see calibration report)

Determining  $n$  is a very different calculation than that used for total immersion thermometers.

If using a partial (3 inch) immersion thermometer graduated from +30 °F to 124 °F. See Figure B-5. With the thermometer out of the thermowell, use a metric (mm) ruler to measure the distance from the immersion ring to the scale graduation at 30 °F. In Figure B-5, the measurement is 34 mm. Now look at Figure B-6. Place the 0 line of the ruler at the 30 °F mark on the thermometer. Follow the ruler up to 34 mm. The temperature scale value corresponding to the 34 mm line is 37 °F. So, the equivalent in degrees from the immersion ring to the 30 °F mark is 7 degrees. Write that down.

Now place the thermometer into the thermowell and permit it to equilibrate. Note the reading. Suppose the reading of the precision thermometer,  $T$ , is 64.1 °F.

Then,  $n$  = the “degrees” of ungraduated space from the immersion ring to the first scale graduation, plus the value, in degrees, from the beginning of the thermometer scale to the point of reading. So  $n$  = (measured) 7 plus (degrees between 30 and 64.1), so  $n$  = 7 + 34.1, or  $n$  = 41.1.



**Figure B-5 - Measuring Between Immersion Ring and Start of Temperature Scale (34 mm)**

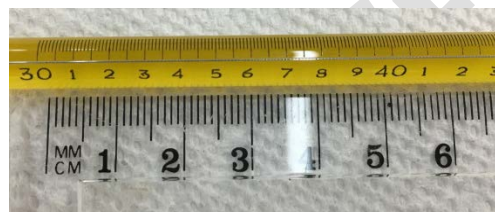

**Figure B-6 - Determining How Many Degrees on the Thermometer Scale Corresponds to 34 mm (7 degrees)**

The value of  $k$  is given above.

The value  $t_0$  requires a measurement of the ambient air temperature immediately around the emergent liquid column, as explained above in Figure B-4. Look at the illustrations. Clip the pocket thermometer onto the precision thermometer so that the bulb of the pocket thermometer is located approximately halfway in between the top of the thermowell and the thermometer meniscus, (near the 44 °F graduation in this example).

Measure the average temperature of the emergent liquid column,  $t_0$ , (for example 80 °F).

If  $t_s$  is 73 °F in this example, solve for  $T_c$ .

$$T_c = T + kn(t_s - t_0)$$

$$T_c = 64.1 + (.00009 \times 41.1) \times (73 - 80)$$

$$T_c = 64.1 + (.003699) \times (-7)$$

$$T_c = 64.1 + (-0.025893)$$

$$T_c = 64.074107$$

Apply any correction from the calibration report to  $T_c$  (unrounded) and then report  $T_c$  to the resolution of the thermometer (1/2 graduation).

### B.4.3 Partial Immersion Thermometers Used in Deeper Thermowells

Deeper thermowells are common, and product temperatures and ambient temperatures can vary widely. When a partial immersion glass thermometer is immersed much deeper than its designated immersion, it becomes necessary to

correct both for the 'too-deep' immersion and for any effects from the ambient temperature on the portion of the liquid column which is exposed. Equation B-3 is derived from Equations B-1 and B-2:

$$T_c = T + kn_1(t_s - T) + kn_2(t_s - t_o) \quad \text{Equation B-3}$$

Where:

$T$  = observed temperature (reading of the precision thermometer)

$n_1$  = the number of degrees from the immersion mark to the top of the thermowell. The ungraduated length between the immersion mark and the first graduation on the scale must be evaluated in terms of scale degrees and included.

$n_2$  = the number of degrees from the top of the thermowell to the top of the liquid column.

$k$  = thermal expansion coefficient

*For mercury-in-glass thermometers graduated in °C,  $k = 0.00016$*

*For mercury-in-glass thermometers graduated in °F,  $k = 0.00009$*

*For ASTM E2251 low-hazard liquid thermometers in °C,  $k = 0.00079$*

*For ASTM E2251 low-hazard liquid thermometers in °F,  $k = 0.00044$*

*These values for  $k$  are to be used unless the thermometer manufacture provides different values.*

$t_o$  = average temperature of emergent liquid column (the liquid in the thermometer above the point of immersion)

$t_s$  = the temperature of the emergent liquid column measured when the thermometer was calibrated (see calibration report)

Below are two very different measurement examples and how to work the equation. (Assume using the same +30 °F to 124 °F thermometer as used to measure above, 3 inch immersion, graduated in 0.1 °F divisions.)

#### **B.4.3.1 Scenario 1 - Hot Ambient Temperature**

The thermometer is immersed into the thermowell up to the 60 °F mark and the thermometer is reading 85.1 °F. The pocket thermometer is clipped so that its bulb is about halfway between the thermowell and the 85.1 °F reading.

$T = 85.1$  °F

$n_1 = 37$  (60-30+7)

$n_2 =$  between 60 and 85.1, so 25.1

$k = 0.00009$  (from above)

$t_s =$  emergent column temperature given on the calibration report for a test point near 85 °F. In the absence of this information, use 75 °F.

$t_o = 90$  °F the temperature of the emergent liquid column. See Figure B-4.

Solve for  $T_c$ :

$$T_c = T + kn_1(t_s - T) + kn_2(t_s - t_o)$$

$$T_c = 85.1 + ((0.00009 \times 37) \times (75 - 85.1)) + ((0.00009 \times 25.1) \times (75 - 90))$$

$$T_c = 85.1 + ((0.00333) \times (-10.1)) + ((0.002259) \times (-15))$$

$$T_c = 85.1 + (-0.033633) + (-0.033885)$$

$$T_c = 85.1 + -0.067518$$

$$T_c = 85.032482$$

Apply any correction from the calibration report to  $T_c$  (unrounded) and then report  $T_c$  to the resolution of the thermometer (1/2 graduation).

#### B.4.3.2 Scenario 2 - Cold Ambient Temperature

The thermometer is immersed into the thermowell up to the 46° mark. The thermometer is reading 55.6 °F. The pocket thermometer is positioned so that its bulb is about halfway between the thermowell and the 55.6 °F reading.

$$T = 55.6 \text{ °F}$$

$$n_1 = 23 (46 - 30 + 7)$$

$$n_2 = \text{between } 46 \text{ and } 55.6, \text{ so } 10.6$$

$$k = 0.00009 \text{ (from above)}$$

$t_s$  = emergent column temperature given on the calibration report for a test point near 55 °F. In the absence of this information, use 75 °F.

$t_o$  = 40 °F the temperature of the emergent liquid column. See Figure B-4.

Solve for  $T_c$ :

$$T_c = T + kn_1(t_s - T) + kn_2(t_s - t_o)$$

$$T_c = 55.6 + ((0.00009 \times 23) \times (75 - 40)) + ((0.00009 \times 25.1) \times (75 - 40))$$

$$T_c = 55.6 + ((0.00207) \times 19.4) + ((0.0002259) \times 35)$$

$$T_c = 55.6 + (0.040158) + (0.079065)$$

$$T_c = 55.6 + 0.119223$$

$$T_c = 55.719223$$

Apply any correction from the calibration report to  $T_c$  (unrounded) and then report  $T_c$  to the resolution of the thermometer (1/2 graduation).

Equations B-1 and B-2 are from ASTM E77. Equation B-3 is derived from Equations B-1 and B-2.



## **Annex C (Normative)**

### **Test Procedure for Determining Immersion Times of Liquid-in-Glass Tank Thermometers and their Assemblies**

#### **C.1 Equipment**

The following equipment is needed to conduct the test procedure described in this annex:

- a. One insulated, temperature-controlled bath with a capacity of approximately 114 L (30 gal).
- b. One NIST-traceable glass thermometer or an equivalent of traceable accuracy.
- c. One portable electronic thermometer.
- d. Two liquid-in-glass tank thermometers and their assemblies (for example, woodback cup-case assembly).

#### **C.2 Test Temperatures**

All tests start with the glass thermometers in their assemblies stabilized at ice point. Suggested bath temperatures at which immersion times should be measured are provided in Table C-1.

#### **C.3 Before the Tests**

- C.3.1** Remove glass thermometers from their assemblies and verify against a NMI-certified thermometer or an equivalent of traceable accuracy. Make verifications at the approximate average test-bath temperature and at temperatures that are approximately  $\pm 30\%$  of the average. Only thermometers that agree within  $\pm 0.3$  °C (0.5 °F) of each test point can be used. Two thermometers are needed to obtain duplicate readings at each test-bath temperature.
- C.3.2** If a portable electronic thermometer is used to determine test-bath temperatures, it is to be verified according to C.3.1.

#### **C.4 Test Procedure**

- C.4.1** Determine the test-bath temperature by measuring it with a portable electronic thermometer, a certified glass-stem thermometer, or a glass-stem thermometer of known accuracy. Suspend this thermometer at all times in the bath at the same level as the test assembly.
- C.4.2** Stabilize the test bath at the lowest temperature as determined by Table C-1. The bath is not to be stirred, circulated, or heated while data is being taken. For densities (API gravities) less than or equal to  $900 \text{ Kg/m}^3$  (greater than or equal to 25 °API), the bath temperature shall be within  $\pm 0.3$  °C (0.5 °F) of the desired test temperature at the start of the test. For densities (API gravities) greater than  $900 \text{ Kg/m}^3$  (less than 25 °API), the

bath temperature shall be within  $\pm 5\%$  of the selected test temperature at the start of the test. Stabilize the tank thermometers in their assemblies at ice point.

Table C-1—Suggested Bath Temperatures

| Kg/m <sup>3</sup> at 15 °C | API Gravity at 60 °F | Test Bath Temperatures <sup>a</sup>  |
|----------------------------|----------------------|--|
| ≤900                       | ≥25                  | 7 °C, 16 °C, 27 °C, 38 °C, 49 °C<br>(45 °F, 60 °F, 80 °F, 100 °F, 120 °F)                      |
| >900                       | <25                  | Average handling temperature $\pm 15$ °C (25 °F) for a total of three test points <sup>b</sup> |

a. Take care not to approach or exceed the flash point of the test medium.  
 b. The temperature  $\pm 15$  °C (25 °F) may need to be adjusted to accommodate the pour and flash points. It shall be adjusted to obtain the maximum differential for obtaining three test temperatures.

- C.4.3** Take care during the test runs not to have direct air movement across the bath from open windows or air conditioning ducts.
- C.4.4** Totally submerge the tank thermometers and their assemblies in the test bath using a string. At the intervals specified in Table C-2, raise and read the thermometers one at a time. The maximum time allowed for reading a thermometer is not to exceed 15 seconds in a test medium less than or equal to 900 Kg/m<sup>3</sup> (greater than or equal to 25 °API) and 30 seconds in a test medium greater than 900 Kg/m<sup>3</sup> (less than 25 °API). Readings are to be taken until three consecutive readings that agree within  $\pm 0.3$  °C (0.5 °F) of the bath temperature as determined with the certified or verified glass thermometers or portable electronic thermometer are obtained with each thermometer. Record all readings to the nearest 0.5 °C (1.0 °F).

Table C-2—Time Intervals for Reading Thermometers

| Kg/m <sup>3</sup> at 15 °C | API Gravity at 60°F | Assembly   | Reading Interval (minutes) |
|----------------------------|---------------------|------------|----------------------------|
| ≤900                       | ≥25                 | In-motion  | 2                          |
|                            |                     | Stationary | 2                          |
| 935 to 905                 | 20 to 24            | In-motion  | 2                          |
|                            |                     | Stationary | 5                          |
| 985 to 940                 | 12 to 19            | In-motion  | 2                          |
|                            |                     | Stationary | 10                         |
| >985                       | <12                 | In-motion  | <sup>a</sup>               |
|                            |                     | Stationary | <sup>a</sup>               |

a. Tests should be conducted to determine acceptable intervals.

Note: Reading intervals are inclusive of reading times which are a maximum of 15 seconds in mediums less than 900 Kg/m<sup>3</sup> (greater than or equal to 25 °API) and 30 seconds in mediums greater than 900 Kg/m<sup>3</sup> (less than 25 °API).

- C.4.5** In the stationary assembly test, create as little disturbance in the test bath as possible when withdrawing and reading the thermometers. For the in-motion assembly test, move the assembly up and down a minimum distance of 150 mm (6 in), ten times per

minute. Take readings for both the stationary and the in-motion assembly tests with the assembly completely withdrawn from the test medium.

**C.4.6** Repeat C.4.1 through C.4.5 for each of the next higher test-bath temperatures as determined by Table C-1 until results are available for all test temperatures. Note that for each higher temperature; stabilize the thermometer assemblies at ice point before the test run is commenced.

**C.4.7** The time taken for each tank thermometer assembly to reach thermal equilibrium with the test bath shall be recorded for each successive test-bath temperature/density (API gravity) combination, and establish the necessary time interval to be used in actual practice.

Ballot Draft

## Annex D (Informative)

### Local Direct-Reading Thermometers

#### D.1 General

Most above ground bulk storage tanks are equipped with at least one local direct-reading thermometer mounted in a fixed thermowell. This local thermometer is not recommended for custody transfer temperature determination because it is usually inaccurate and it does not provide an average tank temperature unless the tank contents are at a uniform temperature. Rather, it provides a rough check on the custody transfer temperature measurement, but may be used for inventory determination.

Table D -1 describes thermowells and location for tank temperature measurement.

Table D -1 — Tank Appurtenances for Temperature Measurement

| Tank Type                                     | Fixed Temperature Measurement  | Portable Temperature Measurement       |
|---|--|--|
| Fixed-roof tanks                              | Thermowell for local thermometer<br>Thermowell for remote readout<br>Thermowells or vertical temperature well for average temperature assemblies | Roof hatch                             |
| Floating-roof or internal floating-roof tanks | Thermowell for local thermometer<br>Thermometer for remote readout<br>Vertical temperature well for average temperature assemblies               | Gauging hatch and slotted gauging well |

#### D.2 Thermowells for Local Reading Thermometers

Extend the thermowell for the fixed direct-reading thermometer through the tank shell for at least 0.3 m (1 ft). A longer immersion depth (0.6 to 0.9 m or 2 to 3 ft) will reduce errors caused by the effect of the ambient air temperature on the liquid immediately adjacent to the tank shell. Ensure the compatibility between the thermowell material and the liquid. Usually Type 304 or 316 stainless steel is specified.

Locate the thermowell and the thermometer for convenient reading near the stairway, ladder, or ATG. Locate the thermowell approximately 0.9 to 1.2 m (3 to 4 ft) above grade for ease of reading and to lessen bottom effects. However, the thermowell shall be low enough to clear the landed roof of a floating-roof or pan-roof tank.

A thermowell fill fluid will reduce the thermometer response time to react to temperature changes. Ensure the fill fluids have a low volatility and freeze point. If the thermowell is sloped down from the horizontal, it will retain the fill fluid better; however, thermowells designed for the angle-stem, industrial-type glass thermometers shall be horizontal.

### **D.3 Local Direct-Reading Thermometers**

#### **D.3.1 Angle-Stem, Industrial-Type Glass Thermometers**

Install angle-stem, industrial-type glass thermometers in standard metal separable thermowells in the tank. The glass stem of the thermometer shall be at least 0.3 m (1 ft) long and shall be protected with a light metal tube. The sensitive portion of the thermometer shall not exceed 60 mm (2.5 in). The assembly graduated scale is acceptable provided that the markings on the scale are permanently attached to the well by a threaded coupling. A thermometer with a separate engraved and the markings are etched on the glass stem of the thermometer, near the ends of the range, to coincide with the corresponding lines on the scale.

#### **D.3.2 Bimetal-Actuated Dial Thermometers**

Install bimetal-actuated dial thermometers in standard metal separable thermowells sloping downward into the tank. The stem of the thermometer shall be at least 0.3 m (1 ft) long, and the sensitive portion of the thermometer shall not exceed 60 mm (2.5 in). Attach the assembly to the well by a threaded coupling.

#### **D.3.3 Mercury-Actuated Dial Thermometers**

Install mercury-actuated dial thermometers in standard metal separable thermowells sloping downward into the tank. The stem of the thermometer shall be at least 0.3 m (1 ft) long. Attach the assembly to the wall with a threaded coupling.

### **D.4 Filled Bulb Systems**

Filled bulb systems consist of a temperature sensor bulb connected via capillary tubing to a pressure sensitive transducer. Three types of filled systems are in common use: Class I, liquid-expansion; Class II, vapor-pressure; and Class III, gas-pressure. System selection depends on application, maintenance philosophy, and temperature range. Exercise care during installation and use to prevent damage (crimping or puncture) to the filled bulb system. Do not use these systems for custody transfer, unless agreed to by all parties involved. They may be used for inventory control.