

Leica Geosystems GS20

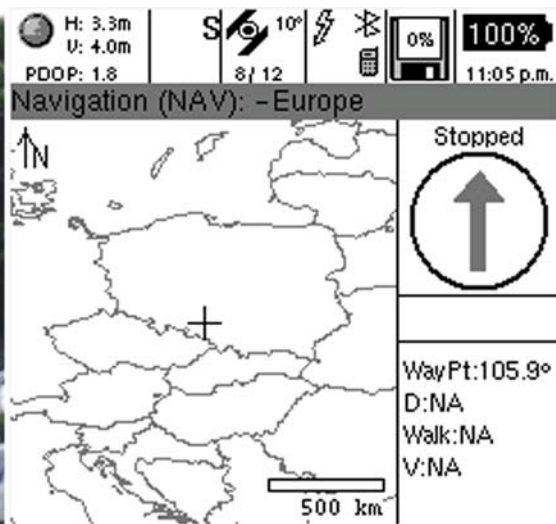

Field Guide

Version 2.0

English

Leica
Geosystems

Leica Geosystems GS20

Congratulations on your purchase of a new Leica Geosystems System GS20.

 To use the product in a permitted manner, please refer to the detailed safety directions in the User Manual.

Symbols Used in This Manual

Symbols used in this manual have the following meanings:

 Important paragraphs which must be adhered to in practice as they enable the product to be used in a technically correct and efficient manner

Tip: *Indicates useful information that may help you execute a task.*

Trademarks

- Windows (registered trademark of Microsoft Corporation)
- Bluetooth (registered trademark of Bluetooth SIG, Inc.)

All other trademarks are the property of their respective owners.

View of chapters

1.	Basic Operation	11
2.	Data Collection	21
3.	Data Management	37
4.	Navigation	45
5.	Job Management	49
6.	Codelist Management	55
7.	Applications	57
8.	Utilities	69
9.	Setup	71
10.	Status	109
11.	Glossary	111
12.	Index	115

Introduction

The Leica Geosystems GS20

The Leica Geosystems GS20 PDM was conceived to provide the GIS community with a GPS data collection device that combines the simplicity of a recreational GPS handheld with the power and flexibility of a professional grade mapping system. The Leica Geosystems GS20 represents a true turnkey GPS/GIS mapping solution by integrating the GPS receiver and antenna within the chassis of handheld data collector. Add to this the built-in efficiency of Bluetooth wireless technology and you have the most efficient GPS / GIS Data Collector in the Market.

Philosophy of Operation

- **Data Collection** is used for the initial recording and attribution of points, lines, and areas.
- **Data Management** is used for the update of attribution and geometry of an object; including relocation and continuation of existing geometry
- **Navigation** is only used for the purpose of finding a known location. Any update to the navigated object must be done in Data Management.
- **Utilities** contains File Browser, Firmware Update and Sensor Transfer
- **Setup** allows the user to configure software operation settings such as GPS controls, Data Collection Quality Control, Interfaces, Units and Formats, and Languages.
- **Status** provides the user with information related to GPS, external interfaces and the condition of the hardware and software.

Table of Contents

1. Basic Operation	11	1.5.4 Tables and Filtering	19
1.1 Batteries and Charging	11	1.5.5 Filtering	19
1.1.1 Battery Status	11	1.5.5.1 Map Filters	19
1.2 Powering On the Unit	12	1.5.5.2 Table Filters	20
1.3 Icons	12	2. Data Collection	21
1.3.1 Accuracy Indicator	12	2.1 Job Management	21
1.3.2 Stop and Go Indicators	13	2.2 Background Files in the GS20	22
1.3.3 Satellite Indicator	13	2.2.1 Overview	22
1.3.4 Differential Corrections	13	2.2.2 Adding Background Files to a GS20 Job ..	22
1.3.5 Memory Card Status	13	2.2.3 Creating a Background File in GIS DataPRO	23
1.3.6 Battery and Time Indicators	13	2.2.4 Transferring a background File	23
1.4 Button Functions	14	2.2.5 Viewing the Map	24
1.4.1 Alpha Numeric Keys	14	2.2.6 Turning off the background in the Map Display	24
1.4.2 Power Key	14	2.2.7 Label Features	25
1.4.3 Enter and Escape	15	2.3 Code Management	25
1.4.4 Cursor Keys	15	2.3.1 Creating Codelists	25
1.4.5 Menu Button	15	2.3.2 Using the Codelist Manager	26
1.4.6 The Main Menu	16	2.3.3 Steps for codelist creation	27
1.4.7 Paging	16	2.3.3.1 Step 1: Creating a new codelist in GIS DataPRO	27
1.5 Software User Interface	17	2.3.3.2 Step 2: Creating Codes in GIS DataPRO ..	28
1.5.1 Map Views	17		
1.5.2 GPS Symbol and Zoom Controls	18		
1.5.3 Context Menus	18		

2.3.3.3	Step 3: Creating Attributes	28	3.2.4.1	Re-Occupying Nodes	40
2.3.3.4	Step 4: Display Attributes: Attaching Map Symbology	29	3.2.4.2	Copying and Pasting Nodes	41
2.3.3.5	Step 5: Transferring Codelists to the GS20	30	3.2.4.3	Inserting, Appending, and Prepending in Existing Lines and Areas	41
2.4	Feature and Attribute Data Collection	30	3.3	Using the Geographic Clipboard	42
2.4.1	Open Job	30	3.3.1	Purpose of the Geographic Clipboard	42
2.4.2	New Job	31	3.3.2	Flow of use (Sharing a common node between blocks)	43
2.4.3	Attribution	32	3.3.3	Creating Point Topology	44
2.4.4	Point Collection	32			
2.4.4.1	Point Offsets	33	4. Navigation		45
2.4.5	Line and Area Collection	34	4.1	The Navigation Screen	46
2.4.6	Modes of Collection	35	4.2	Waypoint Selection and Management	47
2.4.7	Freehand Collection	36	4.3	Creating a New Waypoint Feature	47
3. Data Management.....		37	4.4	Updating a Navigated Feature	48
3.1	Philosophy of Feature Selection	37	5. Job Management.....		49
3.1.1	Options with Nothing Selected	37	5.1	Coordinate Systems	50
3.1.2	Options with a Feature Selected	37	5.1.1	Introduction	50
3.1.3	Options with a Node Selected	38	5.1.2	Overview	51
3.2	Selecting a Feature	38	5.1.3	Attaching a Coordinate System	51
3.2.1	Feature Management	38	5.1.4	Geoid Field File	52
3.2.1.1	Table Filtering	39			
3.2.2	Selecting a Node or “Vertex”	39			
3.2.2.1	Node Management	39			
3.2.3	Feature Table	39			
3.2.4	Node Submenu	40			

6. Codelist Management	55	9. Setup	71
6.1 Creating a New Codelist	55	9.1 Selecting, Modifying and Creating Configurations	71
6.2 Creating a New Code	56	9.1.1 Selecting	72
6.2.1 Creating a New Attribute	56	9.1.2 Modifying	72
7. Applications	57	9.1.3 Setting Password protection for your configuration settings	72
7.1 Cultivated Field Control	57	9.1.4 Creating	73
7.1.1 Introduction	57	9.2 Tree Directory Navigation	73
7.1.2 Setup	57	9.3 Hardware Management	74
7.1.3 Using the Program	59	9.3.1 Hardware	74
7.2 File Conversion	63	9.3.2 Contrast	74
7.2.1 ASCII Conversion	63	9.3.3 Wireless (Bluetooth Connectivity)	74
7.2.1.1 ASCII Import	63	9.3.3.1 Selecting a Wireless Device	75
7.2.1.2 ASCII Export	64	9.3.4 Clearing a Selected Device	75
7.2.1.3 ESRI's Shapefile conversion	65	9.3.5 Real-Time Corrections with a Mobile Phone (RTNet Configuration Set)	75
8. Utilities	69	9.3.6 Linking with the Bluetooth	76
8.1 File Browser	69	9.3.7 Creating a User Defined Configuration Set with an Existing Device	77
8.1.1 Browser Controls	69	9.3.8 Configuring your Device	78
8.1.2 Context Menu	69	9.3.9 Modifying your Configuration	79
8.1.3 Firmware Update	70	9.3.10 Status Indication	79
8.1.4 Sensor Transfer	70	9.3.11 Connecting to the Station	79
8.1.5 Clear System Memory	70	9.3.12 NTRIP	80
		9.3.12.1 An Overview About NTRIP	80

9.3.12.2 NTRIP Client	81	9.8.3 SBAS	93
9.3.12.3 NTRIP Server	81	9.8.3.1 Understanding the SBAS Corrections	94
9.3.12.4 NTRIP Caster	81	9.8.3.2 Changes to the Real-Time Screen	95
9.3.12.5 Using GS20 with NTRIP service	81	9.8.4 Connecting to WoRCS Beacon	95
9.4 ID Template Management	85	9.8.4.1 Powering on the WoRCS	96
9.4.1 Creating an ID Template	85	9.8.4.2 Checking the Bluetooth Link	96
9.4.2 Modifying an Existing Template	86	9.8.4.3 Checking the WoRCS Real-Time Link	97
9.5 Device Manager	86	9.8.4.4 WoRCS Real-Time Beacon	97
9.5.1 Creating a New Device	86	9.8.5 Connecting to WoRCS Real-Time Satellite (RTS)	98
9.5.2 Modifying an Existing Device	86	9.8.5.1 Powering on the WoRCS	99
9.6 GPS Controls	87	9.8.5.2 Checking the Bluetooth Link	100
9.6.1 Tracking	87	9.8.5.3 Checking the WoRCS Real-Time Link	101
9.6.2 Minimum Satellites	87	9.8.5.4 WoRCS RTS	101
9.6.3 Antenna Type	87	9.8.6 Offset Devices	102
9.6.4 Logging	87	9.8.6.1 Configuration of the GS20	102
9.6.5 Initialization	88	9.8.6.2 Overview of the basic methodologies of point offset data collection	104
9.7 Data Collection	88	9.8.6.3 Explanation of individual point offset data collection methodologies	105
9.7.1 Quality Monitor	88	9.8.7 ASCII Input	107
9.8 Interfaces	89	9.9 Units and Formats	108
9.8.1 Real-Time	89	9.9.1 Units of Measure	108
9.8.2 GS20 Phase Wizard	90	9.9.2 Language	108
9.8.2.1 Overview	90	9.9.3 Formats	108
9.8.2.2 Static Phase	91		
9.8.2.3 Kinematic Phase	91		
9.8.2.4 The Interface	91		
9.8.2.5 Collecting Static points, including kinematic points of initialization	92		

10.Status	109
10.1 GPS	109
10.1.1Position	109
10.1.2Satellite Information	109
10.1.3Satellite View	110
10.2 Interfaces	110
10.2.1Real-Time	110
10.2.1.1 RTB Coast Guard Beacon	110
10.3 Hardware	110
11.Glossary	111
12.Index	115

1. Basic Operation

1.1 Batteries and Charging

Leica Geosystems GEB90, 7.2 volt, 2100 mAh Lithium-Ion batteries must be used to power the Leica GS20 and WoRCS equipment. Charge only with the Leica Geosystems battery charger provided in the system.

1.1.1 Battery Status

The Leica Geosystems GEB90 battery uses a microprocessor to accurately monitor the battery status. To adjust the battery microprocessor, allow the Leica Geosystems GS20 to rundown and automatically power off.



Use only the Leica Geosystems batteries, chargers, and accessories, or accessories recommended by Leica Geosystems.

1.2 Powering On the Unit

Press and release the Power Button located on lower left of the keyboard. The unit will reply with an audible tone, then proceed to a splash screen and then to the Main Menu.

 Although the unit can power on without the flash card, most functionality will not be available.

1.3 Icons

The Icon area is displayed to provide the user with current information about the GPS and hardware.

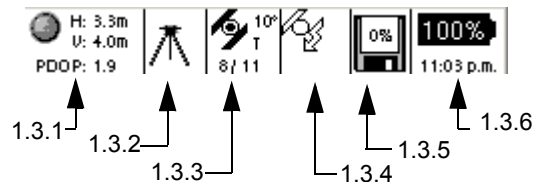

1.3.1 Accuracy Indicator

The accuracy indicator is displayed once a solution is calculated. The open sphere indicates that an autonomous position has been determined and the bullseye target indicates a DGPS solution. Additionally information provided in the text include horizontal and vertical qualities, as well as PDOP.

1.3.2 Stop and Go Indicators

When a static position is located, such as a point or a node (in a line or area), the stop and go indicator is displayed as a tripod. Once the icon returns to the walkingman, the user can proceed to the next collection point.

1.3.3 Satellite Indicator

The satellite indicator provides text based information including the satellite tracking angle, the number of satellites visible (according to the almanac) and the number of satellites currently tracked.

(Satellites Tracked / Satellites Visible)

1.3.4 Differential Corrections

When differential corrections are received and interpreted, the differential icon appears. If the correction is lost after 1/3 of the selected age (see 9.8.1 "Real-Time"), an exclamation point will appear in the lower left hand corner of the window. If it is still absent after 2/3 of the selected age, an additional exclamation mark will appear. If corrections are lost beyond the selected age, a third exclamation will appear and the icon will then disappear.

1.3.5 Memory Card Status

The memory card status icon provides a graphical representation of the percentage of the compact flash used.

1.3.6 Battery and Time Indicators

The battery and time indicators provide information about the current status of the onboard battery and the current time obtained by satellites.

- Because the battery indicator is based on a microprocessor in the Lithium Ion battery, only the onboard battery status can be provided in percentages.
- Because the Leica Geosystems GS20 does not rely on internal batteries for clock function, time is only displayed when 1 or more satellites is tracked.

1.4 Button Functions

1.4.1 Alpha Numeric Keys

Keys 1-9 represent the alpha numeric entry keys of the GS20. Similar to a cellular phone, buttons 2-9 contain alpha characters; by pressing the key continuously, all characters on that key will be scrolled. The selection of a character can be made by either selecting a different key, or waiting for the 2 second time-out. Special characters (.,+,-,*,#,!/?^=\/@") can be found on the decimal key on the lower right of the keyboard.

1.4.2 Power Key

To power the unit on, press and release the power key. The unit will then respond with an audible tone, followed by the splash screen.

 Time to splash screen may depend on compact flash size and the amount of data on disk.

While in operation, the backlight can be turned on with a button press of less than 3 seconds.

If the power key is depressed and held for three seconds, the unit will power down and display a message confirming the power down and saving of data.



 Depressing and holding the key acts like multiple key presses.

Multiple functions: Keys 3 and 9 have been provided with additional functionality. In a map display, 3 and 9 function as zoom keys; in a table, 3 and 9 function as page up and page down.

Table 1-1: Overloaded Button Functions

	Map	Table
3 Down	Zoom In	Page Down
9 Up	Zoom Out	Page Up

1.4.3 Enter and Escape

Similar to standard Windows' controls, the Enter key is used to either accept a choice or advance an action. The Escape key functions both as a back key, to escape from a current screen; as well as a backspace in edit fields.

1.4.4 Cursor Keys

Cursor keys are found on the face and the side of the unit; the side cursors function exactly the same as the up and down cursor on the face. If held down, the cursor key will automatically speed up, such as in the map display, table, or edit field. Because the cursor key is so integral to control and entry, its functions vary in different controls.

1. Menus: Left and Right function as home and end.
2. Edit Fields: Up and Down function as home and end.
3. Check Boxes and Radio Buttons: Left/Right toggle makes a field selection.
4. Combo Box and Spin Controls: Left and Right scroll selections.
5. Map: Controls the cursor

1.4.5 Menu Button

The Menu key is the prime key in the Leica Geosystems GS20 user interface. Not only can Menu bring you quickly back to the Main Menu to load the paging queue and select a new application, it also opens the context menu which contains all of the high level controls for the unit.

1.4.6 The Main Menu

The Main Menu is the base level of the Leica Geosystems GS20 user interface. The Main Menu can be quickly accessed from any application by double clicking the Menu button. By returning to the Main Menu in an open application, it is possible to run several applications simultaneously; this is referred to as the paging function.

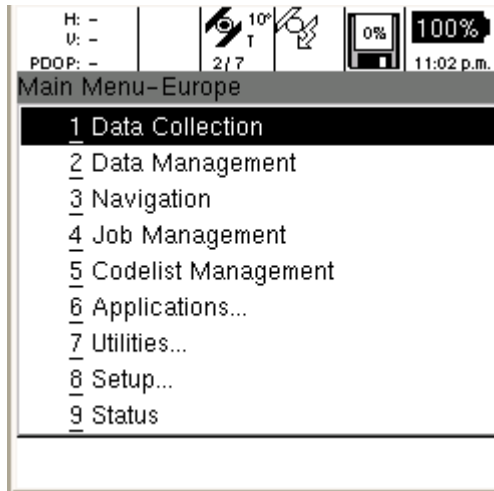

1.4.7 Paging

Because it is often necessary to access several applications at once (e.g. data collection, navigation, satellite view, etc.) Leica Geosystems has created the Power Paging function. Power Paging allows the user to quickly and easily flip through running applications in the order they were opened. To place an application in the paging queue, simply open the application from the Main Menu. To add an additional application to the queue, double click Menu to return to the Main Menu, then open a new application. The paging button will then page through the open applications. To remove an application from the page, simply Escape from the application to the Main Menu.

1.5 Software User Interface

1.5.1 Map Views

The map view is the common interface on which all main applications are built. Data Collection, Data Management and Navigation all contain a map interface that has similar controls and are continuously updated, but have independent settings. Zooms, filtering, selection, and autopan GPS are all unique to each applications mapview.

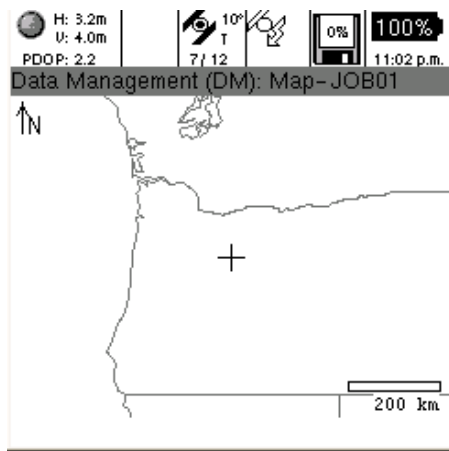

Table 1-2: Mapview Legend

	Points	Lines and Areas
Normal	○	
Selected	●	
Filtered	◉	
Selected Node	■	

Normal: Standard features in Mapview

Selected: The currently active feature selection

Filtered: Display of features in a current table

1.5.2 GPS Symbol and Zoom Controls

By default, an open mapping screen zooms to the full extent of data in a job; however if no data exists, the map will be centered on the GPS location (scaled to 1:20m) awaiting collected data.

The map submenu contains zoom controls for

- Zoom In, Zoom Out, Zoom To Full Extents
- Center Cursor, Center GPS, Center Selected
- Autopan GPS

☞ “3” and “9” function as zoom controls !

☞ The mapview is only capable of displaying 12,000 nodes, being points or line/area vertices. A warning will be issued at 9500 nodes, that the map will be discontinued. A final warning will be issued before the map display is turned off.

Tip: *To minimize nodes in a job; consider streaming lines and areas by distance or at a slower rate. An 8 hour constant collection at a 5 second interval only produces 5760 nodes.*

☞ The map display can be turned off in the Job Management Screen.

1.5.3 Context Menus

The context menu in the Leica Geosystems GS20 functions similarly to a Windows' context menu. However, the right mouse click is replaced with the Menu button. When the Menu button is depressed, a list of choices will be displayed based on the application and the actions taken.



- Choices in the context menu can either be selected using the cursor arrows (Left and Right being home and end) or directly accessed via the number keys.
- To simplify submenus appear where common groupings exist such as map control functions. The submenu is denoted with a right arrow and is accessed via enter or the number key. In some instances, sub-submenus exist.

1.5.4 Tables and Filtering

Tables are used to display multiple attribute data that cannot be directly edited. The table can be navigated by the cursor keys (left and right being home and end) as well as the overload keys **3 Page Down** and **9 Page Up**.

Two main types of tabular data found in the GS20 are selectable and informative.

- **Selectable** fields allow the user to make a selection such as choosing a Job or Codelist, and are usually identified by a radio button (selectable circle). Additional options, such as New, Delete, etc. usually exist in the context menu.

Name	Created
<input type="radio"/> LONGBEACH	02/17/05
<input type="radio"/> CANCUN	02/17/05
<input checked="" type="radio"/> REDONDO	02/17/05

- **Informative** fields allow the user to view and manipulate information about the tabled object.

1.5.5 Filtering

In order to provide power and flexibility to the user, the Leica Geosystems GS20 maintains separate filters for individual tables and maps.

1.5.5.1 Map Filters

Map filters provide the user with the ability to hide or display data in the map.

Map filters allow the user to discriminate data based on

- Feature Code (Layer name)
- Feature Name (Feature ID)
- Feature Type (Point, Line, or Area)
- Time of collection
- Waypoint Status (Flag as Waypoint (i.e. to be navigated to) or Visited)

Similarly data can be filtered in a table for selection, edits, clipboard function or changing the Waypoint status.

1.5.5.2 Table Filters

Table filters allow the user to search for data based upon the same criteria as listed above in map filters.

Once a table is filtered, the user can select from the filtered table, or view the selected filters in the map view via the context menu choice **Table Features**.

 This differs from map filtering in that the data remains displayed, but appears highlighted.

2. Data Collection

2.1 Job Management

When Data Collection is opened, if no job is currently selected, the user will be prompted to either “Open” an existing job or create a “New” job to continue. If a new or empty job is selected, the unit will prompt the user to attach a codelist; otherwise the program will proceed to the Data Collection map.

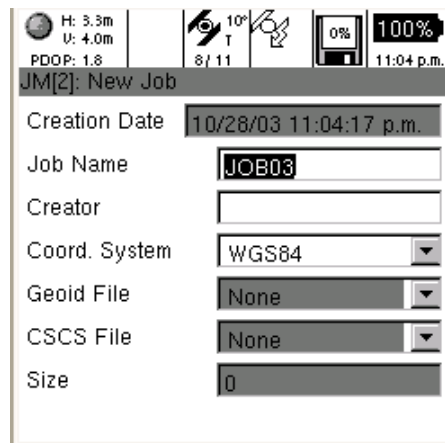
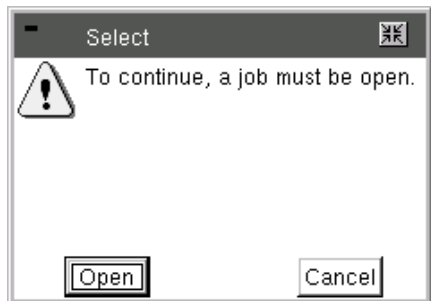

Tip: When you create a new job, you have the option of attaching a Coordinate System and Geoid file with creation of the job.

Tip: See 5. "Job Management" for more info

2.2 Background Files in the GS20

Often it is important for a user to see the location of their current position and those features they have collected within a larger context. However, it is not always necessary or even beneficial to have that data selectable. With the ability to create vector background data, the GS20 can now:

- Attach larger vector reference files
- Use the same vector reference file for multiple jobs
- Reference multiple files to a job
- Reference previously collected jobs in an open job
- Only re-import collected or updated data
- Directly display ESRI shapefiles to navigate in the field

2.2.1 Overview

GS20 background files are graphic files that can be created in GIS DataPRO or from ESRI shapefiles onboard the GS20, and are automatically created when job data is collected in the GS20. The graphic file contains the file extension qtr, which stands for quadtree; a method of spatially indexing vector data. When a job is created in the GS20, a graphic file of that same name is also created. From job management, a background screen can be accessed, allowing the user to reference other “background” graphical data to the job. Background graphic files are for visual reference only, and are not selectable.

2.2.2 Adding Background Files to a GS20 Job

To add a background map, enter Job Management, highlight a selected job, and select “Background Maps” from the context menu.

The 'Main Menu - Europe' screen displays the following options:

- 1 Data Collection
- 2 Data Management
- 3 Navigation
- 4 Job Management
- 5 Codelist Management
- 6 Applications...
- 7 Utilities...
- 8 Setup...
- 9 Status

The 'Job Management (JM) - Jobs - Europe' screen displays the following table:

Name	Created
<input type="radio"/> LONGBEAC	10/28/03
<input type="radio"/> REDONDO	10/28/03
<input type="radio"/> SNDGO	10/28/03
<input checked="" type="radio"/> Europe	10/28/03
<input type="radio"/> areaf	04/23/04
<input type="radio"/> CFCES	04/26/04
<input type="radio"/> CRS	04/21/04
<input type="radio"/> CSR1	04/22/04
<input type="radio"/> JOB01	12/31/00

The context menu over the 'Europe' job displays the following options:

- 1 New
- 2 Open
- 3 Close
- 4 Delete
- 5 Properties
- 6 Map
- 7 Background Maps
- Main Menu

The table below shows job details for 'REDONDO', 'LONG BEAC', 'JOB01', 'areaf', 'CRS', and 'CSR1':

Name	Memory	Status
<input checked="" type="checkbox"/> REDONDO	0.8k	
<input type="checkbox"/> LONG BEAC	0.8k	
<input type="checkbox"/> JOB01	0.8k	
<input checked="" type="checkbox"/> areaf	1.2k	LOADED
<input type="checkbox"/> CRS	1.2k	
<input type="checkbox"/> CSR1	1.5k	

Memory Available: 66396.2k

A status of available memory will be available to provide information on how much information can be attached to a job. Memory used in background files will affect the amount of map data that can be collected, so be conservative in your estimates.

A successful attachment will be shown in the Status column and Memory Available will be recalculated.

2.2.3 Creating a Background File in GIS DataPRO

In order to create a graphic file in GIS DataPRO, it will be necessary to first import the data into the GIS DataPRO database.

Data that is added to GIS DataPRO with the +, or "Add Shapes" cannot be converted into a graphics file.

To create the Graphics file, select "Create GS20 Graphic File" from the Tools pull-down menu.

A dialog will prompt for a filename and path, with the default being active. The user can select to create a background from all data, or only selected objects.

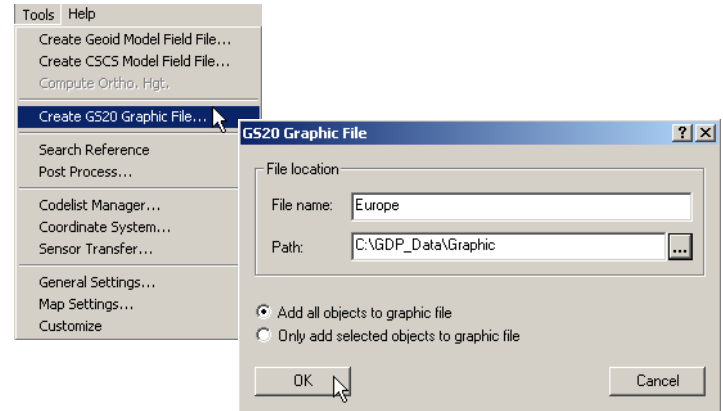

2.2.4 Transferring a background File

To transfer a graphic file from GIS DataPRO to your GS20, select Sensor Transfer from the Tools menu. Right click on Sensors, and select "Add Sensor". Browse through "My Computer" to locate the background graphics file.

Right Click on the Graphic File and send to your connected Device.

2.2.5 Viewing the Map

The background graphic will be attached to the current job, and will be displayed in Map View applications. The memory used by the graphic files is not recovered during use, therefore it is necessary to reboot to reclaim lost space once a background file is detached from a job.

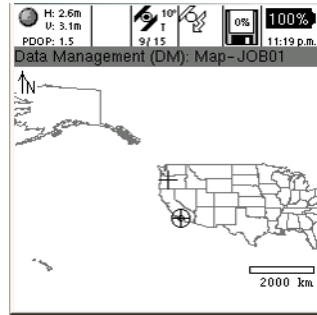
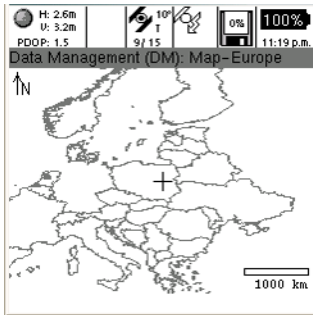

2.2.6 Turning off the background in the Map Display

Similar to the filtering ability of layers and data types in a Map View, Background files can be turned on and off. To turn off a background file, press Menu in Job Management and select Background Maps, and press enter on the layer with the new Background Icon.

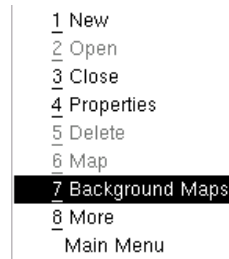

Name	Memory	Status
<input type="checkbox"/> REDONDO	0.8k	
<input type="checkbox"/> LONG BEACH	1.6k	
<input type="checkbox"/> CANCUN	0.8k	
<input checked="" type="checkbox"/> JOB01	34.6k	LOADED
<input type="checkbox"/> JOB02	63.4k	

2.2.7 Label Features

The GS20 provides the ability to label features in a job by name. This capability is available in both the Navigation and Data Management items. To enable press the Menu button, select Map and the check "Show Feature Name".

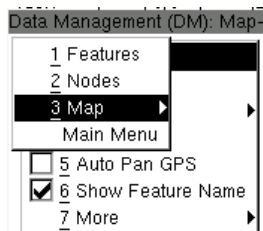
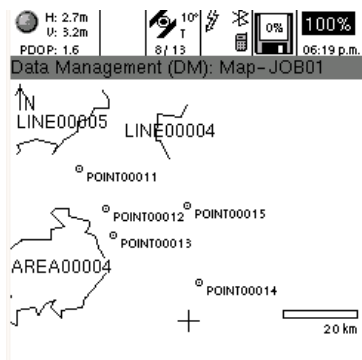

To turn it off, just uncheck this option.

2.3 Code Management

A Codelist contains the coding information that may be defined during measurement in the field. Generally, a Codelist consists of Codes as primary building blocks, and Attributes as tertiary building blocks.

2.3.1 Creating Codelists

What is a Code? Codes are used to describe objects of the same type. The term Code in GIS DataPRO is equivalent to the term theme in ArcView 3.2. Each code has its feature geometry: point, line or polygon. For example: Tree (Point), Roads(Line), Parcels(Polygon).

A code contains attribute information that may be assigned to the codes (points, lines or areas) during measurement in the field.

For example: Fire Hydrant (Code): Serial Number and Color (Attributes).

A Codelist contains codes to be collected in a job, and is attached to a job.

A codelist can be created in three ways:

1. Create your own codelist/code.
2. Copy another codelist/code from another project.
3. Import codes from existing shapefile.

Codelists are created in the Codelist Manager in GIS DataPRO.

2.3.2 Using the Codelist Manager

1. In GIS DataPRO, select Codelist Manager Form from Tools menu.

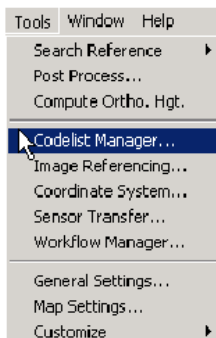

2. The Codelist Manager Interface appears (see following graphic).

The image shows the 'GISDataPRO - [Codelist Manager]' window. On the left is a tree view of codelists: SCCWRP, City, Electric, None, Park, LPA_RRA, Office, CD, Atlanta, and Hydrants. On the right is a table with columns: Codelist, Author, and Modified.

Codelist	Author	Modified
SCCWRP	GPendlet	06-14-01 12:44
City	Jaeson	10-12-99 04:49
Electric	Han	03-11-99 05:10
None	Administrator	01-14-99 08:01
Park	Jaeson	05-05-99 04:24
LPA_RRA	PIERRER	05-10-01 01:09
Office	GPendlet	05-19-01 02:41
CD	CLIFF DE TEMPLE	05-02-01 08:00
Atlanta	GPendlet	06-08-01 09:48
Hydrants	GPendlet	06-01-01 07:52

2.3.3 Steps for codelist creation

1. Create a Codelist in GIS DataPRO
2. Create Codes -
Unlimited codes in a codelist
3. Create Attributes -
Maximum 60 Attributes per code
4. Attach Map Symbology to each code in a codelist
5. Save codelist
6. Transfer a Codelist to sensor.

2.3.3.1 Step 1: Creating a new codelist in GIS DataPRO

1. Click on Codelist and select New Codelist.



2. Type in name of the New Codelist.
3. Click OK.

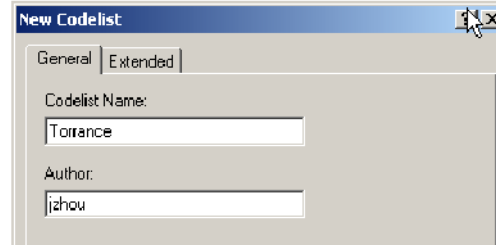

Your new codelist is now created, highlighted and ready to be populated.



When a codelist is created the first code is always Waypoint and cannot be changed!

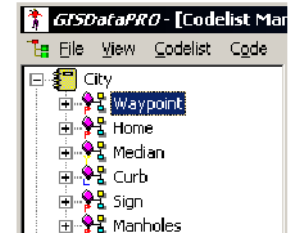

2.3.3.2 Step 2: Creating Codes in GIS DataPRO

1. From the Code menu select New Code.



2. Enter codename, type and description to define new code.

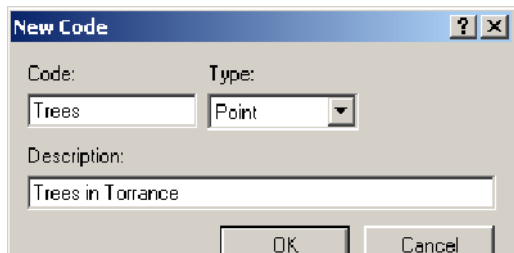

2.3.3.3 Step 3: Creating Attributes

1. From the Attributes menu choose New Attribute



2. Fill in the attribute name and properties.

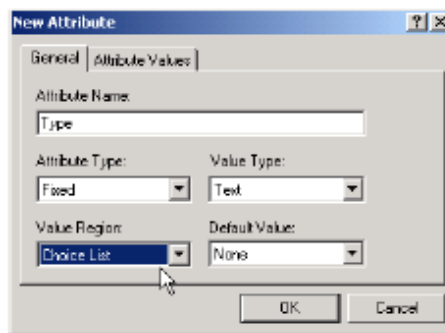

3. The Attribute Type can be Normal, Mandatory or Fixed
4. The attribute's Value Type can be Text, Real or Integer

- The attribute's value region can be None, Choice List or Range

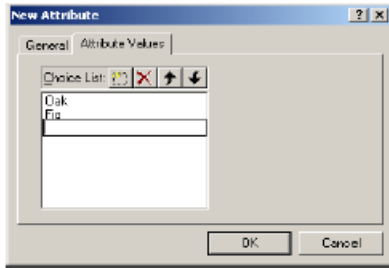

- The Default Value can be typed in if None or Range was selected in the Value region. It can be selected if Choice List was used.

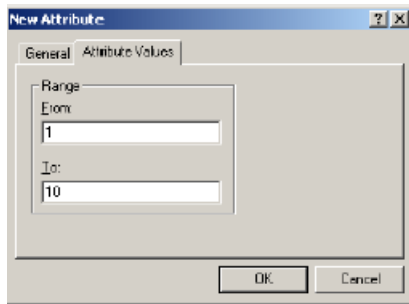

Facts About Attributes:

- The Z attribute is reserved and cannot be changed.
- The Z attribute contains elevation data
- Maximum 256 characters per Choice List
- Attribute names must begin with a letter
- Limit the attribute names to 10 characters
- Maximum 60 Attributes per Code

2.3.3.4 Step 4: Display Attributes: Attaching Map Symbology

The display properties are used to display each feature in the GIS DataPRO after data collection.

From the Code pull down, choose "Set Display Attributes." The Codelist may now be saved with map symbology intact.

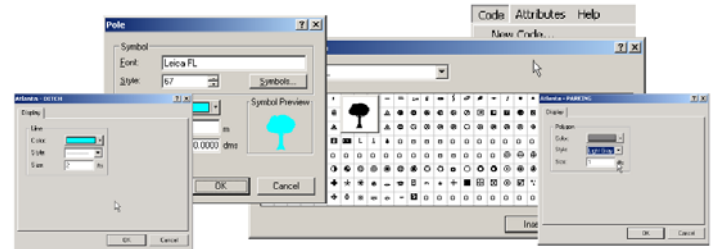

2.3.3.5 Step 5: Transferring Codelists to the GS20

1. Open Sensor Transfer
2. Add Sensor
3. Browse to location where codelists are stored (default location: C:\GDP_Data\Codelists)
4. Right click on codelist and select Send Files...
5. In the Send Files... dialog select the codes you would like transferred
6. Select the appropriate COM port and select Codelist from the File Type Choice

With your codelist now on the GS20, you are ready to attach it to your job and collect GIS Data.

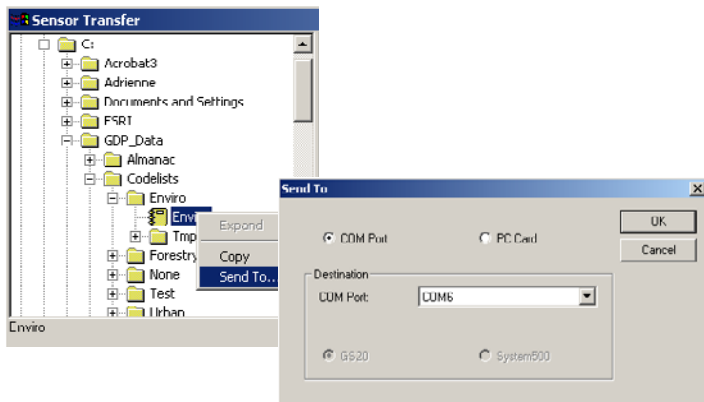

2.4 Feature and Attribute Data Collection

2.4.1 Open Job

To begin feature and attribute data collection, a job must be open. Select **1 Data Collection**.

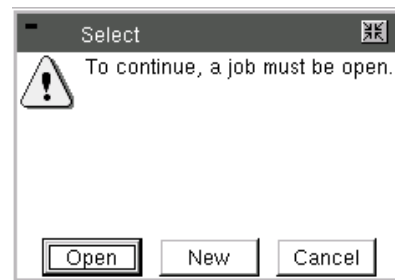

To open an existing job select **Open**. The Job Management screen is displayed.

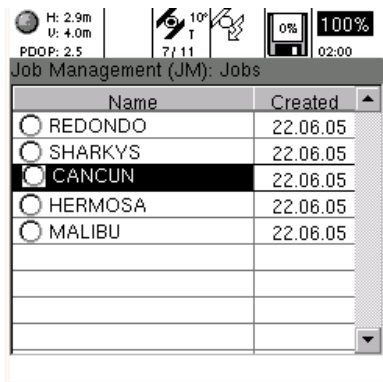

Select an existing job and then press the escape key and return to Data Collection. If the job is not associated with a codelist, choose to open an existing codelist or create a new codelist.

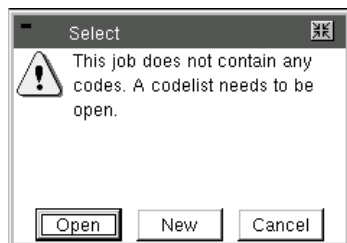

2.4.2 New Job

To create a new job, select **New**. The job Management New Job screen opens.

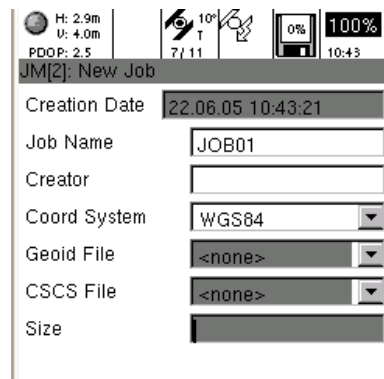

Assign a jobname, creator, coordinate system as well as a Geoid and CSCS file if appropriate. Press the menu button when complete and select Save. A message returns indicating that the job is not associated with a codelist.

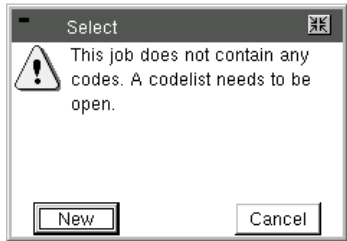

After the codelist is created, if the job does not contain any data, the Data Collection Codes screen is displayed. Select the code for which to begin collecting data and press the Enter key. The feature occupation screen opens.

2.4.3 Attribution

After a code is selected, press Enter to open the feature occupation screen. By using the cursor and Enter key, attribution values can be entered. Additional occupation selections can be accessed via the context menu.

2.4.4 Point Collection

Point collection is often as simple as entering attributes, pressing Occupy and Save; however different user defined quality settings can determine how the feature is collected (see Setup/Data Collection.) In addition to direct locations, the user can also choose from a list of point offsets.

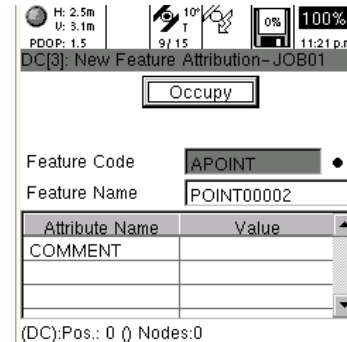

2.4.4.1 Point Offsets

When a point cannot be collected directly, an offset can be used to collect a point from a more accessible location. Offset information can be entered either manually, or via an external rangefinder. The choice of point offsets available are listed below.



Example of Dist.Dist O/S

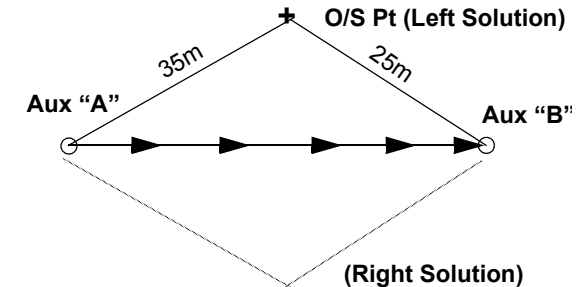
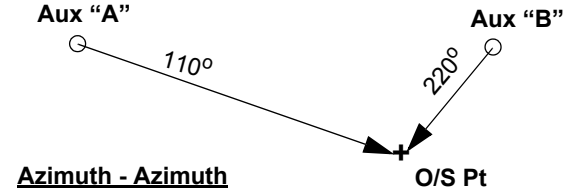
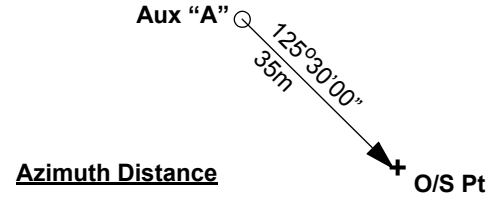
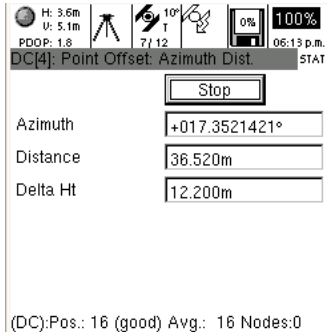

Offset Methods (Graphical)

When collecting a point offset, the offset data must be input prior to the collection of the auxiliary point.

- **Azimuth Distance:** Enter Azimuth, Distance and Delta Height before occupying the point.
- **Azimuth Azimuth:** Enter Azimuth and Delta Ht for 1st position from Aux Pt. A; then repeat for PT B.
- **Distance Distance:** Enter Distance and Delta Ht for 1st position from Aux Pt A; repeat for position B and choose the solution method (i.e. Left or Right)

☞ Because two solutions exist for a double distance intersections, the user must tell the software on what side of point A-B the offset point lies.

- **Backwards Azimuth and Distance:** Useful when locating a point by direct occupation when no GPS exists. This method works by providing an azimuth and distance to a previously located point. The calculation then reverses the course and distance.

2.4.5 Line and Area Collection

Unlike point collection, lines and areas offer multiple methods of collection; noding (i.e. collecting by vertex), streaming by time or distance, locating nodes by point offsets, creating linear offsets to either side of the collected line, pasting a node from the clipboard, and nesting additional features. Because the Start/Stop button is necessary to both stop in noding and pause in streaming, features must be saved by the Done button or the **Save Feature** in the context menu.

Attribute Name	Value
COMMENT	

Tip: When escaping the feature collection, a dialog will allow the user to save or discard the current feature.

2.4.6 Modes of Collection

When a line or area feature is selected, the feature occupation screen displays the current mode of collection (i.e. stream or node.) The last selected mode becomes the default by being stored in the user's recent value file.

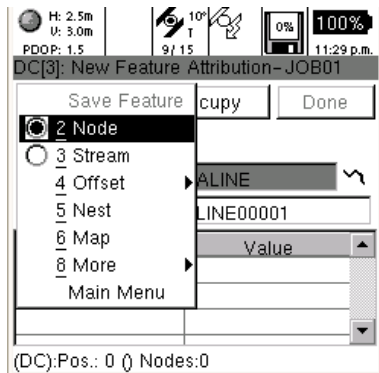

2 Node Mode is the manual collection of nodes or “vertices.” Like points, nodes can be collected using the autostop which can be found in Data Collection\Quality Control settings in the Setup menu.

3 Streaming is the automatic collection of nodes (i.e. vertices) based on time or distance (length between nodes.) Additionally, streaming criteria can be based on the horizontal quality defined in **8 Setup, 1 Config Sets**. Select the proper configuration setting, select Data Collection and Quality Control in the Setup configuration.

Streaming options can be selected from the attribution\collection screen via the context menu.

4 Line Offsets allow the user to enter linear offsets, either left, right or in both directions with different values. *When in node mode*, the offset selection will become a submenu offering all methods of point collection for individual nodes.

The **8 More** selection allows the user to Paste from Clipboard, as well as Append or Prepend an existing line.

Paste from Clipboard allows multiple features to share common nodes. In order to paste a node, it must first be **3 Copied to Clipboard** in Data Management. (See 3.2.4.2 "Copying and Pasting Nodes")

 Point features cannot be created with pasted node data in Data Collection. However, points already collected can have their node replaced with the **2 Paste from Clipboard** function, allowing multiple point features to share a common node.

2.4.7 Freehand Collection

Freehand collection (or digitizing) is an easy way to collect lines, points and polygons without having a GPS position for specific codes. This is very useful if you have to complete attributes but are not receiving GPS position due to heavy canopy. To digitize a feature on the map, select a code in Data Collection, then press the Menu key, select More followed by Freehand Collection. The Map View will open (Key 3 and 9 function as Zoom). Move the cursor to the proper position. Press the Enter key to store the node. For lines and areas press the Escape key after digitizing the feature and confirm by selecting Done.

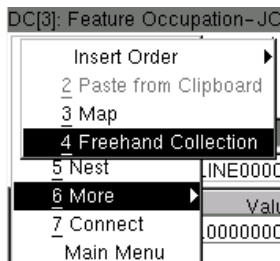

3. Data Management

3.1 Philosophy of Feature Selection

Data Management allows the user to perform feature, node and attribute level data maintenance and editing. Data Management selection options and context menus behave differently depending on what data has been selected. Once a feature is selected, the user must **3 Deselect** via the context menu in order to select another feature. Several levels of selection exist in Data Management.

3.1.1 Options with Nothing Selected

With nothing selected, the user can select features either graphically in the map, tabularly via the **Feature Management** or view and select all nodes in the entire job via **2 Nodes** table.

3.1.2 Options with a Feature Selected

With a feature selected, the user has the ability to:

1. Select from a list of nodes common to the selected feature either graphically in the map or tabularly via the **5 Nodes** table.
2. View or modify the feature's **1 Attribution**.
3. Copy, delete or flag the selected feature as a Waypoints via the **7 More** submenu, or
4. **3 Deselect** the currently selected feature.

3.1.3 Options with a Node Selected

When a node is selected on a feature, the user can select another node common to the feature graphically in the map, view the coordinates or re-occupy the node via **1 Geography**, or use the **2 Node** submenu to:

1. Progress to the First, Last, Previous or Next node.
2. Copy to, Select from, or Paste from a node via the Clipboard.
3. Insert new nodes before or after the current node selected.
4. Delete the selected nodes.

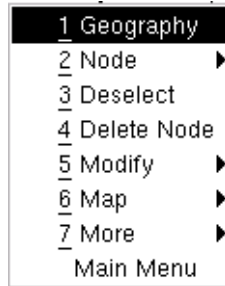

3.2 Selecting a Feature

In order to view or manipulate feature data, a feature must first be selected. Selection can be performed from a table of features via Feature Management, or graphically from a map.

3.2.1 Feature Management

Tabular selection of a feature is done from the **Features Menu**. Initially,

1. Features are listed alphabetically in the Features Menu.
2. Features are grouped by geometry.

However, by choosing Menu and Sort the table can be sorted by Name, Code, Feature Type and by Ascending or Descending order.

- To view the attributes of a table selection, press menu and choose **1 Attribution**, or simply press Enter.
- To select the feature, press Menu and choose **3 Select** from the context menu.

Other operations that can be performed upon a selected feature include feature manipulation (e.g. delete and clipboard functions) and the ability to flag a selected feature as a Waypoint.

Tip: *Linear Perimeter and Polygon area can be calculated in the Attribution screen if a coordinate system has been selected.*

3.2.1.1 Table Filtering

As previously discussed in chapter 1.5.4 "Tables and Filtering", Table Filtering provides a way to search based on:

- Code (Feature Name)
- Feature Type (i.e. Point, Line or Area)
- Code/Feature Name (using wildcards)
- Range of Time
- Waypoint Status

Once data has been filtered, the user can either manipulate or select based on the filtered table, or display the filter in the map using the context menu choice **Tabled Features** and **Highlight**. The **Traverse** submenu choice, allows the user to graphically progress through each filtered table feature row by row.

 Filtered data is shown by a bold outline and can be progressed through using the feature **Next** and **Previous** submenu choice.

3.2.2 Selecting a Node or "Vertex"

3.2.2.1 Node Management

Nodes can be selected from the context menu when nothing is selected, providing a list of all nodes in a job.

3.2.3 Feature Table

When an object is selected at the feature level, the Feature Table provides the user with the ability to

1. See the attribution of a feature, and calculate line lengths or perimeter / area of polygon.
 2. See the nodes of a feature.
 3. Select and highlight it on the mapview.
 4. Delete the selected feature.
-  Leica Geosystems GS20 does not have Undo!
5. Set a database flag indicating the feature is a Waypoint and if it has been visited.
 6. Sort the features either by Name, Code, Type and define the sorting order.
 7. Copy the feature to clipboard.

3.2.4 Node Submenu

When a node or "vertex" of a feature has been selected on a feature the node submenu provides additional node selection ability as well as the ability to modify features on a node level, including:

1. Send the Node to Geography and ReOccupy the node.
2. Choose the **1 First**, **2 Previous**, **3 Next**, or **4 Last** node on a feature.
3. Deselect the feature.
4. Delete the node (you can't delete nodes from a line composed of less than 3 nodes, or from a polygon composed of less than 4 nodes.)
5. Insert single nodes or stream to append to an existing object.
6. Alter the MapView settings.

3.2.4.1 Re-Occupying Nodes

Nodes can be moved or Re-Occupied by choosing **1 Geography** from the menu. When the Re-Occupy soft key is selected the attribution/collection screen is opened.

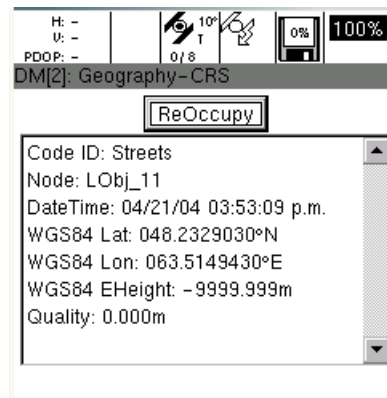

 Node Re-Occupation works in the same way as point collection.

3.2.4.2 Copying and Pasting Nodes

In order to copy a node, a node must first be selected. This can be done directly from a node table, or most commonly on a feature level.

Copying

1. Select the desired feature either graphically or from **Feature Menu Item**.
2. Select a node either graphically or by highlighting a feature from the **Feature table** and selecting **2 Nodes** from the submenu.
3. Select **7 More** and **2 Clipboard**.
4. Select **Copy to**.

Pasting

1. Select the desired feature either graphically or from **Feature Submenu**.
2. Select a node adjacent to the point you wish to insert either graphically or from the **Node** table.
3. Select menu and choose the **2 Node** submenu.
4. In Node table select **Modify**.
5. Select to paste **Before**, **2 After**, or **3 Replace**.

3.2.4.3 Inserting, Appending, and Prepending in Existing Lines and Areas

Previously collected lines and areas can be amended or continued by Inserting, Appending, or Prepending with noded or streamed data.

One of the complexities of adding new data is knowing the order in which a feature was collected. This can be done by using the Previous and Next commands in the Node submenu to discern the direction of collection.

Inserting into a Feature (Node Mode)

1. Select the desired feature to be appended, either graphically or from **Features Item**.
2. Select the feature which includes the node.
3. Select Menu and choose the **2 Node** submenu.
4. Select **5 Modify** and insert **New**.
5. Select **Before** or **2 After**.

Tip: *Because the nature of collection is to continue in the same direction as the collected feature, it is advised to insert After an existing node for multiple nodes or streaming!*

Appending a Line or Area by Streaming

1. To append a line or area by streaming, select the last node of the line and insert **2 After**.
2. In the attribution/collection screen, change the collection mode to stream and occupy as you would with a normal collection.

Prepending a Line or Area by Streaming

Tip: *If you are adding to the beginning of a line by streaming, you will need to reverse the direction of your collection*

1. To prepend a line or area, select the first node and insert **Before**.
2. In the attribution/collection screen, select **6 More**.
3. Select the insertion order **2 Prepend**. This will reverse the direction of collection.

 Advance usage of Prepend and Append can be used to approach the beginning or end of a line from the opposite direction.

3.3 Using the Geographic Clipboard

3.3.1 Purpose of the Geographic Clipboard

Unique to the GS20 is the Geographic Clipboard functionality. The clipboard functionality is similar to the copy and paste functionality found in many Windows styled applications.

This functionality allows the user to select and copy a feature or node to the clipboard, and in turn, the user can paste to or “Select from” the clipboard.

Nodes can be shared between features to create shared edges. For example: Street Intersections and Water Lines can have a node topology that facilitates network analysis. Parcel corners and edges can allow for shared boundaries. Parent / Child Topology of point objects can allow a transformer to be intrinsically tied to a power pole. Thus moving or deleting the parent, would result in the child is also being moved or deleted. By creating this topology in the field, you remove the guesswork from the office.

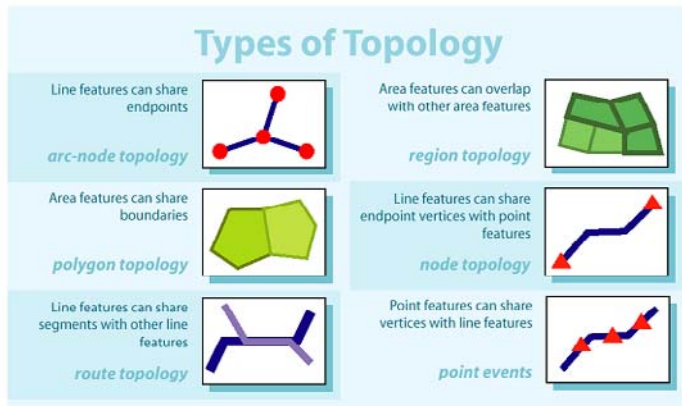

3.3.2 Flow of use (Sharing a common node between blocks)

Select a Feature, and then select a node. If the feature is a point object, you can copy the feature or the node.

1. Open Data Collection
2. Open Data Management, select a feature, and then select a node.
3. Copy the node to the clipboard.

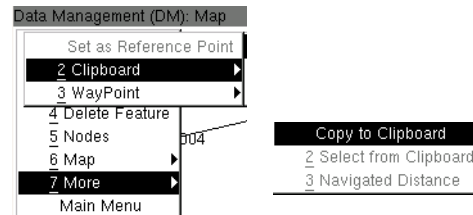

4.  Page to Data Collection.
5. From Data Collection, select New Feature

6. Select More from the menu choices, and Paste the node from the clipboard.

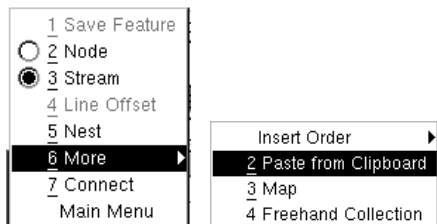

7. Repeat as necessary.

3.3.3 Creating Point Topology

Points features can be linked to other points or nodes by taking advantage of the paste functionality in the Point offset menu. Because the pasted point is the base reference of the newly created feature, when the base is moved or deleted, the connected feature is also modified.

Once a point or node is copied (as shown above), it can be pasted as the Auxiliary or base point in a point offset. This can be done from Azimuth Distance, using the paste function, or is done automatically with Back. Azimuth Dist.

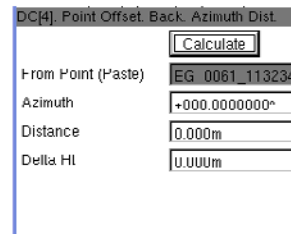
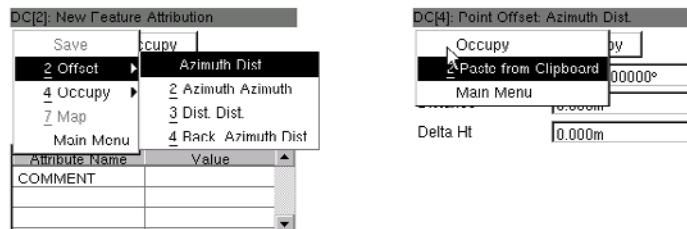

4. Navigation

The Navigation application is a means to guide the user to a point with known coordinate values. In GPS, these known point locations are referred to as "Waypoints". The user also has the option to navigate to points that have never been visited before.

Rather than having a special feature code for "Waypoints," the Leica Geosystems GS20 uses a database flag for the feature to set a Waypoint as:

Flagged: As a feature that should be navigated to
or

Visited: Providing closure to the workflow

Waypoints can be created in the Leica Geosystems GS20 by several methods:

- Select points graphically from the mapview in both Navigation and Data Management.
- Table a known feature and setting the database Waypoint flag in Data Management.
- Set the node on a linear feature as a temporary Waypoint in both Navigation and Data Management.
- Create a new Waypoint by entering known coordinates in Data Management.
- Upload GIS or CAD data set with a Waypoint flag from Leica Geosystems GIS DataPro to the Leica GS20.
- Import points from an ASCII file.

4.1 The Navigation Screen

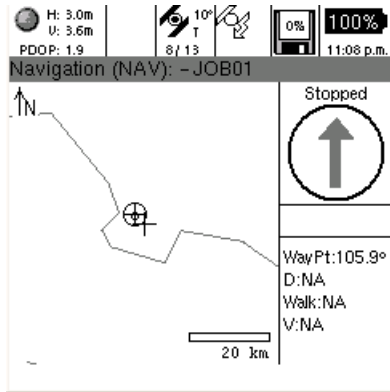

The navigation screen is framed to provide the map display along with active navigational controls and text.

The framed control panel contains a directional guidance arrow, and text fields providing:

1. Azimuth to the Waypoint.
2. Distance to the Waypoint.
3. The user's course Azimuth
4. The user's course Velocity.

➡ Because the GPS bearing and velocity are calculated using GPS positions, the user must be moving for course data to be displayed.

- If the user is stopped, the arrow and course fields will become inactive.
- If the user is moving, but no Waypoint is selected, the arrow becomes a North Compass.

4.2 Waypoint Selection and Management

Similar to Data Management, the Navigation context menu changes depending on whether data is selected.

When features or nodes have not been selected, the context menu provides the user with access to:

1. **Waypoint Management** which provides a list of features or nodes flagged as Waypoints.
2. **Select from Clipboard** if a node was previously copied from Data Management.

If a feature is selected, the context menu then provides **Waypoint** with the options for the feature or node to be:

- **Create New Waypoint Feature.**
- Flag a point as **2 Visited** once it has been navigated to.
- Access back to **1 Waypoints.**

4.3 Creating a New Waypoint Feature

Waypoint features may be created by pressing the Menu key, selecting WayPoint and Create New WayPoint Feature from the navigation screen.

H: 3.0m	U: 3.6m	PDOP: 1.9	10° T	8/13	0%	100%	11:09 p.m.
NAV[2]: WayPoint-JOB01							
Creation Date	12/10/01 07:30:07 a.m.						
Feature Name	<input type="text"/>						
WGS84 Lat	33.8084825°N						
WGS84 Lon	118.3500888°W						
WGS84 EHeight	-16.226m						

This menu allows the user to add a waypoint using WGS84 or Local Grid Coordinate Systems. To access the local coordinate system options, press the Menu key and select local grid. This selection will remain applied until changed by the user.

4.4 Updating a Navigated Feature

Once a Waypoint has successfully been reached, a feature or node can be updated via several methods:

1. Select the Menu key and choose **5 More** and **Copy to Clipboard**.
2. If Data Management is currently open, page to the Data Management application. Otherwise, press the Menu key twice to return to the Main Menu, then Select **2 Data Management**.
3. In Data Management, select the Menu key and choose Nodes, then browse to the Node you want to update and select **6 More**, **2 Clipboard** and **2 Select from Clipboard**. The feature of the node can now be modified as previously discussed in chapter 3. "Data Management".

Tip: Keep both Navigation and Data Management in the paging queue to easily update Waypoints.

5. Job Management

Jobs are created, opened, closed, deleted and modified in Job Management.

1. Creation of a job is performed by pressing the Menu key and selecting **1 New**.
2. Selection and deselection of existing jobs is toggled using the Enter key or choosing **2 Open** or **3 Close** in the context menu.
3. **5 Deleting** is performed via the context menu
4. Viewing or modifying job **4 Properties** must be selected in the context menu
5. Rebuilding, Repairing or Disabling the **6 Map** is performed in the context menu.

 Coordinate systems can be attached to a job after the job is opened.

 A Coordinate System must be attached to a project to calculate perimeter, area or local coordinates.

Coordinate Systems and Codelists are linked to a job, however only the coordinate system is a control in the job properties. The last selected codelist of an open job will be attached to the job.

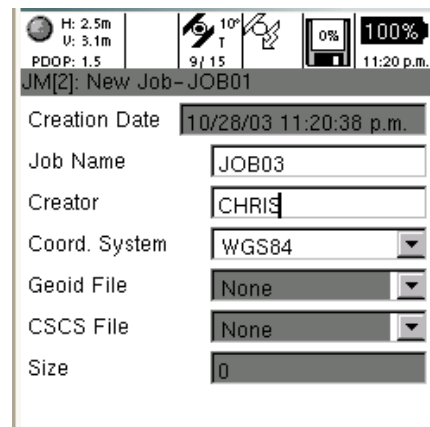

The screenshot shows a dialog box titled "JM[2]: New Job - JOB01". At the top, there is a status bar with various indicators: a globe icon, "H: 2.5m", "V: 3.1m", "PDOP: 1.5", "9/15", "10° T", a hand icon, "0%", and "100%". Below the status bar, the dialog contains the following fields:

Creation Date	10/28/03 11:20:38 p.m.
Job Name	JOB03
Creator	CHRIS
Coord. System	WGS84
Geoid File	None
CSCS File	None
Size	0

 In order to save a new or modified job, it is necessary to select **Save** in the context menu or escape dialog.

5.1 Coordinate Systems

5.1.1 Introduction

Although the GS20 stores all GPS data in a WGS84 geographic coordinate format, it is possible to translate your data into a local datum, projection, or coordinate system. A pre-defined coordinate system is usually made up of

1. An ellipsoid, or a spheroid created to model the earth's surface
 - a. If different from WGS84, a translation is necessary for orientation
2. A Projection - or a means to transform a spherical surface to a 2 dimensional grid
 - a. Cones and Cylinders are the most common forms of projection
3. A transformation - a shifting of the system
 - a. 3 dimensional transformations involve both Cartesian X,Y,Z shift, as well as a rotation and scaling factor
 - b. 2 dimensional transformation usually involve an Euclidean X,Y shift, as well as a rotation, and scaling factor. The Z value, perpendicular to the XY plane can also be shifted.
4. Geoid - an equipotential surface which coincides with mean-sea level, and which may be imagined to extend through the continents. This surface is everywhere perpendicular to the direction of the force of gravity
 - a. The geoid is also an interpolation file, and is based on a grid network of gravity reading. Usually this type of file is local to a geographic region, such as a country or continent.
5. CSCS (Country Specific Coordinate System) - an interpolation file that estimates nonlinear error between known points with both WGS and local coordinate values
 - a. These CSCS can be geographic. Cartesian or local grid in nature. An example of this is the NADCON or North American Datum Conversion.

5.1.2 Overview

When creating a job, it is possible to attach a pre-defined coordinate system, as well as interpolation files for non-linear transformations, and calculations of elevation above mean sea level. It is also possible to re-project a job into a coordinate system of datum at any time in the Job management application.

Coordinate Systems can be created in either GIS DataPRO or Leica Geo Office office software, or downloaded from local websites. Coordinate systems can be transferred via bluetooth, serial cable, or directly onto the compact flash, and are contained in a GPSTRF.dat file.

Although the CSCS and Geoid files are attached to a coordinate system in the office software, it is necessary to make a smaller more localized “Field file” for use in the GPS hardware. These files can then be used in conjunction with the coordinate system on the GS20 to provide transformations, and orthometric height values.

5.1.3 Attaching a Coordinate System

A coordinate system can be attached to a new job upon creation, or to an existing job via the job properties in job Management. In order for a Geoid or CSCS field file to be attached to a selected coordinate system, it is necessary that the system be defined with a Global Geoid or CSCS file attachment. This is done in either DataPRO or Leica Geo Office coordinate system management.

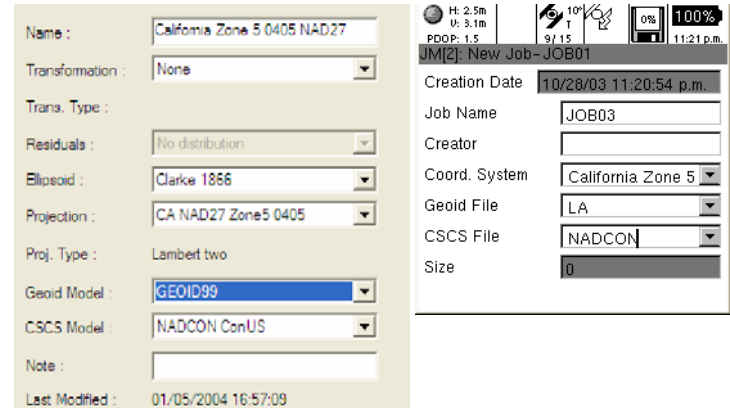

Coordinate System Definition Dialog in GDP

5.1.4 Geoid Field File

Geoid Field File

The field file is a subset of the global interpolation file. A subset is used to reduce the overall memory the file occupies on the hardware.

In this example, the GEOID99 was reduced to a field file called LA to serve the Los Angeles Area. The CSCS was named after the global Field File NADCON (North America Data Conversion). To create a field file in DataPRO or Leica Geo Office, simply select the field file generator from the tools pull-down.

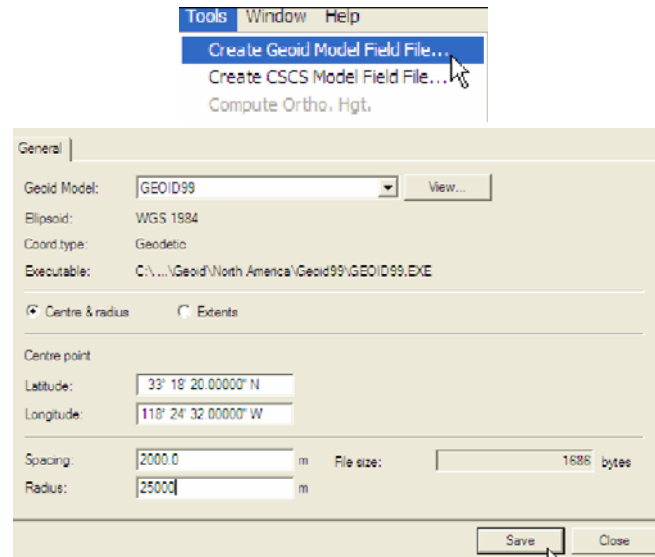

or

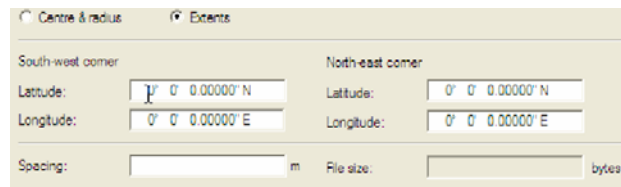

1. To Create a Geoid Field file, choose the Global Geoid file, and then select a center and radius, or South-West and North-East limits can be selected.

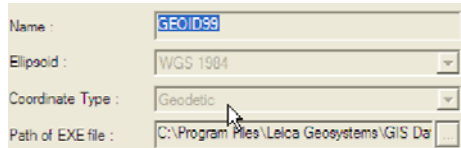

Name : GEOID99
Ellipsoid : WGS 1984
Coordinate Type : Geodetic
Path of EXE file : C:\Program Files\Leica Geosystems\GIS Da

- Geographic or Grid coordinate entry will be determined based on the coordinate type defined in your global geoid file.
 - Pay special attention to the cardinal direction of geographic coordinates
2. Select a spacing for the field file to be interpolated extrapolate to.
 - Geoid99 was created on a grid of 1 arc minute, or roughly 1800 meters. It is probably not necessary to expand or refine this spacing.
 3. Select a Radius if using the Center and Radius method, and Save

 Save the Geoid file to the C:\GDP_Data\Geoid directory for easy transfer using data exchange. CSCS field files work under the same methodology, without the need to choose spacing, and instead save to a path C:\GDP_Data\CSCS.

6. Codelist Management

The Codelist Management application is used to create, select, deselect, delete, and modify codelists. New Codelists, Codes, and Attributes can only be created in the Codelist Manager (i.e. not in the Data Collection codelist).

6.1 Creating a New Codelist

1. Select **5 Codelist Management** from the Main Menu.
2. Press the Menu key and select **1 New**.
3. Enter a unique codelist name or accept the default.
4. A Creator Name can also be entered (Optional).

6.2 Creating a New Code

1. Highlight an existing Codelist, press the Menu key, and select **6 Code Management**.
2. Press the Menu key and select **1 New Code**.
3. Enter a unique code name or accept the default.
4. Select the Code Type (i.e. Point, Line, or Area).
5. A Code Description can also be entered (Optional).

6.2.1 Creating a New Attribute

1. Highlight an existing Codelist, press the Menu key and select **6 Code Management**. (Assuming you are not already in the Code Management screen)
2. Press the Menu key and select **2 New Attribute**. Edit an Attribute Name, otherwise a default will be provided.

Tip: Because of shapefile conventions, Attribute names must start with a letter!

3. Select the Attribute type:
 - Text: All alpha numeric character types
 - Decimal: Real number values
 - Integer: Whole number values

7. Applications

7.1 Cultivated Field Control

7.1.1 Introduction

CFC or Cultivated Field Control is a GS20 application aimed at providing an accurate record of crop quantities and tolerance in accordance with European Union CAP subsidies. A user can collect or select a polygon, and calculate the area with an error estimate corresponding to a user-defined tolerance. Additional functionality also allows the user to subtract areas within the external area, and save the subsequent data to a text log file that can be exported to a personal computer.

CFC is an additional application that requires a keycode file. To purchase the application and receive a keycode, please contact your local Leica representative.

7.1.2 Setup

With the possibility to use a mask file, the application is open to a variety of output into different ASCII file interfaces. The mask file *.MAS is a simple ASCII text file that can be opened in any PC text editor.

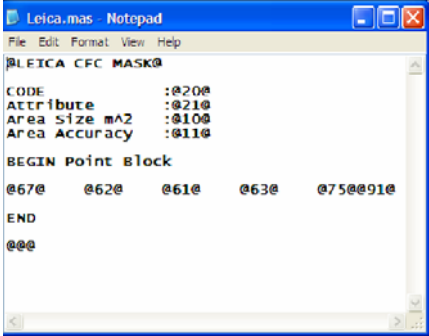

```
Leica.mas - Notepad
File Edit Format View Help
@LEICA CFC MASK@
CODE :@20@
Attribute :@21@
Area size m2 :@10@
Area Accuracy :@11@
BEGIN Point Block
@67@ @62@ @61@ @63@ @75@@91@
END
@@@
```

- The @LEICA CFC MASK@ is the identifier for any mask file.
- The @@@ is the identifier for the end of the mask file.
- A maximum of 15 lines, each capable of containing a maximum of 80 characters, are contained between the beginning and the end identifiers.
- The @00@ until @99@ are placeholders for the numerical values or code/ attribute info. This gives full and easy flexibility to create different output masks for any ASCII type.
- A sample Leica.mas file (right) is provided and can be edited to the needs of the user.

All identifiers are listed below:

Case 00: // new line
Case 01: // @
Case 05: // Active Job-name
Case 06: // Current Date
Case 07: // Current Time
Case 09: // Number of excluded areas
Case 10: // Area Size [m²]
Case 11: // Area Accuracy [m²]
Case 12: // Perimeter [m]
Case 13: // EC Tolerance [m²]
Case 14: // EC Tolerance [%]
Case 15: // Area Id
Case 16: // lower Boundary [m²]/ upper boundary [m²]
Case 17: // lower Boundary [m²]
Case 18: // upper boundary [m²]
Case 20: // Area Code
Case 21: // Attribute
...
Case 40: // Area Attribute Value 1-20
Case 41: // Area Code Note
Case 60: // point id
Case 61: // north(*)
Case 62: // east(*)
Case 63: // height [m]

Case 64: // height type (Orthometric/Ellipsoidal)
Case 65: // geoid height [m]
Case 66: // Point Date
Case 67: // Point Time
Case 71: // CQ North [m]
Case 72: // CQ East [m]
Case 73: // CQ Hgt [m]
Case 74: // CQ Pos [m]
Case 75: // CQ 3D [m]
Case 80: // iterator, starts with 1 for first point of each area point block.
Case 99: // end of point block, only necessary to divide point block from footer lines.

(*) north and east are displayed with 3 digits in meter [m]. If no coordinate system definition is available it is displayed as 360 degree decimal with 9 digits.

The *.MAS file should be placed in the Data/Apps/CFC directory of the GS20 compact flash. A LOG file name defined by the user will be output to this directory as well.

7.1.3 Using the Program

Cultivated Field Control within the applications menu. If a job is not yet opened, the workflow will request that you open or create a job. Once in the CFC main screen, the user will be required to:

- Select the Area for calculation (Mandatory)
- Select any internal areas to be subtracted from the calculation (Optional)
- Select a mask file (Mandatory to save a log file)
- Provide the name of the Log file to be saved.
- Select a tolerance or error limit for the calculation.

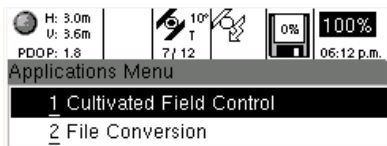

The main Cultivated Field Control menu provides the ability to:

- Select a feature for which to calculate area
- Select interior features to exclude from the calculations
- Choose a mask file to properly format the output file
- Enter the name of the output or "LOG" file
- Enter the tolerance or error of calculation

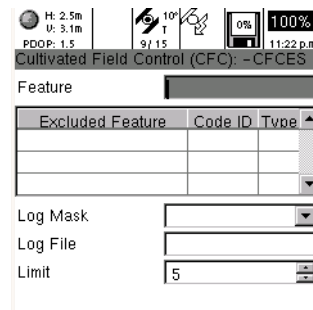

To Select a feature, place the cursor in the feature box and press the Menu key. Areas can also be calculated from this menu.

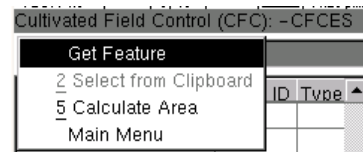

An area can be selected from the table by highlighting the area and pressing enter.

An area may also be selected by copying it to the clipboard from a map or table display in Data Management or Navigation.

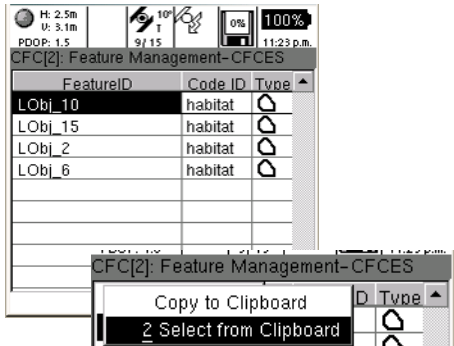

Areas internal to the main feature, or parent area, can be excluded from the calculation. The selection process is identical to selecting a main feature, but it is possible to select multiple features to be excluded. The 09 command will not only provide the number of features excluded, but will provide detail about each feature.

The application does not verify that the area is within the parent object. Be careful when calculating!

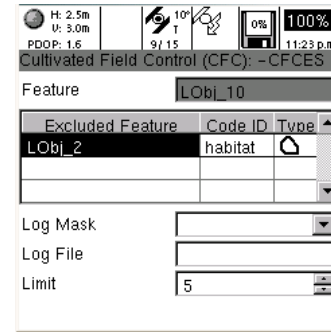

Available mask files will appear in the mask selection box.

A mask file is necessary to create an output file!

- Enter the name of the Logfile to be saved (\Data\APPS\CFC)
- Select a Tolerance or limit of error.

To Calculate, press the Menu key and select Calculate. A log file of the calculation results will appear on screen.

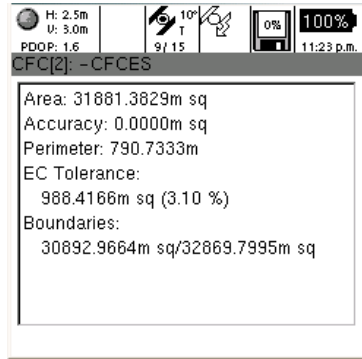

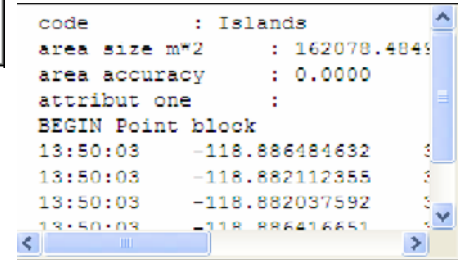
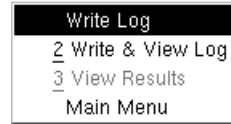

To save your data, and/or get a view of the generated log file, press enter and select Write Log or Write & View Log.



The log file will now be available from the flash card, either directly, or through Sensor Transfer..

Using Power Paging function from the CFC application with an opened log file:

1. In CFC click two times 
2. From Main Menu select **1 Data Collection**
3. Select a feature and occupy the nodes. Save the feature.
4. To return to CFC, press twice 
5. Calculate the next area and attach it to the opened log file.
6. From Main Menu you can page to every opened application.
7. In Main Menu select CFC from the table.

Data Collection
Status
Cultivated Field Control



7.2 File Conversion

7.2.1 ASCII Conversion

7.2.1.1 ASCII Import

The File Conversion application enables the user to Import ASCII into a job or Export a job as ASCII or GSI. This application is accessed by selecting **6 Applications** from the Main Menu and then **2 File Conversion**.



To Import

- Select Import ASCII

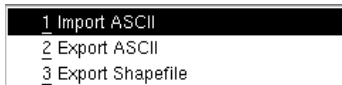

Files to be imported into a job must be placed in the **Data** directory on the Compact Flash card.

If a job is open, the following Import interface will appear:

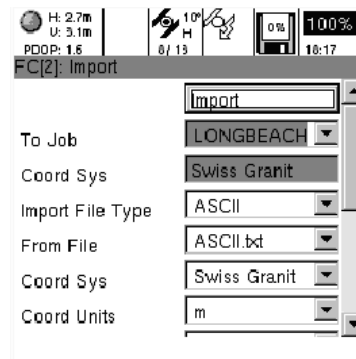

If a job is not open, you will be prompted to open one before proceeding with the import process.



- Once in the Import interface choose the Import File Type.
- Choose the From File - the file to be imported into the current job.

- Select the Coordinate System of the nodes in the file.

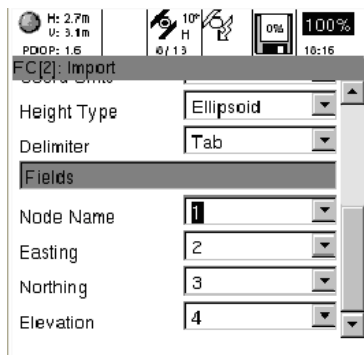

- Select the Coordinate Units of the nodes in the file
- Select the Height Type - Ellipsoid or Orthometric.
- Select the Delimiter - a character marking the beginning or end of a unit of data.
- Select the field position that contains the Node Name, Northing, Easting and Elevation.

7.2.1.2 ASCII Export

- Select **6 Applications** from the Main Menu, **2 File Conversion** and **2 Export ASCII**.



- Choose the **Export File Type**.
- Select the **Format File**. This is a user defined file, created with the assistance of Format Manager office software. This file specifies what data (e.g. Northing, Easting, Code,) are to be passed along in the export file. This file should be created in Format Manager and placed in the Convert directory of the CF card.
- Enter a name (with extension) for the exported file in the **To File** input box.

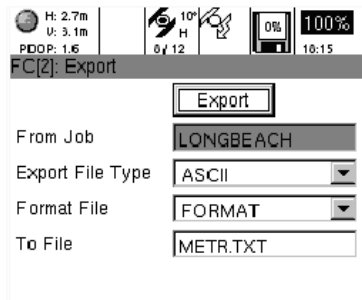

- Select **Export**.

The exported file is placed in the Data directory on the Compact Flash card.

7.2.1.3 ESRI's Shapefile conversion

The File Conversion application enables the user to import ESRI shapefiles as a background map or export a job as ESRI shapefile.

To Import

- Select a job in the Job Management menu

Name	Created
<input type="radio"/> REDONDO	19.06.05
<input type="radio"/> CANCUN	22.06.05
<input checked="" type="radio"/> SHARKEYS	22.06.05
<input type="radio"/> JOB01	22.06.05

Press the Menu button and select Background Maps.

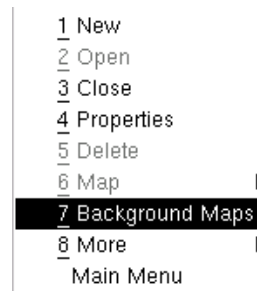

In the Background Maps table, press the Menu button and select Import Shapefile Background.



The following Import interface will appear:

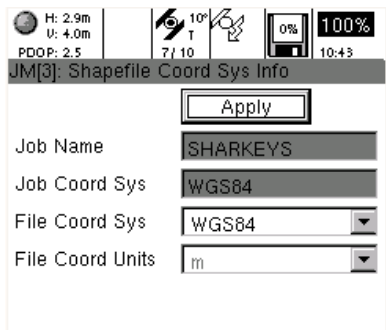

- Once in the Import interface select the folder in which the Shapefile is stored (they are located in the SHP directory of the compactflash card).

- Highlight the Shapefile you want to import and press Menu and Import Shapefile Background to create a vector background data.

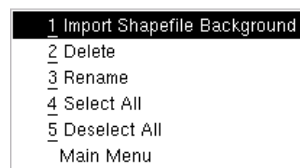
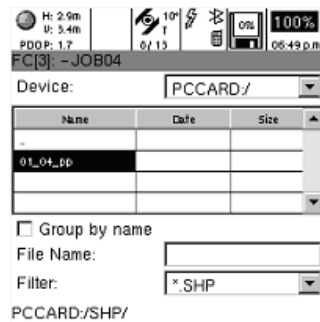

To Export

- Select **6 Applications** from the Main Menu, **2 File Conversion** and **4 Export Shapefile**.



- Select the File Coordinate System and File Coordinate Units.
- Press **Apply**

The exported file is placed in the SHP directory on the Compact Flash card.

8. Utilities

8.1 File Browser

The File Browser is the Leica Geosystems GS20 equivalent of Windows' File Explorer. The file browser provides the ability to view the directory and file structure of the compact flash and system memory. Other functions of the file browser include the ability to:

1. Copy, Paste, Rename and Delete files.
2. Format the Flashcard.
3. Select and Deselect individual, multiple, and all files.



8.1.1 Browser Controls

The File Browser screen can be reduced to four main controls.

- The Device/Path control allows the user to choose between the PCCARD and the SM "System Memory."
- The File list allows the selection of files and directories. To open a directory, press Enter once, to select a file, press Enter twice. Multiple files can be selected and HOME/END PGUP/PGDN are valid.

Tip: To move up one directory, press ".."; Escape will exit the File Browser.

- The Group by name control allows the user to group all job files into a single selection for easier viewing and manipulation.
- The Filter allows for files to be viewed by extension.

8.1.2 Context Menu

Most of the File Browser tools are available via the context menu, including:

- **2 Copy, 3 Paste, 4 Delete**
- Compact Flash **5 Format** utility
- **6 Select All, 7 Deselect All**

8.1.3 Firmware Update

When new firmware (or software) is available for the Leica Geosystems GS20, the update will normally be provided on compact flash media. If however the file is delivered in another format, (e.g. E-mail or ftp) it will need to be copied to compact flash in order to perform the upgrade.

Tip: *It is advisable to load firmware files directly onto a compact flash card via a card reader for the most sufficient firmware upgrade.*

There are three types of firmware upgrades available for the Leica Geosystems GS20 Sensor

1. **Firmware:** Application software (Ven#####.bin)
2. **Sensor:** GPS Engine software (Indigo.run)
3. **Loader:** System boot, diagnostics and upgrade utilities (Loader.Bin)

 All firmware upgrade files must be placed in the GPS\Prog directory. Make sure to have a fully charged battery and exit all applications before beginning the update process. After start is selected, the program will prompt a reboot to begin the update process. After the update is finished the user will be prompted to reboot the device to continue.

8.1.4 Sensor Transfer

Sensor Transfer is used to transfer files between Leica Geosystems GIS DataPRO and the Leica Geosystems GS20 via serial cable or bluetooth. Sensor Transfer provides the ability to choose the port (Port1 or Bluetooth), define the port settings (i.e. baud, parity, bits, etc.) and accept any changes.

Tip: *Device setting are available via the context menu.*

 Because of the exclusive nature of Sensor Transfer, all other applications must be shutdown before beginning a transfer.

8.1.5 Clear System Memory

Clear System Memory: will set all user defined configs, recent settings, ID-templates, stations, ports e.t.c. back to factory defaults. This application requires also a full shut-down immediately after proceeding.

9. Setup

The Setup application contains both default and user defined configurations that determine how a unit operates. Eight default configurations are preloaded on the Leica Geosystems GS20 to allow the user to begin data collection immediately. New configurations can be created and default configurations can be modified, but any modifications to a default must be saved under a different name.

9.1 Selecting, Modifying and Creating Configurations

Several default configuration sets are provided with the GS20 to facilitate the commencement of data collection. New configurations can be created and default configurations can be modified, but any modifications upon a default must be saved as a different name. Below is an explanation of four commonly used default configuration sets provided with the GS20:

- **STATIC** refers to post processing static phase. This type of data collection is used for high accuracy, single point occupations, which require that each ambiguity resolution is a separate calculation. For this type of data collection, a status indicator provides user feedback regarding the appropriate length of time necessary to occupy a data point in order to provide a high level of confidence that the ambiguity of the point will be resolved.
- **KINEMATIC** is also a form of phase data collection. Ambiguities are resolved on an initial static point and then these corrections are applied to all collected data within an unbroken kinematic chain. If, at any time, the number of available satellites drops below 4 the chain will be broken and the user will be required to initialize upon another static point.
- **SBAS**, Satellite Based Augmentation System, is a free real-time or differential correction technique. WAAS is the correction available in North America and EGNOS is the European equivalent.

- **REFOUT** is utilizing the GS20 as a reference station. This configuration will send a real-time message out of a port of the GS20 receiver. The following sections explain how to create new configurations, modify existing configurations and step through the configuration setup of these four methods to better understand their differences.
- **POSTPROC** is the default configuration set for postprocessing code solutions in GIS DataPro.
- **RTNET** enables the GS20 to receive real-time corrections via mobile phone or GSM. This setting allows the GS20 to receive corrections and rebroadcast NMEA on the same port at the same time.

The Setup screen opens to a setup menu that displays the Config Sets, Hardware Management, ID Template Management and Device Management.

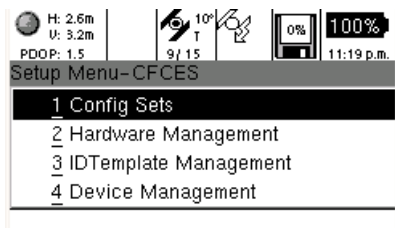

9.1.1 Selecting

A configuration can be selected by selecting Config Sets and highlighting the table row and pressing Enter. The selection is shown by a filled circle or "radio button".

9.1.2 Modifying

If Enter is pressed again on a selected field, Setup will open the configuration for editing. If a Default Configuration is modified, the user will have to **1 Save As** via the context menu, or exit dialog on Escaping.

Tip: *Changes will not take place until the configuration is saved.*

9.1.3 Setting Password protection for your configuration settings

You can protect your user-defined configuration sets with a password. To turn on the password protection you have to check "**Advanced Mode**" in **Hardware Management** -> **Hardware**. The default password is SMARTGUY.

9.1.4 Creating

To create a new configuration from the table, select Menu and choose **1 New**. A text entry dialog will open requiring a name to be entered and saved. The configuration will then be selected and editable.

 When creating a new configuration, values will be copied from the previously highlighted configuration.

9.2 Tree Directory Navigation

The tree style directory menu of Setup groups similar screens into expandable branches. Each branch of the tree can be navigated using the up and down arrows. Sub-branches of a tree are depicted by a “+” to the left of the branch; this can be expanded by pressing Enter. Similarly an expanded branch is depicted by a “-” to the left of the branch and can be contracted by pressing Enter. If no sub-branch exists for a branch, it is an application screen that can be opened by pressing Enter.

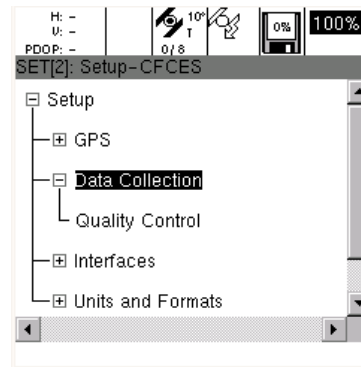

The main branches of the Setup tree, including:

- GPS: Satellite tracking, logging controls and antenna settings.
- Data Collection: Quality assurance and autostop functions.
- Interfaces: External devices connected via wireless or hardware serial ports, NMEA output settings, ASCII input controls and device settings for real-time correction systems.
- Units and Formats: How data is entered and displayed on the unit.

9.3 Hardware Management

Hardware Management is used to modify functions unique to the Leica Geosystems GS20 unit. This is accessed by selecting **8 Setup** from the Main Menu and **2 Hardware Management**.

9.3.1 Hardware

1. Allows the user to personalize the unit name, by default the unit name is the serial number.

☞ The Unit Name directly effects the prefix of the datafile names.

2. Backlight time-out dictates how long the backlight is active after the power key is depressed.
3. Enable or disable the speaker.
4. Character edit time-out changes the amount of time a character is in edit mode. After the time-out the selected becomes an entered value, and the cursor moves right to the next edit field.

9.3.2 Contrast

Provides contrast controls using the left and right arrow.

Tip: *Blind access to the contrast controls are always available by pressing Menu in the Main Menu. (i.e. pressing Menu on Startup or 3 Menus from any screen)*

9.3.3 Wireless (Bluetooth Connectivity)

The Bluetooth connectivity controls provide the user with the ability to select and connect to the Leica Geosystems WoRCS accessory belt and the PC Sensor Transfer unit.

☞ Either a Bluetooth name or the device address will be displayed upon successful inquiry.

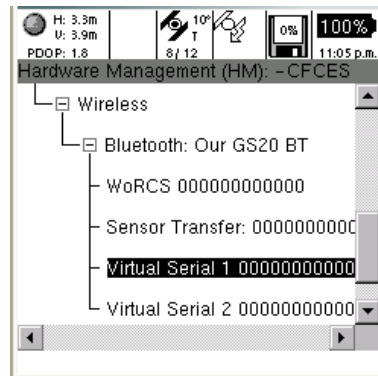

9.3.3.1 Selecting a Wireless Device

1. Expand the “Wireless” and “Bluetooth: Leica” tree branches.
2. Highlight the wireless port to be connected (i.e. WoRCS, Sensor Transfer, Virtual Serial 1, Virtual Serial 2) and press Enter.
3. Select Inquire to search for bluetooth devices. "Please wait..." will be displayed during the search, Cancel will stop the inquiry.
4. When the soft button returns to Inquire, select from the list of Available devices.
5. Select Menu and choose **Save**.

9.3.4 Clearing a Selected Device

1. Expand the “Wireless” and “Bluetooth: Leica” tree branches.
2. Highlight the wireless port to be cleared and select Menu and choose **Clear**.

9.3.5 Real-Time Corrections with a Mobile Phone (RTNet Configuration Set)

Just as real-time corrections can be broadcast over UHF/VHF radio and satellite signals, correction packets can be sent via mobile phone and modem alike. Version 4 builds on the current real-time capabilities of the GS20 by adding GSM and modem capabilities.

Version 4 also provides support for additional RTK data correction formats such as RTCM 18-21, Leica NTrip and Trimble CMR. Finally by using the Bluetooth technology, your real-time correction system can be as small as your GS20 and your phone.

Overview

In order to use the GSM or Modem abilities with the GS20, you must either have a hardware device currently supported (see list), or information concerning the AT commands for a particular device. GSM or modem devices can be connected to the GS20 in 3 ways:

1. Bluetooth connection directly to the GS20: Using a Virtual BT Port.
2. Bluetooth connection via the WoRCS belt: Using Lemo or DB9 connection.
3. Bluetooth connection directly to the GS20: Using a modified cable with RTS/CTS leads.

This cable can also be created by modifying the existing download cable 731354.

☞ This will not affect the functionality of the cable for sensor transfer or connection to external devices.

A reference station list must be defined either on the device, or by a text file which includes:

- Dial in number: Mandatory
- Reference Station name: Mandatory
- Reference Coordinates: Optional. However reference coordinates provides baseline data.

Finally, a configuration must be created that will reference the device being used, the connection type listed above, and the real-time correction format.

9.3.6 Linking with the Bluetooth

The cleanest way to link to a mobile phone is using a Bluetooth Virtual Serial port. Although Bluetooth is a consortium standard, Bluetooth devices don't always work together. By all means, try a device before you buy a device, or call your local Leica support technician.

Making the connect

1. From the Main Menu, select **8 Setup**, and **2 Hardware Management**.

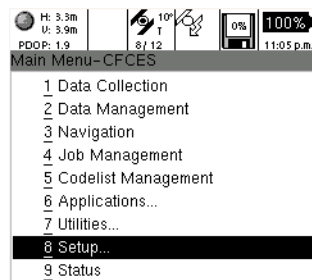

2. At the bottom of the Hardware Management screen, you will find the:
 - Wireless
 - Bluetooth
 - Virtual Serial 1 and 2
 3. Enter the Virtual Screen, and Inquire for a Bluetooth Device.
- ☞ Make sure to expand the list to ensure you have the correct device.
4. Select Menu and Save.

9.3.7 Creating a User Defined Configuration Set with an Existing Device

Configuring your Device

1. From the Main Menu, select **8 Setup**, and **1 Config Sets**.
2. Choose the RTNet default configuration set and enter it.
3. Browse to: + Interfaces -> Realtime

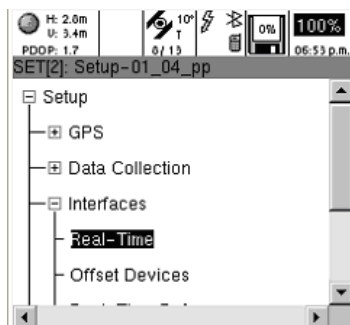

4. Expand Interfaces and highlight Real-Time, press enter.

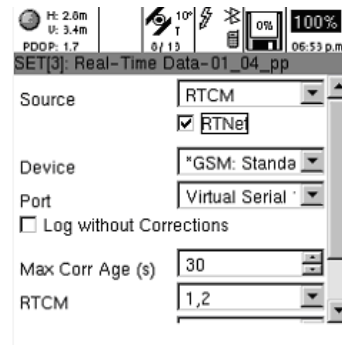

Select your device and port that has been inquired in the previous steps. Max Corr Age (s) defines the time in seconds during a correction is interpolated after the loss of the correction over the GSM.

To enable a service that uses virtual reference stations, check RTNet. This allows the device to receive corrections and sending NMEA strings on the same port at the same time.

By pressing menu and pressing **2 Device Properties** you can modify the data-transfer settings. One AT String you may wish to change is dial. By default it is set to pulse dialing, but it can be set to tone with an additional T.

Dial ATDT^#^M

The Device also requires that a station is selected. However, it is necessary to create a station list or transfer from an external source. To create a station file, select **Menu**, **3 Station** and **2 New**.

From the station list, enter a dialing number and station name. For the initial test, keep the station analog, unless your provider is accepting ISDN connections. You can also add coordinate values if you have them. Pressing the escape button and confirming the dialogues with yes saves your changes. Save the user defined config set and label it according your needs.

9.3.8 Configuring your Device

1. From the Main Menu, select **8 Setup**, and **4 Device Management**.
2. Choose your device from the list, and create a new device based on that.

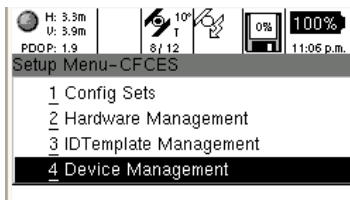

☞ Once you enter the edit field the up arrow is home and the down arrow is end.

3. Modify your Device Name to begin with Z! This makes it easy to access from the bottom of the list.
4. One AT String you may wish to change is dial. By default it is set to pulse dialing, but it can be set to tone with an additional T.
Dial ATDT^#^M
5. The Device Also Requires that a station be selected. However, it is necessary to create a station list or transfer from an external source. To create a station file, select **Menu** and **3 Station**. Create a New Station
6. From the Station list, enter a dialing number and station name. For the initial test, keep the station Analog, unless experience dictates otherwise. You can also add coordinate values if you have them.
7. Save the Station file, and select the newly created station in the Device.

9.3.9 Modifying your Configuration

For this exercise, we will select the existing Beacon configuration, and create a user defined configuration from it.

1. From the Main Menu, select **8 Setup**, and **1 Config Sets**
2. Highlight the Beacon Configuration, Select Menu and Create New
3. Name the configuration GSM or Modem and Select and Open the configuration
4. Enter the +Interface +Real-time Screen
5. From the Real-time, select
 - a. The format of the reference station corrections. (i.e. RTCM, Leica, or CMR)
 - b. The Device Being used (Press the right arrow to go to the end of the list "Z")
 - c. The Port being used (Virtual 1)
6. Save the configuration

If you chose to use a Bluetooth Device

- After saving the Configuration, power off both the GS20 and the Mobile Phone
- Power On both units, and you should be prompted for a Keycode for bonding.

9.3.10 Status Indication

If everything has been configured correctly, you should have

- A real-time icon arrow (hollow)
- A Bluetooth icon, if Bluetooth is used, with a chain "link" beneath it
- A mobile phone icon with a link

9.3.11 Connecting to the Station

From Data Collection, select Feature Occupation, press the Menu key and select Connect.

To disconnect press the Menu key and select Disconnect.

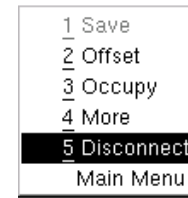
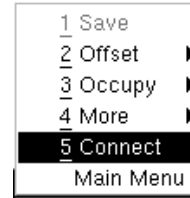

More Status

If your station connects, you will receive a link under the arrow, but it is still hollow.

If your corrections are good you should receive a solid arrow, and an indication in the status bar.

If your corrections are processed with the GPS, your positional icon should be a bullseye, and your qualities will reflect the corrections.

9.3.12 NTRIP

With firmware version 4.0, it is possible with GS20 to access the Internet and to use Internet Services such as the Network Transport of RTCM via Internet Protocol (NTRIP) service.

These notes describe how to configure and use a GS20 sensor as a real-time rover connected to the Internet using a GPRS device and receiving RTCM data from the NTRIP service.



In order to connect to the Internet with GS20 and use the NTRIP Service, it is necessary to have hardware version 2 or higher.

9.3.12.1 An Overview About NTRIP

NTRIP is the protocol for streaming GPS RTCM data over the Internet. For detailed information about NTRIP technology, concepts, documents, different broadcaster addresses and other information, access:

http://igs.ifag.de/index_NTRIP.htm

Also available on this site is information about data transmission rate of pseudorange and carrier phase corrections, latency and accuracy of DGPS data streaming via the Internet.

NTRIP basically consists of three system components:

- NTRIP Clients
- NTRIP Servers (connected to NTRIP Sources)
- NTRIP Caster

The NTRIP Protocol is based on Internet HTTP (Hypertext Transfer Protocol). The NTRIP Caster is acting as the HTTP Server (TCP/IP server), whereas both the NTRIP Client and the NTRIP Server are acting as HTTP Clients (TCP/IP clients).

9.3.12.2 NTRIP Client

The NTRIP Client receives data streams - in our case, RTCM data streams. The NTRIP Client needs to be first accepted by the NTRIP Caster and if authorized, will receive RTK data from the NTRIP Caster. In order to receive RTCM data, the Client needs to send access parameters (user ID and password) to the NTRIP Caster. Additionally the Client has to give the Caster information from which Mountpoint (source) he wants to receive data. If the Client wants to know which Mountpoints are available from the Caster, then the Caster can provide a list of available Mountpoints to the Client in a so-called Source-Table.

9.3.12.3 NTRIP Server

The NTRIP Server transfers RTCM data to the NTRIP Caster using TCP/IP connection. The NTRIP Server needs to be first accepted by the NTRIP Caster and if authorized, can pass RTCM data to the NTRIP Caster.

The NTRIP Source generates the RTCM data streams.



The NTRIP server could be a PC using LEICA GPS Spider.

The NTRIP Server also sends the identification name of the NTRIP Source, the so-called Mountpoint, and other additional information parameters relating to the Source, which identifies the Source to the NTRIP Caster. Such additional information may include which RTCM format is transferred or if the Client (rover) needs to send NMEA positions in order to receive an individualized RTCM stream from a reference station network.

9.3.12.4 NTRIP Caster

The NTRIP Caster is basically an Internet (HTTP) Server, which handles the different data streams to and from the NTRIP Servers.

The Caster checks the received request messages from NTRIP Clients and Servers to see if the Client Server is registered and authorized to receive or provide RTCM data streams. Depending on those messages, the NTRIP Caster decides whether there is streaming data to be sent or to be received.

9.3.12.5 Using GS20 with NTRIP service

How to configure and use a GS20 Sensor as a real-time rover connected to the Internet using a GPRS device receiving RTCM data from the NTRIP service.

Accessing the Internet with a GS20 Sensor

 When using a GPRS device to connect a GS20 sensor to the Internet, then the sensor will always be used as an Internet TCP/IP Client - this is one of the "features" of using a GPRS device to connect to the Internet. Operating the sensor as an Internet Client means that the sensor connects to another "Computer" in the Internet in order to receive RTCM corrections.

To connect a GS20 with a GPRS device please refer to the chapter 9.3.6 "Linking with the Bluetooth".

1. From the Main Menu, select 8 Setup, and 1 Config Sets.
2. Choose the RTNet default configuration set and enter it.
3. Browse to: + Interfaces -> Realtime
4. Select your previously configured GPRS device
5. Press the Menu key and select Device Properties

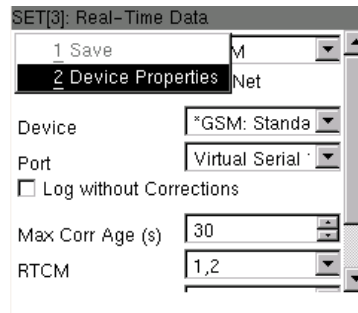

SET[3]: Real-Time Data

1 Save M

2 Device Properties Net

Device *GSM: Standa

Port Virtual Serial

Log without Corrections

Max Corr Age (s) 30

RTCM 1,2

6. Press the Enter key to enable GPRS/Internet and further down Use Internet at the bottom of the Device Property table. You can enter a name for this Internet Profile or choose from an existing list, if you have already configured one.

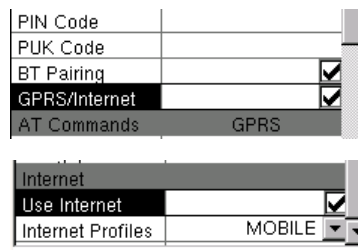

PIN Code	
PUK Code	
BT Pairing	<input checked="" type="checkbox"/>
GPRS/Internet	<input checked="" type="checkbox"/>
AT Commands	GPRS

Internet	
Use Internet	<input checked="" type="checkbox"/>
Internet Profiles	MOBILE

- Press the Menu key and select Internet and New for a new Internet configuration



- In the Internet Profile Property table can change between your different profiles (so-called Devices) if you have previously configured it.

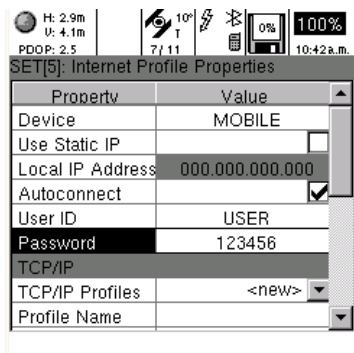

- Select Use Static IP if your GPRS provider don't distributes dynamic IP's. In most cases you don't have to enable Static IP. In this case leave Local IP Address blank.

- Check Autoconnect if you want an automatic reconnection after a loss of connection

- User ID and Password has to be completed if your GPRS provider requires this information. In most cases you can leave it blank.

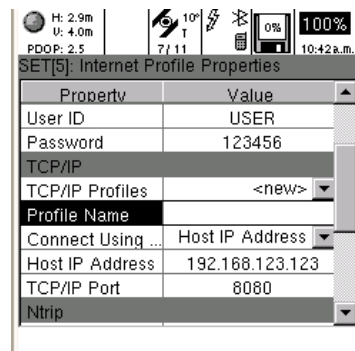

- In the TCP/IP settings you can either choose from a list of profiles if you have already configured one, or create a new by simply typing in a name.

13. In the "Connect Using..." tab, you can select Host IP Address which is the Internet Protocol address of the NTRIP Caster or you can select Host Name, which requires a Domain Name Service (DNS) from your GPRS provider. The TCP/IP Port defines the port on which NTRIP is streamed.

14. Enable "Use NTRIP". Again you can choose from a list of already configured profiles or you create a new.

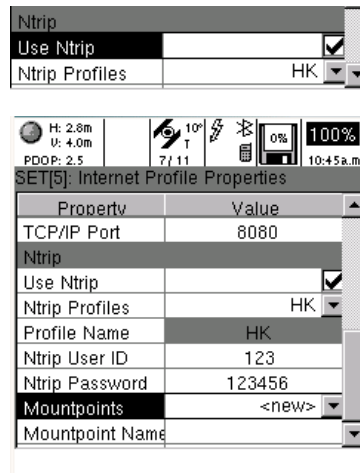

15. Complete the NRIP User ID and NTRIP Password which are given from the NTRIP service provider. Passwords are in most cases case-sensitive. You can change from Upper to Lower case by pressing the Menu key and selecting Lower or Upper Case.



After the first connection to the NTRIP service you have a list of Mountpoints from where you can select which format you want. If the Mountpoint is already known you can complete it by pressing the Enter key.

16. Establish the connection by pressing the Menu key and selecting Connect in the Data Collection Menu.

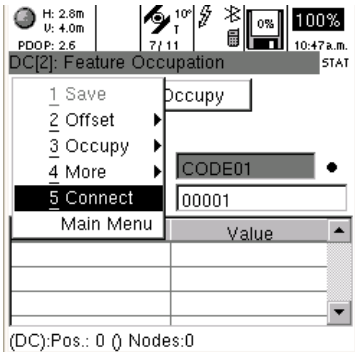

9.4 ID Template Management

The ID Template Management application allows for points, auxiliary points (offset base points), lines, and area features to be automatically and sequentially marked for easier selection and query. Templates can be modified, created and Deleted via the context menu.

By Default, each existing ID Template type comes with two existing templates. Time and Date, and the Template type followed by ##### (e.g. Point00001). Additionally, No Template can be selected, allowing for manual entry by the user.

9.4.1 Creating an ID Template

1. From the ID Template Manager, select Menu and choose **1 New**.
2. Choose the Object Type from the drop down picklist.
3. Enter a template Prefix (i.e. USGS)
4. Select the start number, otherwise defaulted to 1.
5. Select an auto increment number.

9.4.2 Modifying an Existing Template

1. In the ID Template Manager, select the Object Type to be modified.
2. Select the ID Template Name to be modified.
3. Edit the Prefix, Start # and Auto Increment fields.
4. Select Menu and enter on **Save**.

9.5 Device Manager

The Device Manager provides a library of all devices available for Real-Time, Offset, and ASCII Input. The Device Manager allows for existing devices to be modified and new devices to be created.

9.5.1 Creating a New Device

1. From the Device List, select Menu and choose **1 New**.

Tip: The Properties of the previously highlighted device will be copied, including the next sequential number of the Device name.

2. Edit the Device name, and edit the hardware port settings if necessary.
3. Select Menu and choose **Save**.

9.5.2 Modifying an Existing Device

1. From the Device List, select Menu and choose **2 Properties**.
2. Modify the Device name, and edit the hardware port settings if necessary.
3. Select Menu and choose **Save**.

9.6 GPS Controls

The GPS subgroup allows the user to specify tracking and logging parameters, set antenna parameters and enter initial coordinates for first time tracking to a new region.

9.6.1 Tracking

The tracking screen is comprised of three controls.

- **Max Accuracy / Max Track / Hyper Track** radio button: Max Track and Hyper Track are Leica Geosystems innovations that allow for signals to be tracked at a lower strength threshold to provide reception in dense foliage.

Tip: Max/Hyper Track does not allow for phase collection. High precision points should be collected in Max Accuracy.

- **Mask Angle** - the angle above the horizon which determines the cutoff for tracking satellites.



Because a greater distance through the atmosphere must be penetrated for low elevation satellites, a default of 10 degrees is preset and recommended as a minimum!

- The **DOP**, or Dilution of Precision Filter is user definable mask based on satellite geometry. This is a setting normally used for autonomous (i.e. correctionless) collection.

9.6.2 Minimum Satellites

The Minimum Satellite control allows the user to define how many satellites must be tracked to calculate a positions. The default setting is 4 satellites, because a minimum of 4 satellites is necessary to calculate a 3 dimensional position.



Three satellites can calculate a position assuming a fixed ellipsoidal elevation; however this is only recommended for navigational purposes.

9.6.3 Antenna Type

A default library of 3 antenna types is available, the Leica Geosystems GS20 Internal, the AT501 Pole (external), and the AT501 Tripod (external) and AT1201. For normal use, the user only needs to define the height of antenna above the point being occupied.

Tip: The Leica Geosystems GS20 automatically senses when an antenna has been plugged in or unplugged. The unit opens and resets the antenna configuration accordingly.

9.6.4 Logging

The Logging screen contains controls to store raw pseudo-range data for post-processing, static and moving observations, and positional update rate for the receiver (default 1 second.)

 **Data collected without enabling the logging cannot be post processed for corrections!**

To enable post processing, select the static or moving check box and set the observable logging rate. This rate controls both moving and static logging rates, so it is recommended that 1 second be used when collecting lines and areas in a job.

9.6.5 Initialization

The time and initial position controls help the unit to obtain satellites faster in a new geographic location or when there is no almanac data present on the unit.

Time/Date and position controls can be edited by selecting 8 Setup, 2 Hardware Management, GPS, Initialization.

 New almanac data is sent by a satellite every 12.5 minutes. After the first position is calculated, the Time and Initial Position fields will update to reflect the last position.

 Valid limits are 0-90 degrees for Latitude and 0-180 degrees (East and West) for Longitude.

9.7 Data Collection

The Data Collection subgroup is where quality minimums are defined for both automatic collection and notification alarms.

9.7.1 Quality Monitor

The Quality Monitor controls are subdivided into Point Quality (which is also applicable for linear node collection) and Line/Area streaming.

Point Quality

1. Point Quality can be reported in terms of horizontal, vertical, horizontal & vertical or none.

 If only Horizontal or Vertical quality is chosen, the other edit field will be disabled!

2. Point Autostop:

- None: Occupation is manually controlled (i.e. started and stopped) by the user.
- Quality: The occupation will be stopped once the Quality defined (e.g. Horizontal) is achieved.
- Positions: The occupation will be stopped once the number of positions required are collected.

 Positions must achieve the required quality to be stored.

3. CQ Warning (Coordinate Quality): Even if Point Autostop is set to none, a notification alarm can be set to alert the user that the defined quality has been exceeded.

Line Quality

1. Defines the horizontal quality tolerance for linear streaming.

Tip: *The Line Quality can be used to filter or just notify the user of positions that exceed quality. This setting can be found in the Streaming Options in Data Collection.*

9.8 Interfaces

The Interface subgroup controls how external devices interact with the Leica Geosystems GS20. The interfaces are further subdivided into Real-Time, Offset Devices, and NMEA Output.

9.8.1 Real-Time

Real-Time or “Differential” correction allows a GPS to use a known reference position to correct the less accurate autonomous position. The Leica Geosystems GS20 supports two combined message formats of the RTCM “Radio Technical Commission for Maritime services” standard. RTCM (9,2) (1,2) (18,19) and (20,21).

Several default devices are available for Real-Time Interface.

- RTB: CSI Real Time Coast Guard Beacon.
- RTS: Racal LandStar Satellite Subscription Service.
- RS232: An open standard for 3rd party devices.
- GSM
- Modem Devices

To view or edit the properties of the device being used, Select Menu and choose **2 Device Properties**.

Tip: *Additional properties unique to a device such as the RTB (Frequency, Bit Rate) and RTS (Channel and Station) can be defined by the user in Device Properties.*

Port: Three ports are currently available for connection to a Real-Time device.

- Port 1: Serial Lemo connection on the bottom of the GS20
- WoRCS 1: The 5 pin Lemo Port located on the bottom of the WoRCS Bluetooth Hub.
- WoRCS 2: The 8 pin Lemo Port located on the switch side of the WoRCS Bluetooth Hub.

 The Bluetooth must be connected to the WoRCS in the Hardware Management.

Log without Corrections: If Real-Time corrections are lost, data can continue to be recorded for post-processing in the GIS DataPRO office software.

Maximum Age of Correction: The user can define how long to use corrections to calculate a Real-Time position after the correction source is lost.

 **Although old corrections can be used for longer time periods, the degradation of quality becomes exponential with time.**

RTCM: The user can choose from type (9,2) which is used with RTB Coast Guard Beacon, or (1,2) which is used with RTS and other Satellite correction sources.

 (See above section ALMANAC for further explanation)

9.8.2 GS20 Phase Wizard

This document is intended to provide the user with insight into how the Phase Wizard works, and step-by-step instructions on its use. Because the GS20 can be used with both SKI PRO and GIS DataPRO, both platforms will be discussed below. For additional information about the use of SKI PRO or GIS DataPRO, please refer to the documentation included with those packages.

9.8.2.1 Overview

The phase wizard was created to provide the user with an easy to use interface for collecting high-accuracy data with the GS20. Additionally, the phase wizard collects data in a way that can be processed more efficiently in SKI PRO or GIS DataPRO, creating a simplified process for the user in the field and office.

The GS20 Phase Wizard allows the user to select from Static Phase Collection, Kinematic Phase collection, or No-Phase (Code only) Collection. By choosing one of these methods, the setup/configuration file is automatically modified without additional input from the user.

9.8.2.2 Static Phase

Static Phase collection is optimized for high accuracy single point occupations, which require that each ambiguity resolution be a separate calculation. In order to optimize this collection, moving or kinematic chain data is not logged and streaming occupation is unavailable.

In this configuration, the user will enter antenna height and baseline length from the reference station. A status indicator will then provide user feedback on the length of time needed to occupy a point to provide a high level of confidence that the ambiguity of the point will be resolved.

9.8.2.3 Kinematic Phase

Kinematic Phase collection is designed to resolve ambiguities on an initial static point, and apply those same corrections to all collected data within an unbroken “kinematic chain”. The user is prompted to occupy a initialisation point, and the method of collection is similar to that of static phase collection. Once the point has been occupied for a sufficient amount of time based on satellite geometry, baseline length and antenna parameters, indicated by a status bar. Point and linear streaming data can be collected in a normal fashion. If, however, at any time the GPS lock drops below 4 satellites, the phase chain will be broken and the user is required to initialize another static point.

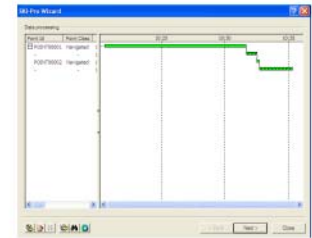
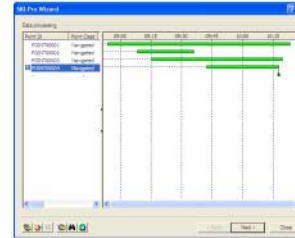

9.8.2.4 The Interface

In order to select a mode of phase collection, the user simply needs to press the menu button in the Codes screen. The user will then have the ability to select from three modes of collection:

1. No Phase
2. Static Phase
3. Kinematic Phase

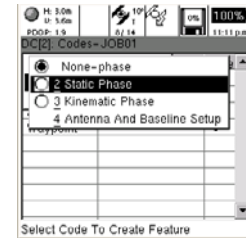
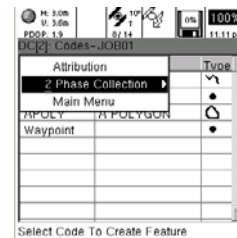

When a phase mode has been switched, a message will pop up to indicate that configuration settings may have been changed. If you are currently in a default configuration, the system will indicate that the changes must be saved into a new configuration, and a prompt will appear to name that configuration.

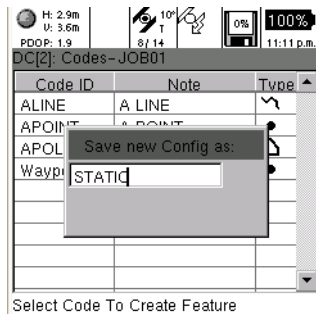
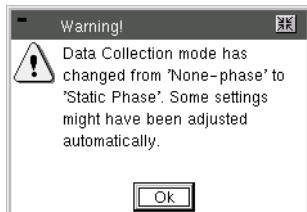

9.8.2.5 Collecting Static points, including kinematic points of initialization

A status indicator reports the amount of occupation time required to resolve phase ambiguities. This figure is based upon the number of satellites, satellite geometry and the baseline length to the reference GPS.

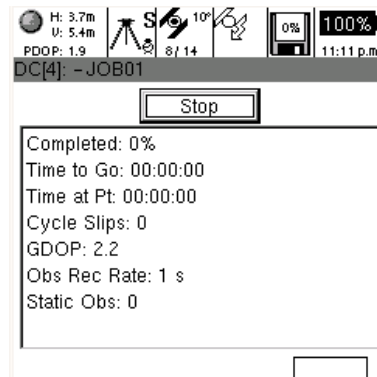

In order to provide the correct information, the user must enter a baseline selection. Both the baseline length and antenna height of an occupation can be entered from the menu dialog in the codes screen.

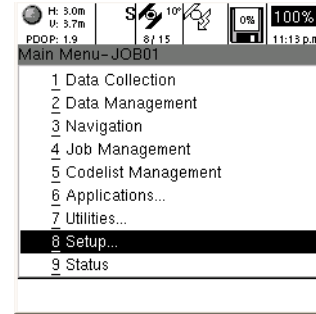
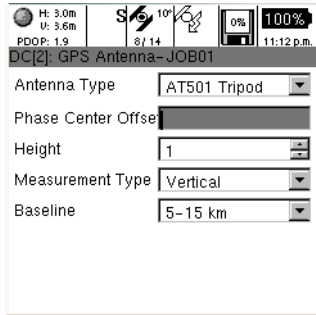
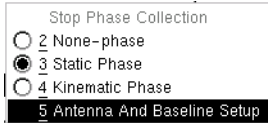

9.8.3 SBAS

The Satellite Based Augmentation System or SBAS is a free real-time correction. The system available in North America is referred to as WAAS and is comparable to the European EGNOS correction, currently in a testing phase. These corrections are broadcast on the same frequency as GPS, can be received without the need for additional hardware and are free of charge. To set SBAS as the active correction, you can either use the default configuration, create a new configuration or edit a user defined configuration.

1. Select **8 Setup** from the Main Menu and **1 Config Sets**. SBAS is selectable from this MENU.

2. The simplest way to receive a SBAS correction is to select the default.

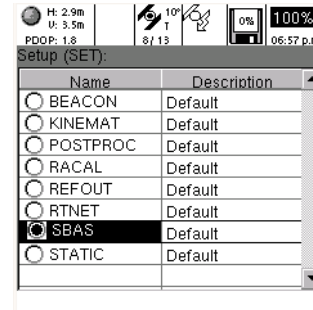

- Most likely, you will want to select a User Defined configuration or press Menu and create a New configuration based on your highlighted default.

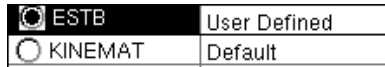

- Enter the configuration, and expand the interfaces branch. Select Tracking and press the Enter key.

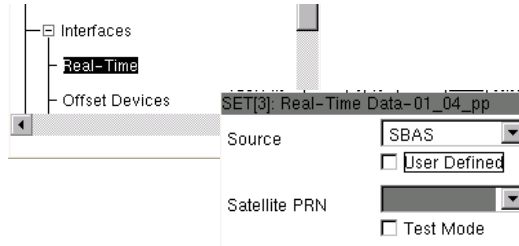

- Set the source to SBAS.

9.8.3.1 Understanding the SBAS Corrections

- The immediate and most notable change will be the SBAS Satellite Icon in the real-time window. This indicates the unit is set for SBAS corrections.



- When the icon becomes a solid fill, this indicates that the SBAS signal is being received.
- Once the corrections have been calculated, the SBAS Satellite Icon will become Bold, the status bar will indicate Reference Data is Available, and the positional Indicator will become a bulls eye.
- SBAS corrections are able to extrapolate, or coast for 60 seconds. If the correction is lost, a numeric indicator under the SBAS Satellite Icon will display how many seconds since the last correction.
- SBAS Satellites can be viewed in the Satellite Status Screen. SBAS Signal Strength is also indicated in the Status Real-time Screen.

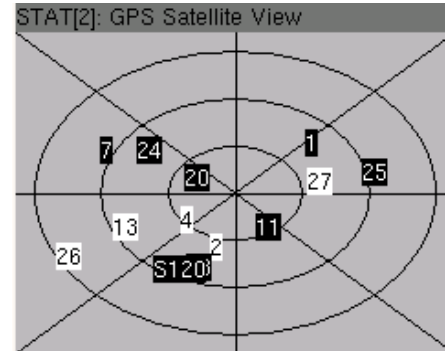

9.8.3.2 Changes to the Real-Time Screen

A new Source selection allows the user to select none (no correction), SBAS, RTCM (Including Real-time Beacon, and Real-time Satellite), Leica and Trimble CMR.

If the RTCM, Leica or Trimble CMR source is selected, you must then specify a device.

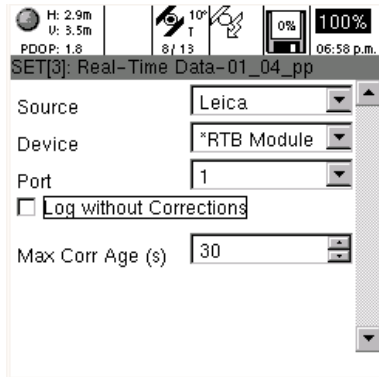

 New devices can be created and configured in the Setup \ Device Management screen.

User defined quality settings can determine how the feature is collected (see Setup\Data Collection.) In addition to direct locations, the user can also choose from a list of point offsets.

9.8.4 Connecting to WoRCS Beacon

If you purchased the Leica Geosystems GS20 with the Wireless real-time Correction System (WoRCS) you are only steps away from collecting real-time sub-meter data. The WoRCS comes preconfigured with Bluetooth linked to your GS20.

WoRCS Belt

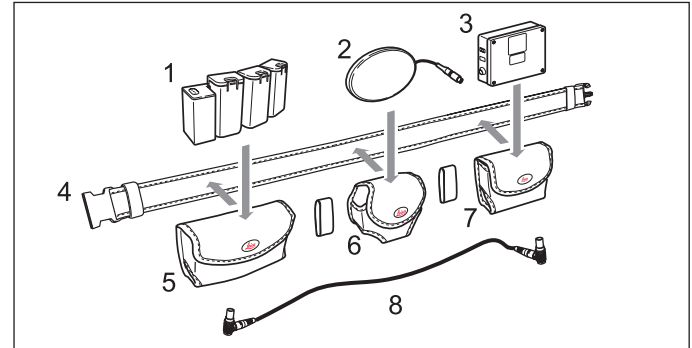

9.8.4.1 Powering on the WoRCS

1. The Bluetooth Module is the only belt item with configurable controls. By default, power should be set to on and line should be set to Bluetooth.
2. Follow the procedure listed previously for charging the batteries. Once the batteries are fully charged, you can place them in any of the three bays of the battery insert shown below. The battery insert is both hot swappable and self-switching. The batteries will be drawn down from bay one to bay three without interruption in power.

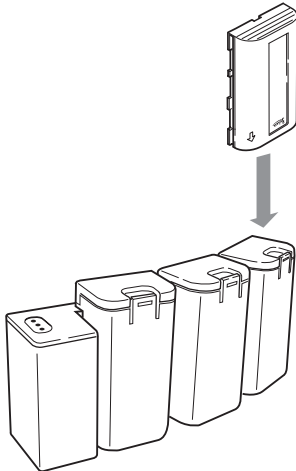

9.8.4.2 Checking the Bluetooth Link

If your Bluetooth link is successfully connected, the bluetooth icon with a chain below and a status message “Bluetooth Link Restored” will appear at the bottom of the screen. You can now proceed to checking the real-time link: If not, follow the steps listed below:

1. Power on the GS20 and select **8 Setup, 2 Hardware Management** and the **Bluetooth_Wireless Selection**.
2. Expand the Wireless tree, expand the Bluetooth, and view WoRCS.
3. If the GS20 has been linked to the WoRCS Bluetooth Module, an address that corresponds to the address on the top of the Bluetooth Module will appear. If the address does not correspond, press **menu** and select clear.
4. If the address area displays zeros, you will need to establish a connection.
5. Highlight the WoRCS branch and press enter; this will take you to the Bluetooth Setup screen.
6. Press Inquire and wait until the Cancel button becomes Inquire again.
7. You will see the Available Devices in the choice list. By highlighting the available devices and pressing Enter, you will see the entire list of available bluetooth devices in the choice list. If multiple devices have been found, select the device that matches your WoRCS bluetooth address, displayed on the top of the bluetooth module.

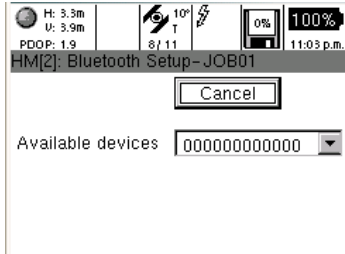

8. Finally, press the **Menu** key and Save, then **Escape** back to the main menu.

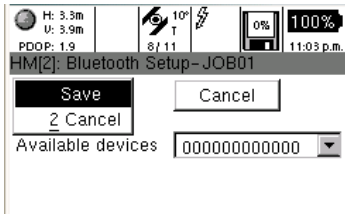

Tip: *Ensure batteries are charged and correctly inserted. Ensure bluetooth module is set to line and on. The single flashing red light indicates that power is available. When the light changes to green a BLUETOOTH connection is established but no data is exchanged. When both green lights are flashing data is exchanged.*

9.8.4.3 Checking the WoRCS Real-Time Link

Once the Bluetooth Link is established, you will need to make sure that your real-time device is linked and active. If the status message “Reference Data is Available” appears, setup is complete, and there is no need to proceed any further. Otherwise, follow the steps of the status check below.

9.8.4.4 WoRCS Real-Time Beacon

1. From the Main Menu select **9 Status**. Expand the Interfaces branch and select Real-Time. If you have communication with the Real-time Beacon module (RTB), you will see information about the frequency, signal strength etc; otherwise, you will see all zero values.

 The real-time screen does not refresh automatically; to refresh the values, you will need to escape and re-enter.

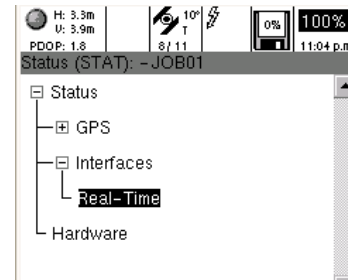

2. If the Real-time values are all zero, there is no communication to the real-time beacon module. So you will need to verify the configuration.
3. Escape to the Main Menu and select **S Setup**.
 - ☞ Verify the user-defined configuration named "WORCSBCN" is selected; if "WORCSBCN" exists and is not selected, highlight and press Enter, otherwise select the default "Beacon".
4. Press **Enter** again on the selected configuration to edit the setup values.
5. Expand the Interfaces branch, highlight the Real-time branch and press enter.
6. Make sure the Device is set to RTB, and the port is set **WoRCS 2**.

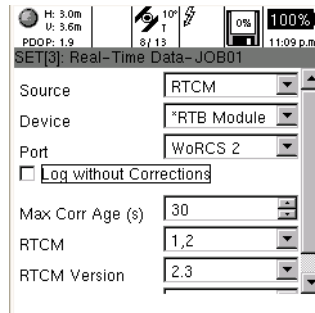
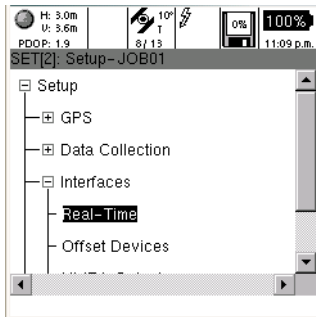

7. **Escape** and save the values, press the Escape key and save the configuration.

☞ If you are editing a default configuration, you will be prompted to provide a configuration name.

8. **Escape** to the main menu, and return to the status/Interface/Real-time branch to check the status of the real-time device. You should now see values for the frequency, bitrate, etc.

9.8.5 Connecting to WoRCS Real-Time Satellite (RTS)

If you purchased the Leica Geosystems GS20 with the Wireless real-time Correction System (WoRCS), you are only steps away from collecting real-time sub-meter data. The WoRCS comes preconfigured with the Bluetooth linked to your GS20.

WoRCS Belt

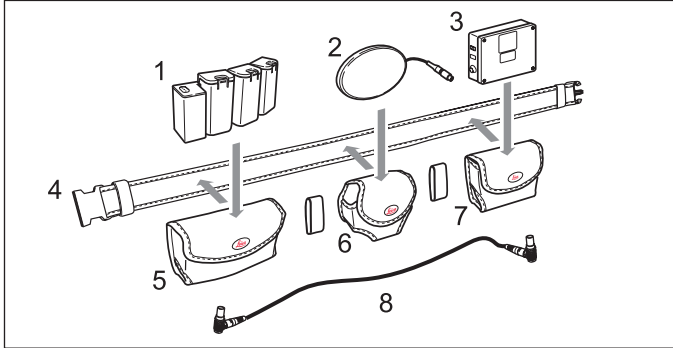

1. WoRCS Power Supply Module
2. WoRCS RTB Module
3. WoRCS BLUETOOTH Module
4. WoRCS Belt with Belt keepers
5. WoRCS Power Supply Jacked
6. WoRCS RTB Module Jacked
7. WoRCS BLUETOOTH Module Jacked
8. Power Supply to BLUETOOTH Module Cable

9.8.5.1 Powering on the WoRCS

1. The Bluetooth Module is the only belt item with configurable controls. By Default, Power should be set to On, and Line should be set to Bluetooth.
2. Follow the procedure listed previously for charging the batteries. Once the batteries are fully charged, you can place them in any of the three bays of the battery insert shown below. The battery insert is both hot swappable and self-switching. The batteries will be drawn down from bay one to bay three without interruption in power.

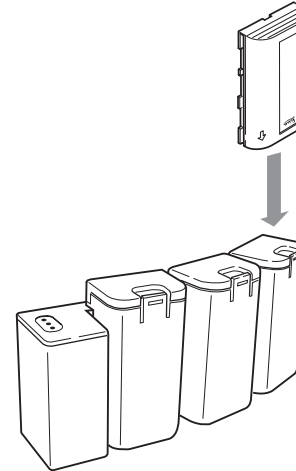

9.8.5.2 Checking the Bluetooth Link

If your Bluetooth link is successfully connected, you will see

the bluetooth icon  appear with a chain below and a status message “Bluetooth Link Restored” will appear at the bottom of the screen. You can now proceed to Checking the real-time Link; if not follow the steps listed below:

1. Power on the GS20 and select **8 Setup, 2 Hardware Management** and the **Bluetooth_Wireless Selection**.
2. Expand the Wireless tree, expand the Bluetooth, and view WoRCS.
3. If the GS20 has been linked to the WoRCS Bluetooth Module, an address that corresponds to the address on the top of the Bluetooth Module will appear. If the address does not correspond, press **menu** and select clear.
4. If the address area displays zeros, you will need to establish a connection.
5. Highlight the WoRCS branch and press enter; this will take you to the Bluetooth Setup screen.
6. Press Inquire and wait until the Cancel button becomes Inquire again.

7. You will see the Available Devices in the choice list. By highlighting the available devices and pressing Enter, you will see the entire list of available bluetooth devices in the choice list. If multiple devices have been found, select the device that matches your WoRCS bluetooth address, displayed on the top of the bluetooth module.

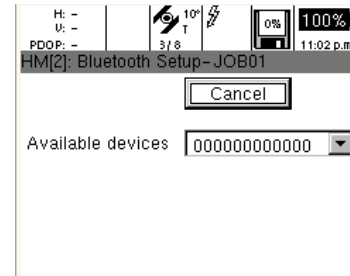

8. Finally, press the **Menu** key and Save, then **Escape** back to the main menu.

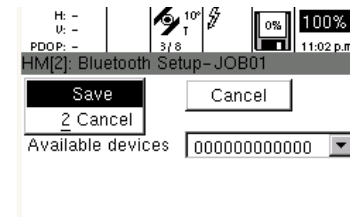

Tip: Ensure batteries are charged and correctly inserted. Ensure bluetooth module is set to line and on. The single flashing red light indicates that power is available. When the light changes to green a BLUETOOTH connection is established but no data is exchanged. When both green lights are flashing data is exchanged.

9.8.5.3 Checking the WoRCS Real-Time Link

Once the Bluetooth Link is established, you will need to make sure that your real-time device is linked and active. If the status message “Reference Data is Available” appears, setup is complete, and there is no need to proceed any further. Otherwise, follow the steps of the status check below.

9.8.5.4 WoRCS RTS

1. From the Main Menu select Status. Expand the Interfaces branch and select Real-Time. If you have communication with the Real-Time-Satellite module (RTS), you will see information about the Station ID, frequency, signal strength etc.

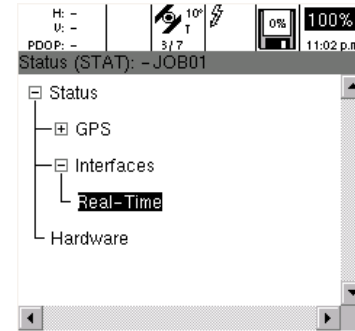

- ☞ The real-time screen does not refresh automatically; to refresh the values, you will need to escape and re-enter.
2. If the Station = -1, this means the RTS Unit does not have a subscription. You will need to contact Racal-LandStar to check the status of your subscription. To find the office nearest you, go to www.omnistar.nl (former RACAL Landstar).
 3. If the station id is present and all lights are on, on the RTS Module, escape to the Main Menu and select **8 Setup**.
- ☞ Verify the user-defined configuration named "WORCSRTS" is selected; if "WORCSRTS" exists and is not selected, highlight and press Enter, otherwise select the default "RACAL".

4. Press **Enter** again on the selected configuration to edit the setup values.
5. Expand the Interfaces branch, highlight the Real-time branch and press enter.
6. Make sure the Device is set to RTS, and the port is set to **WoRCS 1**.

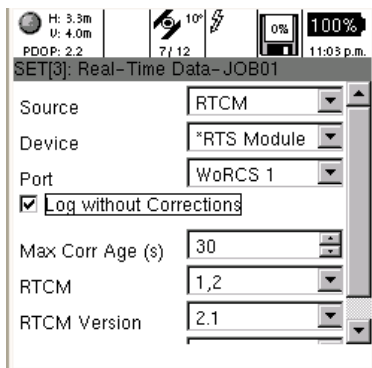

7. **Escape** and save the values, then escape and save the configuration.

 If you are editing a default configuration, you will be prompted to provide a configuration name.

8. **Escape** to the main menu, and return to the status/Interface/Real-time branch to check the status of the real-time device. You should now see values for the Station ID, frequency, bitrate, etc.

9.8.6 Offset Devices

9.8.6.1 Configuration of the GS20

When points cannot easily or accurately be accessed by direct GPS occupation, you have the option of calculating using an offset method.

The GS20 offers four point offset collection methods and works with most laser range finders.

The bluetooth modul supports laser range finders and transmits the data cablefree to the GS20.



Leica DISTO plus - the innovative hand-held laser meter for fast and easy distance measurements of length, squares and volumes with the press of a button.

The DISTO plus can be interfaced with the GS20 directly via bluetooth. Data can then be transmitted to the GS20 cable free.

☞ If using a DB9 cable interface, it may be necessary to use a null modem.

A null modem switches the 2 and 3 pin of a serial interface.

Once the Rangefinder is connected to the system via one of the above methods, you will need to configure the port for the specific device. This will depend upon the device you are using and how you chose to connect it to the system.

1. From the GS20 Main Menu, select Setup and Enter your selected configuration.

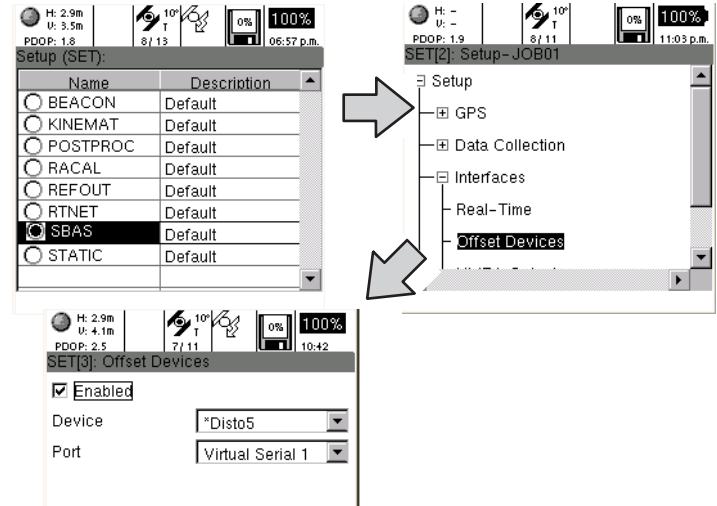

2. Expand the Interface branch and select Offset Devices.
3. Select the appropriate device and the corresponding port. Selecting Virtual Serial connects to the GS20 via bluetooth.

 Before connecting with the DISTO plus, make sure the bluetooth setting of the Virtual Serial Port has been inquired and saved.

4. Escape and save changes. Once you have the device and port settings set to match the offset device and port connection you are using, you will be ready to collect data.

9.8.6.2 Overview of the basic methodologies of point offset data collection

When collecting a point offset, it is important to input the offset data before occupying the auxiliary point.

Azimuth Distance: Enter Azimuth, Distance and Delta Height before occupying the point.

Azimuth Azimuth: Enter Azimuth and Delta Ht for 1st position from Aux Pt. A; then repeat for PT B.

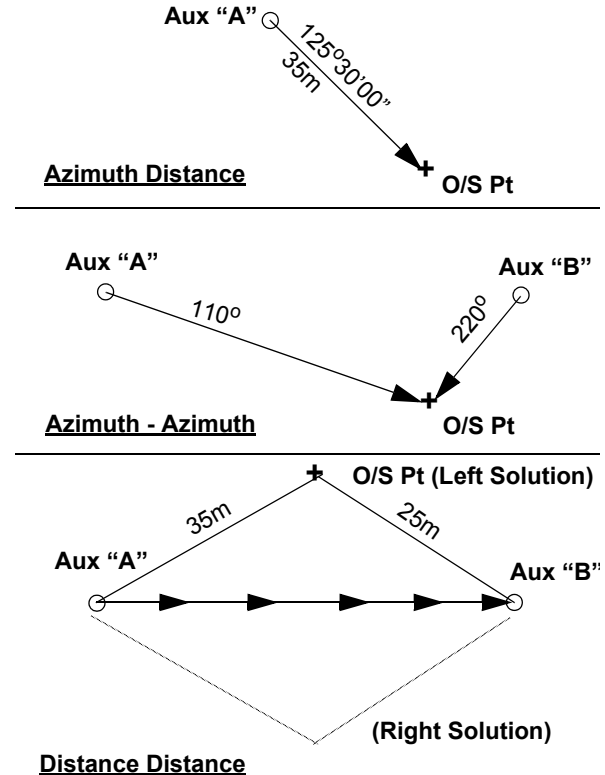

Distance Distance: Enter Distance and Delta Ht for 1st position from Aux Pt A; repeat for position B and choose the solution method (i.e. Left or Right)

☞ Because two solutions exist for a double distance intersections, the user must tell the software on what side of point A-B the offset point lies.

Backwards Azimuth and Distance: Useful when locating a point by direct occupation when no GPS exists. This works by providing an azimuth and distance to a previously located point. The calculation then reverses the course and distance.

9.8.6.3 Explanation of individual point offset data collection methodologies

To Collect a Point using offset methods, select the desired code as you would for a standard point collection. In the feature collection screen, select Menu and choose 2 Offset. You will then be presented with the following options for collection:

1. Once in the offset screen, select Azimuth Distance.

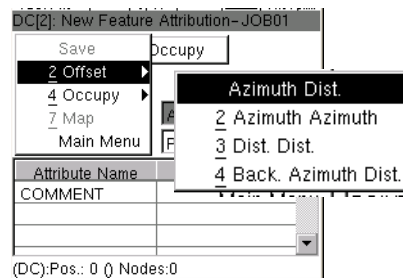

2. Collect the value with your rangefinder or enter them manually.

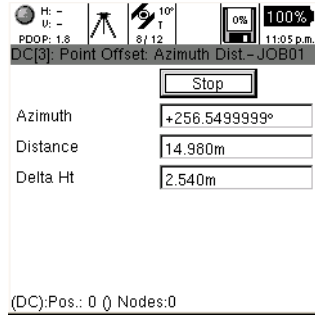
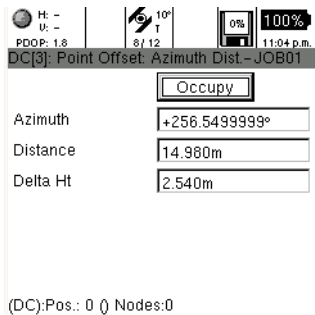

3. If your rangefinder only calculates a distance, you must manually enter the other parameters.
4. Select Occupy, similar to normal point collection. Both manual and auto-stop work in offset occupation.



Although a default Auxiliary or base point is created for the offset, you can use the geo-clipboard to select from a stored base point for multiple occupations.

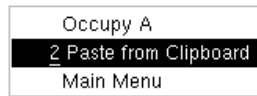

Double Azimuth or Double Distance.

Collecting an offset using double Azimuth or Double distance methods requires collecting both range and occupation information from two locations.

1. Populate the “A” fields manually or with a range finder, then occupy the point.
2. After the “A” occupation has taken place, the “A” fields are no longer editable.
3. Populate the “B” fields, then take the “B” occupation.
Escaping will allow for points to be re-occupied, however it is not possible to keep the “B” collection and re-occupy “A”.

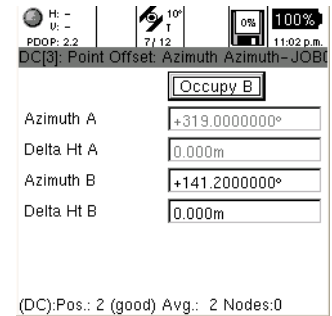
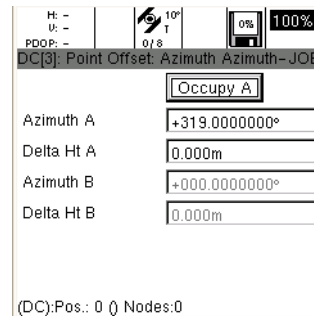

Reverse Azimuth and Distance.

The backward, or reverse Azimuth and Distance method allows you to calculate your position, by sighting a reference point of known origin.

A known node or point feature must be copied to the Geo-Clipboard.

The node or point can be copied to the Geo-Clipboard by map or table in Data Management or Navigation.

The known feature is automatically selected from the Geo-Clipboard in the offset screen. No Occupation is necessary.

DC[4]: Point Offset: Back. Azimuth Dist.

From Point (Paste)	POINT00001
Azimuth	+014.0000000°
Distance	25.000m
Delta Ht	0.000m

Pos.: 0 0 Nodes:0

By Calculating the backward azimuth distance offset without populating the fields (i.e. zero), it is possible to create new features with a shared topology to the parent “pasted” node. This topology is maintained when the parent node is post-processed or deleted.

9.8.7 ASCII Input

Data from external devices can be incorporated into node and feature data for applications such as:

- Photos hyperlinked to features.
- Depth Finders to range water depth from a GPS position
- Bar Code Scanners

To link an external ASCII Device:

1. Set the RS232 Device Properties by Selecting Menu and choose **2 Device Properties**.
2. Select the Port to be used.
3. Define if the ASCII device being defines the end of message by CR “Character Return”, LF “Line Feed” or a combination of the two.
4. Select User Defined if the ASCII information should be written to an Attribute field. If selected, enter the name of the Attribute field.

9.9 Units and Formats

Units and Formats allow the Leica Geosystems GS20 to be entered and display according to the users specifications.

9.9.1 Units of Measure

A list of choice controls defining

- Length
- Area
- Velocity
- Angle Units
- Angle Formats (And Point of Reference)

Tip: *Magnetic Azimuth and Bearing Information can be entered and displayed. However, the user must define the local declination.*

9.9.2 Language

Language selections for the software interface can be selected if additional language files are available on the unit.

9.9.3 Formats

- Local Time Zones (Arranged by distance from Greenwich Mean Time)
- Daylight Savings Time: Check box
- Date Format
- 12/24 Hour or Civilian/Military Time
- Coordinate Format: Radio Button

10. Status

The Status application of the Leica Geosystems GS20 provides feedback concerning current position, satellite location, signal strength, real-time differential corrections, and system information.

Similar to Setup, the Status application is displayed in a tree view, with like items grouped into branches. Setup can be accessed as choice 9. from the Main Menu.

10.1 GPS

10.1.1 Position

The position screen provides coordinate information containing:

- Coordinate system toggle
- Current time
- X,Y coordinates
- Ellipsoidal Elevation (EHeight)
- Position and Height Quality

10.1.2 Satellite Information

The satellite information screen displays a tabular listing of the satellites that should be visible based on the current almanac and setup mask angle. Data in the table includes:

- Tracking status of the satellite (Check box)
- Satellite Number (Sat)
- Elevation above the horizon and information if the satellite is rising or falling. (^ = rising) (Elev)
- Azimuth (A)
- Signal to Noise Ratio, or strength of reception (SNR)

10.1.3 Satellite View

The satellite view provides a user friendly interface for viewing visible vs. tracked satellites. Satellites are displayed by their corresponding number. Tracked satellites appear highlighted with the satellite number inverted.

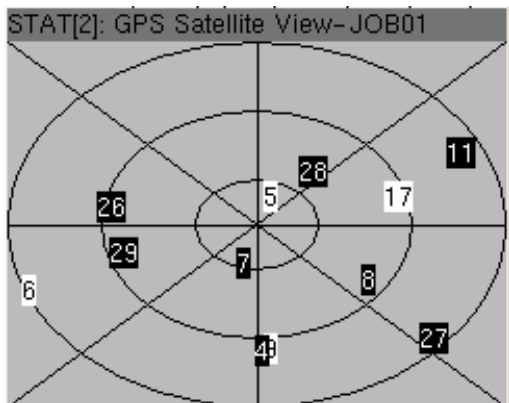

 The exterior ring represents the mask angle, the next interior ring is 45 degrees, and the most interior 60 degrees.

10.2 Interfaces

10.2.1 Real-Time

The real-time interface provides information about the RTCM corrections being received by the device. Interface data will be specific to the device being used, for example:

10.2.1.1 RTB Coast Guard Beacon

- Station ID
- Frequency
- Channel
- Bit Rate
- Signal Strength
- Signal to Noise Ratio (SNR)
- Correction Age
- % Correction Received

10.3 Hardware

The hardware screen displays information pertaining to

- Serial Number
- Firmware Version
- Total Available RAM (in bytes)
- Battery Level

11. Glossary

Almanac

Library of coarse satellite orbital data used to calculate satellite position, rise time, elevation, and azimuth.

ASCII

American Standard Code for Information Interchange, developed through the American National Standards Institute. ASCII is a scheme of binary notation for machine-readable data.

Attribute

A data field of a database, often defined by the type of string, integer, real-number or boolean.

Auxiliary points

A base or reference point used to collect an offset point or feature.

Azimuth

A horizontal angle measured clockwise from a direction (such as North)

Bluetooth

A non-proprietary wireless cable replacement.

Code

1. A template of a feature layer, containing information about the feature type and attribution.
2. C/A Code: The Coarse Acquisition GPS data message modulated on the L1 signal.

Coordinate Systems

The combination of an Ellipsoidal with a referenced angular or grid projection.

Course Azimuth

Azimuth of the GPS operators direction.

Course Velocity

Velocity of the GPS operator.

DGPS (Differential GPS)

A GPS system that utilizes differential code corrections to achieve an enhanced positional accuracy; usually 0.5-5 meters.

Differential Corrections

The determination of relative coordinates between the rover receiver from a reference receiver which are simultaneously tracking the same GPS signals.

Dilution of precision (DOP)

A description of the geometric contribution of uncertainty in a position fix.

EGNOS

European Geostationary Navigation Overlay Service

Ellipsoid

A mathematical figure formed by revolving an ellipse about its minor axis, used in geodesy to best fit the shape of the earth.

Ellipsoidal elevation

The vertical distance of a point above the ellipsoid.

ESTB

EGNOS Satellite Test Bed

Firmware

Embedded software that resides on a hardware device.

Geoid

An equipotential surface which coincides with mean sea level and extends everywhere, perpendicular with the force of gravity.

GIS (Geographic Information System)

Geographic Information System

GIS DataPRO

The office software used to interact between the Leica Geosystems GS20 and GIS and CAD packages.

GPS

Global Positioning System

GPS Time

A continuous time system based on the Coordinated Universal Time (UTC) from 6th January 1980.

Greenwich Mean Time

The mean solar time of the meridian of Greenwich. Used as the prime basis of standard time throughout the world.

HyperTrack

Leica's Trademark tracking technology created for areas with heavy canopy, for ex. Urban Canyons.

Job

A Leica Geosystems GS20 Project consisting of multiple filetypes.

Latitude

The angle between the ellipsoidal normal and the equatorial plane. Latitude is zero on the equator and 90° at the poles.

Loader

The software that loads the firmware into the hardware's system memory on boot.

Local Time

Local time equals GPS time + time zone.

Logging rate

The rate in which raw GPS data are written

Longitude

Longitude is the angle between the meridian ellipse which passes through Greenwich and the meridian ellipse containing the point in question.

Mask Angle

The minimum elevation angle below which no more GPS satellites are tracked by the receiver.

Max Accuracy (ClearTrack)

The tracking mode incorporating carrier phase smoothing with the highest discriminating tracking algorithms.

Max Track

Leica's Trademark tracking technology created for areas of heavy canopy.

Maximum Age of Correction

The amount of time a real-time correction will be used to adjust a GPS position, once the correction link is lost.

Meridian

An imaginary line joining north to south pole and passing through the equator at 90°.

Multipath Error

A positioning error resulting from interference between split radio waves which have travelled to the receiver from differing paths.

NMEA

National Marine Electronics Association. A standard originally defined to enable marine electronics instruments, communication, and navigation equipment to communicate.

Orthometric Height

The distance of a point above the geoid (or mean sea level). Ortho = Ellipsoid - Geoid.

PDOP

Positional dilution of precision. See DOP

Post-processing

The process of computing positions in non-real-time, using data previously collected by GPS receivers. See differential corrections.

Pseudo-range

A measure of the apparent signal propagation time from the satellite to the receiver antenna, scaled into distance by the speed of light. Pseudorange differs from the actual range by the influence of satellite and user clock.

Quality

A measure of precision calculated by residuals calculated using a 2D sigma (67% confidence)

Real-Time

A DGPS position calculated by correcting autonomous GPS with a differential correction.

RTCM

Radio Technical Commission for Maritime services. Commission set up to define differential data link to relay GPS messages from a monitor station to a field user.

SBAS

The Satellite Based Augmentation System is a free real-time correction for GPS available in several continents (see WAAS)

Selective Availability

Degradation of GPS point positioning accuracy for civilian users by the U.S. Department of Defense. SA is produced by clock dithering or orbit degradation.

Signal to Noise Ratio

A ratio of the radio frequency signal strength and the noise floor.

Time and Initial Position

The time and position value a GPS receiver will use with an almanac to more quickly locate satellites.

WAAS

The Wide Area Augmentation System (WAAS) is a free real-time correction for GPS available in North America, and is comparable to the European EGNOS correction, currently in a testing phase. Because this correction which is broadcast on the same frequency as GPS, it can be received without the need for additional hardware, and free of charge.

Waypoints

A point, or node on a line or area flagged for navigation.

12. Index

A		F		N	
Almanac	13, 88	Firmware	70	NMEA	89
ASCII	86	G		P	
Attribute	56	Geoid Field File	52	Paging	16
Auxiliary points	85	GIS DataPRO	70	Post Processing	88
Azimuth	34, 109	GPS	18	Pseudo-range	87
B		Greenwich Mean Time	108	Q	
Bluetooth	74	J		Quality	88
C		Job	19	R	
CFC	57	L		Real-Time	89
CFC Mask	57	Latitude	88	RTCM	89
Code	25	Loader	70	S	
Coordinate systems	49	Logging rate	88	SBAS	71, 93, 114
Course Azimuth	46	Longitude	88	Sensor	74
Course Velocity	46	M		Signal to Noise Ratio	109
Cultivated Field Control	57	Mask Angle	87	T	
D		Max Accuracy	87	Time and Initial Position	88
DGPS	12	Max Track	87	W	
Differential Corrections	13	Maximum Age of Correction	90	WAAS	71, 93, 114
DOP	87	Multiple functions		Waypoints	45
E		3	14		
Ellipsoidal Elevation	109	9	14		
Ellipsoidal elevation	87				

***Leica Geosystems AG, Heerbrugg,
Switzerland, has been certified as
being equipped with a quality system
which meets the International
Standards of Quality Management and
Quality Systems (ISO standard 9001)
and Environmental Management
Systems (ISO standard 14001).***



***Total Quality Management-
Our commitment to total
customer satisfaction.***

*Ask your local Leica dealer for
more information about our TQM
program.*

733607-2.0.0en

Printed in Switzerland - Copyright Leica Geosystems AG,
Heerbrugg, Switzerland 2005
Original text

Leica
Geosystems

*Leica Geosystems AG
CH-9435 Heerbrugg
(Switzerland)*

Phone +41 71 727 31 31

Fax +41 71 727 46 73

www.leica-geosystems.com