



**A BRIEF INTRODUCTION TO
INDUSTRIAL FURNACE COMPANY
AND
MULTIPLE HEARTH FURNACES**



Industrial Furnace Company, Inc

Founded as a refractory installation company in 1948
Quickly became specialized in the municipal waste incineration field.

Family owned since 1948, currently in 3rd generation.

Leading experts in Multiple Hearth Furnace design, construction, maintenance, operations, and rehabilitation

Engineering, technical consulting, refractory specialty, construction

Have serviced most of the MHF's in the U.S.

Expanded service into the privately owned, industrial market.

EXPERTISE AND AVAILABILITY

- ▣ Performed projects in:
 - 47 American States
 - Puerto Rico
 - Canada
 - Europe
 - Asia
 - Africa
 - South America
- ▣ Office and skilled field crew available 24/7
- ▣ Offices in NY and GA allow instant mobilization virtually anywhere



ENGINEERING AND DESIGN

- ▣ IFCO has a full in-house engineering staff
 - Also maintain excellent working relationships with several top engineering firms specializing in Fluid Beds and MHF Technologies.
- ▣ Designs completed with 3-D models and 2-D drawings
 - SolidWorks
 - AutoCAD

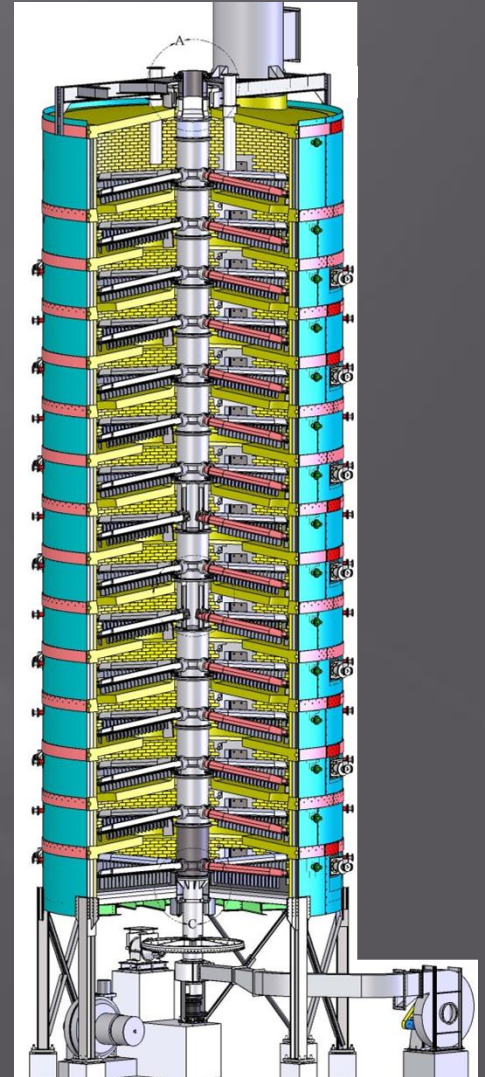

A SolidWorks Model of a 25'-9" x 15" Hearth MHF recently built by IFCO

MULTI-CRAFTED TRADESMEN



- We employ: Masons, ASME and AWS Certified Welders, Carpenters, Millwrights, Riggers, Scaffold Builders, Electricians, Integration Technicians, and Control and Instrumentation Technicians.
- Employees complete OSHA, MSHA, HAZWOPER Training, and IFCO Safety Training Courses to ensure a safe working environment
- UL listed Panel Shop

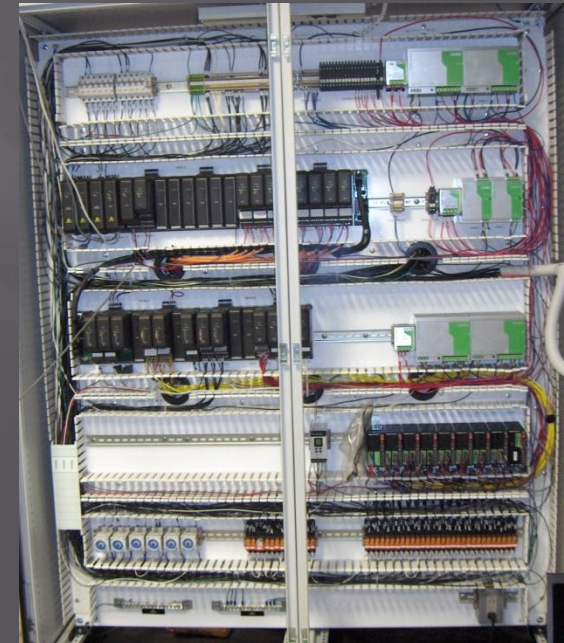

What is a Multiple Hearth Furnace?

- Most people have never heard of a Multiple Hearth Furnace
- Some people may refer to a Multiple Hearth Furnace as a “Multiple Hearth Incinerator,” a “Multiple Hearth Roaster,” “Retort Furnace,” “MHF,” or “MHI,” “Calciner,” among a myriad of similar or more specific names.
- A Multiple Hearth Furnace is usually employed when a large volume of material needs to be thermally processed, provided that the material is:
 - Moderately uniform in content
 - Steady, continuous feed

Definition

- A furnace consisting of several round, stacked hearths.
 - The hearths are basically floors within a large cylinder.
 - The hearths alternate between in-hearths and out-hearths.
 - In hearths have a large hole in the center, for material to pass through to the hearth below.
 - Out-hearths, have holes around the perimeter of the hearth for material to pass through to the hearth below.

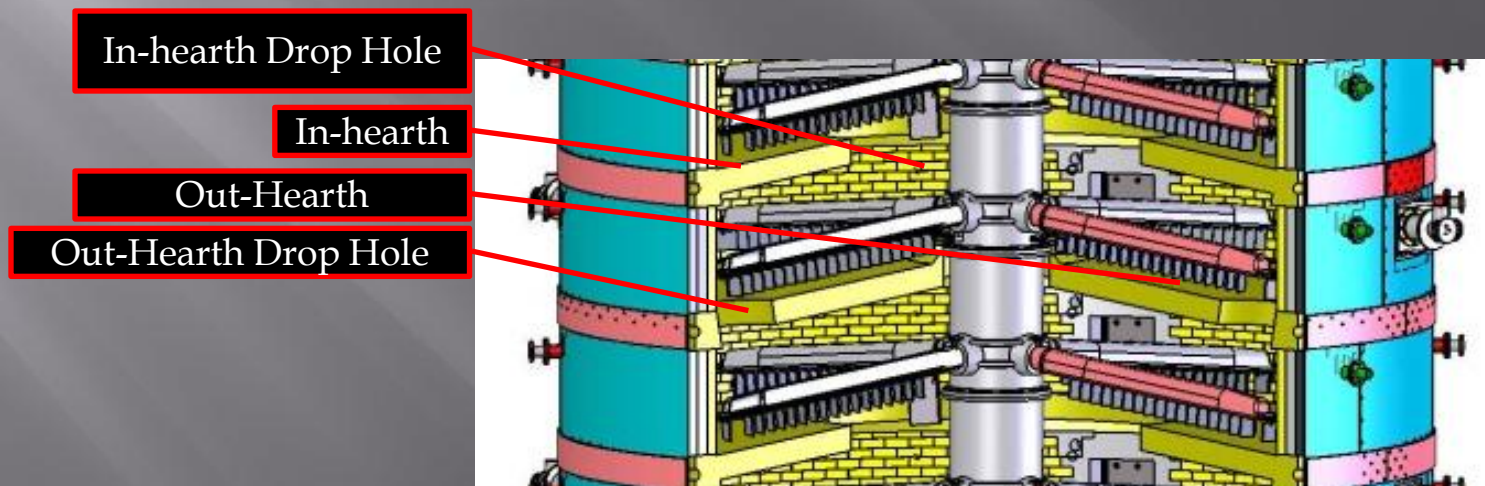

Construction

- ❑ Multiple Hearth Furnaces generally utilize a steel shell, with refractory lining.
- ❑ Skew Bands are used to support the hearths, and appear as rings on the outside of the shell.
- ❑ The refractory lining and hearths are generally made of bricks. The hearths are self supporting three dimensional sprung arches, and distribute all of their weight to the shell and skew band.



Two large MHFs under construction



A crew installing a new furnace wall lining and hearth. In this photo they are pouring a refractory burner tile.

Material Movement

Material is fed into the top of the furnace, and is moved down, from hearth to hearth, until it exits at the bottom.

Centershaft, Rabble Arms, Rabble Teeth

- The Centershaft is a vertical shaft through the furnace. It spins slowly. This turning swings the “Rabble Arms” which are holding “Rabble Teeth.”
- The Rabble Teeth plow the material across the hearths toward the drop holes.
- This rabbling action, stirs the material and exposes new material to the furnace atmosphere.

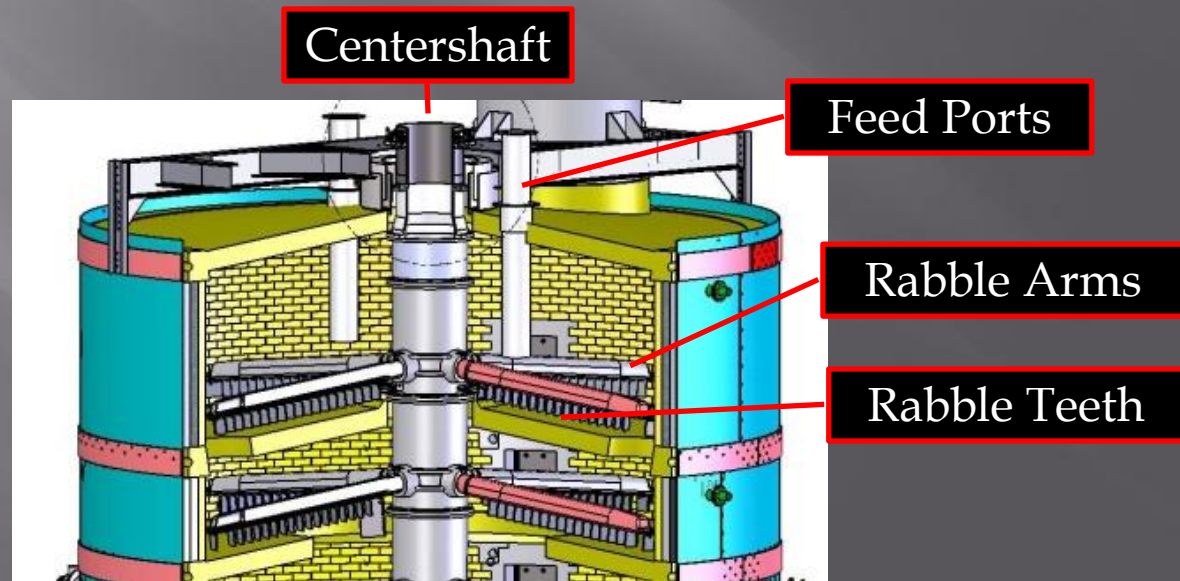

Material Movement

- ▣ Residence time can be varied based on:
 - Rabble Pattern. We can customize the rabble pattern to keep material on certain hearths for longer or shorter durations.
 - Centershaft speed. We can use a Variable Speed Drive on the centershaft to increase or decrease the speed depending on the process parameters.

Thermal System

- The Multiple Hearth Furnace can be operated at a wide range of temperatures. The hearths allow for zoning of the atmospheres, including temperatures.
- The energy to meet the desired temperature can come from the chemical process of the material, or from burners. Hearths can even be artificially cooled using air, mist, or steam injection.
- Multiple Hearth Furnaces use burners to heat the furnace, and dry-out the refractory before feed is initiated. Then burners are used to maintain temperatures as needed.
- The burners can burn any fuel. Most common are fossil fuels (Natural Gas, Propane, Oil) but other fuel sources are possible.

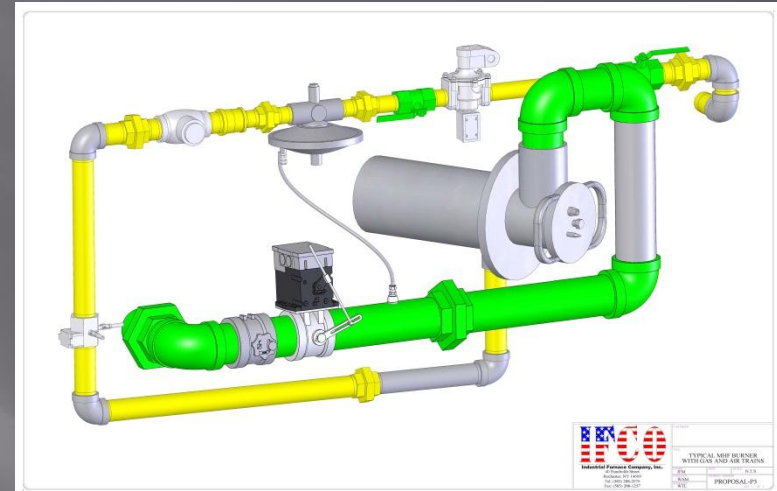

MHF BURNER AND BURNER TRAIN
THIS WAS DESIGNED TO FIT AN EXISTING VERY
TIGHT LOCATION

INSTRUMENTATION AND CONTROLS

- Multiple Hearth Furnaces can be built, or rebuilt with state-of-the-art control systems. Advanced Process Controls can be used to optimize the system for maximum product yield, product quality, and fuel savings.
- Control packages can be customized to give the customer a fully automated machine, to a basic package that requires manual intervention at every step.
- All systems can be automated. The most common automation is the temperature, which is usually controlled by the burners.

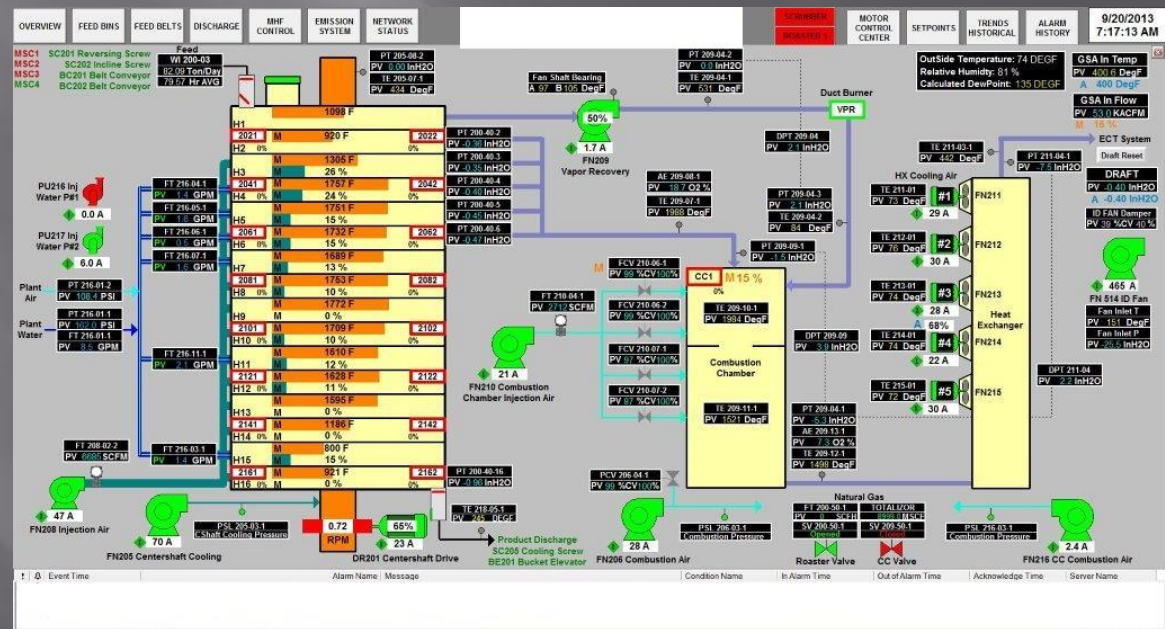

Benefits of an MHF

- Multiple Hearths = Multiple Zones
 - The material can go through separate stages, such as drying, devolatilizing, calcining, reduction, oxidization...
 - With careful control, and proper I&C each zone can be closely monitored and the proper atmosphere can be maintained in each zone.
- Production Rates and Quality
 - Because the process can be so closely monitored, maximum production and quality rates can be achieved.
- Energy Usage
 - Many processes can be run autogenously; reducing or eliminating fuel usage.
 - Relatively low horsepower requirements for fans and centershaft.
- Turn Down
 - While an MHF “prefers” constant feed. Many processes allow for a wide turn-down ratio without loss of efficiency. Some competing technologies suffer greatly when product feed does not meet the design criteria.
- Reduced Floor Space Requirement
 - Because the hearths are stacked, a larger furnace can be installed in less space. A choice of diameters can make the space savings significant. Some of our competition requires significantly more floor space to approach the capacity easily achieved with an MHF.
 - MHFs can be raised on legs to accommodate material handling equipment underneath the furnace, such as ash handling equipment, or even discharging directly into another process furnace.
- Low Maintenance Requirements
 - Multiple Hearth Furnaces are designed and built to be run year round with minimal internal maintenance, meaning fewer shut-downs. Some customers even mortar the doors shut because they hardly ever need to open them.
 - The fans and motors are generally smaller, requiring less maintenance.

Known Processes for Multiple Hearth Furnaces

- ▣ Activated Carbon Production
- ▣ Alumina, Reacted
- ▣ Ammonia Sulfate Drying
- ▣ Antimony Sulfide
- ▣ Arsenical Speiss
- ▣ Arsine Removal (Tin Smelter)
- ▣ Bactrigester
- ▣ Bauxite Revivication
- ▣ Beryllium Hydroxide
- ▣ Bone Char Regeneration
- ▣ Carbon Black Sludge
- ▣ Carbon Regeneration
- ▣ Cement Calcining
- ▣ Charcoal
- ▣ Chip Deoiling
- ▣ Chloridizing Roast
- ▣ Clay
- ▣ Clay Calcining
- ▣ Clay Granules
- ▣ Coke Calcining
- ▣ Concentrates Drying
- ▣ Copper Powder Processing
- ▣ Copper Roasting
- ▣ Cryolite (Processing)
- ▣ Delacquering Metal Chips
- ▣ Diatomaceous Earth
- ▣ Diatomaceous Earth-Regeneration or Recovery
- ▣ Direct Reduction of Iron (D.R.I.)
- ▣ Dolomite
- ▣ Gold Chloridizing
- ▣ Granules
- ▣ Industrial Carbon Regeneration
- ▣ Iron Oxide
- ▣ Iron Powder (Processing)
- ▣ Iron (Sponge)
- ▣ Kaolin Clay Calcining
- ▣ Lead-Acid Batteries-separator recycling
- ▣ Lead Sulfate
- ▣ Lime Calcination or Recalcination
- ▣ Litharge
- ▣ Lithium Concentrate
- ▣ Magnesium Oxide
- ▣ Magnetite Ore (Red)
- ▣ Manganese
- ▣ Mercury (Processing)
- ▣ Molybdenum
- ▣ Molybdenum Concentrates Drying
- ▣ Molybdenum Concentrates Processing
- ▣ Monohydrate Mercuric Nitrate
- ▣ Monohydrating
- ▣ Nickel Catalyst
- ▣ Nickel Roasting
- ▣ Oil Sludge Incineration
- ▣ Perlite
- ▣ Petroleum Coke
- ▣ Refinery Waste/ Sludge Incineration
- ▣ Sand (Foundry) Reclamation
- ▣ Selenium
- ▣ Sewage Sludge Incineration
- ▣ Silver Slimes
- ▣ Silver Slimes-Drying and Desulfurizing
- ▣ Soda Ash
- ▣ Stannite Desulfurizing
- ▣ Streptomycin Calcination
- ▣ Sulfate Drying
- ▣ Sulfur
- ▣ Sulfuric Acid Production (Pyrites Roasting)
- ▣ Telluride
- ▣ Tungsten Carbide Recycling
- ▣ Tungsten Concentrates
- ▣ Uranium- Yellow Cake Drying/ Caclining
- ▣ Vanadium Capture From Filter Media
- ▣ Zinc

New Processes are Being Tested All the Time!

- ▣ Our test furnace is available to test your process to determine suitability, and viability.
- ▣ See if a Multiple Hearth Furnace can improve your current process.



More Multiple Hearth Furnace Pictures

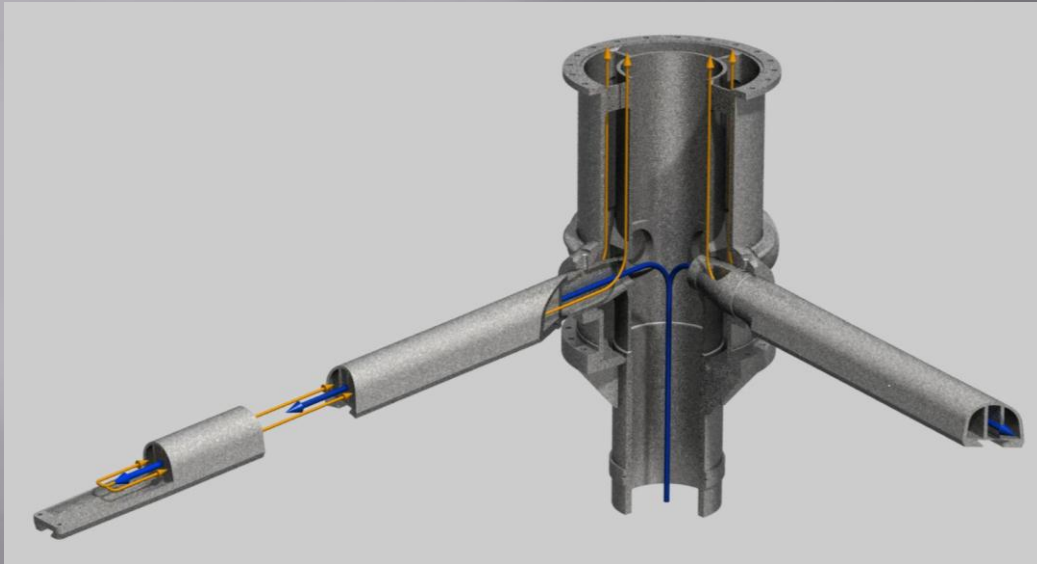

This rendering shows the cooling air going up through the centershaft, and cooling the rabble arms. Clean, warm air is discharged at the top of the furnace, and can be used for other processes, or returned to the furnace as pre-heated air, if needed.



More Multiple Hearth Furnace Pictures

In Hearth Drop Hole

Centershaft

Rabble Arm

Rabble Teeth

Out Hearth



This photo shows an "Out Hearth" Visible are the Centershaft, Rabble Arm and Rabble Teeth, as well as an In and an Out Hearth.

More Multiple Hearth Furnace Pictures

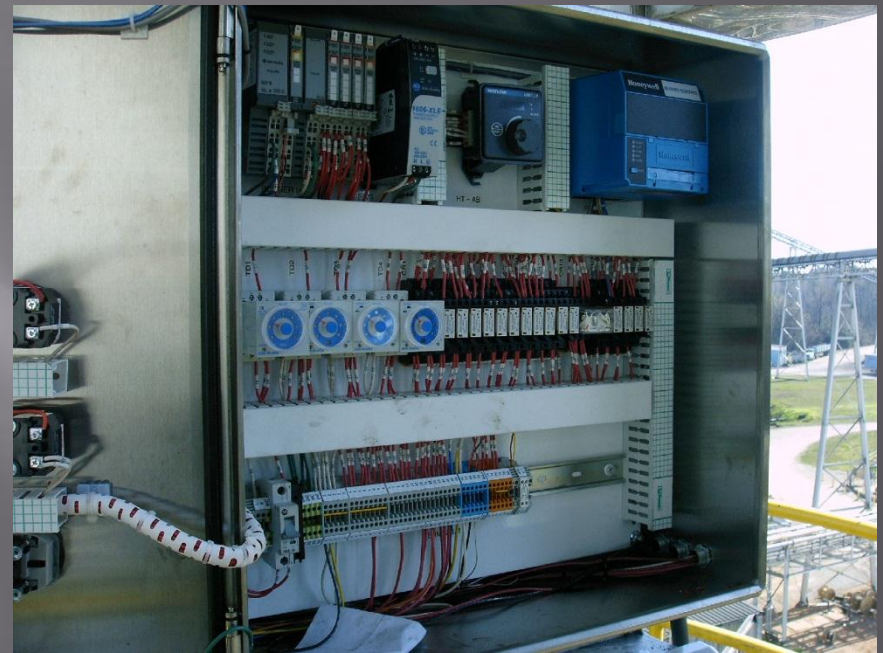

Left: Our crew puts the finishing touches on a recently constructed furnace.

Above: The inside of a burner control panel. Each burner has an individual control panel and can be run locally or remotely.