



Johnson/Evinrude Model Identification

Outboards 1980-1998

Model Variation	Style	Horse-power	Design Feature	Shaft Length	Year Built
A = Australia B = Belgium C = Canada H = Hong Kong S = South Africa T = Tracker V = Boat Builder	J = Johnson E = Evinrude C = Commercial V = Quiet Rider	Example: 20 40 200	AE = Elec. Start - Alaska AR = Rope Start - Alaska BA = AC Lighting - Rope Start BE = Belgium Derated - Elec. Start BF = Belgium Derated - Rope Start BG = Belgium Derated - Rope Start BI = Belgium Derated - Rope Start BR = Euro Rope Start C = Counter Rotation CE = Canada Derated - Elec. Start CR = Canada Derated - Rope Start D = Remote Electric DE = Derated - Elec. Start DR = Derated - Rope Start DT = Derated - Elec. Start/Trim & Tilt E = Elec. Start ER = Elec. Start - Sport Styling ES = Elec. Start - Special FA = 4-stroke - Rope Start FE = 4-stroke - Elec. Start/Remote FP = Commercial w/Program Tilt FR = 4-stroke - Rope Start FRE = 4-stroke - Elec. Start/Remote FS = FICHT - Trim & Tilt FT = FICHT - Trim & Tilt/Special Styling G = Special Styling H = Less Integral Tank/Hydraulic Steering I = FICHT Fuel Injection IE = Italy Elec. Start IK = Italy Elec. Start J = Jet Drive K = 3-CYL 25/35 KC = Kerosene Rope Start KG = Kerosene/Gasoline KS = Kerosene Rope Start M = Manual Tilt - Elec. Start MS = Manual Tilt - Elec. Start/Special N = Counter Rotation P = Power Steering Q = 3-CYL 25/35 Trim & Tilt R = Rope Start RA = Australia Rope Start RC = Rope Start - Commercial/CD Ignition RD = Rope Start - Deluxe RE = Remote Elec. RP = Commercial w/Program Tilt RS = Rope Start - Commercial RW = Commercial w/Program Tilt S = Sail - Special Styling SC = Special Styling/Counter Rotation SE = Elec. Start Non-Tilt Sail SI = Italy Special Derated SL = 60 Degree V - Trim & Tilt SP = Special Styling SR = Rope Start - Sail - Non-Tilt ST = Special Styling - Trim & Tilt T = Trim & Tilt - Elec. Start TE = Tiller Elec. TR = Trim & Tilt - Sport styling TT = Tiller - Trim & Tilt U = Manual Tilt V = Special Gearcase W = 110 Degree Angle Drive - Rope Start WM = Elec. Commercial - Manual Tilt WMP = Same as "WM" w/Chrome Pump WT = Elec. Commercial - Trim & Tilt WTP = Same as "WT" w/Chrome Pump	= 15" L = 20" Y = 22.5" X = 25" Z = 30"	I = 1 N = 2 T = 3 R = 4 O = 5 D = 6 U = 7 C = 8 E = 9 S = 0 EX: CS = 1980 ES = 1990 EU = 1997 SC = 2008

EXAMPLE: VE70TLEDA - Boat Builder Model, Evinrude, 70 HP, Trim & Tilt w/Elec. Start, 1996 Model

MODEL IDENTIFICATION CHART CONTINUED ON NEXT PAGE

OUTBOARD

Johnson/Evinrude Model Identification

Outboards 1999 and Newer

Style	Horse-power	Design Feature	Shaft Length	Year Built
J = Johnson E = Evinrude	Example: 20 40 200	3 = 3-CYL (25 or 35 HP) 4 = Four Stroke Engine B = Blue Paint C = Counter-Rotation w/Trim & Tilt D = E-TEC E = Electric Start w/Remote Steering F = FICHT Fuel Injection G = Graphite Paint J = Jet M = Military Model P = Power Trim & Tilt R = Rope Start w/Tiller Steering S = Special Styling (White Evinrude) T = Tiller Steering TE = Tiller Electric W = Commercial Model	= 15" L = 20" Y = 22.5" X = 25" Z = 30"	I = 1 N = 2 T = 3 R = 4 O = 5 D = 6 U = 7 C = 8 E = 9 S = 0 EX: EE = 1999 SC = 2008

EXAMPLE: E70PLEEA - Evinrude model, 70 HP, Power Trim&Tilt, 20", 1999 model

 <p>18-5001 TUNE-UP KIT Replaces: 172525 — CONTAINS —</p> <table border="1"> <thead> <tr> <th>Part #</th> <th>Desc.</th> <th>O.E.#</th> <th>Qty.</th> </tr> </thead> <tbody> <tr> <td>18-5200</td> <td>Condenser</td> <td>580256</td> <td>1</td> </tr> <tr> <td>18-5157</td> <td>Contact set</td> <td>580290</td> <td>2</td> </tr> </tbody> </table>	Part #	Desc.	O.E.#	Qty.	18-5200	Condenser	580256	1	18-5157	Contact set	580290	2	 <p>18-5002D TUNE-UP KIT Replaces: 172523 — CONTAINS —</p> <table border="1"> <thead> <tr> <th>Part #</th> <th>Desc.</th> <th>O.E.#</th> <th>Qty.</th> </tr> </thead> <tbody> <tr> <td>18-5205</td> <td>Condenser</td> <td>581419</td> <td>2</td> </tr> <tr> <td>18-5156</td> <td>Contact Set</td> <td>580148</td> <td>2</td> </tr> </tbody> </table>	Part #	Desc.	O.E.#	Qty.	18-5205	Condenser	581419	2	18-5156	Contact Set	580148	2	 <p>18-5003D TUNE-UP KIT Replaces: 172806 — CONTAINS —</p> <table border="1"> <thead> <tr> <th>Part #</th> <th>Desc.</th> <th>O.E.#</th> <th>Qty.</th> </tr> </thead> <tbody> <tr> <td>18-5205</td> <td>Condenser</td> <td>581419</td> <td>2</td> </tr> <tr> <td>18-5141</td> <td>Contact Set</td> <td>581207</td> <td>2</td> </tr> </tbody> </table>	Part #	Desc.	O.E.#	Qty.	18-5205	Condenser	581419	2	18-5141	Contact Set	581207	2
Part #	Desc.	O.E.#	Qty.																																			
18-5200	Condenser	580256	1																																			
18-5157	Contact set	580290	2																																			
Part #	Desc.	O.E.#	Qty.																																			
18-5205	Condenser	581419	2																																			
18-5156	Contact Set	580148	2																																			
Part #	Desc.	O.E.#	Qty.																																			
18-5205	Condenser	581419	2																																			
18-5141	Contact Set	581207	2																																			
 <p>18-5006D TUNE-UP KIT Replaces: 172522 — CONTAINS —</p> <table border="1"> <thead> <tr> <th>Part #</th> <th>Desc.</th> <th>O.E.#</th> <th>Qty.</th> </tr> </thead> <tbody> <tr> <td>18-5199</td> <td>Condenser</td> <td>580321</td> <td>2</td> </tr> <tr> <td>18-5156</td> <td>Contact Set</td> <td>580148</td> <td>2</td> </tr> </tbody> </table>	Part #	Desc.	O.E.#	Qty.	18-5199	Condenser	580321	2	18-5156	Contact Set	580148	2	 <p>18-5011D TUNE-UP KIT Replaces: 172521 — CONTAINS —</p> <table border="1"> <thead> <tr> <th>Part #</th> <th>Desc.</th> <th>O.E.#</th> <th>Qty.</th> </tr> </thead> <tbody> <tr> <td>18-5199</td> <td>Condenser</td> <td>580321</td> <td>1</td> </tr> <tr> <td>18-5156</td> <td>Contact Set</td> <td>580148</td> <td>1</td> </tr> </tbody> </table>	Part #	Desc.	O.E.#	Qty.	18-5199	Condenser	580321	1	18-5156	Contact Set	580148	1	 <p>18-5141 CONTACT SET Replaces: 581207</p>												
Part #	Desc.	O.E.#	Qty.																																			
18-5199	Condenser	580321	2																																			
18-5156	Contact Set	580148	2																																			
Part #	Desc.	O.E.#	Qty.																																			
18-5199	Condenser	580321	1																																			
18-5156	Contact Set	580148	1																																			
 <p>18-5156 CONTACT SET Replaces: 580148</p>	 <p>18-5157 CONTACT SET Replaces: 580290</p>	 <p>CONDENSER 18-5199 18-5205 Replaces: 580321 Replaces: 581419</p>	 <p>18-5200 CONDENSER Replaces: 580256</p>																																			

OUTBOARD

APPLICATION BEGINS ON NEXT PAGE

① Items ending in "D" are Display Packaged - Regular number is Non-Display

JOHNSON/EVINRUDE (OMC/BRP)

Ignition System



HP	YEARS	CONTACT SET	CONDENSER	TUNE-UP KIT	HP	YEARS	CONTACT SET	CONDENSER	TUNE-UP KIT
1.5/2	1968-90	18-5156	18-5199	18-5011	28	1962-64	18-5156	18-5205	18-5002
3	1952-68	18-5156	18-5199	18-5006	30	1956	18-5156	18-5199	18-5006
4	1965-76,1981-90	18-5156	18-5199	18-5006	33	1965-70	18-5156	18-5205	18-5002
5	1965-68	18-5156	18-5199	18-5006	35	1958-59	18-5156	18-5199	18-5006
5.5	1954-64	18-5156	18-5199	18-5006	35	1976	18-5141	18-5205	18-5003
6	1965-76	18-5156	18-5199	18-5006	40	1960-61	18-5156	18-5199	18-5006
7.5	1956-58	18-5156	18-5199	18-5006	40	1962-73	18-5156	18-5205	18-5002
9.5	1964-73	18-5156	18-5199	18-5006	40	1974-76	18-5141	18-5205	18-5003
9.9/15	1974-76	18-5141	18-5205	18-5003	40COMM	1981-83	18-5141	18-5205	18-5003
10	1950-63	18-5156	18-5199	18-5006	45/50	1958-59	18-5157	18-5200	18-5001
15	1956	18-5156	18-5199	18-5006	60	1964-67	18-5157	18-5200	18-5001
18	1957-61	18-5156	18-5199	18-5006	75/80	1960-67	18-5157	18-5200	18-5001
18/20	1962-73	18-5156	18-5205	18-5002	90	1964-75	18-5157	18-5200	18-5001
25	1969-76	18-5156	18-5205	18-5002	100	1966	18-5157	18-5200	18-5001
25	1955	18-5156	18-5199	18-5006					

③ Colt and Jr.



18-5163
IGNITION COIL
Replaces: 581130



18-5170
IGNITION COIL
Replaces: 583740



18-5172
IGNITION COIL
Replaces: 581786



18-5176
IGNITION COIL KIT
Replaces: 582366,
583737, 584561



18-5179
IGNITION COIL
Replaces: 582508



18-5181
IGNITION COIL
Replaces: 582995, 584477



18-5192
IGNITION COIL
Replaces: 582091



18-5193
IGNITION COIL
Replaces: 582382



18-5194
IGNITION COIL
Replaces: 582160, 584632



18-5196
IGNITION COIL
Replaces: 581407, 502880

APPLICATION BEGINS ON NEXT PAGE

① Items ending in "D" are Display Packaged - Regular number is Non-Display



JOHNSON/EVINRUDE (OMC/BRP) Ignition System

H.P.	YEARS	COIL	QTY.	H.P.	YEARS	COIL	QTY.
1.5,2, Colt,Jr.	1968-90	18-5181	1	55 Comm.	1985-92	18-5179	2
2,2.3,3.3	1995-99	18-5170	1	60	1978-84	18-5176	2
2.5	1988	18-5170	1	60	1985-01	18-5179	3
2.5 Ultra/Excel	1987-88	18-5170	1	60 SST	1989-90	18-5179	3
3, 4	1950-76	18-5181	2	3 Cyl. Thru V-8	1985-99	18-5179 ⑥	per cyl
3,4	1991-01	18-5170	1	65	1971-75	18-5194	3
4	1981-89	18-5181	1	65	1979-84	18-5176	3
4	1977-80	18-5176	1	65 Comm.	1985-01	18-5179	3
4 Deluxe	1985-99	18-5179	2	70, 75	1974-75	18-5194	3
4 Ultra/Excel	1987-90	18-5170	1	70	1979-84	18-5176	3
4.5, 6, 7.5, 8	1980-84	18-5176	2	70	1985-01	18-5179	3
4.5	1986-87	18-5179	2	75	1979-84	18-5176	3
5, 5.5, 6	1950-76	18-5181	2	75	1985-99	18-5179	3
5	1985-91	18-5179	2	85	1969-72	18-5193	1
6	1977-84	18-5176	2	85	1973-75	18-5194	4
6, 8	1985-90	18-5179	2	85, 115	1976-77	18-5192	4
6,8	1991-99	18-5170	1	85	1978-84	18-5176	4
6.5 Comm.	1989-90	18-5179	2	85	1985-95	18-5179	4
7.5	1954-58	18-5181	2	88	1987-96	18-5179	4
9.5	1964-73	18-5181	2	90	1978-84	18-5176	4
9.9/15	1974-76	18-5196	2	90	1985-94	18-5179	4
9.9/15	1977-84	18-5176	2	90,115 Looper	1995-99	18-5170	2
9.9/15	1985-92	18-5179	2	100	1971-72	18-5193	1
9.9,15	1993-99	18-5170	1	100	1978-84	18-5176	4
9.9/15 4-Stroke	1994-99	18-5176	2	100	1985-99	18-5179	4
10	1949-63	18-5181	2	110	1986-90	18-5179	4
10,14 Comm.	1989-90	18-5176	2	115	1969-70	18-5193	1
14	1988	18-5176	2	115	1973-74	18-5194	4
15, 18, 20, 25	1951-72	18-5181	2	115	1978-84	18-5176	4
18,20	1973	18-5172 ③	2	115	1985-99	18-5179	4
18,20	1973	18-5163 ③	1	120	1985-99	18-5179	4
20, 25, 30	1985-99	18-5179	2	125	1971-72	18-5193	1
25	1973-76	18-5172 ③	2	125	1991-99	18-5179	4
25	1973-76	18-5163 ③	1	125 Comm.	1989-99	18-5179	4
25	1977-84	18-5176	2	135	1973-75	18-5194	4
25 Comm.	1985-91	18-5179	2	135	1976	18-5192	4
28, 30, 33, 35	1956-70	18-5181	2	140	1977	18-5192	4
28	1987-88	18-5176	2	140	1978-84	18-5176	4
28 ⑦	1989-90	18-5179	2	140	1985-99	18-5179	4
28	1997-98	18-5170	2	150, 175, 200, 235	1976-78	18-5192	1
30	1977-84	18-5176	2	150	1979-84	18-5176	6
35	1976	18-5172	2	150	1985-99	18-5179 ⑥	6
35	1977-84	18-5176	2	150-175 V6 EFI	1997-98	18-5170	3
40	1960-73	18-5181	2	150-175 Looper	1991-99	18-5170	3
40	1974	18-5196	2	155 Comm.	1984-99	18-5179 ①	6
40	1975-83	18-5172 ②	2	175	1979-84	18-5176	6
40	1977-84	18-5176	2	175	1985-99	18-5179 ⑥	6
40 Thru 50, 2 Cyl.	1985-88	18-5179	2	185	1984-99	18-5179	6
40 Comm.	1985-90	18-5179	2	200	1979-84	18-5176	6
40 Thru 50, 2 Cyl.	1989-99	18-5170	1	200	1985-99	18-5179	6
45 Comm.	1985-92	18-5179	2	225	1986-99	18-5179	6
45 SS	1987-90	18-5179	2	235	1979-84	18-5176	6
48 ⑦	1987-88	18-5179	2	250	1991-99	18-5179	8
45	1989-96	18-5170	2	275	1985-99	18-5179	8
50	1971-75	18-5194	2	300,3.6	1985-99	18-5179	8
50	1978-84	18-5176	2	Sail Drive	1978-99	18-5176	2
50	1985-88	18-5179	2	Sea Drive	1984-85	18-5176 ⑤	2
55	1978-84	18-5176	2				

- ① Except loopers
- ② Contact controlled engines only
- ③ (2) 18-5172 and (1) 18-5163 required per engine

- ⑤ Plug In Coil Only
- ⑥ Except 150-175 Loop
- ⑦ Except SPL models

OUTBOARD

JOHNSON/EVINRUDE (OMC/BRP)

Ignition System



18-5748
PULSE PACK
Replaces: 398362
Replacement of ignition coil is recommended



18-5749
AMPLIFIER
Replaces: 397123
Replacement of ignition coil is recommended



18-5753
POWER PACK
Replaces: 581731
(pack 4)



18-5754
POWER PACK
Replaces: 581726
(pack 3)



18-5755
POWER PACK
Replaces: 581397
(pack 2)



18-5756
POWER PACK
Replaces: 582056
Same as 18-5753
w/o Hardware Pack
(1) Hole Drilled



18-5757
POWER PACK
Replaces: 582057
Same as 18-5754
w/o Hardware Pack
(2) Holes Drilled



18-5758
POWER PACK
Replaces: 582453, 583380, 582452



18-5759
POWER PACK
Replaces: 582125



18-5760
POWER PACK
Replaces: 582138, 582400,
582642, 582556



18-5761
POWER PACK
Replaces: 583114



18-5762
POWER PACK
Replaces: 582115

APPLICATION BEGINS ON PAGE 165

OUTBOARD













 <p>18-5763 POWER PACK Replaces: 582285, 583170</p>	 <p>18-5764 POWER PACK Replaces: 582261</p>	 <p>18-5765 POWER PACK Replaces: 396141</p>
 <p>18-5766 POWER PACK Replaces: 583748</p>	 <p>18-5767 POWER PACK Replaces: 584783</p>	 <p>18-5768 POWER PACK Replaces: 584908, 5001344</p>
 <p>18-5770 POWER PACK Replaces: 584028</p>	 <p>18-5771 POWER PACK Replaces: 584032</p>	 <p>18-5772 POWER PACK Replaces: 584041</p>
 <p>18-5773 POWER PACK Replaces: 584642</p>	 <p>18-5774 POWER PACK Replaces: 585145</p>	 <p>18-5780 POWER PACK Replaces: 585189</p>

JOHNSON/EVINRUDE (OMC/BRP)

Ignition System



OUTBOARD

 <p>18-5782 POWER PACK Replaces: 582705</p>	 <p>18-5783 POWER PACK Replaces: 582811</p>	 <p>18-5784 POWER PACK Replaces: 583110</p>	 <p>18-5785 POWER PACK Replaces: 585261</p>
 <p>18-5794 POWER PACK Replaces: 584489, 584329, 583896, 584331</p>	 <p>18-5883 POWER PACK Replaces: 584488</p>	 <p>18-5885 POWER PACK Replaces: 583865 For: V-6 5800 rpm limit</p>	
 <p>18-5886 POWER PACK & SENSOR Replaces: 436367, 584122 For: V-6 engines with optical sensor</p>	 <p>18-5887 POWER PACK Replaces: 584985 For: V-6 engines with optical sensor</p>	 <p>18-5891 POWER PACK Replaces: 583605 For: 3 & 6 cyl. 6700 rpm limit</p>	
 <p>18-5892 POWER PACK Replaces: 582262 For: V-4 & V-8 6700 rpm limit</p>	 <p>18-5884 OPTICAL SENSOR Replaces: 586343 For: V-4 & V-6 engines</p>	 <p>18-9802 TIMING LIGHT <i>Self-powered accurate up to 10,000 RPM's</i></p>	

APPLICATION ON NEXT PAGE



JOHNSON/EVINRUDE (OMC/BRP)

Ignition System

Model	Years	Power Pack	Model	Years	Power Pack	Model	Years	Power Pack
4	1977-80,1984	18-5758	40	1985	18-5765	90	1988	18-5892
4	1993	18-5883	40	1986-88	18-5763	100	1971	18-5749
4 DLX	1986-88, 1994-99	18-5763	40	1991-93	18-5794	100	1968,1972	18-5748
4.5	1980-84	18-5758	40			100	1979-80	18-5759 ①
4.5	1986-87	18-5763	Rope Start	1993- 01	18-5768	100	1988	18-5892
5	1984	18-5758	40			100, 115	1989-99 Crossflow	18-5770
5	1985	18-5765	Electric Start	1993- 01	18-5785	110		
5	1986-88, 1993-98	18-5763	40 COM.	1986-88	18-5764 ⑦	(TCLDF only)	1986	18-5783
6	1977-79,1984	18-5758	45	1991-92	18-5794	110	1986-87	18-5784
6	1985	18-5765	48	1987-88	18-5763	110	1988	18-5892
6	1986-88, 1993-01	18-5763	48	1991-93	18-5794	115	1969-70	18-5748
6.5COM.	1992-99	18-5763	50	1971-75	18-5755	115	1973-77	18-5753 ②
7.5	1980-83	18-5758	50	1979,1981-84	18-5758	115	1978-84	18-5759 ①
8	1993-95	18-5763	50	1985	18-5765	115	1985	18-5783
9.9,15	1977-84	18-5758	50	1986-88	18-5763	120	1986	18-5892
9.9,15	1985	18-5765	50 Rope Start	1991-93	18-5794	120	1988-99	18-5772
9.9,15	1986-88	18-5763	50	1991-93	18-5794	120	1988-99	18-5772
9.9,15	1993-99	18-5767 ②	Electric Start	1993- 01	18-5785	125	1971-72	18-5748
10/15COM.	1992	18-5763	50 (3 cyl)	1996-99	18-5780 ⑧	130	1988-99	18-5772
10,15COM.	1993-99	18-5767	55	1976-77	18-5755	135	1973-76	18-5753 ②
20	1981-84	18-5758	55	1978-82	18-5758	140	1977	18-5753 ②
20	1985	18-5765	55	1991-92	18-5794	140	1978-83	18-5759 ①
20	1986-88	18-5763	60	1970-71	18-5749	140	1986	18-5892
20	1989-92	18-5794	60	1980-84	18-5758	140	1988-99	18-5772
20	1993-95	18-5768	60	1985	18-5765	150	1979-84	18-5760① ⑤
20	1996-01	18-5768 ⑩	60	1986-88	18-5763	150	1991-92	18-5886 ①
25	1977-84	18-5758 ④	60	1985	18-5765	150	1993-03	18-5887
25	1985	18-5765	60	1986-88	18-5762 ⑧	150,		
25	1986-88	18-5763	60	1989-92	18-5766	155 COM.	1986-88	18-5761
25	1989-92	18-5794	60	1993-95	18-5774 ⑧	150	1989-91	18-5885
25	1993-95	18-5768	60	1996-99	18-5780 ⑧	155	1989-92	18-5885
25	1996-01	18-5768 ⑩	65	1972-73	18-5754 ③	175	1977-78	18-5754③ ①
25 COM.	1986-88	18-5764 ⑦	65	1989-92	18-5766	175	1979-83	18-5760 ①
28	1986-88	18-5763	65	1993-95	18-5774 ⑧	175	1986-88	18-5761
28	1989-92	18-5794	70	1974-78	18-5754 ③	175	1989-91	18-5885
28	1996-01	18-5768	70	1979-84	18-5760	175	1991-92	18-5886 ①
30	1984	18-5758	70	1985	18-5782 ⑧	175	1993-03	18-5887
30	1985	18-5765	70	1986-88	18-5762 ⑧	185	1984	18-5760 ①
30	1986-88	18-5763	70	1989-92	18-5766	200	1976-78	18-5754③ ①
30	1989-92	18-5794	70	1993-95	18-5774 ⑧	200	1979-83	18-5760 ①
30	1993-95	18-5768	70	1996-99	18-5780 ⑧	200	1987	18-5891
30	1996-01	18-5768 ⑩	75	1975-78	18-5754 ③	225	1987	18-5891
35	1977-84	18-5758	75	1979-84	18-5760	235	1978	18-5754③ ①
35	1985	18-5765	75	1985	18-5782 ⑧	235	1979-84	18-5760 ①⑤⑥
35	1986-88	18-5763	75	1986-88	18-5762 ⑧	275	1986-87	18-5892
35	1989-92	18-5794	85	1969-72	18-5749	300	1987	18-5892
35	1993-95	18-5768	85	1973-77	18-5753 ②	V-8	1993-99	18-5773
35	1996-01	18-5768 ⑩	85	1978-80	18-5759 ①	1.6L	1984 & prior	18-5759 ⑨
40	1982	18-5758	88, 90	1986-87	18-5784	1.6L	1985	18-5782
			88	1988	18-5892	1.6L	1986-87	18-5784
			88,90	1989-99 Crossflow	18-5770	2.0L	1988-99	18-5772
			90	1981-83	18-5759 ①	2.5, 2.6L	1986-88	18-5761 ⑨
			90	1985	18-5783			

- ① 2 Power Packs required per engine
- ② Order 18-5756 for Power Pack w/o cover,insulated pad and mounting screws
- ③ Order 18-5757 for Power Pack w/o cover,insulated pad and mounting screws

- ④ All Models except Worktwin, Workhorse and Commercial Model for 1983
- ⑤ Port side only for 1983 model STLCT
- ⑥ Port side only for 1984 models with suffix beginning with "S"
- ⑦ 2 cyl. only

- ⑧ 3 cyl. only
- ⑨ Sea Drive Series
- ⑩ Except remote models
- ① Refer to picture
- ② For 2 stroke models only

OUTBOARD

PREMIUM MARINE SPARK PLUG WIRE LEADS

MAGFORCE™



OE style boots provide a sealed barrier against heat, dirt and moisture.

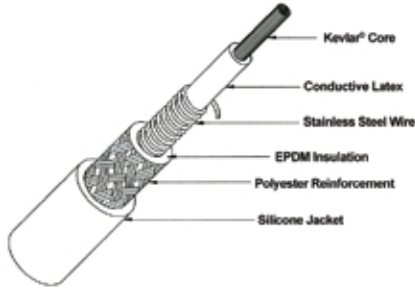

Premium Marine Wire Leads

*Magnetic Suppression Core
Manufactured for your
specific application*

- ★ Kevlar® core for maximum durability and long life.
- ★ Durable stainless steel wound conductor for maximum horsepower and engine performance.
- ★ Premium silicone jacketing and boots for the ultimate in high temperature protection.
- ★ Superior RFI suppression for the most sensitive electronic system.
- ★ Corrosion resistant stainless steel spark plug and distributor terminals for maximum conductivity.

Part #	OEM#	Description	Part #	OEM#	Description
18-8815-1	OMC 582365	4" Spark Plug Wire	①③ 18-5229-9-1	Universal	22" Spark Plug Wire (pkg of 5)
18-8816-1	OMC 582365	6" Spark Plug Wire	①③ 18-5230-9-1	Universal	10" Spark Plug Wire (pkg of 5)
18-5231-1			18-8839-1	—	90 & 115 hp Outboard Wire Set
② 18-5231-1D	OMC 582365	9" Spark Plug Wire	18-8840-1	—	150 & 175 hp Outboard Wire Set
18-8818-1	OMC 582365	12" Spark Plug Wire			

OUTBOARD

PKG. OF 10



18-5224
18-5224-9①
SPARK PLUG WIRE TERMINAL
Replaces: 510364



18-5225
SPARK PLUG WIRE KIT
Includes 25 ft Roll of Hypalon Ignition Wire with a copper conductor and a large assortment of three different end fittings to fit Johnson/Evinrude motors.



18-5226
IGNITION WIRE
(100' Spool)
Hypalon
Replaces: 510883, 772584



MP39100
IGNITION SWITCH
Replaces: 386545
(5 Terminals - Pistol Shaped Key - 3 Position)



MP39760
IGNITION SWITCH
Replaces: 393301, 508180
(6 Terminals - Push to Choke - 3 Position)



MP39830
IGNITION SWITCH
Replaces: 386545
(6 Terminals - Pistol Shaped Key - 3 Position)
Pollak



18-1282
LANYARD & CLIP
Replaces: 398602
Tiller Steer Models - ALL



MP28870
SWITCH & LANYARD
Replaces: 585134



MP28880
LANYARD
Replaces: 432230
1995-older

① Priced per package

② Items ending in "D" are Display Packaged - Regular number is Non-Display

③ Uses 7mm copper core

<p>PKG. OF 10</p>  <p>18-5750 18-5750-9① UNIVERSAL SPARK PLUG BOOTS Supplied complete w/ Terminal Connector Replaces: 581027, 580339</p>	 <p>18-5752 UNIVERSAL SPARK PLUG BOOT 8mm</p>
 <p>18-5877 STATOR Replaces: 584643 For: 185-300 HP Loopers (1993 &UP)</p>	 <p>18-5878 STATOR Replaces: 584981 For: 150-175 HP (1993-02)</p>
 <p>18-1504 TIMER BASE Replaces: 584586 For: 185/200/225/250 & 3.0L Sea drives</p>	 <p>18-2585 TRIM SEAL KIT Replace: 393942 Fits: 60hp - V6 (1990) and older, V8 (1991-93)</p>
 <p>18-6277 TILT/TRIM ASSEMBLY Replaces: 435548 Heavy Duty, 2 Wire Connection, Flat Blade Shaft Fits : OMC V6(1993), Commercial V8 (1993-Up)</p>	 <p>18-6280 TILT/TRIM ASSEMBLY Replaces: 437801 Heavy Duty, OMC J Suffix 40,48,50HP(1992-Up)/w/ 2 Wire Connection and Hollow Hex Shaft</p>

JOHNSON/EVINRUDE (OMC/BRP) Electrical System



OUTBOARD



**18-6281
TILT/TRIM MOTOR**
Replaces: 438786, 439937, 5005254
Heavy Duty for OMC Outboards 75HP-250HP EFI(1998-Up)



**18-6285
TILT/TRIM ASSEMBLY**
Replaces: 433226
Heavy Duty OMC (1989-92) M Suffix 40,48,50HP w/ 2 Wire Connection and Hollow Hex Shaft



**18-6756
TILT/TRIM MOTOR**
Fits: (1982-98) 2 cylinder 2 stroke engines that have been fitted with tilt kit 173946.



**18-6759
TILT/TRIM MOTOR**
Replaces: 394176, 391264, 393988, 985237
Newer 2 wire design for most 3, 4, 6 and 8 cyl. applications 1982 to present (Motor Only)
Use **18-7510** O-Ring
Replaces: 321163



**18-6761
TILT/TRIM MOTOR**
Replaces: 387277, 582048, 582155, 584107
Older 3 wire design for most 3, 4, 6 cylinder outboards up to 1981 (Motor Only)



**18-6762
TILT/TRIM MOTOR**
Replaces: 172543
For most 85, 115 and 135 H.P. V-4 applications (Motor and Reservoir)



**18-6767-1
TILT/TRIM MOTOR**
Replaces: 172850, 173564, 173596
For: 1974 (115 & 135 HP)
For most 45 H.P. commercial models 1989-90, 2 cylinder applications (1984-88), 3 cylinder applications (1977-83) and 4 cylinder applications (1974-77)
(Motor and Reservoir)
For Repair Kit use **18-6252**



**18-6780
TILT/TRIM MOTOR**
Replaces: 438529, 438531
For: 90, 115, 200, 225 HP (1991-Up); 120, 140 HP (1991-94); 130 HP (1995-Up)



**18-6252
TILT & TRIM
MOTOR REPAIR KIT**
For use with **18-6767-1**

NEW



POWER TRIM ASSEMBLIES

PART NO.	OE NO.	APPLICATION
18-6801	5005113	115-130HP, V4 (2000-09)
18-6802	5005114	135-200HP, V6, 60° (2000-09)
18-6803	5005115/5007662	200-250HP, V6, 90° (2000-09)



**18-5501
INTERNAL WIRING HARNESS**

- Replaces: 383327
- Round Plug Style
 - Soldered connections, braided covering and high temperature burn proof wire.
 - For Prestolite and Motorola ignition systems.
 - Fits: 55HP (1969) Round plug style.
 - Amp/Pulse Pack Type: 6CB2007
 - Amp/Pulse Pack: 389549



**18-5705
POWER TRIM RELAY**

Replaces:
582472, 584416, 586224
5 Terminal • Single Pull
Double Throw • 12 Volt

Contact	Resistive	Conductive
Open	40 Amps	30 Amps
Closed	20 Amps	15 Amps

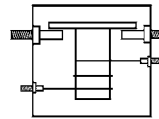

① **18-5823D**

Display Package



**18-5823
SOLENOID**

Replaces: 584580
Fits: 9.9 4-stroke(1995-01), 9.9 (1993 & Up),
15 4-stroke(1995-01), 15 (1993 & Up), 8 (1996-98),

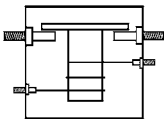

① **18-5833D**

Display Package



**18-5833
SOLENOID**

Replaces: 586774
Fits: E40 (2004-07), E50 (2004-06), E60 (2006-07), E75 (2004-07), E90 (2004-07), E115 (2007), E150 (2007), E175 (2007), E200 (2005-07), E225 (2005-07), E250 (2005-07)

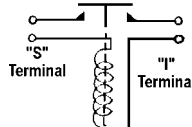

**18-5807
SOLENOID**

Replaces: 378444, Prestolite SAW4206

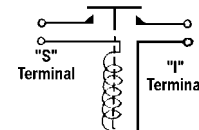

① **18-5808D**

Display Package



**18-5808
SOLENOID**



Replaces: 395419, 582708

SOLENOID APPLICATION ON NEXT PAGE

① Items ending in "D" are Display Packaged - Regular number is Non-Display

JOHNSON/EVINRUDE (OMC/BRP) Electrical System



 <p>18-5813 SOLENOID Replaces: 584128</p>	 <p>18-5814 SOLENOID Replaces: 581528, 172869</p>	 <p>BATTERY CABLES Gauge cable with soldered lug terminals on each end to accept 3/8" stud.</p> <table border="1" style="width: 100%; border-collapse: collapse;"> <thead> <tr> <th>Part No.</th> <th>Size</th> <th>Color</th> <th>Gauge</th> </tr> </thead> <tbody> <tr><td>BC88523</td><td>2'</td><td>red</td><td>4</td></tr> <tr><td>BC88533</td><td>2'</td><td>black</td><td>4</td></tr> <tr><td>BC88543</td><td>4'</td><td>red</td><td>2</td></tr> <tr><td>BC88553</td><td>4'</td><td>black</td><td>2</td></tr> <tr><td>BC88563</td><td>6'</td><td>red</td><td>2</td></tr> <tr><td>BC88573</td><td>6'</td><td>black</td><td>2</td></tr> <tr><td>BC88583</td><td>8'</td><td>red</td><td>1</td></tr> <tr><td>BC88593</td><td>8'</td><td>black</td><td>1</td></tr> </tbody> </table>	Part No.	Size	Color	Gauge	BC88523	2'	red	4	BC88533	2'	black	4	BC88543	4'	red	2	BC88553	4'	black	2	BC88563	6'	red	2	BC88573	6'	black	2	BC88583	8'	red	1	BC88593	8'	black	1
Part No.	Size	Color	Gauge																																			
BC88523	2'	red	4																																			
BC88533	2'	black	4																																			
BC88543	4'	red	2																																			
BC88553	4'	black	2																																			
BC88563	6'	red	2																																			
BC88573	6'	black	2																																			
BC88583	8'	red	1																																			
BC88593	8'	black	1																																			

OUTBOARD

Model	Year	Starter Solenoid	Trim Solenoid Relay	Model	Year	Starter Solenoid	Trim Solenoid Relay	Model	Year	Starter Solenoid	Trim Solenoid Relay		
9.9/15	1991-92	18-5813	N/A	65	③	1968-73	18-5808	N/A	110	1986-89	18-5808	18-5705	
18	1957-59	18-5807	N/A	65	③	1985-92	18-5808	18-5705	115	1969-75	18-5808	N/A	
20	①	1981-92	18-5808	N/A	70	1961	18-5807	N/A	115	1976-81	18-5808	18-5814	
25	①	1972-92	18-5808	N/A	70	1974-80	18-5808	N/A	115	1982-92	18-5808	18-5705	
28	1987-92	18-5808	N/A	70	1981	18-5808	18-5814	120	1985-92	18-5808	18-5705		
30	①	1984-92	18-5808	N/A	70	1982-92	18-5808	18-5705	125	③	1971-81	18-5808	N/A
33	1965-67	18-5807	N/A	75	1960-64	18-5807	N/A	125	③	1982-92	18-5808	18-5705	
33	1968-70	18-5808	N/A	75	④	1965	18-5807	N/A	135	1973	18-5808	N/A	
35	1957-59	18-5807	N/A	75	⑤	1965	18-5808	N/A	135	1974-75	18-5808	—	
35	1976-88	18-5808	N/A	75	1975-80	18-5808	N/A	135	1976	18-5808	18-5814		
40	1960-66	18-5807	N/A	75	1981	18-5808	18-5814	140	1977-81	18-5808	18-5814		
40	1967-92	18-5808	N/A	75	1982-88	18-5808	18-5705	140	1982-92	18-5808	18-5705		
45	②	1989-92	18-5808	N/A	80	④	1966	18-5807	N/A	150	1979-81	18-5808	18-5814
45SS	1988-90	18-5808	N/A	80	⑤	1966	18-5808	N/A	150	1982-92	18-5808	18-5705	
48	1987-92	18-5808	N/A	80	1967	18-5808	N/A	155	②	1984-92	18-5808	18-5705	
50	1958-59	18-5807	N/A	85	1968-75	18-5808	N/A	2500cc	1988	18-5808	18-5705		
50	1971-79	18-5808	N/A	85	1976-80	18-5808	18-5814	175	1977-81	18-5808	18-5814		
50	1981-83	18-5808	—	85	1991-92	18-5808	18-5705	175	1982-92	18-5808	18-5705		
50	1984-92	18-5808	N/A	88	1987-92	18-5808	18-5705	185	1984-92	18-5808	18-5705		
55	1968-80	18-5808	N/A	90	1964	18-5807	N/A	200	1976-81	18-5808	18-5814		
55	1981	18-5808	—	90	1965	18-5808	N/A	200	③	1982-92	18-5808	18-5705	
55	②	1989-92	18-5808	N/A	90	1981	18-5808	18-5814	225	1986-92	18-5808	18-5705	
60	1964-66	18-5807	N/A	90	1982-92	18-5808	18-5705	235	1978-81	18-5808	18-5814		
60	1967-80	18-5808	N/A	100	1966-72	18-5808	N/A	235	1982-85	18-5808	18-5705		
60	1981-83	18-5808	—	100	1979-80	18-5808	18-5814	250	1991-92	18-5808	18-5705		
60	1984-92	18-5808	18-5705	100	②	1984-92	18-5808	18-5705	275	1985-88	18-5808	18-5705	
SST 60	1989-90	18-5808	18-5705	1600cc	②	1988	18-5808	18-5705	3.6L/300	1985-92	18-5808	18-5705	

① Electric start only
④ w/o electric shift

② Commercial models
⑤ w/electric shift

③ Also commercial models

⑥ Items ending in "D" are Display Packaged - Regular number is Non-Display

 <p>18-5708 RECTIFIER Replaces: 582399, 583408 6-10 AMP</p>	 <p>18-5709 RECTIFIER Replaces: 581778 4-5 AMP</p>	
 <p>18-5825 REGULATOR/RECTIFIER Replaces: 395204</p>	 <p>18-5826 REGULATOR/RECTIFIER Replaces: 584890</p>	
 <p>18-5827 REGULATOR/RECTIFIER Replaces: 585001, 584476</p>	 <p>18-5828 REGULATOR/RECTIFIER Replaces: 585219, 439561</p>	 <p>18-5829 REGULATOR/RECTIFIER Replaces: 586048</p>
 <p>18-5830 REGULATOR/RECTIFIER Replaces: 586075</p>	 <p>18-5831 REGULATOR/RECTIFIER Replaces: 586271, 584641, 585995</p>	 <p>18-5832 REGULATOR/RECTIFIER Replaces: 583266, 583689, 586000, 584424</p>

OUTBOARD

REGULATOR/RECTIFIER APPLICATION ON NEXT PAGE

JOHNSON/EVINRUDE (OMC/BRP)

Electrical System





Model	Year	Part #	Model	Year	Part #
9.9,15	1974-92	18-5709	90-115 60 Degree-V4	1996-Up	18-5830
20	1989-98 ④	18-5709	100	1971, 1979-80, 1984-92 ③	18-5708
25	1977-03 (2 Cyl) ④	18-5709	115	1973-92	18-5708
25/40/50TL/ J Elec TR	1992	18-5827	120/140	1985	18-5832
25SIK/ SIL/ SIT	1994-1995	18-5827	125	1971-72	18-5708
25/35 3 Cyl.	1995-Up	18-5826	135	1974 ⑦	18-5708
28	1989-96	18-5709	135	1973, 1975-76	18-5708
30	1989-03 (2 Cyl) ④	18-5709	140	1977-88	18-5708
35	1976-93 (2 Cyl) ④	18-5709	150	1979-88	18-5708
35JET/ TL/ J Elec.	1992-1993	18-5827	150/175 60 Degree-V6	1991-1995	18-5828
35JET/ M-TE/ TTL	1993-1995	18-5827	150/175 60 Degree-V6	1996-Up	18-5829
35JET/ EL/ TL/ TTL	1996	18-5827	155	1984-88	18-5708
35JET Elec.	1997	18-5827	175	1977-83	18-5708
40	1974-76, 1988-92	18-5709	185	1984-88	18-5708
40/50TE/ EL/ TL/ TTL	1993-1996	18-5827	185/200/225	1993-1994	18-5831
40/ 50 Elec. 2 Cycle.	1993-03 (2 Cycle.)	18-5827	185/200/225/200COMM	1990-1992	18-5832
45	1989-92 COMM	18-5709	200	1976-83	18-5708
45SS	1989-90	18-5709	200/225	1986-1989	18-5832
48	1989-92	18-5709	200/225/200COMM	1994-1997	18-5831
50	1971-75	18-5708	235	1978-88	18-5708
50	1979-92	18-5709	250/300	1991-1995	18-5831
55	1976-77	18-5708	250	1997	18-5831
55	1978-81, 1980-92 ①	18-5709	275	1985-1986	18-5832
60	1970 ⑤, 1971	18-5708	275/300 (3.6L)	1987	18-5832
60	1980-88	18-5709	275/300	1988	18-5832
60	1989-91 ⑥	18-5708	300 (3.6L) — Port & Stbd.	1985-1986	18-5832
SST60	1989-90	18-5708	300	1989-1990	18-5832
60	1992-01	18-5827	1.8/2.0L V4 "S"	1987-1990	18-5832
65	1972-73, 1988-91	18-5708	2.7L V6	1986-1987	18-5832
65 Elec.	1992	18-5827	3.0L V6	1988-1990	18-5832
70	1974-91 ②	18-5827	3.0L V6	1993-1998	18-5832
70	1992-01	18-5708	3.6L V8	1987	18-5832
75	1975-88	18-5708	4.0L V8	1989-1990	18-5832
85	1970-80	18-5708	V-4 & V-6 Crossflow with 35 AMP	ALL	18-5825
88	1989-92	18-5708			
90	1981-92	18-5708			

- ① Also Commercial Models
- ② 1991 EL & TL Models only
- ③ Except 1992 Models WTLNE & WTXENE
- ④ Electric Start only
- ⑤ D Models only
- ⑥ EL & TL Models only
- ⑦ 135443, 135483 Models only

 <p>18-6434 OUTBOARD STARTER Replaces: 386430 Fits: 9.9, 15 HP (1974-92), 8 HP 4 Stroke (1996-98)</p>	 <p>18-5600 PREMIUM OUTBOARD STARTER Replaces: 395207, 387094, 585062, 586288</p> <p>18-5640 O.E. EQUIVALENT OUTBOARD STARTER Replaces: 395207, 387094, 585062, 586288</p>	 <p>18-5612 OUTBOARD STARTER Replaces: 432925, 586287, 586286</p>
---	--	---

 <p>18-5617 OUTBOARD STARTER Replaces: 586274</p>	 <p>18-5619 OUTBOARD STARTER Replaces: 584799, 396235, 391511, 397023, 586731</p>	 <p>18-5624 OUTBOARD STARTER Replaces: 583482, 585056</p>
--	--	---

OUTBOARD

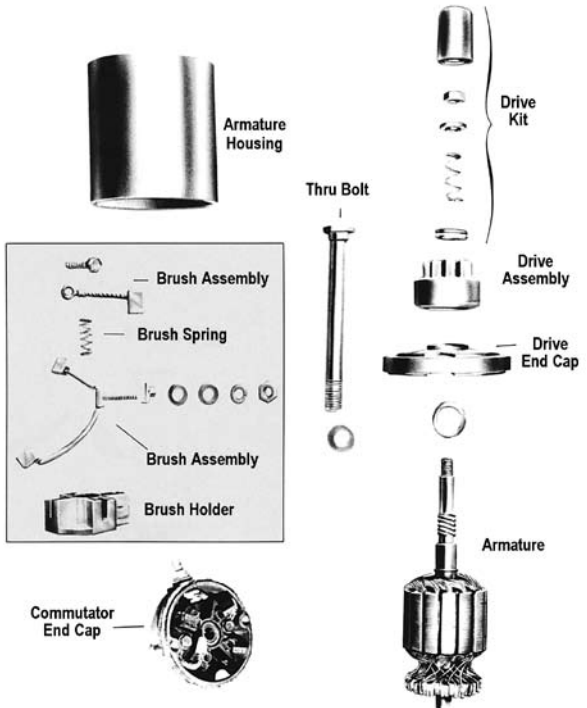
 <p>18-5627 OUTBOARD STARTER Replaces: 583473, 585059, 585459</p>	<p>EXPLODED VIEW OF STARTER</p>	
 <p>18-5628 OUTBOARD STARTER Replaces: 393570, 585060</p>		

ALL STARTERS ARE COUNTER CLOCKWISE ROTATION
STARTER APPLICATION BEGINS ON PAGE 175

JOHNSON/EVINRUDE (OMC/BRP)

Electrical System



OUTBOARD

 <p>18-5629 PREMIUM OUTBOARD STARTER Replaces: 392133, 585061, 386591</p> <p>18-5645 O.E. EQUIVALENT</p>	 <p>18-5630 PREMIUM OUTBOARD STARTER Replaces: 387684, 585063, 389275, 384163</p> <p>18-5646 O.E. EQUIVALENT</p>	 <p>18-5631 OUTBOARD STARTER Replaces: 584818, 586277</p>	
 <p>18-5632 OUTBOARD STARTER Replaces: 584980, 586284</p>	 <p>18-5634 PREMIUM OUTBOARD STARTER Replaces: 585057, 585051, 385529, 389954</p> <p>18-5647 O.E. EQUIVALENT</p>	 <p>18-5635 PREMIUM OUTBOARD STARTER Replaces: 585058, 586281, 386657, 391735, 585050, 384777</p> <p>18-5648 O.E. EQUIVALENT</p>	
 <p>18-6250 OUTBOARD STARTER REPAIR KIT Prestolite 2 Brush</p>	 <p>18-6251 OUTBOARD STARTER REPAIR KIT Prestolite 4 Brush</p>	 <p>18-5655 DRIVE ASSEMBLY Replaces: 321648 See next page for additional application</p>	 <p>18-5671 DRIVE ASSEMBLY Replaces: 384781 See next page for additional application</p>
 <p>18-5674 DRIVE ASSEMBLY Replaces: 387683 See next page for additional application</p>	 <p>18-5678 DRIVE ASSEMBLY Replaces: 585269 See next page for additional application</p>	 <p>18-5679 DRIVE ASSEMBLY Replaces: 585267 See next page for additional application</p>	 <p>18-5697 DRIVE BRUSH KIT Replaces: 385952 See next page for additional application</p>

STARTER APPLICATION BEGINS ON NEXT PAGE

H.P.	Years	Starter #	OE Part #	O.E. #	Drive ^② Assembly	O.E. #	Tooth Count	Drive ^⑤ Brush Kit	O.E. #
9.9/ 15	1974-92	—	386430	395264	—	319977	10	NA	NA
9.9/ 15	1993 & Up	18-5617	586274	395264	—	319977	10	NA	NA
9.9/ 15	1997 & Up 4 stroke	—	584613	NSS	18-5679 ①	585267	10	18-5697	385952
20 ⑦	1985-88	18-5629	586278	393354	18-5655	321648	11	18-5697	385952
20 thru 30 ⑦	1993-98	18-5629	586278	393354	18-5655	321648	11	18-5697	385952
25 thru 35 ⑦	1977-88	18-5629	586278	NSS	18-5655	321648	11	18-5697	385952
20 thru 30 ⑤	1989-92	18-5627	585059	393354	18-5671 ①	384781	9	18-5697	385952
25 thru 35	1997-99 3 cylinders	18-5631	586277	586100	NSS ①	NSS	10	18-5697	385952
40-50	1984-88	18-5630	586280	NSS	18-5671 ①	384781	9	18-5697	385952
50	1972	18-5630	586280	NSS	18-5671 ①	585269	9	18-5697	385952
40-50 ①	1989-99	18-5624	586279	NSS	18-5678 ①	585269	9	18-5697	385952
55	1978	18-5630	586280	NSS	18-5678 ①	585269	9	18-5697	385952
60	1985 2 cylinders	18-5630	586280	NSS	18-5678 ①	585269	9	18-5697	385952
50	1985-99 3 cylinders	18-5635	586281	NSS	18-5678 ①	585269	9	18-5697	385952
55	1969	18-5635	586281	NSS	18-5678 ①	585269	9	18-5697	385952
60	1971	18-5635	586281	NSS	18-5671 *	384781	9	18-5697	385952
60	1986-01 3 cylinders	18-5635	586281	NSS	18-5678 ①	585269	9	18-5697	385952
65	1985-01 3 cylinders	18-5635	586281	NSS	18-5678 ①	585269	9	18-5697	385952
70, 75	1980-01	18-5635	586281	NSS	18-5678 ①	585269	9	18-5697	385952
85 thru 115	1973-99 crossflows	18-5634	586283	NSS	18-5679 ①	586100	10	18-5697	385952
90, 115	1995-99 looper	18-5632	586284	NA	NA	NA	NA	18-5697	385952
120 thru 140	1985-94	18-5628	586285	NSS	18-5679 ①	586100	10	18-5697	385952
130	1995-99	18-5628	586285	NSS	18-5679 ①	586100	10	18-5697	385952
V-6 Crossflow	1976-92	18-5600	586288	393285	18-5674	387683	8	18-5697	385952
150, 175 60°	1991-99 loopers	18-5612	586286	NA	NA	NA	NA	18-5697	385952
150 thru 175 V-6	1997-03	18-5612	586287	NSS	NSS	NA	NA	NA	433850
200 thru 300	1986-Up std. rotation	18-5619	586411	397375	NA	NA	10	18-5697	385952

Note: Some starters will replace Prestolite versions however replacement parts are for Bosch versions only.
* Starter drive retained with nut

NSS Not sold separately

① Drive kit includes drive assembly with clip style retainer

② Drive kits, drive assemblies, and brush sets offered are for "Bosch Style" starters only.

⑤ With 9 tooth pinion

⑦ For Bosch models

4 STROKE FUEL SYSTEM KITS



18-7761
CARBURETOR REBUILD KIT

Fits: Johnson/Evinrude Four-Stroke 4-6 hp. (2007)

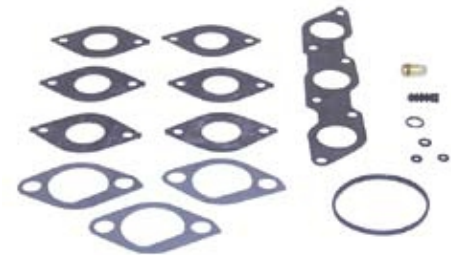

18-7773
CARBURETOR REBUILD KIT

Replaces: 5032424
25, 30 HP (2000-01) (2004 & Up)

2 STROKE FUEL SYSTEM KITS



18-7010
CARB KIT

Replaces: 382050, 382051, 382054



18-7024
CARB KIT

Replaces: 382053, 382052, 385356



18-7026
CARB KIT





Replaces: 382057

JOHNSON/EVINRUDE (OMC/BRP)

Fuel System



OUTBOARD

 <p>18-7042 CARB KIT (without float) Replaces: 392061, 398729, 396701</p>	 <p>18-7222 CARB KIT (with float) Replaces: 392061, 398729, 396701</p>	 <p>18-7043 CARB KIT Replaces: 382045, 382046, 382047, 382049, 383052, 383067, 398532, 439071</p>									
 <p>18-7046 CARB KIT Replaces: 390055, 392550, 398526, 435443, 434888, 439076</p>	 <p>18-7219 CARB KIT Replaces: 439073, 431897</p>	 <p>18-7220 CARB KIT Replaces: 435676, 435677, 435678, 435752</p>									
 <p>18-7221 CARB KIT Replaces: 435677</p>	 <p>18-7223 CARB KIT Replaces: 398452, 391305, 398453, 439072, 391937</p>	 <p>18-7247 CARB KIT Replaces: 438996, 435442, 436852 For: V4 & V6 (90°) 1988-2001</p>	 <p>18-7248 CARB KIT Replaces: 437327, 439079, 439078</p>								
 <p>18-7217 CARB KIT For: 2, 2.3, 3.3 H.P. (1995-99) 2, 3 H.P. (2000-02), 3.5 H.P. (2002)</p>	 <p>18-0871 SERVICE VALVE WITH O-RING Replaces: 175158 Fits: All Johnson/Evinrude with primer valve (except 1993 9.9 & 15hp.)</p>	 <p>18-7044 SERVICE VALVE KIT Fits: All Johnson/Evinrude with primer valve (except 1993 9.9 & 15 H.P.)</p>	 <p>18-0993 COVER & GASKET ASSEMBLY Replaces: 437228 Fits: All Johnson/Evinrude with primer valve (except 1993 9.9 & 15hp.)</p>								
 <p>NEEDLE & SEAT</p> <table border="1"> <thead> <tr> <th>Part #</th> <th>Replaces:</th> </tr> </thead> <tbody> <tr> <td>18-7093</td> <td>396521, 678882, 378895</td> </tr> <tr> <td>18-7094</td> <td>379313, 396522</td> </tr> <tr> <td>18-7038</td> <td>396520, 379312, 387262</td> </tr> </tbody> </table>	Part #	Replaces:	18-7093	396521, 678882, 378895	18-7094	379313, 396522	18-7038	396520, 379312, 387262	<p>PKG. OF 10</p>  <p>18-7106 18-7106-9[Ⓢ] NEEDLE PACKING Replaces: 307583</p>	 <p>18-7210 FLOAT Replaces: 382363</p>	<p>PKG. OF 5</p>  <p>18-7296 18-7296-9[Ⓢ] ADJUSTING NEEDLE RETAINER Replaces: 315232</p>
Part #	Replaces:										
18-7093	396521, 678882, 378895										
18-7094	379313, 396522										
18-7038	396520, 379312, 387262										

Ⓢ Priced per Package

APPLICATION BEGINS ON NEXT PAGE



JOHNSON/EVINRUDE (OMC/BRP) Fuel System

HP	Year		Carb. Kit w/o Float	Carb. Kit w/ Float	Needle & Seat	Carb. Float
1.5	1970-90		18-7043	—	18-7094	—
2	1970-90		18-7043	—	18-7094	—
3	1952-67		18-7043	—	18-7038	—
3	1968		18-7043	—	18-7094	—
4	1983-89		18-7223	—	18-7094	—
4	1991-93		18-7223	—	18-7094	—
4.5	1982-84, 1987		18-7223	—	18-7094	—
5	1965-67		18-7043	—	18-7094	—
5	1968		18-7024	—	18-7093	—
5	1984-85		18-7223	—	18-7094	—
5.5	1954-67		18-7043	—	18-7094	—
6	1954-79		18-7043	—	18-7094	—
6	1968		18-7024	—	18-7093	—
6	1984-85		18-7223	—	18-7094	—
6.8	1986-96		18-7219	—	—	—
7.5	1955-58		18-7043	—	18-7094	—
7.5	1982-83		18-7223	—	18-7094	—
8	1984-85		18-7223	—	18-7094	—
9.9	1974-88		18-7223	—	18-7094	—
9.9/15	1989-96		18-7219	—	—	—
10	1954-63		18-7043	—	18-7094	—
14	1968	③	18-7223	—	18-7094	—
15	1955-56		18-7043	—	18-7094	—
15	1974-88		18-7223	—	18-7094	—
18	1957-68		18-7043	—	18-7094	—
18	1969-73		18-7042	18-7222	18-7093	18-7210
20	1957-68		18-7043	—	18-7094	—
20	1969-90		18-7042	18-7222	18-7093	18-7210
20	1991-96		18-7219	—	18-7094	—
25	1954-55		18-7024	—	18-7093	—
SAIL DR	1978-Up		18-7042	18-7222	18-7093	18-7210
25	1969-95	⑤	18-7042	18-7222	18-7093	18-7210
28	1962-64		18-7010	—	18-7093	—
28	1976-95		18-7042	18-7222	18-7093	18-7210
30	1956		18-7024	—	18-7093	—
30	1976-Up		18-7042	18-7222	18-7093	18-7210
33	1965-70		18-7010	—	18-7093	—
35	1957-59		18-7024	—	18-7093	—
35	1959		18-7010	—	18-7093	—
35	1976-95	⑤	18-7042	18-7222	18-7093	18-7210
40	1960-63, 1971		18-7010	—	18-7093	—
40	1965-70, 1972-78		18-7024	—	18-7093	—
40	1971-90, 1979-92	①	18-7042	18-7222	18-7093	18-7210
45	1971-97	②	18-7042	18-7222	18-7093	18-7210
48	1992-97		18-7042	18-7222	18-7093	18-7210
50	1958-59		18-7026	—	18-7093	—
50	1971-97		18-7042	18-7222	18-7093	18-7210
55	1968-69, 1971-97	②	18-7042	18-7222	18-7093	18-7210
60	1964-67		18-7026	—	18-7093	—
60	1970-97		18-7042	18-7222	18-7093	18-7210
65	1972-97		18-7042	18-7222	18-7093	18-7210
70	1972-97 (3 cyl)		18-7042	18-7222	18-7093	18-7210
75	1960-63		18-7026	—	18-7093	—
75	1975-88		18-7042	18-7222	18-7093	18-7210
80	1966-67		18-7026	—	18-7093	—
85	1968		18-7026	—	18-7093	—
85	1971-79		18-7046	—	18-7093	—
85	1969-70, 1991-93		18-7046	—	18-7038	—
V-4	1969-79		18-7046	—	18-7038	—
V-4	1983-84		18-7046	—	18-7038	—
88,90	1985-95		18-7046	—	18-7038	—
90	1981-82, 1983	③	18-7046	—	18-7038	—
90	1995-02		18-7247	—	—	—
100	1971, 1980		18-7046	—	18-7038	—
100	1972, 1979		18-7046	—	18-7093	—
100	1998-01		18-7247	—	—	—
105	1999-01		18-7247	—	—	—
115	1969, 1980-95		18-7046	—	18-7038	—
115	1995-02		18-7046	—	18-7093	—
115	1995-02		18-7247	—	—	—
V-6	1976-90	④	18-7046	—	18-7038	—
115	1983		18-7046	—	18-7038	—
120	1985-90		18-7220	—	18-7094	—
120	1985-90, 1993		18-7220	—	18-7094	—
125	1971-72		18-7046	—	18-7093	—
125	1993		18-7220	—	18-7094	—

① Commercial ② Also Commercial ③ Early Production ④ Cross Flow ⑤ Except 1995-Up 3 Cylinder Models

APPLICATION CONTINUED ON NEXT PAGE

OUTBOARD

JOHNSON/EVINRUDE (OMC/BRP)

Fuel System



HP	Year	Carb. Kit w/o Float	Carb. Kit w/ Float	Needle & Seat	Carb. Float
125C	1989-95	18-7220	—	18-7094	—
135	1973-76	18-7046	—	18-7093	—
140	1977, 1980-83	18-7046	—	18-7038	—
140	1978-79	18-7046	—	18-7093	—
140	1985-90	18-7220	—	18-7094	—
140	1993	18-7220	—	18-7094	—
150	1979-90	18-7046	—	18-7038	—
150	1992-96, 1998-02	18-7247	—	—	—
155	1984-93	18-7046	—	18-7038	—
175	1977-91	18-7046	—	18-7038	—
175	1992-96, 1998-02	18-7247	—	—	—
185	1984	18-7046	—	18-7038	—
185	1989-93	18-7221	—	18-7094	—
200	1976-83	18-7046	—	18-7038	—
200	1986-90	18-7220	—	18-7094	—
200	1992-93	18-7221	—	18-7094	—
225	1986-90, 1992-93	18-7221	—	18-7094	—
235	1978-84	18-7046	—	18-7038	—
250	1991-93	18-7221	—	18-7094	—
275\3.6L	1985-88	18-7221	—	18-7094	—
300	1988, 1991-93	18-7221	—	18-7094	—

① Commercial ② Also Commercial ③ Early Production ④ Cross Flow ⑤ Except 1995-Up 3 Cylinder Models



**18-7350
FUEL PUMP**

Replaces: 397839, 391638, 395091, 397274
For: 6/8/9/15 HP 1992 and older



**18-7351
FUEL PUMP**

Replaces: 438562
For: 9.9/15 HP 1993-2006
Uses kit 18-7800



**18-7352
FUEL PUMP**

Replaces: 438556, 388268, 385781, 394543, 382354, 395713, 398338, 432451, 398387, 433387
For: 25-55 HP 1976-89 (non-VRO)



**18-7353
FUEL PUMP**

Replaces: 438555, 433386
For: 20-30 HP 1990-2000



**18-7800
FUEL PUMP KIT**
Replaces: 438616, 433519





**18-7801
FUEL PUMP KIT**
Replaces: 379777



Display Package



**18-7820
FUEL PUMP KIT**
Replaces: 393103

FUEL PUMP KIT APPLICATION ON NEXT PAGE

 <p>18-7821 FUEL PUMP KIT Replaces: 398514, 395867</p>	 <p>18-7822 FUEL PUMP KIT Replaces: 432962</p>
--	--

 <p>18-7823 FUEL PUMP KIT Replaces: 393088</p>	<p>PKG. OF 2</p>  <p>18-7796 18-7796-9④ CHECK VALVE Replaces: 335334 (Enlarged to show detail)</p>	 <p>18-3501 DIAPHRAGM & CUP ASSEMBLY Replaces: 435957 For: 8 (1996-97), 10 (1996-97), 15 (1996-97), 40 (1995-97), 50 (1995-97), 55 (1995-97), 60 (1993-96), 65 (1993-96), 70 (1993-96), 120 (1993-94), 125 (1993-95), 130 (1995-96), 140 (1993-94), 250 (1994-95), 300 (1994-95),</p>
--	--	---

<p>NEW</p>  <p>18-3497 DIAPHRAGM KIT Replaces: 5033372 4-5 HP (2003-06), 6 HP (2005-06) 4-Stroke</p>	<p>NEW</p>  <p>18-3498 DIAPHRAGM KIT Replaces: 5036216 9.9-15 HP (2005-07) 4-Stroke</p>	<p>NEW</p>  <p>18-3499 DIAPHRAGM KIT Replaces: 5030699 9.9, 15 HP (2002-04), 25HP (2004-06), 30HP (2004-07), 40-70 HP (2002-06) 4-Stroke</p>
--	--	--

OUTBOARD

FUEL PUMP REPAIR KIT APPLICATION

Model	Year	Part #	Model	Year	Part #	Model	Year	Part #
2.5	1987-88	18-7823	30/35	1976-86	18-7820	65	1990	18-7821 ①
4	1981-Up	18-7823	35	1958-59	18-7801	65 Comm	1984	18-7820
4.0 Deluxe	1992-93	18-7823	40	1960-64	18-7801	65 Comm	1988-89	18-7821
4.5	1982-87	18-7823	40	1987	18-7821	70/75	1982-84	18-7820
5	1985-93	18-7823	40	1990-Up	18-7800	70	1990	18-7821
6	1986-93	18-7823	40 ②	1970-78	18-7820	75	1960-65	18-7801
6.5	1989-90	18-7823	40/50	1988-89	18-7822	80	1966-67	18-7801
7.5	1982-83	18-7823	45	1958-59	18-7801	85	1978-83	18-7820
8	1984-93	18-7823	45/48/50② ③	1989	18-7822	88	1987	18-7821
9.9/15	1981	18-7820	45/48/50② ③	1990-up	18-7800	88/90/110	1988-89	18-7821
9.9/15	1982-Up	18-7823	45/55	1985-86	18-7821	88/90/100/115	1990	18-7821 ①
9.9 Electric & 15	1987-89	18-7821	45/55	1987	18-7821	88/100/125	1990-Up	18-7800
9.9 Electric & 15	1990-Up	18-7800	45/55 Comm	1989-90	18-7821 ①	90	1964-65	18-7801
10/14	1989-90	18-7823	48	1987	18-7821	90/115	1978-83	18-7820
14	1988	18-7823	48	1988	18-7822	90/115/140	1982	18-7820
20/25	1977-86	18-7820	48/50	1990	18-7822 ①	100	1966	18-7801
20 Thru 30	1990-Up	18-7800	50	1958-59	18-7801	100 Comm	1989-90	18-7821
20/25/30	1987	18-7821	50	1987	18-7821	125 Comm	1989-90	18-7821
20/25/30	1988-89	18-7822	50/60	1982-84	18-7820	V4 140	1978-83	18-7820
20/25/30 Rope	1990	18-7822 ①	55	1983	18-7820	150/175/200	1982	18-7820
20/30/35 Remote	1990	18-7822 ①	55 Comm	1984	18-7820	V6 150/175	1983	18-7820
20/35 Rope	1989	18-7822	55 Thru 75	1970-78	18-7820	155 Comm	1989-90	18-7821
25 Comm	1982	18-7820	60	1964-67	18-7801	V6 235	1983	18-7820
25 Comm	1988-90	18-7822	60	1988	18-7821	2.6	1984	18-7821
28	1962-63	18-7801	65	1985-87	18-7820	3.0	1991-93	18-7823
28	1987	18-7821						

① Early production pump

② Two stroke

③ Not VRO (Variable Ratio Oiling)

④ Priced per Package

- UNIVERSAL DESIGN -
DIRECT REPLACEMENT FOR MERCURY AND YAMAHA
FUEL WATER SEPARATOR BRACKETS



Bracket Type	Part #	Bracket Type	Part #
1/4" Stainless Steel	18-7777	1/4" Aluminum	18-7853-1
3/8" Stainless Steel	18-7776	3/8" Aluminum	18-7775

FUEL WATER SEPARATOR KITS



21 MICRON FILTER KITS - FOR CARBURETED ENGINES

Kit Type	Part #	Micron Rating	Contents
1/4" Aluminum (Short Filter)	18-7848-1	21	1 - 18-7844 filter & 1 18-7853-1 bracket 2 - 18-4256 1/4" pipe plugs
1/4" Aluminum Bonus Pack Contains spare filter	18-7848-2	21	2 - 18-7844 filter & 1 18-7853-1 bracket 2 - 18-4256 1/4" pipe plugs
1/4" Aluminum (Tall Filter)	18-7852-1	21	1 - 18-7845 filter & 1 18-7853-1 bracket 2 - 18-4256 1/4" pipe plugs
1/4" Aluminum Bonus Pack Contains spare filter	18-7852-2	21	2 - 18-7845 filter & 1 18-7853-1 bracket 2 - 18-4256 1/4" pipe plugs
3/8" Aluminum (Tall Filter)	18-7775-1	21	1 - 18-7845 filter & 1 18-7775 bracket 2 - 18-4264 3/8" pipe plugs
1/4" Stainless Steel (Tall Filter)	18-7777-1	21	1 - 18-7845 filter & 1 18-7777 bracket 2 - 18-4256 1/4" pipe plugs
3/8" Stainless Steel (Tall Filter)	18-7776-1	21	1 - 18-7845 filter & 1 18-7776 bracket 2 - 18-4264 3/8" pipe plugs



10 MICRON FILTER KITS FOR FUEL INJECTED ENGINES

Kit Type	Part #	Micron Rating	Contents
1/4" Aluminum (Short Filter)	18-7983-1	10	1 - 18-7944 filter & 1 18-7853-1 bracket 2 - 18-4256 1/4" pipe plugs

10 MICRON FILTER KITS FOR FUEL INJECTED ENGINES (Cont.)

Kit Type	Part #	Micron Rating	Contents
1/4" Aluminum Bonus Pack Contains spare filter	18-7983-2	10	2 - 18-7944 filter & 1 18-7853-1 bracket 2 - 18-4256 1/4" pipe plugs
1/4" Aluminum (Tall Filter)	18-7982-1	10	1 - 18-7945 filter & 1 18-7853-1 bracket 2 - 18-4256 1/4" pipe plugs
1/4" Aluminum Bonus Pack Contains spare filter	18-7982-2	10	2 - 18-7945 filter & 1 18-7853-1 bracket 2 - 18-4256 1/4" pipe plugs
1/4" Aluminum (High Capacity Filter)	18-7966-1	10	1 - 18-7866 filter & 1 18-7853-1 bracket 2 - 18-4256 1/4" pipe plugs
3/8" Aluminum (Tall Filter)	18-7986-1	10	1 - 18-7945 filter & 1 18-7775 bracket 2 - 18-4264 3/8" pipe plugs
1/4" Stainless Steel (Tall Filter)	18-7984-1	10	1 - 18-7945 filter & 1 18-7777 bracket 2 - 18-4256 1/4" pipe plugs
3/8" Stainless Steel (Tall Filter)	18-7985-1	10	1 - 18-7945 filter & 1 18-7776 bracket 2 - 18-4264 3/8" pipe plugs



10 MICRON FILTER KITS WITH DRAIN BOWLS

Sierra AquaVue™ and metal bowl separator filters allow water to be drained from the filter to extend service life. Use the AquaVue™ bowl for outboard, above deck installations. USCG regulations require the use of the flame resistant metal bowl below deck.

Kit Type	Part #	Micron Rating	Contents
1/4" Aluminum w/ AquaVue™ bowl	18-7932	10	1 - 18-7919 filter & 1 18-7853-1 bracket 1 - 18-7922 AquaVue™ bowl 2 - 18-4256 1/4" pipe plugs
1/4" Aluminum w/ metal drain bowl	18-7951	10	1 - 18-7919 filter & 1 18-7853-1 bracket 1 - 18-7924 metal bowl 2 - 18-4256 1/4" pipe plugs
1/4" Stainless Steel w/ AquaVue™ bowl	18-7937	10	1 - 18-7919 filter & 1 18-7777 bracket 1 - 18-7922 AquaVue™ bowl 2 - 18-4256 1/4" pipe plugs
1/4" Stainless Steel w/ metal drain bowl	18-7938	10	1 - 18-7919 filter & 1 18-7777 bracket 1 - 18-7924 metal bowl 2 - 18-4256 1/4" pipe plugs

COMPACT BRACKET AND SEPARATOR KIT - FOR SMALL OUTBOARDS AND FRESH WATER APPLICATIONS

18-7774
COMPACT ALUMINUM BRACKET



18-7965-1
10 MICRON COMPACT
SEPARATOR KIT
Contains:
1 - 18-7774 bracket
1 - 18-7865 filter



REPLACEMENT FILTERS



UNIVERSAL DESIGN

10 MICRON REPLACEMENT FILTERS			21 MICRON REPLACEMENT FILTERS		
Part #	Description	Replaces	Part #	Description	Replaces
18-7944	Short - 3.875"		18-7844	Short - 3.875"	
18-7945	Long - 4.35"		18-7845	Long - 4.35"	
18-7866	High Capacity - 6"				
18-7865	Compact 10 Micron				

REPLACEMENT FILTERS FOR OMC					
10 MICRON REPLACEMENT FILTERS			21 MICRON REPLACEMENT FILTERS		
Part #	Description	Replaces	Part #	Description	Replaces
18-7946	OMC thread	OMC 502905	18-7846	OMC thread	OMC 502905
18-7989	Cobra EFI	OMC 502906	18-7789	Cobra EFI	OMC 502906

JOHNSON/EVINRUDE (OMC/BRP) Fuel System



10 Micron replacement filters and kits with drain bowls

REPLACEMENT ELEMENTS			ELEMENT & BOWL KITS	
Part #	Description	Replaces	Part #	Description
18-7919	Spin on replacement	Racor S3213	18-7928	Filter & AquaVue™ Bowl Contains: 18-7919 filter, 18-7922 bowl
18-7920	Spin on replacement	OMC 771839	18-7929	Filter & Metal Bowl Contains: 18-7919 filter, 18-7924 bowl
	OMC style	Racor S3214		
REPLACEMENT BOWLS			18-7941	Filter & AquaVue™ Bowl Contains: 18-7920 filter, 18-7922 bowl
Part #	Description		18-7943	Filter & Metal Bowl Contains: 18-7920 filter, 18-7924 bowl
18-7922	AquaVue™ Collection Bowl			
18-7924	Metal Collection Bowl			



**18-7953
FUEL FILTER**
Replaces: 5035974
Fits: 25HP (2006-07) / 90,115,140 4 stroke (2005-06)



**18-7716
FUEL FILTER**
Replaces: 5032323
Fits: Johnson 25 4-Stroke (2004-05), 30 4-Stroke (2004-07), 40/60/70 4-Stroke (2002-06), 90/115/140 4-Stroke (2003-04,2006), Evinrude 25/30/40/50/70 4-Stroke (2000-01)



**18-7719
FUEL FILTER**
Replaces: 5032238
Fits: Johnson 4/5 (2003-07), 6 4-Stroke (2005-07), 10/15 4-Stroke (2002-07), 40/50/60/70 4-Stroke (2002-06), Evinrude 40/50 4-Stroke (2000-01)



**18-7722
FUEL FILTER**
Replaces: 5005266
For: E-Tec 40, 50, 60, 75, 90,115, 150, 175 & 200DPL



**18-7826
FUEL FILTER**
Replaces: 305185



Inline Fuel Filters

Part #	Application:
18-7828-1	1/4" Small Capacity (For 1/4" Fuel Line)
18-7829	1/4" Large Capacity (For 1/4" Fuel Line)
18-7830	5/16" Replaces: OMC 398327
18-7831	3/8" Replaces: OMC 398319

8' LENGTH COMPLETE FUEL LINE ASSEMBLIES

3/8" FUEL LINE ASSEMBLY



18-8009EP SILVERADO 3000 Premium

OE# 398549



**18-8063
TANK
CONNECTOR**
(SOLD SEPARATELY)



**18-8092
FUEL
CONNECTOR**

**18-8005
PRIMER
BULB**

**18-8092
FUEL
CONNECTOR**



FUEL LINE ASSEMBLY COMPONENTS
Fits: 2 HP (1 cyl.) - 75 HP (3 cyl.) (1976-02)



* Tanks and Engines for picture purpose only.

8' LENGTH COMPLETE FUEL LINE ASSEMBLIES

3/8"
FUEL LINE ASSEMBLY

NEW 18-8014EP *SILVERADO 3000 Premium*

OE# 174509



*



18-8074
HOSE
BARB
(SOLD SEPARATELY)



18-8005
PRIMER
BULB

18-8092
FUEL
CONNECTOR



*

FUEL LINE ASSEMBLY COMPONENTS
Fits: All V6 & V8 (1976-02)

 <p>18-8004 18-8004-10① PRIMER BULB 5/16"</p> <p>Replaces: 174511, 775638 Large capacity bulb</p> <p>Display Package</p>	 <p>18-8005 18-8005-10① PRIMER BULB 3/8"</p> <p>Replaces: 174512 Large capacity bulb</p> <p>Display Package</p>	<p>HOSE BARB APPLICATION</p> <table border="1"> <thead> <tr> <th>Part #</th> <th>OMC O.E. #</th> <th>Barb</th> <th>NPT</th> <th>Conn. Type</th> </tr> </thead> <tbody> <tr> <td>18-8055</td> <td>173311</td> <td>5/16"</td> <td>1/4"</td> <td>Male</td> </tr> <tr> <td>18-8074</td> <td>173312</td> <td>3/8"</td> <td>1/4"</td> <td>Male</td> </tr> </tbody> </table>		Part #	OMC O.E. #	Barb	NPT	Conn. Type	18-8055	173311	5/16"	1/4"	Male	18-8074	173312	3/8"	1/4"	Male	 <p>18-8056 18-8056-10① FUEL CONNECTOR 5/16"</p> <p>Replaces: 174508, 775640 Mates with 18-8063</p> <p>Display Package</p>
Part #	OMC O.E. #	Barb	NPT	Conn. Type															
18-8055	173311	5/16"	1/4"	Male															
18-8074	173312	3/8"	1/4"	Male															
 <p>18-8063 18-8063-10① TANK CONNECTOR</p> <p>Replaces: 502867, 772681 (1/4" NPT) Mates with 18-8056 & 18-8092</p> <p>Display Package</p>	 <p>18-8072 FUEL ELBOW 3/8" Barb w/ 3/8" NPT Thread 90°</p> <p>Replaces: 174177</p> <p>Display Package</p>	 <p>18-8092 FUEL CONNECTOR 3/8"</p> <p>Replaces: 176445, 775641 Mates with 18-8063</p> <p>Display Package</p>	 <p>18-3290 INDICATOR ELBOW</p> <p>Replaces: 321886 Pipe threaded to hose</p> <p>Display Package</p>																
<p>SAE J1527 USCG Type B1-15 SILVERADO 3000</p>  <p>16-331-0566 5/16" I.D. Replaces: 333341 Available in 1/4", 5/16", 3/8", 5/8" ID. Also available in 10' - 250' lengths.</p> <p>16-331-0386 3/8" I.D. Replaces: 125115</p>		<p>SAE J1527 USCG Type B1-15 SILVERADO 3000</p>  <p>16-331-0560 5/16" I.D.</p> <p>16-331-0380 3/8" I.D. Available in 5/16" and 3/8" ID. Also available in 50' reels.</p>																	

OUTBOARD

* Tanks and Engines for picture purpose only.

① Discount shop pack of 10 - Priced per package

JOHNSON/EVINRUDE (OMC/BRP) Fuel/Cooling Systems



BLEEDER HOSE
18-8048 **18-8050**
.090 I.D. x .220 O.D. .0625 I.D. x .190 O.D.



18-8051
FUEL LINE HOSE
Replaces: 322656
for OMC Pressurized Systems



18-8052
FUEL LINE HOSE
3/16" I.D.
Non-Pressurized Systems
Replaces: 122838



18-9125
OETIKER CLAMP KIT
Replaces: 787133

Part #	Johnson Evinrude #	Oetiker #	Description	
18-9141	787145	14100082	Oetiker Jaw Pincers	
Nominal OD				
Part #	Johnson Evinrude #	Oetiker #	Inches	mm
18-9126-9	346930	16700004	3/8"	9.5
18-9127-9	348838	16700006	13/32"	10.5
18-9128-9	349516	16700007	7/16"	11.3
18-9129-9	347107	16700010	1/2"	13.3
18-9130-9	347108	16700011	17/32"	13.8
18-9131-9	346931	16700012	35/64"	14
18-9132-9	346785	16700013	9/16"	14.5
18-9133-9	346786	16700016	5/8"	15.7
18-9134-9	348839	16700017	11/16"	17
18-9135-9	346151	16700024	13/16"	21
18-9136-9	346152	16700031	1"	25.6
18-9137-9	346153	16700037	13/16"	30.1
18-9138-9	349759	16700040	1 1/4"	31.6
18-9139-9	349729	16700053	1 5/8"	41
18-9140-9	346150	16700020	47/64"	18.5

All clamps are standard package of 10. Each package of 10 is available individually.

PKG. OF 10



Part #	Clamp O.E. #	Clamp Range	Size
① 18-8020	322652	.538 - .608	8
① 18-8021	911616	.597 - .665	10
① 18-8034	329654	.670 - .780	12
① 18-8200	322653	.360 - .406	2
① 18-8201	124249	.410 - .468	4
① 18-8202	322654	.475 - .536	6
① 18-8203	329653	.750 - .875	14
① 18-8204	324825	.875 - .975	19



SNAPPER CLAMPS



56507
LOCTITE® PST 6ML
PIPE SEALANT
Replaces: 910048
(with Teflon®)



18-3001
IMPELLER
Replaces: 277181, 434424



18-3002
IMPELLER
Replaces: 375638, 775518



18-3003
IMPELLER
Replaces: 377178, 775519



18-3005
IMPELLER
Replaces: 377992

① This product is priced per piece. To order price per package, please add -9 to the part number.

IMPELLER APPLICATION BEGINS ON PAGE 193

OUTBOARD

 <p>18-3006 IMPELLER Replaces: 378891, 775521</p>	 <p>18-3015 IMPELLER Replaces: 433935 For: 2.5, 3, 4 Ultra, Excel With Key</p>	 <p>18-3043 IMPELLER Replaces: 389642</p>	 <p>18-3044 IMPELLER Replaces: 385072</p>
 <p>18-3050 18-3050-10^① IMPELLER Replaces: 386084</p>	 <p>18-3051 IMPELLER Replaces: 395289</p>	 <p>18-3053 IMPELLER Replaces: 396725 Wedge Key</p>	 <p>18-3055 IMPELLER Replaces: 389589</p>
 <p>18-3059 18-3059-10^① IMPELLER Replaces: 395864, 397131, 435821, 435748, 5001593 Includes 18-3299 Impeller Key</p>	 <p>18-3082 IMPELLER Replaces: 382547 Slotted Key</p>	 <p>18-3083 IMPELLER Replaces: 377230, 777213</p>	 <p>18-3090 IMPELLER Replaces: 387361</p>
 <p>18-3091 IMPELLER Replaces: 389576</p>	 <p>18-3099 IMPELLER Replaces: 5033112 For: 4 Stroke 9.9 and 15 HP (2002-up)</p>	 <p>18-3104 IMPELLER Replaces: 432941, 437059</p>	 <p>18-3366 IMPELLER Replaces: 390286</p>

APPLICATION BEGINS ON PAGE 193

① Discount shop pack of 10 - Priced per package

JOHNSON/EVINRUDE (OMC/BRP) Cooling System











OUTBOARD

 <p>18-3368 IMPELLER Replaces: 396809</p>	 <p>18-3102 IMPELLER PLATE Replaces: 305303</p>	 <p>18-3103 IMPELLER PLATE Replaces: 303069</p>	 <p>18-3127 IMPELLER PLATE Replaces: 319275</p>															
 <p>18-3182 IMPELLER PLATE Replaces: 317841</p>	 <p>18-3346 CUP & PLATE ASSEMBLY Replaces: 435027</p>	 <p>18-3352 WEAR PLATE Replaces: 325398</p>	 <p>18-3359 WEAR PLATE Replaces: 328755</p>															
 <p>18-3179 WATER PUMP CUP Replaces: 324097</p>	 <p>18-3455 INSERT CUP Replaces: 340619 For: 40, 50, 25 Jet, 30 Jet 1995-Up, E-Tec 40/50/60 HP All</p>	 <p>IMPELLER KEYS</p> <table border="1"> <thead> <tr> <th>Part #</th> <th>Replaces:</th> <th>Std. Pkg.</th> </tr> </thead> <tbody> <tr> <td>18-3295 ③</td> <td>330619</td> <td>3</td> </tr> <tr> <td>18-3138 ① ③</td> <td>334897</td> <td>2</td> </tr> <tr> <td>18-3108</td> <td>308928</td> <td>1</td> </tr> <tr> <td>18-3299 ② ③</td> <td>331107</td> <td>5</td> </tr> </tbody> </table> <p>① PKG OF 2 ② PKG OF 3</p>	Part #	Replaces:	Std. Pkg.	18-3295 ③	330619	3	18-3138 ① ③	334897	2	18-3108	308928	1	18-3299 ② ③	331107	5	 <p>18-3326 IMPELLER KEY Replaces: 300611</p>
Part #	Replaces:	Std. Pkg.																
18-3295 ③	330619	3																
18-3138 ① ③	334897	2																
18-3108	308928	1																
18-3299 ② ③	331107	5																
 <p>18-3358 INSERT CUP Replaces: 328751</p>	 <p>18-3129 WATER PUMP HOUSING Replaces: 435673</p>	 <p>18-3405 WATER PUMP HOUSING Replaces: 435959</p>	 <p>18-3180 WATER PUMP HOUSING Replaces: 435390</p>															
 <p>18-3336 WATER PUMP HOUSING Replaces: 384087</p>	 <p>18-3363 WATER PUMP HOUSING Replaces: 330560</p>	 <p>18-3367 WATER PUMP HOUSING Replaces: 393632</p>																

APPLICATION BEGINS ON PAGE 193

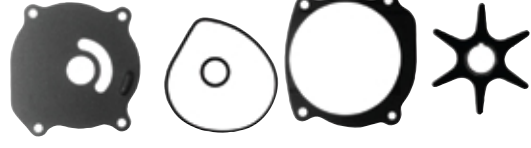
③ This product is priced per piece. To order priced per package, please add -9 to the part number.

 <p>18-3126 WEAR PLATE Replaces: 321940</p>	 <p>18-3178 WEAR PLATE Replaces: 318995</p>	 <p>18-3343 WEAR PLATE Replaces: 320981</p>																																																									
 <p>18-3201 IMPELLER REPAIR KIT — CONTAINS —</p> <table border="1"> <thead> <tr> <th>Part #</th> <th>Desc.</th> <th>O.E. #</th> <th>Qty.</th> </tr> </thead> <tbody> <tr> <td>18-3001</td> <td>Impeller</td> <td>277181, 434424</td> <td>1</td> </tr> </tbody> </table>		Part #	Desc.	O.E. #	Qty.	18-3001	Impeller	277181, 434424	1	 <p>18-3202 IMPELLER REPAIR KIT — CONTAINS —</p> <table border="1"> <thead> <tr> <th>Part #</th> <th>Desc.</th> <th>O.E. #</th> <th>Qty.</th> </tr> </thead> <tbody> <tr> <td>18-3001</td> <td>Impeller</td> <td>277181, 434424</td> <td>1</td> </tr> <tr> <td>18-3102</td> <td>Impeller Plate</td> <td>305303</td> <td>1</td> </tr> </tbody> </table>		Part #	Desc.	O.E. #	Qty.	18-3001	Impeller	277181, 434424	1	18-3102	Impeller Plate	305303	1																																				
Part #	Desc.	O.E. #	Qty.																																																								
18-3001	Impeller	277181, 434424	1																																																								
Part #	Desc.	O.E. #	Qty.																																																								
18-3001	Impeller	277181, 434424	1																																																								
18-3102	Impeller Plate	305303	1																																																								
 <p>18-3203 IMPELLER REPAIR KIT — CONTAINS —</p> <table border="1"> <thead> <tr> <th>Part #</th> <th>Desc.</th> <th>O.E. #</th> <th>Qty.</th> </tr> </thead> <tbody> <tr> <td>18-3002</td> <td>Impeller</td> <td>375638</td> <td>1</td> </tr> <tr> <td>18-3103</td> <td>Impeller Plate</td> <td>303069</td> <td>1</td> </tr> </tbody> </table>		Part #	Desc.	O.E. #	Qty.	18-3002	Impeller	375638	1	18-3103	Impeller Plate	303069	1	 <p>18-3210 IMPELLER REPAIR KIT — CONTAINS —</p> <table border="1"> <thead> <tr> <th>Part #</th> <th>Desc.</th> <th>O.E. #</th> <th>Qty.</th> </tr> </thead> <tbody> <tr> <td>18-3043</td> <td>Impeller</td> <td>389642</td> <td>1</td> </tr> <tr> <td>18-2536</td> <td>Rubber Seal</td> <td>321120</td> <td>1</td> </tr> <tr> <td>18-2557</td> <td>Impeller Gasket</td> <td>324701, 338484</td> <td>1</td> </tr> <tr> <td>18-7158</td> <td>O-Ring</td> <td>310967, 310585</td> <td>1</td> </tr> </tbody> </table>		Part #	Desc.	O.E. #	Qty.	18-3043	Impeller	389642	1	18-2536	Rubber Seal	321120	1	18-2557	Impeller Gasket	324701, 338484	1	18-7158	O-Ring	310967, 310585	1																								
Part #	Desc.	O.E. #	Qty.																																																								
18-3002	Impeller	375638	1																																																								
18-3103	Impeller Plate	303069	1																																																								
Part #	Desc.	O.E. #	Qty.																																																								
18-3043	Impeller	389642	1																																																								
18-2536	Rubber Seal	321120	1																																																								
18-2557	Impeller Gasket	324701, 338484	1																																																								
18-7158	O-Ring	310967, 310585	1																																																								
 <p>18-3211 IMPELLER REPAIR KIT — CONTAINS —</p> <table border="1"> <thead> <tr> <th>Part #</th> <th>Desc.</th> <th>O.E. #</th> <th>Qty.</th> </tr> </thead> <tbody> <tr> <td>18-3059</td> <td>Impeller</td> <td>395864, 397131, 435821</td> <td>1</td> </tr> <tr> <td>18-2536</td> <td>Rubber Seal</td> <td>321120</td> <td>1</td> </tr> <tr> <td>18-2557</td> <td>Impeller Gasket</td> <td>324701, 338484</td> <td>1</td> </tr> <tr> <td>18-3299</td> <td>Impeller Key</td> <td>331107</td> <td>1</td> </tr> <tr> <td>18-7158</td> <td>O-Ring</td> <td>310967, 310585</td> <td>1</td> </tr> <tr> <td>18-3138</td> <td>Impeller Key</td> <td>334897</td> <td>1</td> </tr> </tbody> </table>		Part #	Desc.	O.E. #	Qty.	18-3059	Impeller	395864, 397131, 435821	1	18-2536	Rubber Seal	321120	1	18-2557	Impeller Gasket	324701, 338484	1	18-3299	Impeller Key	331107	1	18-7158	O-Ring	310967, 310585	1	18-3138	Impeller Key	334897	1	 <p>18-3238 WATER PUMP KIT Replaces: 388891 — CONTAINS —</p> <table border="1"> <thead> <tr> <th>Part #</th> <th>Desc.</th> <th>O.E. #</th> <th>Qty.</th> </tr> </thead> <tbody> <tr> <td>18-3051</td> <td>Impeller</td> <td>395289</td> <td>1</td> </tr> <tr> <td>18-0446</td> <td>Water Pump Gasket</td> <td>323311</td> <td>1</td> </tr> <tr> <td>18-0445</td> <td>Water Pump Gasket</td> <td>323312</td> <td>1</td> </tr> <tr> <td>18-2030</td> <td>Oil Seal</td> <td>321786</td> <td>1</td> </tr> <tr> <td>18-7105</td> <td>O-Ring</td> <td>311338</td> <td>2</td> </tr> <tr> <td>18-3133</td> <td>Stainless Steel Bolt</td> <td>331979</td> <td>4</td> </tr> </tbody> </table>		Part #	Desc.	O.E. #	Qty.	18-3051	Impeller	395289	1	18-0446	Water Pump Gasket	323311	1	18-0445	Water Pump Gasket	323312	1	18-2030	Oil Seal	321786	1	18-7105	O-Ring	311338	2	18-3133	Stainless Steel Bolt	331979	4
Part #	Desc.	O.E. #	Qty.																																																								
18-3059	Impeller	395864, 397131, 435821	1																																																								
18-2536	Rubber Seal	321120	1																																																								
18-2557	Impeller Gasket	324701, 338484	1																																																								
18-3299	Impeller Key	331107	1																																																								
18-7158	O-Ring	310967, 310585	1																																																								
18-3138	Impeller Key	334897	1																																																								
Part #	Desc.	O.E. #	Qty.																																																								
18-3051	Impeller	395289	1																																																								
18-0446	Water Pump Gasket	323311	1																																																								
18-0445	Water Pump Gasket	323312	1																																																								
18-2030	Oil Seal	321786	1																																																								
18-7105	O-Ring	311338	2																																																								
18-3133	Stainless Steel Bolt	331979	4																																																								

APPLICATION BEGINS ON PAGE 193

① Items ending in "D" are Display Packaged - Regular number is Non-Display

JOHNSON/EVINRUDE (OMC/BRP) Cooling System



OUTBOARD



**18-3453
WATER PUMP KIT**
Replaces: 5006511
For: E-Tec 40/50/60 HP All



**18-3454
WATER PUMP KIT**
Replaces: 438592
For: 40, 50, 25 Jet, 30 Jet 1995-Up



**18-3325
WATER PUMP KIT**
Replaces: 387326

— CONTAINS —

Part #	Desc.	O.E. #	Qty.
18-7134	O-Ring	339543	1
18-3108	Flywheel Key	308928	1
18-3337	Grommet	315837	1
18-3083	Impeller	377230	1
18-3343	Impeller Plate	320981	1
18-2705	Grommet	315748	1



**18-3327
WATER PUMP KIT**
With Housing
Replaces: 394711, 386697, 391698

— CONTAINS —

Part #	Desc.	O.E. #	Qty.
18-3050	Impeller	386084	1
18-3180	Housing	435390	1
18-3178	Wear Plate	318995	1
18-3179	Water Pump Cup	324097	1
18-3329	Grommet	302497	1
18-2392	Grommet	327035	1
18-2025	Oil Seal	318972	1
18-7116	O-Ring	303097	1
18-7139	O-Ring	319085	1
18-3326	Pin	300771	1
18-3369	Stainless Steel Bolt	319126	4



**18-3376
WATER PUMP KIT**
Without Housing
Replaces: 384956

— CONTAINS —

Part #	Desc.	O.E. #	Qty.
18-3083	Impeller	377230	1
18-3343	Impeller Plate	320981	1
18-3108	Flywheel Key	308928	1
18-3337	Grommet	315837	1
18-7134	O-Ring	339543	1
18-2705	Grommet	315748	1
18-3136	Screw (Long)	324430	2
18-3369	Stainless Steel Bolt	319126	2



**18-3377
WATER PUMP KIT**
Without Housing
Replaces: 382468

— CONTAINS —

Part #	Desc.	O.E. #	Qty.
18-3002	Impeller	375638	1
18-3103	Impeller Plate	303069	1
18-3329	Water Tube Grommet	302497	1
18-3326	Pin	300771	1

**18-3378
WATER PUMP KIT**
With Housing
Replaces: 391635

— CONTAINS —

Part #	Desc.	O.E. #	Qty.
18-3055	Impeller	389589	1
18-3343	Impeller Plate	320981	1
18-3336	Housing	384087	1
18-2709	Wear Plate Gasket	336530	1
18-3365	Stainless Steel Bolt	909533	2
18-3369	Stainless Steel Bolt	319126	2
18-2705	Seal	315748	1
18-3337	Water Tube Grommet	315837	1
18-7134	O-Ring	303059	1



APPLICATION BEGINS ON PAGE 193



**18-3379
WATER PUMP KIT**
Without Housing
Replaces: 390381

— CONTAINS —

Part #	Desc.	O.E. #	Qty.
18-3366	Impeller	390286	1
18-3352	Impeller Plate	325398	1
18-3354	Water Pump Gasket	325399	2
18-3332	Grommet	304056	1



**18-3380
WATER PUMP KIT**
Without Housing
Replaces: 390770

— CONTAINS —

Part #	Desc.	O.E. #	Qty.
18-3055	Impeller	389589	1
18-3343	Impeller Plate	320981	1
18-2709	Wear Plate Gasket	336530	1
18-3365	Stainless Steel Bolt	909533	2
18-3136	Stainless Steel Bolt	319126	2
18-2705	Seal	315748	1
18-3337	Water Tube Grommet	315837	1
18-7134	O-Ring	303059	1



**18-3381
WATER PUMP KIT**
Without Housing
Replaces: 393509

— CONTAINS —

Part #	Desc.	O.E. #	Qty.
18-3051	Impeller	395289	1
18-3359	Impeller Plate	328755	1
18-0124	Impeller Plate Gasket	325537	1
18-3358	Water Pump Cup	328751	1
18-2539	Rubber Seal	328753	1
18-3329	Grommet	302497	1
18-7100	O-Ring	301877	1
18-7105	O-Ring	311338	2
18-7146	O-Ring	554545	1
18-3133	Stainless Steel Bolt	331979	6



**18-3382
WATER PUMP KIT**
With Housing
Replaces: 393630

— CONTAINS —

Part #	Desc.	O.E. #	Qty.
18-3051	Impeller	395289	1
18-3359	Impeller Plate	328755	1
18-3367	Housing	393632	1
18-3358	Water Pump Cup	328751	1
18-0124	Impeller Plate Gasket	325537	1
18-3329	Grommet	302497	1
18-7100	O-Ring	301877	1
18-7105	O-Ring	311338	2
18-7146	O-Ring	554545	1
18-3133	Stainless Steel Bolt	331979	6



**18-3383
WATER PUMP KIT**
With Housing
Replaces: 395270

— CONTAINS —

Part #	Desc.	O.E. #	Qty.
18-3051	Impeller	395289	1
18-3363	Housing	330560	1
18-3358	Water Pump Cup	328751	1
18-3360	Impeller Housing Gasket	329390	1
18-3329	Grommet	302497	1
18-3133	Stainless Steel Bolt	331979	4



**18-3384
WATER PUMP KIT**
Without Housing
Replaces: 386124

— CONTAINS —

Part #	Desc.	O.E. #	Qty.
18-7158	O-Ring	310585	1
18-3108	Flywheel Key	308928	1
18-3043	Impeller	389642	1
18-3182	Impeller Plate	317841	1
18-2026	Oil Seal	321453	1
18-3135	Screw	306643	2
18-3136	Screw	323626	4
18-2389	Grommet	314832	2

JOHNSON/EVINRUDE (OMC/BRP)

Cooling System



OUTBOARD



**18-3385
WATER PUMP KIT**
Without Housing
Replaces: 396932

— CONTAINS —

Part #	Desc.	O.E. #	Qty.
18-3368	Impeller	396809	1
18-3343	Impeller Plate	320981	1
18-2705	Seal	315748	1
18-7481	Rubber Seal	324981	1
18-7134	O-Ring	303059	1
18-3337	Water Tube Grommet	315837	1
18-3365	Stainless Steel Bolt	909533	2
18-3369	Stainless Steel Bolt	319126	2



**18-3387
WATER PUMP KIT**
Without Housing
Replaces: 432956

— CONTAINS —

Part #	Desc.	O.E. #	Qty.
18-2703	Grommet	314008	1
18-3053	Impeller	396725	1
18-2705	Seal	315748	1
18-3133	SS Bolt	908158	4
18-7174	O-Ring	326649	1
18-7481	O-Ring	324981	1
18-2709	Wear Plate Gasket	336530	1
18-3126	Wear Plate	321940	1
18-3127	Impeller Plate	319275	1
18-3138	Impeller Key	334897	1
18-3299	Flywheel Key	331107	1
18-3153	Stainless Steel Bolt	908158	1



**18-3388
WATER PUMP KIT**
Without Housing
Replaces: 389143

— CONTAINS —

Part #	Desc.	O.E. #	Qty.
18-0969	Impeller Housing Gasket	319586	1
18-3108	Stainless Steel Key	323950	1
18-2703	Grommet	314008	1
18-3127	Impeller Plate	319275	1
18-2705	Seal	315748	1
18-3082	Impeller	382547	1
18-3153	Stainless Steel Bolt	334597	1
18-2709	Wear Plate Gasket	336530	1
18-3133	Stainless Steel Bolt	331979	4
18-3126	Wear Plate	321940	1



**18-3389
WATER PUMP KIT**
With Housing
Replaces: 436957

— CONTAINS —

Part #	Desc.	O.E. #	Qty.
18-7481	O-Ring	324981	1
18-2703	Grommet	314008	1
18-3053	Impeller	396725	1
18-3127	Impeller Plate	319275	1
18-2705	Seal	315748	1
18-3133	Stainless Steel Bolt	908158	1
18-3299	Flywheel Key	331107	1
18-7174	O-Ring	326649	1
18-2709	Wear Plate Gasket	336530	1
18-3129	Housing	435673	1
18-3138	Impeller Key	334897	1
18-3126	Wear Plate	321940	1



**18-3390
WATER PUMP KIT**
Without Housing
Replaces: 395060

— CONTAINS —

Part #	Desc.	O.E. #	Qty.
18-3059	Impeller	397131, 435821	1
18-2557	Impeller Gasket	324701, 338484	1
18-3299	Impeller Key	331107	1
18-7158	O-Ring	310967, 310585	1
18-3135	Stainless Steel Screw	306643	2
18-2703	Grommet	314008	1
18-2704	Grommet	320943	1
18-2706	Grommet	321008	1
18-3136	Stainless Steel Bolt	323626	4
18-2769	Rubber Seal	332000	1
18-3133	Stainless Steel Bolt	331979	4
18-3346	Cup Plate Assy.	435027	1
18-3138	Impeller Key	334897	1



**18-3391
WATER PUMP KIT**
Without Housing
Replaces: 395072

— CONTAINS —

Part #	Desc.	O.E. #	Qty.
18-3346	Cup & Plate Assy.	435027	1
18-2769	O-Ring	332000	1
18-2557	Impeller Plate Gasket	338484, 324701	1
18-2704	Grommet	320943	1
18-3136	Stainless Steel Bolt	323626	4
18-3299	Flywheel Key	331107	1
18-3153	Stainless Steel Bolt	908158	1

APPLICATION BEGINS ON PAGE 193

**18-3392
WATER PUMP KIT**
Without Housing
Replaces: 434421



— CONTAINS —

Part #	Desc.	O.E. #	Qty.
18-3059	Impeller	395864, 397131, 435821	1
18-3346	Cup & Plate Assy.	435027	1
18-3299	Impeller Key	331107	1
18-7158	O-Ring	310967, 310585	1
18-3135	Stainless Steel Screw	306643	2
18-2703	Grommet	314008	1
18-2704	Grommet	320943	1
18-2706	Grommet	321008	1
18-3136	Stainless Steel Bolt	323626	4
18-2769	Rubber Seal	332000	1
18-2557	Impeller Gasket	324701, 338484	1
18-3133	Stainless Steel Bolt	331979	4

**18-3393
WATER PUMP KIT**
Without Housing
Replaces: 395073



— CONTAINS —

Part #	Desc.	O.E. #	Qty.
18-3043	Impeller	389642	1
18-2557	Impeller Gasket	324701, 338484	1
18-3346	Cup & Plate Assy.	435027	1
18-3108	Water Pump Key	323950	1
18-0110	Shift Housing Gasket	324670	1
18-7158	O-Ring	310967, 310585	1
18-3135	Stainless Steel Screw	306643	2
18-2703	Grommet	314008	1
18-2704	Grommet	320943	1
18-2706	Grommet	321008	1
18-3136	Stainless Steel Bolt	323626	4
18-2769	O-Ring	332000	1
18-7143	O-Ring	322501	1
18-3133	Stainless Steel Bolt	331979	4

**18-3394
WATER PUMP KIT**
Without Housing
Replaces: 433548



— CONTAINS —

Part #	Desc.	O.E. #	Qty.
18-7481	O-Ring	324981	1
18-2708	Grommet	333758	1
18-2709	Wear Plate Gasket	336530	1
18-3104	Impeller	432941	1
18-3138	Impeller Key	334897	1
18-2705	Seal	315748	1
18-3133	Stainless Steel Bolt	331979	4
18-3126	Wear Plate	321940	1

**18-3399
WATER PUMP KIT**
With Housing
Replaces: 396933



— CONTAINS —

Part #	Desc.	O.E. #	Qty.
18-7134	O-Ring	303059	1
18-3337	Grommet	315837	1
18-3368	Impeller	396809	1
18-2709	Wear Plate Gasket	336530	1
18-3369	Screw (Short)	319126	2
18-2705	Seal	315748	1
18-3336	Housing	384087	1
18-3365	Screw (Long)	909533	2
18-3343	Wear Plate	320981	1

JOHNSON/EVINRUDE (OMC/BRP) Cooling System



OUTBOARD



**18-3400
WATER PUMP KIT**
Without Housing
Replaces: 391698

— CONTAINS —

Part #	Desc.	O.E. #	Qty.
18-3050	Impeller	386084	1
18-3178	Impeller Plate	318995	1
18-3179	Water Pump Cup	324097	1
18-3329	Grommet	302497	1
18-2392	Grommet	327035	1
18-2025	Oil Seal	318972	1
18-7116	O-Ring	303097	1
18-3369	Screw	319126	4
18-3326	Pin	300771	1
18-7139	O-Ring	319085	1



**18-3401
WATER PUMP KIT**
Without Housing
Replaces: 395271

— CONTAINS —

Part #	Desc.	O.E. #	Qty.
18-3051	Impeller	395289	1
18-3360	Gasket	329398	1
18-3358	Cup	328773	1
18-7440-1	O-Ring	301967	2
18-2013	Oil Seal	321786	1
18-3329	Grommet	302497	1
18-0108	Gasket	324449	1
18-3133	Stainless Steel Bolt	331979	4



**18-3402
WATER PUMP KIT**
Without Housing
Replaces: 382296

— CONTAINS —

Part #	Desc.	O.E. #	Qty.
18-3003	Impeller	377178	1
18-3102	Impeller Plate	305303	1
18-2891	Gasket	303339	1
18-3326	Pin	300771	1
18-3329	Grommet	302497	1
18-2023	Oil Seal	313282	1

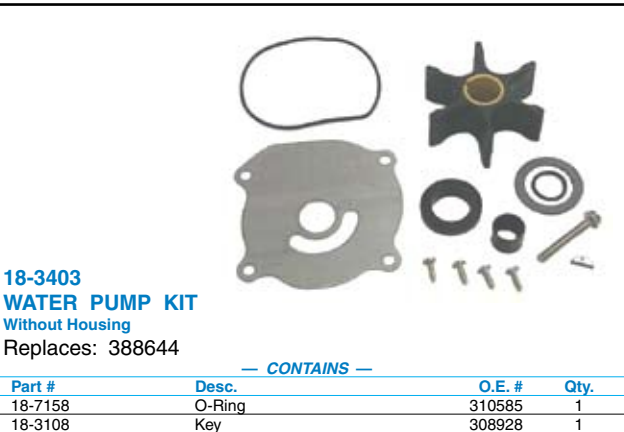

**18-3403
WATER PUMP KIT**
Without Housing
Replaces: 388644

— CONTAINS —

Part #	Desc.	O.E. #	Qty.
18-7158	O-Ring	310585	1
18-3108	Key	308928	1
18-2703	Grommet	314008	1
18-3135	Screw	306643	4
18-2026	Seal	321453	1
18-3136	Housing Screw	323626	1
18-3043	Impeller	389642	1
18-3346	Cup & Plate Assembly	435027	1
18-2536	Gasket	321120	1
18-2704	Grommet	320943	1

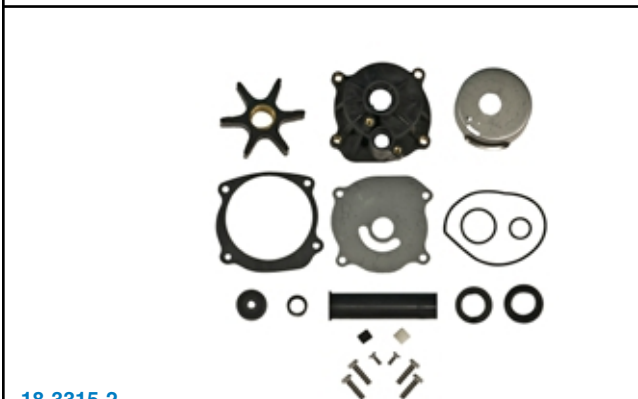

**18-3315-2
WATER PUMP KIT**

Replaces: 435929, 5001595
For: 90/115SL (1995-UP), 120/125ESX (1993-94),
120/130/140/150/175/V-6/V-8 (1993-UP)

— CONTAINS —

Part #	Desc.	O.E. #	Qty.
18-2557	Gasket	324701	1
18-3405	Housing, WP	435485	1



STAINLESS STEEL BOLTS

Part #	O.E. #	Size
18-3133	331979	1/4 x 20 x 1 1/16"
18-3134	324960	1/4 x 20 x 1"
18-3135 ①③	306643	1/8 x 20 x 1/2"
18-3136 ①③	323626	1/4 x 20 x 1 3/4"
18-3153	908158	1/4 x 20 x 1/2"
18-3365	909533	1/4 x 20 x 1"
18-3369	319126	1/4 x 20 x 1"
18-4276 ②③	324334	1/4 x 20 x 1 1/32"
18-4277 ②③	324430	1/4 x 20 x 2"

① Std. Pkg. of 2 ② Std. Pkg. of 5

APPLICATION BEGINS ON NEXT PAGE

③ This product is priced per piece. To order priced per package, please add -9 to the part number.



JOHNSON/EVINRUDE (OMC/BRP) Cooling System

Horsepower	Year	Impeller	Impeller Plate	Plate & Cup	Cup	Repair Kit	Pump Kit w/o Hsg.	Pump Kit W/Hsg.	Housing Kit
2 Jr. Colt	1985-90	18-3090	—	—	—	—	—	—	—
2.5	1987-06	18-3015	—	—	—	—	—	—	—
3	1952-78	18-3001	—	—	—	18-3201	—	—	—
3.5	1987-06	18-3015	—	—	—	—	—	—	—
4	1969-72	18-3001	—	—	—	18-3201	—	—	—
4 ⑦	1973-83	18-3001	—	—	—	18-3201	—	—	—
4 ⑧	1976-80	18-3090	—	—	—	—	—	—	—
4 Deluxe	1980-97	18-3091	—	—	—	—	—	—	—
4 Ultra Excel	1987-06	18-3015	—	—	—	—	—	—	—
4.5	1980-97	18-3091	—	—	—	—	—	—	—
5	1965-68	18-3001	—	—	—	—	—	—	—
5 (4-Stroke)	1998-Up	18-3091	—	—	—	—	—	—	—
5.5	1954-64	18-3001	18-3102	—	—	18-3202	—	—	—
6	1952-78	18-3001	18-3102	—	—	18-3202	—	—	—
6	1979	18-3090	—	—	—	—	—	—	—
6	1984-97	18-3091	—	—	—	—	—	—	—
6 (4-Stroke)	1998-Up	18-3091	—	—	—	—	—	—	—
7.5	1954-58	18-3001	18-3102	—	—	18-3202	—	—	—
8 (2-Stroke)	1986-97	18-3091	—	—	—	—	—	—	—
9.5	1964-73	18-3003	18-3102	—	—	—	18-3402	—	—
10	1958-63	18-3003	18-3102	—	—	—	18-3402	—	—
10	1949-57	18-3002	18-3103	—	—	18-3203	18-3377	—	—
9.9/15	1974-Up	18-3050	18-3178	—	18-3179	—	18-3400	18-3327	18-3180
9.9/15 (4-Stroke)	1995-Up	18-3050	18-3178	—	18-3179	—	18-3400	18-3327	18-3180
15,18	1953-65	18-3002	—	—	—	18-3203	18-3377	—	—
20	1966-73	18-3002	—	—	—	18-3203	18-3377	—	—
20	1982-84	18-3051	—	—	18-3358	—	18-3401	18-3383	18-3363
20	1985-Up	18-3051	18-3359	—	18-3358	—	18-3381	18-3382	18-3367
25	1951-55	18-3006	—	—	—	—	—	—	—
25	1969-78	18-3002	18-3103	—	—	18-3203	18-3377	—	—
25	1979-84	18-3051	—	—	18-3358	—	18-3401	18-3383	18-3363
25	1985-Up	18-3051	18-3359	—	18-3358	—	18-3381	18-3382	18-3367
28	1962-64	18-3006	—	—	—	—	—	—	—
28	1978-Up	18-3051	—	—	18-3358	—	18-3401	18-3383	18-3363
30	1951-57	18-3006	—	—	—	—	—	—	—
30	1984-Up	18-3051	18-3359	—	18-3358	—	18-3381	18-3382	18-3367
33	1962-71	18-3006	—	—	—	—	—	—	—
35	1951-57	18-3006	—	—	—	—	—	—	—
35	1958-59	18-3083	—	—	—	—	—	—	—
35	1976-77	18-3006	—	—	—	—	—	—	—
35	1978-79	18-3051	—	—	—	—	18-3238	—	—
35	1980-82	18-3051	N/A	—	18-3358	—	—	18-3382	18-3367
35	1983-Up	18-3051	18-3359	—	18-3358	—	—	—	—
35 Jet	1992-93	18-3104	—	—	—	—	18-3394	—	—
40	1960-70	18-3083	—	—	—	—	—	—	—
40	1971-73	18-3006	—	—	—	—	—	—	—
40 Comm.	1981-90	18-3366	18-3352	—	—	—	18-3379	—	—
40	1984-85	18-3055	18-3343	—	—	—	18-3385	18-3399	18-3336
40	1986-88	18-3368	18-3343	—	—	—	18-3385	18-3399	18-3336
40	1989-98	18-3104	—	—	—	—	18-3394	—	—
40	1999-Up	18-3053	—	—	—	—	18-3394	—	—
45/55 Comm.	1985	18-3055	—	—	—	—	18-3380	—	18-3336
45/55	1989	18-3368	18-3343	—	—	—	18-3385	18-3399	18-3336
45/55 Comm.	1986-88,	18-3368	—	—	—	—	18-3385	18-3399	18-3336
48	1987-88	18-3368	18-3343	—	—	—	18-3385	18-3399	18-3336
48	1989-96	18-3104	18-3127	—	—	—	18-3394	—	—
50	1971-78	18-3083	18-3343	—	—	—	18-3376	—	—
50	1979-85	18-3055	18-3343	—	—	—	18-3380	18-3378	18-3336
50	1986-88	18-3368	18-3343	—	—	—	18-3385	18-3399	18-3336
50	1989-98	18-3104	—	—	—	—	18-3394	—	—
55	1968-69	18-3082	—	—	—	—	—	—	—
55	1976-78	18-3083	—	—	—	—	—	—	18-3336
55	1979-85	18-3055	18-3343	—	—	—	18-3380	18-3378	18-3336
60	1964-67	18-3005	—	—	—	—	—	—	—
60	1970-71	18-3082	—	—	—	—	—	—	—
60	1980-85	18-3055	—	—	—	—	18-3380	18-3378	18-3336
60	1986-94	18-3053	18-3127	—	—	—	18-3387	18-3389	—
60	1995-Up	18-3053	18-3127	—	—	—	18-3387	—	—

① Except chrome pumps ③ "S" Suffix ⑤ Except 1993-94 25" & 30" V6 & V8
 ② Except SL models 1995 & Up/FFI models ④ "F" Suffix ⑦ For water pumps using 1 water tube ⑧ 90 degree gearcase

OUTBOARD

JOHNSON/EVINRUDE (OMC/BRP)

Cooling System



Horsepower	Year	Impeller	Impeller Plate	Plate & Cup	Cup	Repair Kit	Pump Kit w/o Hsg.	Pump Kit W/Hsg.	Housing Kit
65	1968	18-3005	—	—	—	—	—	—	—
65	1972-73	18-3082	—	—	—	—	—	—	—
65 Comm.	1984-94	18-3053	18-3127	—	—	—	18-3387	18-3389	—
65 Comm.	1995-Up	18-3053	18-3127	—	—	—	18-3387	—	—
70	1974-78	18-3082	18-3127	—	—	—	18-3388	—	—
70	1979-94	18-3053	18-3127	—	—	—	18-3387	18-3389	—
70	1995-Up	18-3053	18-3127	—	—	—	18-3387	—	—
75	1960-65	18-3005	—	—	—	—	—	—	—
75	1974-78	18-3082	18-3127	—	—	—	18-3388	—	—
75	1979-88	18-3053	18-3127	—	—	—	18-3387	18-3389	18-3129
80	1966-67	18-3005	—	—	—	—	—	—	—
85	1968	18-3005	—	—	—	—	—	—	—
85	1969-72	18-3044	18-3182	—	—	—	—	—	—
85	1973-77	18-3043	18-3182	—	—	—	18-3384	—	—
85	1978	18-3043	—	18-3346	—	—	—	18-3393⑦	18-3391
85	1979-95	18-3059	—	18-3346	—	18-3211	18-3390	18-3392	18-3391
90	1964-68	18-3005	—	—	—	—	—	—	—
90	1979-Up	18-3059	—	18-3346	—	18-3211	18-3390	18-3392②	18-3391
90 SL,DI	1995 & UP	18-3059	—	18-3346	—	18-3211	18-3390	18-3315-2	18-3405
100	1969-72	18-3044	—	—	—	—	—	—	—
100	1979-Up	18-3059	—	18-3346	—	18-3211	18-3390	18-3392	18-3391
100 Comm. ①	1984-Up	18-3059	—	18-3346	—	18-3211	18-3390	18-3392	18-3391
105 Comm.	1998-2001	18-3059	—	18-3346	—	18-3211	18-3390	18-3315-2	18-3405
115	1969-70	18-3044	—	—	—	—	—	—	—
115	1973-76	18-3043	—	—	—	—	18-3384	—	—
115	1977-78	18-3043	—	18-3346	—	—	—	18-3393⑦	18-3391
115	1979-Up	18-3059	—	18-3346	—	18-3211	18-3390	18-3392②	18-3391
115 SL,DL	1995 & UP	18-3059	—	18-3346	—	18-3211	18-3390	18-3315-2	18-3405
120 25" ④	1993-2000	18-3059	—	18-3346	—	18-3211	18-3390	18-3315-2	18-3405
125	1971-72	18-3044	—	—	—	—	—	—	—
125 ESX 25" ③	1993-94	18-3059	—	18-3346	—	18-3211	18-3390	18-3392	18-3391
125 ESX 25"	1994-95	18-3059	—	18-3346	—	18-3211	18-3390	18-3392	18-3391
125 ESX 25" ④	1993-94	18-3059	—	18-3346	—	18-3211	18-3390	—	—
130	1997 & UP	18-3059	—	18-3346	—	18-3211	18-3390	18-3315-2	18-3405
130 25"	1994-2000	18-3059	—	18-3346	—	18-3211	18-3390	18-3315-1	18-3405
135	1973-75	18-3043	18-3182	—	—	18-3210	18-3384	—	—
135	1976	18-3043	18-3182	—	—	—	—	—	—
135 25"	2001	18-3059	—	18-3346	—	18-3211	18-3390	18-3315-2	18-3405
140	1977-78	18-3043	—	18-3346	—	—	—	18-3393⑦	18-3391
140	1979-Up	18-3059	—	18-3346	—	18-3211	18-3390	18-3392	18-3391
140 25" ④	1993	18-3059	—	18-3346	—	18-3211	18-3390	18-3315-2	18-3405
140 25"	1994-2000	18-3059	—	18-3346	—	18-3211	18-3390	18-3315-2	18-3405
150	1976-78	18-3043	—	18-3346	—	18-3210	—	18-3393⑦	18-3391
150	1979-Up	18-3059	—	18-3346	—	18-3211	18-3390	18-3392	18-3391
150 20"	1993 & UP	18-3059	—	18-3346	—	18-3211	18-3390	18-3392	18-3391
150 SL 20"	1994-98	18-3059	—	18-3346	—	18-3211	18-3390	18-3315-2	18-3405
150 EL 20"	1996-98	18-3059	—	18-3346	—	18-3211	18-3390	18-3315-2	18-3405
150 25"	1993 & UP	18-3059	—	18-3346	—	18-3211	18-3390	18-3315-2	18-3405
150 DI	1997 & UP	18-3059	—	18-3346	—	18-3211	18-3390	18-3315-2	18-3405
150	2000 & UP	18-3059	—	18-3346	—	18-3211	18-3390	18-3315-2	18-3405
175	1976-78	18-3043	—	18-3346	—	18-3210	—	18-3393⑦	18-3391
175 SL 20"	1994-98	18-3059	—	18-3346	—	18-3211	18-3390	18-3315-2	18-3405
175 EL 20"	1996-98	18-3059	—	18-3346	—	18-3211	18-3390	18-3315-2	18-3405
175 25"	1993 & UP	18-3059	—	18-3346	—	18-3211	18-3390	18-3315-2	18-3405
175 DI	1997 & UP	18-3059	—	18-3346	—	18-3211	18-3390	18-3315-2	18-3405
175	2000 & UP	18-3059	—	18-3346	—	18-3211	18-3390	18-3315-2	18-3405
200	1976-78	18-3043	—	18-3346	—	—	—	18-3393⑦	18-3391
200 Comm.	1990	18-3059	—	18-3346	—	18-3211	18-3390	18-3392	18-3391
200 25" & 30"	1993-97	18-3059	—	18-3346	—	18-3211	18-3390	18-3315-2	18-3405
225 20"	1993 & UP	18-3059	—	18-3346	—	18-3211	18-3390	18-3392	18-3391
225 25" & 30"	1993-97	18-3059	—	18-3346	—	18-3211	18-3390	18-3315-2	18-3405
235	1978	18-3043	—	18-3346	—	—	—	18-3393⑦	18-3391
235	1979-Up	18-3059	—	18-3346	—	18-3211	18-3390	18-3392	18-3391
V4 Cross 20" & 25"	1993 & UP	18-3059	—	18-3346	—	18-3211	18-3390	18-3392	18-3391
V4 Loop 20"	1993 & UP	18-3059	—	18-3346	—	18-3211	18-3390	18-3392	18-3391
V4,V6,V8 ⑤	1982-94	18-3059	—	18-3346	—	18-3211	18-3390	18-3392	18-3391
V6,V8 20"	1993 & UP	18-3059	—	18-3346	—	18-3211	18-3390	18-3392	18-3391
V6 & V8 25" & 30"	1993 & UP	18-3059	—	18-3346	—	18-3211	18-3390	18-3315-2	18-3405
Sea Drives	1979-Up	18-3059	—	18-3346	—	18-3211	18-3390	18-3392⑥	18-3391

① Except chrome pumps
 ② Except SL models 1995 & Up/FFI models
 ③ "S" Suffix
 ④ "F" Suffix
 ⑤ Except 1993-94 25" & 30" V6 & V8
 ⑥ Except high pressure pumps
 ⑦ For water pumps using 1 water tube
 ⑧ 90 degree gearcase

OUTBOARD

 <p>18-3563 POPPET RELIEF VALVE V-6 Crossflow Replaces: 321027</p>	 <p>18-3564 POPPET RELIEF VALVE V-4 Crossflow Replaces: 318395</p>	 <p>18-1219 GROMMET V-6 Crossflow Replaces: 320880</p>	<p>PKG. OF 2</p>  <p>18-1221 18-1221-9^① RETAINER GASKET V-4/V-6 Loop Charge Replaces: 330273</p>
 <p>18-3562 VALVE CUP V-6 Crossflow Replaces: 321222</p>	 <p>18-1243 VALVE SPRING V-4/V-6 Crossflow Replaces: 317245</p>	 <p>18-1222 THERMOSTAT GASKET V-4/V-6 Loop Charge Replaces: 394408</p>	 <p>18-3567 RUBBER VALVE V-6 Crossflow Replaces: 321221</p>
 <p>18-3565 RETAINER V-6 Crossflow Replaces: 321220</p>	 <p>18-2391 GROMMET V-4 Crossflow Replaces: 321692</p>	 <p>18-3500 THERMOSTAT Replaces: 434137 For: 3 cyl. (1992 & UP), 90° Looper (1990-1992) 140°</p>	
 <p>18-3544 THERMOSTAT Replaces: 435491 Fits: E100 (2004-06), E115 (2002-06), E75 (2002-03), E90 (2002-03), E150 (1993-94), E175 (1993-94), J105 (2003), J115 (2002-06), J150 (1993-94, 2002-06), J175 (1994, 2002-06), J90 (2004-06)</p>	 <p>18-3545 THERMOSTAT Replace: 437090 Fits: E115 (1997), E135, E150, E175 (2000-06)</p>	 <p>18-3546 THERMOSTAT Replaces: 5001036 Fits: E200, E225, E250 (2000-05), J200, J225, J250 (2000-01)</p>	

APPLICATION BEGINS ON PAGE 198

^① Priced per package

JOHNSON/EVINRUDE (OMC/BRP) Cooling System



OUTBOARD

 <p>18-3543 THERMOSTAT Replaces: 393659, 434841, 378065, 508626, 5005440 Fits: 40-250hp E-tech, 6-55hp, Cross V4 & V6, 9.9 4-Stroke (1994-01), 15 4-Stroke (1994-01) 143°</p>	 <p>18-3557 THERMOSTAT Replaces: 396987, 382385 143°</p>	 <p>18-3561 THERMOSTAT Replaces: 436195 143°</p>												
 <p>18-1506 VERNATHERM Replaces: 394411 For: 10/15 (1993-95), 60/125/185 (1989-90), 65 (1987-89), 70/200/225 (1986-90), 120/140/300 (1985-90), 275 (1985-88)</p>	 <p>18-3560 VERNATHERM Replaces: 384719 105° Fits most 3 & 4 cyl., 1985-90</p>	<p>① 18-3669D Display Package</p>  <p>18-3669 THERMOSTAT KIT — CONTENTS —</p> <table border="1"> <thead> <tr> <th>Part #</th> <th>Description</th> <th>O.E. #</th> </tr> </thead> <tbody> <tr> <td>18-3557</td> <td>Thermostat</td> <td>396987</td> </tr> <tr> <td>18-2548</td> <td>Thermostat Cover Gasket</td> <td>332108</td> </tr> <tr> <td>18-0929</td> <td>Thermostat Gasket</td> <td>313416</td> </tr> </tbody> </table>	Part #	Description	O.E. #	18-3557	Thermostat	396987	18-2548	Thermostat Cover Gasket	332108	18-0929	Thermostat Gasket	313416
Part #	Description	O.E. #												
18-3557	Thermostat	396987												
18-2548	Thermostat Cover Gasket	332108												
18-0929	Thermostat Gasket	313416												
<p>① 18-3672D Display Package</p>  <p>18-3672 THERMOSTAT KIT — CONTENTS —</p> <table border="1"> <thead> <tr> <th>Part #</th> <th>Description</th> <th>O.E. #</th> </tr> </thead> <tbody> <tr> <td>18-3553</td> <td>Thermostat</td> <td>434841</td> </tr> <tr> <td>18-0182</td> <td>Thermostat Gasket</td> <td>310058</td> </tr> </tbody> </table>	Part #	Description	O.E. #	18-3553	Thermostat	434841	18-0182	Thermostat Gasket	310058	<p>① 18-3673D Display Package</p>  <p>18-3673 THERMOSTAT KIT V-4 Crossflow</p>	<p>① 18-3674D Display Package</p>  <p>18-3674 THERMOSTAT KIT V-6 Crossflow</p>			
Part #	Description	O.E. #												
18-3553	Thermostat	434841												
18-0182	Thermostat Gasket	310058												
 <p>18-3566 TELL TALE HOSE ELBOW Replaces: 331894</p>	 <p>18-1507 THERMOSTAT SEAL Replaces: 335981 For: 60° V-4 & V-6</p>	 <p>18-1734 THERMOSTAT SEAL Replaces: 334742 For: OMC thermostat application 6, 8, 10, 15, 40, 48, 50 HP (1989-94)</p>												

APPLICATION BEGINS ON PAGE 198

① Items ending in "D" are Display Packaged - Regular number is Non-Display

Crossflow V-4 Engine

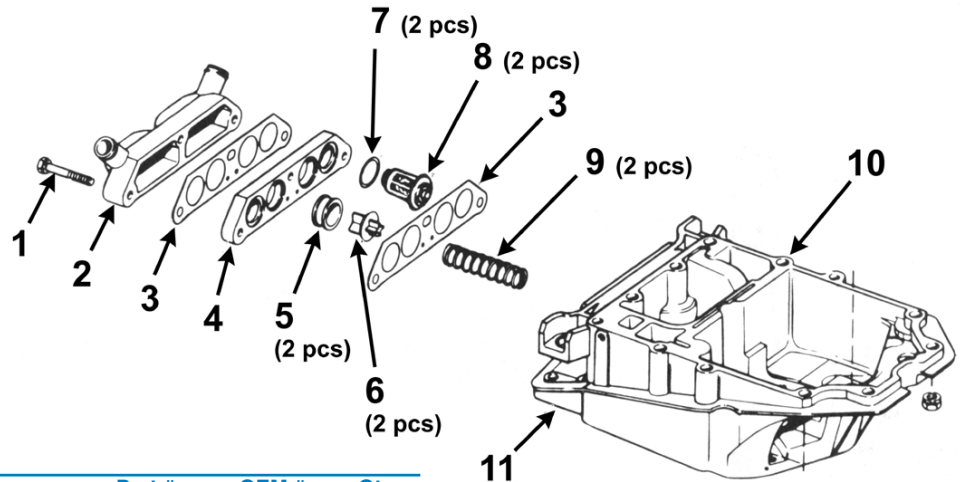

Fig. #	Description	Part #	OEM #	Qty.
1.	Screw Cover	—	305652	3
2.	Cover	—	321690	1
3.	Gasket	18-0977	332369	2
4.	Valve Body	—	321693	1
5.	Grommet	18-2391	321692	2
6.	Valve	18-3564	318395	2
7.	Thermostat Gasket	18-0675	321932	2
			434841,	
8.	Thermostat	18-3543	393659	2
9.	Spring	18-1243	317245	2
10. ①	Adapter to Powerhead Gasket	18-0957	318373	1
10. ②	Adapter to Powerhead Gasket	18-2864	321727	1
11.	Adapter	—	331039	1

① Year/Models 1973-1977 ② Year/Models 1978-1996

Crossflow V-6 Engine

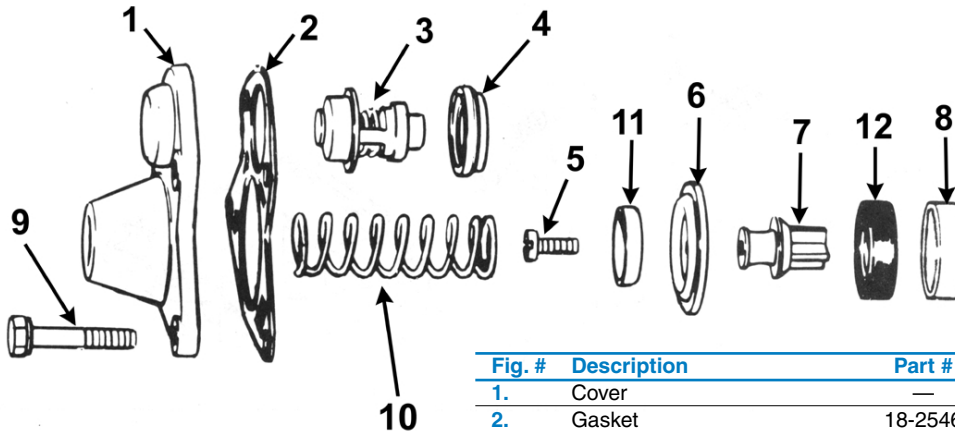

Fig. #	Description	Part #	OEM #	Qty.
1.	Cover	—	321013	1
2.	Gasket	18-2546	321184	1
			434841,	
3.	Thermostat	18-3543	393659	1
4.	Thermostat Gasket	18-0182	310058	1
5.	Stainless Steel Bolt	18-3135	306643	1
6.	Seal	18-3567	321221	1
7.	Valve	18-3563	321027	1
8.	Valve Cup	18-3562	321222	1
9.	Screw	—	306778	4
10.	Spring	18-1243	317245	1
11.	Retainer	18-3565	321220	1
12.	Grommet	18-1219	320880	1

Courtesy of Seloc Publishing

APPLICATION ON NEXT PAGE

JOHNSON/EVINRUDE (OMC/BRP)

Cooling System



OUTBOARD

HP	Years	Thermostat Kit	Thermostat	Valve	Valve Seat	Valve Diaphragm	Valve Retainer	Valve Cup	Valve Spring	Grommet
5	1965-68, 1986	18-3672 ⑤	18-3543	—	—	—	—	—	—	—
5.5	1959-64	18-3672 ⑤	18-3543	—	—	—	—	—	—	—
6	1965-79, 1986	18-3672 ⑤	18-3543	—	—	—	—	—	—	—
7.5	1980-86	18-3672 ⑤	18-3543	—	—	—	—	—	—	—
8	1986	18-3672 ⑤	18-3543	—	—	—	—	—	—	—
9.5	1964-73	18-3672 ⑤	18-3543	—	—	—	—	—	—	—
9.9	1974-86	18-3672 ⑤	18-3543	—	—	—	—	—	—	—
10	1959-63	18-3672 ⑤	18-3543	—	—	—	—	—	—	—
15	1974-86	18-3672 ⑤	18-3543	—	—	—	—	—	—	—
18	1959-73	18-3672 ⑤	18-3543	—	—	—	—	—	—	—
20	1981-94	18-3672 ⑤	18-3543	—	—	—	—	—	—	—
25 ①	1969-94	18-3672 ⑤	18-3543	—	—	—	—	—	—	—
28	1989-94	18-3672 ⑤	18-3543	—	—	—	—	—	—	—
30	1986-94	18-3672 ⑤	18-3543	—	—	—	—	—	—	—
35	1959, 1976-94	18-3672 ⑤	18-3543	—	—	—	—	—	—	—
40	1960-69	18-3672 ⑤	18-3543	—	—	—	—	—	—	—
45	1989-92 ②	18-3672 ⑤	18-3543	—	—	—	—	—	—	—
50	1971-75, 1979, 1981-86	18-3672 ⑤	18-3543	—	—	—	—	—	—	—
55	1976-92 ③	18-3672 ⑤	18-3543	—	—	—	—	—	—	—
60	1969-70	18-3669 ⑤	18-3557	—	—	—	—	—	—	—
60	1980-86	18-3672 ⑤	18-3543	—	—	—	—	—	—	—
60, 60TTL	1993	—	18-3561	—	—	—	—	—	—	—
65	1971-73	18-3669	18-3557	—	—	—	—	—	—	—
65	1993	—	18-3561	—	—	—	—	—	—	—
65C	1984-86	18-3669	18-3557	—	—	—	—	—	—	—
65 Jet	1994-95	18-3673	18-3543	18-3564	—	—	—	—	18-1243	18-2391
70	1974-86	18-3669	18-3557	—	—	—	—	—	—	—
70,70TTL	1993	—	18-3561	—	—	—	—	—	—	—
75	1978-88	18-3669	18-3557	—	—	—	—	—	—	—
80 Jet	1994-95	18-3673	18-3543	18-3564	—	—	—	—	18-1243	18-2391
85	1978-80	18-3673	18-3543	18-3564	—	—	—	—	18-1243	18-2391
85	1993-95	18-3673	18-3543	18-3564	—	—	—	—	18-1243	18-2391
88	1987-95	18-3673	18-3543	18-3564	—	—	—	—	18-1243	18-2391
90 ④	1983-95	18-3673	18-3543	18-3564	—	—	—	—	18-1243	18-2391
90 Jet	1994	18-3673	18-3543	18-3564	—	—	—	—	18-1243	18-2391
100	1979-80	18-3673	18-3543	18-3564	—	—	—	—	18-1243	18-2391
100	1990-95	18-3673	18-3543	18-3564	—	—	—	—	18-1243	18-2391
100 Comm	1984-95	18-3673	18-3543	18-3564	—	—	—	—	—	—
110	1985-89	18-3673	18-3543	18-3564	—	—	—	—	18-1243	18-2391
112	1994-95	18-3673	18-3543	18-3564	—	—	—	—	18-1243	18-2391
115 ④	1978-95	18-3673	18-3543	18-3564	—	—	—	—	18-1243	18-2391
120	1988-91	—	—	—	—	18-1222	—	18-1221	—	—
140	1978-85	18-3673	18-3543	18-3564	—	—	—	—	18-1243	18-2391
140	1988-91	—	—	—	—	18-1222	—	18-1221	—	—
150	1978-91	18-3672 ⑤	18-3543	18-3563	18-1219	18-3567	18-3565	18-3562	18-1243	18-0182
155	1984-91	18-3672 ⑤	18-3543	18-3563	18-1219	18-3567	18-3565	18-3562	18-1243	18-0182
175	1977-91	18-3672 ⑤	18-3543	18-3563	18-1219	18-3567	18-3565	18-3562	18-1243	18-0182
185	1984-85	18-3672 ⑤	18-3543	18-3563	18-1219	18-3567	18-3565	18-3562	18-1243	18-0182
200	1977-83	18-3672 ⑤	18-3543	18-3563	18-1219	18-3567	18-3565	18-3562	18-1243	18-0182
200	1988-93	—	—	—	—	18-1222	18-3565	18-1221	—	—
225	1988-93	—	—	—	—	18-1222	18-3565	18-1221	—	—
235	1978-85	18-3672 ⑤	18-3543	18-3563	18-1219	18-3567	18-3565	18-3562	18-1243	18-0182

① All 1989-91 models except DR & DT

② Commercial

③ Commercial also

④ Except 60 degree models

⑤ For complete Thermostat Kit including gaskets & spring use 18-3674



Piston Rings are available individually

SIERRA PISTON KIT CONTENTS

(SEE APPLICATION CHARTS FOR SPECIFIC APPLICATIONS)

Model / HP	Cyl.	Bore size	Piston	OEM Part #	Piston Ring	OEM Part #	Wrist Pin	OEM Part #	Circlips	OEM Part #
9.9/15	2	2.188 / std.	18-4106	397487	18-3931	386279	N.S.S.	N/A	—	325262
9.9/15	2	2.208 / .020	18-4116	N/A	—	N/A	N.S.S.	N/A	—	325262
9.9/15	2	2.218 / .030	18-4126	396574	18-3933	386280	N.S.S.	N/A	—	325262
9.9/15	2	2.188 / std.	18-4061	387660	18-3931	386279	N.S.S.	N/A	—	325262
9.9/15	2	2.218 / .030	18-4062	387661	18-3933	386280	N.S.S.	N/A	—	325262
25-35	2	3.000 / std.	18-4107	392621	18-3910	396377	18-4281	320954	18-4290	317831
25-35	2	3.020 / .020	18-4117	N/A	18-3911	396378	18-4281	320954	18-4290	317831
25-35	2	3.030 / .030	18-4127	396576	18-3912	396379	18-4281	320954	18-4290	317831
35-60	2 & 3	3.187 / std.	18-4125	391798	18-3913	391170, 434107	18-4282	322188	18-4290	317831
35-60	2 & 3	3.207 / .020	18-4115	N/A	18-3914	N/A	18-4282	322188	18-4290	317831
35-60	2 & 3	3.217 / .030	18-4105	396581	18-3915	391416, 434109	18-4282	322188	18-4290	317831
60-75	3	3.000 / std.	18-4124	387284	18-3910	396377	18-4281	320954	18-4290	317831
60-75	3	3.020 / .020	18-4114	387285	18-3911	396378	18-4281	320954	18-4290	317831
60-75	3	3.030 / .030	18-4104	396583	18-3912	396379	18-4281	320954	18-4290	317831
50-70	3	3.187 / std.	18-4063	394461	18-3913	391170, 434107	18-4282	322188	18-4290	317831
50-70	3	3.217 / .030	18-4064	398483	18-3915	391416, 434109	18-4282	322188	18-4290	317831

SIERRA V-4/V-6 PISTON KIT CONTENTS

(SEE APPLICATION CHARTS FOR SPECIFIC APPLICATIONS)

Model/HP	Cyl.	Bore Size	Piston	OEM Part #	Piston Ring	OEM Part #	Wrist Pin	OEM Part #	Circlips	OEM Part #
85-300	4 & 6	3.500	18-4120	393271, 393924	18-3904	394930	18-4280	327861	18-4290	317831
85-300	4 & 6	3.520	18-4110	—	18-3906	396503, 385662	18-4280	327861	18-4290	317831
85-300	4 & 6	3.530	18-4100	396585, 396588	18-3905	396504	18-4280	327861	18-4290	317831
150-235	4 & 6	3.625	18-4123	392455	18-3907	390509	18-4280	327861	18-4290	317831
150-235	4 & 6	3.645	18-4113	N/A	18-3909	N/A	18-4280	327861	18-4290	317831
150-235	4 & 6	3.655	18-4103	396587	18-3908	390510	18-4280	327861	18-4290	317831

Loopers

120-300	4 & 6	3.685 (port)	18-4065	432072, 432969	18-3975	431870	N.S.S.	—	18-4292	326765
120-300	4 & 6	3.685 (starboard)	18-4066	432073, 432970	18-3975	431870	N.S.S.	—	18-4292	326765
120-300	4 & 6	3.715 (port)	18-4067	432077, 433003	18-3974	431844	N.S.S.	—	18-4292	326765
120-300	4 & 6	3.715 (starboard)	18-4068	432078, 433004	18-3974	431844	N.S.S.	—	18-4292	326765
120-300	4 & 6	3.500 (port)	18-4122	393566	18-3904	394930	18-4280	327861	18-4290	317831
120-300	4 & 6	3.500 (starboard)	18-4121	391481	18-3904	394930	18-4280	327861	18-4290	317831
120-300	4 & 6	3.520 (port)	18-4112	N/A	18-3906	396503, 385662	18-4280	327861	18-4290	317831
120-300	4 & 6	3.520 (starboard)	18-4111	N/A	18-3906	396503, 385662	18-4280	327861	18-4290	317831
120-300	4 & 6	3.530 (port)	18-4102	393612	18-3905	396504	18-4280	327861	18-4290	317831
120-300	4 & 6	3.530 (starboard)	18-4101	391653	18-3905	396504	18-4280	327861	18-4290	317831
185, 200-225	6	3.5995 (port)	standard 18-4190	436860	18-3901	436254	—	—	—	—
185, 200-225	6	3.5995 (starboard)	standard 18-4079	436859	18-3901	436254	—	—	—	—
185, 200-225	6	3.5995 (port)	.020 18-4195	439015	18-3947	439538	—	—	—	—
185, 200-225	6	3.5995 (starboard)	.020 18-4086	439516	18-3947	439538	—	—	—	—
185, 200-225	6	3.5995 (port)	.030 18-4165	439515	18-3949	436251	—	—	—	—
185, 200-225	6	3.5995 (starboard)	.030 18-4087	439517	18-3949	436251	—	—	—	—

APPLICATION CHART ON NEXT PAGE

JOHNSON/EVINRUDE (OMC/BRP)

Internal Engine System



INLINE PISTON & RINGS APPLICATION

HP	YEAR	CYL	STD. BORE	STD PISTON	.020 OS PISTON	.030 OS PISTON	STD RINGS	.020 OS RINGS	.030 OS RINGS
5/6/8	1986-95	2	2.188	18-4069	—	—	18-3972	—	—
9.9/15	1974-80	2	2.188	18-4061	—	18-4062	18-3931	—	18-3933
9.9/15	1981-93	2	2.188	18-4106	18-4116	18-4126	18-3931	—	18-3933
10	1988-90	2	2.188	18-4106	18-4116	18-4126	18-3931	—	18-3933
14	1988-90	2	2.188	18-4106	18-4116	18-4126	18-3931	—	18-3933
15 4-Stroke	1995-UP	2	2.188	18-4106	18-4116	18-4126	18-3931	—	18-3933
18 Jet	1995-98	2	3.000	18-4107	18-4117	18-4127	18-3910	18-3911	18-3912
20	1981-99	2	3.000	18-4107	18-4117	18-4127	18-3910	18-3911	18-3912
25	1977-80	2	3.000	—	—	—	18-3910	18-3911	18-3912
25	1981-96	2	3.000	18-4107	18-4117	18-4127	18-3910	18-3911	18-3912
25	1983-93	2	3.187	18-4125	18-4115	18-4105	18-3913	18-3914	18-3915
28	1986-96	2	3.000	18-4107	18-4117	18-4127	18-3910	18-3911	18-3912
28 Jet	1995-96	2	3.187	18-4125	18-4115	18-4105	18-3913	18-3914	18-3915
30	1984-98	2	3.000	18-4107	18-4117	18-4127	18-3910	18-3911	18-3912
35	1976-80	2	3.000	—	—	—	18-3910	18-3911	18-3912
35	1981-92	2	3.000	18-4107	18-4117	18-4127	18-3910	18-3911	18-3912
35	1986-87	2	3.187	18-4125	18-4115	18-4105	18-3913	18-3914	18-3915
35 Jet	1990-98	2	3.187	18-4125	18-4115	18-4105	18-3913	18-3914	18-3915
40	1975-83	2	3.187	—	—	—	18-3913	18-3914	18-3915
40	1984-98	2	3.187	18-4125	18-4115	18-4105	18-3913	18-3914	18-3915
40 Comm.	1981-97	2	3.187	—	—	—	18-3913	18-3914	18-3915
45 Comm.	1985-92	2	3.187	18-4125	18-4115	18-4105	18-3913	18-3914	18-3915
45SS	1987-90	2	3.187	18-4125	18-4115	18-4105	18-3913	18-3914	18-3915
48	1987-97	2	3.187	18-4125	18-4115	18-4105	18-3913	18-3914	18-3915
50	1981-95	2	3.187	18-4125	18-4115	18-4105	18-3913	18-3914	18-3915
50	1995-98	3	3.187	18-4063	—	18-4064	18-3913	18-3914	18-3915
55	1976-79	2	3.187	—	—	—	18-3913	18-3914	18-3915
55 Comm.	1980-95	2	3.187	18-4125	18-4115	18-4105	18-3913	18-3914	18-3915
60	1980-85	2	3.187	18-4125	18-4115	18-4105	18-3913	18-3914	18-3915
60 (49 CID Model)	1986-88	3	3.000	18-4124	18-4114	18-4104	18-3910	18-3911	18-3912
60	1986-98	3	3.187	18-4063	—	18-4064	18-3913	18-3914	18-3915
65, 65 Comm.	1972-73	3	3.000	—	—	—	18-3910	18-3911	18-3912
49 CID Model	1984-86	3	3.000	18-4124	18-4114	18-4104	18-3910	18-3911	18-3912
65	1987-95	3	3.187	18-4063	—	18-4064	18-3913	18-3914	18-3915
65 Jet	1991-95	4	3.500	18-4120	18-4110	18-4100	18-3904	18-3906	18-3905
70	1974-75	3	3.000	—	—	—	18-3910	18-3911	18-3912
70	1976-85	3	3.000	18-4124	18-4114	18-4104	18-3910	18-3911	18-3912
70	1986-94	3	3.187	18-4063	—	18-4064	18-3913	18-3914	18-3915
75	1975	3	3.000	—	—	—	18-3910	18-3911	18-3912
75	1976-88	3	3.000	18-4124	18-4114	18-4104	18-3910	18-3911	18-3912

JOHNSON/EVINRUDE PISTONS (for V-4, V-6 and V-8 Applications)

H.P.	CYL.	YEAR	STD. BORE	STANDARD		.020" O.S		.030" O.S		PISTON RINGS	.020" O.S. RINGS	.030" O.S. RINGS	POWERHEAD BEARING SET
				(PORT)	(STBD)	(PORT)	(STBD)	(PORT)	(STBD)				
65 Jet	4	1991-95	3.500	18-4120	18-4120	18-4110	18-4110	18-4100	18-4100	18-3904	18-3906	18-3905	18-1386
80 Jet	4	1991-96	3.500	18-4120	18-4120	18-4110	18-4110	18-4100	18-4100	18-3904	18-3906	18-3905	—
85	4	1979-80, 1991-95	3.500	18-4120	18-4120	18-4110	18-4110	18-4100	18-4100	18-3904	18-3906	18-3905	18-1386
88	4	1987-95	3.500	18-4120	18-4120	18-4110	18-4110	18-4100	18-4100	18-3904	18-3906	18-3905	18-1386
90	4	1981-98	3.500	18-4120	18-4120	18-4110	18-4110	18-4100	18-4100	18-3904	18-3906	18-3905	18-1386
100 ①	4	1979-97	3.500	18-4120	18-4120	18-4110	18-4110	18-4100	18-4100	18-3904	18-3906	18-3905	18-1386
110	4	1986-90	3.500	18-4120	18-4120	18-4110	18-4110	18-4100	18-4100	18-3904	18-3906	18-3905	18-1386
115	4	1974-77	3.500	18-4120	18-4120	18-4110	18-4110	18-4100	18-4100	18-3904	18-3906	18-3905	—
115	4	1978-98	3.500	18-4120	18-4120	18-4110	18-4110	18-4100	18-4100	18-3904	18-3906	18-3905	18-1386
120	4	1985-87	3.500	18-4122	18-4121	18-4112	18-4111	18-4102	18-4101	18-3904	18-3906	18-3905	—
120	4	1988-94	3.685	18-4065	18-4066	—	—	18-4067	18-4068	18-3975	—	18-3974	—
125 Comm.	4	1992-95	3.685	18-4065	18-4066	—	—	18-4067	18-4068	18-3975	—	18-3974	—
130	4	1995-98	3.685	18-4065	18-4066	—	—	18-4067	18-4068	18-3975	—	18-3974	—
135	4	1973-76	3.500	18-4120	18-4120	18-4110	18-4110	18-4100	18-4100	18-3904	18-3906	18-3905	—
140	4	1977	3.500	18-4120	18-4120	18-4110	18-4110	18-4100	18-4100	18-3904	18-3906	18-3905	—

① Except 1991 60° V Models



JOHNSON/EVINRUDE (OMC/BRP) Internal Engine System

JOHNSON/EVINRUDE PISTONS (for V-4, V-6 and V-8 Applications) (Cont.)													
H.P.	CYL.	YEAR	STD. BORE	STANDARD		.020" O.S.		.030" O.S.		PISTON RINGS	.020" O.S. RINGS	.030" O.S. RINGS	POWERHEAD BEARING SET
				(PORT)	(STBD)	(PORT)	(STBD)	(PORT)	(STBD)				
140	4	1978-84	3.500	18-4120	18-4120	18-4110	18-4110	18-4100	18-4100	18-3904	18-3906	18-3905	18-1386
140	4	1985-87	3.500	18-4122	18-4121	18-4112	18-4111	18-4102	18-4101	18-3904	18-3906	18-3905	—
140	4	1988-94	3.685	18-4065	18-4066	—	—	18-4067	18-4068	18-3975	—	18-3974	—
1600CC	4	1988	3.500	18-4120	18-4120	18-4110	18-4110	18-4100	18-4100	18-3904	18-3906	18-3905	18-1386
150	6	1973-77	3.500	18-4120	18-4120	18-4110	18-4110	18-4100	18-4100	18-3904	18-3906	18-3905	—
150	6	1978-91	3.500	18-4120	18-4120	18-4110	18-4110	18-4100	18-4100	18-3904	18-3906	18-3905	—
155 Comm.	6	1984-92	3.500	18-4120	18-4120	18-4110	18-4110	18-4100	18-4100	18-3904	18-3906	18-3905	—
175	6	1977-83	3.500	18-4120	18-4120	18-4110	18-4110	18-4100	18-4100	18-3904	18-3906	18-3905	—
175	6	1986-91	3.625	18-4123	18-4123	18-4113	18-4113	18-4103	18-4103	18-3907	18-3909	18-3908	—
185	6	1984-85	3.500	18-4120	18-4120	18-4110	18-4110	18-4100	18-4100	18-3904	18-3906	18-3905	—
185	6	1990-93	—	—	—	—	—	—	—	—	—	—	18-1389
185 Looper	6	1993-94	3.5995	18-4190	18-4079	18-4195	18-4086	18-4165	18-4087	—	—	—	—
200	6	1976-83	3.500	18-4120	18-4120	18-4110	18-4110	18-4100	18-4100	18-3904	18-3906	18-3905	18-1389
200	6	1985-87	3.500	18-4122	18-4121	18-4112	18-4111	18-4102	18-4101	18-3904	18-3906	18-3905	—
200 ①	6	1988-93	3.685	18-4065	18-4066	—	—	18-4067	18-4068	18-3975	—	18-3974	18-1389
200-225 Looper	6	1993-01	3.5995	18-4190	18-4079	18-4195	18-4086	18-4165	18-4087	—	—	—	—
225	6	1985-87	3.500	18-4122	18-4121	18-4112	18-4111	18-4102	18-4101	18-3904	18-3906	18-3905	18-1389
225	6	1988-93	3.685	18-4065	18-4066	—	—	18-4067	18-4068	18-3975	—	18-3974	18-1389
235	6	1980-85	3.625	18-4123	18-4123	18-4113	18-4113	18-4103	18-4103	18-3907	18-3909	18-3908	—
250/300	6	1990-93	3.685	18-4065	18-4066	—	—	18-4067	18-4068	18-3975	—	18-3974	—
2500CC	6	1988	3.500	18-4120	18-4120	18-4110	18-4110	18-4100	18-4100	18-3904	18-3906	18-3905	—
250	6	1988-92	3.685	18-4065	18-4066	—	—	18-4067	18-4068	18-3975	—	18-3974	—
275	8	1988-92	3.685	18-4065	18-4066	—	—	18-4067	18-4068	18-3975	—	18-3974	—
275	8	1985-87	3.500	18-4122	18-4121	18-4112	18-4111	18-4102	18-4101	18-3904	18-3906	18-3905	—
300	8	1988-92	3.685	18-4065	18-4066	—	—	18-4067	18-4068	18-3975	—	18-3974	—
300/3.6L	8	1985-87	3.500	18-4122	18-4121	18-4112	18-4111	18-4102	18-4101	18-3904	18-3906	18-3905	—

① Except 1991 60° V Models

60° Eagle Series

HP	Cyl.	Bore Size	Piston	OE No.	Piston Ring	OE No.	Wrist Pin	OE No.	Circlips	OE No.
90-175	4 & 6	3.600 (port)	18-4055	436242	18-4088	436353	N.S.S.	N.S.S.	N.S.S.	N.S.S.
90-175	4 & 6	3.600(starboard)	18-4056	436243	18-4088	436353	N.S.S.	N.S.S.	N.S.S.	N.S.S.
90-175	4 & 6	3.620 (port)	18-4057	N/A	18-4089	N/A	N.S.S.	N.S.S.	N.S.S.	N.S.S.
90-175	4 & 6	3.620 (starboard)	18-4058	N/A	18-4089	N/A	N.S.S.	N.S.S.	N.S.S.	N.S.S.
90-175	4 & 6	3.630 (port)	18-4059	439519	18-4090	436354	N.S.S.	N.S.S.	N.S.S.	N.S.S.

OMC V-4/V-6 60° Eagle Series Pistons

H.P.	YEAR	CYL.	STD. BORE	STANDARD		.020" O.S.		.030" O.S.		STD. RINGS	.020" O.S. RINGS	.030" O.S. RINGS
				(PORT)	(STBD)	(PORT)	(STBD)	(PORT)	(STBD)			
90-175	1991-2000	4 & 6	3.600	18-4055	18-4056	18-4057	18-4058	18-4059	18-4060	18-4088	18-4089	18-4090

OMC SEA DRIVE PISTONS

H.P.	YEAR	CYL.	STD. BORE	STANDARD		.020" O.S.		.030" O.S.		STD. RINGS	.020" O.S. RINGS	.030" O.S. RINGS
				(PORT)	(STBD)	(PORT)	(STBD)	(PORT)	(STBD)			
1.6L	1983-89	4	3.500	18-4120	18-4120	18-4110	18-4110	18-4100	18-4100	18-3904	18-3906	18-3905
1.8L	1987	4	3.500	18-4122	18-4121	18-4112	18-4111	18-4102	18-4101	18-3904	18-3906	18-3905
2.5L	1982, 1984-85	6	3.500	18-4120	18-4120	18-4110	18-4110	18-4100	18-4100	18-3904	18-3906	18-3905
2.6L	1982-86	6	3.625	18-4123	18-4123	18-4113	18-4113	18-4103	18-4103	18-3907	18-3909	18-3908
2.7L	1987	6	3.500	18-4122	18-4121	18-4112	18-4111	18-4102	18-4101	18-3904	18-3906	18-3905
3.6L	1987	8	3.500	18-4122	18-4121	18-4112	18-4111	18-4102	18-4101	18-3904	18-3909	18-3905

OUTBOARD

JOHNSON/EVINRUDE (OMC/BRP)

Internal Engine System



ORIGINAL EQUIPMENT MANUFACTURER RECOMMENDS THE REPLACEMENT OF ROD BOLTS WITH EVERY POWER HEAD REBUILD.



18-4197
CRANKSHAFT
3 Cylinder Looper
Replaces: 334665

YEAR	HP
1989-92	60
1989-92	65 Comm
1989-95	70



ROD BOLTS

Part #	OE#	Application
18-4075	308186	For V-4 & V-6 Crossflow engines
18-4075-9 ①②	308186	For V-4 & V-6 Crossflow engines
18-4076	330081	For V-4 Looper engines



18-1752
CONNECTING ROD
Replaces: 394462

For: 40HP (1999-01), 50HP (1995-98), 60HP (1989-01), 70HP (1986-01)



18-1753
CONNECTING ROD
Replaces: 395861

For: 30HP (1999-01), 40 HP (1985-02), 45HP (1986-87, 1990-97), 48HP (1987-96), 50HP (1985-02), 55HP (1985-93, 1999-01), 60 HP (1985)



18-4148-1
CONNECTING ROD

Replaces: 394488, 5004705
For V-4 Looper engines and some V-6 applications



SLEEVE

Part No.	I.D.	O.D.	Wall	Length	Description
18-4712	3.1875	3.453	0.125	5.556	Replacement straight sleeve with ports cut in



18-1352
CENTER MAIN BEARING

Replaces: 378252



18-1353
CENTER MAIN BEARING

Replaces: 387041



18-1359
ROD BEARING

Replaces: 395401



18-1360
ROD BEARING

Replaces: 396041

APPLICATION BEGINS ON PAGE 204

 <p>18-1361 ROD CRANK END BEARING Replaces: 387787</p>	 <p>18-1362 SPLIT SLEEVE BEARING Replaces: 310433</p>	 <p>18-1372 UPPER MAIN BEARING Replaces: 390900</p>	 <p>18-1373 UPPER MAIN BEARING Replaces: 398529</p>	 <p>18-1296 WRIST PIN BEARING Replaces: 386014, 3855270 For: 9.9-15 HP</p>																				
 <p>18-1374 WRIST PIN BEARING Replaces: 395627</p>	 <p>18-1375 WRIST PIN BEARING Replaces: 378251</p>	 <p>18-1376 WRIST PIN BEARING Replaces: 434844</p>	 <p>18-1377 CENTER MAIN BEARING Replaces: 320499</p>																					
 <p>18-1378 ROD BEARING Replaces: 388344</p>	 <p>18-4040 NEEDLE BEARINGS (18 Needles) Replaces: 387142, 387139 (Crank End) (Must re-use cage)</p>	 <p>POWERHEAD BEARING KITS</p> <table border="1"> <thead> <tr> <th>Part #</th> <th>Part #</th> </tr> </thead> <tbody> <tr> <td>18-1382</td> <td>18-1386</td> </tr> </tbody> </table>		Part #	Part #	18-1382	18-1386																	
Part #	Part #																							
18-1382	18-1386																							
<table border="1"> <thead> <tr> <th>Part #</th> <th>Replaces:</th> <th>Description</th> </tr> </thead> <tbody> <tr> <td>18-1391</td> <td>330854</td> <td>Lower Crankshaft Bearing</td> </tr> <tr> <td>18-1392</td> <td>386481</td> <td>Upper Crankshaft Bearing</td> </tr> <tr> <td>18-1394</td> <td>389613</td> <td>Center Main Bearing</td> </tr> <tr> <td>18-1393</td> <td>393896</td> <td>Upper Crankshaft Bearing</td> </tr> <tr> <td>18-1395</td> <td>385503</td> <td>Lower Crankshaft Bearing</td> </tr> <tr> <td>18-1396</td> <td>390641</td> <td>Lower Crankshaft Bearing</td> </tr> </tbody> </table>		Part #	Replaces:	Description	18-1391	330854	Lower Crankshaft Bearing	18-1392	386481	Upper Crankshaft Bearing	18-1394	389613	Center Main Bearing	18-1393	393896	Upper Crankshaft Bearing	18-1395	385503	Lower Crankshaft Bearing	18-1396	390641	Lower Crankshaft Bearing	 <p>POWERHEAD BEARINGS</p>	
Part #	Replaces:	Description																						
18-1391	330854	Lower Crankshaft Bearing																						
18-1392	386481	Upper Crankshaft Bearing																						
18-1394	389613	Center Main Bearing																						
18-1393	393896	Upper Crankshaft Bearing																						
18-1395	385503	Lower Crankshaft Bearing																						
18-1396	390641	Lower Crankshaft Bearing																						

JOHNSON/EVINRUDE (OMC/BRP)

Internal Engine System



H.P.	Year	Sleeve	Connecting Rod	Rod Bolt	Wrist Pin Brg.	Rod Brg. Complete	Rod Brgs. Only	Center Main Brg.	Split bearing [sleeve]	Upper Crank Brg.	Lower Crank Brg.	Powerhead Brg. Kit
2 CYLINDER												
9.9	1974-83	-	-	-	-	18-1359	-	18-1359	-	-	-	-
9.9	1974-80	-	-	-	-	18-1359	-	18-1359	-	-	-	-
9.9	1981-83	-	-	-	-	18-1359	-	18-1359	-	-	-	-
9.9	1986-92	-	-	-	-	18-1359	-	-	-	-	-	-
9.9	1984-97	-	-	-	-	18-1359	-	-	-	-	-	-
9.9	1998	-	-	-	-	18-1359	-	-	-	-	-	-
14 Comm	1988-89	-	-	-	-	18-1359	-	-	-	-	-	-
15	1974-83	-	-	-	-	18-1359	-	18-1359	-	-	-	-
15	1984-97	-	-	-	-	18-1359	-	-	-	-	-	-
15 Comm	1994	-	-	-	18-1296	18-1359	-	-	-	-	-	-
18	1960-68	-	-	-	-	-	18-4040	-	-	-	-	-
18	1970-73	-	-	-	18-1375	-	18-4040	-	-	-	-	-
18 Jet	1996-97	-	-	-	18-1374	18-1378	-	18-1394	-	18-1393	18-1391	-
20	1981-84	-	-	-	18-1374	18-1378	18-4040	18-1394	-	-	18-1391	-
20	1985-97	-	-	-	18-1374	18-1378	-	18-1394	-	18-1393	18-1391	-
25	1970-76	-	-	-	18-1375	-	18-4040	-	-	-	-	-
25	1977	-	-	-	18-1375	18-1378	18-4040	-	-	18-1392	18-1391	-
25	1978-80	-	-	18-4075	18-1375	18-1378	18-4040	18-1394	-	18-1392	18-1391	-
25	1981-84	-	-	-	18-1374	18-1378	18-4040	18-1394	-	18-1391	18-1391	-
25 ①	1985-97	-	-	-	-	-	-	18-1394	-	18-1393	18-1391	-
25	1985-97	-	-	18-4075	18-1374	18-1378	-	-	-	-	-	-
25 Comm	1982-84	-	-	-	18-1374	18-1378	18-4040	18-1394	-	18-1392	18-1391	-
25 Comm	1985-97	-	-	-	18-1374	18-1378	-	18-1394	-	18-1393	18-1391	-
28	1987-97	-	-	-	18-1374	18-1378	-	18-1394	-	18-1393	18-1391	-
30	1981-93	-	-	18-4075	18-1374	18-1378	18-4040	-	-	-	-	-
30	1984-1992	-	-	18-4075	-	18-1378	18-4040	18-1394	-	-	-	-
30	1985-97	-	-	-	18-1374	18-1378	18-4040	18-1394	-	18-1393	18-1391	-
30	1984	-	-	-	-	18-1378	18-4040	18-1394	-	18-1392	18-1391	-
33	1965-69	-	-	-	-	18-1378	18-4040	-	-	-	-	-
33	1970	-	-	-	18-1375	18-1378	18-4040	-	-	-	-	-
35	1976-80	-	-	-	18-1375	18-1378	18-4040	-	-	18-1392	18-1391	-
35	1981-84	-	-	18-4075	18-1374	-	18-4040	18-1394	-	18-1392	18-1391	-
35	1985-97	-	-	-	18-1374	18-1378	-	18-1394	-	18-1393	18-1391	-
35	1976-1993	-	-	18-4075	18-1374	18-1378	-	-	-	-	-	-
35	1977	-	-	18-4075	-	-	-	-	-	-	-	-
35	1978-1980	-	-	18-4075	18-1375	18-1378	18-4040	18-1394	-	18-1392	18-1391	-
35	1981-1993	-	-	18-4075	18-1374	18-1378	-	18-1394	18-1362	18-1393	18-1391	-
40	1984-92	18-4712	-	18-4075	18-1374	18-1378	-	18-1352	18-1362	18-1373	18-1391	-
40	1961-70	-	-	-	-	-	18-4040	-	-	-	-	-
40	1971-73	-	-	-	18-1375	18-1378	18-4040	-	-	-	-	-
40	1974-76	-	-	-	18-1375	18-1378	18-4040	18-1352	18-1362	-	18-1154	-
40	1984-86	-	-	-	18-1374	18-1378	-	18-1352	18-1362	18-1372	18-1154	-
40	1987-97	-	-	-	18-1374	18-1378	-	18-1352	18-1362	18-1373	18-1154	-
40	1983	-	-	18-4075	18-1375	-	-	18-1352	18-1362	-	18-1154	-
40 Comm	1982-83	-	-	-	18-1375	18-1378	-	18-1352	18-1362	-	-	-
40 Comm	1984-85	-	-	-	18-1375	18-1378	-	18-1352	18-1362	18-1372	-	-
40 Comm	1989-90	-	-	-	18-1375	18-1378	-	18-1352	18-1362	18-1373	-	-
40 Comm	1994	-	-	-	18-1374	18-1378	-	18-1352	18-1362	18-1373	-	-
40 Comm	1995-97	-	-	-	18-1374	-	-	18-1352	18-1362	18-1373	-	-
45 Comm	1985-86	-	-	-	18-1374	18-1378	-	18-1352	18-1362	18-1372	-	-
45 Comm	1987-94	-	-	-	18-1374	18-1378	-	18-1352	18-1362	18-1372	-	-
45 Comm	1995-97	-	-	-	18-1374	-	-	18-1352	18-1362	18-1373	-	-
45 Comm	1987	-	-	-	18-1374	18-1378	-	18-1352	18-1362	18-1373	18-1154	-
45ss	1987-90	-	-	-	18-1374	18-1378	-	18-1352	18-1362	18-1372	-	-
48	1987	18-4712	-	-	18-1374	18-1378	-	18-1352	18-1362	18-1372	-	-
48	1987-92	18-4712	-	18-4075	18-1374	18-1378	-	18-1352	18-1362	-	-	-
48	1988-96	-	-	-	18-1374	18-1378	-	18-1352	18-1362	18-1373	-	-
50	1979-83	18-4712	-	18-4075	18-1374	18-1378	18-4040	18-1352	18-1362	18-1372	-	-
50	1979-86	-	-	-	18-1374	18-1378	-	18-1352	18-1362	18-1372	-	-
50	1981-93	18-4712	-	18-4075	18-1374	18-1378	-	18-1352	18-1362	18-1373	-	-
50②	1987-97	-	-	-	18-1374	18-1378	-	18-1352	18-1362	18-1373	-	-

① Except "D" Models
 ② Two Cylinder Models
 ③ Three Cylinder Models

④ 90 Degree Models
 ⑤ 60 Degree Models
 ⑥ V-4, V-6 & V-8 Model engines do not include upper bearings in kits

APPLICATION CONTINUED ON NEXT PAGE



JOHNSON/EVINRUDE (OMC/BRP) Internal Engine System

H.P.	Year	Sleeve	Connecting Rod	Rod Bolt	Wrist Pin Brg.	Rod Brg. Complete	Rod Brgs. Only	Center Main Brg.	Split bearing [sleeve]	Upper Crank Brg.	Lower Crank Brg.	Powerhead Brg. Kit
50 ^③	1995-97	-	-	-	18-1374	18-1378	-	18-1352	18-1362	18-1373	-	-
55	1968-69	-	-	-	18-1375	18-1378	18-4040	18-1352	18-1362	-	-	-
55	1976-81	-	-	-	18-1374	18-1378	18-4040	18-1352	18-1362	18-1372	-	-
55 Comm	1982	-	-	-	18-1374	18-1378	18-4040	18-1352	18-1362	18-1372	-	-
55 Comm	1983-86	-	-	-	18-1374	18-1378	-	18-1352	18-1362	18-1372	-	-
55 Comm	1987-94	-	-	-	18-1374	18-1378	-	18-1352	18-1362	18-1373	-	-
55 Comm	1995-97	-	-	-	18-1374	18-1378	-	18-1352	18-1362	18-1373	-	-
55	1978-93	18-4712	-	18-4075	-	-	-	-	-	-	-	-
60	1980-85	18-4712	-	18-4075	18-1374	18-1378	-	18-1352	18-1362	18-1372	-	-
60	1964-67,1970-71	-	-	-	18-1375	18-1378	18-4040	18-1352	18-1362	-	-	-
60	86-90	-	-	-	18-1374	18-1378	-	18-1352	18-1362	18-1372	-	-
60	1991-93	-	-	-	18-1374	18-1378	-	18-1352	18-1362	18-1373	-	-
60	1994-97	-	-	-	18-1374	-	-	18-1352	18-1362	18-1373	-	-
SST-60	1989-90	-	-	-	18-1374	18-1378	-	18-1352	18-1362	18-1372	-	18-1382
3 CYLINDER												
60	1985	-	-	18-4075	18-1374	18-1378	18-4040	18-1352	18-1362	18-1372	-	-
60	1986-90	-	-	-	18-1374	18-1378	18-4040	18-1352	18-1362	18-1372	-	18-1382
60	1986-88	-	-	18-4075	18-1374	18-1378	18-4040	18-1352	18-1362	18-1372	-	-
60	1989-92	-	-	18-4075	18-1374	18-1378	18-4040	18-1352	18-1362	-	-	-
65	1968	-	-	-	18-1375	18-1378	18-4040	18-1352	18-1362	-	-	-
65	1972-73	-	-	-	18-1375	18-1378	18-4040	18-1352	18-1362	18-1372	-	-
65 Comm	1984	-	-	-	18-1374	18-1378	18-4040	18-1352	18-1362	18-1372	-	-
65 Comm	1985-90	-	-	-	18-1374	18-1378	18-4040	18-1352	18-1362	18-1372	-	18-1382
65 Comm	1991-93	-	-	-	18-1374	18-1378	18-4040	18-1352	18-1362	18-1373	-	-
65 Comm.	1994-97	-	-	-	18-1374	18-1378	18-4040	18-1352	18-1362	18-1373	-	-
65	1984-86	-	-	18-4075	18-1374	18-1378	18-4040	18-1352	18-1362	18-1372	18-1154	18-1382
70	1976-85	-	-	18-4075	18-1374	18-1378	18-4040	18-1352	18-1362	18-1372	18-1154	18-1382
70	1974-75	-	-	-	18-1375	18-1378	18-4040	18-1352	18-1362	18-1372	-	-
70	1976-90	-	-	-	18-1374	18-1378	18-4040	18-1352	18-1362	18-1372	18-1154	18-1382
70	1976-84	-	-	18-4075	18-1374	18-1378	18-4040	18-1352	18-1362	18-1372	18-1154	18-1382
70	1985-90	-	-	-	18-1374	18-1378	18-4040	18-1352	18-1362	18-1372	18-1154	18-1382
70	1991-93	-	-	-	18-1374	18-1378	18-4040	18-1352	18-1362	18-1373	-	-
70	1994-97	-	-	-	18-1374	-	-	18-1352	18-1362	18-1373	-	-
75	1960-65	-	-	-	18-1375	18-1378	18-4040	18-1352	18-1362	-	-	-
75	1975	-	-	-	18-1375	18-1378	18-4040	18-1352	18-1362	18-1372	18-1154	-
75	1976-84	-	-	18-4075	18-1374	18-1378	18-4040	18-1352	18-1362	18-1372	18-1154	18-1382
75	1982-88	-	-	18-4075	18-1374	18-1378	18-4040	18-1352	18-1362	18-1372	18-1154	18-1382
75	1985-88	-	-	-	18-1374	18-1378	18-4040	18-1352	18-1362	18-1372	18-1154	18-1382
75 ^⑥	1976-88	-	-	18-4075	18-1374	18-1378	18-4040	18-1352	18-1362	18-1372	18-1154	18-1382
V-4 CROSSFLOW												
65JET	1992-95	-	-	18-4075	18-1374	18-1361	18-4040	18-1353	18-1377	-	18-1395	18-1386
80	1966-67	-	-	-	18-1375	18-1378	18-4040	18-1352	18-1362	-	-	-
80JET	1993-97	-	-	18-4075	18-1374	18-1361	18-4040	18-1353	18-1377	-	18-1395	18-1386
80JET	1992-97	-	-	-	18-1374	18-1361	18-4040	18-1353	18-1377	-	18-1395	18-1386
85	1968-72	-	-	-	18-1375	18-1378	18-4040	18-1352	18-1362	-	18-1154	-
85	1973	-	-	-	18-1374	18-1378	18-4040	18-1352	18-1362	-	18-1395	-
85	1974-78	-	-	-	18-1374	18-1361	18-4040	18-1352	18-1362	-	18-1395	-
85 ^⑥	1979-80	-	-	18-4075	18-1374	18-1361	18-4040	18-1353	18-1377	-	18-1395	18-1386
85 ^⑥	1991-95	-	-	-	18-1374	18-1361	18-4040	18-1353	18-1377	-	18-1395	18-1386
85	1979-80,1992	-	-	18-4075	18-1374	18-1361	18-4040	18-1353	18-1377	-	18-1395	18-1386
85TTL	1992-95	-	-	18-4075	18-1374	18-1361	18-4040	18-1353	18-1377	-	18-1395	18-1386
88	1987-91	-	-	18-4075	18-1374	18-1361	18-4040	18-1353	18-1377	-	18-1395	18-1386
88 ^⑥	1987-96	-	-	18-4075	18-1374	18-1361	18-4040	18-1353	18-1377	-	18-1395	18-1386
88	1987-92	-	-	18-4075	18-1374	18-1361	18-4040	18-1353	18-1377	-	18-1395	18-1386
88	1993	-	-	18-4075	18-1374	18-1361	18-4040	18-1353	18-1377	-	18-1395	18-1386
88	1992-96	-	-	18-4075	18-1374	18-1361	18-4040	18-1353	18-1377	-	18-1395	18-1386
90	1981-86	-	-	18-4075	18-1374	18-1361	18-4040	18-1353	18-1377	-	18-1395	18-1386
90	1986-91	-	-	18-4075	18-1374	18-1361	18-4040	18-1353	18-1377	-	18-1395	18-1386
90	1992-94	-	-	18-4075	18-1374	18-1361	18-4040	18-1353	18-1377	-	18-1395	18-1386
90 ^⑥ ④	1981-97	-	-	18-4075	18-1374	18-1361	18-4040	18-1353	18-1377	-	18-1395	18-1386
90 ^④	1981-97	-	-	18-4075	18-1374	18-1361	18-4040	18-1353	18-1377	-	18-1395	18-1386
90 ^⑤	1995-97	-	-	18-4075	18-1374	18-1361	18-4040	18-1353	18-1377	-	18-1395	18-1386
① Except "D" Models				④ 90 Degree Models								
② Two Cylinder Models				⑤ 60 Degree Models								
③ Three Cylinder Models				⑥ V-4, V-6 & V-8 Model engines do not include upper bearings in kits								

OUTBOARD

APPLICATION CONTINUED ON NEXT PAGE

JOHNSON/EVINRUDE (OMC/BRP)

Internal Engine System









OUTBOARD

H.P.	Year	Sleeve	Connecting Rod	Rod Bolt	Wrist Pin Brg.	Rod Brg. Complete	Rod Brgs. Only	Center Main Brg.	Split bearing [sleeve]	Upper Crank Brg.	Lower Crank Brg.	Powerhead Brg. Kit
90JET ⑥	1994-95	-	-	18-4075	18-1374	18-1361	18-4040	18-1353	18-1377	-	18-1395	18-1386
90	1981-92	-	-	18-4075	18-1374	18-1361	18-4040	18-1353	18-1377	-	18-1395	18-1386
90	1993	-	-	18-4075	18-1374	18-1361	18-4040	18-1353	18-1377	-	18-1395	18-1386
100	1966-68	-	-	-	18-1375	18-1378	18-4040	18-1352	18-1362	-	18-1154	-
100	1971-72	-	-	-	18-1375	18-1378	18-4040	18-1352	18-1362	-	18-1154	-
100 ⑥	1979-80	-	-	18-4075	18-1374	18-1361	18-4040	18-1353	18-1377	-	18-1395	18-1386
100	1984-85	-	-	18-4075	18-1374	18-1361	18-4040	18-1353	18-1377	-	18-1395	18-1386
100	1986-91	-	-	18-4075	18-1374	18-1361	18-4040	18-1353	18-1377	-	18-1395	18-1386
100 ⑥	1990-94	-	-	18-4075	18-1374	18-1361	18-4040	18-1353	18-1377	-	18-1395	18-1386
100 Comm ⑥	1984-97	-	-	18-4075	18-1374	18-1361	18-4040	18-1353	18-1377	-	18-1395	18-1386
100	1979-81, 1992	-	-	18-4075	18-1374	18-1361	18-4040	18-1353	18-1377	-	18-1395	18-1386
100	1992-97	-	-	18-4075	18-1374	18-1361	18-4040	18-1353	18-1377	-	18-1395	18-1386
100	1993	-	-	18-4075	18-1374	18-1361	18-4040	18-1353	18-1377	-	18-1395	18-1386
100 Comm	1984-87, 1989-92	-	-	18-4075	18-1374	18-1361	18-4040	18-1353	18-1377	-	18-1395	18-1386
100 Comm.	1993	-	-	18-4075	18-1374	18-1361	18-4040	18-1353	18-1377	-	18-1395	18-1386
110 ⑥	1986-89	-	-	18-4075	18-1374	18-1361	18-4040	18-1353	18-1377	-	18-1395	18-1386
112 ⑥	1994-96	-	-	-	18-1374	18-1361	18-4040	18-1353	18-1377	-	18-1395	18-1386
115	1969-70	-	-	-	18-1375	18-1378	18-4040	18-1352	18-1362	-	18-1154	-
115	1973	-	-	18-4075	18-1374	18-1378	18-4040	18-1352	18-1362	-	18-1395	-
115	1974-78	-	-	18-4075	18-1374	18-1361	18-4040	18-1352	18-1362	-	18-1395	-
115 ④	1990-97	-	-	-	18-1374	18-1361	18-4040	18-1353	18-1377	-	18-1395	18-1386
115 ⑥	1979-85	-	-	18-4075	18-1374	18-1361	18-4040	18-1353	18-1377	-	18-1395	18-1386
115	1991-92	-	-	18-4075	18-1374	18-1361	18-4040	18-1353	18-1377	-	18-1395	18-1386
115	1990-91	-	-	18-4075	18-1374	18-1361	18-4040	18-1353	18-1377	-	18-1395	18-1386
115	1993	-	-	18-4075	18-1374	18-1361	18-4040	18-1353	18-1377	-	18-1395	18-1386
115	1992-94	-	-	18-4075	18-1374	18-1361	18-4040	18-1353	18-1377	-	18-1395	18-1386
115 ④	1990-97	-	-	-	18-1374	18-1361	18-4040	18-1353	18-1377	-	-	-
115 ⑤	1995-97	-	-	-	-	18-1361	18-4040	18-1353	18-1377	-	-	-
115JET ⑥	1994-97	-	-	-	18-1374	18-1361	18-4040	18-1353	18-1377	-	18-1395	18-1386
115C	1984	-	-	18-4075	18-1374	18-1361	18-4040	18-1353	18-1377	-	18-1395	18-1386
120 ⑥	1985-94	-	-	-	18-1376	18-1360	-	18-1353	18-1377	-	18-1396	-
125	1971-72	-	-	-	18-1375	18-1378	18-4040	18-1352	18-1362	-	-	-
125 Comm ⑥	1989-95	-	-	-	18-1376	18-1360	-	18-1353	18-1377	-	18-1396	-
125Esx ⑥	1991-94	-	-	-	18-1376	18-1360	-	18-1353	18-1377	-	18-1396	-
130 ⑥	1994-97	-	-	-	18-1376	18-1360	-	18-1353	18-1377	-	18-1396	-
135	1973	-	-	-	18-1374	18-1378	18-4040	18-1352	18-1362	-	18-1395	-
135	1974-76	-	-	18-4075	18-1374	18-1361	18-4040	18-1352	18-1362	-	18-1395	-
140	1977-78	-	-	18-4075	18-1374	18-1361	18-4040	18-1352	18-1362	-	18-1395	-
140	1979	-	-	18-4075	-	-	-	-	-	-	-	-
140 ⑥	1979-84	-	-	-	18-1374	18-1361	18-4040	18-1353	18-1377	-	18-1395	18-1386
140 ⑥	1985-94	-	-	-	18-1376	18-1360	-	18-1353	18-1377	-	18-1396	-
140	1977-84	-	-	18-4075	18-1374	18-1361	18-4040	18-1353	18-1377	-	18-1395	18-1386
1600CC	1988	-	-	18-4075	-	-	-	-	-	-	-	-
1.6L	-	-	-	18-4075	-	-	-	-	-	-	-	-
V-6 CROSSFLOW												
150 ⑥	1978-91	-	-	-	18-1374	18-1361	18-4040	18-1353	18-1377	-	18-1395	-
150 ⑤	1991-97	-	-	-	-	18-1361	18-4040	18-1353	-	-	-	-
150 Comm ⑤	1993-95	-	-	-	-	18-1361	18-4040	18-1353	-	-	-	-
150	1978-85	-	-	18-4075	18-1374	18-1361	18-4040	18-1353	18-1377	-	18-1395	-
150	1978-88	-	-	18-4075	18-1374	18-1361	18-4040	18-1353	18-1377	-	18-1395	-
150	1986-91	-	-	18-4075	18-1374	18-1361	18-4040	18-1353	18-1377	-	-	-
150	1989-91	-	-	18-4075	18-1374	18-1361	18-4040	18-1353	18-1377	-	-	-
155 Comm	1984-85	-	-	18-4075	18-1374	18-1361	18-4040	18-1353	18-1377	-	18-1395	-
155 Comm ⑥	1984-92	-	-	-	18-1374	18-1361	18-4040	18-1353	18-1377	-	18-1395	-
155 Comm	1986-91	-	-	18-4075	-	-	-	-	-	-	-	-
175 ⑥	1977-91	-	-	-	18-1374	18-1361	18-4040	18-1353	18-1377	-	18-1395	-
175 ⑤	1991-97	-	-	-	-	18-1361	18-4040	18-1353	-	-	-	-
175	1977-83	-	-	18-4075	18-1374	18-1361	18-4040	18-1353	18-1377	-	-	-
175	1986-90	-	-	18-4075	18-1374	18-1361	18-4040	18-1353	18-1377	-	-	-
175	1977-83, 1985	-	-	18-4075	18-1374	18-1361	18-4040	18-1353	18-1377	-	-	-
185 ⑥	1984-85	-	-	18-4075	18-1374	18-1361	18-4040	18-1353	18-1377	-	18-1395	-
185	1990	-	18-4148-1	18-4076	-	-	-	-	-	-	-	-
① Except "D" Models				④ 90 Degree Models								
② Two Cylinder Models				⑤ 60 Degree Models								
③ Three Cylinder Models				⑥ V-4, V-6 & V-8 Model engines do not include upper bearings in kits								

APPLICATION CONTINUED ON NEXT PAGE

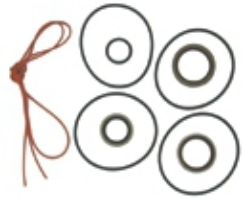
H.P.	Year	Sleeve	Connecting Rod	Rod Bolt	Wrist Pin Brg.	Rod Brg. Complete	Rod Brgs. Only	Center Main Brg.	Split bearing [sleeve]	Upper Crank Brg.	Lower Crank Brg.	Powerhead Brg. Kit
185 ⑥	1990-94	-	-	-	18-1376	18-1360	-	18-1353	18-1377	-	18-1396	18-1389
185	1990-93	-	18-4148-1	18-4076	-	-	-	-	-	-	-	-
185	1992-94	-	18-4148-1	18-4076	-	-	-	-	-	-	-	-
200 ⑥	1976-83	-	-	18-4075	18-1374	18-1361	18-4040	18-1353	18-1377	-	18-1395	18-1389
200	1986-97	-	-	-	18-1376	18-1360	-	18-1353	18-1377	-	18-1396	-
200 Comm	1990	-	18-4148-1	18-4076	-	-	-	-	-	-	18-1396	-
200 Comm	1990-94	-	-	-	18-1376	18-1360	-	18-1353	18-1377	-	-	-
200	1976-83	-	-	18-4075	18-1374	18-1361	18-4040	18-1353	18-1377	-	18-1395	-
200C	1990	-	-	18-4076	18-1376	18-1360	-	18-1353	18-1377	-	18-1396	-
200	1986-91	-	-	18-4076	-	-	-	-	-	-	-	-
200	1986-93	-	-	18-4076	-	-	-	-	-	-	-	-
225 ⑥	1986-97	-	-	-	18-1376	18-1360	-	18-1353	18-1377	-	18-1396	18-1389
235 ⑥	1978-85	-	-	18-4075	18-1374	18-1361	18-4040	18-1353	18-1377	-	18-1395	-
235	1978-79	-	-	18-4075	18-1374	18-1361	18-4040	18-1353	18-1377	-	-	-
235	1980-85	18-4718	-	18-4075	18-1374	18-1361	18-4040	18-1353	18-1377	-	-	-
250	1991-95	-	-	-	18-1376	18-1360	-	18-1353	18-1377	-	18-1396	-
250	1997	-	-	-	18-1376	18-1360	-	18-1353	18-1377	-	18-1396	-
275	1985-88	-	-	-	18-1376	18-1360	-	18-1353	18-1377	-	18-1396	-
3.6L	1985-87	-	-	-	18-1376	18-1360	-	18-1353	18-1377	-	18-1396	-
300	1988-95	-	-	-	18-1376	18-1360	-	18-1353	18-1377	-	18-1396	-
2500CC	1988	-	-	-	-	-	-	-	-	-	-	-
2.5L	1982,1984-85	-	-	-	-	-	-	-	-	-	-	-
2.6L	1982-86	18-4718	-	-	-	-	-	-	-	-	-	-
V-4 LOOPER												
120	1985	-	-	18-4076	18-1376	18-1360	-	18-1353	18-1377	-	18-1396	-
120	1985-94	-	-	18-4076	18-1376	18-1360	-	18-1353	18-1377	-	18-1396	-
125	1985-94	-	-	18-4076	18-1376	18-1360	-	18-1353	18-1377	-	18-1396	-
140	1985-94	-	-	18-4076	18-1376	18-1360	-	18-1353	18-1377	-	18-1396	-
1.8L	ALL	-	-	18-4076	-	-	-	-	-	-	-	-
V-6 LOOPER												
225	1986-91	-	-	18-4076	18-1376	18-1360	-	18-1353	18-1377	-	18-1396	-
225	1986-93	-	-	18-4076	18-1376	18-1360	-	18-1353	18-1377	-	18-1396	-
2.7L	1987	-	-	18-4076	-	-	-	-	-	-	-	-
275	1985-88	-	-	18-4076	18-1376	18-1360	-	18-1353	18-1377	-	18-1396	-
300	1985-95	-	-	18-4076	18-1376	18-1360	-	18-1353	18-1377	-	18-1396	-

- ① Except "D" Models
- ② Two Cylinder Models
- ③ Three Cylinder Models
- ④ 90 Degree Models
- ⑤ 60 Degree Models
- ⑥ V-4, V-6 & V-8 Model engines do not include upper bearings in kits

 <p>18-4329 CRANKSHAFT SEAL KIT For: 20-35 HP</p> <table border="1" style="width: 100%; border-collapse: collapse;"> <thead> <tr> <th>HP</th> <th>Years</th> <th>HP</th> <th>Years</th> </tr> </thead> <tbody> <tr> <td>20</td> <td>1981-89</td> <td>30</td> <td>1984-89</td> </tr> <tr> <td>25</td> <td>1977-89</td> <td>35</td> <td>1976-89</td> </tr> <tr> <td>28</td> <td>1986-88</td> <td></td> <td></td> </tr> </tbody> </table>	HP	Years	HP	Years	20	1981-89	30	1984-89	25	1977-89	35	1976-89	28	1986-88			 <p>18-4330 CRANKSHAFT SEAL KIT For: 40-75 HP</p>	 <p>18-4331 CRANKSHAFT SEAL KIT For: Crossflow V-4 - V-6</p>
HP	Years	HP	Years															
20	1981-89	30	1984-89															
25	1977-89	35	1976-89															
28	1986-88																	
 <p>18-4332 CRANKSHAFT SEAL KIT For: 9.9 - 15 HP</p>	 <p>18-8355 CRANKSHAFT SEAL KIT For:</p> <table border="1" style="width: 100%; border-collapse: collapse;"> <thead> <tr> <th>Year</th> <th>Model/HP</th> <th>Year</th> <th>Model/HP</th> </tr> </thead> <tbody> <tr> <td>1990</td> <td>20-30AC, TE, E/ 20-35R/25COMM.</td> <td>1993-96</td> <td>20-35R/25/30TE/ 20-30E</td> </tr> <tr> <td>1991-92</td> <td>25/28/32R, TE, RE</td> <td>1994-96</td> <td>20-30AC,E/ 25COMM./28</td> </tr> </tbody> </table>	Year	Model/HP	Year	Model/HP	1990	20-30AC, TE, E/ 20-35R/25COMM.	1993-96	20-35R/25/30TE/ 20-30E	1991-92	25/28/32R, TE, RE	1994-96	20-30AC,E/ 25COMM./28	 <p>18-1286 UPPER CRANKSHAFT SEAL Replaces: 336232 For: 60° & EFI 90-115HP & 150-175HP</p>				
Year	Model/HP	Year	Model/HP															
1990	20-30AC, TE, E/ 20-35R/25COMM.	1993-96	20-35R/25/30TE/ 20-30E															
1991-92	25/28/32R, TE, RE	1994-96	20-30AC,E/ 25COMM./28															

OUTBOARD