



INSTALLER: PLEASE LEAVE THIS MANUAL FOR THE OWNER'S USE.

Series VSX VSH, VSC[®], and VSCS[®] Models Centrifugal Pumps

TABLE OF CONTENTS

<p>INTRODUCTION 1</p> <p>DESCRIPTION 1</p> <p>PUMP APPLICATION 1</p> <p>OPERATIONAL LIMITS 1</p> <p> Maximum Suction Pressure 1</p> <p> Maximum Working Pressure 1</p> <p>SEAL OPERATING LIMITS 1</p> <p> Mechanical Seals 1</p> <p> Packing 1</p> <p>PUMP IDENTIFICATION 2</p> <p>SAFETY INSTRUCTIONS 3</p> <p>ADDITIONAL SAFETY INSTRUCTIONS 4</p> <p> Electrical Safety 4</p> <p> Thermal Safety 4</p> <p> Mechanical Safety 4</p> <p>GENERAL INSTRUCTIONS 5</p> <p>PURPOSE OF THE MANUAL 5</p> <p>RECEIVING THE PUMP 5</p> <p>STORAGE REQUIREMENTS 5</p> <p>SAFE HANDLING REQUIREMENTS 5</p> <p>LOCATION 7</p> <p> Important 7</p> <p>FOUNDATION 7</p> <p>BASE PLATE SETTING 8</p> <p> Optional Grouting 8</p> <p>ROTATION 8</p> <p>COUPLING ALIGNMENT 8</p> <p> To align using straight edge and calipers 9</p> <p> To align using dial indicator 10</p> <p> Final Alignment 12</p> <p>SUCTION AND DISCHARGE PIPING 12</p> <p> Suction Piping 13</p> <p> Valves in Suction Piping 14</p> <p> Discharge Piping 14</p> <p> Pressure Gauges 15</p> <p> Pump Insulation 15</p> <p>PUMP SEALING 15</p> <p> Mechanical Seals 15</p> <p> Packing 15</p> <p>VEE-CUT IMPELLER TRIMS 16</p> <p>OPERATION 18</p> <p>FLUSHING 18</p> <p>FILLING 18</p> <p>PRIMING 18</p> <p>PRE-START CHECKS 18</p> <p>STARTING 19</p> <p>OPTIONAL CHECKLIST 19</p> <p>FREEZE PROTECTION 19</p> <p>FIELD TESTS 19</p> <p>MAINTENANCE 20</p> <p>GENERAL MAINTENANCE AND PERIODIC INSPECTION 20</p> <p>LUBRICATION 20</p> <p> Pump Bearings 20</p> <p> Couplings 20</p> <p>SEAL INFORMATION 20</p> <p> Mechanical Seals 20</p> <p> Packing (Non-Asbestos) 20</p> <p>MAINTENANCE OF FLOOD DAMAGED PUMPS 21</p>	<p>TROUBLESHOOTING 22</p> <p>GUARDS 24</p> <p> ANSI/OSHA COUPLING GUARD REMOVAL/INSTALLATION 24</p> <p> Removal 24</p> <p> Installation 24</p> <p> BRACKET GUARDS 25</p> <p>SERVICE 26</p> <p> GENERAL DISASSEMBLY PROCEDURES 27</p> <p> SHUTDOWN 27</p> <p> DISASSEMBLY PROCEDURE TO REMOVE BEARING FRAMES - ALL PUMPS 27</p> <p> DISASSEMBLY PROCEDURE TO REMOVE STANDARD MECHANICAL SEALS 28</p> <p> DISASSEMBLY PROCEDURE TO REMOVE STUFFING BOX AND PACKING 29</p> <p> DISASSEMBLY PROCEDURE TO REMOVE CARTRIDGE SEALS 29</p> <p> DISASSEMBLY PROCEDURE TO REMOVE COVERPLATES AND SHAFT ASSEMBLY - ALL PUMPS 30</p> <p> ASSEMBLY PROCEDURE TO INSTALL COVERPLATES AND SHAFT ASSEMBLY - ALL PUMPS 30</p> <p> ASSEMBLY PROCEDURE TO INSTALL STANDARD MECHANICAL SEALS 32</p> <p> ASSEMBLY PROCEDURE TO INSTALL STUFFING BOX AND PACKING 33</p> <p> ASSEMBLY PROCEDURE TO INSTALL CARTRIDGE SEALS 33</p> <p> ASSEMBLY PROCEDURE TO INSTALL BEARING FRAMES - ALL PUMPS 34</p> <p> GENERAL ASSEMBLY INSTRUCTIONS 35</p> <p> TO CHANGE ROTATION 36</p> <p> TO CHANGE STANDARD MECHANICAL SEALS ... 37</p> <p> TO CHANGE CARTRIDGE SEALS 37</p> <p> TO CHANGE THE PACKING OR SLEEVE 37</p> <p> ORDERING PARTS 37</p> <p> DEALER SERVICING 37</p> <p>NOTE: The information contained in this book is intended to assist operating personnel by providing information about the characteristics of the purchased equipment. It does not relieve the user of their responsibility of using accepted engineering practices in the installation, operation, and maintenance of this equipment.</p> <p>For additional questions, contact</p> <p>BELL & GOSSETT (847) 966-3700</p> <p>http://www.bellgossett.com</p>
---	---

INTRODUCTION

DESCRIPTION

The Series VSX centrifugal pumps are frame-mounted pumps that feature high efficiency, rugged construction, compact design, foot-mounted volute, alignment-friendly coupling, and unitized seals. These features, along with the vertically split case make installation, operation, and service easy to perform.

⚠ WARNING: This product can expose you to chemicals including Lead, which is known to the State of California to cause cancer and birth defects or other reproductive harm. For more information go to: www.P65Warnings.ca.gov.

PUMP APPLICATION

The standard Series VSX centrifugal pump's bronze fitted construction makes it ideal for service with the following liquids: hydronic cooling or heating, boiler feed water, condensate, pressure boosting, general pumping, unheated domestic and fresh water, and benign liquids.

For other applications contact your local Bell & Gossett representative.

OPERATIONAL LIMITS

Unless special provisions have been made for your pump by Bell & Gossett, the operational limits for Series VSX pumps are as follows:

Maximum Suction Pressure

Table 1 shows the maximum suction pressures allowed for pump size and seal type:

Table 1: Maximum Suction Pressures

	Unitized Seal	Balanced Seal
2" Seal Sizes 4x6x10.5 5x6x10.5 5x6x13.5 6x8x10.5 6x8x13.5 8x10x10.5	175 psi	300 psi
2.5" Seal Sizes 8x10x13.5 10x12x10.5 10x12x13.5	175 psi	300 psi
3" Seal Sizes 12x14x13.5 14x16x13.5	160 psi	300 psi
3.5" Seal Sizes 12x14x17.5	125 psi	300 psi

Maximum Working Pressure

Listed on pump nameplate.

SEAL OPERATING LIMITS

Mechanical Seals

NOTE: For use on closed or open systems that are relatively free of dirt and/or other abrasive particles.

Unitized EPR/Car/SiC: 0°F to 300°F
Temperature range; 6.5 to 8.5 pH range

Unitized Viton/Car/SiC: 0°F to 225°F
Temperature range; 6.5 to 8.5 pH range

Unitized EPR/Graphite Loaded SiC: 0°F to 300°F
Temperature range; 7 to 12.5 pH range

Balanced EPR/Graphite Loaded SiC: 0°F to 300°F
Temperature range; 7 to 12.5 pH range

Balanced Viton/Graphite Loaded SiC: 0°F to 225°F
Temperature range; 7 to 12.5 pH range



CAUTION: Equipment Damage

To prevent premature seal failure or possible injury, the unitized seals should not be used as an alternate or substitute for the balanced seals installed in a high suction pressure rated VSX pump.

Failure to follow these instructions could result in serious property damage and/or moderate personal injury.

Packing

NOTE: For use on open or closed systems that require a large amount of makeup water, as well as systems that are subjected to widely varying chemical conditions and solids buildup.

Braided Graphite PTFE:
0°F to 200°F Temperature range; 7 to 9 pH range

PUMP IDENTIFICATION

Bell & Gossett pumps are designated by a series of numbers such as Series VSX, Model VSH, VSC, or VSCS. The pump nameplate gives identification and rating information as shown in Figures 1 and 2.

Permanent records for this pump are referenced by the serial number and it must be used with all correspondence and spare parts orders.

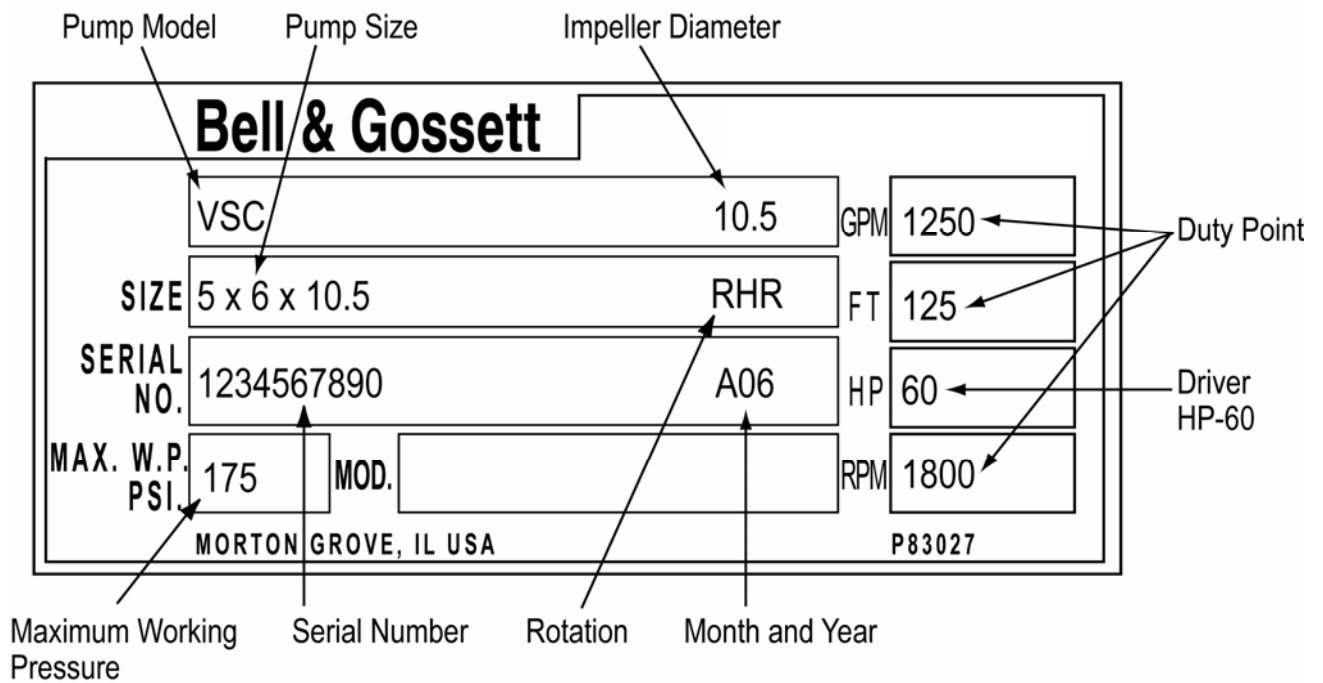

Figure 1: Rating Plate



Figure 2: Suction Limitation

SAFETY INSTRUCTIONS



SAFETY INSTRUCTION

This safety alert symbol will be used in this manual and on the pump safety instruction decals to draw attention to safety related instructions. When used the safety alert symbol means ATTENTION! BECOME ALERT! YOUR SAFETY IS INVOLVED!

FAILURE TO FOLLOW THE INSTRUCTIONS MAY RESULT IN A SAFETY HAZARD.

Your Series VSX pump should have the following safety instruction decals located approximately as shown. If the decals are missing or illegible contact your local Bell & Gossett representative for a replacement.

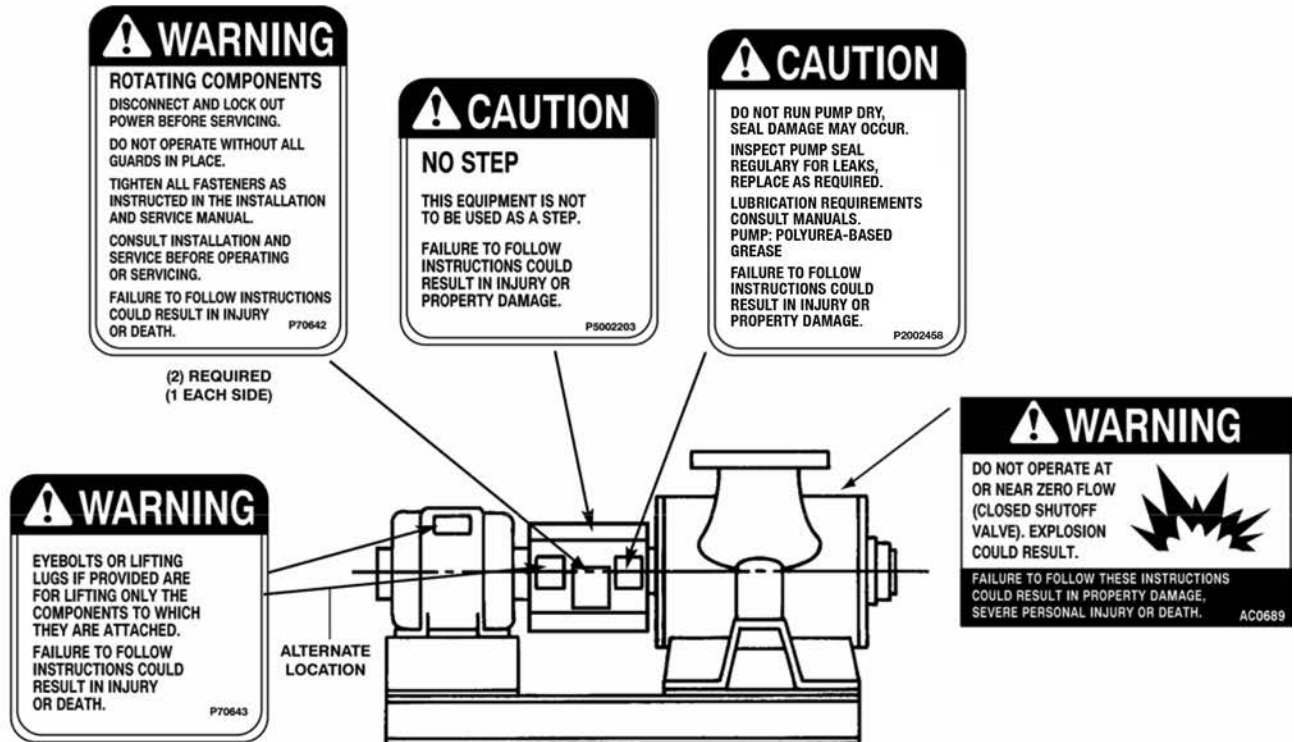

Figure 3: Safety Instruction Decals

ADDITIONAL SAFETY INSTRUCTIONS

Electrical Safety



WARNING: Electrical Shock Hazard

Electrical connections to be made by a qualified electrician in accordance with all applicable codes, ordinances, and good practices.

Failure to follow these instructions could result in serious personal injury or death, or property damage.



WARNING: Rotating Components Hazard

Do not operate the pump without all guards in place.

Failure to follow these instructions could result in serious personal injury or death, or property damage.



WARNING: Electrical Overload Hazard

Three-phase motors must have properly sized heaters to provide overload and under voltage protection. Single-phase motors have built-in overload protectors.

Failure to follow these instructions could result in serious personal injury or death, or property damage



WARNING: Excessive System Pressure Hazard

The maximum working pressure of the pump is listed on the nameplate. Do not exceed this pressure.

Failure to follow these instructions could result in serious personal injury or death, or property damage.

Thermal Safety



WARNING: Extreme Temperature Hazard

If pump, motor, or piping are operating at extremely high or low temperatures, guarding or insulation is required.

Failure to follow these instructions could result in serious personal injury or death, or property damage.



WARNING: Excessive Pressure Hazard Volumetric Expansion

The heating of water and other fluids causes volumetric expansion. The associated forces may cause failure of system components and release of high temperature fluids. This will be prevented by installing properly sized and located compression tanks and pressure relief valves.

Failure to follow these instructions could result in serious personal injury or death, or property damage.

Mechanical Safety



WARNING: Unexpected Startup Hazard

Disconnect and lockout power before servicing.

Failure to follow these instructions could result in serious personal injury or death, or property damage.

GENERAL INSTRUCTIONS

PURPOSE OF THE MANUAL

This manual is furnished to acquaint you with some of the practical ways to install, operate, and maintain this pump. Read it completely before any installation, operation, or maintenance on your unit and keep it handy for future reference.

Equipment cannot operate well without proper care. To keep this unit at top efficiency, follow the recommended installation and servicing procedures outlined in this manual.

RECEIVING THE PUMP

Check the pump for shortages and damage immediately upon arrival. (An absolute must!) Prompt reporting of any damage to the carrier's agent, with notations made on the freight bill, will expedite satisfactory adjustment by the carrier. Pumps and drivers are normally shipped from the factory mounted on a base plate and painted with primer and one finish coat. Couplings may either be completely assembled or have the coupling hubs mounted on the shafts and the connecting members removed. When the connecting members are removed, they will be packaged in a separate container and shipped with the pump or attached to the base plate.

Shafts are in alignment when the unit is shipped; however, due to shipping, the pumps may arrive misaligned. Alignment must be established during installation. Bell & Gossett has determined that proper and correct alignment can only be made by accepted erection practices. (See the Foundation, Baseplate Setting, and Coupling Alignment sections.)

STORAGE REQUIREMENTS

If the unit will not be installed and put into operation immediately upon arrival at the site, or for an extended shutdown after the unit is in operation, the following requirements for short-term storage apply:

- Store in a covered and dry location.
- Store the unit free from excessive cold or heat (below 32°F and above 110°F), dirt, and vibration.
- Rotate the shaft by hand several times (10-15 turns) at least every 30 days.

For initial storage longer than three months, or for pump shut down after being in operation longer than three months, contact your local sales and service representative for long-term storage guidelines.

SAFE HANDLING REQUIREMENTS



WARNING: Falling Objects Hazard

Eyebolts or lifting lugs, if provided, are for lifting only the components to which they are attached.

- Personal protective equipment should be worn when handling this equipment.
- Transportation & installation of this equipment should only be performed by qualified personnel.
- A professional rigging company should be consulted before lifting the pump assembly.
- Only use properly sized, certified lifting equipment & lifting devices, including slings, suitably rated for the weights to be lifted.
- Slings, when used, must be of identical materials to avoid differences in stretch rates.
- Do not use lifting devices that are frayed, kinked, unmarked, or worn.
- Lifting eyebolts fitted on single components of the assembly (pump or motor) must not be used to lift the complete assembly.

Failure to observe these instructions could result in equipment or property damage, serious injury, or death.

The pump assembly can arrive in a variety of ways. It can be shipped as pump end only (bare pump), pump less motor, or pump, motor, & baseplate. Use the following recommended ways of handling VSX pump assemblies.

The pump assembly should remain horizontal during transport and lifting.

Lifting the pump end only (bare pump) should be done by placing one end of the slings around or as close to the volute barrel as possible (See Fig. 4a). After the slings are attached to the unit, re-check to ensure they are securely in place. Make sure the slings are adjusted to obtain an even lift.

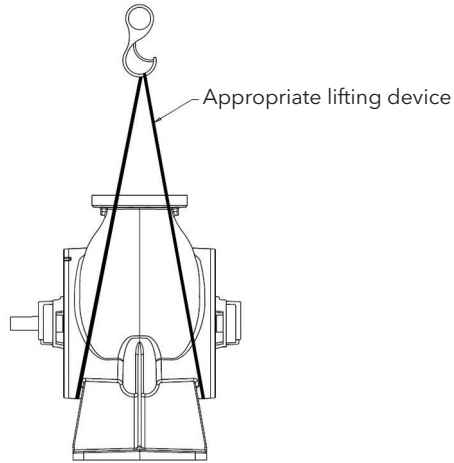

Figure 4a

Lifting the pump less motor or the pump, motor, & baseplate should be done by utilizing a forklift under the entire unit (Fig. 4b). Always take extra precaution to ensure the weight is balanced & equally distributed across both forks. When the baseplate of the assembly is structural channel construction, the pump and base plate should be set in place first. The motor should then be separately lifted & mounted to the unit.

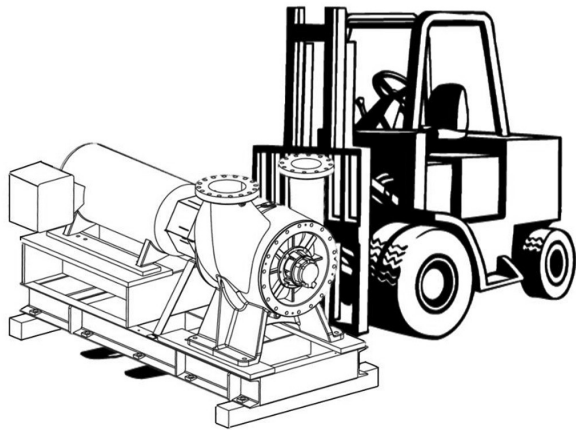

Figure 4b

As an alternative to lifting by forklift, lifting devices can be used to lift the complete pump & motor assemblies. When lifting the complete pump assembly (Fig. 4c), securely place the lifting devices around the volute barrel or nozzle. The remainder of the lifting device should be placed under the back end of the motor housing (as close to the motor feet as possible). Precaution should be taken to ensure the placement of the lifting devices will not damage the motor end bell and conduit boxes.

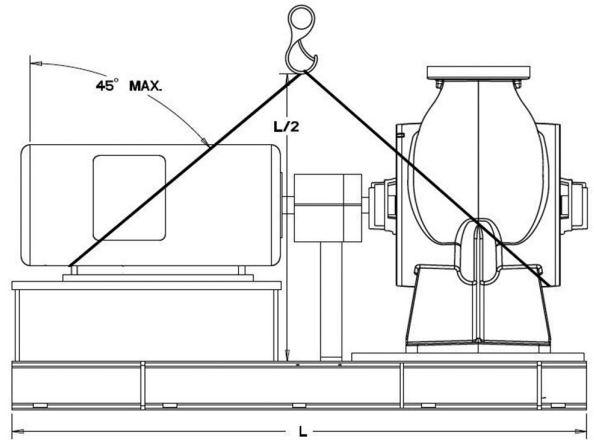

Figure 4c

LOCATION

Locate the pump so there is sufficient room for inspection, maintenance, and service. If the use of a hoist or tackle is needed, allow ample head room. For outdoor installations, it is advisable to shelter the pump unit.



WARNING: Falling Objects Hazard

Eyebolts or lifting lugs, if provided are for lifting only the components to which they are attached.

Failure to follow these instructions could result in serious personal injury or death, or property damage.

The best pump location for sound and vibration absorption is on a concrete floor with subsoil underneath. If the pump location is overhead, special precautions should be undertaken to reduce possible sound transmission. Consult a sound specialist.

If the pump is not on a closed system, it should be placed as near as possible to the source of the liquid supply, and located to permit installation with the fewest number of bends or elbows in the suction pipe.

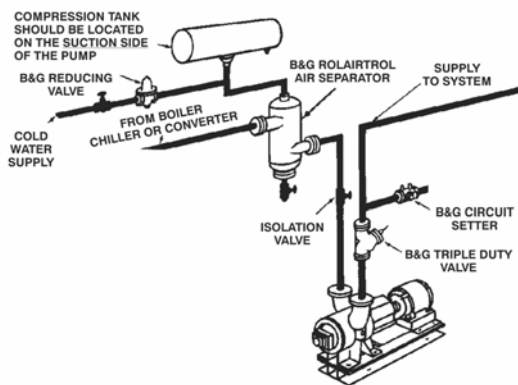

Figure 5: Pump Location

The installation must be evaluated to determine that the Net Positive Suction Head Available (NPSHA) meets or exceeds the Net Positive Suction Head Required (NPSHR), as stated by the pump performance curve.

The pump must be primed before starting. Whenever possible, the pump should be located below the fluid level to facilitate priming and ensure a steady flow of liquid. This condition provides a positive suction head on the pump. It may also be possible to prime the pump by pressurizing the suction vessel.

Important

Do not install and operate Bell & Gossett Pumps, 3D Valves, Suction Diffusers, etc., in closed systems unless the system is constructed with properly sized safety devices and control devices. Such devices include the use of properly sized and located pressure relief valves, compression tanks, pressure controls, temperature controls, and flow controls as appropriate. If the system does not include these devices, consult the responsible engineer or architect before making pumps operational.

FOUNDATION

The concrete foundation or isolation pad must be substantial enough to absorb vibration (*Hydraulic Institute Standards* recommends that the foundation weigh at least five times the weight of the pump unit). It must form a permanent and rigid support for the base plate and should be built to suit local conditions. This is important in maintaining the alignment of the flexibly coupled unit. Do not use the base as the isolation pad.

Foundation bolts of the proper size should be embedded in the concrete with either of the methods shown in Figure 6. See Table 2 for anchor bolt hole and anchor bolt sizes. Allow the foundation to cure for several days before proceeding with the pump installation.

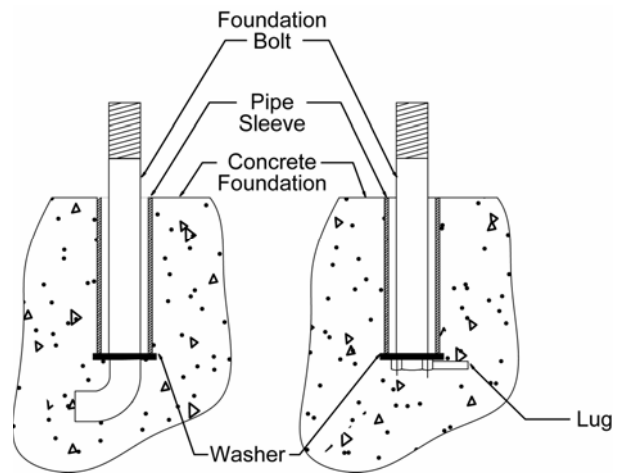

Figure 6: Foundation

Table 2: Anchor Bolt/Hole Sizes

Diameter of Anchor Bolt Hole	Diameter of Anchor Bolt
1.125"	1.000"
1.375"	1.250"

BASE PLATE SETTING

Place the pump unit on its concrete foundation, supporting it with steel wedges or shims. The wedges or shims should be machined and be put on both sides of each anchor bolt to provide a means for leveling the base. The wedge or shim width should be equal to or greater than the base rail width. The length of the wedge or shim should be at least four times the diameter of the anchor bolt. It is acceptable to place additional shims between the existing anchor bolts.

Use an anchor bolt for each anchor bolt hole provided, and plain, flat Type-W washers at each anchor bolt.



CAUTION: Equipment Damage

Use an anchor bolt and plain, flat Type-W washer at each anchor bolt hole. Otherwise, shifting of the pump unit may occur.

Failure to follow these instructions could result in serious property damage and/or moderate personal injury.

It is very important that the pump base be set level to avoid any mechanical difficulties with the motor or pump. This pump was properly aligned (if furnished with a motor) at the factory. However, since all pump bases are flexible, they may spring and twist during shipment. Do not pipe the pump until it is realigned. After piping is completed and after the pump is installed and bolted down, align it again. It may be necessary to re-adjust the alignment from time to time while the unit and foundation are new.

Optional Grouting

It is permissible to grout the base after the pump unit has been leveled, securely bolted to the floor, and properly aligned. A good grade of non-shrinking grout should be used inside the pump base.

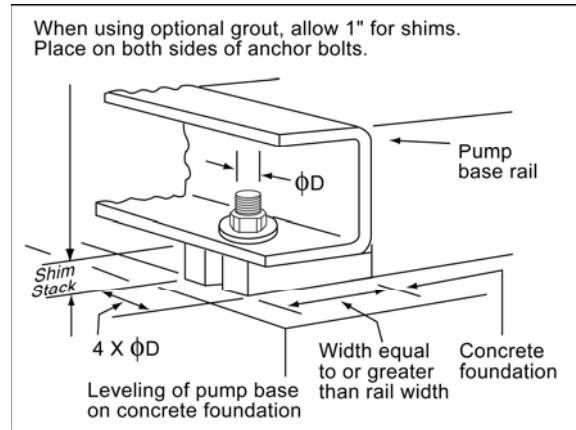

Figure 7: Setting Base Plate

ROTATION

The Series VSX pump is available in both right- and left-hand rotation. An arrow cast into the pump body shows the direction of rotation.

COUPLING ALIGNMENT

All alignment should be done by moving or shimming the motor only. Adjustments in one direction may alter alignment in another. Therefore, check alignment in all directions after a correction is made. All measurements should be taken with the pump and motor bolts tightened. Final alignment check should be made after the unit has attained its final operating temperature.



WARNING: Unexpected Startup Hazard

Disconnect and lockout power before servicing.

Failure to follow these instructions could result in serious personal injury or death, or property damage.

1. Check the pump and motor shafts and remove any paint, burrs, rust, etc. Slide the hubs (and bushings, QD or Taper-Lock style) on the shafts with keys.
2. When high speed rings are used for spacer couplings, loosely install one ring on each half element.

3. Hold one half element on the hubs to determine the appropriate hub spacing. If using spacer elements with high speed rings, hold both half elements on the hubs to make sure the hubs do not interfere with the rings. The hubs may be installed with the hub extension facing in or out. Make sure the shaft extends into the hubs at least .8 times the diameter of the shaft.
4. **Lightly** fasten the hubs to the shafts to prevent them from moving during alignment.
5. The hubs should be aligned to at least the values shown in Figure 10 for allowable misalignments. Alignment may be done with lasers, dial indicators, or with a straight edge and calipers.

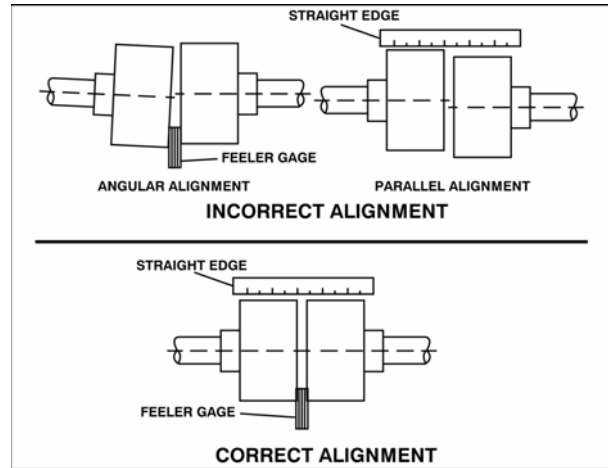

Figure 8: Checking Alignment with Straight Edge

To align using straight edge and calipers

Angular misalignment may be checked by using a caliper to gauge the distance between the two hubs at various points around the circumference. **Do not rotate the shafts.** Reposition the equipment until the difference between the minimum and maximum distance values is within the permissible value.

Angular misalignment may also be checked by inserting feeler gauges between the coupling faces at various points around the circumference. **Do not rotate the shafts.** Reposition the equipment until the difference between the minimum and maximum distance values is within the permissible value.

Parallel alignment may be checked by placing a straight edge across the two hubs and measuring the maximum offset at various points around the periphery of the hubs. **Do not rotate the shafts.** Reposition equipment until the offset is within the permissible value.

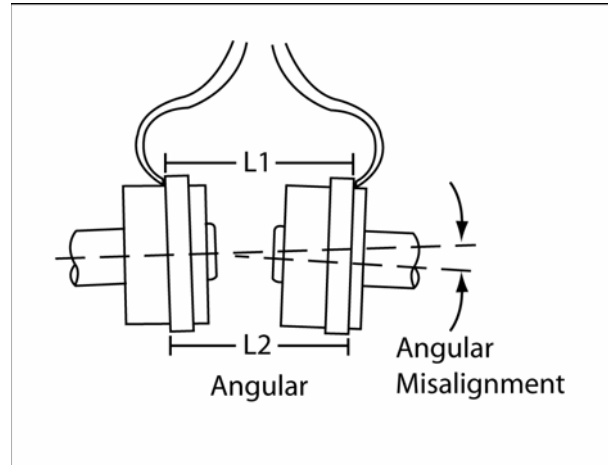

Figure 9: Checking Alignment with Calipers

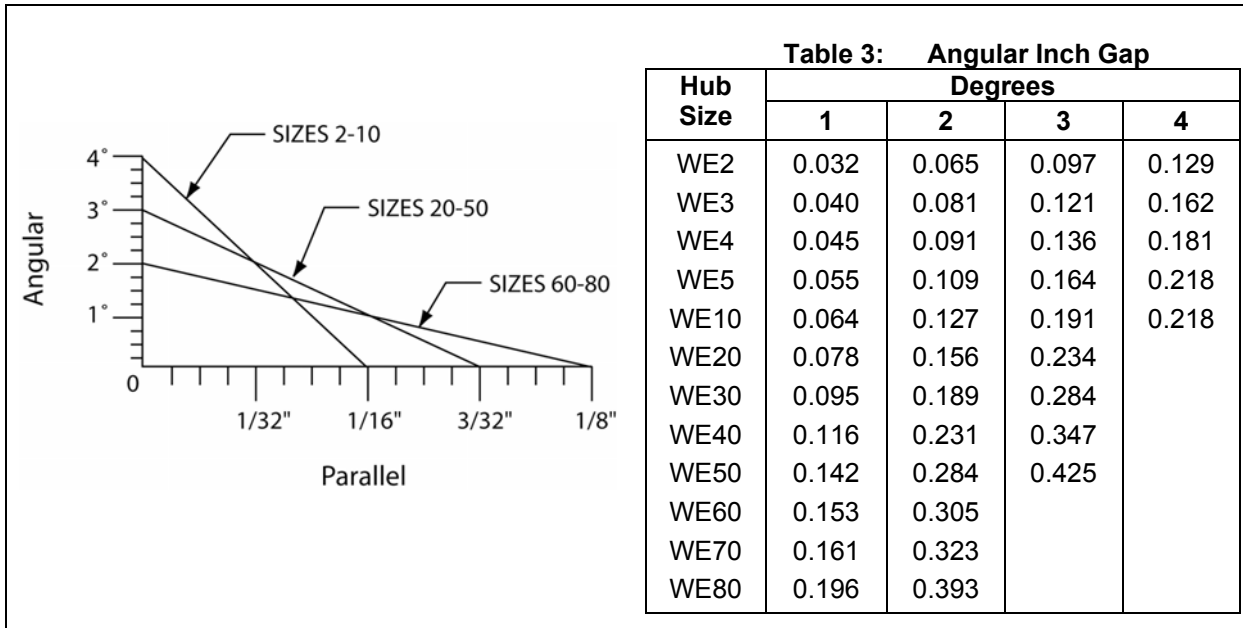

Figure 10: Maximum Allowable Misalignment for Wood's Duraflex®¹ Couplings

Example: A WE10 coupling with a 3° angular misalignment will have a .191" difference in measurements between L1 and L2. (See Figure 9.)

To align using dial indicator

Angular misalignment may be checked by mounting the dial indicator base to one coupling half, or shaft, and positioning the dial indicator button on the front face or rear face of the opposite coupling half. Scribe index lines on coupling halves as shown in Figure 11. Set the dial to zero. Rotate both coupling halves together, making sure the index lines remain matched. Reposition the equipment until the offset is within the permissible value.

Parallel misalignment may be checked by mounting the dial indicator base to one coupling half, or shaft, and positioning the dial indicator button on the outside diameter of the opposite coupling half. Set the dial to zero. Rotate both coupling halves together, making sure the index lines remain matched. Reposition the equipment until the offset is within the permissible value.

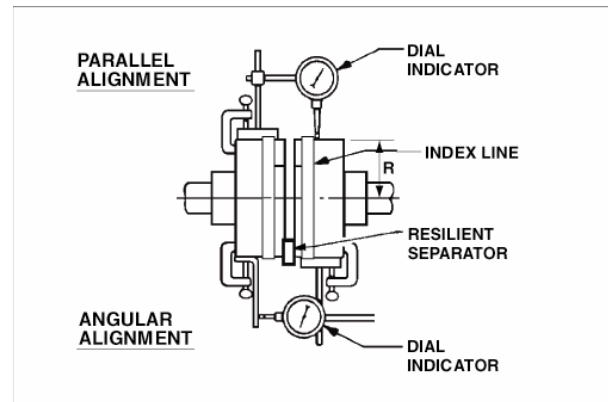

Figure 11: Checking Alignment with Dial Indicators

- Recheck the hubs to be certain both angular and parallel alignments are still within the values given in Figure 10.
- Loosen the set screw on the pump hub. Loosely install one half element opposite the hub set screws. Torque both hub set screws to the value shown in Table 4. For QD or Taper-Lock hubs, follow the instructions supplied with the bushings. Loosely install the other half element onto the hubs. Install capscrews on the high-speed rings. If the capscrews and the holes in the elements do not line up

¹ Duraflex is a registered trademark of T.B. Wood's, Inc.

properly due to hub misalignment, rotate the shafts slightly. Torque all element and high speed ring capscrews to the values shown in Table 4. If possible, recheck angular and parallel alignments.

⚠ WARNING: Flying Objects Hazard

Coupling capscrews and set screws are to be installed using torque wrench or other torque measuring device. Hardware not installed per the listed torque values may become loose and dislodge from coupling assembly.

Failure to follow these instructions could result in serious personal injury or death, or property damage.

8. Capscrews supplied with the coupling have a thread lock coating that aids in resisting loosening from vibration. The capscrews should not be reused more than four times or if the coating is absent. Replacement capscrews are to be purchased through your local Bell & Gossett representative.

⚠ WARNING: Flying Objects Hazard

Capscrews with damaged or absent thread lock coating should be not be used. Otherwise the required counterforce will not be achieved and hardware may become loose and dislodge from coupling assembly.

Failure to follow these instructions could result in serious personal injury or death, or property damage.

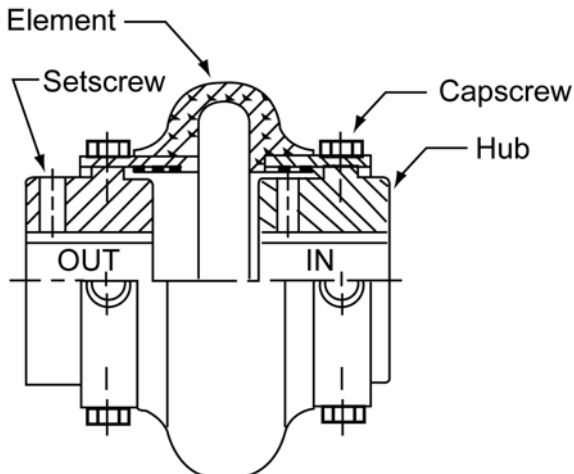

**Figure 12: Woods Duraflex Coupling
- Typical Non-spacer**

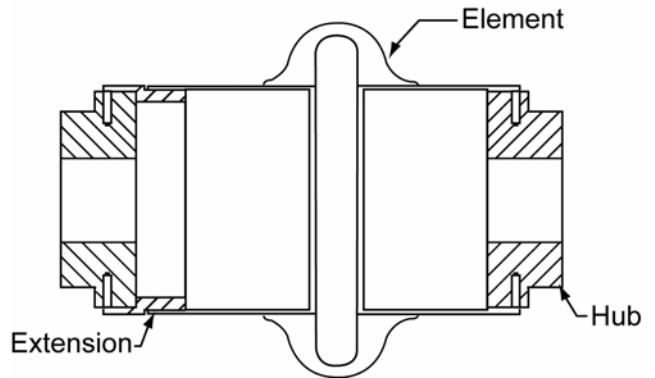

**Figure 13: Woods Duraflex Coupling
- Typical Spacer**

Table 4: Fastener Torque Values and Maximum RPM for Woods Duraflex Couplings

Basic Size	Element & Ring Capscrew Torque (ft-lb)	Standard Hubs Set screw Torque (ft-lb)	Maximum RPM	
			Standard	Spacer
WE2	17	7	7500	1800
WE3		7	7500	1800
WE4		14	7500	1800
WE5		23	7500	1800
WE10	30	23	7500	1800
WE20		50	6600	1800
WE30		50	5800	1800
WE40		100	5000	1800
WE50	75	100	4200	1800
WE60		167	3800	1800
WE70		167	3600	1800
WE80		167	2000	1800

Final Alignment

Final alignment cannot be accomplished until the pump has been operated initially for a sufficient length of time to attain operating temperature. When normal operating temperature has been attained, secure the pump to re-check alignment and compensate for temperature accordingly. (See the section entitled **Coupling Alignment**.)

NOTE: Elastomeric couplings are specifically designed to accommodate angular shaft misalignment, as well as parallel offset of the pump and motor shafts. However, the amount of the offset and/or misalignment is dependent on the style of flexible coupling applied. Left unchecked, coupling misalignment has a significant impact on the overall life of the mechanical seals and the bearings of the pump.



WARNING: Rotating Components Hazard

Do not operate pump without all guards in place.

Failure to follow these instructions could result in serious personal injury or death, or property damage.

SUCTION AND DISCHARGE PIPING

When installing piping, refer to the *Hydraulics Institute Standards* and observe the following precautions:

Piping should always be run to the pump.

Do not move pump to the pipe. This could make final alignment impossible.

Both the suction and discharge piping should be supported independently near the pump and properly aligned so that no strain is transmitted to the pump when the flange bolts are tightened. Use pipe hangers or other supports at necessary intervals to provide support. When expansion joints are used in the piping system they must be installed beyond the piping supports closest to the pump. Tie bolts should be used with expansion joints to prevent pipe strain. Do not install expansion joints next to the pump or in any way that would cause a strain on the pump resulting from system pressure changes.

Install the piping as straight as possible, avoiding unnecessary bends. Where necessary, use 45° or long sweep 90° fittings to decrease friction losses.

Make sure that all piping joints are leak tight.

Where flanged joints are used, ensure that inside diameters match properly.

Remove burrs and sharp edges when making up joints.

Do not “spring” piping when making any connections. Coupling and bearing wear will result if the suction or discharge lines are forced into position.

When considerable temperature changes are anticipated, equipment for absorbing expansion should be installed in the system in such a way as to avoid strain on the pump.

When using an isolation pad, flexible piping should also be used on both the suction and discharge sides of the pump.

The pipeline should have isolation valves around the pump and have a drain valve in the suction pipe.

See Technical Bulletin B-876 or BX-876, Table 5 for allowable static flange loading for vertical flange configuration. (Models VSC and VSCS)

A Bell & Gossett Triple Duty Valve installed in the discharge line will serve as a check valve to protect the pump from water hammer, as a gate valve for servicing, and for throttling.

Suction Piping

When installing the suction piping, refer to the *Hydraulics Institute Standards* and observe the following precautions. (See Figure 14.)

The sizing and installation of the suction piping is extremely important. It must be selected and installed so that pressure losses are minimized and sufficient liquid will flow into the pump when started and operated. Many NPSH (Net Positive Suction Head) problems can be directly attributed to improper suction piping systems.

Friction losses caused by undersized suction piping can increase the fluid's velocity into the pump. Refer to the *Hydraulic Institute Standards* for inlet pipe sizing and velocity requirements.

Elbows in the suction piping for horizontal double suction pumps should be installed per the *Hydraulics Institute Standards* as there is always an uneven turbulent flow around an elbow. When it is in a position other than the vertical (in relation to the pump suction nozzle) it causes more liquid to enter one side of the impeller than the other. (See Figure 15.) This results in high unequalized thrust loads that will overheat the bearings and cause rapid wear, in addition to affecting hydraulic performance.

For pipe reducers on the inlet side, no more than one pipe diameter reduction in a single reducer should be used.

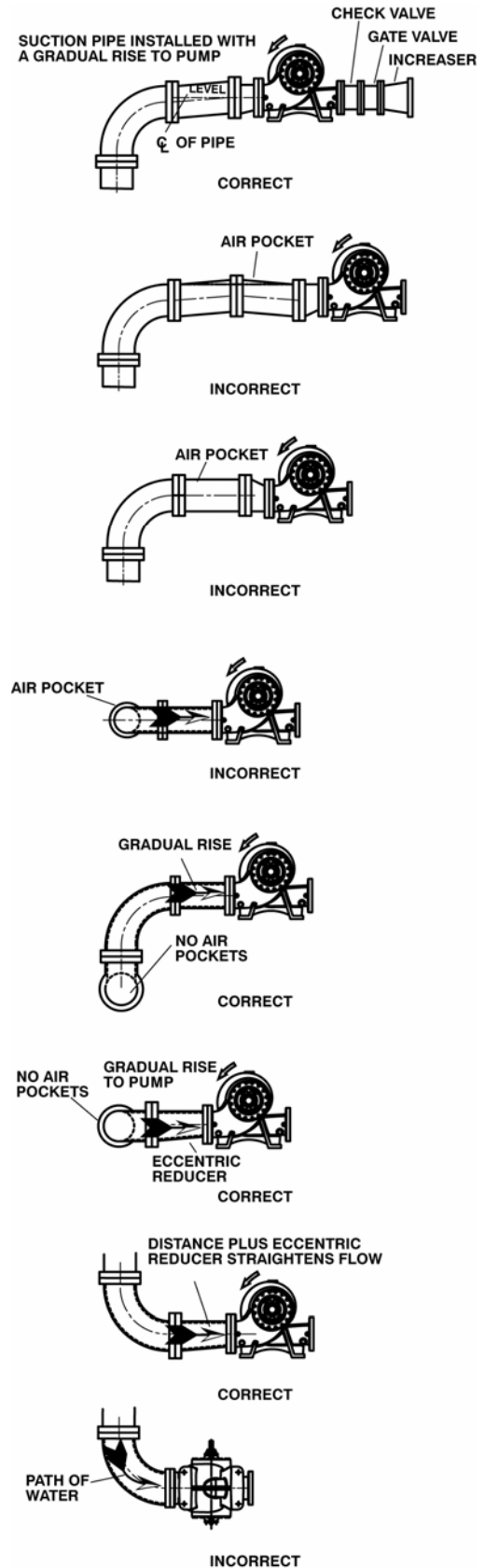

Figure 14: Suction Pipe Installations
(Piping supports not shown)

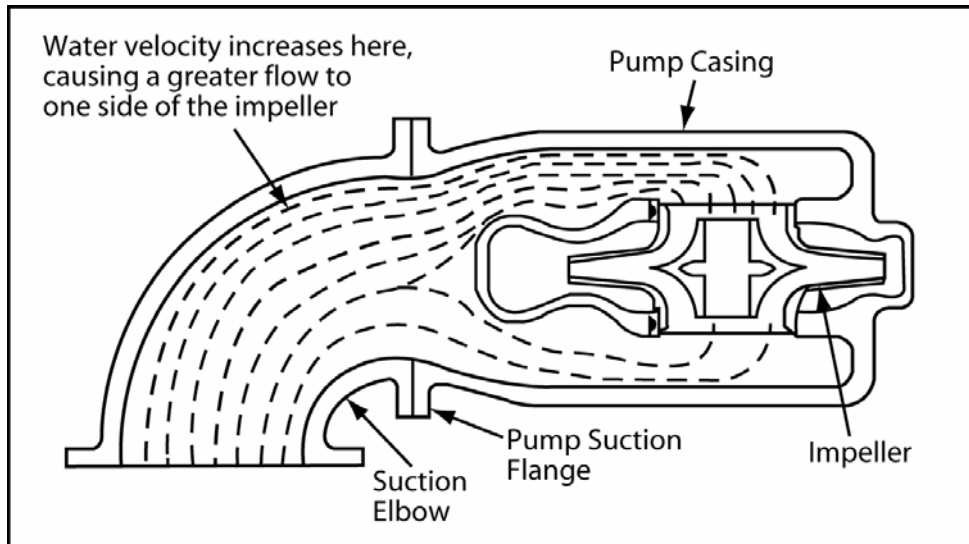

Figure 15: Unbalanced Loading of a Double Suction Impeller Due to Uneven Flow Around an Elbow Adjacent to the Pump

When operating on a suction lift, the suction pipe should slope upward to the pump nozzle. A horizontal suction line must have a gradual rise to the pump. Any high point in the pipe can become filled with air and thus prevent proper operation of the pump.

To facilitate cleaning the pump's liquid passage without dismantling the pump, a short section of pipe (Dutchman or spool piece), designed so that it can be readily dropped out of the line, can be installed adjacent to the suction flange. With this arrangement, any matter clogging the impeller is accessible by removing the spool piece (or pipe section).

Valves in Suction Piping

When installing valves in the suction piping, observe the following precautions:

Suction piping valves should be placed right before the run of recommended straight pipe.

If the pump is operating under static suction lift conditions, a foot valve may be installed in the suction line to avoid the necessity of priming each time the pump is started. This valve should be of the flapper type, rather than the multiple spring type, sized to avoid excessive friction in the suction line. The foot valve and pipe should be sized to maximize NPSHa to the pump by minimizing suction line losses.

Check valves are placed in the discharge piping in normal applications. Before using a check valve in the suction piping, consider the added pressure drop to the pump, potential water hammer, and the chance of allowing the entire pump volute to be exposed to the discharge pressure.

When foot valves are used, or where there are other possibilities of "water hammer," close the discharge valve slowly before shutting down the pump.

The pump must never be throttled by the use of a valve on the suction side of the pump. Suction valves should be used only to isolate the pump for maintenance purposes, and should always be installed in positions to avoid air pockets.

Discharge Piping

The maximum velocity in the discharge piping should not exceed 15 feet per second. If a check valve is present in the outlet piping, this value shall be reduced. System losses, life-cycle costs, and process considerations will usually drive the size of discharge piping and fittings. Some high energy pumps are sensitive to flow disturbing devices mounted close to the pump outlet. Consult Bell & Gossett when in doubt of the minimum required straight pipe length.

Pressure Gauges

Properly sized pressure gauges should be installed in both the suction and discharge nozzles in the gauge taps. The gauges will enable the operator to easily observe the operation of the pump, and also determine if the pump is operating in conformance with the performance curve. If cavitation, vapor binding, or other unstable operation should occur, widely fluctuating discharge pressure will be noted.

Pump Insulation

On applications where pumps are insulated, the pump bearing brackets should not be insulated since this would tend to trap heat inside the housing. This could lead to increased bearing temperatures and premature bearing failures.

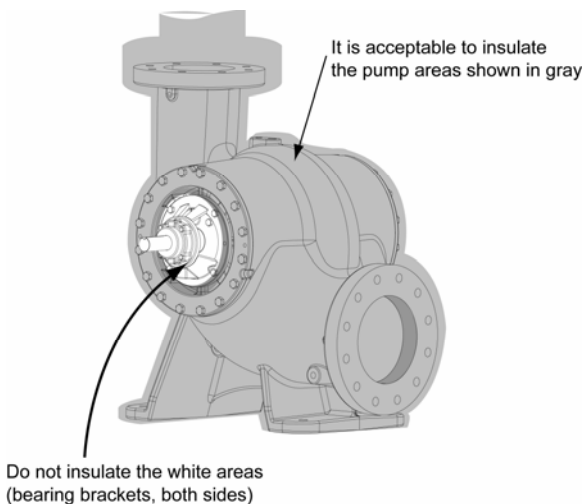

Figure 16: Pump Insulation

PUMP SEALING

Mechanical Seals

Mechanical seals are preferred over packing on some applications because of better sealing qualities and longer serviceability. When a seal is properly installed, it will last longer than packing on similar applications. The change from packing to an alternate arrangement may be made in the field by competent service personnel. Conversion parts may be ordered from your local Bell & Gossett representative.

Packing

Contaminants in the pumped liquid must not enter the stuffing box. These contaminants

may cause severe abrasion or corrosion of the shaft sleeve, and rapid packing deterioration; they can even plug the stuffing box flushing and lubrication system. The stuffing box must be supplied at all times with a source of clean, clear liquid to flush and lubricate the packing.

If the pump system pressure conditions vary during the day, packing adjustment becomes difficult. Consideration should be given to using a mechanical seal.

Standard pumps are normally packed before shipment. If the pump is installed within 60 days after shipment, the packing will be in good condition with a sufficient supply of lubrication. If the pump is stored for a longer period, it may be necessary to repack the stuffing box. In all cases, however, inspect the packing before the pump is started.

NOTE: Packing adjustment is covered in the section entitled **Maintenance**.

On some applications, it is possible to use internal liquid lubrication (pumped liquid) to lubricate packing. Only when all of the following conditions prevail, can this be done:

1. Liquid is clean, free from sediment and chemical precipitation and is compatible with seal materials.
2. Temperature is above 32°F and below 160°F.
3. Suction pressure is below 75 psig.
4. Lubrication (pumped liquid) has lubricating qualities.
5. Liquid is non-toxic and non-volatile.

When the liquid being pumped contains solids or is otherwise not compatible with packing materials, an outside supply of flush liquid should be furnished. In general, external-flush liquid (from an outside source) is required when any of the above conditions cannot be met.

The standard stuffing box consists of rings of packing (See the **Assembly and Disassembly Procedures** section for the number of rings), a lantern ring, and a gland. A shaft sleeve that extends through the box and under the gland is provided to protect the shaft.

A tapped hole is supplied in the stuffing box directly over the lantern ring to introduce a clean, cooling medium. The stuffing box must, at all

times, be supplied with flushing liquid at a high enough pressure to keep the box free from foreign matter, which would quickly destroy the packing and score the shaft sleeve.

Only a sufficient volume of flushing liquid to create a definite direction of flow from the stuffing box inward to the pump casing is required, but the pressure is important. Apply seal water at a rate of approximately .25 GPM at a pressure approximately 15 to 20 psig above the suction pressure. (Approximately one (1) drop per second.)

External flushing liquid should be adjusted to the point where the packing runs only slightly warm, with a very slow drip from the stuffing box. Excess pressure from an external source can be very destructive to packing. More pressure is required, however, for abrasive slurries than for clear liquids. Examination of the leakage will indicate whether to increase or decrease external pressure. If slurry is present in the leakage, increase the pressure until only clear liquid drips from the box. If the drippage is corrosive or harmful to personnel, it should be collected and piped away.

A common error is to open the external piping valve wide and then control the drippage by tightening the packing gland. A combination of both adjustments is essential to arrive at the optimum condition. The life of packing and sleeve depends on careful control more than any other factor.

VEE-CUT IMPELLER TRIMS

A vast majority of the impeller trims are standard straight cuts. However, on several pump sizes a vee-cut is employed for the smaller diameters. (See Figure 17.) For either type of cut, D_{ref} is the

impeller diameter on the nameplate which is chosen from the published performance curves.

A vee-cut is required when the impeller diameter D_{ref} is smaller than the D_{shroud} values shown in Table 5.

D_{shroud} is the trim diameter of the shrouds. This value, as shown in Table 5, is constant for all vee-cut diameters for a given pump size.

D_{hub} is the diameter at the hub (bottom of the vee-cut).

To achieve the performance for a given D_{ref} , trim D_{shroud} to the values in Table 5. Then using the charts in Figure 18, find D_{hub} for the appropriate pump size and D_{ref} .

Example: to trim an 8x10x10.5A impeller to a D_{ref} of 8.000, trim the shrouds to 8.250" (D_{shroud}) per Table 5, and trim the bottom of the vee to 7.750" (D_{ref}) per Figure 18.

Table 5: Required Vee-cuts

Pump Size	D_{shroud}
6x8x10.5A	8.000 in.
8x10x10.5A	8.250 in.
10x12x10.5A	9.750 in.
12x14x13.5A	11.125 in.
14x16x13.5A	12.375 in.

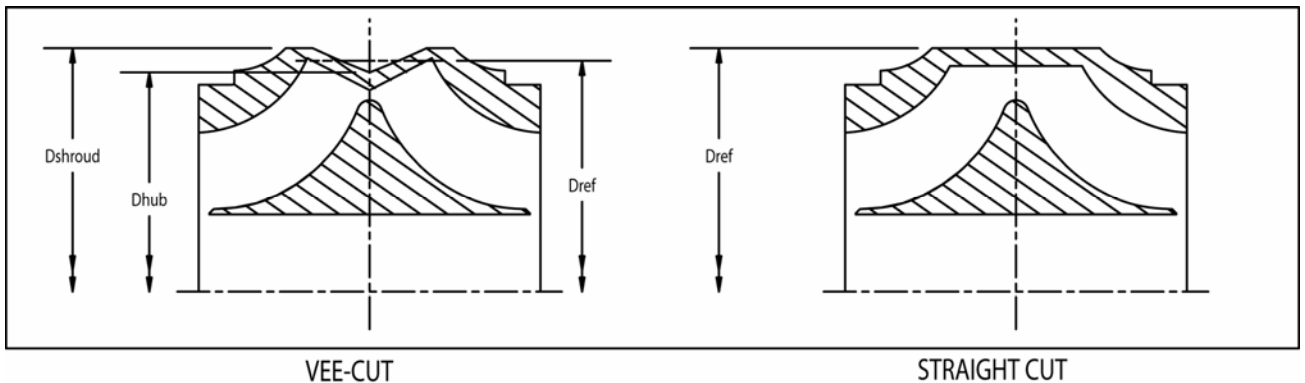

Figure 17: Straight and Vee-cut Impellers

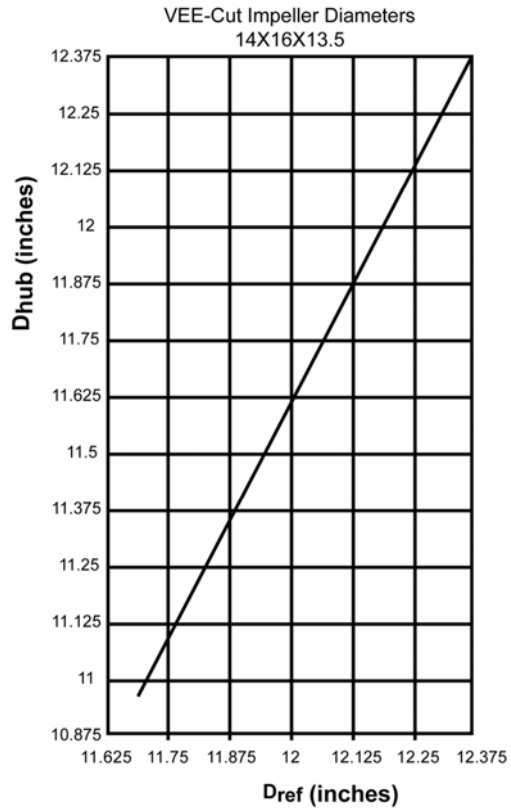
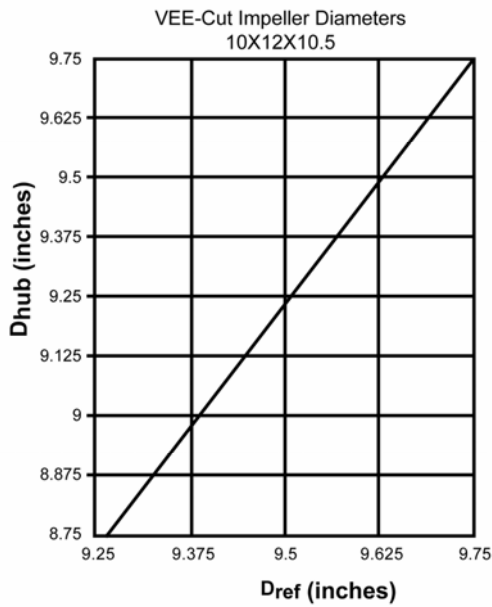
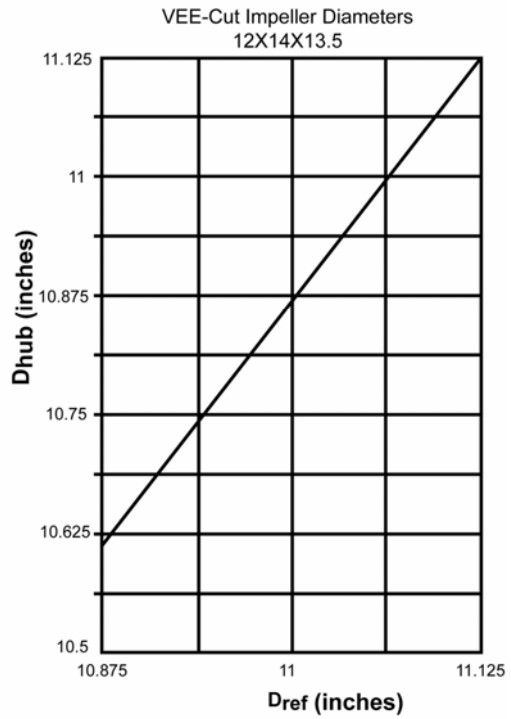
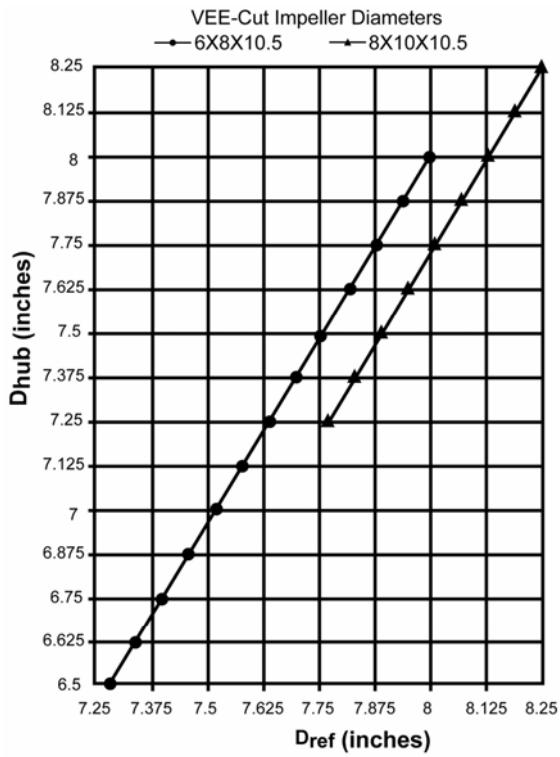

Figure 18: Vee-cut Impeller Diameters

OPERATION

FLUSHING

New and old systems should be flushed to eliminate all foreign matter. Heavy scale, welding splatter and wire or other large foreign matter can clog the pump impeller. This will reduce the capacity of the pump causing cavitation, excessive vibration, and/or damage to close clearance parts (wear rings, seals, sleeves, etc.).

FILLING

Vents should be located at the highest point so entrained gases and air can escape. However, if the gases are flammable, toxic, or corrosive they should be vented to an appropriate place to prevent harm to personnel or other parts of the system. Pipe hangers and anchors should be checked to make sure they are properly set to take the additional weight of the pumpage.

All drains should be closed when filling the system. Filling should be done slowly so that excessive velocities do not cause rotation of the pumping elements that may cause damage to the pump or its driver. The adequacy of the anchors and hangers may be checked by mounting a dial indicator off of any rigid structure not tied to the piping and setting the indicator button on the pump flange in the axial direction of the nozzle. If the indicator moves, as the filling proceeds, the anchors and supports are not adequate or set properly and should be corrected.

PRIMING

If the pump is installed with a positive head on the suction, it can be primed by opening the suction valve and loosening the vent plug on top of the casing (do not remove), allowing air to be purged from the casing.

If the pump is installed with a suction lift, priming must be done by other methods such as foot valves, ejectors, or by manually filling the casing and suction line.



CAUTION: Seal Damage Hazard

Do not run pump dry. Seal damage may occur.

Failure to follow these instructions could result in serious property damage and/or moderate personal injury.

While venting the air from the pump body, the pump shaft should be rotated a few times by hand.

PRE-START CHECKS



WARNING: Unexpected Startup Hazard

Disconnect and lockout power before servicing.

Failure to follow these instructions could result in serious personal injury or death, or property damage.



WARNING: Electrical Shock Hazard

Electrical connections to be made by a qualified electrician in accordance with all applicable codes, ordinances, and good practices.

Failure to follow these instructions could result in serious personal injury or death, or property damage.

Before the initial start of the pump, make the following inspections:

1. Check the alignment between the pump and motor. (See the **Coupling Alignment** section for alignment requirements.)
2. Check all connections to the motor and starting device with the wiring diagram. Check voltage, phase, and frequency on the motor nameplate with the line circuit.
3. Check the suction and discharge piping and the pressure gauges for proper operation.
4. Turn the rotating element by hand to ensure that it rotates freely.
5. Check the stuffing box adjustment, lubrication, and piping (packing seal only).
6. Check the driver lubrication. Refer to the driver installation, operation, and maintenance manual.
7. Ensure that the pump bearings are properly lubricated. See the **Pump Bearings** paragraphs in the **Lubrication** section.
8. Ensure that the coupling is properly lubricated, if required. See the **Couplings** paragraph in the **Lubrication** section.
9. Ensure that the pump is full of liquid and that all valves are properly set and operational, with the discharge valve closed and the suction valve fully open. Purge all air from the top of the casing.

10. Check rotation. Be sure that the driver operates in the direction indicated by the arrow on the pump casing as serious damage can result if pump is operated with incorrect rotation. Check rotation each time the motor leads have been disconnected.



WARNING: Rotating Components Hazard

Do not operate pump without all guards in place.

Failure to follow these instructions could result in serious injury or death, or property damage.

STARTING

1. Close drain valves and valve in discharge line.
2. Open fully all valves in the suction line.
3. Slowly turn on flush water to the stuffing box. (If pumped fluid is dirty or if leakage of air is to be prevented, these lines should be always left open.)
4. Prime the pump.
5. Start the pump driver (turbines and engines may require warming up; consult the manufacturer's instructions).

NOTE: If the pump loses prime during start-up, it should be shut down and the condition corrected before the procedure is repeated.

6. When the pump is operating at full speed, open the discharge valve slowly. This should be done promptly after start-up to prevent damage to pump by operating at zero flow.
7. Adjust the flush line valves to produce the recommended pressure for the stuffing box.

OPTIONAL CHECKLIST

1. Driver/Pump Rotation: Check rotation each time the motor leads have been disconnected. Be sure that the driver operates in the direction indicated by the arrow on the pump casing. Rough operation and extreme vibration can result if the pump is operated in the wrong direction.
2. Flow: An accurate measurement of flow rate (volume/time) is difficult in the field. Venturi meters, flow nozzles, orifice plates, or timing the draw down in the wet well are all possible methods. Record any reading for future reference.
3. Pressure: Check and record both suction and discharge pressure gauge readings for future

reference. Also record voltage, amperage per phase, kilowatts if an indicating wattmeter is available, and pump speed.

4. Temperature: Check and record bearing temperatures using a thermometer. Temperature should not exceed 250°F.
5. Vibration: The acceptable vibration level of a centrifugal pump depends on the rigidity of the pump and the supporting structure. Refer to the Hydraulic Institute Standards for a complete description and charts on various pumps.
6. Sound: Field sound levels are difficult to measure because of background noise from piping, valves, drivers, gears, etc. Follow recommendations in the Hydraulic Institute Standards.
7. Make all pump output adjustments with the discharge valves.



CAUTION: Cavitation Damage Hazard

Do not throttle the suction valve to adjust the pump output.

Failure to follow these instructions could result in property damage and/or moderate personal injury.

FREEZE PROTECTION

Pumps that are shut down during freezing conditions should be protected by draining the pump and removing all liquid from the casing.

FIELD TESTS

A typical performance curve for a specific pump can be obtained from your local Bell & Gossett representative. This can be used in conjunction with a field test, if one is required. All Bell & Gossett tests and curves are based on the Hydraulic Institute Standards. Any field test must be conducted according to these Standards.

Unless otherwise specifically agreed, all capacity, head, and efficiencies are based on shop tests when handling clear, cold, fresh water at a temperature not over 85°F.

GENERAL MAINTENANCE AND PERIODIC INSPECTION

Operating conditions vary so widely that to recommend one schedule of preventative maintenance for all centrifugal pumps is not possible. Yet, some sort of regular inspection must be planned and followed. We suggest a permanent record be kept of the periodic inspections and maintenance performed on your pump. This recognition of maintenance procedures will keep your pump in good working condition, and prevent costly breakdowns.

One of the best rules to follow in the proper maintenance of your centrifugal pump is to keep a record of actual operating hours. Then, after a predetermined period of operation has elapsed, the pump should be given a thorough inspection. The length of this operating period will vary with different applications, and can only be determined from experience. New equipment, however, should be examined after a relatively short period of operation. The next inspection period can be lengthened somewhat. This system can be followed until a maximum period of operation is reached which should be considered the operating schedule between inspections.

LUBRICATION

Pump Bearings

Bearing housings are packed with grease at the factory and ordinarily will require no attention before starting, provided the pump has been stored in a clean, dry place prior to its first operation. The bearings should be watched for about an hour after the pump has been started to see that they are operating properly.

Periodic addition of grease is not required. If the bearing brackets are removed for maintenance reasons, thoroughly clean out the bearing housing and ensure that it is protected against dust and other contaminants.

Reassemble the pump using new bearings and lip seals. Use the grease fittings provided on the underside of the bearing brackets to fill the bearing cavities.

See the motor service instructions and nameplate for motor regreasing information. Pumps are to be regreased during pump reassembly using the grease types listed below or approved equal. After bearings are assembled on shaft wait until cool to hand pack bearings.

NOTICE:

Make sure the grease container, the greasing device, and the fittings are clean. Failure to do so can result in impurities entering the bearing housing when you regrease the bearings.

1. Wipe dirt from the grease fittings before greasing.
2. Fill both of the grease cavities through the fittings with the recommended grease. Stop when grease leaks out at shaft.
3. If needed, stop pump and wipe off excess grease.

Specifications – Grease Types

- Polyurea based greases:
1. ExxonMobile Polyrex™ EM
 2. Chevron SRI NLGI 2
 3. Shell Gadus® S5 T100 2

Polyurea based grease are the only recommended greases. Do not use other grease.



CAUTION: Bearing Failure

Do not mix different greases together as they will tend to separate and fail to properly lubricate the bearing.

Failure to follow these instructions could result in property damage and/or moderate personal injury.

Normally the maximum desirable operating temperature for ball bearings should not exceed 250°F. If the temperature of the bearing frame rises above the limit, the pump should be shut down to determine the cause. Check the temperature using an accurate measuring device to be sure.

Couplings

Polymer and elastomeric element type couplings are maintenance free and do not require lubrication. If other types of couplings are used, follow maintenance instructions of the coupling manufacturer.

SEAL INFORMATION

Mechanical Seals

Mechanical seals usually require no maintenance. To protect the seals, do not run the pump dry. Replace the seals if leakage is present.

Packing (Non-Asbestos)

Bell & Gossett does not advocate the use of asbestos packing material.

On packed pumps the packing is installed prior to shipment. Before pump is put into operation check the condition of packing. If the pump is installed within sixty (60) days after shipment, the packing will be in good condition with a sufficient supply of lubrication. If pump is stored for a longer period it may be necessary to repack the stuffing box. In all cases, however, we recommend an inspection of the packing before pump is started.

A soft, well-lubricated packing reduces stuffing box resistance and prevents excessive wear on the shaft sleeve. Standard packing may be purchased through you local Bell & Gossett representative.

When a pump with packing is first started it is advisable to have the packing slightly loose without causing an air leak. As the pump runs in, gradually tighten the gland bolts evenly. The gland should never be drawn to the point where packing is compressed too tightly and no leakage occurs. This will cause the packing to burn, score the shaft sleeve and prevent liquid from circulating through the stuffing box cooling the packing. The stuffing box is improperly packed or adjusted if friction in the box prevents turning the rotating element by hand. A properly operated stuffing box should run lukewarm with a slow drip of sealing liquid. After the pump has been in operation for some time, and the packing has been completely run-in, drippage from the stuffing box should be at least 40 to 60 drops per minute. This will indicate proper packing and shaft sleeve lubrication and cooling.

NOTE: Eccentric run-out of the shaft or sleeve through the packing could result in excess leakage. Correcting this defect is very important.

Packing should be checked frequently and replaced as service indicates; it is impossible to give any exact predictions. A packing tool should be used to remove all old packing from the stuffing box. Never reuse worn packing or merely add some new rings. Make sure the stuffing box is thoroughly cleaned before installing new packing. Also check the condition of the sleeve for possible wear. Make replacements where necessary.

New packing (non-asbestos) should be placed carefully into the stuffing box. If molded rings are used, the rings should be opened sideways and the joints pushed into the stuffing box first. The rings are installed one at a time, each ring seated firmly and the joints staggered at about a 90° rotation from each preceding joint.

If coil packing is used, cut one ring to accurate size with either a butt or mitered joint. An accurately cut butt joint is superior to a poor fitting mitered joint. Fit the ring over the sleeve to ensure proper length. Then remove and cut all other rings to the first sample. When the rings are placed around the sleeve a tight joint should be formed. Place the first ring in the bottom of the stuffing box. Then install each succeeding ring, staggering the joints as described above, making sure each ring is firmly seated.

Make sure the lantern ring is properly located in the stuffing box under the sealing water inlet. The function of the lantern ring is to establish a liquid seal around the shaft, prevent leakage of air through the stuffing box and lubricate the packing. If it is not properly located it serves no purpose.

MAINTENANCE OF FLOOD DAMAGED PUMPS



WARNING: Unexpected Startup Hazard

Disconnect and lockout power before servicing.

Failure to follow these instructions could result in serious personal injury or death, or property damage.



WARNING: Electrical Shock Hazard

Electrical connections to be made by a qualified electrician in accordance with all applicable codes, ordinances, and good practices.

Failure to follow these instructions could result in serious personal injury or death, or property damage.

Replace bearings and grease if the pump has been in a flooded condition. The motor should be evaluated by a qualified motor shop before being put back into service. Mechanical seals, stuff boxes, and their packing rings should be cleaned and inspected. Replace if needed. Couplings that require lubrication should be replaced.

TROUBLE SHOOTING

Between regular maintenance inspections, be alert for signs of motor or pump trouble. Common symptoms are listed below. Correct any trouble immediately and AVOID COSTLY REPAIR AND SHUTDOWN.

CAUSES	CURES
No Liquid Delivered	
1. Lack of prime 2. Loss of prime 3. Suction lift too high 4. Discharge head too high 5. Speed too low 6. Plugged suction diffuser or strainer screen 7. Impeller completely plugged	Fill pump and suction pipe completely with liquid. Check for leaks in suction pipe joints and fittings; vent casing to remove accumulated air. If no obstruction at inlet, check for pipe friction losses. However, static lift may be too great. Measure with mercury column or vacuum gauge while pump operates. If static lift is too high, liquid to be pumped must be raised or pump lowered. Check that valves are wide open. Check whether the properly wired. Frequency may be too low; motor may have an open phase. Verify that the driver and speed matches the pump nameplate speed. Dismantle and clean. Dismantle pump and clean impeller.
Not Enough Liquid Delivered	
8. Air leaks in suction piping 9. Speed too low 10. Discharge head too high 11. Suction lift too high 12. Impeller partially plugged 13. Cavitation; insufficient NPSH A (depending on installation) 14. Defective impeller 15. Wrong direction of rotation 16. Wrong direction of impeller 17. Too small impeller diameter (probable cause if none of the above) 18. Speed too low 19. Air leaks in suction piping	Test flanges for leakage by plugging inlet and putting line under pressure. A gauge will indicate a leak with a drop of pressure. See item 5. Check pipe friction losses. Large piping may correct condition. Check that valves are fully open. See item 3. See item 7. a. Increase positive suction head on pump. b. Reduce the temperature of the liquid in the suction pipe. Inspect impeller, bearings and shaft. Determine the cause and correct. Compare the rotation of the motor with the directional arrow on the pump casing. Correct as required. Reverse the impeller direction on the shaft. Check with the factory to see if a larger impeller can be used; otherwise, cut the pipe losses or increase the speed, or both as needed. Be careful not to overload the driver. See item 5. See item 8.

CAUSES	CURES
Not Enough Pressure	
20. Mechanical defects 21. Obstruction in liquid passages 22. Air or gases in liquid 23. Too small impeller diameter (Probable cause if none above)	See items 14 and 15. Dismantle pump and inspect passages of impeller and casing. Remove obstruction. Install an air removal device or repair leaks in system piping. See item 17.
24. Speed too low	See item 5.
25. Excessive system flow	Balance system.
Pump Operates For Short Time, Then Stops	
26. Incomplete priming 27. Suction lift too high 28. Air leaks in suction piping 29. Air or gases in liquid	Free pump, piping and valves of all air. If high points in suction line prevent this, they need correcting. See item 3. See item 8. See item 22.
Pump Takes Too Much Power	
30. Head lower than rating; thereby pumping too much liquid. 31. Cavitation 32. Mechanical defects. 33. Liquid heavier (in either viscosity or specific gravity) than allowed for. 34. Wrong direction of rotation. 35. Casing distorted by excessive strains from suction or discharge piping. 36. Shaft bent due to damage – through shipment, operation, or overhaul. 37. Mechanical failure of critical pump parts. 38. Misalignment. 39. Speed may be too high	Machine impeller's OD to size advised by factory. See item 13. See items 14 and 15. Use larger driver. Consult factory for recommended size. Test liquid for viscosity and specific gravity. See item 15. Check alignment. Examine pump for friction between impeller and casing. Replace damaged parts. Check deflection of rotor by turning on bearing journals. Total indicator run-out should not exceed 0.002" on shaft and 0.004" on impeller eye outer diameter. Check bearings and impeller for damage. Any irregularity in these parts will cause a drag on shaft. Realign pump and driver. Check frequency setting on the drive if equipped. Verify that the driver speed matches the pump nameplate speed.

GUARDS

ANSI/OSHA COUPLING GUARD REMOVAL/INSTALLATION



WARNING: Extreme Temperature Hazard

If pump, motor, or piping are operating at extremely high or low temperatures, guarding or insulation is required.

Failure to follow these instructions could result in serious personal injury or death, or property damage.

Removal

(See Figures 19 and 20.)

1. Remove the two capscrews and hardware that hold the outer guard's top and bottom halves together. Remove the top half of the outer guard.
2. Remove the two capscrews and hardware that hold the inner guard's top and bottom halves together. Remove the top half of the inner guard.
3. On some units, it may now be required to remove the coupling to gain access to the remaining guard hardware.
4. Remove the capscrews and hardware that fasten the guards to the guard support.
5. On units supplied with spacer couplings, a second guard support is supplied underneath the inner guard. If present, remove the two capscrews and hardware fastened to the second guard support.
6. Remove the capscrews and hardware that hold the guard support(s) to the base rail. Remove the guard support(s) and bottom guard halves.

Installation

(See Figures 19 and 20.)

1. Place the bottom inner guard into the bottom outer guard.
2. Hold the lower guards under the coupling and slide the guard support(s) between the base and lower guards.
3. Install the guard to the support hardware but do not tighten. Move the support(s) to the proper location on the base and install the hardware for support(s) to the base.
4. Slide the outer guard so it is within .25" from the motor face.
5. Slide the inner guard so it is within .25" from the pump bracket face.
6. Tighten the hardware.

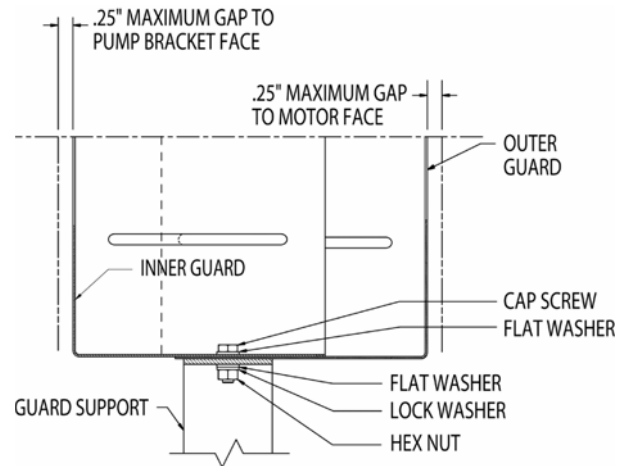

Figure 19: Coupling Guard

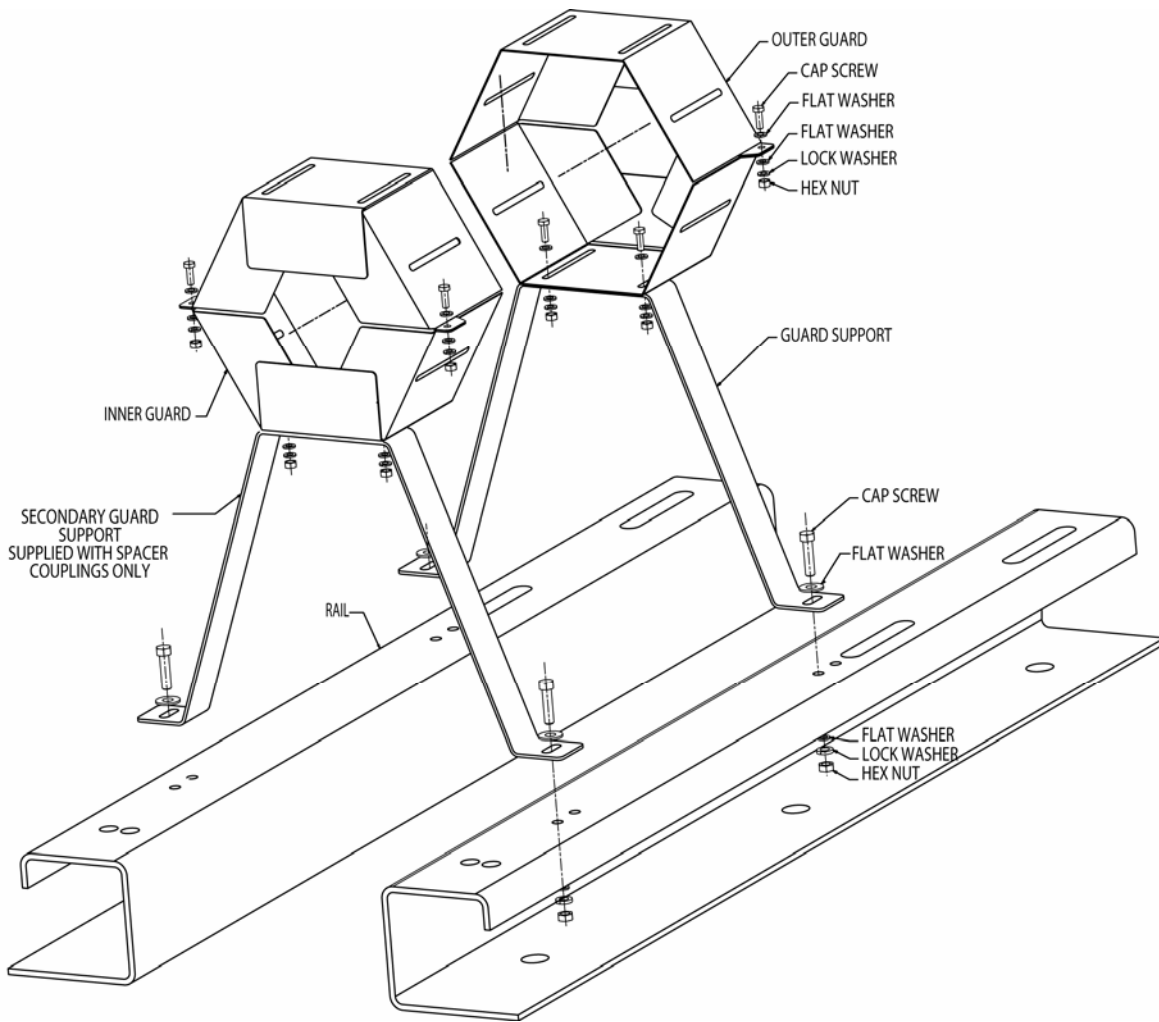

Figure 20: Installation/Removal Coupling Guard

BRACKET GUARDS

⚠ WARNING: Extreme Temperature Hazard

If pump, motor, or piping are operating at extremely high or low temperatures, guarding or insulation is required.

Failure to follow these instructions could result in serious personal injury or death, or property damage.

Guarding is also provided to give protection for the exposed shaft length between the seal gland/stuff box and the bearing housing. (See Figure 21.) Three guards are provided for each bracket: two for the side windows and one for the top window.

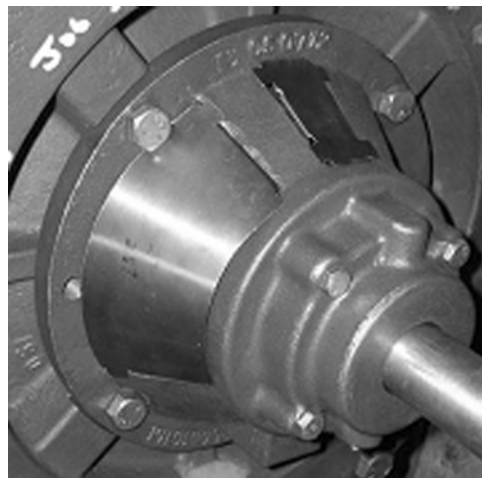
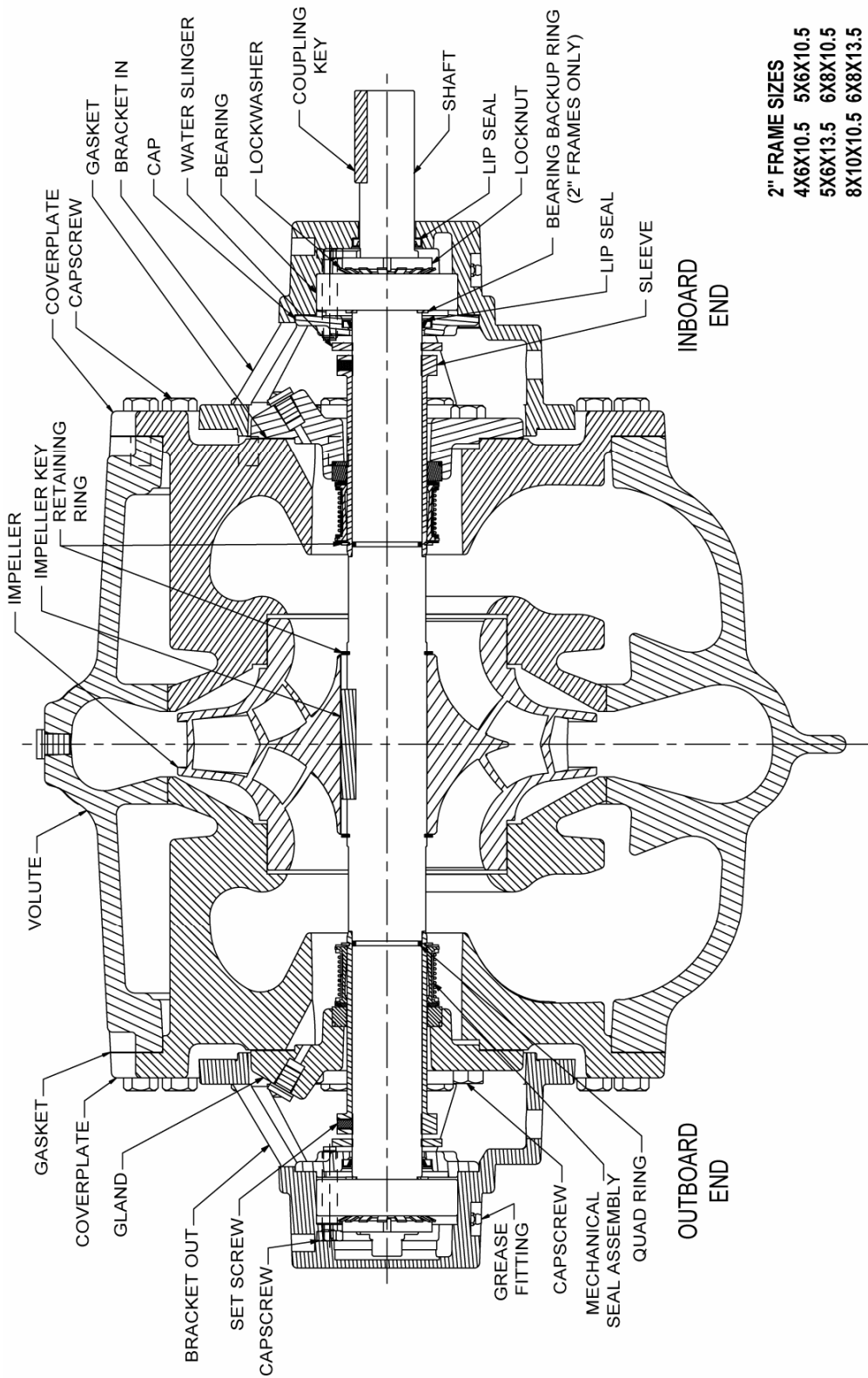

Figure 21: Bracket Guard Installed on Inboard Bearing Bracket

SERVICE



2" FRAME SIZES
 4X6X10.5 5X6X10.5
 5X6X13.5 6X8X10.5
 8X10X10.5 6X8X13.5

VSX ASSEMBLY CROSS SECTION
 STANDARD MECHANICAL SEAL

Figure 22: Mechanical View

GENERAL DISASSEMBLY PROCEDURES

SHUTDOWN

The following steps will address most normal shutdowns of the pump, such as maintenance. Make any further adjustments of process piping, valves, etc., as required.

1. Shut down the pump driver. (Consult manufacturer's instructions for special operations.)



WARNING: Unexpected Startup Hazard

Disconnect and lockout power before servicing.

Failure to follow these instructions could result in serious personal injury or death, or property damage.

2. Close the suction and discharge valves.
3. For pumps equipped with external flush, close the flush line valves. However, to prevent contaminating the packing, leave these lines open, unless the pump is completely drained.
4. Open the drain valves and casing vents as required.



CAUTION: Extreme Temperature Hazard

Allow pump temperatures to reach acceptable levels before proceeding. Open the drain valve. Do not proceed until liquid stops coming out of the drain valve. If liquid does not stop flowing from the drain valve, isolation valves are not sealing and should be repaired before proceeding. After liquid stops flowing from drain valve, leave the valve open and continue. Remove the drain plug located on the bottom of the pump housing. Do not reinstall the plug or close the drain valve until reassembly is completed.

Failure to follow these instructions could result in moderate personal injury or property damage.

DISASSEMBLY PROCEDURE TO REMOVE BEARING FRAMES – ALL PUMPS

1. Remove the coupling guard. See the **Guards** section.
2. Remove the capscrews that secure the coupling element to the hubs. Remove the coupling element. Depending on the type of coupling, proceed to step a or step b.
 - a. For non-spacer coupling assemblies: move the driver to allow sufficient access for

maintenance and remove the coupling hub on the pump.

- b. For spacer coupling assemblies: remove the coupling hub on the pump.

3. Remove the four capscrews from the bearing cap.
4. Remove the four bearing bracket capscrews.
5. Remove the bearing bracket using jacking screws. (See Figure 23.) Pry bars may also be used. (See Figure 24.)

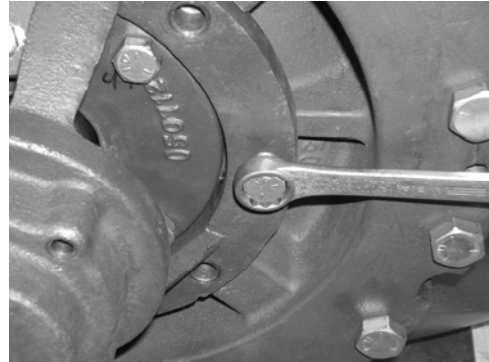

Figure 23: Removing the Outboard Bearing Bracket Using Jacking Screws

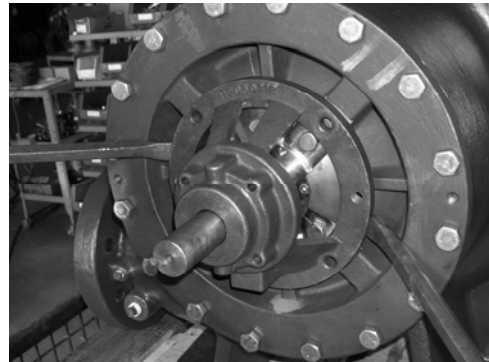

Figure 24: Removing the Inboard Bearing Bracket Using Pry Bars

6. Bend back the lockwasher tab and remove the locknut and lockwasher.
7. Remove the bearing with pullers. (See Figure 25.) A universal fixture kit (part number AC2394) may also be used. (See Figure 26.) The universal fixture kit should not be used on pumps with 2" frames as the bearing backup ring may damage the bearing cap's lip seal. (See Figure 27 for a listing of pump sizes with 2" frames.)

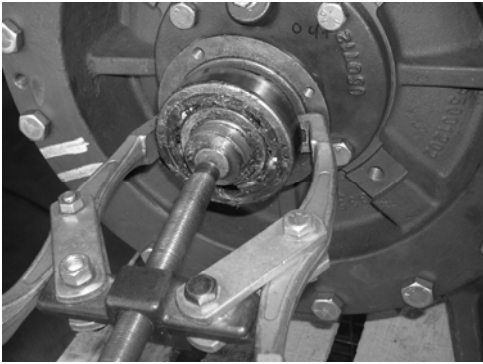

Figure 25: Removing the Bearing Using Pullers

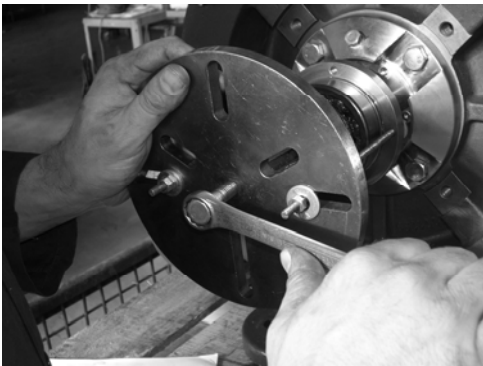

Figure 26: Removing the Bearing Using a Universal Kit

8. For 2" frames only: remove the bearing backup ring. (See Figure 27.) (See Figure 22 for a listing of pump sizes with 2" frames.)

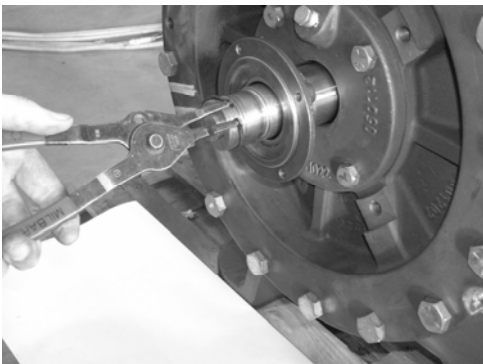

Figure 27: Removing the Bearing Backup Ring (2" Frames Only)

9. Remove the bearing cap from the shaft. Remove the slinger.
10. Repeat steps 1 through 9 to remove the bearing frame on the other side. When finished, proceed to the appropriate disassembly procedure depending on the type of seal in your pump.

11. Remove lip seals from both caps and the inboard bearing bracket.

DISASSEMBLY PROCEDURE TO REMOVE STANDARD MECHANICAL SEALS

1. Loosen the set screws in the sleeve.
2. Remove the four gland assembly capscrews.
3. Remove the gland assembly and the sleeve from the shaft. (See Figure 28.) The use of a bearing puller attached to the step in the sleeve may be required.



Figure 28: Removing the Gland Assembly and Sleeve

4. Remove the gland gasket.
5. While pushing down on the mechanical seal head, remove the retaining ring from the shaft sleeve groove. (See Figure 29.)



Figure 29: Mechanical Seal Head and Gland with Retaining Ring Removed

6. Remove the mechanical seal head from the sleeve assembly.
7. Remove the gland assembly from the shaft sleeve.
8. Remove the stationary mechanical seal seat from the gland bore.
9. Remove the quad ring from the shaft.

10. Repeat steps 1 through 9 for the other side.
11. If only the mechanical seals are to be replaced, proceed to the section entitled **Assembly Procedure to Install Standard Mechanical Seals.**

If disassembly of the pump is required, proceed to the section entitled **Disassembly Procedure to Remove Coverplates and Shaft Assembly – All Pumps.**

DISASSEMBLY PROCEDURE TO REMOVE STUFFING BOX AND PACKING.

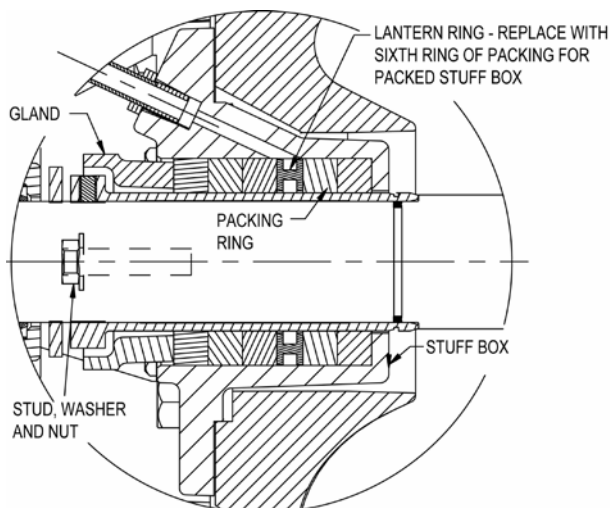

Figure 30: Flushed Stuffing Box Cross Section

1. Remove nuts, washers, studs, and glands.
2. Remove the packing rings and lantern ring.
3. Loosen the set screws in the sleeve and remove the sleeve from the shaft. The use of a bearing puller attached to the step in the sleeve may be required.
4. Remove the four stuffing box capscrews.
5. Remove the stuffing box.
6. Remove the stuffing box gasket.
7. Remove the quad ring from the shaft.
8. Repeat steps 1 through 7 for the other side.
9. If only the packing rings and sleeve are to be replaced, proceed to the section entitled **Assembly Procedure to Install Stuffing Box and Packing.**

If disassembly of the pump is required, proceed to the section entitled **Disassembly**

Procedure to Remove Coverplates and Shaft Assembly – All Pumps.

DISASSEMBLY PROCEDURE TO REMOVE CARTRIDGE SEALS

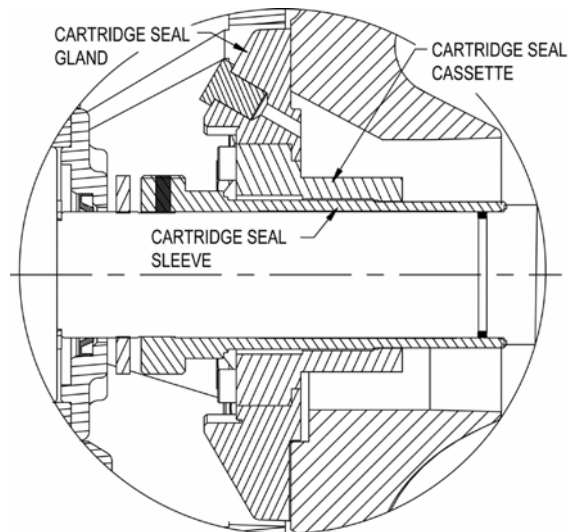

Figure 31: Cartridge Seal Cross Section

1. Loosen the set screws in the sleeve.
2. Remove the four cartridge seal capscrews.
3. Remove the cartridge seal from the shaft. (See Figure 32.)

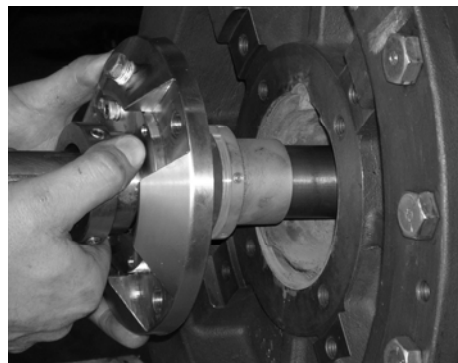

Figure 32: Removing the Cartridge Seal

4. Remove the cartridge seal gasket.
5. If only the cartridge seal's cassette is to be replaced, loosen the screws from the cassette/sleeve assembly and fit them to the threaded holes in the same part. Tighten evenly allowing the cassette to be pulled out from the gland and remove it from the shaft. (See Figure 33.)

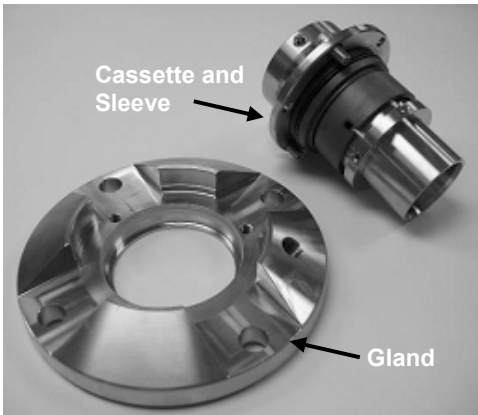

Figure 33: Cartridge Seal Gland and Service Kit (Cassett and Sleeve)

6. If only the cartridge seal or cartridge seal cassette is to be replaced, proceed to the section entitled **Assembly Procedure to Install Cartridge Seals**.
7. If disassembly of the pump is required, proceed to the section entitled **Disassembly Procedure to Remove Coverplates and Shaft Assembly – All Pumps**.



CAUTION: Equipment Damage

To prevent premature seal failure or possible injury, the unitized seals should not be used as an alternate or substitute for the balanced seals installed in a high suction pressure rated VSX pump.

Failure to follow these instructions could result in serious property damage and/or moderate personal injury.

DISASSEMBLY PROCEDURE TO REMOVE COVERPLATES AND SHAFT ASSEMBLY – ALL PUMPS

1. Ensure shaft threads are protected using tape or nuts. (See Figure 34.)
2. Remove the volute capscrews. Using jacking screws, pull the coverplate from the volute. (See Figure 34.)

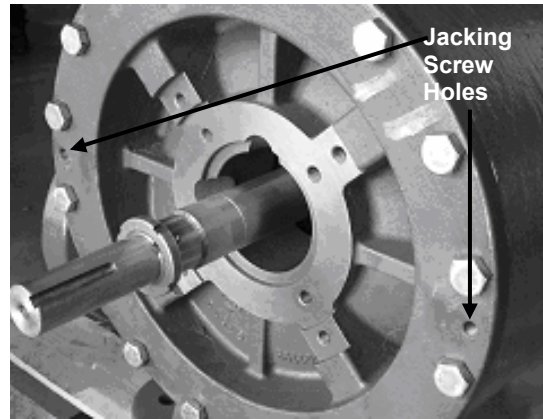

Figure 34: Removing the Coverplate Using Jacking Screws

3. Remove the volute gasket.
4. Pull the impeller and shaft assembly from the volute. (See Figure 35.)

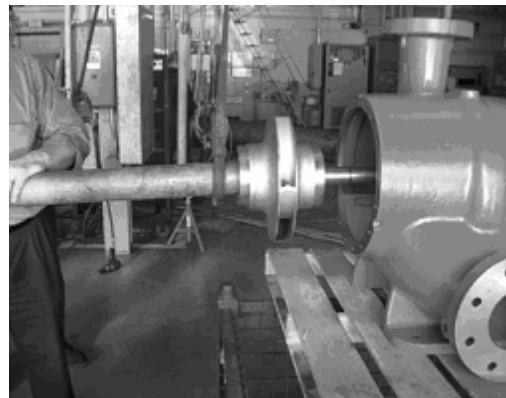

Figure 35: Removing the Shaft Assembly

5. Repeat steps 2 through 4 to remove the other coverplate.
6. Remove the impeller retaining rings.
7. The impeller is press fitted on the shaft. The use of a press is required for removing and mounting the impeller to the shaft.
8. Remove the impeller key from the shaft.

ASSEMBLY PROCEDURE TO INSTALL COVERPLATES AND SHAFT ASSEMBLY – ALL PUMPS

NOTE: Inspect all parts for wear and damage. Replace where needed.

1. Insert the impeller key into the shaft key slot.
2. Install the first impeller retaining ring. (See Figure 36.)

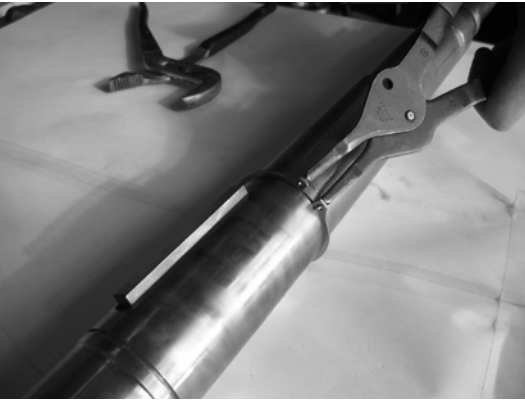

Figure 36: Installing the Impeller Retaining Ring

Refer to Figure 52 to check that the impeller, shaft, and volute are orientated correctly for the required rotation before proceeding.

3. Press the impeller with a suitable press onto the shaft.
4. Install the second impeller retaining ring.
5. Lubricate the quad rings with P-80^{®3} Rubber Lubricant Emulsion, soapy water, or equivalent and slide them over the shaft ends for installation in the quad ring grooves. (See Figure 37.)



Figure 37: Installing the Quad Rings

6. Slide the volute gasket onto the coverplate. (See Figure 38.) Grease may be used to hold the gasket in place.



Figure 38: Installing the Gasket on the Coverplate

7. Using guide pins (threaded rod or a headless bolt) threaded into the volute, install coverplate. One coverplate has one notch (See Figure 39.), and the other coverplate has two notches (See Figure 40.). Ensure the coverplate notches are aligned to the notches in the volute.

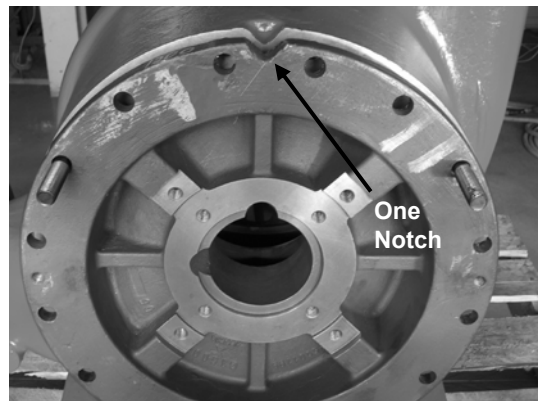
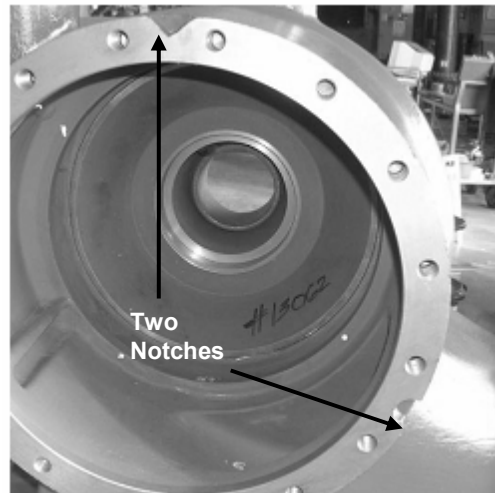

Figure 39: Installing the Coverplate Using the Guide Rods



³ P-80 is a registered trademark of International Products Corp.

Figure 40: View of the pump interior after one coverplate has been installed

8. Install the volute capscrews.

NOTE: Refer to Table 6 for all capscrew torque requirements.

9. Insert the shaft assembly into the volute. (See Figure 41.) Ensure that the shaft threads are protected using tape or nuts. (See Figure 34.)

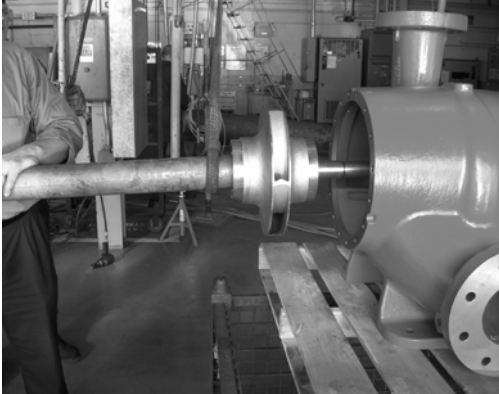

Figure 41: Installing the Shaft Assembly

10. Repeat steps 6 through 8 to install the second coverplate.

ASSEMBLY PROCEDURE TO INSTALL STANDARD MECHANICAL SEALS

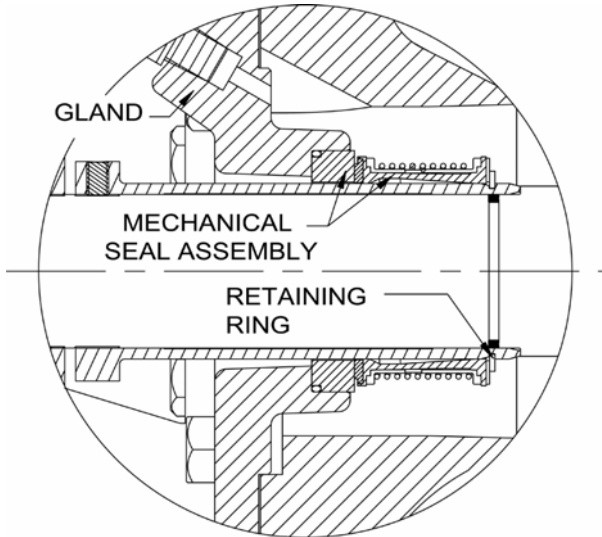

Figure 42: Standard Mechanical Seal Cross Section

1. Press the stationary mechanical seal seat into the gland bore. (See Figure 43.) To ease assembly, lightly lubricate the bore with P-80 Rubber Lubricant Emulsion, soapy water, or equivalent.

NOTE: Handle the seals with care. Clean the glands and seals before assembly. Take care not to damage the seals during assembly.

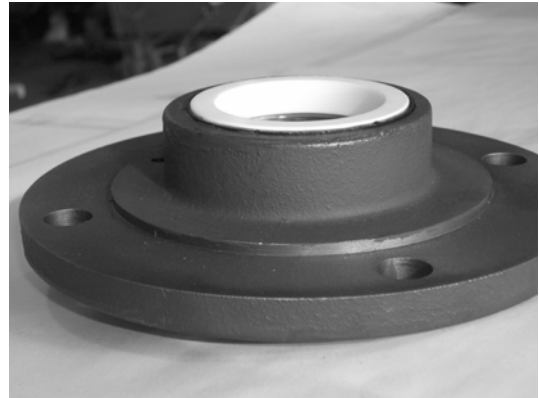

Figure 43: The Seal Seat Installed in the Gland

2. Slide the gland assembly over the shaft sleeve.
3. Lightly lubricate the shaft sleeve with P-80 Rubber Lubricant Emulsion, soapy water, or equivalent and slide the mechanical seal head onto the sleeve.
4. While pushing down on the mechanical seal head, install the retaining ring into the shaft sleeve groove.
5. Apply anti-seize compound only to the area of the shaft that will be under the sleeve. (See Figure 44.)

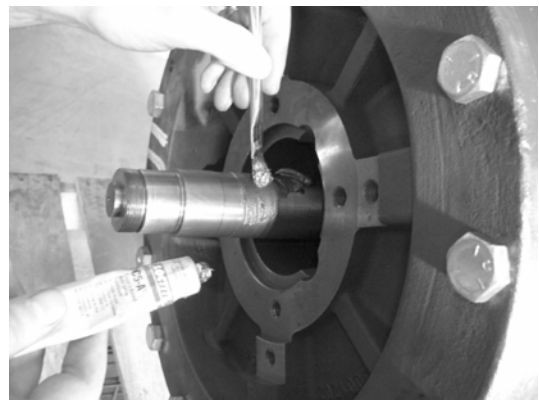

Figure 44: Applying Anti-seize Compound to the Shaft

6. Place the gland gasket onto the gland. Grease may be used to hold the gasket in place. Slide the complete assembly over the shaft until the sleeve bottoms out onto the shaft locating shoulder. (See Figure 45.)

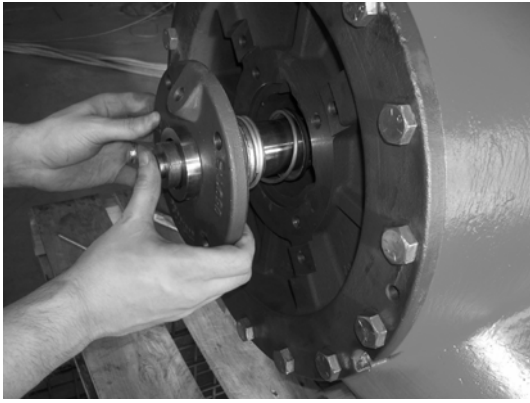

Figure 45: Installing the Gland Assembly

7. Install the four gland assembly capscrews.
8. Install the set screws in the sleeve and tighten to 50 inch-lbs.
9. Install the slinger.
10. Repeat steps 1 through 9 to install the seal on the other side. When finished, see the section entitled **Assembly Procedure to Install Bearing Frames – All Pumps**.

ASSEMBLY PROCEDURE TO INSTALL STUFFING BOX AND PACKING

1. Place stuffing box, wetted end down, onto the bench and slide the sleeve through stuffing box bore letting it set onto bench
2. Install packing rings over the sleeve and down into the bore so that the ends butt, leaving no gap between the packing and stuffing box. Press the packing to the bottom of the stuffing box. Stagger the joints of each packing ring at least 90°.

NOTE: On a flushed stuffing box, the lantern ring will replace the third packing ring from the bottom, requiring only five rings of packing per side. (See Figure 30.) The lantern ring must be aligned with the seal water inlet when the packing is compressed. On non-flushed (plugged) stuffing boxes, a sixth ring of packing is supplied for each side and takes the place of the lantern ring.

3. Apply anti-seize compound only to the area of the shaft that will be under the sleeve.
4. Place the stuffing box gasket on the stuffing box. Grease may be used to hold the gasket in place.
5. Slide the sleeve/stuffing box subassembly over the shaft until the sleeve bottoms out onto the shaft locating shoulder.

6. Install the four stuffing box capscrews.
7. Install set screws in the sleeve and tighten to 50 inch-lbs.

NOTE: The last ring in each box may not be required until after the pump has operated for a period of time.

8. Assemble the glands, studs, washers, and nuts square with the stuffing box and pull up tight. (See Figure 46 of an exploded assembly.)

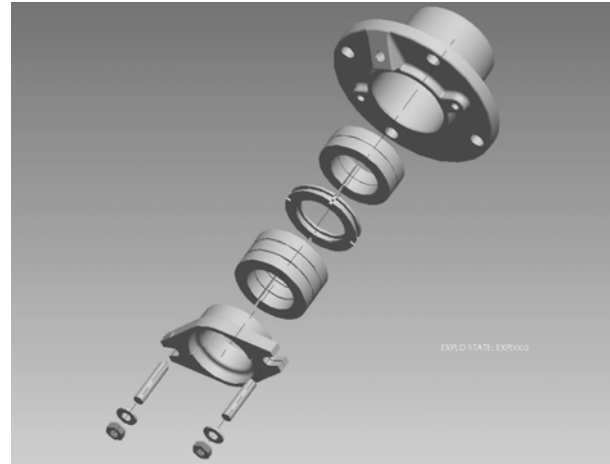

Figure 46: Exploded View of Stuffing Box with Lantern Ring

9. Repeat steps 1 through 8 for the other side. When finished, see the section entitled **Assembly Procedure to Install Bearing Frames – All Pumps**.

NOTE: After the bearing frame has been installed, loosen the nuts to permit the packing to expand. Retighten until finger tight. Final adjustment of the gland nuts must be done while the pump is running. Allow approximately 30 minutes between adjustments. A good adjustment should allow approximately one drip per second.

ASSEMBLY PROCEDURE TO INSTALL CARTRIDGE SEALS

1. Apply anti-seize compound only to the area of the shaft that will be under the sleeve.
2. If installing an entire cartridge seal, place the gasket onto the gland of the cartridge seal. (See Figure 47.) Grease may be used to hold the gasket in place. Slide the complete assembly over the shaft until the gland fully seats into the coverplate bore. Install and tighten the four cartridge seal capscrews. Push the sleeve fully home to axial stop and tighten set screws to 130 inch-lbs.

If installing a cartridge seal cassette, use P-80 Rubber Lubricant Emulsion, soapy water, or equivalent to lubricate the static face o-ring. Slide the cassette onto the shaft ensuring the seal faces properly enter the cavity. Lightly tighten the cassette to the gland with capscrews. Finish torque to 170 inch-lbs. Push the sleeve fully home to axial stop and tighten set screws to 130 inch-lbs.

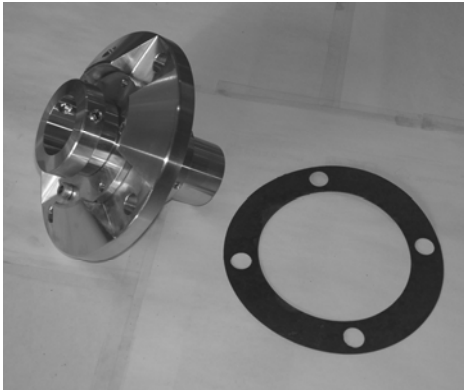

Figure 47: Cartridge Seal and Gasket

- Repeat steps 1 and 2 for the other side. When finished, see the section entitled **Assembly Procedure to Install Bearing Frames – All Pumps**.

ASSEMBLY PROCEDURE TO INSTALL BEARING FRAMES – ALL PUMPS

- Install the lip seal into the bearing cap bore. The lip seal should sit against the bottom of the machined bore. The lip should face away from the bearing cavity. Install the bearing cap onto the shaft. (See Figure 46.)



Figure 48: Bearing Cap and Lip Seal

- For 2"-frame pumps only, install a bearing backup ring onto the shaft. (See Figure 49.) (See Figure 22 for a listing of pump sizes with 2" frames.)

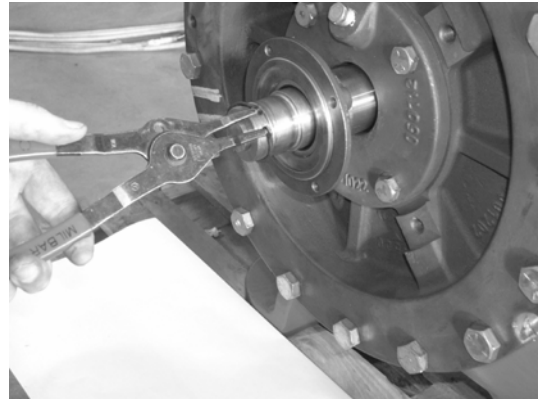

Figure 49: Installing the Bearing Backup Ring (2" Frame Pumps Only)

- Heat the bearing using an induction heater.

CAUTION Bearing Damage

Do not exceed a temperature of 275°F when heating the bearing. Damage to the bearing components may result if 275 F is exceeded.

Failure to follow these instructions could result in property damage and/or moderate personal injury.

CAUTION Extreme Temperature Hazard

Bearing surfaces are hot. Use appropriate protection to prevent burns.

Failure to follow these instructions could result in property damage and/or moderate personal injury.

- Using gloves, slide the heated bearing onto the shaft against the shaft shoulder. For 2" frame pumps, slide the heated bearing onto the shaft against the backup ring.

NOTE: The bearings are single shielded and the shield should face inward toward the impeller.

- Install a lockwasher and locknut onto the shaft. Tighten using a spanner wrench or hammer and punch. Make sure the locknut is secured and then bend over the tabs on the lockwasher. (See Figure 50.)



Figure 50: Installing the Lockwasher and Locknut

6. For inboard bearing bracket only:

Install the lip seal into the bearing bracket bore. The lip seal should sit against the bottom of the machined bore. The lip should face away from the bearing cavity. (See Figure 51.)



Figure 51: Bearing Bracket and Lip Seal

7. Coat the inside of the bearing bracket bore with grease and slide it into place over the bearing. Install four capscrews to secure the bracket to the coverplate.

8. Fasten the bearing cap to the bearing bracket with four capscrews.
9. Using grease fitting at the bottom of the bracket, fill the bearing cavity until grease is seen coming out from the lip seal(s).

NOTE: Use only Polyurea based grease.

10. Repeat steps 1 through 9 to assemble the other bearing frame.

NOTE: Only the inboard bearing bracket has a lip seal.

GENERAL ASSEMBLY INSTRUCTIONS

1. Install the flush kit, and if required, reinstall the drain plugs, and close the drain valve.
2. Install and align the coupling, following the instructions in the **Coupling Alignment** section.
3. Install the coupling guard and bracket guards. (See the **Guards** section.)
4. Open the isolation valves and check the pumps for leaks. If no leaks are present, return the pump to service. (See the **Operation** section.)

TO CHANGE ROTATION

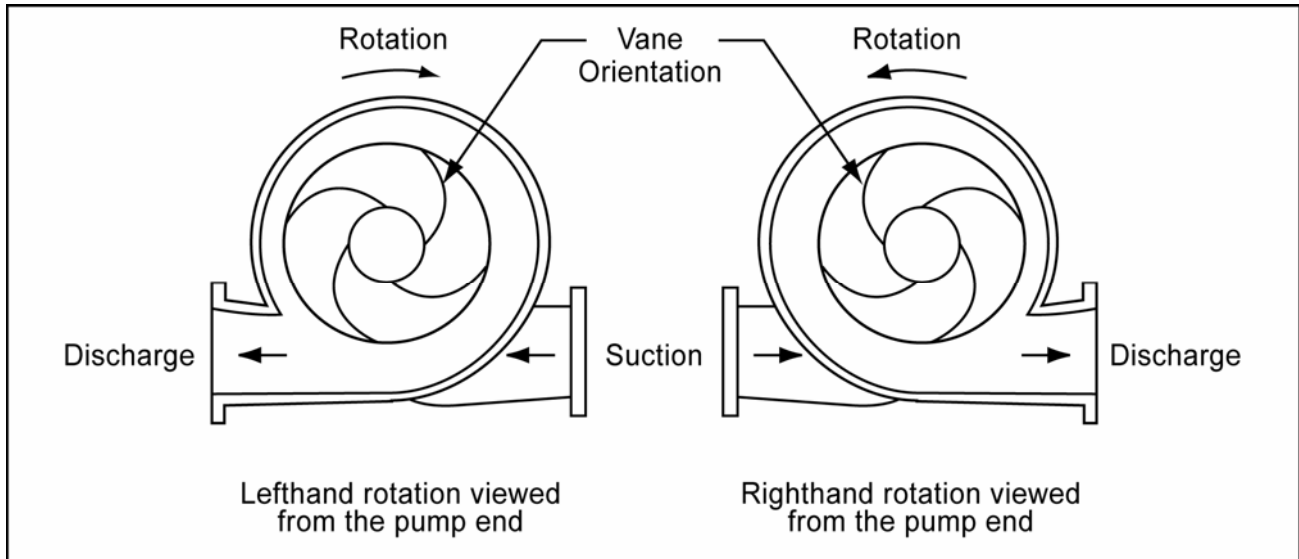

Figure 52: Impeller to Volute Orientation

⚠ WARNING: Unexpected Startup Hazard

Disconnect and lockout power before servicing.

Failure to follow these instructions could result in serious personal injury or death, or property damage.

⚠ WARNING: Electrical Shock Hazard

Electrical connections to be made by a qualified electrician in accordance with all applicable codes, ordinances, and good practices.

Failure to follow these instructions could result in serious personal injury or death, or property damage.

⚠ WARNING: Rotating Components Hazard

Do not operate pump without all guards in place.

Failure to follow these instructions could result in serious personal injury or death and property damage.

1. Remove the pump from the base.
2. Follow the Disassembly Procedures applicable to the pump.

NOTE: Only one of the coverplates must be removed to change rotation.

3. Press the (press-fitted) impeller off the shaft. Observe the direction in which the vane tips are pointing. Turn the impeller end for end (180°) and press it back onto the shaft. Refer to the section entitled **Assembly Procedure to Install Coverplates and Shaft Assembly**. The vane tips should be pointing in the opposite direction. (See Figure 52.)
4. Reinstall the rotating assembly per the section entitled **Assembly Procedure to Install Coverplates and Shaft Assembly**. Check the impeller to volute relationship per Figure 52.
5. Complete the reassembly by following the procedures applicable to the pump.

NOTE: Unless the motor rotation is reversed the impeller will run backward. Check the motor for proper rotation before putting the pump back in service.

TO CHANGE STANDARD MECHANICAL SEALS

See the following sections:

- A. GENERAL DISASSEMBLY INSTRUCTIONS
- B. DISASSEMBLY PROCEDURE TO REMOVE BEARING FRAMES – ALL PUMPS
- C. DISASSEMBLY PROCEDURE TO REMOVE STANDARD MECHANICAL SEALS
- D. ASSEMBLY PROCEDURE TO INSTALL STANDARD MECHANICAL SEALS
- E. ASSEMBLY PROCEDURE TO INSTALL BEARING FRAMES – ALL PUMPS
- F. GENERAL ASSEMBLY INSTRUCTIONS

TO CHANGE CARTRIDGE SEALS

See the following sections:

- A. GENERAL DISASSEMBLY INSTRUCTIONS
- B. DISASSEMBLY PROCEDURE TO REMOVE BEARING FRAMES – ALL PUMPS
- C. DISASSEMBLY PROCEDURE TO REMOVE CARTRIDGE SEALS
- D. ASSEMBLY PROCEDURE TO INSTALL CARTRIDGE SEALS
- E. ASSEMBLY PROCEDURE TO INSTALL BEARING FRAMES – ALL PUMPS
- F. GENERAL ASSEMBLY INSTRUCTIONS

TO CHANGE THE PACKING OR SLEEVE

See the following sections:

- A. GENERAL DISASSEMBLY INSTRUCTIONS
- B. DISASSEMBLY PROCEDURE TO REMOVE STUFFING BOX AND PACKING
- C. ASSEMBLY PROCEDURE TO INSTALL STUFFING BOX AND PACKING
- D. ASSEMBLY PROCEDURE TO INSTALL BEARING FRAMES – ALL PUMPS
- E. GENERAL ASSEMBLY INSTRUCTIONS

ORDERING PARTS

The pumps covered by this manual have been designed and built with certain replaceable wearing parts. The recommended inventory of spare parts depends upon the installation and the importance of continued operation.

For normal service, with repairs to be made in the field, the following parts are recommended for stock.

- 1 set of bearings
- 1 set of wearing rings (if required)
- 1 set of casing gaskets, quad rings and lip seals
- 2 mechanical seals (complete)

Parts should be ordered as far in advance of their use as possible since circumstances beyond the control of the company may reduce existing stock. Not all parts are stocked and must be manufactured for each order.

To facilitate rapid handling of your order for spare parts, be sure to include the following information:



1. Serial number of the pump. (See the pump nameplate.)
2. Name of the part.
3. Quantity of each part.
4. Material desired. (Parts will be furnished in original materials unless specified as a material change. All material substitutions should be discussed with the factory.)

DEALER SERVICING

If trouble occurs that cannot be rectified, contact your local Bell & Gossett representative. The representative will need the following information in order to provide assistance:

1. Complete nameplate data of the pump and motor.
2. Suction and discharge pipe pressure gauge readings.
3. Ampere draw of the motor.
4. A sketch of the pumping hook-up and piping.

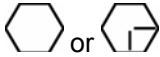
Table 6: Capscrew Torque

Capscrew Type	Head Marking	Capscrew Torque (Foot-Pound)								
		Capscrew Diameter								
		1/4	5/16	3/8	7/16	1/2	5/8	3/4	7/8	1
SAE Grade 2		6	13	25	38	60	120	190	210	300
Brass Stainless Steel		4	10	17	27	42	83	130	200	300
SAE Grade 5		10	20	35	60	90	180	325	525	800
SAE Grade 8		13	28	46	75	115	225	370	590	895

COMMERCIAL WARRANTY

Warranty. For goods sold to commercial buyers, Seller warrants the goods sold to Buyer hereunder (with the exception of membranes, seals, gaskets, elastomer materials, coatings and other "wear parts" or consumables all of which are not warranted except as otherwise provided in the quotation or sales form) will be (i) be built in accordance with the specifications referred to in the quotation or sales form, if such specifications are expressly made a part of this Agreement, and (ii) free from defects in material and workmanship for a period of one (1) year from the date of installation or eighteen (18) months from the date of shipment (which date of shipment shall not be greater than thirty (30) days after receipt of notice that the goods are ready to ship), whichever shall occur first, unless a longer period is specified in the product documentation (the "Warranty").

Except as otherwise required by law, Seller shall, at its option and at no cost to Buyer, either repair or replace any product which fails to conform with the Warranty provided Buyer gives written notice to Seller of any defects in material or workmanship within ten (10) days of the date when any defects or non-conformance are first manifest. Under either repair or replacement option, Seller shall not be obligated to remove or pay for the removal of the defective product or install or pay for the installation of the replaced or repaired product and Buyer shall be responsible for all other costs, including, but not limited to, service costs, shipping fees and expenses. Seller shall have sole discretion as to the method or means of repair or replacement. Buyer's failure to comply with Seller's repair or replacement directions shall terminate Seller's obligations under this Warranty and render the Warranty void. Any parts repaired or replaced under the Warranty are warranted only for the balance of the warranty period on the parts that were repaired or replaced. Seller shall have no warranty obligations to Buyer with respect to any product or parts of a product that have been: (a) repaired by third parties other than Seller or without Seller's written approval; (b) subject to misuse, misapplication, neglect, alteration, accident, or physical damage; (c) used in a manner contrary to Seller's instructions for installation, operation and maintenance; (d) damaged from ordinary wear and tear, corrosion, or chemical attack; (e) damaged due to abnormal conditions, vibration, failure to properly prime, or operation without flow; (f) damaged due to a defective power supply or improper electrical protection; or (g) damaged resulting from the use of accessory equipment not sold or approved by Seller. In any case of products not manufactured by Seller, there is no warranty from Seller; however, Seller will extend to Buyer any warranty received from Seller's supplier of such products.

THE FOREGOING WARRANTY IS EXCLUSIVE AND IN LIEU OF ANY AND ALL OTHER EXPRESS OR IMPLIED WARRANTIES, GUARANTEES, CONDITIONS OR TERMS OF WHATEVER NATURE RELATING TO THE GOODS PROVIDED HEREUNDER, INCLUDING WITHOUT LIMITATION ANY IMPLIED WARRANTIES OF MERCHANTABILITY AND FITNESS FOR A PARTICULAR PURPOSE, WHICH ARE HEREBY EXPRESSLY DISCLAIMED AND EXCLUDED. EXCEPT AS OTHERWISE REQUIRED BY LAW, BUYER'S EXCLUSIVE REMEDY AND SELLER'S AGGREGATE LIABILITY FOR BREACH OF ANY OF THE FOREGOING WARRANTIES ARE LIMITED TO REPAIRING OR REPLACING THE PRODUCT AND SHALL IN ALL CASES BE LIMITED TO THE AMOUNT PAID BY THE BUYER FOR THE DEFECTIVE PRODUCT. IN NO EVENT SHALL SELLER BE LIABLE FOR ANY OTHER FORM OF DAMAGES, WHETHER DIRECT, INDIRECT, LIQUIDATED, INCIDENTAL, CONSEQUENTIAL, PUNITIVE, EXEMPLARY OR SPECIAL DAMAGES, INCLUDING BUT NOT LIMITED TO LOSS OF PROFIT, LOSS OF ANTICIPATED SAVINGS OR REVENUE, LOSS OF INCOME, LOSS OF BUSINESS, LOSS OF PRODUCTION, LOSS OF OPPORTUNITY OR LOSS OF REPUTATION.

LIMITED CONSUMER WARRANTY

Warranty. For goods sold for personal, family or household purposes, Seller warrants the goods purchased hereunder (with the exception of membranes, seals, gaskets, elastomer materials, coatings and other "wear parts" or consumables all of which are not warranted except as otherwise provided in the quotation or sales form) will be free from defects in material and workmanship for a period of one (1) year from the date of installation or eighteen (18) months from the product date code, whichever shall occur first, unless a longer period is provided by law or is specified in the product documentation (the "Warranty").

Except as otherwise required by law, Seller shall, at its option and at no cost to Buyer, either repair or replace any product which fails to conform with the Warranty provided Buyer gives written notice to Seller of any defects in material or workmanship within ten (10) days of the date when any defects or non-conformance are first manifest. Under either repair or replacement option, Seller shall not be obligated to remove or pay for the removal of the defective product or install or pay for the installation of the replaced or repaired product and Buyer shall be responsible for all other costs, including, but not limited to, service costs, shipping fees and expenses. Seller shall have sole discretion as to the method or means of repair or replacement. Buyer's failure to comply with Seller's repair or replacement directions shall terminate Seller's obligations under this Warranty and render this Warranty void. Any parts repaired or replaced under the Warranty are warranted only for the balance of the warranty period on the parts that were repaired or replaced. The Warranty is conditioned on Buyer giving written notice to Seller of any defects in material or workmanship of warranted goods within ten (10) days of the date when any defects are first manifest.

Seller shall have no warranty obligations to Buyer with respect to any product or parts of a product that have been: (a) repaired by third parties other than Seller or without Seller's written approval; (b) subject to misuse, misapplication, neglect, alteration, accident, or physical damage; (c) used in a manner contrary to Seller's instructions for installation, operation and maintenance; (d) damaged from ordinary wear and tear, corrosion, or chemical attack; (e) damaged due to abnormal conditions, vibration, failure to properly prime, or operation without flow; (f) damaged due to a defective power supply or improper electrical protection; or (g) damaged resulting from the use of accessory equipment not sold or approved by Seller. In any case of products not manufactured by Seller, there is no warranty from Seller; however, Seller will extend to Buyer any warranty received from Seller's supplier of such products.

THE FOREGOING WARRANTY IS PROVIDED IN PLACE OF ALL OTHER EXPRESS WARRANTIES. ALL IMPLIED WARRANTIES, INCLUDING BUT NOT LIMITED TO THE IMPLIED WARRANTIES OF MERCHANTABILITY AND FITNESS FOR A PARTICULAR PURPOSE, ARE LIMITED TO ONE (1) YEAR FROM THE DATE OF INSTALLATION OR EIGHTEEN (18) MONTHS FROM THE PRODUCT DATE CODE, WHICHEVER SHALL OCCUR FIRST. EXCEPT AS OTHERWISE REQUIRED BY LAW, BUYER'S EXCLUSIVE REMEDY AND SELLER'S AGGREGATE LIABILITY FOR BREACH OF ANY OF THE FOREGOING WARRANTIES ARE LIMITED TO REPAIRING OR REPLACING THE PRODUCT AND SHALL IN ALL CASES BE LIMITED TO THE AMOUNT PAID BY THE BUYER FOR THE DEFECTIVE PRODUCT. IN NO EVENT SHALL SELLER BE LIABLE FOR ANY OTHER FORM OF DAMAGES, WHETHER DIRECT, INDIRECT, LIQUIDATED, INCIDENTAL, CONSEQUENTIAL, PUNITIVE, EXEMPLARY OR SPECIAL DAMAGES, INCLUDING BUT NOT LIMITED TO LOSS OF PROFIT, LOSS OF ANTICIPATED SAVINGS OR REVENUE, LOSS OF INCOME, LOSS OF BUSINESS, LOSS OF PRODUCTION, LOSS OF OPPORTUNITY OR LOSS OF REPUTATION.

Some states do not allow limitations on how long an implied warranty lasts, so the above limitation may not apply to you. Some states do not allow the exclusion or limitation of incidental or consequential damages, so the above exclusions may not apply to you. This warranty gives you specific legal rights, and you may also have other rights which may vary from state to state.

To make a warranty claim, check first with the dealer from whom you purchased the product or visit www.xyleminc.com for the name and location of the nearest dealer providing warranty service.

NOTES

Xylem |'zīləm|

- 1) The tissue in plants that brings water upward from the roots;
- 2) a leading global water technology company.

We're a global team unified in a common purpose: creating advanced technology solutions to the world's water challenges. Developing new technologies that will improve the way water is used, conserved, and re-used in the future is central to our work. Our products and services move, treat, analyze, monitor and return water to the environment, in public utility, industrial, residential and commercial building services settings. Xylem also provides a leading portfolio of smart metering, network technologies and advanced analytics solutions for water, electric and gas utilities. In more than 150 countries, we have strong, long-standing relationships with customers who know us for our powerful combination of leading product brands and applications expertise with a strong focus on developing comprehensive, sustainable solutions.

For more information on how Xylem can help you, go to www.xylem.com



Xylem Inc.
8200 N. Austin Avenue
Morton Grove, IL 60053
Phone: (847) 966-3700
Fax: (847) 965-8379
www.xylem.com/bellgossett

Bell & Gossett is a trademark of Xylem Inc. or one of its subsidiaries.
© 2019 Xylem Inc. P5002169E February 2019