



installation, start-up, and operating instructions

DELUXE 4-WAY MULTIPOISE FIXED-CAPACITY DIRECT-VENT CONDENSING GAS FURNACE

350MAV Series F

Cancels: II 350M-40-12 II 350M-40-13
9-01



A93040



REGISTERED QUALITY SYSTEM

NOTE: Read the entire instruction manual before starting the installation.

This symbol → indicates a change since the last issue.

TABLE OF CONTENTS

| | |
|---|---|
| SAFETY CONSIDERATIONS | 2 |
| INTRODUCTION | 2 |
| CODES AND STANDARDS | 4 |
| ELECTROSTATIC DISCHARGE (ESD) PRECAUTIONS..... | 5 |
| APPLICATIONS..... | 5 |
| General | 5 |
| Upflow Applications..... | 5 |
| Condensate Trap Location (Factory-Shipped Orientation)..... | 5 |
| Condensate Trap Tubing (Factory-Shipped Orientation)..... | 6 |
| Condensate Trap Location (Alternate Upflow Orientation)..... | 6 |
| Condensate Trap Tubing (Alternate Upflow Orientation)..... | 7 |
| Condensate Trap Field Drain Attachment..... | 7 |
| Pressure Switch Tubing..... | 7 |
| Upper Collector Box and Inducer Housing (Unused) Drain Connections..... | 7 |

| | |
|--|----|
| Condensate Trap Freeze Protection | 7 |
| Downflow Applications..... | 7 |
| Condensate Trap Location | 7 |
| Condensate Trap Tubing | 7 |
| Condensate Trap Field Drain Attachment..... | 8 |
| Pressure Switch Tubing..... | 8 |
| Condensate Trap Freeze Protection | 8 |
| Horizontal Left (Supply-Air Discharge) Applications | 8 |
| Condensate Trap Location | 9 |
| Condensate Trap Tubing | 9 |
| Condensate Trap Field Drain Attachments | 9 |
| Pressure Switch Tubing..... | 10 |
| Condensate Trap Freeze Protection | 10 |
| Construct a Working Platform..... | 10 |
| Horizontal Right (Supply-Air Discharge) Applications | 10 |
| Condensate Trap Location | 11 |
| Condensate Trap Tubing | 11 |
| Condensate Trap Field Drain Attachment..... | 11 |
| Pressure Switch Tubing..... | 11 |
| Condensate Trap Freeze Protection | 12 |
| Construct a Working Platform..... | 12 |
| LOCATION..... | 12 |
| General | 12 |
| Furnace Location Relative to Cooling Equipment | 13 |
| Hazardous Locations..... | 13 |
| INSTALLATION | 13 |
| Leveling Legs (If Desired)..... | 13 |
| Installation in Upflow and Downflow Applications | 14 |
| Installation in Horizontal Applications | 15 |
| Air Ducts..... | 15 |
| General Requirements | 15 |
| Ductwork Acoustical Treatment | 15 |
| Supply Air Connections | 16 |
| Return Air Connections..... | 16 |
| Filter Arrangement..... | 16 |
| Bottom Closure Panel..... | 17 |
| Gas Piping..... | 17 |
| Electrical Connections | 18 |
| 115-v Wiring..... | 18 |
| 24-v Wiring..... | 20 |
| Accessories | 20 |
| Direct Venting..... | 20 |
| Removal of Existing Furnaces from Common Vent systems | 20 |
| Combustion-Air and Vent Piping | 20 |
| Concentric Vent and Combustion-Air Termination Kit Installation..... | 28 |
| Multiventing and Vent Terminations..... | 30 |
| Condensate Drain..... | 31 |
| General..... | 31 |
| Application..... | 31 |
| Condensation Drain Protection | 33 |
| Sequence of Operation..... | 33 |
| Heating Mode | 33 |

| | |
|--|----|
| Cooling Mode | 33 |
| Continuous Blower Mode | 34 |
| Heat Pump Mode..... | 34 |
| Component Test..... | 34 |
| START-UP PROCEDURES..... | 35 |
| General | 35 |
| Prime Condensate Trap With Water..... | 35 |
| Purge Gas Lines..... | 35 |
| Adjustments..... | 35 |
| Set Gas Input Rate | 35 |
| Set Temperature Rise | 42 |
| Adjust Blower Off Delay (Heat Mode)..... | 43 |
| Set Thermostat Heat Anticipator | 43 |
| Check Safety Controls..... | 43 |
| Check Primary Limit Control | 43 |
| Check Pressure Switch..... | 43 |
| Checklist..... | 43 |

is used to identify unsafe practices which **would** result in minor personal injury or product and property damage. NOTE is used to highlight suggestions which **will** result in enhanced installation, reliability, or operation

INTRODUCTION

The model 350MAV, Series F furnaces are available in sizes 40,000 through 138,000 Btuh input capacities.

The 350MAV Multipoise Condensing Gas-Fired Furnaces are C.S.A. (A.G.A. and C.G.A.) certified for natural and propane gases and for installation in alcoves, attics, basements, closets, utility rooms, crawlspaces, and garages. The furnace is factory-shipped for use with natural gas. A C.S.A. (A.G.A. and C.G.A.) listed gas conversion kit is required to convert furnace for use with propane gas. The 350MAV 040 through 120 size units are C.S.A. (A.G.A. and C.G.A.) approved for use in manufactured (mobile) homes when factory accessory conversion kit is used. The 140 size unit is NOT approved for use in manufactured (mobile) homes. These furnaces are suitable for installation in a residence built on site or a manufactured residence completed at final site. The design of this furnace line is NOT C.S.A. (A.G.A. and C.G.A.) certified for installation in recreation vehicles or outdoors.

These furnaces SHALL NOT be installed directly on carpeting, tile, or any other combustible material other than wood flooring. In downflow installations, factory accessory floor base MUST be used when installed on combustible materials and wood flooring. Special base is not required when this furnace is installed on manufacturer's Coil Assembly Part No. CD5 or CK5, or when Coil Box Part No. KCAKC is used.

These furnaces are shipped with the following materials to assist in proper furnace installation. These materials are shipped in the main blower compartment.

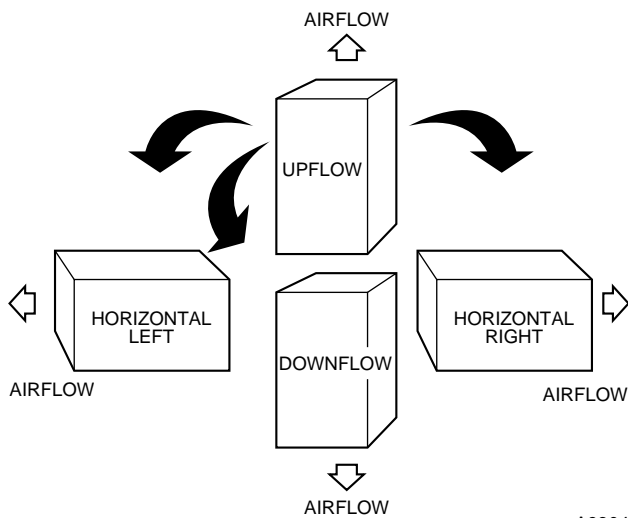

A93041

Fig. 1—Multipoise Orientations

SAFETY CONSIDERATIONS

Installing and servicing heating equipment can be hazardous due to gas and electrical components. Only trained and qualified personnel should install, repair, or service heating equipment. Untrained personnel can perform basic maintenance functions such as cleaning and replacing air filters. All other operations must be performed by trained service personnel. When working on heating equipment, observe precautions in literature, on tags, and on labels attached to or shipped with unit and other safety precautions that may apply.

Follow all safety codes. In the United States, follow all safety codes including the National Fuel Gas Code (NFGC) NFPA 54-1999/ANSI Z223.1-1999 and the Installation Standards, Warm Air Heating and Air Conditioning Systems (NFPA 90B) ANSI/NFPA 90B. In Canada, refer to the current edition of the CAN/CGA-B149.1- and .2-M00 National Standard of Canada, Natural Gas and Propane Installation Codes (NSCNGPIC). Wear safety glasses and work gloves. Have a fire extinguisher available during start-up and adjustment procedures and service calls.

Recognize safety information. This is the safety-alert symbol . When you see this symbol on the unit and in instructions or manuals, be alert to the potential for personal injury.

Understand these signal words DANGER, WARNING, CAUTION, and NOTE. These words are used with the safety-alert symbol. DANGER identifies the most serious hazards which **will** result in severe personal injury or death. WARNING signifies hazards which **could** result in personal injury or death. CAUTION

| Installer Packet includes: | |
|---|----------|
| Installation, Startup, and Operating Instructions | |
| Service and Maintenance Instructions | |
| User's Information Manual | |
| Warranty Certificate | |
| Loose Parts Bag includes | Quantity |
| Pressure tube extension | 1 |
| Collector Box or condensate trap extension tube | 1 |
| Inducer housing drain tube | 1 |
| 1/2-in CPVC street elbow | 2 |
| Drain tube coupling | 1 |
| Drain tube coupling grommet | 1 |
| Vent and combustion-air pipe support | 2 |
| Condensate trap hole filler plug | 3 |
| Vent and combustion-air intake hole filler plug | 2 |
| Combustion-air pipe perforated disk assembly | 1 |
| Vent Pipe Extension | 1* |

* ONLY supplied with some furnaces.

These furnaces are shipped with the drain and pressure tubes connected for UPFLOW applications. Minor modifications are required when used in DOWNFLOW, HORIZONTAL RIGHT, or HORIZONTAL LEFT (supply-air discharge direction) applications as shown in Fig. 1. See details in Applications section.

This furnace must be installed with a direct-vent (combustion air and flue) system and a factory accessory termination kit. In a direct-vent system, all air for combustion is taken directly from the outside atmosphere and all flue products are discharged to the outside atmosphere. See furnace and factory accessory termination kit instructions for proper installation.

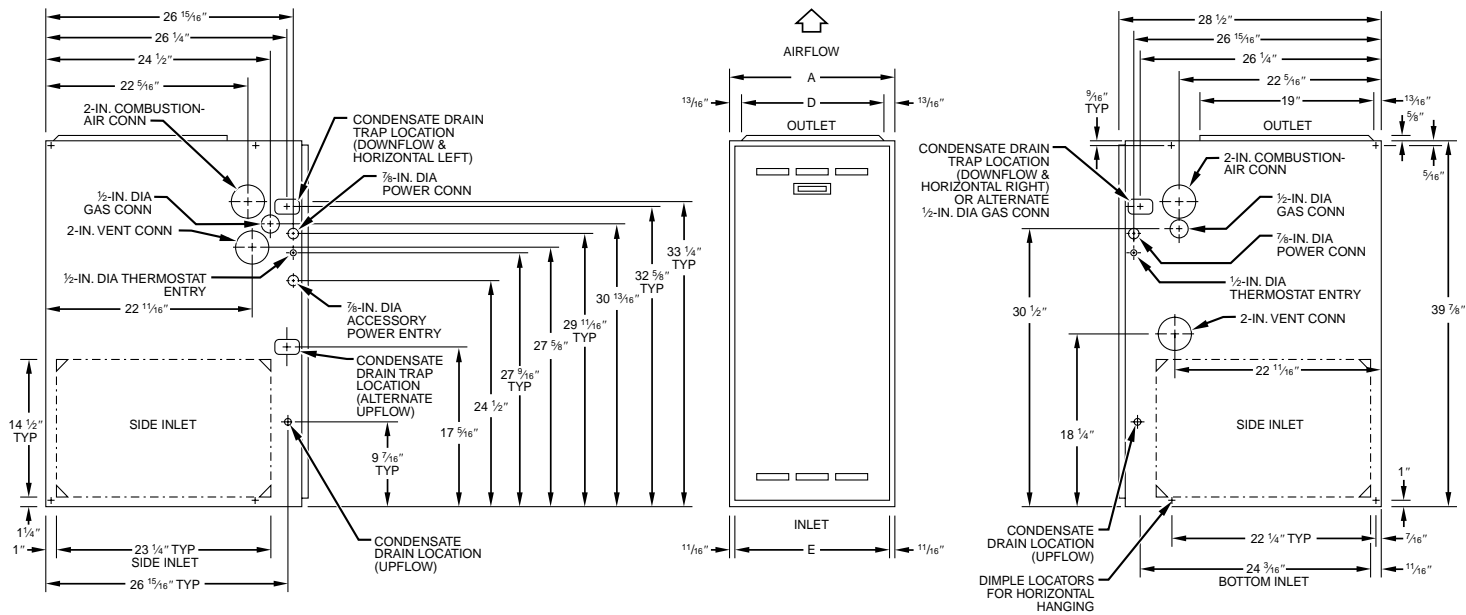

- NOTES:**
- Minimum return-air openings at furnace, based on metal duct. If flex duct is used, see flex duct manufacturer's recommendations for equivalent diameters.
 - Minimum return-air opening at furnace:
 - For 800 CFM—16-in. round or 14½ x 12-in. rectangle.
 - For 1200 CFM—20-in. round or 14½ x 19½-in. rectangle.
 - For 1600 CFM—22-in. round or 14½ x 23½-in. rectangle.
 - For airflow requirements above 1800 CFM, see Air Delivery table in Product Data literature for specific use of single side inlets. The use of both side inlets, a combination of 1 side and the bottom, or the bottom only will ensure adequate return air openings for airflow requirements above 1800 CFM.

DIMENSIONS (IN.)

| UNIT SIZE | A | D | E |
|-----------|--------|--------|--------|
| 024040 | 17-1/2 | 15-7/8 | 16 |
| 036040 | 17-1/2 | 15-7/8 | 16 |
| 024060 | 17-1/2 | 15-7/8 | 16 |
| 036060 | 17-1/2 | 15-7/8 | 16 |
| 048060 | 17-1/2 | 15-7/8 | 16 |
| 036080 | 17-1/2 | 15-7/8 | 16 |
| 048080 | 17-1/2 | 15-7/8 | 16 |
| 060080 | 21 | 19-3/8 | 19-1/2 |
| 048100 | 21 | 19-3/8 | 19-1/2 |
| 060100 | 21 | 19-3/8 | 19-1/2 |
| 060120 | 24-1/2 | 22-7/8 | 23 |
| 060140 | 24-1/2 | 22-7/8 | 23 |

Fig. 2—Dimensional Drawing

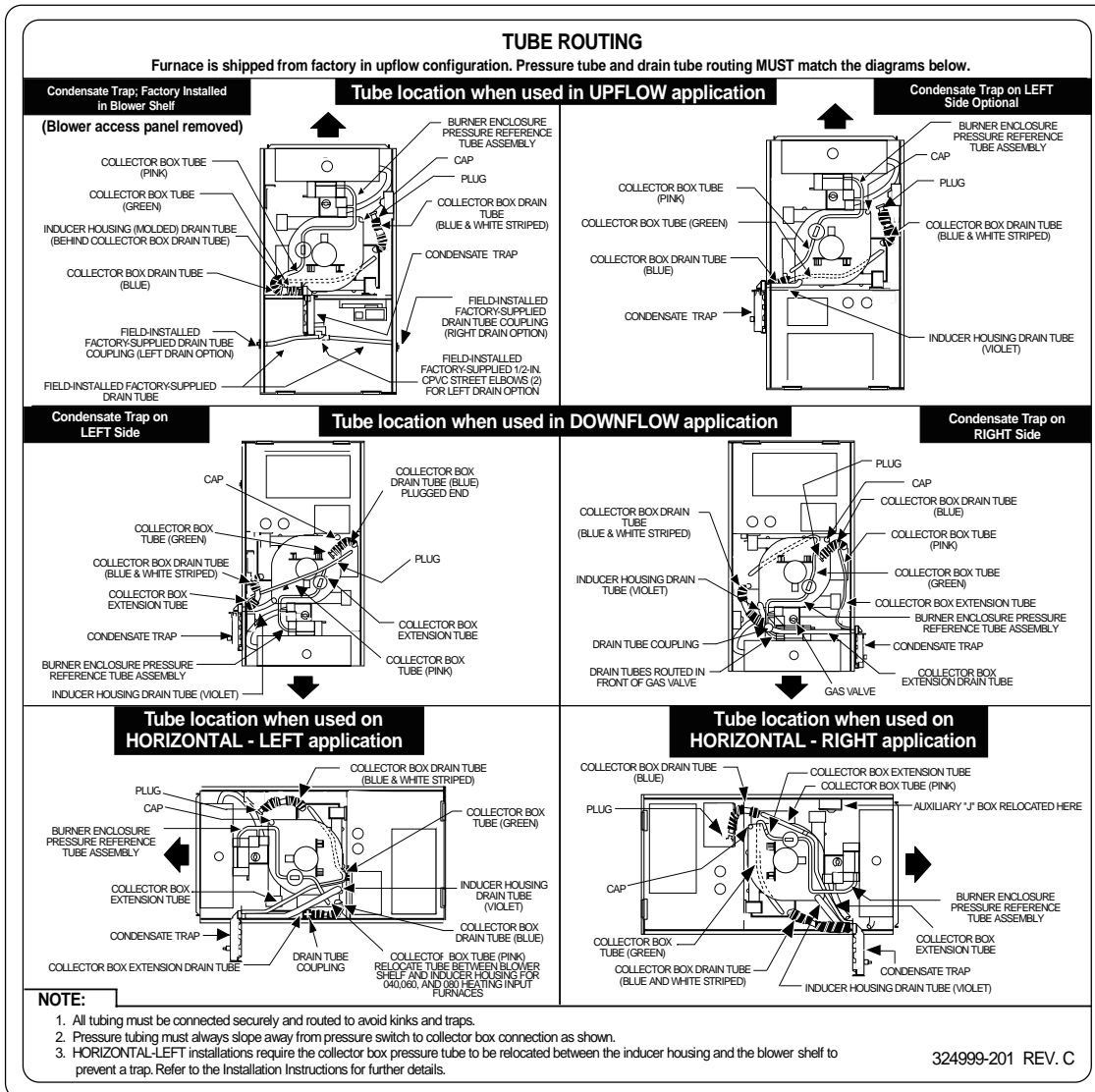

A00308

Fig. 3—Clearances to Combustibles

CAUTION: Application of this furnace should be indoors with special attention given to vent sizing and material, gas input rate, air temperature rise, unit leveling, and unit sizing. Improper installation or misapplication of furnace can require excessive servicing or cause premature component failure.

WARNING: Improper installation, adjustment, alteration, service, maintenance, or use can cause carbon monoxide poisoning, explosion, tire, electrical shock, or other conditions which may cause personal injury or property damage. Consult a qualified installer, service agency, local gas supplier, or your distributor or branch for information or assistance. The qualified installer or agency must use only factory-authorized and listed kits or accessories when modifying this product. Failure to follow this warning could result in electrical shock, fire, personal injury, or death.

CODES AND STANDARDS

Before installing the furnace in the United States, refer to the current edition of the NFGC and the NFPA 90B.

For copies of the NFGC and NFPA 90B contact the National Fire Protection Association Inc., Batterymarch Park, Quincy, MA 02269; or the American Gas Association, 1515 Wilson Boulevard, Arlington, VA 22209.

Before installing the furnace in Canada, refer to the current edition of the NSCNPIC. Contact Standard Sales, CSA International, 178 Rexdale Boulevard, Etobicoke, (Toronto) Ontario, Canada M9W 1R3.

Installation must comply with regulations of serving gas supplier and local building, heating, plumbing or other codes in effect in the area in which installation is made. In the absence of local codes, installation must conform with the NFGC in the United States and the NSCNPIC in Canada

These instructions cover minimum requirements for a safe installation and conform to existing national standards and safety codes. In some instances, these instructions exceed certain local codes and ordinances, especially those that may not have kept pace with changing residential construction practices. We require these instructions as a minimum for a safe installation.

For accessory installation detail, refer to applicable installation literature.

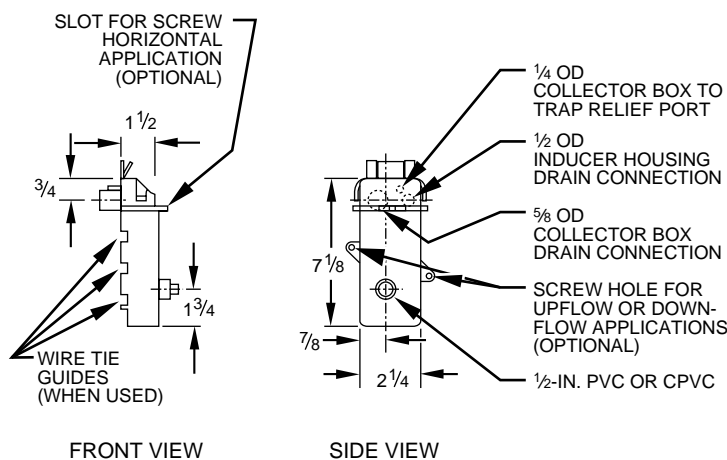
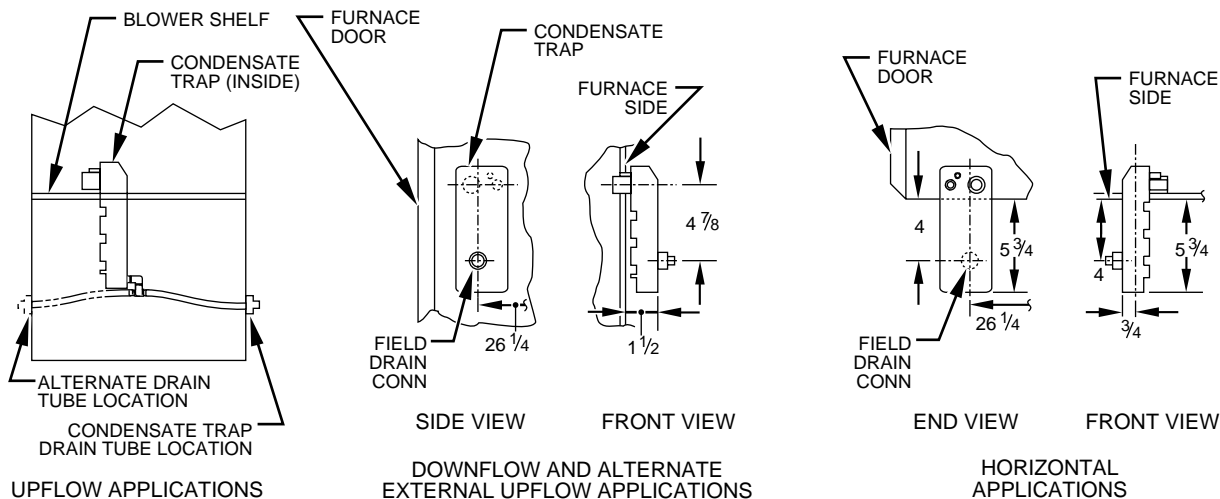

Fig. 4—Condensate Trap

A93026

ELECTROSTATIC DISCHARGE (ESD) PRECAUTIONS

CAUTION: Electrostatic discharge can affect electronic components. Take precautions during furnace installation and servicing to protect the furnace electronic control. Precautions will prevent electrostatic discharges from personnel and hand tools which are held during the procedure. These precautions will help to avoid exposing the control to electrostatic discharge by putting the furnace, the control, and the person at the same electrostatic potential.

1. Disconnect all power to the furnace. **DO NOT TOUCH THE CONTROL OR ANY WIRE CONNECTED TO THE CONTROL PRIOR TO DISCHARGING YOUR BODY'S ELECTROSTATIC CHARGE TO GROUND.**
2. Firmly touch a clean, unpainted, metal surface of the furnace chassis which is close to the control. Tools held in a person's hand during grounding will be satisfactorily discharged.
3. After touching the chassis you may proceed to service the control or connecting wires as long as you do nothing that recharges your body with static electricity (for example; **DO NOT** move or shuffle your feet, **DO NOT** touch ungrounded objects, etc.).
4. If you touch ungrounded objects (and recharge your body with static electricity), firmly touch furnace again before touching control or wires.

5. Use this procedure for installed and uninstalled (ungrounded) furnaces.
6. Before removing a new control from its container, discharge your body's electrostatic charge to ground to protect the control from damage. If the control is to be installed in a furnace, follow items 1 through 5 before bringing the control or yourself into contact with the furnace. Put all used **AND** new controls into containers before touching ungrounded objects.
7. An ESD service kit (available from commercial sources) may also be used to prevent ESD damage.

APPLICATIONS

I. GENERAL

Some assembly and modifications are required for furnaces installed in any of the 4 applications shown in Fig. 1. All drain and pressure tubes are connected as shown in Fig. 5. See appropriate application instructions for these procedures.

II. UPFLOW APPLICATIONS

An upflow furnace application is where furnace blower is located below combustion and controls section of furnace, and conditioned air is discharged upwards.

A. Condensate Trap Location (Factory-Shipped Orientation)

The condensate trap is factory installed in the blower shelf and factory connected for UPFLOW applications. A factory-supplied

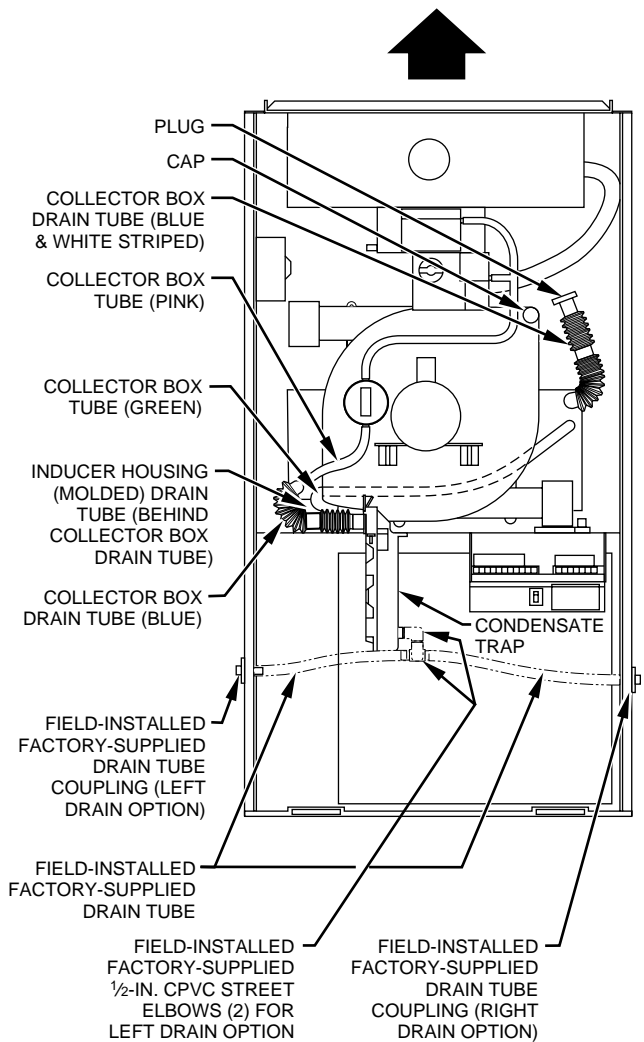

A94163

Fig. 5—Factory-Shipped Upflow Tube Configuration

(Shown with Blower Access Panel Removed)

tube is used to extend the condensate trap drain connection to the desired furnace side for field drain attachment. See Condensate Trap Tubing (Factory-Shipped Orientation) section for drain tube extension details.

B. Condensate Trap Tubing (Factory-Shipped Orientation)

NOTE: See Fig. 5 or tube routing label on main furnace door to confirm location of these tubes.

1. Collector Box Drain, Inducer Housing Drain, Relief Port, and Pressure Switch Tubes.

These tubes should be factory attached to condensate trap and pressure switch ready for use in UPFLOW applications. These tubes can be identified by their connection location and also by a color label on each tube. These tubes are identified as follows: collector box drain tube (blue label), inducer housing drain tube (violet label or molded), relief port tube (green label), and pressure switch tube (pink label).

2. Condensate Trap Drain Tube

The condensate trap drain connection must be extended for field attachment by doing the following:

- a. Determine location of field drain connection. (See Fig. 2 or 5.)

NOTE: If internal filter or side Filter/Media Cabinet is used, drain tube should be located to opposite side of casing of return duct attachment to assist in filter removal.

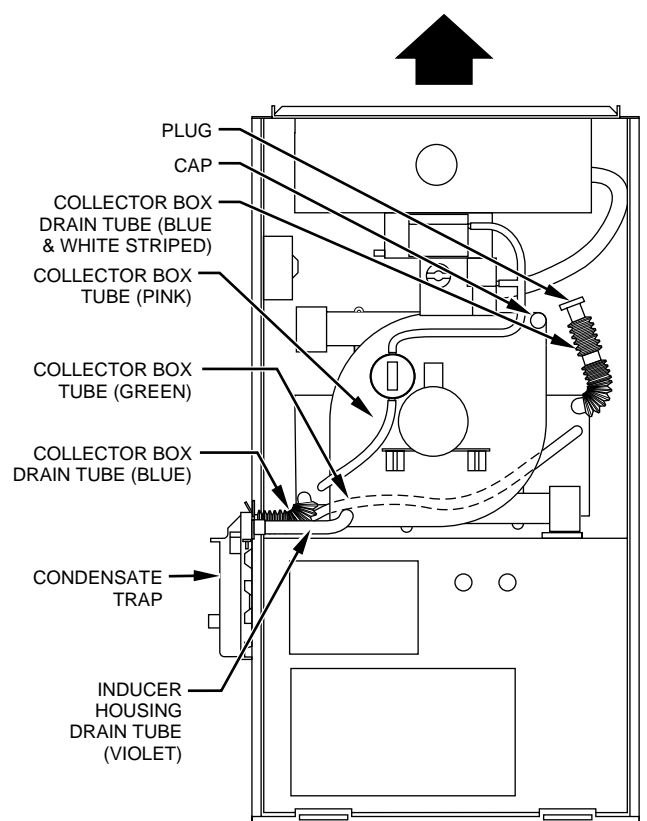

A94164

Fig. 6—Alternate Upflow Configuration and Trap Location

- b. Remove and discard casing drain hole plug button from desired side.
- c. Install drain tube coupling grommet (factory-supplied in loose parts bag) in selected casing hole.
- d. Slide drain tube coupling (factory-supplied in loose parts bag) through grommet ensuring long end of coupling faces blower.
- e. Cement 2 factory-supplied 1/2-in. street CPVC elbows to the rigid drain tube connection on the condensate trap. (See Fig. 5.) These elbows must be cemented together and cemented to condensate trap drain connection.
- f. Connect larger diameter drain tube and clamp (factory-supplied in loose parts bag) to condensate trap and clamp securely.
- g. Route tube to coupling and cut to appropriate length.
- h. Attach tube to coupling and clamp securely.

NOTE: Failure to use CPVC elbows may allow drain to kink and prevent draining.

C. Condensate Trap Location (Alternate Upflow Orientation)

An alternate location for the condensate trap is the left-hand side of casing. (See Fig. 2 and 6.)

NOTE: If the alternate left-hand side of casing location is used, the factory-connected drain and relief port tubes must be disconnected and modified for attachment. See Condensate Trap Tubing (Alternate Upflow Orientation) section for tubing attachment.

To relocate condensate trap to the left-hand side, perform the following:

1. Remove 3 tubes connected to condensate trap.
2. Remove trap from blower shelf by gently pushing tabs inward and rotating trap.

3. Install casing hole filler cap (factory-supplied in loose parts bag) into blower shelf hole where trap was removed.
4. Install condensate trap into left-hand side casing hole by inserting tube connection stubs through casing hole and rotating until tabs snap into locking position.
5. Fill unused condensate trap casing holes with plastic filler caps (factory-supplied in loose parts bag).

D. Condensate Trap Tubing (Alternate Upflow Orientation)

NOTE: See Fig. 6 or tube routing label on main furnace door to confirm location of these tubes.

1. Collector Box Drain Tube
Connect collector box drain tube (blue label) to condensate trap.

NOTE: On 17-1/2 in. wide furnaces ONLY, cut tube between corrugated sections to prevent kinks from occurring.

2. Inducer Housing Drain Tube
 - a. Remove and discard LOWER (molded) inducer housing drain tube which was previously connected to condensate trap.
 - b. Use inducer housing drain extension tube (violet label and factory-supplied in loose parts bag) to connect LOWER inducer housing drain connection to the condensate trap.
 - c. Determine appropriate length, cut, and connect tube.
 - d. Clamp tube to prevent any condensate leakage.
3. Relief Port Tube
 - a. Connect relief port tube (green label) to condensate trap.
 - b. Extend this tube (if required) by splicing to small diameter tube (factory-supplied in loose parts bag).
 - c. Determine appropriate length, cut, and connect tube.

E. Condensate Trap Field Drain Attachment

Refer to Condensate Drain section for recommendations and procedures.

F. Pressure Switch Tubing

The LOWER collector box pressure tube (pink label) is factory connected to the pressure switch and should not require any modification.

NOTE: See Fig. 5 or 6 or tube routing label on main furnace door to check for proper connections.

G. Upper Collector Box and Inducer Housing (Unused) Drain Connections

UPPER COLLECTOR BOX DRAIN CONNECTION

Attached to the UPPER collector box drain connection is a factory-installed corrugated, plugged tube (blue and white striped label). This tube is plugged to prevent condensate leakage in this application. Ensure this tube is plugged.

NOTE: See Fig. 5 or 6 or tube routing label on main furnace door to check for proper connections.

UPPER INDUCER HOUSING DRAIN CONNECTION

Attached to the UPPER (unused) inducer housing drain connection is a cap and clamp. This cap is used to prevent condensate leakage in this application. Ensure this connection is capped.

NOTE: See Fig. 5 or 6 or tube routing label on main furnace door to check for proper connections.

H. Condensate Trap Freeze Protection

Refer to Condensate Drain Protection section for recommendations and procedures.

III. DOWNFLOW APPLICATIONS

A downflow furnace application is where furnace blower is located above combustion and controls section of furnace, and conditioned air is discharged downwards.

A. Condensate Trap Location

The condensate trap must be removed from the factory-installed blower shelf location and relocated in selected application location as shown in Fig. 2, 7, or 8.

To relocate condensate trap from the blower shelf to desired location, perform the following:

1. Remove 3 tubes connected to condensate trap.
2. Remove trap from blower shelf by gently pushing tabs inward and rotating trap.
3. Remove casing hole filler cap from casing hole. (See Fig. 2, 7, or 8).
4. Install casing hole filler cap into blower shelf hole where trap was removed.
5. Install condensate trap into desired casing hole by inserting tube connection stubs through casing hole and rotating until tabs snap into locking position.

B. Condensate Trap Tubing

NOTE: See Fig. 7 or 8 or tube routing label on main furnace door to check for proper connections.

Relocate tubes as described below.

1. Collector Box Drain Tube
 - a. Remove factory-installed plug from LOWER collector box drain tube (blue and white striped label).
 - b. Install removed clamp and plug into UPPER collector box drain tube (blue label) which was connected to condensate trap.
 - c. Connect LOWER collector box drain connection to condensate trap.
 - (1.) Condensate Trap Located on Left Side of Casing
 - (a.) Connect LOWER collector box drain tube (blue and white striped label) to condensate trap. Tube does not need to be cut.
 - (b.) Clamp tube to prevent any condensate leakage.
 - (2.) Condensate Trap Located on Right Side of Casing
 - (a.) Install drain tube coupling (factory-supplied in loose parts bag) into collector box drain tube (blue and white striped label) which was previously plugged.
 - (b.) Connect larger diameter drain tube (factory-supplied in loose parts bag) to drain tube coupling, extending collector box drain tube for connection to condensate trap.
 - (c.) Route extended collector box drain tube directly from collector box drain to condensate trap as shown in Fig. 8.
 - (d.) Determine appropriate length and cut.
 - (e.) Connect to condensate trap.
 - (f.) Clamp tube to prevent any condensate leakage.
2. Inducer Housing Drain Tube
 - a. Remove factory-installed cap and clamp from LOWER inducer housing drain connection.
 - b. Remove and discard UPPER (molded) inducer housing drain tube which was previously connected to condensate trap.

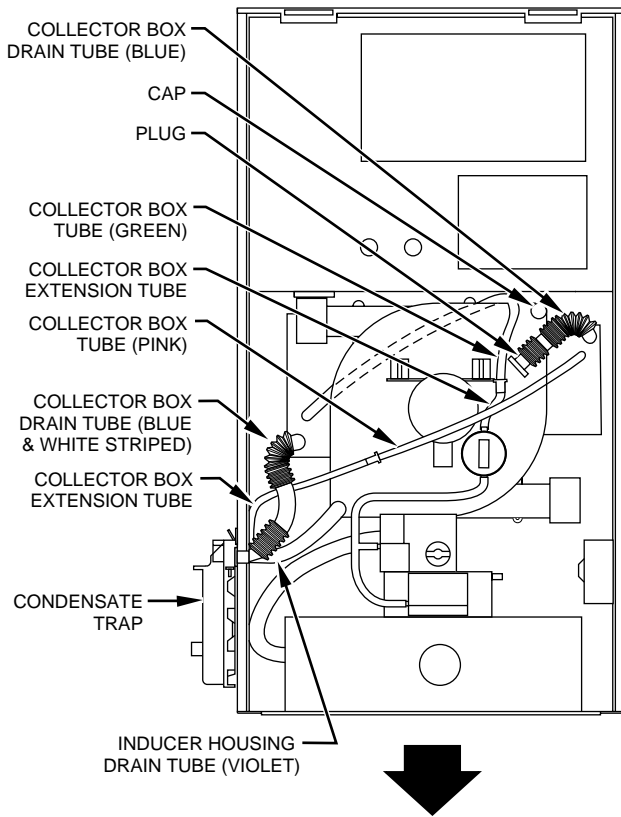

Fig. 7—Downflow Tube Configuration (Left-Hand Trap Installation)

A94165

- c. Install cap and clamp on UPPER inducer housing drain connection where molded drain tube was removed.
- d. Use inducer housing drain tube (violet label and factory-supplied in loose parts bag) to connect LOWER inducer housing drain connection to the condensate trap.
- e. Connect inducer housing drain connection to condensate trap.
 - (1.) Condensate Trap Located on Left Side of Casing
 - (a.) Determine appropriate length and cut.
 - (b.) Connect tube to condensate trap.
 - (c.) Clamp tube to prevent any condensate leakage.
 - (2.) Condensate Trap Located on Right Side of Casing
 - (a.) Route inducer housing drain tube (violet label) directly from inducer housing to condensate trap as shown in Fig. 8.
 - (b.) Determine appropriate length and cut.
 - (c.) Connect tube to condensate trap.
 - (d.) Clamp tube to prevent any condensate leakage.

3. Relief Port Tube

Refer to Pressure Switch Tubing section for connection procedure.

C. Condensate Trap Field Drain Attachment

Refer to Condensate Drain section for recommendations and procedures.

D. Pressure Switch Tubing

One collector box pressure tube (pink label) is factory connected to the pressure switch for use when furnace is installed in UPFLOW applications. This tube **MUST** be disconnected and used for the condensate trap relief port tube. The other collector box pressure tube (green label) which was factory connected to the condensate trap relief port connection **MUST** be connected to the pressure switch in DOWNFLOW or HORIZONTAL RIGHT applications.

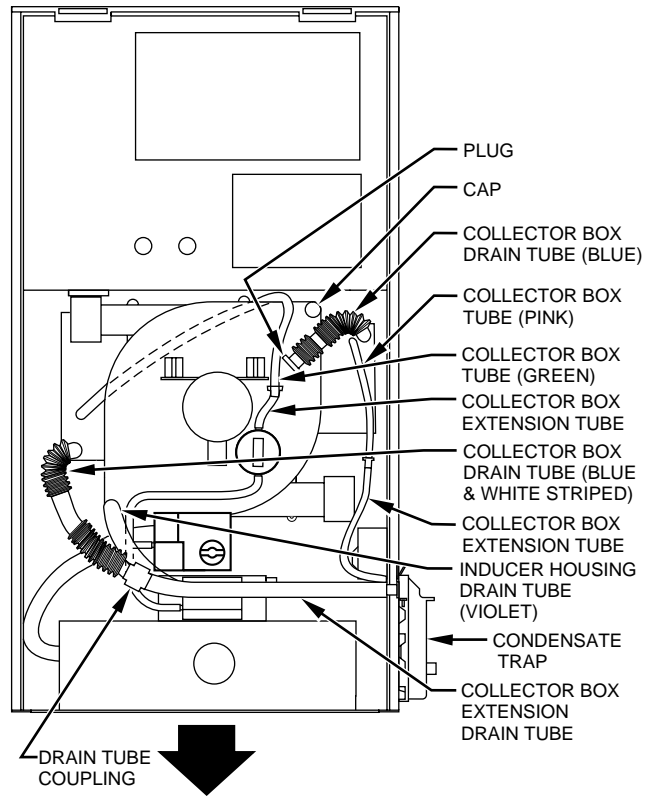

Fig. 8—Downflow Tube Configuration (Right-Hand Trap Installation)

A94166

NOTE: See Fig. 7 or 8 or tube routing label on main furnace door to check for proper connections.

1. Disconnect collector box pressure tube (pink label) attached to pressure switch.
2. Extend collector box pressure tube (green label) which was previously connected to condensate trap relief port connection by splicing to small diameter tube (factory-supplied in loose parts bag).
3. Connect collector box pressure tube (green label) to pressure switch connection labeled COLLECTOR BOX.
4. Extend collector box pressure tube (pink label) which was previously connected to pressure switch by splicing to remaining small diameter tube (factory-supplied in loose parts bag).
5. Route this extended tube (pink label) to condensate trap relief port connection.
6. Determine appropriate length, cut, and connect tube.
7. Clamp tube to relief port connection.

E. Condensate Trap Freeze Protection

Refer to Condensate Drain Protection section for recommendations and procedures.

IV. HORIZONTAL LEFT (SUPPLY-AIR DISCHARGE) APPLICATIONS

A horizontal left furnace application is where furnace blower is located to the right of combustion and controls section of furnace, and conditioned air is discharged to the left.

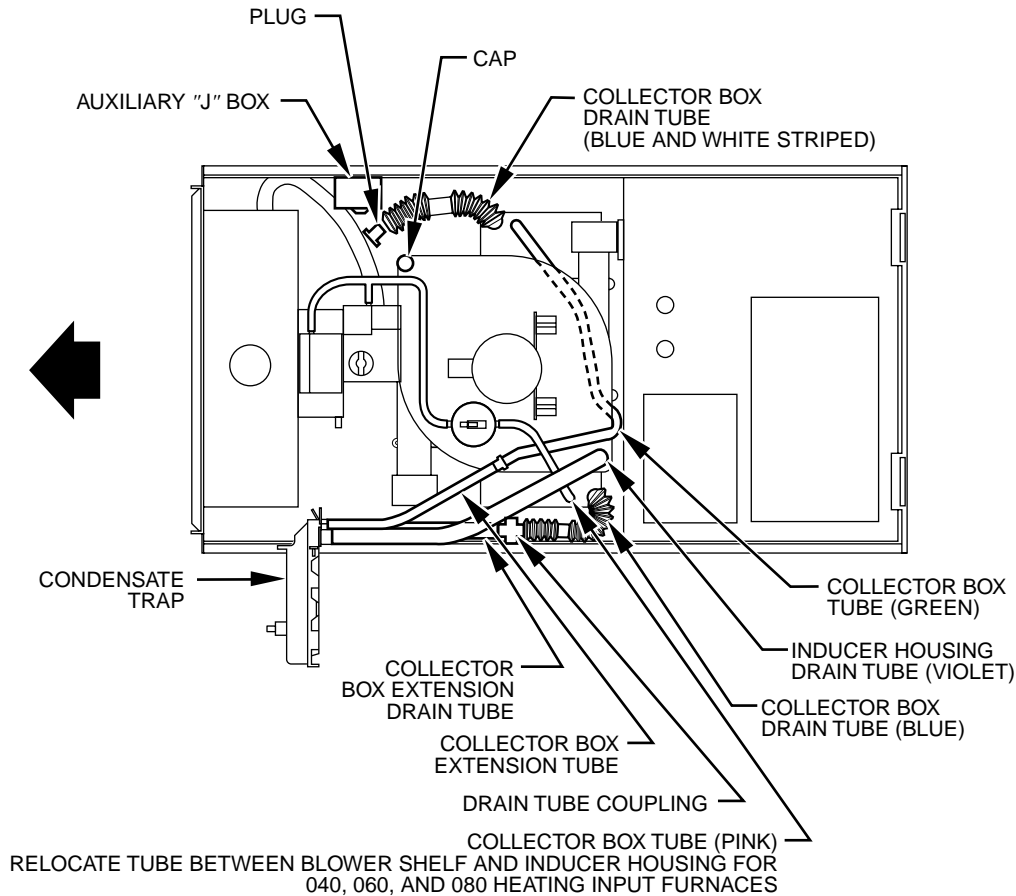

A00215

Fig. 9—Horizontal Left Tube Configuration

| | |
|--|---|
| | <p>CAUTION: Local codes may require a drain pan under entire furnace and condensate trap when a condensing furnace is used in an attic application or over a finished ceiling.</p> |
|--|---|

NOTE: In Canada, installations shall be in accordance with current NSCPGIC and/or local codes.

A. Condensate Trap Location

The condensate trap must be removed from the factory-installed blower shelf location and relocated in selected application location as shown in Fig. 2 or 9.

To relocate condensate trap from the blower shelf to desired location, perform the following:

1. Remove 3 tubes connected to condensate trap.
2. Remove trap from blower shelf by gently pushing tabs inward and rotating trap.
3. Install casing hole filler cap (factory-supplied in loose parts bag) into blower shelf hole where trap was removed.
4. Install condensate trap into left-hand side casing hole by inserting tube connection stubs through casing hole and rotating until tabs snap into locking position.
5. Fill unused condensate trap casing holes with plastic filler caps (factory-supplied in loose parts bag).

B. Condensate Trap Tubing

NOTE: See Fig. 9 or tube routing label on main furnace door to check for proper connections.

1. Collector Box Drain Tube
 - a. Install drain tube coupling (factory-supplied in loose parts bag) into collector box drain tube (blue label) which was previously connected to condensate trap.

- b. Connect large diameter drain tube and clamp (factory-supplied in loose parts bag) to drain tube coupling, extending collector box drain tube.
- c. Route extended tube (blue label) to condensate trap and cut to appropriate length.
- d. Clamp tube to prevent any condensate leakage.

2. Inducer Housing Drain Tube

- a. Remove and discard LOWER (molded) inducer housing drain tube which was previously connected to condensate trap.
- b. Use inducer housing drain extension tube (violet label and factory-supplied in loose parts bag) to connect LOWER inducer housing drain connection to the condensate trap.
- c. Determine appropriate length, cut, and connect tube.
- d. Clamp tube to prevent any condensate leakage.

3. Relief Port Tube

- a. Extend collector box tube (green label) which was previously connected to the condensate trap by splicing to small diameter tube (factory-supplied in loose parts bag).
- b. Route extended collector box pressure tube to relief port connection on the condensate trap.
- c. Determine appropriate length, cut, and connect tube.
- d. Clamp tube to prevent any condensate leakage.

C. Condensate Trap Field Drain Attachments

Refer to Condensate Drain section for recommendations and procedures.

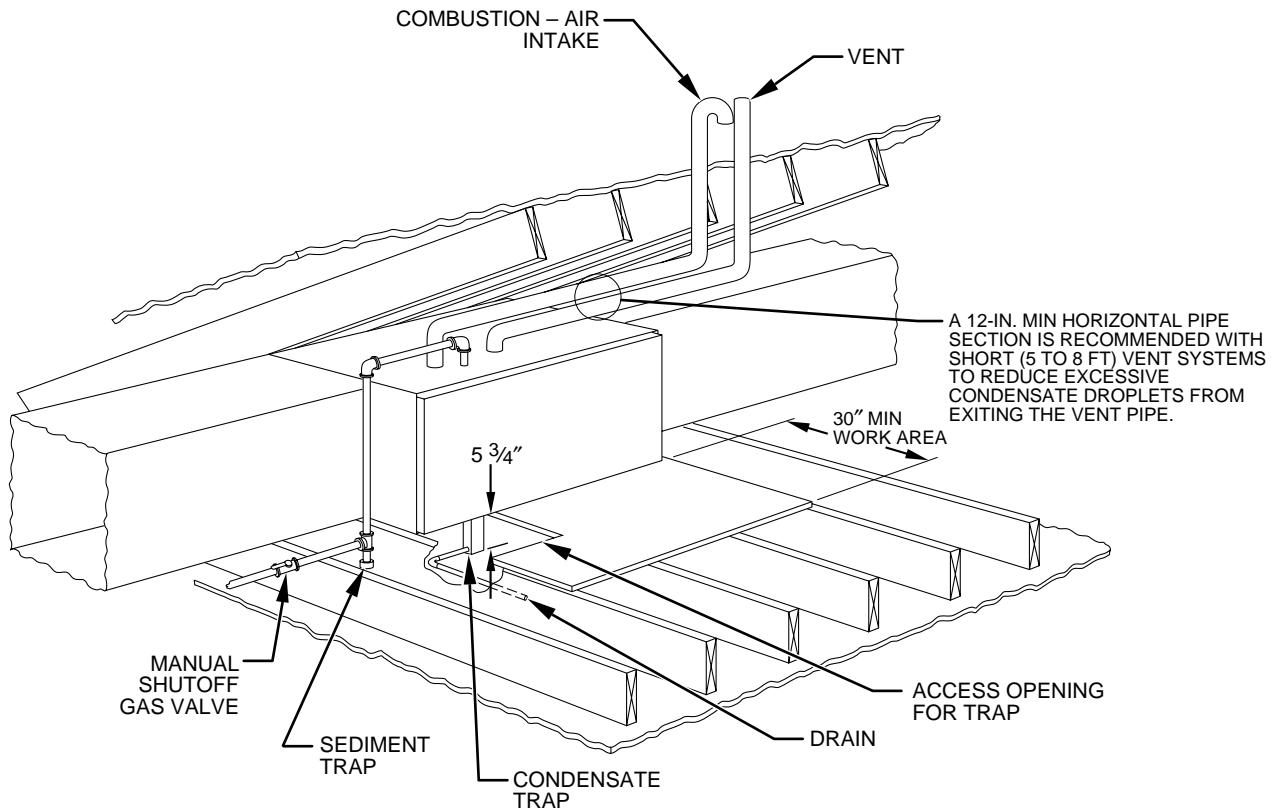

NOTE: LOCAL CODES MAY REQUIRE A DRAIN PAN UNDER THE FURNACE AND CONDENSATE TRAP WHEN A CONDENSING FURNACE IS INSTALLED ABOVE FINISHED CEILINGS.

A93031

Fig. 10—Attic Location and Working Platform

D. Pressure Switch Tubing

The LOWER collector box pressure tube (pink label) is factory connected to the pressure switch for use when furnace is installed in UPFLOW applications. This tube **MUST** be disconnected, extended, rerouted, and then reconnected to the pressure switch in HORIZONTAL LEFT applications.

NOTE: See Fig. 9 or tube routing label on main furnace door to check for proper connections.

Modify tube as described below.

1. Disconnect collector box pressure tube (pink label) attached to pressure switch.
2. Use smaller diameter tube (factory-supplied in loose parts bag) to extend tube disconnected in item 1.
3. Route extended tube:
 - a. Behind inducer housing.
 - b. Between blower shelf and inducer housing.
 - c. Behind inducer motor bracket.
 - d. Between inducer motor and pressure switch.
4. Determine appropriate length, cut, and reconnect tube to pressure switch connection labeled COLLECTOR BOX.

E. Condensate Trap Freeze Protection

Refer to Condensate Drain Protection section for recommendations and procedures.

F. Construct a Working Platform

Construct working platform where all required furnace clearances are met. (See Fig. 3 and 10.)

CAUTION: The condensate trap **MUST** be installed below furnace. See Fig. 4 for dimensions. The drain connection to condensate trap must also be properly sloped to an open drain.

NOTE: Combustion-air and vent pipes are restricted to a minimum length of 5 ft. (See Table 7.)

NOTE: A 12-in. minimum offset pipe section is recommended with short (5 to 8 ft) vent systems. This recommendation is to reduce excessive condensate droplets from exiting the vent pipe. (See Fig. 10 or 34.)

V. HORIZONTAL RIGHT (SUPPLY-AIR DISCHARGE) APPLICATIONS

A horizontal right furnace application is where furnace blower is located to the left of combustion and controls section of furnace, and conditioned air is discharged to the right.

CAUTION: Local codes may require a drain pan under entire furnace and condensate trap when a condensing furnace is used in attic application or over a finished ceiling.

NOTE: In Canada, installations shall be in accordance with current NSCSGPIIC Installation Codes and/or local codes.

NOTE: The auxiliary junction box (J-Box) **MUST** be relocated to opposite side of furnace casing. (See Fig. 11.) See Electrical Connection section for J-Box relocation.

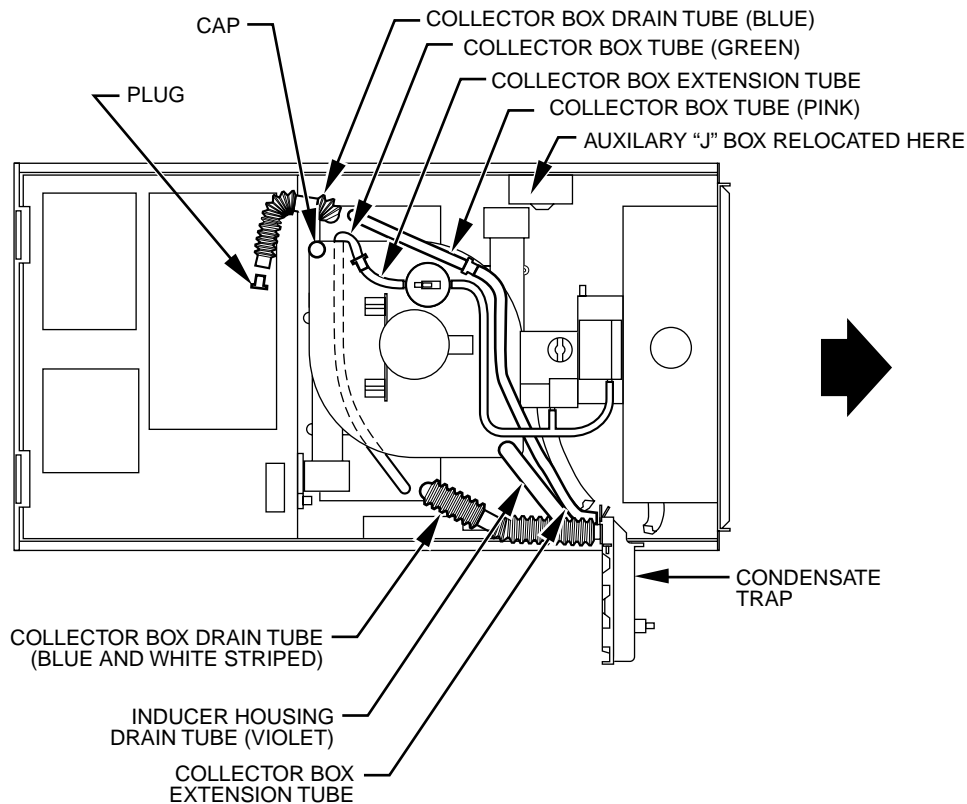

A00214

Fig. 11—Horizontal Right Tube Configuration

A. Condensate Trap Location

The condensate trap must be removed from the factory-installed blower shelf location and relocated in selected application location as shown in Fig. 2 or 11.

To relocate condensate trap from the blower shelf to desired location, perform the following:

1. Remove 3 tubes connected to condensate trap.
2. Remove trap from blower shelf by gently pushing tabs inward and rotating trap.
3. Install casing hole filler cap (factory-supplied in loose parts bag) into blower shelf hole where trap was removed.
4. Install condensate trap into left-hand side casing hole by inserting tube connection stubs through casing hole and rotating until tabs snap into locking position.
5. Fill unused condensate trap casing holes with plastic filler caps (factory-supplied in loose parts bag).

B. Condensate Trap Tubing

NOTE: See Fig. 11 or tube routing label on main furnace door to check for proper connections.

1. Collector Box Drain Tube
 - a. Remove factory-installed plug from LOWER collector box drain tube (blue and white striped label).
 - b. Install removed clamp and plug into UPPER collector box drain tube (blue label) which was previously connected to condensate trap.
 - c. Connect LOWER collector box drain tube (blue and white striped label) to condensate trap. Tube does not need to be cut.
 - d. Clamp tube to prevent any condensate leakage.
2. Inducer Housing Drain Tube
 - a. Remove factory-installed cap and clamp from LOWER inducer housing drain connection.

- b. Remove and discard UPPER (molded) inducer housing drain tube which was previously connected to condensate trap.
- c. Install cap and clamp on UPPER inducer housing drain connection where molded drain tube was removed.
- d. Use inducer housing drain extension tube (violet label and factory-supplied in loose parts bag) to connect LOWER inducer housing drain connection to condensate trap.
- e. Determine appropriate length, cut, and connect tube to condensate trap.
- f. Clamp tube to prevent any condensate leakage.

3. Relief Port Tube

Refer to Pressure Switch Tubing section for connection procedure.

C. Condensate Trap Field Drain Attachment

Refer to Condensate Drain section for recommendations and procedures.

D. Pressure Switch Tubing

One collector box pressure tube (pink label) is factory connected to the pressure switch for use when furnace is installed in UPFLOW applications. This tube **MUST** be disconnected and used for the condensate trap relief port tube. The other collector box pressure tube (green label) which was factory connected to the condensate trap relief port connection **MUST** be connected to the pressure switch in DOWNFLOW or HORIZONTAL RIGHT applications.

NOTE: See Fig. 11 or tube routing label on main furnace door to check for proper connections.

Relocate tubes as described below.

1. Disconnect collector box pressure tube (pink label) attached to pressure switch.

2. Extend collector box pressure tube (green label) which was previously connected to condensate trap relief port connection by splicing to small diameter tube (factory-supplied in loose parts bag).
3. Route extended collector box pressure tube behind inducer motor bracket then between inducer motor and pressure switch.
4. Connect collector box pressure tube (green label) to pressure switch connection labeled COLLECTOR BOX.
5. Use remaining smaller diameter tube (factory-supplied in loose parts bag) to extend collector box pressure tube (pink label) which was previously connected to pressure switch.
6. Route this extended tube (pink label) to condensate trap relief port connection.
7. Determine appropriate length, cut, and connect tube.
8. Clamp tube to relief port connection.

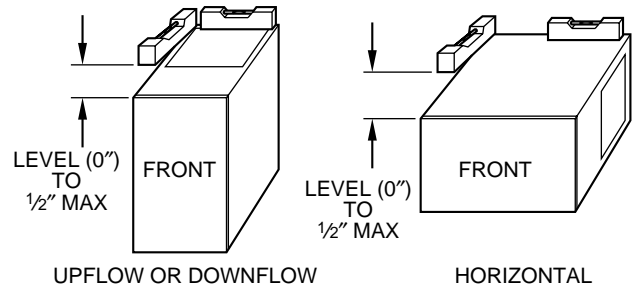

A93025

Fig. 12—Furnace Location for Proper Condensate Drainage

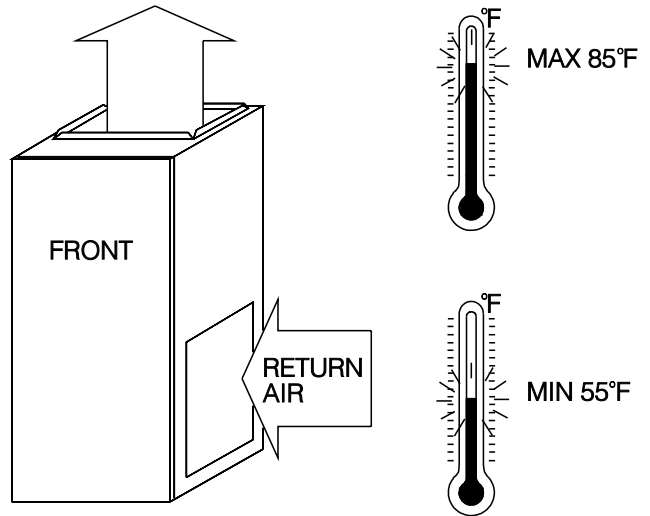

A93042

Fig. 13—Return-Air Temperature

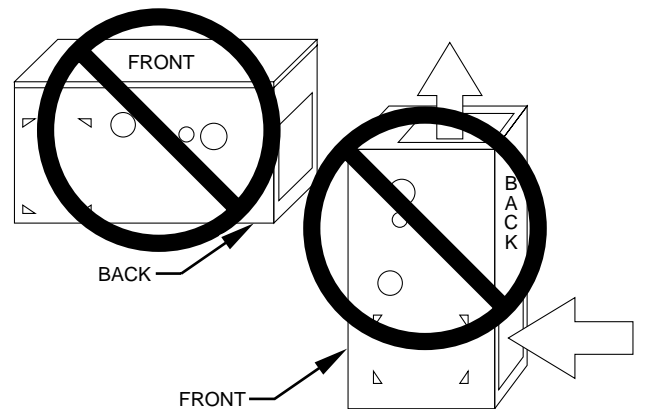

A93043

Fig. 14—Prohibit Installation on Back

E. Condensate Trap Freeze Protection

Refer to Condensate Drain Protection section for recommendations and procedures.

F. Construct a Working Platform

Construct working platform where all required furnace clearances are met. (See Fig. 3 and 10.)

| | |
|---|---|
| ⚠ | CAUTION: The condensate trap MUST be installed below furnace. See Fig. 4 for dimensions. The drain connection to condensate trap must also be properly sloped to an open drain. |
|---|---|

NOTE: Combustion-air and vent pipes are restricted to a minimum length of 5 ft. (See Table 7.)

NOTE: A 12-in. minimum offset pipe section is recommended with short (5 to 8 ft) vent systems. This recommendation is to reduce excessive condensate droplets from exiting the vent pipe. (See Fig. 10 or 34.)

LOCATION

I. GENERAL

When a furnace is installed so that supply ducts carry air to areas outside the space containing the furnace, return air must also be handled by ducts sealed to furnace casing. The ducts terminate outside the space containing the furnace to ensure there will not be a negative pressure condition within equipment room or space. Furnace may be located in a confined space without special provisions for dilution or ventilation air. This furnace must be installed so electrical components are protected from water.

Locate furnace as close to center of air distribution system as possible.

NOTE: For proper furnace operation, install furnace so that it is level or pitched forward within 1/2 in. to ensure proper condensate drainage from secondary heat exchangers. (See Fig. 12.)

NOTE: These furnaces are designed for a minimum continuous return-air temperature of 60°F or intermittent operation down to 55°F such as when used with a night setback thermostat. Return-air temperature must not exceed a maximum of 85°F. Failure to follow these return-air temperature limits may affect reliability of heat exchangers, motors, and controls. (See Fig. 13.)

Locate furnace so combustion-air pipe maximum lengths are not exceeded. Refer to Table 7.

| | |
|---|--|
| ⚠ | WARNING: Do not install furnace on its back. Safety control operation will be adversely affected. Never connect return-air ducts to back of furnace. Failure to follow this warning could result in fire, personal injury, or death. (See Fig. 14.) |
|---|--|

CAUTION: If these furnaces are used during construction when adhesives, sealers, and/or new carpets are being installed, make sure all combustion and circulating air requirements are followed. If operation of furnace is required during construction, use clean outside air for combustion and ventilation. Compounds of chlorine and fluorine, when burned with combustion air, form acids which will cause corrosion of heat exchangers. Some of these compounds are found in paneling, dry wall adhesives, paints, thinners, masonry cleaning materials, and many other solvents commonly used in construction process. Excessive exposure to contaminated combustion air will result in safety and performance related problems.

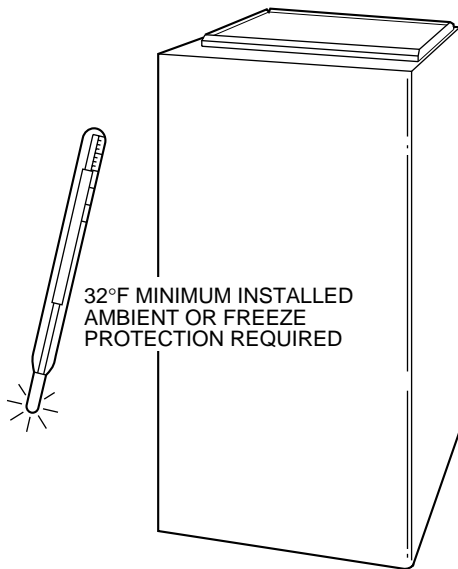

Fig. 15—Freeze Protection

A93058

CAUTION: If these furnaces are installed in an unconditioned space where the ambient temperatures may be 32°F or lower, freeze protection measures must be taken. (See Fig. 15.)

Provide ample space for servicing and cleaning. Always comply with minimum fire protection clearances shown on units clearance and combustibles label. (See Fig. 3.) Locate furnace where available electric power and gas supplies meet specifications on furnace rating plate.

II. FURNACE LOCATION RELATIVE TO COOLING EQUIPMENT

The cooling coil must be installed parallel with or on downstream side of furnace to avoid condensation in heat exchanger. When installed parallel with a furnace, dampers or other means used to control flow of air must prevent chilled air from entering furnace. If dampers are manually operated, they must be equipped with a means to prevent operation of either unit unless damper is in full-heat or full-cool position.

III. HAZARDOUS LOCATIONS

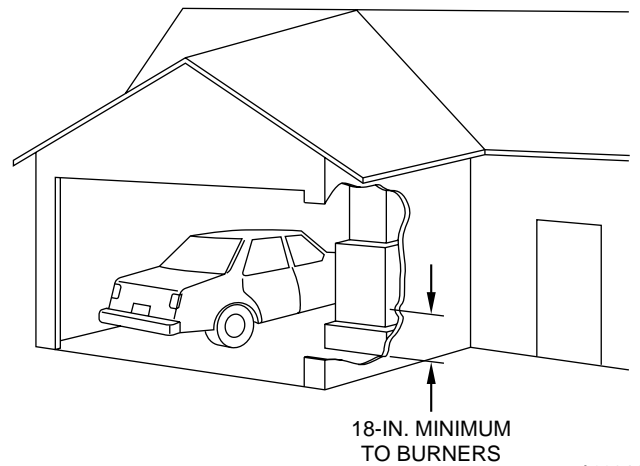

A93044

Fig. 16—Installation in a Garage

WARNING: When furnace is installed in a residential garage, it must be installed so that burners and ignition sources are located a minimum of 18 in. above floor. The furnace must be located or protected to avoid physical damage by vehicles. When furnace is installed in a public garage, airplane hangar, or other building having a hazardous atmosphere, unit must be installed in accordance with requirements of National Fire Protection Association, Inc. (See Fig. 16.)

INSTALLATION

I. LEVELING LEGS (IF DESIRED)

When furnace is used in upflow position with side inlet(s), leveling legs may be desired. (See Fig. 17.) Install field-supplied, corrosion-resistant 5/16-in. machine bolts and nuts.

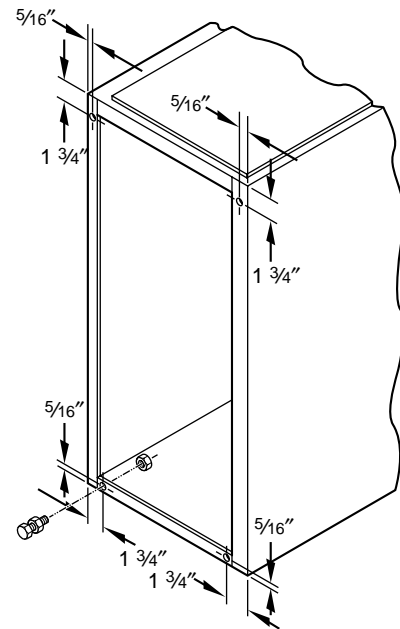

A89014

Fig. 17—Leveling Legs

NOTE: The maximum length of bolt should not exceed 1-1/2 in.

1. Position furnace on its back. Locate and drill a 5/16-in. diameter hole in each bottom corner of furnace. (See Fig. 17.) Holes in bottom closure panel may be used as guide locations.

TABLE 1—OPENING DIMENSIONS (IN.)

| FURNACE CASING WIDTH | APPLICATION | PLENUM OPENING | | FLOOR OPENING | |
|----------------------|---|----------------|--------|---------------|--------|
| | | A | B | C | D |
| 17-1/2 | Upflow Applications | 16 | 24-1/8 | 16-5/8 | 24-3/4 |
| | Downflow Applications on Non-Combustible Flooring | 15-7/8 | 19 | 16-1/2 | 19-5/8 |
| | Downflow Applications on Combustible Flooring Using KGASB Subbase Furnace with or without CD5 or CK5 Coil Assembly or KCAKC Coil Box | 15-1/8 | 19 | 16-3/4 | 20-3/8 |
| | Downflow Applications on Combustible Flooring NOT Using KGASB Subbase Furnace with or without CD5 or CK5 Coil Assembly or KCAKC Coil Box | 15-1/2 | 19 | 16-1/2 | 20 |
| 21 | Upflow Applications | 19-1/2 | 24-1/8 | 20-1/8 | 24-3/4 |
| | Downflow Applications on Non-Combustible Flooring | 19-3/8 | 19 | 20 | 19-5/8 |
| | Downflow Applications on Combustible Flooring Using KGASB Subbase Furnace with or without CD5 or CK5 Coil Assembly or KCAKC Coil Box | 18-5/8 | 19 | 20-1/4 | 20-3/8 |
| | Downflow Applications on Combustible Flooring NOT Using KGASB Subbase Furnace with or without CD5 or CK5 Coil Assembly or KCAKC Coil Box | 19 | 19 | 20 | 20 |
| 24-1/2 | Upflow Applications | 23 | 24-1/8 | 23-5/8 | 24-3/4 |
| | Downflow Applications on Non-Combustible Flooring | 22-7/8 | 19 | 23-1/2 | 19-5/8 |
| | Downflow Applications on Combustible Flooring Using KGASB Subbase Furnace with or without CD5 or CK5 Coil Assembly or KCAKC Coil Box | 22-1/8 | 19 | 23-3/4 | 20-3/8 |
| | Downflow Applications on Combustible Flooring NOT Using KGASB Subbase Furnace with or without CD5 or CK5 Coil Assembly or KCAKC Coil Box | 22-1/2 | 19 | 23-1/2 | 20 |

2. For each hole, install nut on bolt and then install bolt and nut in hole. (Install flat washer if desired.)
3. Install another nut on other side of furnace base. (Install flat washer if desired.)
4. Adjust outside nut to provide desired height, and tighten inside nut to secure arrangement.

NOTE: Bottom closure must be used when leveling legs are used. See Bottom Closure Panel section.

II. INSTALLATION IN UPFLOW AND DOWNFLOW APPLICATIONS

NOTE: For downflow applications, this furnace is approved for use on combustible flooring when special base (available from manufacturer) Part No. KGASB0201ALL is used. Special base is not required when this furnace is installed on manufacturer’s Coil Assembly Part No. CD5 or CK5, or Coil Box Part No. KCAKC is used.

1. Determine application being installed from Table 1.
2. Construct hole in floor per dimensions specified in Table 1 and Fig. 18.
3. Construct plenum to dimensions specified in Table 1 and Fig. 18.
4. If downflow subbase (KGASB) is used, install as shown in Fig. 19.
If Coil Assembly Part No. CD5 or CK5 or Coil Box Part No. KCAKC is used, install as shown in Fig. 20.

NOTE: Remove furnace perforated, discharge duct flanges when they interfere with mating flanges on coil on downflow subbase. To remove furnace perforated, discharge duct flange, use wide duct pliers or duct flange tool to bend flange back and forth until it breaks off. Be careful of sharp edges. (See Fig. 21.)

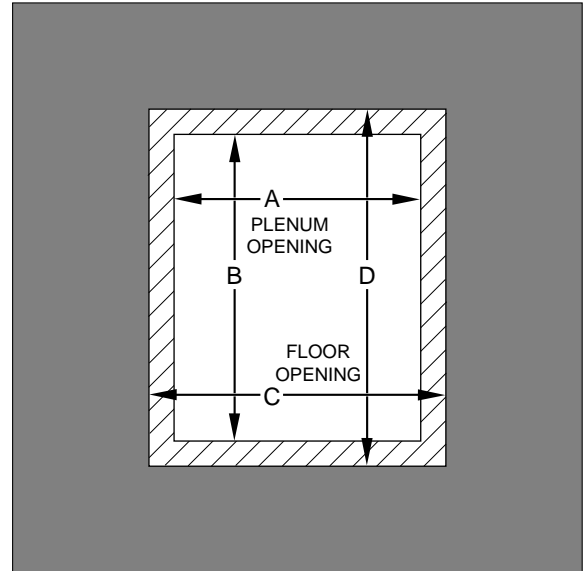

A96283

Fig. 18—Floor and Plenum Opening Dimensions

WARNING: Do not bend duct flanges inward as shown in Fig. 21. This will affect airflow across heat exchangers and may cause limit cycling or premature heat exchanger failure. Remove duct flange completely or bend it inward a minimum of 210° as shown in Fig. 21.

NOTE: For 140 size unit when installed in downflow orientation, cut the white jumper wire off between terminals PLI-6 and PLI-9.

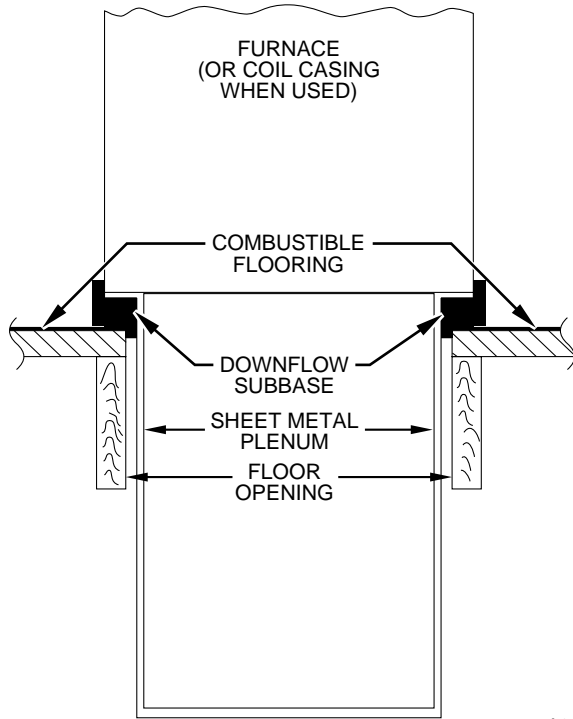

A96285

Fig. 19—Furnace, Plenum, and Subbase Installed on a Combustible Floor

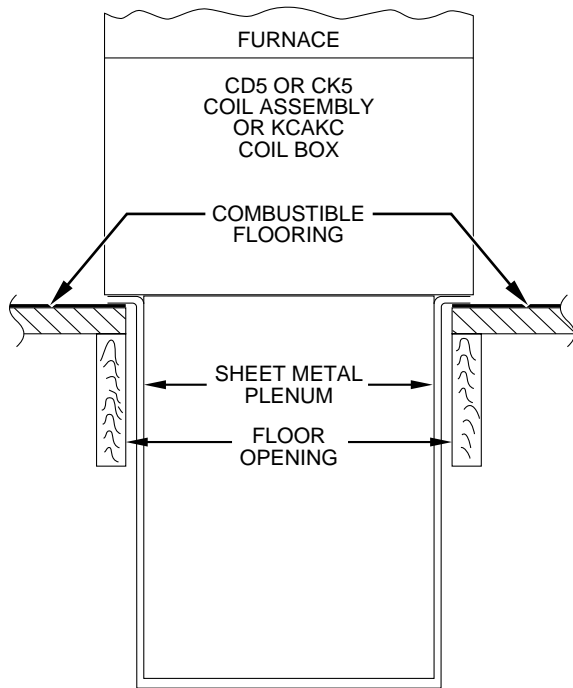

A96284

Fig. 20—Furnace, Plenum, and Coil Assembly or Coil Box Installed on a Combustible Floor

Refer to Fig. 30 for location of jumper. Cut jumper close to connector and remove wire to avoid a short circuit.

III. INSTALLATION IN HORIZONTAL APPLICATIONS

These furnaces can be installed horizontally in either horizontal left or right discharge position. In a crawlspace, furnace can either be hung from floor joist or installed on suitable blocks or pad. Furnace can be suspended from each corner by hanger bolts and angle iron supports. (See Fig. 22.) Cut hanger bolts (4 each 3/8-in. all-thread rod) to desired length. Use 1 X 3/8-in. flat washers, 3/8-in. lock washers, and 3/8-in. nuts on hanger rods as shown in Fig. 22. Dimples are provided for hole locations. (See Fig. 2.)

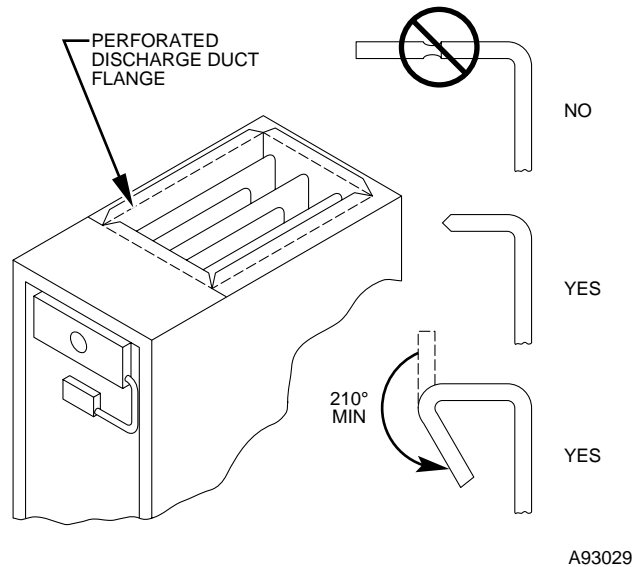

A93029

Fig. 21—Duct Flanges

CAUTION: The entire length of furnace **MUST** be supported when furnace is used in a horizontal position to ensure proper draining. When suspended, bottom brace supports sides and center blower shelf. When unit is supported from the ground, blocks or pad should support sides and center blower shelf area.

IV. AIR DUCTS

A. General Requirements

The duct system should be designed and sized according to accepted national standards such as those published by: Air Conditioning Contractors Association (ACCA), Sheet Metal and Air Conditioning Contractors National Association (SMACNA) or American Society of Heating, Refrigerating and Air Conditioning Engineers (ASHRAE) or consult factory *The Air Systems Design Guidelines* reference tables available from your local distributor. The duct system should be sized to handle the required system design CFM at the design static pressure.

When a furnace is installed so that the supply ducts carry air to areas outside the space containing the furnace, the return air must also be handled by a duct(s) sealed to the furnace casing and terminating outside the space containing the furnace.

Secure ductwork with proper fasteners for type of ductwork used. Seal supply- and return-duct connections to furnace with code approved tape or duct sealer.

Flexible connections should be used between ductwork and furnace to prevent transmission of vibration. Ductwork passing through unconditioned space should be insulated to enhance system performance. When air conditioning is used, a vapor barrier is recommended.

Maintain a 1-in. clearance from combustible materials to supply air ductwork for a distance of 36-in. horizontally from the furnace. See NFPA 90B or local code for further requirements.

B. Ductwork Acoustical Treatment

Metal duct systems that do not have a 90 degree elbow and 10 ft of main duct to the first branch take-off may require internal acoustical lining. As an alternative, fibrous ductwork may be used if constructed and installed in accordance with the latest edition of SMACNA construction 18 standard on fibrous glass ducts. Both acoustical lining and fibrous ductwork shall comply with NFPA 90B as tested by UL Standard 181 for Class 1 Rigid air ducts.

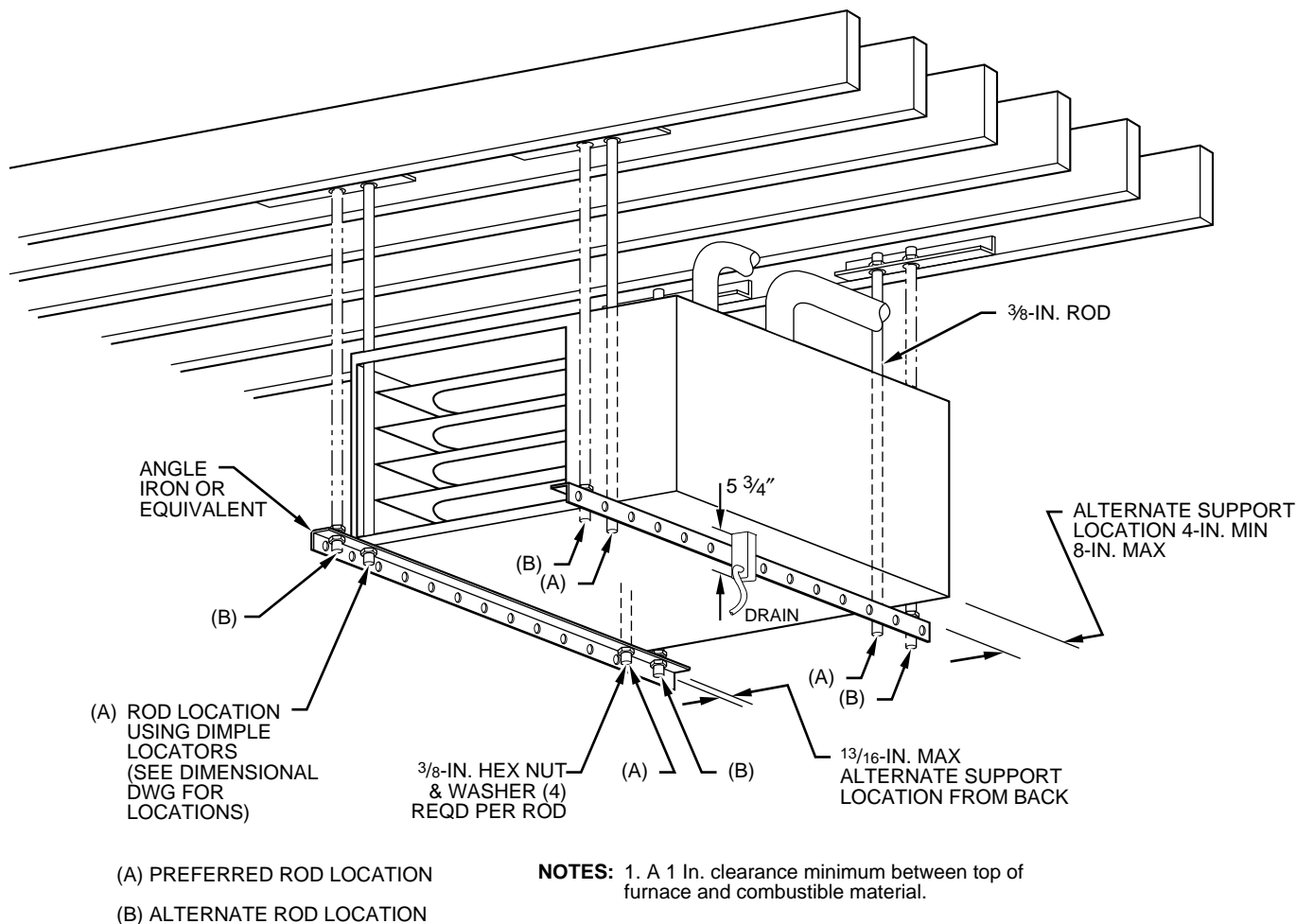

A93304

Fig. 22—Crawlspace Horizontal Application

C. Supply Air Connections

Connect supply-air duct to 3/4-in. flange on furnace supply-air outlet. The supply-air duct attachment must ONLY be connected to furnace supply-/outlet-air duct flanges or air conditioning coil casing (when used). DO NOT cut main furnace casing to attach supply side air duct, humidifier, or other accessories. All accessories MUST be connected external to furnace main casing.

DOWNFLOW FURNACES

Connect supply-air duct to supply-air opening on furnace. The supply-air duct attachment must ONLY be connected to furnace supply/outlet or air conditioning coil casing (when used), when installed on non-combustible material. When installed on combustible material, supply-air duct attachment must ONLY be connected to an accessory subbase or factory approved air conditioning coil casing. DO NOT cut main furnace casing to attach supply side air duct, humidifier, or other accessories. All accessories MUST be connected external to furnace main casing.

HORIZONTAL FURNACES

Connect supply-air duct to supply air opening on furnace. The supply-air duct attachment must ONLY be connected to furnace supply/outlet or air conditioning coil casing (when used). DO NOT cut main furnace casing to attach supply side air duct, humidifier, or other accessories. All accessories MUST be connected external to furnace main casing.

D. Return Air Connections

UPFLOW FURNACES

The return-air duct must be connected to bottom, sides (left or right), or a combination of bottom and side(s) of main furnace casing as shown in Fig. 1. Bypass humidifier may be attached to unused side return air portion of the furnace casing. DO NOT connect any portion of return-air duct to back of furnace casing.

DOWNFLOW AND HORIZONTAL FURNACES

The return-air duct must be connected to return-air opening provided as shown in Fig. 1. DO NOT cut into casing sides or back to attach any portion of return-air duct. Bypass humidifier connections should be made at ductwork or coil casing sides exterior to furnace.

V. FILTER ARRANGEMENT

| | |
|--|---|
| | <p>WARNING: Never operate unit without a filter or with filter access door removed. Failure to follow this warning can cause fire, personal injury, or death</p> |
|--|---|

The air filter arrangement will vary due to application, furnace orientation, and filter type. The filter may be installed in an external Filter/Media cabinet (if provided) or the furnace blower compartment. Factory supplied washable filters are shipped in the blower compartment.

If a factory-supplied external Filter/Media cabinet is provided, instructions for its application, assembly, and installation are packaged with the cabinet. The Filter/Media cabinet can be used with the factory-supplied washable filter or a factory-specified high-efficiency disposable filter (see cabinet instructions).

If installing the filter in the furnace blower compartment, determine location for filter and relocate filter retaining wire if necessary. See Table 2 to determine correct filter size for desired filter location. Table 2 indicates filter size, location, and quantity shipped with this furnace. See Fig. 2 for location and size of bottom and side return-air openings.

TABLE 2—FILTER INFORMATION

| AIR FILTER LOCATED IN BLOWER COMPARTMENT | | | |
|--|----------------------|------------------|-------------|
| FURNACE CASING WIDTH (IN.) | FILTER SIZE (IN.)* | | FILTER TYPE |
| | Side Return | Bottom Return | |
| 17-1/2 | (1) 16 X 25 X 1† | (1) 16 X 25 X 1† | Cleanable |
| 21 | (1) 16 X 25 X 1 | (1) 20 X 25 X 1† | Cleanable |
| 24-1/2 | (1 or 2) 16 X 25 X 1 | (1) 24 X 25 X 1† | Cleanable |

* Filters may be field modified by cutting filter material and support rods (3) in filters. Alternate sizes and additional filters may be ordered from your dealer.
 † Factory-provided with furnace.

CAUTION: Use care when cutting support rods in filters to protect against flying pieces and sharp rod ends. Wear safety glasses, gloves, and appropriate protective clothing. Failure to follow this caution could result in personal injury.

CAUTION: For airflow requirements above 1800 CFM, see Air Delivery table in Product Data literature for specific use of single side inlets. The use of both side inlets, a combination of 1 side and the bottom, or the bottom only will ensure adequate return air openings for airflow requirements above 1800 CFM.

NOTE: Side return-air openings can ONLY be used in UPFLOW configurations. Install filter(s) as shown in Fig. 23. Bottom return-air opening may be used with all 4 orientations. Filter may need to be cut to fit some furnace widths. Install filter as shown in Fig. 24.

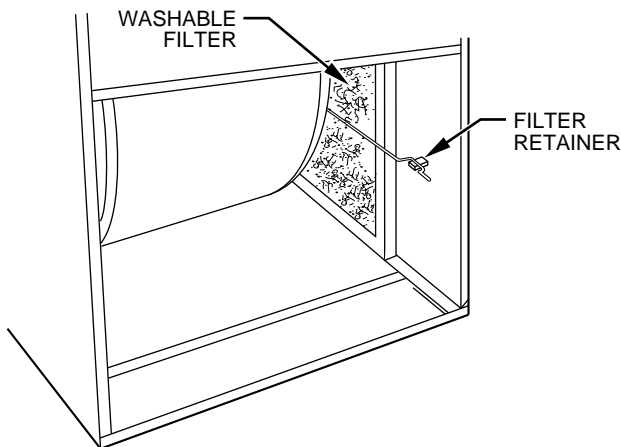

Fig. 23—Filter Installed for Side Inlet

NOTE: Remove and discard bottom closure panel when bottom inlet is used.

17 1/2-IN. WIDE CASINGS ONLY:
 INSTALL FIELD-SUPPLIED FILTER FILLER STRIP UNDER FILTER.

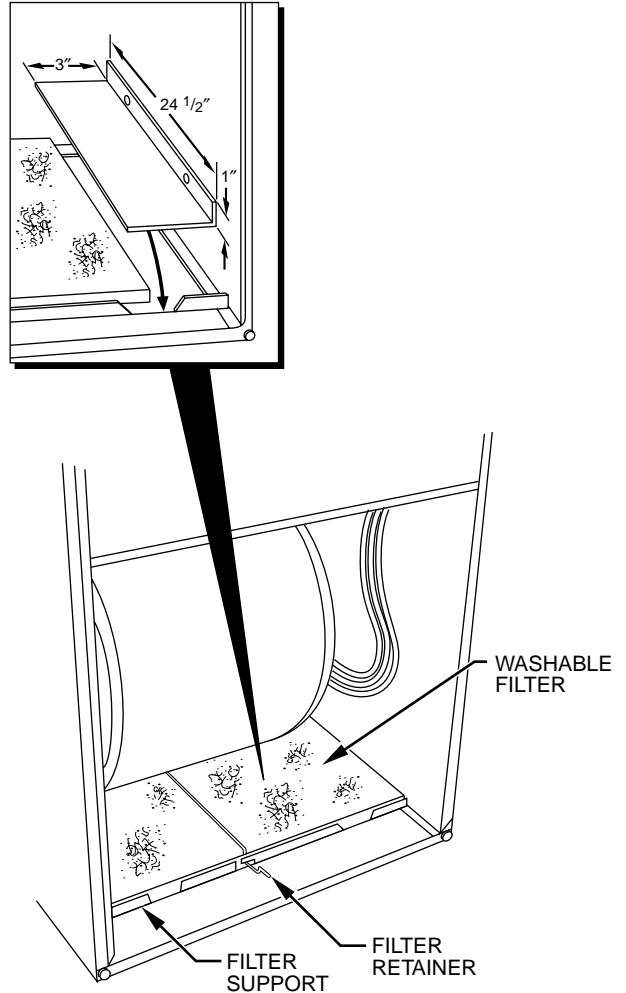

Fig. 24—Bottom Filter Arrangement

A00213

VI. BOTTOM CLOSURE PANEL

These furnaces are shipped with bottom enclosure panel installed in bottom return-air opening. This panel **MUST** be in place when side return air is used.

To remove bottom closure panel, perform following:

1. Tilt or raise furnace and remove 2 screws holding front filler panel. (See Fig. 25.)
2. Rotate front filler panel downward to release holding tabs.
3. Remove bottom closure panel.
4. Reinstall front filler panel and screws.

VII. GAS PIPING

Gas piping must be installed in accordance with national and local codes. Refer to current edition of NFGC. Canadian installations must be made in accordance with NSCNPGIC and all authorities having jurisdiction. Gas supply line should be a separate line running directly from meter to furnace, if possible. Refer to Table 3 for recommended gas pipe sizing. Risers must be used to connect to furnace and to meter. Support all gas piping with appropriate straps, hangers, etc. Use a minimum of 1 hanger every 6 ft. Joint compound (pipe dope) should be applied sparingly and only to male threads of joints. Pipe dope must be resistant to propane gas.

A93045

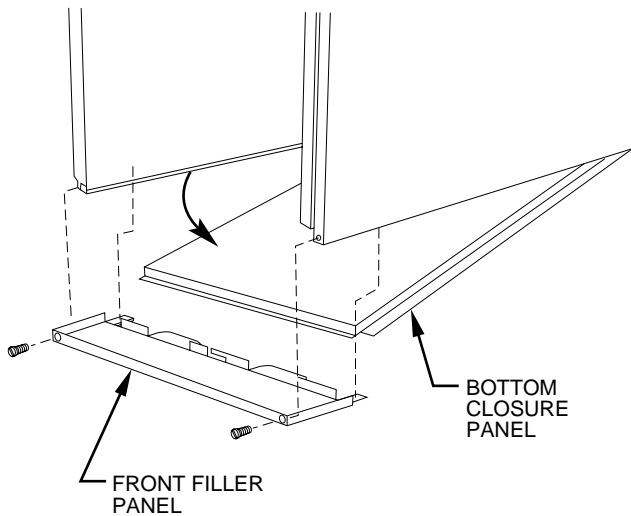

Fig. 25—Removing Bottom Closure Panel

A93047

CAUTION: Connect gas pipe to furnace using a backup wrench to avoid damaging gas controls.

WARNING: Gas valve shutoff switch **MUST** be facing forward or tilted upward. Failure to follow this warning could result in property damage or death.

WARNING: Never purge a gas line into a combustion chamber. Never use matches, candles, flame, or other sources of ignition for purpose of checking leakage. Use a soap-and-water solution to check for leakage. A failure to follow this warning could result in fire, explosion, personal injury, or death.

WARNING: Use proper length of pipe to avoid stress on gas control manifold. Failure to follow this warning could result in a gas leak resulting in fire, explosion, personal injury, or death.

TABLE 3—MAXIMUM CAPACITY OF PIPE*

| NOMINAL IRON PIPE SIZE (IN.) | INTERNAL DIAMETER (IN.) | LENGTH OF PIPE (FT) | | | | |
|------------------------------|-------------------------|---------------------|------|------|-----|-----|
| | | 10 | 20 | 30 | 40 | 50 |
| 1/2 | 0.622 | 175 | 120 | 97 | 82 | 73 |
| 3/4 | 0.824 | 360 | 250 | 200 | 170 | 151 |
| 1 | 1.049 | 680 | 465 | 375 | 320 | 285 |
| 1-1/4 | 1.380 | 1400 | 950 | 770 | 660 | 580 |
| 1-1/2 | 1.610 | 2100 | 1460 | 1180 | 990 | 900 |

* Cubic ft of gas per hr for gas pressures of 0.5 psig (14-in. wc) or less and a pressure drop of 0.5-in wc (based on a 0.60 specific gravity gas). Ref: Table 10-2 NFCC.

Install a sediment trap in riser leading to furnace. Trap can be installed by connecting a tee to riser leading to furnace so straight-through section of tee is vertical. Then connect a capped nipple into lower end of tee. Capped nipple should extend below level of gas controls. Place a ground joint union between gas control manifold and manual gas shutoff valve. (See Fig. 26.)

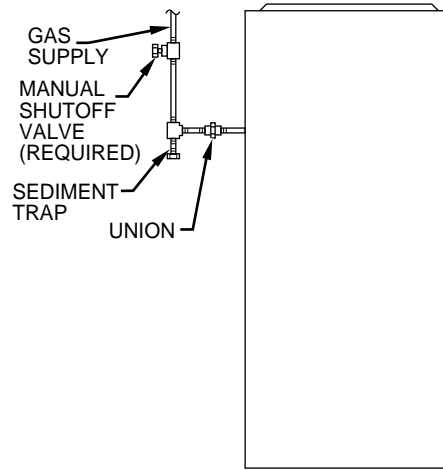

Fig. 26—Typical Gas Pipe Arrangement

A93324

CAUTION: If a flexible connector is required or allowed by authority having jurisdiction, black iron pipe shall be installed at gas valve and extend a minimum of 2 in. outside furnace casing.

An accessible manual shutoff valve **MUST** be installed upstream of furnace gas controls and within 6 ft of furnace. A 1/8-in. NPT plugged tapping, accessible for test gage connection, **MUST** be installed immediately upstream of gas supply connection to furnace and downstream of manual shutoff valve.

NOTE: The gas valve inlet press tap connection is suitable to use as test gage connection providing test pressure **DOES NOT** exceed maximum 0.5 psig (14-in. wc) stated on gas valve. (See Fig. 50.) Piping should be pressure tested in accordance with local and national plumbing and gas codes before furnace is attached. In Canada, refer to current edition of NSCNPIC. If pressure exceeds 0.5 psig (14-in. wc), gas supply pipe must be disconnected from furnace and capped before pressure test. If test pressure is equal to or less than 0.5 psig (14-in. wc), turn off electric shutoff switch located on gas valve before test. It is recommended that ground joint union be loosened before pressure testing. After all connections have been made, purge lines and check for leakage.

VIII. ELECTRICAL CONNECTIONS

See Fig. 27 for field wiring diagram showing typical field 115-v and 24-v wiring. Check all factory and field electrical connections for tightness.

WARNING: Blower access panel door switch opens 115-v power to control center. No component operation can occur. Do not bypass or close switch with panel removed. Failure to follow this warning could result in personal injury or death.

CAUTION: Furnace control must be grounded for proper operation or control will lock out. Control is grounded through green wire routed to gas valve and burner box screw.

A. 115-v Wiring

Before proceeding with electrical connections, make certain that voltage, frequency, and phase correspond to that specified on unit rating plate. Also, check to be sure that service provided by utility

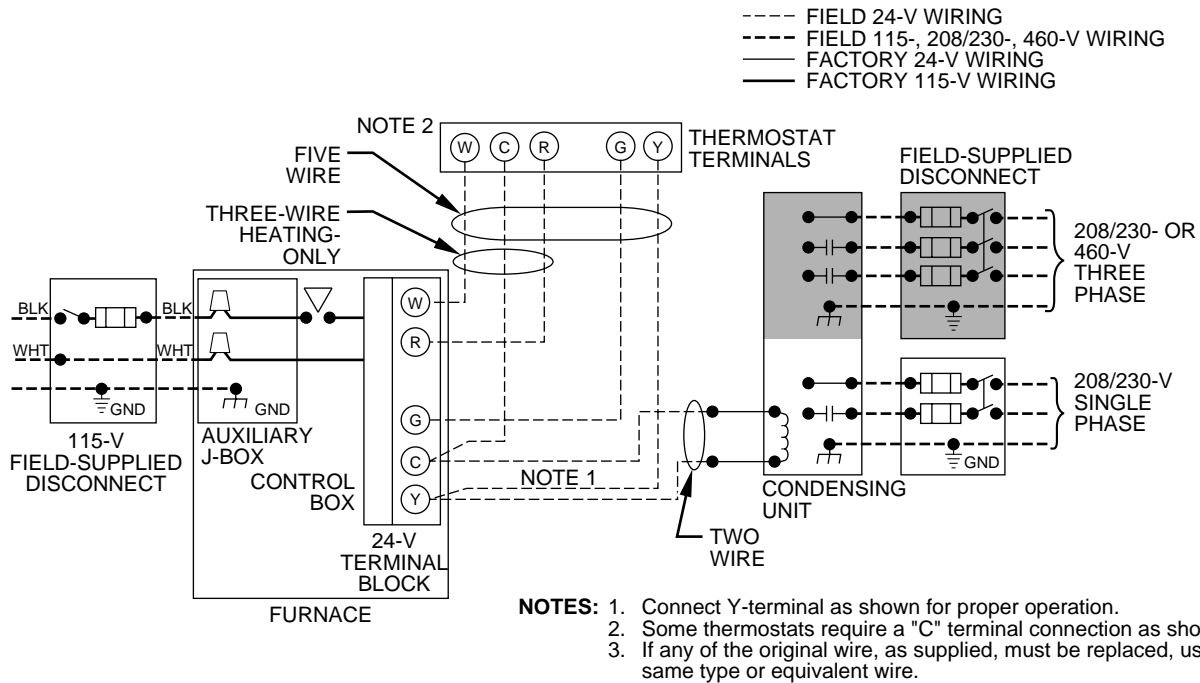

A98209

Fig. 27—Heating and Cooling Application Wiring Diagram

is sufficient to handle load imposed by this equipment. Refer to rating plate or Table 4 for equipment electrical specifications. Make all electrical connections in accordance with National Electrical Code (NEC) ANSI/NFPA 70-1999 and any local codes or ordinances that might apply. For Canadian installations, all electrical connections must be made in accordance with Canadian Electrical Code CSA C22.1 or subauthorities having jurisdiction. Use a separate, fused branch electrical circuit containing a properly sized fuse or circuit breaker for this furnace. See Table 4 for wire size and fuse specifications. A disconnecting means must be located within sight from and readily accessible to furnace.

NOTE: Proper polarity must be maintained for 115-v wiring. If polarity is incorrect, control center LED status indicator light will flash rapidly and furnace will NOT operate.

WARNING: The cabinet MUST have an uninterrupted or unbroken ground according to NEC ANSI/NFPA 70-1999 and Canadian Electrical Code CSA C22.1 or local codes to minimize personal injury if an electrical fault should occur. This may consist of electrical wire or conduit approved for electrical ground when installed in accordance with existing electrical codes. Do not use gas piping as an electrical ground. Failure to follow this warning could result in electrical shock, fire, or death.

J-BOX RELOCATION

1. Remove 2 screws holding auxiliary J-box. (See Fig. 29.)
2. Rotate J-box 180° and attach box to left side, using holes provided.

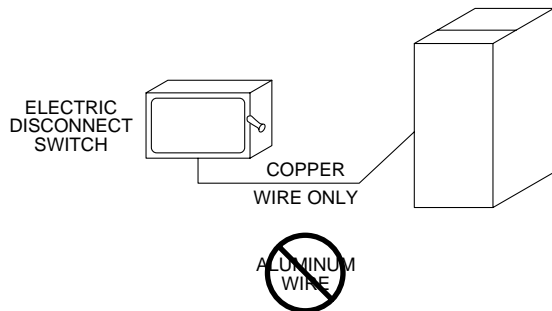

A93033

Fig. 28—Disconnect Switch and Furnace

CAUTION: Do not connect aluminum wire between disconnect switch and furnace. Use only copper wire. (See Fig. 28.)

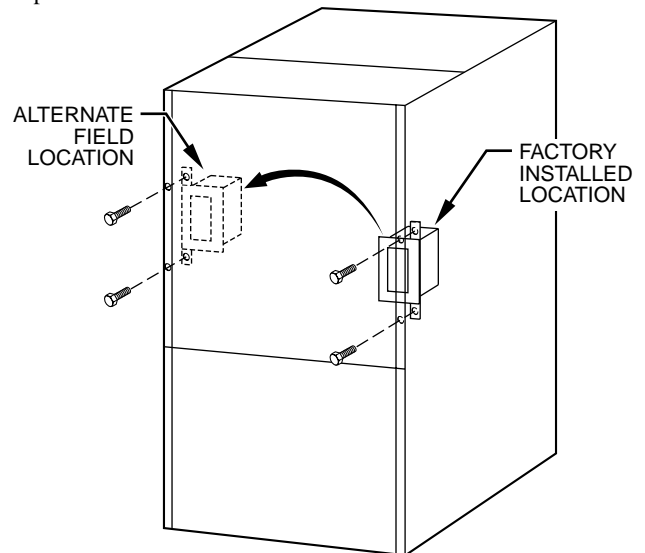

A00212

Fig. 29—Relocating J-Box

TABLE 4—ELECTRICAL DATA

| UNIT SIZE | VOLTS—HERTZ—PHASE | OPERATING VOLTAGE RANGE | | MAX UNIT AMPS | UNIT AMPACITY† | MIN WIRE SIZE | MAX WIRE LENGTH (FT)‡ | MAX FUSE OR CKT BKR AMPS** |
|-----------|-------------------|-------------------------|------|---------------|----------------|---------------|-----------------------|----------------------------|
| | | Max* | Min* | | | | | |
| 024040 | 115-60-1 | 127 | 104 | 6.1 | 8.4 | 14 | 44 | 15 |
| 036040 | 115-60-1 | 127 | 104 | 7.3 | 10.0 | 14 | 37 | 15 |
| 024060 | 115-60-1 | 127 | 104 | 6.1 | 8.4 | 14 | 44 | 15 |
| 036060 | 115-60-1 | 127 | 104 | 7.1 | 9.8 | 14 | 38 | 15 |
| 048060 | 115-60-1 | 127 | 104 | 9.5 | 12.8 | 14 | 29 | 15 |
| 036080 | 115-60-1 | 127 | 104 | 7.6 | 10.4 | 14 | 36 | 15 |
| 048080 | 115-60-1 | 127 | 104 | 10.0 | 13.4 | 14 | 28 | 15 |
| 060080 | 115-60-1 | 127 | 104 | 14.1 | 18.4 | 12 | 31 | 20 |
| 048100 | 115-60-1 | 127 | 104 | 10.2 | 13.5 | 14 | 27 | 15 |
| 060100 | 115-60-1 | 127 | 104 | 14.8 | 19.3 | 12 | 30 | 20 |
| 060120 | 115-60-1 | 127 | 104 | 14.6 | 19.1 | 12 | 30 | 20 |
| 060140 | 115-60-1 | 127 | 104 | 14.3 | 18.8 | 12 | 30 | 20 |

* Permissible limits of voltage range at which unit will operate satisfactorily.

† Unit ampacity = 125 percent of largest operating component's full load amps plus 100 percent of all other potential operating components' (EAC, humidifier, etc.) full load amps.

‡ Length shown is a measured 1 way along wire path between unit and service panel for maximum 2 percent voltage drop.

** Time-delay type is recommended.

CAUTION: If manual disconnect switch is to be mounted on furnace, select a location where a drill or fastener will not contact electrical or gas components.

B. 24-v Wiring

Make field 24-v thermostat connections at 24-v terminal block on control center. For proper cooling operation, Y wire from thermostat MUST be connected to Y terminal on control center, as shown in Fig. 27. The 24-v terminal board is marked for easy connection of field wiring. (See Fig. 30.) The 24-v circuit contains a 3-amp, automotive-type fuse located on control center. (See Fig. 31.) Any electrical shorts of 24-v wiring during installation, service, or maintenance may cause fuse to blow. If fuse replacement is required, use only a fuse of identical size (3 amp).

NOTE: Use AWG No. 18 color-coded copper thermostat wire for lengths up to 100 ft. For wire lengths over 100 ft, use AWG No. 16 wire.

C. Accessories

1. Electronic Air Cleaner (EAC)
Two quick-connect terminals marked EAC-1 and EAC-2 are provided for EAC connection. (See Fig. 31.) These terminals are energized with 115-v (1.5-amp maximum) during blower motor operation.
2. Humidifier (HUM)
A quick-connect terminal (HUM) and screw terminal (COM) are provided for 24-v humidifier connection. (See Fig. 30.) HUM terminal is energized with 24-v (0.5-amp maximum) after inducer pressure switch closes.

NOTE: A field-supplied, 115-v controlled relay connected to EAC terminals may be added if humidifier operation is desired during blower operation.

IX. DIRECT VENTING

The 350MAV Furnaces require a dedicated (one 350MAV furnace only) direct-vent system. In a direct-vent system, all air for combustion is taken directly from outside atmosphere, and all flue products are discharged to outside atmosphere.

A. Removal of Existing Furnaces from Common Vent Systems

If furnace being replaced was connected to a common vent system with other appliances, the following steps shall be followed with each appliance connected to the venting system placed in operation, while any other appliances connected to the venting system are not in operation:

1. Seal any unused openings in the venting system.
2. Inspect the venting system for proper size and horizontal pitch as required in the National Fuel Gas Code, ANSI Z223.1 or 24 CAN/CGA B149 Installation Codes and these instructions. Determine that there is no blockage or restriction, leakage, corrosion, and other deficiencies which could cause an unsafe condition.
3. In so far as is practical, close all building doors and windows and all doors between the space in which the appliance(s) connected to the venting system are located and other spaces of the building. Turn on clothes dryers and any appliance not connected to the venting system. Turn on any exhaust fans, such as range hoods and bathroom exhausts, so they shall operate at maximum speed. Do not operate a summer exhaust fan. Close fireplace dampers.
4. Follow the lighting instructions. Place the appliance being inspected in operation. Adjust thermostat so appliance shall operate continuously.
5. Test for draft hood equipped appliance spillage at the draft hood relief opening after 5 minutes of main burner operation. Use the flame of a match or candle.
6. After it has been determined that each appliance connected to the venting system properly vents when tested as outlined above, return doors, windows, exhaust fans, fireplace dampers, and any other gas-burning appliance to their previous conditions of use.
7. If improper venting is observed during any of above tests, the venting system must be corrected.

Vent system or vent connectors may need to be resized. For any other appliances when resizing vent systems or vent connectors, system or connector must be sized to approach minimum size as determined using appropriate table found in the NFGC or NSC-NGPIC.

B. Combustion-Air and Vent Piping

GENERAL

→ Combustion-air and vent pipe, fittings, primers, and solvents must conform to American Standards Institute (ANSI) standards and American Society for Testing and Materials (ASTM) standards. See Table 5 for approved materials for use in the U.S.A. and Canada. In Canada construct all combustion-air and vent pipes for this unit of CSA or ULC certified schedule-40 PVC, PVC-DWV or ABS-DWV pipe and pipe cement. SDR pipe is NOT approved in Canada.

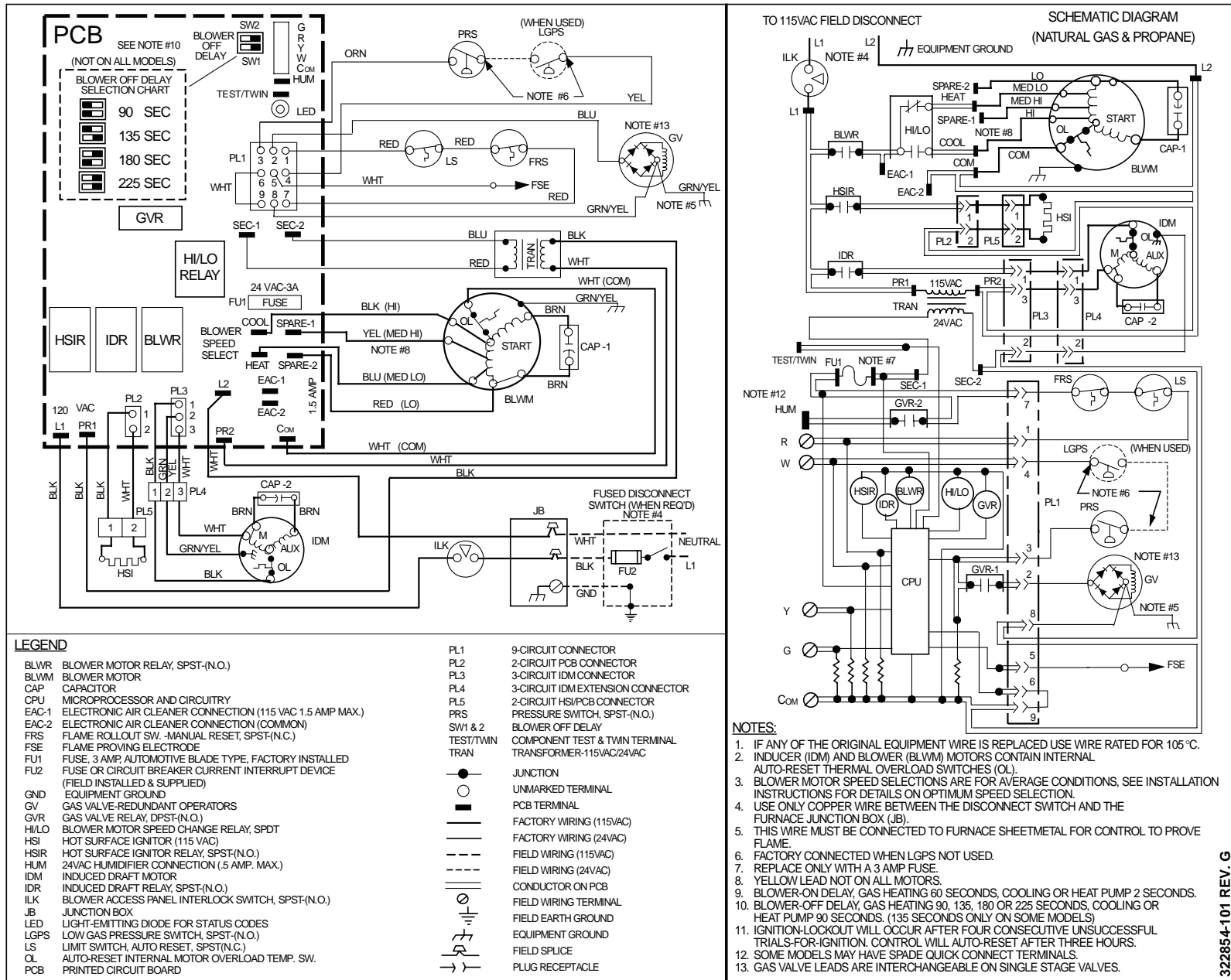
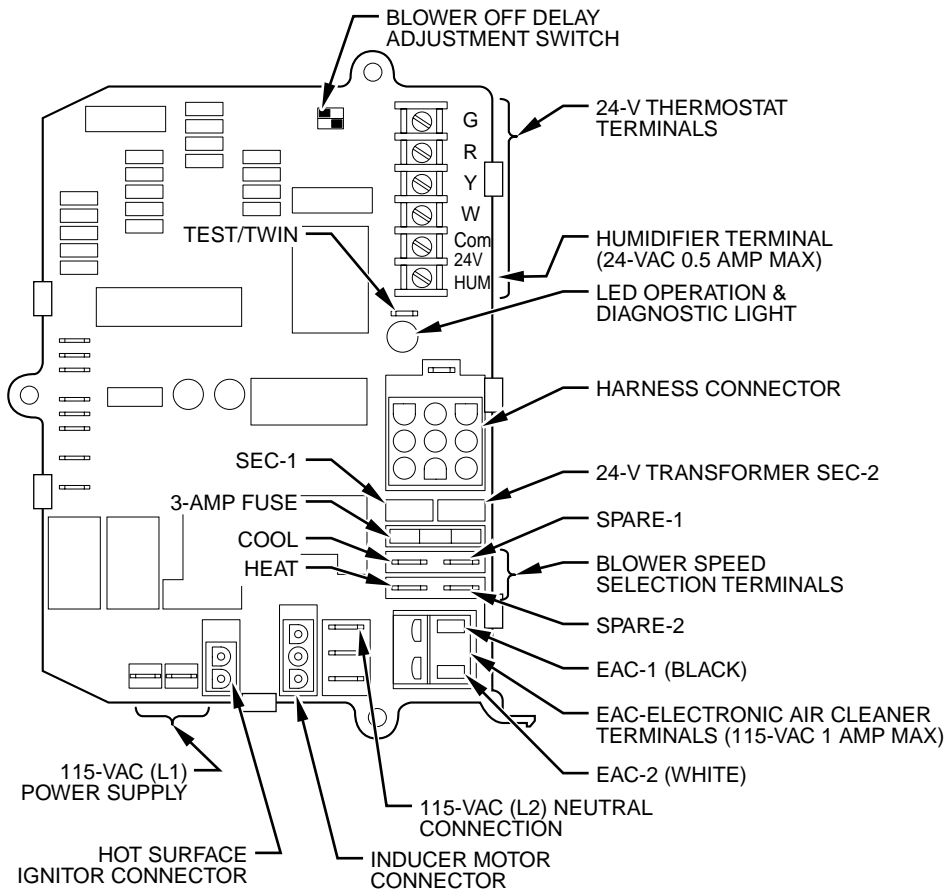

Fig. 30—Wiring Diagram



A00292

Fig. 31—Control Center

See Table 7 for maximum pipe lengths and Fig. 36, 37, 38, 39, and 40 for exterior piping arrangements.

NOTE: Furnace combustion-air and vent pipe connections are sized for 2-in. pipe. Any pipe size change should be made outside furnace casing in vertical pipe. (See Fig. 32.) This allows proper drainage of vent condensate.

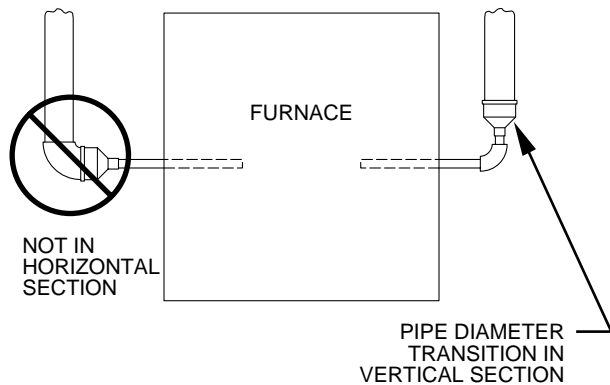

A93034

Fig. 32—Combustion-Air and Vent Pipe Diameter Transition Location and Elbow Configuration

Combustion-air and vent pipes must terminate together in same atmosphere pressure zone, either through roof or sidewall (roof termination preferred), using accessory termination kit. See Table 5 for required clearances.

Furnace combustion-air and vent pipe connections must be attached as shown in Fig. 33. Combustion-air intake plug fitting and inducer housing alternate vent cap may need to be relocated in some applications.

NOTE: Slope combustion-air and vent pipes a minimum of 1/4-in. per linear ft with no sags between hangers.

| | |
|---|--|
| ⚠ | <p>CAUTION: When combustion-air pipe is installed above a suspended ceiling, pipe must be insulated with 3/8-in. thick Armaflex-type insulation. Combustion-air pipe should also be insulated when it passes through warm, humid space.</p> |
|---|--|

→ An abandoned masonry chimney may be used as a raceway for properly insulated and supported combustion-air and vent pipes. Each furnace must have its own set of combustion-air and vent pipes and be terminated individually, as shown in Fig. 42.

→ Other gas appliances with their own venting system may also use the abandoned chimney as a raceway providing it is permitted by local code, the current edition of the National Fuel Gas Code and the vent or liner manufacturer's Installation Instructions. Care must be taken to prevent the exhaust gases from one appliance from contaminating the combustion air of other gas appliances.

| | |
|---|---|
| ⚠ | <p>CAUTION: When vent pipe is exposed to temperatures below freezing, such as when it passes through an unheated space or when a chimney is used as a raceway, pipe must be insulated as shown in Table 8 with Armaflex-type insulation.</p> |
|---|---|

TABLE 5—COMBUSTION-AIR AND VENT PIPE TERMINATION CLEARANCES

| LOCATION | CLEARANCE (FT) | |
|---|----------------|--------|
| | U.S.A. | Canada |
| Above grade level or above anticipated snow depth | 1 | 1† |
| Dryer/Water heat vent | 3 | 3 |
| From plumbing vent stack | 3 | 3 |
| From any mechanical fresh air intake | Note 4 | 6 |
| For furnaces with an input capacity of 100,000 Btuh or less—from any non-mechanical air supply (windows or doors which can be opened) or combustion-air opening | 1 | 1 |
| For furnaces with an input capacity greater than 100,000 Btuh or less—from any non-mechanical air supply (windows or doors which can be opened) or combustion-air opening | 1 | 3 |
| From service regulator vent, electric and gas meters and relief equipment | 4* | 6‡ |
| Above grade when adjacent to public walkway | Note 3 | Note 3 |

* Horizontal distance.
 † 18 in. above roof surface in Canada.
 ‡ 36 in. to electric meter in Canada only.

NOTES:

1. If installing 2 adjacent 350MAV Furnaces, refer to Multiventing and Vent Terminations section for proper vent configurations.
2. When locating combustion-air and vent terminations, consideration must be given to prevailing winds, location, and other conditions which may cause recirculation of the appliance's own flue products or the flue products of adjacent vents. Recirculation can cause poor combustion, inlet condensate problems, and accelerated corrosion of heat exchangers.
3. Vent termination can not terminate less than 2 ft horizontal and 7 ft above public walkway or where condensate vapor or droplets may be a hazard.
4. Vent termination must be at least 3 feet above any forced draft inlets within 10 feet horizontal. Vent termination must be at least 3 feet horizontal from other direct vent appliances intake unless otherwise specified by manufacturer.

NOTE: Select 1 vent pipe connection and 1 combustion-air pipe connection.

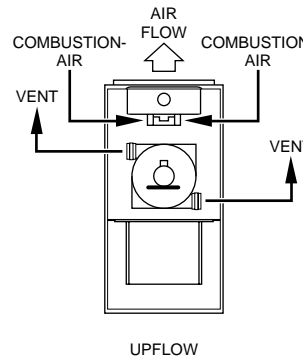

NOTE: Select 1 vent pipe connection and 1 combustion-air pipe connection.

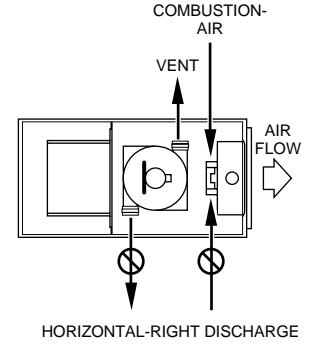
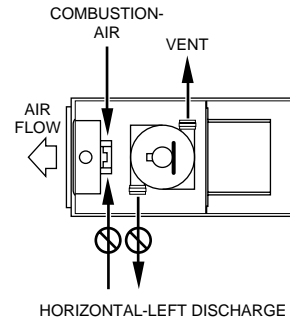
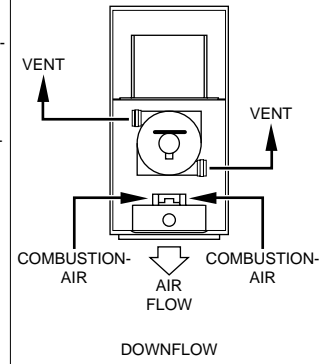

A96187

Fig. 33—Combustion-Air and Vent Pipe Connections

TABLE 6—APPROVED COMBUSTION-AIR AND VENT PIPE, FITTING AND CEMENT MATERIALS

| SPECIFICATION (MARKED ON MATERIAL) | MATERIAL | PIPE | FITTINGS | SOLVENT CEMENT AND PRIMERS | DESCRIPTION |
|------------------------------------|----------|------|----------|----------------------------|--|
| D1527 | ABS | Pipe | — | — | Schedule-40 |
| D1785 | PVC | Pipe | — | — | Schedule-40 |
| D2235 | For ABS | — | — | Solvent Cement | For ABS |
| D2241 | PVC | Pipe | — | — | SDR-21 & SDR-26 |
| D2466 | PVC | — | Fittings | — | Schedule-40 |
| D2468 | ABS | — | Fittings | — | Schedule-40 |
| D2564 | For PVC | — | — | Solvent Cement | For PVC |
| D2661 | ABS | Pipe | Fittings | — | DWV at Schedule-40 IPS sizes |
| D2665 | PVC | Pipe | Fittings | — | DWV |
| F438 | CPVC | — | Fittings | — | Schedule-40 |
| F441 | CPVC | Pipe | — | — | Schedule-40 |
| F442 | CPVC | Pipe | — | — | SDR |
| F493 | For CPVC | — | — | Solvent Cement | For CPVC |
| F628 | ABS | Pipe | — | — | Cellular Core DWV at Schedule-40 IPS sizes |
| F656 | For PVC | — | — | Primer | For PVC |
| F891 | PVC | Pipe | — | — | Cellular Core Schedule-40 & DWV |

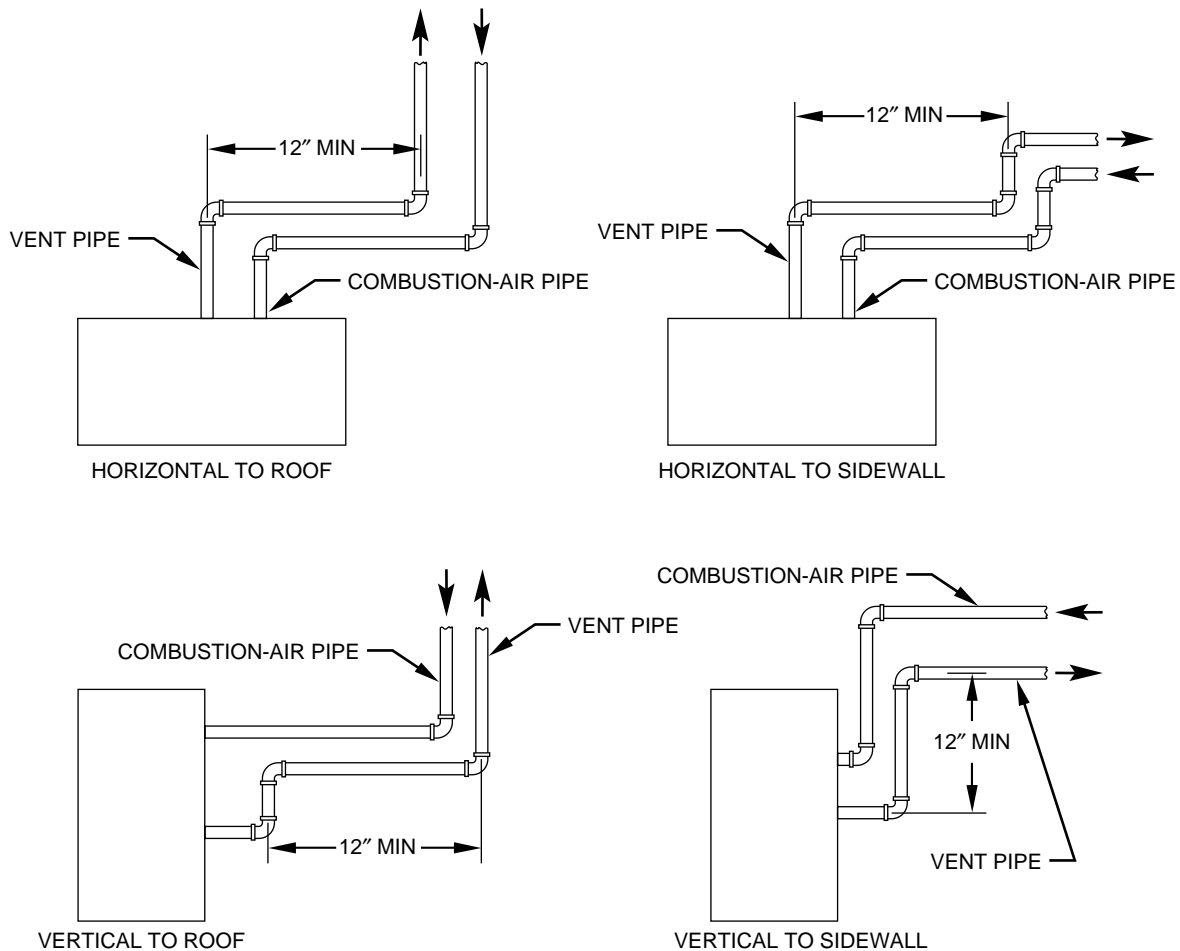

NOTE: A 12 in. minimum offset pipe section is recommended with short (5 to 8 ft) vent systems. This recommendation is to reduce excessive condensate droplets from exiting the vent pipe.

A96230

Fig. 34—Short Vent (5 to 8 Ft) System

CAUTION: Combustion air must not be taken from inside structure because inside air is frequently contaminated by halogens, which include fluorides, chlorides, bromides, and iodides. These elements are found in aerosols, detergents, bleaches, cleaning solvents, salts, air fresheners, adhesives, paint, and other household products. Locate combustion-air inlet as far as possible from swimming pool and swimming pool pump house. Excessive exposure to contaminated combustion air will result in safety and performance related problems.

WARNING: Solvent cements are combustible. Keep away from heat, sparks, and open flame. Use only in well-ventilated areas. Avoid breathing in vapor or allowing contact with skin or eyes. Failure to follow this warning could result in fire, property damage, personal injury, or death.

WARNING: All combustion-air and vent pipes must be airtight and watertight. Pipes must also terminate exactly as shown in Fig. 36, 37, 38, 39, or 40. Failure to follow this warning could result in property damage, personal injury, or death.

NOTE: The minimum combustion-air and vent pipe length (each) for these furnaces is 5 ft. Short pipe lengths (5-8 ft) may discharge water droplets. These droplets may be undesirable, and a 12-in. minimum offset pipe section is recommended, as shown in Fig. 34, to reduce excessive droplets from exiting vent pipe outlet.

COMBUSTION-AIR AND VENT PIPE DIAMETER

Determine combustion-air and vent pipe diameter.

1. Using Table 7, individually determine the combustion-air and vent pipe diameters. Pick the larger of these 2 pipe diameters and use this diameter for both combustion-air and vent pipes.
2. When installing vent systems of short pipe length, use the smallest allowable pipe diameter. Do not use pipe size greater than required or incomplete combustion, flame disturbance, or flame sense lockout may occur.

NOTE: Do not count elbows or pipe sections in terminations or within furnace. See shaded areas in Fig. 36, 37, 38, 39, and 40.

EXAMPLE: An 036080 size furnace located in Indianapolis, elevation 650 ft above sea level, could be installed in an application requiring 3 elbows and 32 ft of vent pipe, along with 5 elbows and 34 ft of combustion-air pipe. Table 6 indicates this application would allow a 2-in. diameter vent pipe, but require a 2-1/2 in. diameter combustion air pipe (2-in. pipe is good for 35 ft with 3 elbows, but only 30 ft with 5 elbows). Therefore, 2-1/2 in. diameter pipe must be used for both vent and combustion-air pipes since larger required diameter must always be used for both pipes. If same installation were in Albuquerque, elevation 5250 ft above sea level, installation would require 2-1/2 in. vent pipe and combustion-air pipe. At 5001- to 6000-ft elevation, 2-in. pipe is only good for 17 ft with 5 elbows, and 2-1/2 in. pipe is good for 70 ft with 5 elbows.

COMBUSTION-AIR AND VENT PIPE ATTACHMENT

NOTE: All pipe joints must be watertight except attachment of combustion-air pipe to inlet housing connection, since it may be necessary to remove pipe for servicing.

1. Attach combustion-air pipe as follows:
 - a. Determine location of combustion-air intake pipe connection to combustion-air intake housing as shown in Fig. 33 for application.
 - b. Reposition combustion-air intake housing plug fitting in appropriate unused intake housing connection.
 - c. If required, insert perforated disk assembly (factory-supplied in loose parts bag) in intake housing where combustion-air intake pipe will be connected. If half disk set is required, install with shoulder of disk against stop in combustion-air inlet.
 - d. Install pipe support (factory-supplied in loose parts bag) into selected furnace casing combustion-air pipe hole. Pipe support should be positioned at bottom of casing hole.
 - e. Insert 2-in. diameter pipe into intake housing.

NOTE: A 2-in. diameter pipe must be used within the furnace casing. Make all pipe diameter transitions outside furnace casing.

- f. Install casing hole filler cap (factory-supplied in loose parts bag) in unused combustion-air pipe casing hold.
- g. Drill a 1/8-in. hole in 2-in. combustion-air pipe using hole in intake housing as a guide.
- h. Install a field-supplied No. 6 or No. 8 sheet metal screw into combustion-air pipe.

NOTE: DO NOT OVERTIGHTEN SCREW. Breakage to intake housing or fitting may cause air leakage to occur.

NOTE: Do not attach combustion-air intake pipe permanently to combustion-air intake housing since it may be necessary to remove pipe for service of ignitor or flame sensor.

COMBUSTION-AIR INTAKE HOUSING PLUG FITTING

The combustion-air intake plug fitting must be installed in unused combustion-air intake housing. This fitting must be attached by using RTV sealant, or by drilling a 1/8-in. hole in fitting, using hole in intake housing as a guide. Install a field-supplied No. 6 or No. 8 sheet metal screw.

NOTE: DO NOT OVERTIGHTEN SCREW. Breakage to intake housing or fitting may cause air leakage to occur.

A plugged drain connection has been provided on this fitting for use when moisture is found in combustion-air intake pipe and combustion box.

NOTE: Moisture in combustion-air intake may be result of improper termination. Ensure combustion-air intake pipe is similar to that shown in Fig. 36, 37, 38, 39, and 40 so it will not be susceptible to areas where light snow or other sources of moisture could be pulled in.

If use of this drain connection is desired, drill out fitting's tap plug with a 3/16-in. drill and connect a field-supplied 3/8-in. tube. This tube should be routed to open condensate drain for furnace and A/C (if used), and should be trapped. (See Fig. 35.)

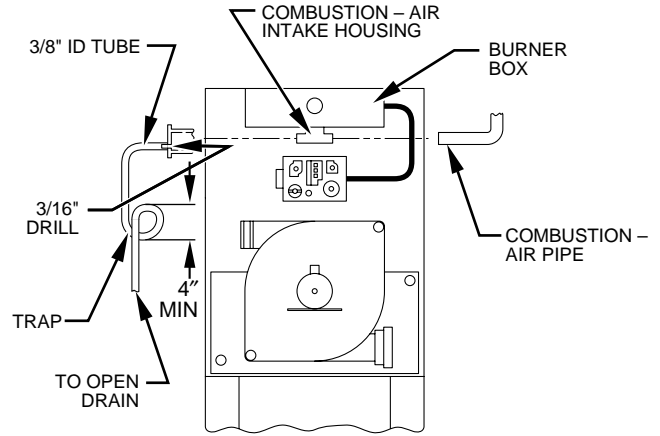

A93035

Fig. 35—Intake Housing Plug Fitting Drain

2. Attach vent pipe as follows:
 - a. Determine location of vent pipe connection to inducer housing as shown in Fig. 33 for application.
 - b. Reposition elastomeric (rubber) inducer housing outlet cap and clamp to appropriate unused inducer housing connection. Tighten clamp.

WARNING: Inducer housing outlet cap must be installed and fully seated against inducer housing. Clamp must be tightened to prevent any condensate leakage. Failure to follow this warning could result in electrical shock, fire, personal injury, or death.

- c. Install pipe support (factory-supplied in loose parts bag) into selected furnace casing vent pipe hole. Pipe support should be positioned at bottom of casing hole.
- d. Be certain that mating surfaces of inducer housing connection, elastomeric coupling, and 2-in. diameter vent pipe are clean and dry. Assemble the elastomeric (rubber) vent coupling (with 2 loose clamps) onto inducer housing connection. Insert the 2-in. diameter vent pipe through the elastomeric (rubber) coupling and fully into inducer housing connection until it bottoms on the internal stop. Tighten both clamps to secure the pipe to inducer housing. Tighten the clamp screws to 15 in.-lb. of torque.
- e. Install casing hole filler cap (factory-supplied in loose parts bag) in unused combustion-air pipe casing hold.

WARNING: Vent pipe must be installed and fully seated against inducer housing internal stop. Clamp must be tightened to prevent any condensate leakage. Failure to follow this warning could result in electrical shock, fire, personal injury, or death.

NOTE: A 2-in. diameter pipe must be used within the furnace casing. Make all pipe diameter transitions outside furnace casing.

TABLE 7—MAXIMUM ALLOWABLE PIPE LENGTH (FT)

| ALTITUDE (FT) | UNIT SIZE | TERMINATION TYPE | PIPE DIA (IN.)* | NUMBER OF 90° ELBOWS | | | | | | |
|---------------|----------------------------|----------------------------|-----------------|----------------------|----|----|----|----|----|----|
| | | | | 1 | 2 | 3 | 4 | 5 | 6 | |
| 0 to 2000 | 024040 036040 | 2 Pipe or 2-in Concentric | 1 | 5 | NA | NA | NA | NA | NA | NA |
| | | | 1-1/2 | 70 | 70 | 65 | 60 | 60 | 55 | |
| | | | 2 | 70 | 70 | 70 | 70 | 70 | 70 | |
| | 024060 036060 048060 | 2 Pipe or 2-in Concentric | 1-1/2 | 20 | 15 | 10 | 5 | NA | NA | |
| | | | 2 | 70 | 70 | 70 | 70 | 70 | 70 | |
| | 036080 048060 060080 | 2 Pipe or 2-in Concentric | 1-1/2 | 10 | NA | NA | NA | NA | NA | |
| | | | 2 | 55 | 50 | 35 | 30 | 30 | 20 | |
| | | | 2-1/2 | 70 | 70 | 70 | 70 | 70 | 70 | |
| | 048100 060100 | 2 Pipe or 3-in Concentric | 2 | 5 | NA | NA | NA | NA | NA | |
| | | | 2-1/2 | 40 | 30 | 20 | 20 | 10 | NA | |
| | | | 3 | 70 | 70 | 70 | 70 | 70 | 70 | |
| | 060120 | 2 Pipe or 3-in. Concentric | 2-1/2 one disk | 10 | NA | NA | NA | NA | NA | |
| | | | 3† | 45 | 40 | 35 | 30 | 25 | 20 | |
| | | | 3† no disk | 70 | 70 | 70 | 70 | 70 | 70 | |
| 060140 | 2 Pipe or 3-in. Concentric | 4† no disk | 70 | 70 | 70 | 70 | 70 | 70 | | |
| | | 2-1/2 one disk | 5 | NA | NA | NA | NA | NA | | |
| | | 3† one disk | 40 | 35 | 30 | 25 | 20 | 15 | | |
| | | | 3† no disk | 60 | 56 | 52 | 48 | 44 | 40 | |
| | | | 4† no disk | 70 | 70 | 70 | 70 | 70 | 70 | |
| | | | | | | | | | | |
| ALTITUDE (FT) | UNIT SIZE | TERMINATION TYPE | PIPE DIA (IN.)* | NUMBER OF 90° ELBOWS | | | | | | |
| 2001 to 3000 | 024040 036040 | 2 Pipe or 2-in Concentric | 1-1/2 | 67 | 62 | 57 | 52 | 52 | 47 | |
| | | | 2 | 70 | 70 | 70 | 70 | 70 | 70 | |
| | | | 1-1/2 | 17 | 12 | 7 | NA | NA | NA | |
| | 024060 036060 048060 | 2 Pipe or 2-in Concentric | 2 | 70 | 67 | 66 | 61 | 61 | 61 | |
| | | | | | | | | | | |
| | 036080 048080 060080 | 2 Pipe or 2-in Concentric | 2 | 49 | 44 | 30 | 25 | 25 | 15 | |
| | | | 2-1/2 | 70 | 70 | 70 | 70 | 70 | 70 | |
| | 048100 060100 | 2 Pipe or 3-in Concentric | 2-1/2 | 35 | 26 | 16 | 16 | 6 | NA | |
| | | | 3 | 70 | 70 | 70 | 70 | 66 | 61 | |
| | 060120 | 2 Pipe or 3-in. Concentric | 3 | 14 | 9 | NA | NA | NA | NA | |
| | | | 3† no disk | 70 | 70 | 63 | 56 | 50 | 43 | |
| | | | 4† no disk | 70 | 70 | 70 | 70 | 70 | 70 | |
| | 060140 | 2 Pipe or 3-in. Concentric | 3† one disk | 20 | 15 | 10 | 5 | NA | NA | |
| | | | 3† no disk | 39 | 35 | 31 | 27 | 23 | 19 | |
| 4† no disk | | | 70 | 70 | 70 | 70 | 70 | 70 | | |
| | | | | | | | | | | |
| ALTITUDE (FT) | UNIT SIZE | TERMINATION TYPE | PIPE DIA (IN.)* | NUMBER OF 90° ELBOWS | | | | | | |
| 3001 to 4000 | 024040 036040 | 2 Pipe or 2-in Concentric | 1-1/2 | 64 | 59 | 54 | 49 | 48 | 43 | |
| | | | 2 | 70 | 70 | 70 | 70 | 70 | 70 | |
| | 024060 036060 048060 | 2 Pipe or 2-in Concentric | 1-1/2 | 16 | 11 | 6 | NA | NA | NA | |
| | | | 2 | 68 | 63 | 62 | 57 | 57 | 56 | |
| | 036080 048080 060080 | 2 Pipe or 2-in Concentric | 2 | 46 | 41 | 28 | 23 | 22 | 13 | |
| | | | 2-1/2 | 70 | 70 | 70 | 70 | 70 | 70 | |
| | 048100 060100 | 2 Pipe or 3-in Concentric | 2-1/2 | 33 | 24 | 15 | 14 | 5 | NA | |
| | | | 3 | 70 | 70 | 70 | 66 | 61 | 56 | |
| | 060120 | 2 Pipe or 3-in. Concentric | 3† no disk | 65 | 58 | 51 | 44 | 38 | 31 | |
| | | | 4† no disk | 70 | 70 | 70 | 70 | 70 | 70 | |
| | 060140 | 2 Pipe or 3-in. Concentric | 3† one disk | 11 | 6 | NA | NA | NA | NA | |
| | | | 3† no disk | 30 | 26 | 22 | 18 | 14 | 10 | |
| | | | 4† no disk | 70 | 70 | 70 | 70 | 70 | 70 | |

TABLE 7—MAXIMUM ALLOWABLE PIPE LENGTH (FT) (CONTINUED)

| ALTITUDE (FT) | UNIT SIZE | TERMINATION TYPE | PIPE DIA (IN.)* | NUMBER OF 90° ELBOWS | | | | | | |
|---------------|----------------------------|-------------------------------|------------------|----------------------|----------------------|----|----|----|----|--|
| | | | | 1 | 2 | 3 | 4 | 5 | 6 | |
| 4001 to 5000‡ | 024040 036040 | 2 Pipe or 2-in Concentric | 1-1/2 | 60 | 55 | 50 | 45 | 44 | 39 | |
| | | | 2 | 70 | 70 | 70 | 70 | 70 | 70 | |
| | 024060 036060 048060 | 2 Pipe or 2-in Concentric | 1-1/2 | 15 | 10 | 5 | NA | NA | NA | |
| | | | 2 | 64 | 59 | 58 | 53 | 52 | 52 | |
| | 036080 048080 060080 | 2 Pipe or 2-in Concentric | 2 | 44 | 39 | 26 | 21 | 20 | 11 | |
| | | | 2-1/2 | 70 | 70 | 70 | 70 | 70 | 70 | |
| | 048100 060100 | 2 Pipe or 3-in Concentric | 2-1/2 | 31 | 22 | 13 | 12 | NA | NA | |
| | | | 3 | 70 | 70 | 67 | 62 | 57 | 52 | |
| | 060120 | 2 Pipe or 3-in. Concentric | 3† no disk | 53 | 46 | 40 | 33 | 26 | 20 | |
| | | | 4† no disk | 70 | 70 | 70 | 70 | 70 | 70 | |
| | 060140 | 2 Pipe or 3-in. Concentric | 3† no disk | 21 | 17 | 13 | 9 | 5 | NA | |
| | | | 4† no disk | 69 | 64 | 59 | 54 | 49 | 44 | |
| ALTITUDE (FT) | UNIT SIZE | TERMINATION TYPE | PIPE DIA (IN.)* | NUMBER OF 90° ELBOWS | | | | | | |
| 5001 to 6000‡ | 024040 036040 | 2 Pipe or 2-in Concentric | 1-1/2 | 57 | 52 | 47 | 42 | 40 | 35 | |
| | | | 2 | 70 | 70 | 70 | 70 | 70 | 70 | |
| | 024060 036060 048060 | 2 Pipe or 2-in Concentric | 1-1/2 | 14 | 9 | NA | NA | NA | NA | |
| | | | 2 | 60 | 55 | 54 | 49 | 48 | 47 | |
| | 036080 048080 060080 | 2 Pipe or 2-in Concentric | 2 | 41 | 36 | 23 | 18 | 17 | 8 | |
| | | | 2-1/2 | 70 | 70 | 70 | 70 | 70 | 70 | |
| | 048100 060100 | 2 Pipe or 3-in Concentric | 2-1/2 | 29 | 21 | 12 | 11 | NA | NA | |
| | | | 3 | 70 | 67 | 62 | 57 | 52 | 47 | |
| | 060120 | 2 Pipe or 3-in. Concentric | 3† no disk | 42 | 35 | 29 | 22 | 15 | 9 | |
| | | | 4† no disk | 70 | 70 | 70 | 70 | 70 | 70 | |
| | 060140 | 2 Pipe or 3-in. Concentric | 3† no disk | 12 | 8 | NA | NA | NA | NA | |
| | | | 4† no disk | 42 | 37 | 32 | 27 | 22 | 17 | |
| ALTITUDE (FT) | UNIT SIZE | TERMINATION TYPE | PIPE DIA (IN.)* | NUMBER OF 90° ELBOWS | | | | | | |
| 6001 to 7000‡ | 024040 036040 | 2 Pipe or 2-in Concentric | 1-1/2 | 53 | 48 | 43 | 38 | 37 | 32 | |
| | | | 2 | 70 | 70 | 68 | 67 | 66 | 64 | |
| | 024060 036060 048060 | 2 Pipe or 2-in Concentric | 1-1/2 | 13 | 8 | NA | NA | NA | NA | |
| | | | 2 | 57 | 52 | 50 | 45 | 44 | 43 | |
| | 036080 048080 060080 | 2 Pipe or 2-in Concentric | 2 | 38 | 33 | 21 | 16 | 15 | 6 | |
| | | | 2-1/2 | 70 | 70 | 68 | 67 | 66 | 64 | |
| | 048100 060100 | 2 Pipe or 3-in Concentric | 2-1/2 | 27 | 19 | 10 | 9 | NA | NA | |
| | | | 3 | 68 | 63 | 58 | 53 | 48 | 43 | |
| | 060120 | 2 Pipe or 3-in. Concentric | 3† no disk | 31 | 24 | 18 | 11 | NA | NA | |
| | | | 4† no disk | 70 | 70 | 70 | 70 | 67 | 62 | |
| | 060140 | 2 Pipe or 3-in. Concentric | 4† no disk | 17 | 12 | 7 | NA | NA | NA | |
| | ALTITUDE (FT) | UNIT SIZE | TERMINATION TYPE | PIPE DIA (IN.)* | NUMBER OF 90° ELBOWS | | | | | |
| 7001 to 8000‡ | 024040 036040 | 2 Pipe or 2-in Concentric | 1-1/2 | 49 | 44 | 39 | 34 | 33 | 28 | |
| | | | 2 | 66 | 65 | 63 | 62 | 60 | 59 | |
| | 024060 036060 048060 | 2 Pipe or 2-in Concentric | 1-1/2 | 12 | 7 | NA | NA | NA | NA | |
| | | | 2 | 53 | 48 | 46 | 41 | 40 | 38 | |
| | 036080 048080 060080 | 2 Pipe or 2-in Concentric | 2 | 36 | 31 | 19 | 14 | 12 | NA | |
| | | | 2-1/2 | 66 | 65 | 63 | 62 | 60 | 59 | |
| | 048100 060100 | 2 Pipe or 3-in Concentric | 2-1/2 | 25 | 17 | 8 | 7 | NA | NA | |
| | | | 3 | 63 | 58 | 53 | 48 | 43 | 38 | |
| | 060120 | 2 Pipe or 3-in. Concentric | 3† no disk | 20 | 13 | 7 | NA | NA | NA | |
| | | | 4† no disk | 61 | 56 | 51 | 46 | 41 | 36 | |
| | 060140 | | | | NA | | | | | |

See notes on page 28

TABLE 7—MAXIMUM ALLOWABLE PIPE LENGTH (FT) (CONTINUED)

| ALTITUDE (FT) | UNIT SIZE | TERMINATION TYPE | PIPE DIA (IN.)* | NUMBER OF 90° ELBOWS | | | | | |
|-----------------|----------------------------|----------------------------|-----------------|----------------------|----|----|----|----|----|
| | | | | 1 | 2 | 3 | 4 | 5 | 6 |
| 8001 to 9000‡ | 024040 036040 | 2 Pipe or 2-in Concentric | 1-1/2 | 46 | 41 | 36 | 31 | 29 | 24 |
| | | | 2 | 62 | 60 | 58 | 56 | 55 | 53 |
| | 024060 036060 048060 | 2 Pipe or 2-in Concentric | 1-1/2 | 11 | 6 | NA | NA | NA | NA |
| | | | 2 | 49 | 44 | 42 | 37 | 35 | 34 |
| | 036080 048080 060080 | 2 Pipe or 2-in Concentric | 2 | 33 | 28 | 17 | 12 | 10 | NA |
| | | | 2-1/2 | 62 | 60 | 58 | 56 | 55 | 53 |
| | 048100 060100 | 2 Pipe or 3-in Concentric | 2-1/2 | 23 | 15 | 7 | 5 | NA | NA |
| | | | 3 | 59 | 54 | 49 | 44 | 39 | 34 |
| | 060120 | 2 Pipe or 3-in. Concentric | 3† no disk | 10 | NA | NA | NA | NA | NA |
| | | | 4† no disk | 35 | 30 | 25 | 20 | 15 | 10 |
| 060140 | | | NA | | | | | | |
| ALTITUDE (FT) | UNIT SIZE | TERMINATION TYPE | PIPE DIA (IN.)* | NUMBER OF 90° ELBOWS | | | | | |
| 9001 to 10,000‡ | 024040 036040 | 2 Pipe or 2-in Concentric | 1-1/2 | 42 | 37 | 32 | 27 | 25 | 20 |
| | | | 2 | 57 | 55 | 53 | 51 | 49 | 47 |
| | 024060 036060 048060 | 2 Pipe or 2-in Concentric | 2 | 45 | 40 | 38 | 33 | 31 | 29 |
| | | | 2 | 30 | 25 | 14 | 9 | 7 | NA |
| | 036080 048080 060080 | 2 Pipe or 2-in Concentric | 2-1/2 | 57 | 55 | 53 | 51 | 49 | 47 |
| | | | 2-1/2 | 21 | 13 | 5 | NA | NA | NA |
| | 048100 060100 | 2 Pipe or 3-in Concentric | 3 | 54 | 49 | 44 | 39 | 34 | 29 |
| | | | 4† no disk | 10 | 5 | NA | NA | NA | NA |
| | 060140 | | | NA | | | | | |

Disk usage—Unless otherwise specified, use perforated disk assembly (factory-supplied in loose parts bag). If one disk is stated, separate 2 halves of perforated disk assembly and use shouldered disk half. When using shouldered disk half, install screen side toward inlet box.

†Wide radius elbow.

‡Vent sizing for Canadian installations over 4500 ft (1370 m) above sea level are subject to acceptance by the local authorities having jurisdiction.

NA—Not Allowed; pressure switch will not make.

NOTES:

1. Do not use pipe size greater than those specified in table or incomplete combustion, flame disturbance, or flame sense lockout may occur.
2. Size both the combustion-air and vent pipe independently, then use the larger diameter for both pipes.
3. Assume two 45° elbows equal one 90° elbow. Long radius elbows are desirable and may be required in some cases.
4. Elbows and pipe sections within the furnace casing and at the vent termination should not be included in vent length or elbow count.
5. The minimum pipe length is 5 ft for all applications.
6. Use 3-in. diameter vent termination kit for installations requiring 4-in diameter pipe.

VENT EXTENSION PIPE

Furnaces with 100,000 Btuh and larger inputs are supplied with a PVC vent extension pipe (2-in. diameter by 12-in. long). This pipe has a built-in channel to assist vent condensate disposal. When this vent extension pipe is supplied, it must be used to connect the field vent pipe to furnace inducer housing on ALL upflow and down-flow applications.

NOTE: See label on vent extension pipe for proper installation. This pipe may be shortened if an elbow is used to connect vent extension tube to field-installed vent pipe.

3. Working from furnace to outside, cut pipe to required length(s).
4. Deburr inside and outside of pipe.
5. Chamfer outside edge of pipe for better distribution of primer and cement.
6. Clean and dry all surfaces to be joined.
7. Check dry fit of pipe and mark insertion depth on pipe.

NOTE: It is recommended that all pipes be cut, prepared, and preassembled before permanently cementing any joint.

8. After pipes have been cut and preassembled, apply generous layer of cement primer to pipe fitting socket and end of pipe to insertion mark. Quickly apply approved cement to end of pipe and fitting socket (over primer). Apply cement in a light, uniform coat on inside of socket to prevent buildup of excess cement. Apply second coat.

9. While cement is still wet, twist pipe into socket with 1 /4 turn. Be sure pipe is fully inserted into fitting socket.

10. Wipe excess cement from joint. A continuous bead of cement will be visible around perimeter of a properly made joint.

11. Handle pipe joints carefully until cement sets.

12. Support combustion-air and vent piping a minimum of every 5 ft (3 ft for SDR-21 or -26 PVC) using perforated metal hanging strap.

13. Slope combustion-air and vent pipes toward furnace a minimum of 1/4 in. per linear ft with no sags between hangers.

14. Use appropriate methods to seal openings where vent and combustion-air pipes pass through roof or side wall.

C. Concentric Vent and Combustion-Air Termination Kit Installation

NOTE: If these instructions differ from those packaged with termination kit, follow kit instructions.

Combustion-air and vent pipes must terminate outside structure. A factory accessory termination kit must be installed in 1 of the installations shown in Fig. 36, 37, 38, 39, and 40. Four termination kits are available.

1. The 2-in. termination bracket kit is for 1-in., 1-1/2 in., and 2-in. diameter 2-pipe termination systems.

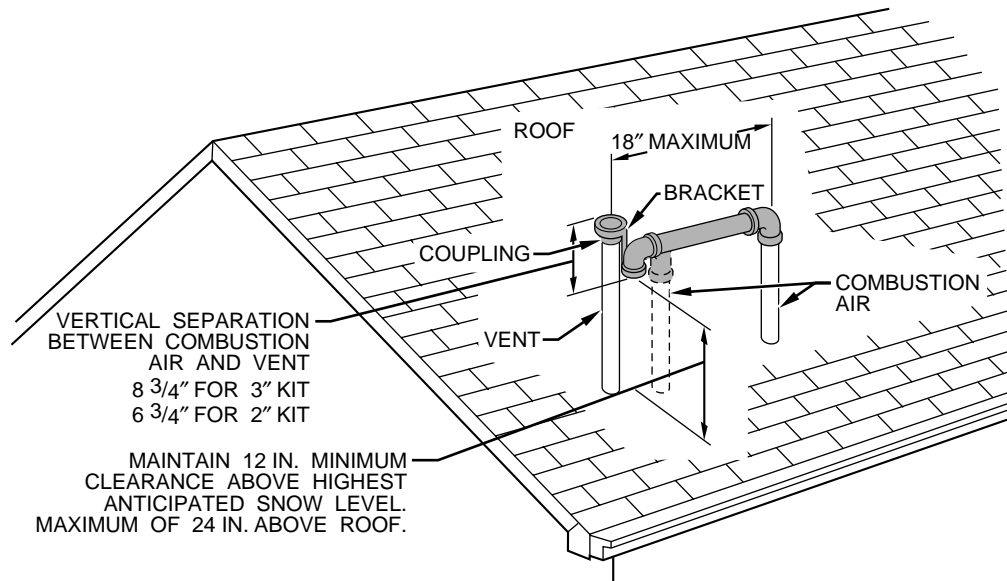

A87224

Fig. 36—Roof Termination (Preferred)

2. The 3-in. termination bracket kit is for 2-1/2 in., 3-in., and 4-in. diameter 2-pipe termination systems.
3. The 2-in. concentric vent/air termination kit is for 1-in., 1-1/2 in., 2-in., and 2-1/2 in. diameter pipe systems when single penetration of wall or roof is desired.
4. The 3-in. concentric vent/air termination kit is for 2-1/2 in., 3-in., and 4-in. diameter pipe systems when single penetration of wall or roof is desired.

NOTE: Shaded parts in Fig. 36, 37, 38, 39, and 40 are considered to be termination. These components should NOT be counted when determining pipe diameter. Roof termination is preferred since it is less susceptible to damage, has reduced chances to take in contaminants, and has less visible vent vapors. (See Fig. 36 or 37.) Sidewall termination may require sealing or shielding of building surfaces with a corrosive resistance material due to corrosive combustion products of vent system.

EXTENDED EXPOSED SIDEWALL PIPES

Sidewall combustion-air and vent pipe terminations may be extended beyond area shown in Fig. 39 or 40 in outside ambient by insulating pipes as indicated in Table 8.

1. Determine combustion-air and vent pipe diameters, as stated above, using total pipe length and number of elbows.
2. Using winter design temperature (used in load calculations), find appropriate temperature for your application and furnace model.
3. Determine required insulation thickness for exposed pipe lengths.

NOTE: Pipe length (ft) specified for maximum pipe lengths located in unconditioned spaces. Pipes located in unconditioned space cannot exceed total allowable pipe length as specified in Table 7.

TWO-PIPE TERMINATION KIT

1. Determine location for termination. Consideration of the following should be made when determining an appropriate location for termination kit.
 - a. Comply with all clearance requirements as stated in Table 5.
 - b. Termination kit should be positioned where vent vapors will not damage plants/shrubs or air conditioning equipment.

- c. Termination kit should be positioned so that it will not be affected by wind eddy (such as inside building corners) or allow recirculation of flue gases, airborne leaves, or light snow.
- d. Termination kit should be positioned where it will not be damaged by or subjected to foreign objects, such as stones, balls, etc.
- e. Termination kit should be positioned where vent vapors are not objectionable.

2. Cut 2 holes, 1 for each pipe, of appropriate size for pipe size being used.
3. Loosely install elbow in bracket and place assembly on combustion-air pipe.

Roof terminations—Loosely install pipe coupling on properly cut vent pipe. Coupling must be positioned so bracket will mount as shown in Fig. 36.

For applications using combustion-air pipe option, indicated by dashed lines in Fig. 36, install 90° street elbow into 90° elbow, making U-fitting. A 180° U-fitting may be used.

Sidewall terminations—Install bracket as shown in Fig. 39 or 40.

For applications using vent pipe option indicated by dashed lines in Fig. 39, rotate vent elbow 90° from position shown in Fig. 39.

4. Disassemble loose pipe fittings. Clean and cement using same procedures as used for system piping.
5. Check required dimensions as shown in Fig. 36, 39, or 40.

CONCENTRIC VENT/AIR TERMINATION KIT

1. Determine location for termination. Consideration of the following should be made when determining an appropriate location for termination kit.
 - a. Comply with all clearance requirements as stated in Table 5.
 - b. Termination kit should be positioned where vent vapors will not damage plants/shrubs or air conditioning equipment.
 - c. Termination kit should be positioned so it will not be affected by wind eddy (such as inside building corners) or that may allow recirculation of flue gases, airborne leaves, or light snow.

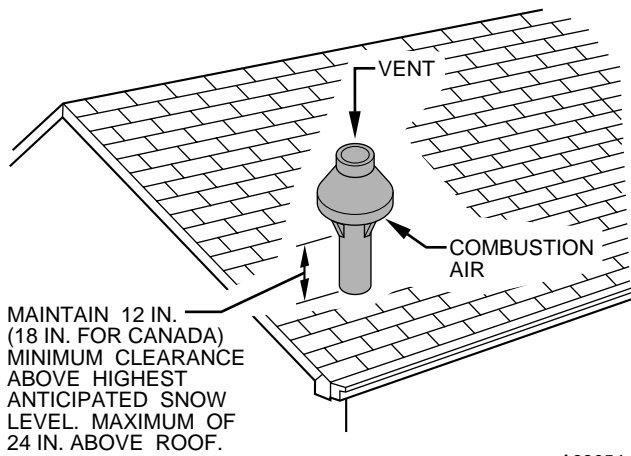

A93054

Fig. 37—Concentric Vent and Combustion-Air Roof Termination (Preferred)

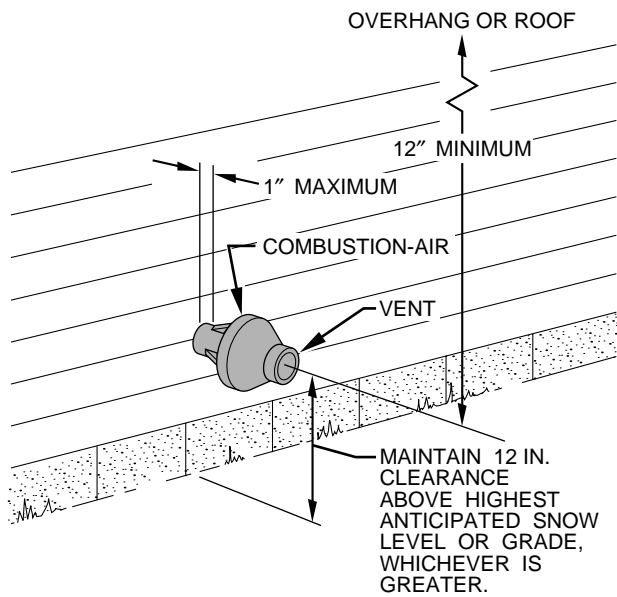

A93055

Fig. 38—Concentric Vent and Combustion-Air Side Termination

- d. Termination kit should be positioned where it will not be damaged by or subjected to foreign objects, such as stones, balls, etc.
 - e. Termination kit should be positioned where vent vapors are not objectionable.
2. Cut one 4-in. diameter hole for 2-in. kit, or one 5-in. diameter hole for 3-in. kit.
 3. Loosely assemble concentric vent/air termination components together using instructions in kit.
 4. Slide assembled kit with rain shield REMOVED through hole.

NOTE: Do not allow insulation or other materials to accumulate inside of pipe assembly when installing it through hole.

Roof terminations—Locate assembly through roof to appropriate height as shown in Fig. 37.

Sidewall terminations—Locate assembly through sidewall with rain shield positioned no more than 1-in. from wall as shown in Fig. 38.

5. Disassemble loose pipe fittings. Clean and cement using same procedures as used for system piping.

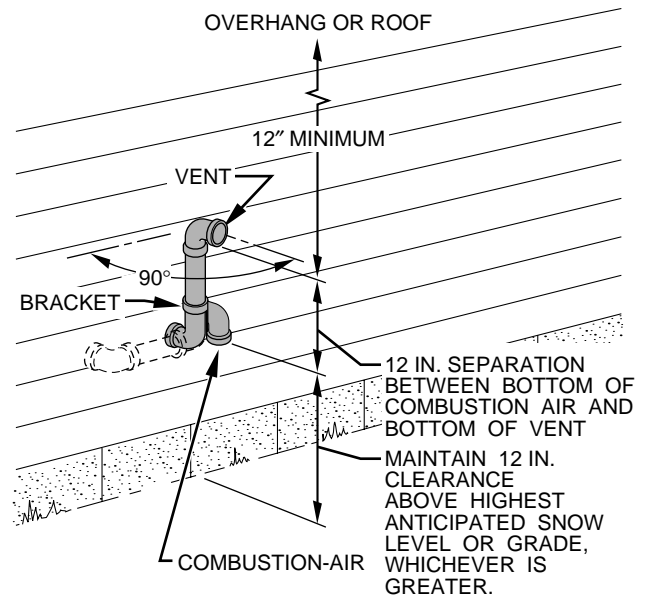

A87225

Fig. 39—Sidewall Termination of 12 in. or More

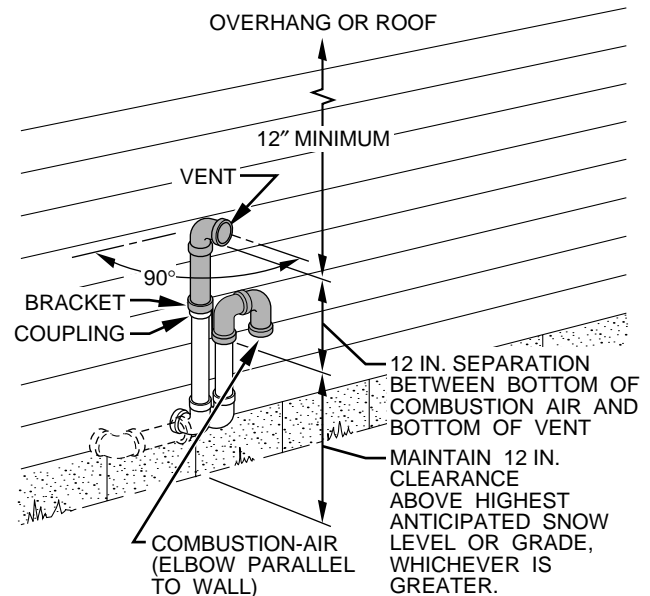

A87226

Fig. 40—Sidewall Termination of Less than 12 in.

6. Check required dimensions as shown in Fig. 37 or 38.

D. Multiventing and Vent Terminations

When 2 or more 350MAV Furnaces are vented near each other, each furnace must be individually vented. NEVER common vent or breach vent 350MAV furnaces. When 2 or more 350MAV furnaces are vented near each other, 2 vent terminations may be installed as shown in Fig. 41, 42, 43, 44, and 45, but next vent termination must be at least 36 in. away from first 2 terminations. It is important that vent terminations be made as shown to avoid recirculation of flue gases. Dimension "A" in Fig. 41, 42, 43, 44, and 45 represents distance between pipes or rain shields, as touching or 2-in. maximum separation.

TABLE 8—MAXIMUM ALLOWABLE EXPOSED VENT PIPE LENGTH (FT) WITH AND WITHOUT INSULATION IN WINTER DESIGN TEMPERATURE AMBIENT*

| UNIT SIZE | WINTER DESIGN TEMPERATURE (°F) | MAX PIPE DIAMETER (IN.) | WITHOUT INSULATION | WITH 3/8-IN. OR THICKER INSULATION† |
|-----------|--------------------------------|-------------------------|--------------------|-------------------------------------|
| 040 | 20 | 1.5 | 51 | 70 |
| | 0 | 1.5 | 28 | 70 |
| | -20 | 1.5 | 16 | 70 |
| | 20 | 2 | 45 | 70 |
| | 0 | 2 | 22 | 70 |
| | -20 | 2 | 10 | 58 |
| 060 | 20 | 2 | 65 | 70 |
| | 0 | 2 | 35 | 70 |
| | -20 | 2 | 20 | 70 |
| 080 | 20 | 2 | 55 | 55 |
| | 0 | 2 | 48 | 55 |
| | -20 | 2 | 30 | 55 |
| | 20 | 2.5 | 70 | 70 |
| | 0 | 2.5 | 47 | 70 |
| | -20 | 2.5 | 28 | 70 |
| 100 | 20 | 2.5 | 40 | 40 |
| | 0 | 2.5 | 40 | 40 |
| | -20 | 2.5 | 38 | 40 |
| | 20 | 3 | 70 | 70 |
| | 0 | 3 | 50 | 70 |
| | -20 | 3 | 28 | 70 |
| 120 | 20 | 3 | 70 | 70 |
| | 0 | 3 | 61 | 70 |
| | -20 | 3 | 37 | 70 |
| | 20 | 4 | 70 | 70 |
| | 0 | 4 | 48 | 70 |
| | -20 | 4 | 23 | 70 |
| 140 | 20 | 3 | 60 | 60 |
| | 0 | 3 | 60 | 60 |
| | -20 | 3 | 44 | 60 |
| | 20 | 4 | 70 | 70 |
| | 0 | 4 | 57 | 70 |
| | -20 | 4 | 30 | 70 |

* Pipe length (ft) specified for maximum pipe lengths located in unconditioned spaces. Pipes located in unconditioned space cannot exceed total allowable pipe length as specified in Table 7.

† Insulation thickness based on R value of 3.5 (ft • °F • hr)/(Btu•in.)

| | |
|---|--|
| ⚠ | <p>CAUTION: Unit must not be installed, operated, and then turned off and left in an unoccupied structure during cold weather when temperature drops to 32°F and below unless drain trap and drain line have adequate freeze protection. See Service and Maintenance Instructions for winterizing procedure. (See Fig. 15.)</p> |
|---|--|

X. CONDENSATE DRAIN

A. General

Condensate trap is shipped installed in the blower shelf and factory connected for UPFLOW application. Condensate trap must be RELOCATED for use in DOWNFLOW and HORIZONTAL applications.

Condensate trap MUST be used for all applications.

An external trap is not required when connecting the field drain to this condensate trap.

The field drain connection (condensate trap or drain tube coupling) is sized for 1/2-in. CPVC, 1/2-in. PVC, or 5/8-in. ID tube connection.

→ Drain pipe and fittings must conform to ANSI standards and ASTM as shown in Table 5. In Canada, use CSA or ULC certified schedule 40 CPVC or PVC drain pipe, fittings, and cement.

When a condensate pump is required, select a pump which is approved for condensing furnace applications. To avoid condensate spillage, select a pump with an overflow switch.

Furnace condensate is mildly acidic, typically in the pH range of 3.2 to 4.5. Due to corrosive nature of this condensate, a condensate 38 pH neutralizing filter may be desired. Check with local authorities to determine if a pH neutralizer is required.

B. Application

The furnace, A/C, and humidifier drains may be combined and drained together. The A/C drain must have an external, field-supplied trap prior to the furnace drain connection. All drain connections (furnace, A/C, or humidifier) must be terminated into an open or vented drain as close to the respective equipment as possible to prevent siphoning of the equipment's drain.

See Fig. 46 for 2 of possible field drain attachment using 1/2-in. CPVC or PVC tee for vent and A/C or humidifier drain connection.

Outdoor draining of the furnace is permissible if allowed by local codes. Caution should be taken when freezing ambient may freeze drain pipe and prohibit draining.

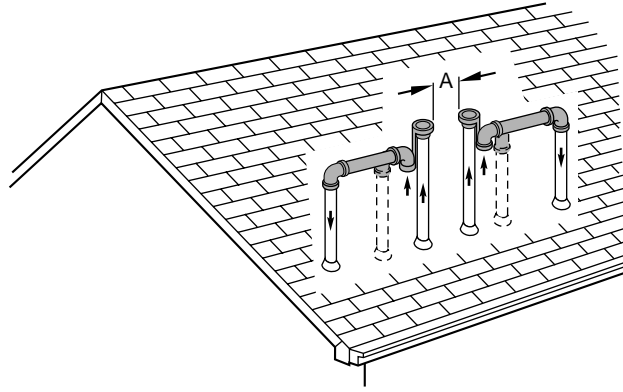

A96128

Fig. 41—Rooftop Termination (Dimension “A” is Touching or 2-in. Maximum Separation)

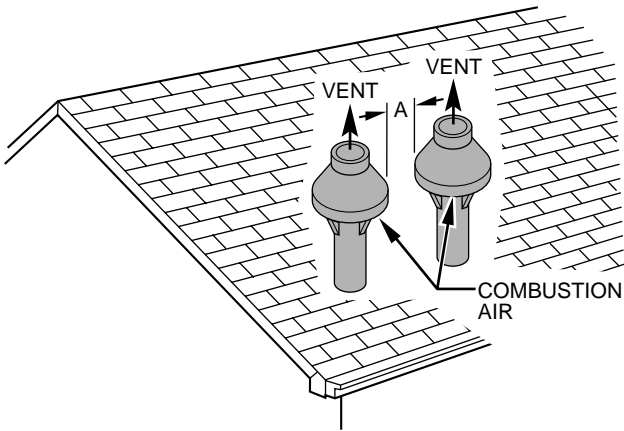

A93056

Fig. 42—Concentric Vent and Combustion-Air Roof Termination (Dimension “A” is Touching or 2-in. Maximum Separation)

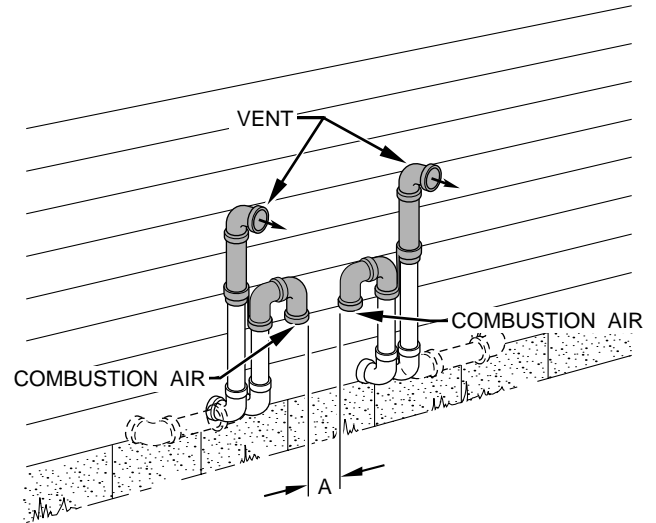

A96129

Fig. 44—Sidewall Termination of 12 in. or Less (Dimension “A” is Touching or 2-in. Maximum Separation)

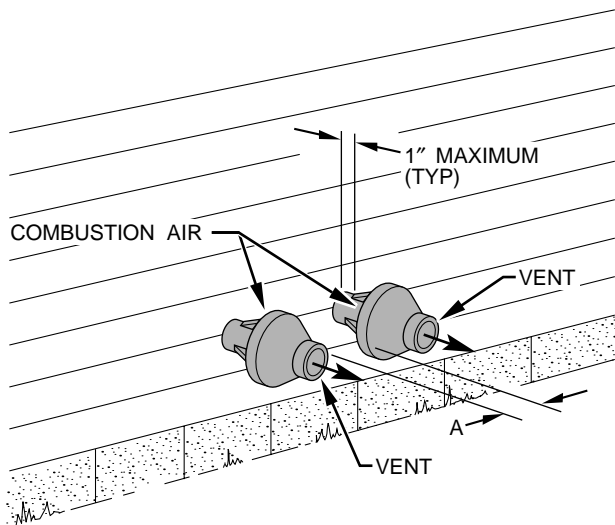

A93057

Fig. 43—Concentric Vent and Combustion-Air Side Termination (Dimension “A” is Touching or 2-in. Maximum Separation)

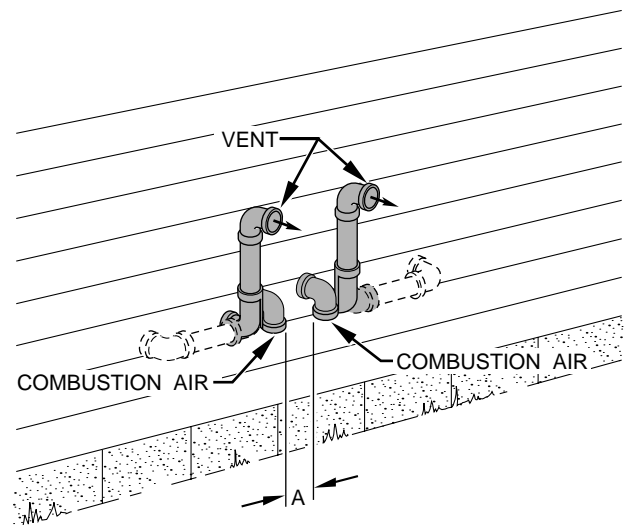

A96130

Fig. 45—Sidewall Termination of More than 12 in. (Dimension “A” is Touching or 2-in. Maximum Separation)

WARNING: Caution should be taken to prevent draining where slippery conditions may cause personal injuries. Excessive condensate draining may cause saturated soil conditions which may result in damage to plants.

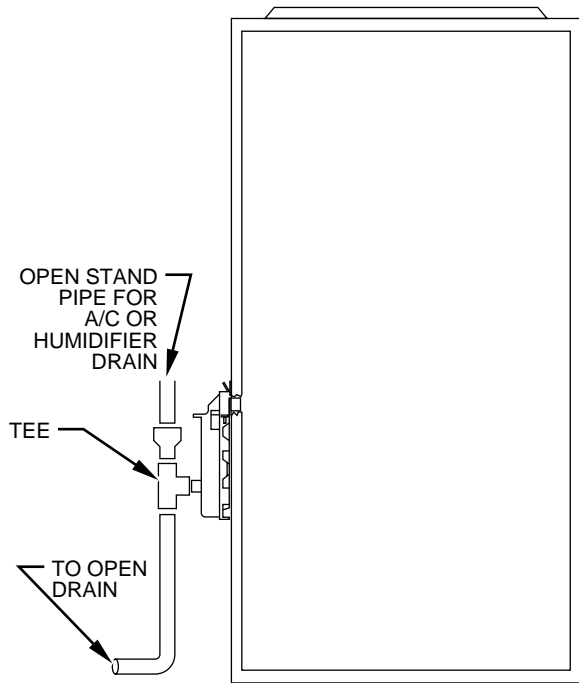

A94054

Fig. 46—Example of Field Drain Attachment

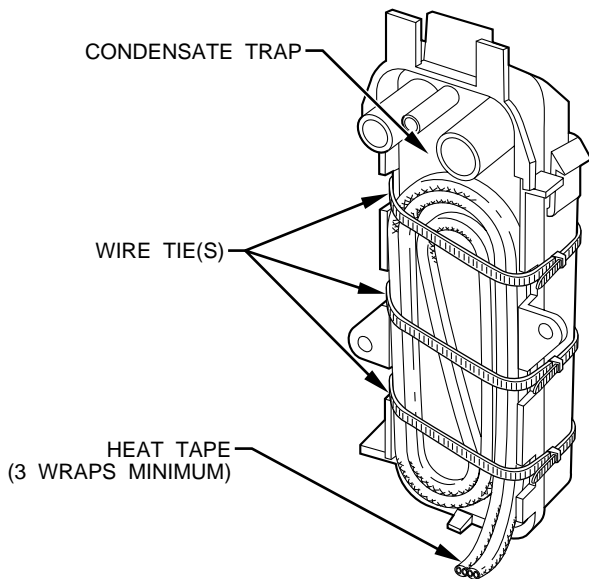

A93036

Fig. 47—Condensate Trap Heat Tape

C. Condensation Drain Protection

Freezing condensate left in condensate trap and drain line may cause cracks, and possible water damage may occur. If freeze protection is required, use condensate freeze protection accessory or equivalent 3 to 6 watt per ft at 120-v and 40°F self-regulating, shielded, and waterproof heat tape. See Installation Instructions supplied with accessory or heat tape manufacturer’s recommendations.

1. Fold heat tape in half and wrap on itself 3 times.

2. Locate heat tape between sides of condensate trap back. (See Fig. 47.)
3. Use wire ties to secure heat tape in place. Wire ties can be positioned in notches of condensate trap sides. (See Fig. 47.)
4. Wrap field drain pipe with remaining heat tape, approximately 1 wrap per ft.
5. When using field-supplied heat tape, follow heat tape manufacturer’s instructions for all other installation guidelines.

XI. SEQUENCE OF OPERATION

CAUTION: Furnace control must be grounded for proper operation, or control will lock out. Control is grounded through green wire routed to gas valve and burner box screw.

Using schematic diagram, follow sequence of operation through different modes. (See Fig. 30.) Read and follow wiring diagram carefully.

NOTE: If 115-v power supply to furnace or blower access panel switch is interrupted during a call for heat, blower operates for 90 sec when power is restored before heating cycle is resumed.

A. Heating Mode

When wall thermostat calls for heat, R-W circuit closes. Furnace control performs a self-check, verifies pressure switch contacts are open, and starts inducer motor.

1. **Prepurge period**—As inducer motor comes up to speed, pressure switch contacts close to begin a 15-sec prepurge period.
2. **Ignitor warm up**—At end of prepurge period, ignitor is energized for a 17-sec ignitor warm-up period.
3. **Ignition sequence**—When ignitor warm-up period is completed, gas valve opens, permitting gas flow to burners where it is ignited. After 5 sec, ignitor is de-energized and a 2-sec flame-sensing period begins. HUM terminal on control center is energized with gas valve. See Accessories - Humidifier section.

4. **Flame sensing**—When burner flame is sensed, control begins blower on delay period and continues holding gas valve open. If burner flame is not sensed, control center de-energizes gas valve and ignition sequence is repeated.

NOTE: Ignition sequence repeats 3 additional times before a lockout occurs. Lockout automatically resets after 3 hr or can be manually reset by turning off 115-v (not at thermostat) for 3 sec minimum, then turning it on again.

5. **Blower on delay**—Sixty sec after burner flame is proven (40 sec if jumper has been cut for 140 size unit in downflow orientation), blower motor is energized on heating speed. Simultaneously, electronic air cleaner terminal EAC-1 is energized.
6. **Blower off delay**—When thermostat is satisfied, circuit between R-W is opened, de-energizing gas valve (stopping gas flow to burners) and humidifier. Blower motor and electronic air cleaner remains energized 90, 135, 180, or 225 sec (depending on blower off time selection). Furnace is factory shipped set for a 135-sec blower off delay.
7. **Post purge**—inducer motor remains energized 15 sec after burners are extinguished (5 sec if jumper has been cut for 140 size unit in downflow orientation).

B. Cooling Mode

When thermostat calls for cooling, R-G and R-Y circuits close. R-Y circuit starts outdoor condensing unit, and combined R-Y and R-G circuit starts furnace blower motor on cooling speed. Electronic air cleaner EAC-1 terminal is energized with 115-v whenever blower is operating.

When thermostat is satisfied, R-G and R-Y circuits are opened, furnace blower continues operating on cooling speed for an additional 90 sec.

C. Continuous Blower Mode

When R-G circuit is made, blower motor operates on heating speed.

NOTE: Electronic air cleaner EAC-1 terminal is energized with 115-v whenever blower is operating.

If a call for heat (R-W) occurs while thermostat is in continuous blower mode, blower stops to allow furnace heat exchangers to heat up more quickly, then restarts at end of blower on delay period of 60 sec (40 sec if jumper has been cut for 140 size unit in downflow orientation).

Blower reverts to continuous operation after heating cycle is completed.

If a call for cooling (R-Y) occurs while thermostat is in continuous blower mode, blower changes from continuous blower speed (heating speed) to cooling speed.

When thermostat cooling call is satisfied, R-Y opens and blower operates an additional 90 sec at cooling speed before reverting back to continuous operation (heating speed).

D. Heat Pump Mode

When installed with a heat pump, furnace control automatically changes blower on delay timing sequence to avoid no blower operation time during demand defrost cycles. When R-W and R-Y or R-W, R-Y, and R-G thermostat inputs are received at the same time at furnace control center, control starts blower in heating speed. Then a gas heat mode begins. Blower remains operating at heating speed for 15 sec or until end of prepurge period, then blower shuts off until end of ignitor warm up and trial for ignition periods (a total of 24 sec). Blower restarts at heating speed.

When R-W thermostat call disappears, control completes inducer post-purge period of 15 sec (5 sec if jumper has been cut for 140 size unit in downflow orientation) and changes to cooling speed after a 2-sec delay.

If R-W, R-Y, and R-G thermostat signals should disappear simultaneously, blower remains on for selected heating blower off delay period (90, 135, 180, or 225 sec), and the inducer goes through 15 sec post-purge period (5 sec if jumper has been cut for 140 size unit in downflow orientation). If R-W and R-Y thermostat signals should disappear, leaving R-G thermostat signal, blower remains on in heating speed and inducer remains on for 15 sec (5 sec if jumper has been cut for 140 size unit in downflow orientation) to complete post-purge period.

Control initiates a 90-sec blower only on period before starting another heat pump cycle if there is a power interruption. Anytime control senses false flame, control locks out of heating mode. This reaction occurs because control ignores W input due to false flame signal and, as a result, sees only Y input and goes into cooling mode blower off delay. All other control functions remain in standard format.

NOTE: EAC-1 terminal is energized whenever blower operates. HUM terminal is only energized when gas valve is energized.

E. Component Test

COMPONENT TEST SEQUENCE

NOTE: All components are functionally operated except the gas valve.

When component test is initiated, the following sequence of events occurs:

1. LED flashes a status code 4 times.
2. Inducer motor starts and continues to run for remainder of component test.
3. Hot surface ignitor is energized for 15 sec, then de-energized.

4. Main blower operates at cooling speed for 10 sec, then turns off.
5. Main blower operates at heating speed for 10 sec, then turns off.
6. Inducer motor stops.

INITIATING COMPONENT TEST BY REMOVING MAIN LIMIT SWITCH WIRE

NOTE: NO thermostat signal may be present at control center and all blower time delay off periods must be completed.

1. Leave 115-v power to furnace turned on.
2. Remove main furnace door.
3. Look into blower access panel sight glass for current LED status.

NOTE: Leave blower access panel installed to maintain power to control center to view current LED status.

4. BRIEFLY remove either wire from the main limit switch until the LED goes out, then reconnect it.

| | |
|---|--|
|  | CAUTION: Make sure limit switch wire does not contact any metallic component such as the gas valve. If wire is shorted, 3-amp fuse on control center will blow. |
|---|--|

NOTE: If wire to main limit is disconnected longer than 4 sec, the control senses limit circuit is open. Main blower will start and status retrieval request will be ignored.

5. When above items have been completed, the component test sequence will occur as described in the Component Test Sequence section above.

NOTE: Be sure to record the status code which is flashed 4 times at start of component test for further troubleshooting.

6. After component test is completed and LED is ON continuously indicating the furnace is ready to operate when a signal from the thermostat is received, replace main furnace door.

INITIATING COMPONENT TEST BY JUMPERING CONTROL TEST TERMINAL

1. Remove main furnace door.
2. Remove blower access panel.
3. Manually close blower access panel door switch. Use a piece of tape to hold switch closed.

| | |
|---|--|
|  | WARNING: Blower access panel door switch opens 115-v power to control center. No component operation can occur. Caution must be taken when manually closing this switch for service purposes. Failure to follow this warning could result in electrical shock, personal injury, or death. |
|---|--|

4. BRIEFLY short (jumper) TEST, 1/4-in. quick-connect terminal on control center (adjacent to the LED diagnostic light) and the COM terminal on thermostat connection block. (See Fig. 31.)

NOTE: If TEST to COM terminals are jumpered longer than 2 sec, LED will flash rapidly, and retrieval request will be ignored.

5. When above items have been completed, the component test sequence will occur as described in the Component Test Sequence section above.

NOTE: Be sure to record the status code which is flashed 4 times at start of component test for further troubleshooting.

- After component test is completed and furnace is operating properly, release blower access panel door switch, replace blower access panel, and replace main furnace door.

START-UP PROCEDURES

I. GENERAL

- Furnace must have a 115-v power supply properly connected and grounded. Proper polarity must be maintained for correct operation.

NOTE: Proper polarity must be maintained for 115-v wiring. If polarity is incorrect, control center LED status indicator light will flash rapidly and furnace will not operate.

- Thermostat wire connections at terminals R, W, G, and Y must be made at 24-v terminal block on control center.
- Natural gas service pressure must not exceed 0.5 psig (14-in. wc), but must be no less than 0.16 psig (4.5-in. wc).
- Blower access panel must be in place to complete 24-v electrical circuit to furnace.

| | |
|---|--|
| ⚠ | <p>CAUTION: These furnaces are equipped with a manual reset limit switch in burner box. This switch will open if an overheat condition (rollout) occurs in burner enclosure. Correct inadequate combustion-air supply or improper venting condition and reset switch. DO NOT jumper this switch.</p> |
|---|--|

Before operating furnace, check each manual reset switch for continuity. If necessary, press button to reset switch.

II. PRIME CONDENSATE TRAP WITH WATER

| | |
|---|---|
| ⚠ | <p>CAUTION: Condensate trap must be PRIMED or proper draining may not occur. The condensate trap has 2 internal chambers which can ONLY be primed by pouring water into the inducer drain side of condensate trap.</p> |
|---|---|

- Remove upper inducer housing drain connection cap. (See Fig. 48.)
- Connect field-supplied 1/2-in. ID tube to upper inducer housing drain connection.
- Insert field-supplied funnel into tube.
- Pour 1 quart of water into funnel/tube. Water should run through inducer housing, overflow condensate trap, and flow into open field drain. (See Fig. 49.)
- Remove funnel and tube from inducer housing and replace drain connection cap and clamp.

III. PURGE GAS LINES

If not previously done, purge lines after all connections have been made and check for leaks.

| | |
|---|--|
| ⚠ | <p>WARNING: Never purge a gas line into a combustion chamber. Never use matches, candles, flame, or other sources of ignition for purpose of checking leakage. Use a soap-and-water solution to check for leakage. Failure to follow this warning could result in fire, explosion, personal injury, or death.</p> |
|---|--|

IV. ADJUSTMENTS

A. Set Gas Input Rate

Furnace gas input rate on rating plate is for installations at altitudes up to 2000 ft.

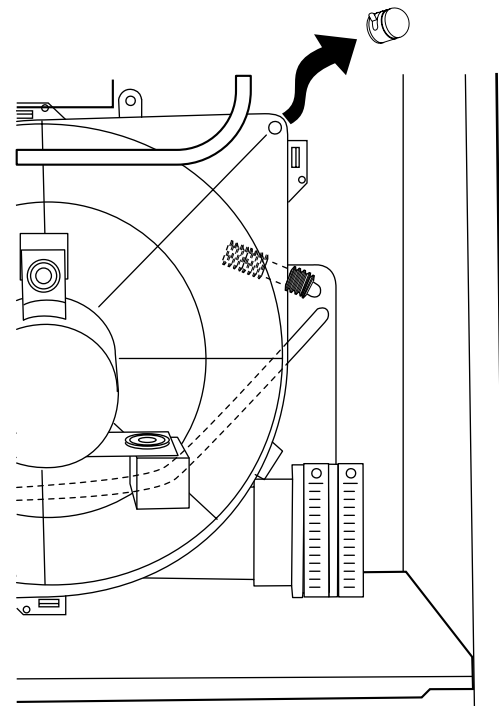

A99118

Fig. 48—Inducer Housing Drain Tube

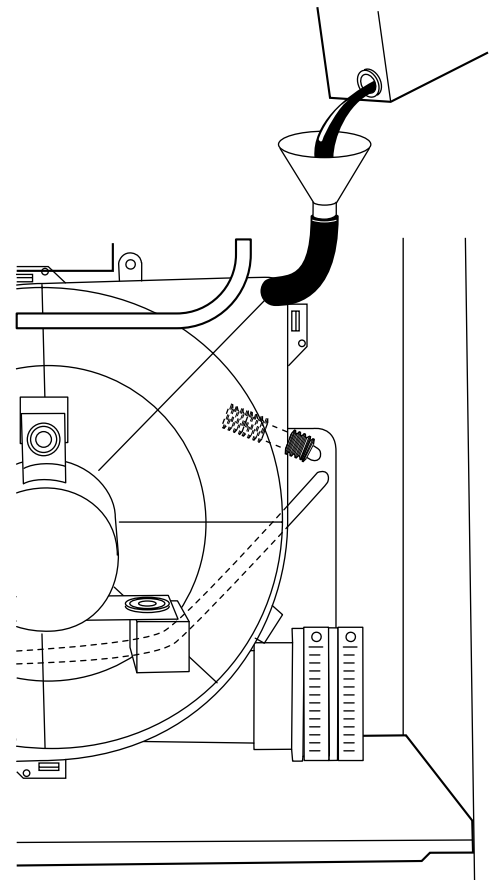

A99119

Fig. 49—Filling Condensate Trap

In the U.S.A., the input ratings for altitudes above 2000 ft must be reduced by 2 percent for each 1000 ft above sea level. In Canada, the input ratings must be derated by 5 percent for altitudes of 2000 ft to 4500 ft above sea level. Furnace input rate must be within ± 2 percent of input on furnace rating plate adjusted for altitude.

1. Determine natural gas orifice size and manifold pressure for correct input.
 - a. Obtain average yearly heat value (at installed altitude) from local gas supplier.
 - b. Obtain average yearly specific gravity from local gas supplier.
 - c. Verify furnace model and size. Table 9 can only be used for model 350MAV furnaces with heating sizes of 040 through 120. Table 10 can only be used for model 350MAV furnaces with a 140 heating size.
 - d. Find installation altitude in Table 9 or 10.

NOTE: For Canada altitudes of 2000 to 4500 ft, use U.S.A. altitudes of 2001 to 3000 ft in Table 9 or 10.

- e. Find closest natural gas heat value and specific gravity on Table 9 or 10.
- f. Follow heat value and specific gravity lines to point of intersection to find orifice size and manifold pressure settings for proper operation.

EXAMPLE: (0-2000 ft altitude using Table 9)
 Heating value = 1050 Btu/cu ft
 Specific gravity = 0.62
 Therefore: Orifice No. 45
 Manifold pressure 3.6-in. wc
 * Furnace is shipped with No. 45 orifices. In this example all main burner orifices are the correct size and do not need to be changed to obtain the proper input rate.

Check and verify burner orifice size in furnace. NEVER ASSUME ORIFICE SIZE; ALWAYS CHECK AND VERIFY.

2. Adjust manifold pressure to obtain input rate.

NOTE: Manifold pressure must always be measured with burner enclosure front REMOVED. Gas meter must always be clocked with burner enclosure front INSTALLED.

- a. Remove burner enclosure front.
- b. Remove cap that conceals adjustment screw for gas valve regulator. (See Fig. 50.)

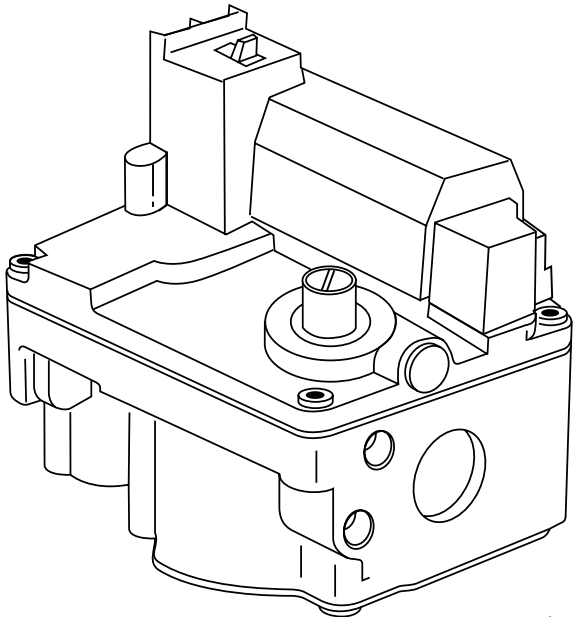

A00238

Fig. 50—Redundant Automatic Gas Valve

- c. Turn adjusting screw, counterclockwise (out) to decrease manifold pressure or clockwise (in) to increase manifold pressure.

NOTE: This furnace has been approved for a manifold pressure of 3.2 in. wc to 3.8 in. wc when installed at altitudes up to 2000 ft. For altitudes above 2000 ft, the manifold pressure can be adjusted from 2.0 in. wc to 3.8 in. wc.

CAUTION: DO NOT bottom out gas valve regulator adjusting screw. This can result in unregulated manifold pressure and result in excess overfire and heat exchanger failures.

NOTE: If orifice hole appears damaged or it is suspected to have been redrilled, check orifice hole with a numbered drill bit of correct size. Never redrill an orifice. A burr-free and squarely aligned orifice hole is essential for proper flame characteristics.

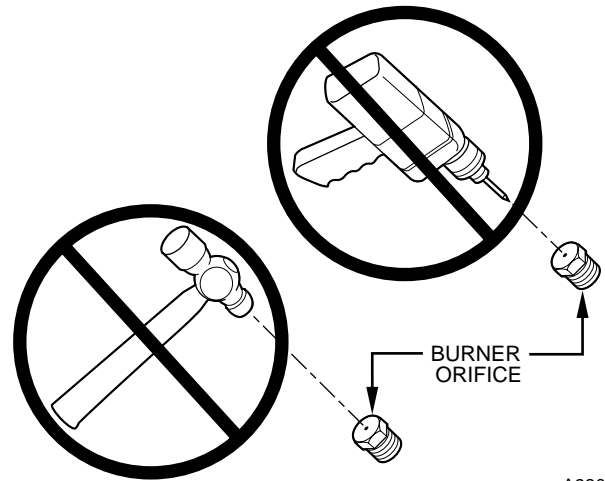

A93059

Fig. 51—Orifice Holes

CAUTION: DO NOT redrill orifices. Improper drilling (burrs, out-of-round holes, etc.) can cause excessive burner noise and misdirection of burner flames. This can result in flame impingement of burners and heat exchangers causing failures. (See Fig. 51.)

- d. Replace gas valve regulator adjustment screw cap.
- e. Replace burner enclosure front and verify adjusted gas input rate using method outlined in item 3.
- f. Look through sight glass in burner enclosure and check burner flame. Burner flame should be clear blue, almost transparent. (See Fig. 52.)

3. Verify natural gas input rate by clocking gas meter.

NOTE: Be sure all pressure tubing, combustion-air and vent pipes, and burner enclosure front are in place when checking input by clocking gas meter.

- a. Calculate high-altitude adjustment (if required).

UNITED STATES

At altitudes above 2000 ft, this furnace has been approved for a 2 percent derate for each 1000 ft above sea level. See Table 11 for derate multiplier factor.

CANADA

At installation altitudes from 2000 to 4500 ft, this furnace must be derated 5 percent by an authorized Gas Conversion Station or Dealer. To determine correct input rate for altitude, see example above and use 0.95 as derate multiplier factor.

- b. Turn off all other gas appliances and pilots.
- c. Start furnace and let operate for 3 minutes.

**TABLE 9—MODEL 350MAV ORIFICE SIZE AND MANIFOLD PRESSURE FOR CORRECT INPUT
FOR USE WITH 040 THROUGH 120 SIZE FURNACES ONLY
(TABULATED DATA BASED ON 20,000 BTUH PER BURNER, DERATED 2 PERCENT FOR EACH 1000 FT ABOVE SEA LEVEL)**

| ALTIMUDE RANGE (FT) | AVG GAS HEAT VALUE (BTU/CU FT) | SPECIFIC GRAVITY OF NATURAL GAS | | | | | | | | | |
|--|--------------------------------|---------------------------------|-------------------|-------------|-------------------|-------------|-------------------|-------------|-------------------|-------------|-------------------|
| | | 0.58 | | 0.60 | | 0.62 | | 0.64 | | 0.66 | |
| | | Orifice no. | Manifold Pressure | Orifice no. | Manifold Pressure | Orifice no. | Manifold Pressure | Orifice no. | Manifold Pressure | Orifice no. | Manifold Pressure |
| U.S.A. and Canada 0 to 2000 | 850 | 43 | 3.7 | 43 | 3.8 | 42 | 3.2 | 42 | 3.3 | 42 | 3.4 |
| | 875 | 43 | 3.5 | 43 | 3.6 | 43 | 3.7 | 43 | 3.8 | 42 | 3.2 |
| | 900 | 44 | 3.7 | 43 | 3.4 | 43 | 3.5 | 43 | 3.6 | 43 | 3.7 |
| | 925 | 44 | 3.5 | 44 | 3.7 | 44 | 3.8 | 43 | 3.4 | 43 | 3.5 |
| | 950 | 44 | 3.4 | 44 | 3.5 | 44 | 3.6 | 44 | 3.7 | 44 | 3.8 |
| | 975 | 44 | 3.2 | 44 | 3.3 | 44 | 3.4 | 44 | 3.5 | 44 | 3.6 |
| | 1000 | 45 | 3.7 | 45 | 3.8 | 44 | 3.2 | 44 | 3.4 | 44 | 3.5 |
| | 1025 | 45 | 3.5 | 45 | 3.6 | 45 | 3.7 | 44 | 3.2 | 44 | 3.3 |
| | 1050 | 45 | 3.3 | 45 | 3.4 | 45 | 3.6 | 45 | 3.7 | 45 | 3.8 |
| | 1075 | 45 | 3.2 | 45 | 3.3 | 45 | 3.4 | 45 | 3.5 | 45 | 3.6 |
| 1100 | 47 | 3.6 | 47 | 3.7 | 45 | 3.2 | 45 | 3.4 | 45 | 3.5 | |
| ALTIMUDE RANGE (FT) | AVG GAS HEAT VALUE (BTU/CU FT) | SPECIFIC GRAVITY OF NATURAL GAS | | | | | | | | | |
| | | 0.58 | | 0.60 | | 0.62 | | 0.64 | | 0.66 | |
| | | Orifice no. | Manifold Pressure | Orifice no. | Manifold Pressure | Orifice no. | Manifold Pressure | Orifice no. | Manifold Pressure | Orifice no. | Manifold Pressure |
| U.S.A. and Canada Altitudes 2001 to 3000 or Canada Altitudes 2000 to 4500 | 775 | 43 | 3.8 | 42 | 3.2 | 42 | 3.3 | 42 | 3.4 | 42 | 3.5 |
| | 800 | 43 | 3.5 | 43 | 3.7 | 43 | 3.8 | 42 | 3.2 | 42 | 3.3 |
| | 825 | 44 | 3.8 | 43 | 3.4 | 43 | 3.6 | 43 | 3.7 | 43 | 3.8 |
| | 850 | 44 | 3.6 | 44 | 3.7 | 44 | 3.8 | 43 | 3.5 | 43 | 3.6 |
| | 875 | 44 | 3.4 | 44 | 3.5 | 44 | 3.6 | 44 | 3.7 | 43 | 3.4 |
| | 900 | 44 | 3.2 | 44 | 3.3 | 44 | 3.4 | 44 | 3.5 | 44 | 3.6 |
| | 925 | 45 | 3.7 | 45 | 3.8 | 44 | 3.2 | 44 | 3.3 | 44 | 3.4 |
| | 950 | 45 | 3.5 | 45 | 3.6 | 45 | 3.7 | 45 | 3.8 | 44 | 3.3 |
| | 975 | 45 | 3.3 | 45 | 3.4 | 45 | 3.5 | 45 | 3.6 | 45 | 3.8 |
| | 1000 | 45 | 3.1 | 45 | 3.2 | 45 | 3.4 | 45 | 3.5 | 45 | 3.6 |
| 1025 | 45 | 3.0 | 45 | 3.1 | 45 | 3.2 | 45 | 3.3 | 45 | 3.4 | |
| ALTIMUDE RANGE (FT) | AVG GAS HEAT VALUE (BTU/CU FT) | SPECIFIC GRAVITY OF NATURAL GAS | | | | | | | | | |
| | | 0.58 | | 0.60 | | 0.62 | | 0.64 | | 0.66 | |
| | | Orifice no. | Manifold Pressure | Orifice no. | Manifold Pressure | Orifice no. | Manifold Pressure | Orifice no. | Manifold Pressure | Orifice no. | Manifold Pressure |
| U.S.A. Only 3001 to 4000 | 750 | 43 | 3.7 | 43 | 3.8 | 42 | 3.3 | 42 | 3.4 | 42 | 3.5 |
| | 775 | 43 | 3.5 | 43 | 3.6 | 43 | 3.7 | 43 | 3.8 | 42 | 3.2 |
| | 800 | 44 | 3.7 | 43 | 3.4 | 43 | 3.5 | 43 | 3.6 | 43 | 3.7 |
| | 825 | 44 | 3.5 | 44 | 3.6 | 44 | 3.8 | 43 | 3.4 | 43 | 3.5 |
| | 850 | 44 | 3.3 | 44 | 3.4 | 44 | 3.5 | 44 | 3.7 | 44 | 3.8 |
| | 875 | 45 | 3.8 | 44 | 3.2 | 44 | 3.3 | 44 | 3.5 | 44 | 3.6 |
| | 900 | 45 | 3.6 | 45 | 3.7 | 45 | 3.8 | 44 | 3.3 | 44 | 3.4 |
| | 925 | 45 | 3.4 | 45 | 3.5 | 45 | 3.6 | 45 | 3.7 | 44 | 3.2 |
| | 950 | 45 | 3.2 | 45 | 3.3 | 45 | 3.4 | 45 | 3.5 | 45 | 3.7 |
| | 975 | 45 | 3.0 | 45 | 3.2 | 45 | 3.3 | 45 | 3.4 | 45 | 3.5 |
| 1000 | 45 | 2.9 | 45 | 3.0 | 45 | 3.1 | 45 | 3.2 | 45 | 3.3 | |

* Orifice numbers 45 are factory installed.

**TABLE 9—MODEL 350MAV ORIFICE SIZE AND MANIFOLD PRESSURE FOR CORRECT INPUT (CONTINUED)
FOR USE WITH 040 THROUGH 120 SIZE FURNACES ONLY
(TABULATED DATA BASED ON 20,000 BTUH PER BURNER, DERATED 2 PERCENT FOR EACH 1000 FT ABOVE SEA LEVEL)**

| ALTITUDE RANGE (FT) | | AVG GAS HEAT VALUE (BTU/CU FT) | SPECIFIC GRAVITY OF NATURAL GAS | | | | | | | | | |
|---------------------|--------------|--------------------------------|---------------------------------|-------------------|-------------|-------------------|-------------|-------------------|-------------|-------------------|-------------|-------------------|
| | | | 0.58 | | 0.60 | | 0.62 | | 0.64 | | 0.66 | |
| | | | Orifice no. | Manifold Pressure | Orifice no. | Manifold Pressure | Orifice no. | Manifold Pressure | Orifice no. | Manifold Pressure | Orifice no. | Manifold Pressure |
| U.S.A. and Canada | 4001 to 5000 | 750 | 43 | 3.4 | 43 | 3.5 | 43 | 3.7 | 43 | 3.8 | 42 | 3.2 |
| | | 775 | 44 | 3.7 | 44 | 3.8 | 43 | 3.4 | 43 | 3.5 | 43 | 3.7 |
| | | 800 | 44 | 3.5 | 44 | 3.6 | 44 | 3.7 | 44 | 3.8 | 43 | 3.4 |
| | | 825 | 44 | 3.2 | 44 | 3.4 | 44 | 3.5 | 44 | 3.6 | 44 | 3.7 |
| | | 850 | 45 | 3.7 | 45 | 3.8 | 44 | 3.3 | 44 | 3.4 | 44 | 3.5 |
| | | 875 | 45 | 3.5 | 45 | 3.6 | 45 | 3.7 | 44 | 3.2 | 44 | 3.3 |
| | | 900 | 45 | 3.3 | 45 | 3.4 | 45 | 3.5 | 45 | 3.6 | 45 | 3.8 |
| | | 925 | 45 | 3.1 | 45 | 3.2 | 45 | 3.3 | 45 | 3.4 | 45 | 3.6 |
| | | 950 | 45 | 3.0 | 45 | 3.1 | 45 | 3.2 | 45 | 3.3 | 45 | 3.4 |
| U.S.A. and Canada | 5001 to 6000 | 725 | 43 | 3.4 | 43 | 3.5 | 43 | 3.6 | 43 | 3.7 | 43 | 3.8 |
| | | 750 | 44 | 3.6 | 44 | 3.7 | 43 | 3.4 | 43 | 3.5 | 43 | 3.6 |
| | | 775 | 44 | 3.4 | 44 | 3.5 | 44 | 3.6 | 44 | 3.7 | 43 | 3.4 |
| | | 800 | 44 | 3.2 | 44 | 3.3 | 44 | 3.4 | 44 | 3.5 | 44 | 3.6 |
| | | 825 | 45 | 3.6 | 45 | 3.7 | 44 | 3.2 | 44 | 3.3 | 44 | 3.4 |
| | | 850 | 45 | 3.4 | 45 | 3.5 | 45 | 3.6 | 45 | 3.8 | 44 | 3.2 |
| | | 875 | 45 | 3.2 | 45 | 3.3 | 45 | 3.4 | 45 | 3.6 | 45 | 3.7 |
| | | 900 | 45 | 3.0 | 45 | 3.1 | 45 | 3.3 | 45 | 3.4 | 45 | 3.5 |
| | | 925 | 45 | 2.9 | 45 | 3.0 | 45 | 3.1 | 45 | 3.2 | 45 | 3.3 |
| | | 950 | 45 | 2.7 | 45 | 2.8 | 45 | 2.9 | 45 | 3.0 | 45 | 3.1 |
| | | 975 | 45 | 2.6 | 45 | 2.7 | 45 | 2.8 | 45 | 2.9 | 45 | 2.9 |
| | | 1000 | 45 | 2.5 | 45 | 2.5 | 45 | 2.6 | 45 | 2.7 | 45 | 2.8 |
| U.S.A. Only | 6001 to 7000 | 675 | 43 | 3.6 | 43 | 3.7 | 43 | 3.8 | 42 | 3.2 | 42 | 3.3 |
| | | 700 | 44 | 3.8 | 43 | 3.4 | 43 | 3.6 | 43 | 3.7 | 43 | 3.8 |
| | | 725 | 44 | 3.6 | 44 | 3.7 | 44 | 3.8 | 43 | 3.4 | 43 | 3.5 |
| | | 750 | 44 | 3.3 | 44 | 3.4 | 44 | 3.6 | 44 | 3.7 | 44 | 3.8 |
| | | 775 | 45 | 3.8 | 44 | 3.2 | 44 | 3.3 | 44 | 3.4 | 44 | 3.5 |
| | | 800 | 45 | 3.5 | 45 | 3.7 | 45 | 3.8 | 44 | 3.2 | 44 | 3.3 |
| | | 825 | 45 | 3.3 | 45 | 3.4 | 45 | 3.6 | 45 | 3.7 | 45 | 3.8 |
| | | 850 | 45 | 3.1 | 45 | 3.2 | 45 | 3.4 | 45 | 3.5 | 45 | 3.6 |
| | | 875 | 45 | 3.0 | 45 | 3.1 | 45 | 3.2 | 45 | 3.3 | 45 | 3.4 |

* Orifice numbers 45 are factory installed.

**TABLE 9—MODEL 350MAV ORIFICE SIZE AND MANIFOLD PRESSURE FOR CORRECT INPUT (CONTINUED)
FOR USE WITH 040 THROUGH 120 SIZE FURNACES ONLY
(TABULATED DATA BASED ON 20,000 BTUH PER BURNER, DERATED 2 PERCENT FOR EACH 1000 FT ABOVE SEA LEVEL)**

| ALTITUDE RANGE (FT) | AVG GAS HEAT VALUE (BTU/CU FT) | SPECIFIC GRAVITY OF NATURAL GAS | | | | | | | | | | |
|---------------------|--------------------------------|---------------------------------|-------------------|-------------|-------------------|-------------|-------------------|-------------|-------------------|-------------|-------------------|-----|
| | | 0.58 | | 0.60 | | 0.62 | | 0.64 | | 0.66 | | |
| | | Orifice no. | Manifold Pressure | Orifice no. | Manifold Pressure | Orifice no. | Manifold Pressure | Orifice no. | Manifold Pressure | Orifice no. | Manifold Pressure | |
| U.S.A. Only | 7001 to 8000 | 650 | 43 | 3.5 | 43 | 3.7 | 43 | 3.8 | 42 | 3.2 | 42 | 3.3 |
| | | 675 | 44 | 3.8 | 43 | 3.4 | 43 | 3.5 | 43 | 3.6 | 43 | 3.7 |
| | | 700 | 44 | 3.5 | 44 | 3.6 | 44 | 3.8 | 43 | 3.4 | 43 | 3.5 |
| | | 725 | 44 | 3.3 | 44 | 3.4 | 44 | 3.5 | 44 | 3.6 | 44 | 3.7 |
| | | 750 | 45 | 3.7 | 45 | 3.8 | 44 | 3.3 | 44 | 3.4 | 44 | 3.5 |
| | | 775 | 45 | 3.5 | 45 | 3.6 | 45 | 3.7 | 45 | 3.8 | 44 | 3.3 |
| | | 800 | 45 | 3.3 | 45 | 3.4 | 45 | 3.5 | 45 | 3.6 | 45 | 3.7 |
| | | 825 | 45 | 3.1 | 45 | 3.2 | 45 | 3.3 | 45 | 3.4 | 45 | 3.5 |
| | 850 | 45 | 2.9 | 45 | 3.0 | 45 | 3.1 | 45 | 3.2 | 45 | 3.3 | |
| ALTITUDE RANGE (FT) | AVG GAS HEAT VALUE (BTU/CU FT) | SPECIFIC GRAVITY OF NATURAL GAS | | | | | | | | | | |
| | | 0.58 | | 0.60 | | 0.62 | | 0.64 | | 0.66 | | |
| | | Orifice no. | Manifold Pressure | Orifice no. | Manifold Pressure | Orifice no. | Manifold Pressure | Orifice no. | Manifold Pressure | Orifice no. | Manifold Pressure | |
| U.S.A. Only | Altitudes 8001 to 9000 | 625 | 43 | 3.5 | 43 | 3.6 | 43 | 3.8 | 42 | 3.2 | 42 | 3.3 |
| | | 650 | 44 | 3.7 | 43 | 3.4 | 43 | 3.5 | 43 | 3.6 | 43 | 3.7 |
| | | 675 | 44 | 3.5 | 44 | 3.6 | 44 | 3.7 | 44 | 3.8 | 43 | 3.4 |
| | | 700 | 44 | 3.2 | 44 | 3.3 | 44 | 3.4 | 44 | 3.6 | 44 | 3.7 |
| | | 725 | 45 | 3.6 | 45 | 3.8 | 44 | 3.2 | 44 | 3.3 | 44 | 3.4 |
| | | 750 | 45 | 3.4 | 45 | 3.5 | 45 | 3.6 | 45 | 3.8 | 44 | 3.2 |
| | | 775 | 45 | 3.2 | 45 | 3.3 | 45 | 3.4 | 45 | 3.5 | 45 | 3.6 |
| | | 800 | 45 | 3.0 | 45 | 3.1 | 45 | 3.2 | 45 | 3.3 | 45 | 3.4 |
| ALTITUDE RANGE (FT) | AVG GAS HEAT VALUE (BTU/CU FT) | SPECIFIC GRAVITY OF NATURAL GAS | | | | | | | | | | |
| | | 0.58 | | 0.60 | | 0.62 | | 0.64 | | 0.66 | | |
| | | Orifice no. | Manifold Pressure | Orifice no. | Manifold Pressure | Orifice no. | Manifold Pressure | Orifice no. | Manifold Pressure | Orifice no. | Manifold Pressure | |
| U.S.A. Only | 9001 to 10,000 | 600 | 43 | 3.5 | 43 | 3.6 | 43 | 3.7 | 42 | 3.2 | 42 | 3.3 |
| | | 625 | 44 | 3.7 | 44 | 3.8 | 43 | 3.5 | 43 | 3.6 | 43 | 3.7 |
| | | 650 | 44 | 3.4 | 44 | 3.5 | 44 | 3.7 | 44 | 3.8 | 43 | 3.4 |
| | | 675 | 44 | 3.8 | 44 | 3.3 | 44 | 3.4 | 44 | 3.5 | 44 | 3.6 |
| | | 700 | 45 | 3.6 | 45 | 3.7 | 45 | 3.8 | 44 | 3.3 | 44 | 3.4 |
| | | 725 | 45 | 3.3 | 45 | 3.4 | 45 | 3.6 | 45 | 3.7 | 45 | 3.8 |
| | | 750 | 45 | 3.1 | 45 | 3.2 | 45 | 3.3 | 45 | 3.4 | 45 | 3.5 |
| | | 775 | 45 | 2.9 | 45 | 3.0 | 45 | 3.1 | 45 | 3.2 | 45 | 3.3 |

*Orifice numbers 45 are factory installed.

**TABLE 10—MODEL 350MAV ORIFICE SIZE AND MANIFOLD PRESSURE FOR CORRECT INPUT
FOR USE WITH 140 THROUGH 120 SIZE FURNACES ONLY
(TABULATED DATA BASED ON 23,000 BTUH PER BURNER, DERATED 2 PERCENT FOR EACH 1000 FT ABOVE SEA LEVEL)**

| ALTIUDE RANGE (FT) | AVG GAS HEAT VALUE (BTU/CU FT) | SPECIFIC GRAVITY OF NATURAL GAS | | | | | | | | | |
|--|--------------------------------|---------------------------------|-------------------|-------------|-------------------|-------------|-------------------|-------------|-------------------|-------------|-------------------|
| | | 0.58 | | 0.60 | | 0.62 | | 0.64 | | 0.66 | |
| | | Orifice no. | Manifold Pressure | Orifice no. | Manifold Pressure | Orifice no. | Manifold Pressure | Orifice no. | Manifold Pressure | Orifice no. | Manifold Pressure |
| U.S.A. and Canada 0 to 2000 | 850 | 41 | 3.6 | 41 | 3.7 | 41 | 3.8 | 40 | 3.6 | 40 | 3.8 |
| | 875 | 42 | 3.8 | 41 | 3.5 | 41 | 3.6 | 41 | 3.7 | 41 | 3.8 |
| | 900 | 42 | 3.5 | 42 | 3.7 | 42 | 3.8 | 41 | 3.5 | 41 | 3.6 |
| | 925 | 42 | 3.4 | 42 | 3.5 | 42 | 3.6 | 42 | 3.7 | 42 | 3.8 |
| | 950 | 42 | 3.2 | 42 | 3.3 | 42 | 3.4 | 42 | 3.5 | 42 | 3.6 |
| | 975 | 43 | 3.7 | 43 | 3.8 | 42 | 3.2 | 42 | 3.3 | 42 | 3.4 |
| | 1000 | 43 | 3.5 | 43 | 3.6 | 43 | 3.7 | 42 | 3.2 | 42 | 3.3 |
| | 1025 | 43 | 3.3 | 43 | 3.4 | 43 | 3.6 | 43 | 3.7 | 43 | 3.8 |
| | 1050 | 43 | 3.2 | 43 | 3.3 | 43 | 3.4 | 43 | 3.5 | 43 | 3.6 |
| | 1075 | 44 | 3.5 | 44 | 3.6 | 43 | 3.2 | 43 | 3.3 | 43 | 3.4 |
| 1100 | 44 | 3.3 | 44 | 3.4 | 44 | 3.5 | 43 | 3.2 | 43 | 3.3 | |
| ALTIUDE RANGE (FT) | AVG GAS HEAT VALUE (BTU/CU FT) | SPECIFIC GRAVITY OF NATURAL GAS | | | | | | | | | |
| | | 0.58 | | 0.60 | | 0.62 | | 0.64 | | 0.66 | |
| | | Orifice no. | Manifold Pressure | Orifice no. | Manifold Pressure | Orifice no. | Manifold Pressure | Orifice no. | Manifold Pressure | Orifice no. | Manifold Pressure |
| U.S.A. and Canada Altitudes 2001 to 3000 or Canada Altitudes 2000 to 4500 | 775 | 41 | 3.7 | 41 | 3.8 | 40 | 3.6 | 40 | 3.7 | 39 | 3.6 |
| | 800 | 42 | 3.8 | 41 | 3.6 | 41 | 3.7 | 41 | 3.8 | 40 | 3.6 |
| | 825 | 42 | 3.6 | 42 | 3.7 | 41 | 3.5 | 41 | 3.6 | 41 | 3.7 |
| | 850 | 42 | 3.4 | 42 | 3.5 | 42 | 3.6 | 42 | 3.7 | 41 | 3.5 |
| | 875 | 42 | 3.2 | 42 | 3.3 | 42 | 3.4 | 42 | 3.5 | 42 | 3.6 |
| | 900 | 43 | 3.7 | 43 | 3.8 | 42 | 3.2 | 42 | 3.3 | 42 | 3.4 |
| | 925 | 43 | 3.5 | 43 | 3.6 | 43 | 3.7 | 42 | 3.2 | 42 | 3.3 |
| | 950 | 43 | 3.3 | 43 | 3.4 | 43 | 3.5 | 43 | 3.7 | 43 | 3.8 |
| | 975 | 43 | 3.1 | 43 | 3.3 | 43 | 3.4 | 43 | 3.5 | 43 | 3.6 |
| | 1000 | 43 | 3.0 | 43 | 3.1 | 43 | 3.2 | 43 | 3.3 | 43 | 3.4 |
| 1025 | 43 | 2.8 | 43 | 2.9 | 43 | 3.0 | 43 | 3.1 | 43 | 3.2 | |
| ALTIUDE RANGE (FT) | AVG GAS HEAT VALUE (BTU/CU FT) | SPECIFIC GRAVITY OF NATURAL GAS | | | | | | | | | |
| | | 0.58 | | 0.60 | | 0.62 | | 0.64 | | 0.66 | |
| | | Orifice no. | Manifold Pressure | Orifice no. | Manifold Pressure | Orifice no. | Manifold Pressure | Orifice no. | Manifold Pressure | Orifice no. | Manifold Pressure |
| U.S.A. Only 3001 to 4000 | 750 | 41 | 3.6 | 41 | 3.8 | 40 | 3.6 | 40 | 3.7 | 40 | 3.8 |
| | 775 | 42 | 3.8 | 41 | 3.5 | 41 | 3.6 | 41 | 3.7 | 40 | 3.6 |
| | 800 | 42 | 3.5 | 42 | 3.7 | 42 | 3.8 | 41 | 3.5 | 41 | 3.6 |
| | 825 | 42 | 3.3 | 42 | 3.4 | 42 | 3.6 | 42 | 3.7 | 42 | 3.8 |
| | 850 | 43 | 3.8 | 42 | 3.2 | 42 | 3.4 | 42 | 3.5 | 42 | 3.6 |
| | 875 | 43 | 3.6 | 43 | 3.7 | 42 | 3.2 | 42 | 3.3 | 42 | 3.4 |
| | 900 | 43 | 3.4 | 43 | 3.5 | 43 | 3.6 | 43 | 3.8 | 42 | 3.2 |
| | 925 | 43 | 3.2 | 43 | 3.3 | 43 | 3.5 | 43 | 3.6 | 43 | 3.7 |
| | 950 | 43 | 3.1 | 43 | 3.2 | 43 | 3.3 | 43 | 3.4 | 43 | 3.5 |
| | 975 | 43 | 2.9 | 43 | 3.0 | 43 | 3.1 | 43 | 3.2 | 43 | 3.3 |
| 1000 | 43 | 2.8 | 43 | 2.9 | 43 | 3.0 | 43 | 3.0 | 43 | 3.1 | |

* Orifice numbers 43 are factory installed.

**TABLE 10—MODEL 350MAV ORIFICE SIZE AND MANIFOLD PRESSURE FOR CORRECT INPUT (CONTINUED)
FOR USE WITH 140 THROUGH 120 SIZE FURNACES ONLY
(TABULATED DATA BASED ON 23,000 BTUH PER BURNER, DERATED 2 PERCENT FOR EACH 1000 FT ABOVE SEA LEVEL)**

| ALTITUDE RANGE (FT) | | AVG GAS HEAT VALUE (BTU/CU FT) | SPECIFIC GRAVITY OF NATURAL GAS | | | | | | | | | |
|---------------------|--------------|--------------------------------|---------------------------------|-------------------|-------------|-------------------|-------------|-------------------|-------------|-------------------|-------------|-------------------|
| | | | 0.58 | | 0.60 | | 0.62 | | 0.64 | | 0.66 | |
| | | | Orifice no. | Manifold Pressure | Orifice no. | Manifold Pressure | Orifice no. | Manifold Pressure | Orifice no. | Manifold Pressure | Orifice no. | Manifold Pressure |
| U.S.A. and Canada | 4001 to 5000 | 725 | 41 | 3.6 | 41 | 3.7 | 41 | 3.8 | 40 | 3.6 | 40 | 3.8 |
| | | 750 | 42 | 3.7 | 42 | 3.8 | 41 | 3.6 | 41 | 3.7 | 41 | 3.8 |
| | | 775 | 42 | 3.5 | 42 | 3.6 | 42 | 3.7 | 42 | 3.8 | 41 | 3.6 |
| | | 800 | 42 | 3.3 | 42 | 3.4 | 42 | 3.5 | 42 | 3.6 | 42 | 3.7 |
| | | 825 | 42 | 3.7 | 42 | 3.2 | 42 | 3.3 | 42 | 3.4 | 42 | 3.5 |
| | | 850 | 43 | 3.5 | 43 | 3.6 | 43 | 3.8 | 42 | 3.2 | 42 | 3.3 |
| | | 875 | 43 | 3.3 | 43 | 3.4 | 43 | 3.6 | 43 | 3.7 | 43 | 3.8 |
| | | 900 | 43 | 3.1 | 43 | 3.3 | 43 | 3.4 | 43 | 3.5 | 43 | 3.6 |
| | | 925 | 43 | 3.0 | 43 | 3.1 | 43 | 3.2 | 43 | 3.3 | 43 | 3.4 |
| | | 950 | 43 | 2.8 | 43 | 3.9 | 43 | 3.0 | 43 | 3.1 | 43 | 3.2 |
| U.S.A. and Canada | 5001 to 6000 | 700 | 41 | 3.5 | 41 | 3.7 | 41 | 3.8 | 40 | 3.6 | 40 | 3.7 |
| | | 725 | 42 | 3.7 | 42 | 3.8 | 41 | 3.5 | 41 | 3.6 | 41 | 3.8 |
| | | 750 | 42 | 3.4 | 42 | 3.5 | 42 | 3.7 | 42 | 3.8 | 41 | 3.5 |
| | | 775 | 42 | 3.2 | 42 | 3.3 | 42 | 3.4 | 42 | 3.5 | 42 | 3.7 |
| | | 800 | 43 | 3.7 | 43 | 3.8 | 42 | 3.2 | 42 | 3.3 | 42 | 3.4 |
| | | 825 | 43 | 3.5 | 43 | 3.6 | 43 | 3.7 | 43 | 3.8 | 42 | 3.2 |
| | | 850 | 43 | 3.3 | 43 | 3.4 | 43 | 3.5 | 43 | 3.6 | 43 | 3.7 |
| | | 875 | 43 | 3.1 | 43 | 3.2 | 43 | 3.3 | 43 | 3.4 | 43 | 3.5 |
| | | 900 | 43 | 2.9 | 43 | 3.0 | 43 | 3.1 | 43 | 3.2 | 43 | 3.3 |
| | | 925 | 43 | 2.7 | 43 | 2.8 | 43 | 2.9 | 43 | 3.0 | 43 | 3.1 |
| | | 950 | 43 | 2.6 | 43 | 2.7 | 43 | 2.8 | 43 | 2.9 | 43 | 3.0 |
| | | | | 975 | 43 | 2.5 | 43 | 2.6 | 43 | 2.6 | 43 | 2.7 |
| | | 1000 | 43 | 2.3 | 43 | 2.4 | 43 | 2.5 | 43 | 2.6 | 43 | 2.7 |
| U.S.A. Only | 6001 to 7000 | 650 | 41 | 3.8 | 40 | 3.6 | 40 | 3.7 | 40 | 3.8 | 39 | 3.7 |
| | | 675 | 41 | 3.5 | 41 | 3.6 | 41 | 3.7 | 40 | 3.6 | 40 | 3.7 |
| | | 700 | 42 | 3.6 | 42 | 3.7 | 41 | 3.5 | 41 | 3.6 | 41 | 3.7 |
| | | 725 | 42 | 3.4 | 42 | 3.5 | 42 | 3.6 | 42 | 3.7 | 42 | 3.8 |
| | | 750 | 43 | 3.8 | 42 | 3.3 | 42 | 3.4 | 42 | 3.5 | 42 | 3.6 |
| | | 775 | 43 | 3.6 | 43 | 3.7 | 43 | 3.8 | 42 | 3.3 | 42 | 3.4 |
| | | 800 | 43 | 3.4 | 43 | 3.5 | 43 | 3.6 | 43 | 3.7 | 43 | 3.8 |
| | | 825 | 43 | 3.2 | 43 | 3.3 | 43 | 3.4 | 43 | 3.5 | 43 | 3.6 |
| | | 850 | 43 | 3.0 | 43 | 3.1 | 43 | 3.2 | 43 | 3.3 | 43 | 3.4 |
| | | | | 875 | 43 | 2.8 | 43 | 2.9 | 43 | 3.0 | 43 | 3.1 |

*Orifice numbers 43 are factory installed.

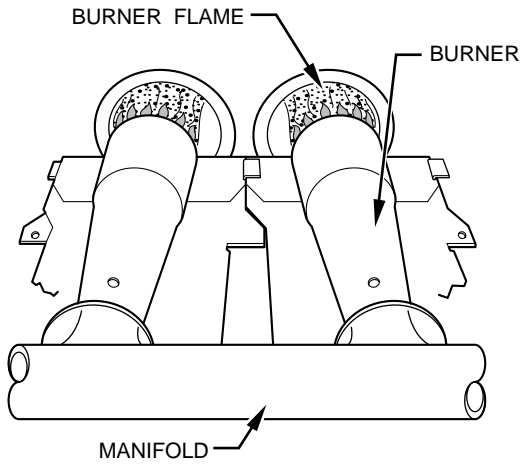

A89020

Fig. 52—Burner Flame

EXAMPLE: (0-2000 ft altitude)
 Furnace input from rating plate is 100,000 Btuh.
 Btu heating input = Btu/cu ft X cu ft/hr
 Heating value of gas = 975 Btu/cu ft
 Time for 1 revolution of 2-cu ft dial = 70 sec
 Gas rate = 103 cu ft/hr (from Table 12)
 Btu heating input = 103 X 975 = 100,425 Btuh. In this example, the orifice size and manifold pressure adjustment is within ±2 percent of the furnace input rate.

TABLE 12—GAS RATE (CU FT/HR)

| SECONDS FOR 1 REVOLUTION | SIZE OF TEST DIAL | | | SECONDS FOR 1 REVOLUTION | SIZE OF TEST DIAL | | |
|--------------------------|-------------------|---------|---------|--------------------------|-------------------|---------|---------|
| | 1 Cu Ft | 2 Cu Ft | 5 Cu Ft | | 1 Cu Ft | 2 Cu Ft | 5 Cu Ft |
| 10 | 360 | 720 | 1800 | 50 | 72 | 144 | 360 |
| 11 | 327 | 655 | 1636 | 51 | 71 | 141 | 355 |
| 12 | 300 | 600 | 1500 | 52 | 69 | 138 | 346 |
| 13 | 277 | 555 | 1385 | 53 | 68 | 136 | 340 |
| 14 | 257 | 514 | 1286 | 54 | 67 | 133 | 333 |
| 15 | 240 | 480 | 1200 | 55 | 65 | 131 | 327 |
| 16 | 225 | 450 | 1125 | 56 | 64 | 129 | 321 |
| 17 | 212 | 424 | 1059 | 57 | 63 | 126 | 316 |
| 18 | 200 | 400 | 1000 | 58 | 62 | 124 | 310 |
| 19 | 189 | 379 | 947 | 59 | 61 | 122 | 305 |
| 20 | 180 | 360 | 900 | 60 | 60 | 120 | 300 |
| 21 | 171 | 343 | 857 | 62 | 58 | 116 | 290 |
| 22 | 164 | 327 | 818 | 64 | 56 | 112 | 281 |
| 23 | 157 | 313 | 783 | 66 | 54 | 109 | 273 |
| 24 | 150 | 300 | 750 | 68 | 53 | 106 | 265 |
| 25 | 144 | 288 | 720 | 70 | 51 | 103 | 257 |
| 26 | 138 | 277 | 692 | 72 | 50 | 100 | 250 |
| 27 | 133 | 267 | 667 | 74 | 48 | 97 | 243 |
| 28 | 129 | 257 | 643 | 76 | 47 | 95 | 237 |
| 29 | 124 | 248 | 621 | 78 | 46 | 92 | 231 |
| 30 | 120 | 240 | 600 | 80 | 45 | 90 | 225 |
| 31 | 116 | 232 | 581 | 82 | 44 | 88 | 220 |
| 32 | 113 | 225 | 563 | 84 | 43 | 86 | 214 |
| 33 | 109 | 218 | 545 | 86 | 42 | 84 | 209 |
| 34 | 106 | 212 | 529 | 88 | 41 | 82 | 205 |
| 35 | 103 | 206 | 514 | 90 | 40 | 80 | 200 |
| 36 | 100 | 200 | 500 | 92 | 39 | 78 | 196 |
| 37 | 97 | 195 | 486 | 94 | 38 | 76 | 192 |
| 38 | 95 | 189 | 474 | 96 | 38 | 75 | 188 |
| 39 | 92 | 185 | 462 | 98 | 37 | 74 | 184 |
| 40 | 90 | 180 | 450 | 100 | 36 | 72 | 180 |
| 41 | 88 | 176 | 439 | 102 | 35 | 71 | 178 |
| 42 | 86 | 172 | 429 | 104 | 35 | 69 | 173 |
| 43 | 84 | 167 | 419 | 106 | 34 | 68 | 170 |
| 44 | 82 | 164 | 409 | 108 | 33 | 67 | 167 |
| 45 | 80 | 160 | 400 | 110 | 33 | 65 | 164 |
| 46 | 78 | 157 | 391 | 112 | 32 | 64 | 161 |
| 47 | 76 | 153 | 383 | 116 | 31 | 62 | 155 |
| 48 | 75 | 150 | 375 | 120 | 30 | 60 | 150 |
| 49 | 73 | 147 | 367 | | | | |

EXAMPLE:
 100,000 Btuh input furnace installed at 4300 ft.
 Furnace Input Rate at Sea Level X Derate Multiplier Factor = Furnace Input Rate at Installation Altitude
 100,000 X 0.91 = 91,000

TABLE 11—ALTITUDE DERATE MULTIPLIER FOR U.S.A.

| ALTITUDE (FT) | PERCENT OF DERATE | DERATE MULTIPLIER FACTOR FOR U.S.A.* |
|---------------|-------------------|--------------------------------------|
| 0-2000 | 0 | 1.00 |
| 2001-3000 | 4-6 | 0.95 |
| 3001-4000 | 6-8 | 0.93 |
| 4001-5000 | 8-10 | 0.91 |
| 5001-6000 | 10-12 | 0.89 |
| 6001-7000 | 12-14 | 0.87 |
| 7001-8000 | 14-16 | 0.85 |
| 8001-9000 | 16-18 | 0.83 |
| 9001-10,000 | 18-20 | 0.81 |

* Derate multiplier factor is based on midpoint altitude for altitude range.

- d. Measure time (in sec) for gas meter test dial 1 revolution.
- e. Refer to Table 12 for cu ft of gas per hr.
- f. Multiply gas rate (cu ft/hr) X heating value (Btu/cu ft) using natural gas heating value from local gas utility/supplier.

B. Set Temperature Rise

CAUTION: Temperature rise must be within limits specified on unit rating plate. Recommended operation is at midpoint of rise or slightly above. Failure to follow this caution may result in condensing or overheating the heat exchangers.

Determine and adjust air temperature rise as follows:

1. Place thermometers in return and supply ducts as close to furnace as possible. Be sure thermometers do not see heat exchanger so that radiant heat does not affect readings. This practice is particularly important with straight-run ducts.
2. When thermometer dings stabilize, subtract return-air temperature from supply-air temperature to determine air temperature rise.
3. Adjust temperature rise by adjusting blower speed. Increase blower speed to reduce temperature rise. Decrease blower speed to increase temperature rise.

WARNING: Disconnect 115-v electrical power before changing speed tap. Failure to follow this warning could result in personal injury.

- To change blower motor speed selections for heating mode, remove blower motor lead from control center HEAT terminal. (See Fig. 31.) Select desired blower motor speed lead from 1 of the other terminals and relocate it to HEAT terminal. See Table 13 for lead color identification. Reconnect original lead on SPARE terminal. Follow this same procedure for proper selection of COOL speed selection.

TABLE 13—SPEED SELECTOR

| COLOR | SPEED | FACTORY-SHIPPED CONNECTION |
|-----------------------|-------------|----------------------------|
| Black | High | Cool |
| Yellow (When Present) | Medium High | Spare |
| Blue | Medium Low | Heat |
| Red | Low | Spare |
| White | Common | Com |

C. Adjust Blower Off Delay (Heat Mode)

If desired, the main blower off time delay period may be lengthened or shortened when operating in the heating mode to provide greater comfort. See Table 14 for position of switches and Fig. 30 or 31 for location of switches on control center.

TABLE 14—BLOWER OFF DELAY SETUP SWITCH POSITION

| DESIRED HEATING MODE BLOWER OFF DELAY (SEC) | SETUP SWITCH POSITION | |
|---|-----------------------|------|
| | SW-1 | SW-2 |
| 90 | OFF | OFF |
| 135 | ON | OFF |
| 180 | OFF | ON |
| 225 | ON | ON |

D. Set Thermostat Heat Anticipator

Thermostat heat anticipator must be set to match amp draw of components in R-W circuit. Accurate amp draw measurements can be obtained at thermostat subbase terminals R and W.

Fig. 53 illustrates an easy method of obtaining these measurements. Amp reading should be taken after blower motor has started. See thermostat manufacturer’s instructions for adjusting heat anticipator and for varying heating cycle length.

V. CHECK SAFETY CONTROLS

This section covers the safety controls that must be checked before the installation is complete.

A. Check Primary Limit Control

This control shuts off combustion control system and energizes air-circulating blower motor if furnace overheats. Recommended method of checking this limit control is to gradually block off return air after furnace has been operating for a period of at least 5 minutes. As soon as limit control has shut off burners, return-air opening should be unblocked to permit normal air circulation. By using this method to check limit control, it can be established that limit is functioning properly and operates if there is a restricted return-air supply or motor failure. If limit control does not function during this test, cause must be determined and corrected.

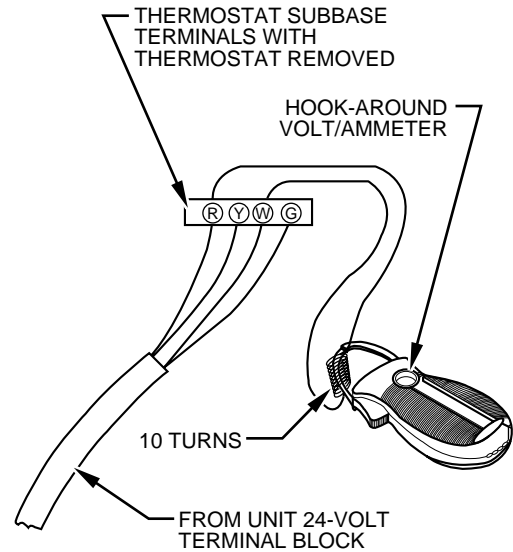

EXAMPLE: $\frac{5.0 \text{ AMPS ON AMMETER}}{10 \text{ TURNS AROUND JAWS}} = 0.5 \text{ AMPS FOR THERMOSTAT SETTING}$

A80201

Fig. 53—Amp Draw Check with Ammeter

B. Check Pressure Switch

This control proves operation of draft inducer. Check switch operation as follows:

- Turn off 115-v power to furnace.
- Remove main furnace door and disconnect inducer motor lead wires from wire harness.
- Turn on 115-v power to furnace.
- Set thermostat to call for heat and wait 1 minute. When pressure switch is functioning properly, hot surface ignitor should NOT glow, and control center diagnostic light flashes a Status Code 31. If hot surface ignitor glows when inducer motor is disconnected, shut furnace down immediately. Determine reason pressure switch did not function properly and correct condition.
- Turn off 115-v power to furnace.
- Reconnect inducer motor leads, reinstall main furnace door, and turn on 115-v power supply.

VI. CHECKLIST

- Put away tools and instruments. Clean up debris.
- Verify manual reset switch has continuity.
- Verify that blower and control access doors are properly installed.
- Cycle test furnace with room thermostat.
- Check operation of accessories per manufacturer’s instructions.
- Review User’s Guide with owner.
- Leave literature packet near furnace.

CHECKLIST—INSTALLATION

LOAD CALCULATION

_____ Heating Load (Btuh) _____

_____ Cooling Load (Btuh) _____

_____ Furnace Model Selection _____

COMBUSTION AND VENT PIPING

_____ Termination Location _____

_____ Roof or Sidewall _____

_____ Termination Kit — 2 Pipe or Concentric _____

_____ Combustion-Air Pipe Length _____

_____ Combustion-Air Elbow Quantity _____

_____ Vent Pipe Length _____

_____ Vent Pipe Elbow Quantity _____

_____ Pipe Diameter Determined from Sizing Table _____

_____ Pipe Sloped to Furnace _____

_____ Pipe Insulation _____

_____ Over Ceilings _____

_____ Low-Ambient Exposed Pipes _____

Condensate Drain
Unit Level or Pitched Forward

Internal Tubing Connections Free of Kinks and Traps

External Drain Connection Leak Tight and Sloped

Condensate Trap Primed before Start-Up

Heat Tape Installed if Required

CHECKLIST—START-UP

Gas Input Rate
(Set Within 2 percent of Rating Plate)

Temperature Rise Adjusted

Thermostat Anticipator

Anticipator Setting Adjusted or

Cycle Rate (3 Cycles per Hr) Selected

Safety Controls Check Operation

Primary Limit

Pressure Switch