

P-Type[®] Secondary Belt Cleaner

Installation, Operation and Maintenance Manual

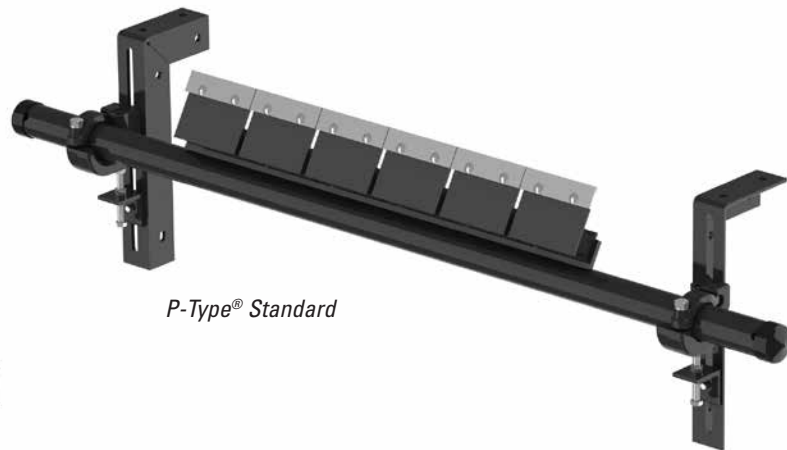

P-Type[®] Standard

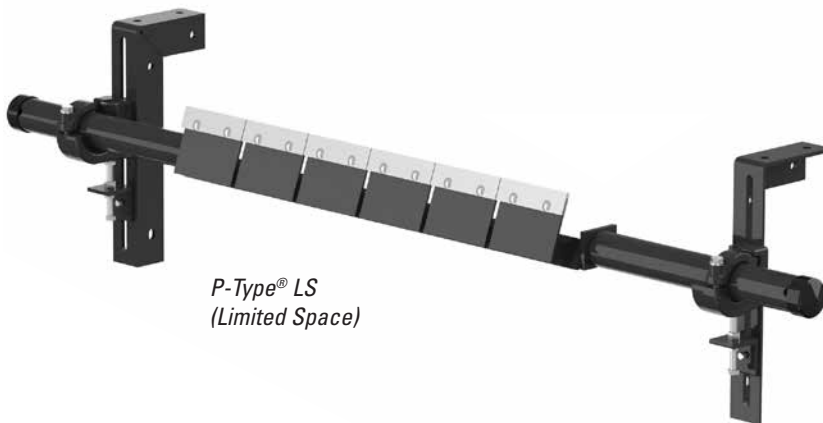

*P-Type[®] LS
(Limited Space)*

P-Type® Secondary Belt Cleaner

Purchase Date: _____

Purchased From: _____

Installation Date: _____

This information will be helpful for any future inquiries or questions about belt cleaner replacement parts, specifications or troubleshooting.

Table of Contents

Section 1 – Important Information	4
1.1 General Introduction	4
1.2 User Benefits	4
1.3 Service Option	4
Section 2 – Safety Considerations and Precautions	5
2.1 Stationary Conveyors	5
2.2 Operating Conveyors	5
Section 3 – Pre-Installation Checks and Options.....	6
3.1 Checklist	6
Section 4 – P-Type® and P-Type LS Belt Cleaner Installation Instructions	7
Section 5 – Pre-Operation Checklist and Testing.....	11
5.1 Pre-Op Checklist	11
5.2 Test Run the Conveyor	11
Section 6 – Maintenance	12
6.1 New Installation Inspection	12
6.2 Routine Visual Inspection	12
6.3 Routine Physical Inspection.....	12
6.4 Blade Replacement Instructions.....	13
6.5 Maintenance Log	15
6.6 Cleaner Maintenance Checklist.....	16
Section 7 – Troubleshooting	17
Section 8 – Specs and CAD Drawings.....	18
8.1 Specs and Guidelines	18
8.2 CAD Drawing - P-Type with C-Tips	19
8.3 CAD Drawing - P-Type with V-Tips	20
8.4 CAD Drawing - P-Type LS with C-Tips.....	21
Section 9 – Replacement Parts	22
Section 10 – Other Flexco Conveyor Products	23

Section 1 – Important Information

1.1 General Introduction

We at Flexco are very pleased that you have selected a P-Type® Secondary Belt Cleaner for your conveyor system.

This manual will help you to understand the operation of this product and assist you in making it work up to its maximum efficiency over its lifetime of service.

It is essential for safe and efficient operation that the information and guidelines presented be properly understood and implemented. This manual will provide safety precautions, installation instructions, maintenance procedures and troubleshooting tips.

If, however, you have any questions or problems that are not covered, please visit our web site or contact our Customer Service Department:

Customer Service: 612-8818-2000

Visit www.flexco.com for other Flexco locations and products.

Please read this manual thoroughly and pass it on to any others who will be directly responsible for installation, operation and maintenance of this product. While we have tried to make the installation and service tasks as easy and simple as possible, **it does however require correct installation and regular inspections and adjustments to maintain top working condition.**

1.2 User Benefits

Correct installation and regular maintenance will provide the following benefits for your operation:

- Reduced conveyor downtime
- Reduced man-hour labour
- Lower maintenance budget costs
- Increased service life for the belt cleaner and other conveyor components

1.3 Service Option

The P-Type® Secondary Belt Cleaner is designed to be easily installed and serviced by your on-site personnel. However, if you would prefer complete turn-key factory service, please contact your local Flexco Field Representative.

Section 2 – Safety Considerations and Precautions

Before installing and operating the P-Type® Secondary Belt Cleaner, it is important to review and understand the following safety information.

There are set-up, maintenance and operational activities involving both **stationary** and **operating** conveyors. Each case has a safety protocol.

2.1 Stationary Conveyors

The following activities are performed on stationary conveyors:

- Installation
- Blade replacement
- Repairs
- Tension adjustments
- Cleaning

DANGER

It is imperative that local Lockout/Tagout (LOTO) regulations be followed before undertaking the preceding activities. Failure to use LOTO exposes workers to uncontrolled behaviour of the belt cleaner caused by movement of the conveyor belt. Severe injury or death can result.

Before working:

- Lockout/Tagout the conveyor power source
- Disengage any takeups
- Clear the conveyor belt or clamp securely in place

WARNING

Use Personal Protective Equipment (PPE):

- Safety eyewear
- Hardhats
- Safety footwear

Close quarters, springs and heavy components create a worksite that compromises a worker's eyes, feet and skull.

PPE must be worn to control the foreseeable hazards associated with conveyor belt cleaners. Serious injuries can be avoided.

2.2 Operating Conveyors

There are two routine tasks that must be performed while the conveyor is running:

- Inspection of the cleaning performance
- Dynamic troubleshooting

DANGER

Every belt cleaner is an in-running nip hazard. Never touch or prod an operating cleaner. Cleaner hazards may cause instantaneous amputation and entrapment.

WARNING

Belt cleaners can become projectile hazards. Stay as far from the cleaner as practical and use safety eyewear and headgear. Missiles can inflict serious injury.

WARNING

Never adjust anything on an operating cleaner. Unforeseeable belt projections and tears can catch on cleaners and cause violent movements of the cleaner structure. Flailing hardware can cause serious injury or death.

Section 3 – Pre-installation Checks and Options

3.1 Checklist

- Check that the cleaner size is correct for the beltline width
- Check the belt cleaner carton and make sure all the parts are included
- Review the “Tools Needed” list on the top of the installation instructions
- Check the conveyor site:
 - Will the cleaner be installed on a chute
 - Is the install on an open head pulley requiring mounting structure

Section 4 – Installation Instructions

P-Type Secondary Belt Cleaner

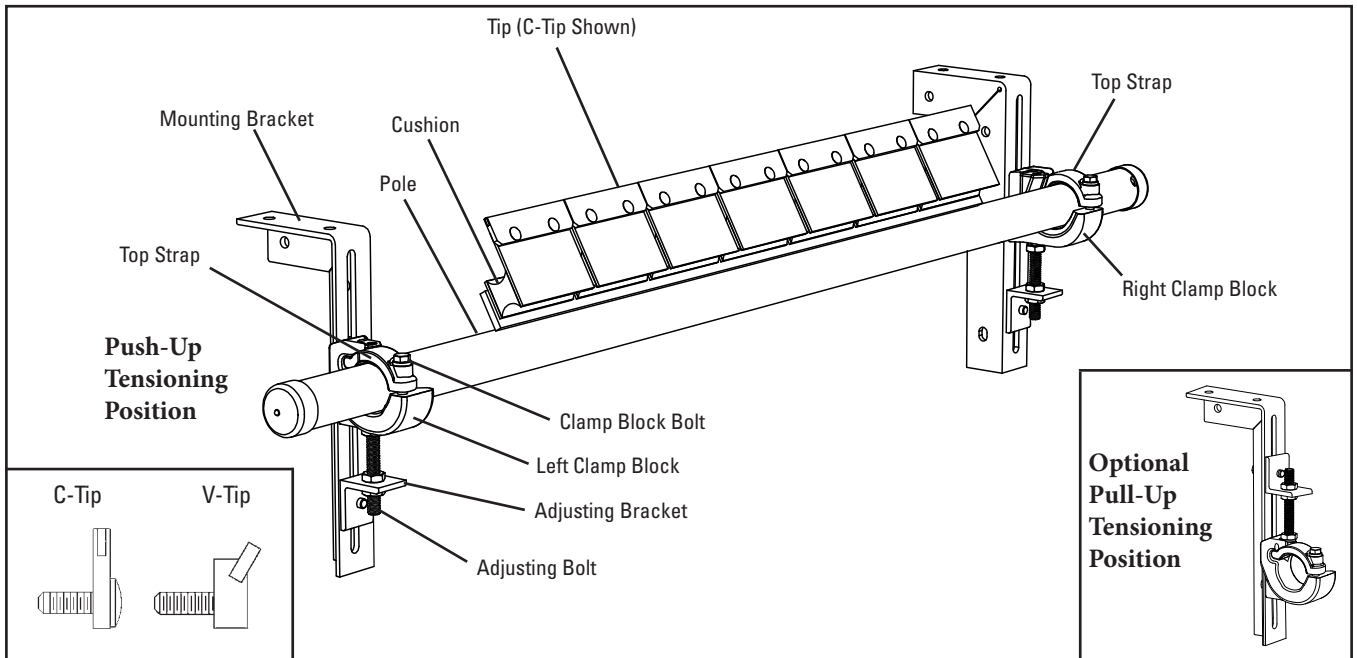

Physically lock out and tag the conveyor at the power source before you begin cleaner installation.

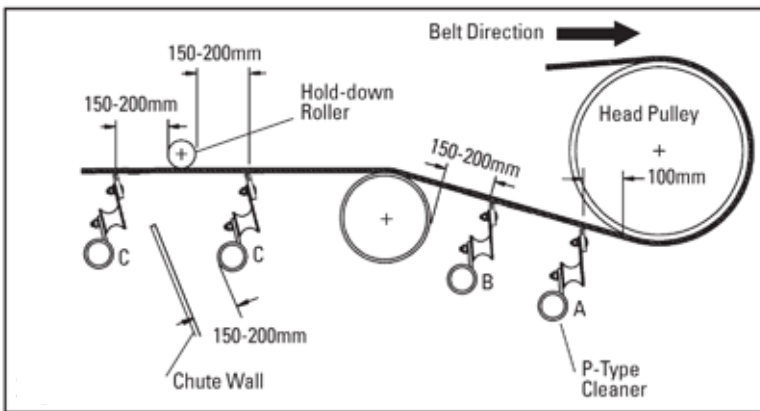

Tools Needed

- Tape Measure
- 19mm (3/4") Spanner
- Ratchet With 19mm (3/4") Socket
- (2) 150mm (6") C-Clamps (for Temporary Positioning of Mounting Brackets)
- Cutting Torch and/or Welder
- Marking Pen

Before You Begin:

- Double check the tip style needed for your application:
 C-Tip - for mechanically spliced and vulcanized belts.
 V-Tip - for vulcanized belts only.
- For chute mounting it may be necessary to cut an access hole to allow for installation and inspections. (See dimensions in STEP 2.)
- Follow all safety precautions when using a cutting torch.
- If welding, protect all fastener threads from weld spatter.
- For cleaner clearance requirements see chart. P-Type LS (available with C-Tip only) is designed for tighter space configurations.

Clearance Requirements for Installation

	Vertical	Horizontal
P-Type Cleaner	175mm (7")	100mm (4")
P-Type LS Cleaner	138mm (5-1/2")	125mm (5")

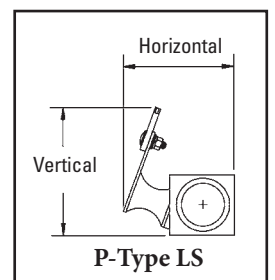
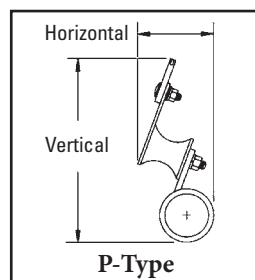

Section 4 – Installation Instructions (cont.)

P-Type Secondary Belt Cleaner

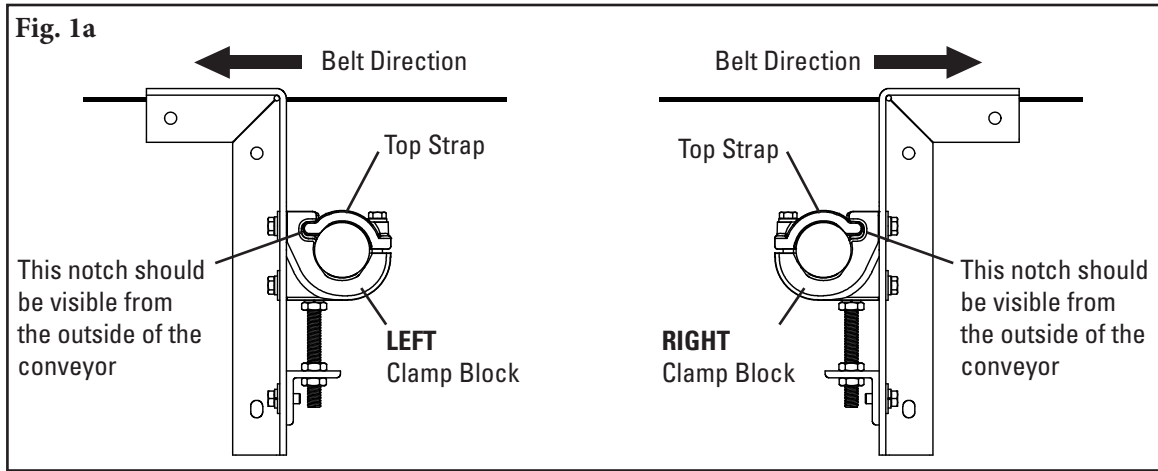

1. Install mounting brackets.

Determine the correct clamp block (left or right) and bracket needed for each side of the conveyor (Fig. 1a). The top strap should be offset away from the belt (you should be able to see the notch for the top strap from the outside of the conveyor).

For chute mounting: For a chute installation a belt location line must first be established. Draw a line on the chute replicating this location. If head pulley and snub pulley are close, it may be necessary to assume an approximate belt line between the two. In the determined location draw a line perpendicular to the belt line. Make a mark on this line 175mm (7") (138mm/5-1/2" for PLS) below belt location line (Fig. 1b).

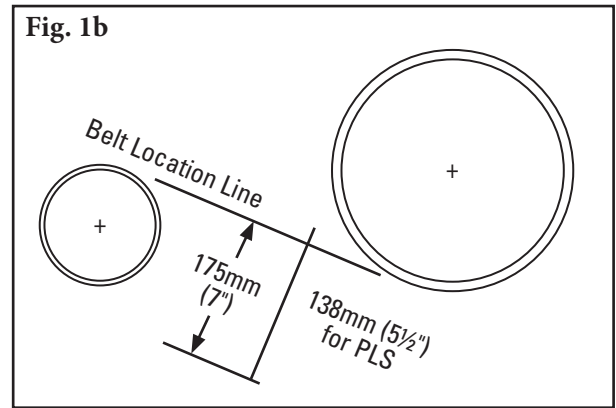

Locate a mounting bracket along the belt location line (Fig. 1b), allowing the centreline of the clamp block to align with the 175mm (7") (138mm/5-1/2" for PLS) mark (Fig. 1c). To move the clamp blocks, if necessary, loosen the clamp block lock bolts and the adjusting bracket lock bolt and move the clamp block to a position where the centre of the hole is 175mm (7") (138mm/5-1/2" for PLS) below the bottom of the belt. Bolt or weld in place. Repeat this step on the opposite side. On one side an access hole may be required (Fig. 1d). **NOTE:** The mounting brackets must be aligned perpendicular to the belt.

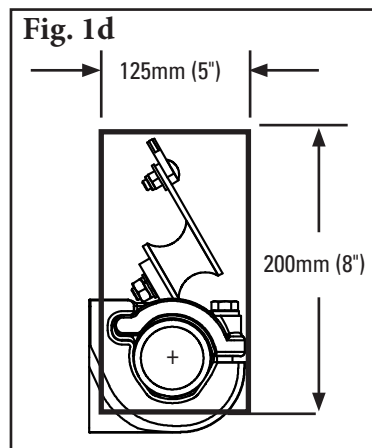
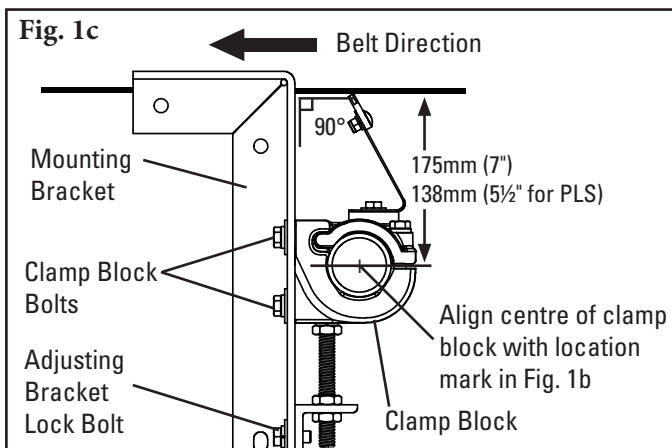

Section 4 – Installation Instructions (cont.)

P-Type Secondary Belt Cleaner

For structure mounting: In most applications the standard mounting brackets will have adequate room to fit on the structure with no cutting. Clamp the mounting bracket into position (use 150mm clamps). Move the clamp block to align the centre of the block with a point 175mm (7") (138mm/5½" for PLS) below the belt (Fig. 1e). To move the clamp blocks, if necessary, loosen the clamp block lock bolts and the adjusting bracket lock bolt and turn the adjusting bolt jam nuts. The bracket can now be bolted or welded in place. Locate and install bracket on the opposite side of belt in alignment with the first bracket. **NOTE:** The brackets must be aligned perpendicular to the belt.

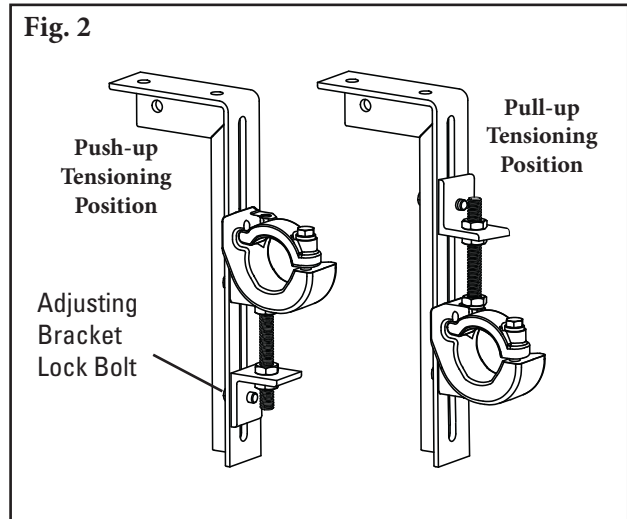
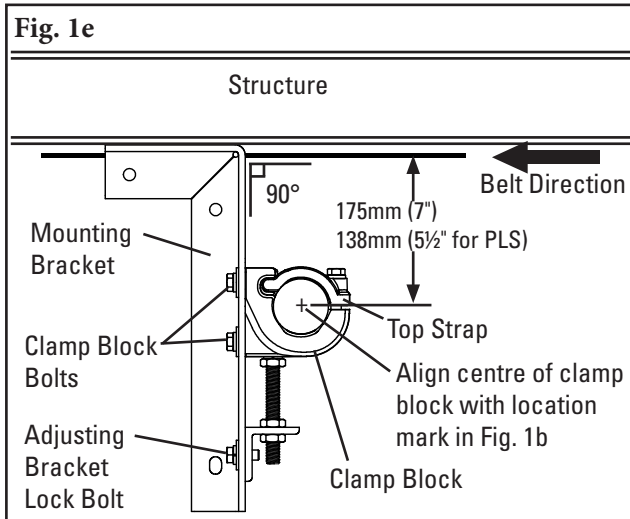

- Choose the tensioner position.** The tensioner is shipped mounted in the push-up position. Depending upon the space constraints of the installation, the tensioner can be optionally mounted in a pull-up position. To do this, loosen the threaded rod lock nut, unscrew the threaded rod and remove adjusting bracket lock bolt. Then move the adjusting bracket and threaded rod to the top of the clamp blocks (Fig. 2) and tighten threaded rod lock nut.
- Install the pole.** Remove the clamp block top strap on the access side of the conveyor, and on the opposite side loosen the clamp block bolt. Slide the pole across and into the loosened clamp block, place near end of pole in bottom section of clamp block (Fig. 3). Replace the top strap on the clamp block, centre the blades on the belt and tighten both clamp block bolts finger tight.
- Set the tip angle.** With angle gauge provided, rotate the tips to the preset angle (Fig. 3) and lock the pole in place by tightening the clamp block bolts equally. **NOTE:** Make sure there is NO tip-to-belt contact while making this alignment. If contact occurs, lower the pole by loosening the clamp block lock bolts and raising the top adjusting bolt jam nut (Fig. 4). When the tips are not touching the belt, repeat this step.

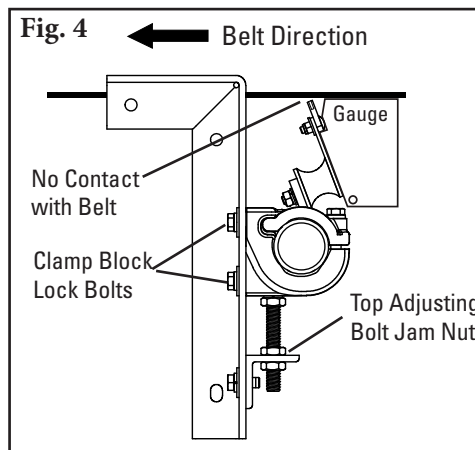
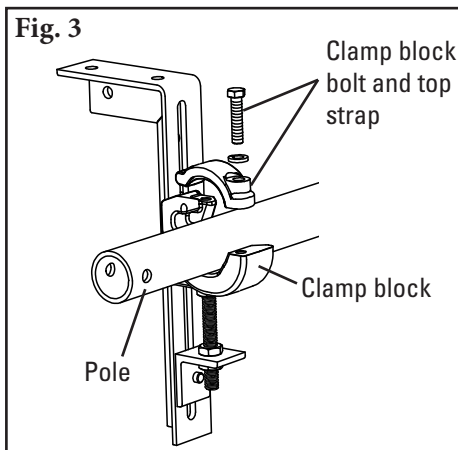

Section 4 – Installation Instructions (cont.)

P-Type Secondary Belt Cleaner

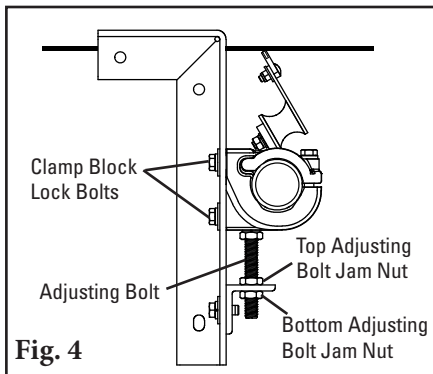

5. **Set the tip tension.** With all clamp block lock bolts slightly loosened, back down the bottom adjusting bolt jam nut 4-5 turns on both sides (Fig. 4). Turn the top adjusting bolt jam nuts down until light contact is made between the tips and belt across the entire width of the cleaner. Give an additional 1 turn to both top adjusting bolt jam nuts and tighten both bottom adjusting bolt jam nuts. Tighten all clamp block lock bolts. Double check that all bolts and nuts on the cleaner are tight.

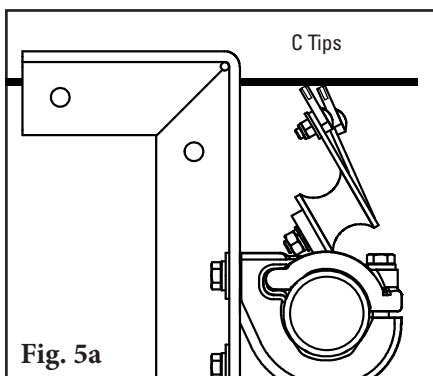

6. **Check the tip tension.** Pull back on the outside tip until the tip-to-belt contact is broken and release. If the cleaner is correctly tensioned the complete blade of the adjacent tip will be visible (Fig. 5a & 5b). If not, add (or reduce) tension by making 1/4 turn adjustments on the adjusting bolt as described in STEP 4 until the adjacent tip is visible.

Test run the cleaner and inspect its performance. If vibration occurs or more cleaning efficiency is desired, increase the tip tension by making a 1/4 turn adjustment on each adjusting bolt.

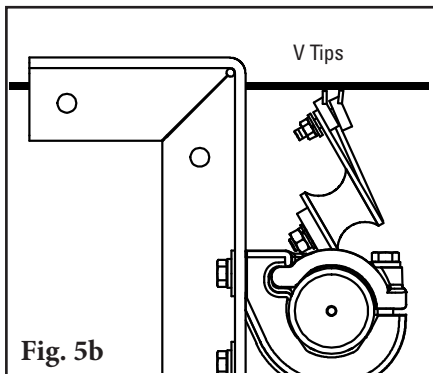

Section 5 – Pre-Operation Checklist and Testing

5.1 Pre-Op Checklist

- Recheck that all fasteners are tightened properly.
- Add pole caps.
- Apply all supplied labels to the cleaner.
- Check the blade location on the belt.
- Be sure that all installation materials and tools have been removed from the belt and the conveyor area.

5.2 Test Run the Conveyor

- Run the conveyor for at least 15 minutes and inspect the cleaning performance.
- Check adjusting brackets and tips for proper tensioning.
- Make adjustments as necessary.

NOTE: Observing the cleaner when it is running and performing properly will help to detect problems or when adjustments are needed later.

Section 6 – Maintenance

Flexco belt cleaners are designed to operate with minimum maintenance. However, to maintain superior performance some service is required. When the cleaner is installed a regular maintenance program should be set up. This program will ensure that the cleaner operates at optimal efficiency and problems can be identified and fixed before the cleaner stops working.

All safety procedures for inspection of equipment (stationary or operating) must be observed. The P-Type® Secondary Belt Cleaner operates at the discharge end of the conveyor and is in direct contact with the moving belt. Only visual observations can be made while the belt is running. Service tasks can be done only with the conveyor stopped and by observing the correct lockout/tagout procedures.

6.1 New Installation Inspection

After the new cleaner has run for a few days a visual inspection should be made to ensure the cleaner is performing properly. Make adjustments as needed.

6.2 Routine Visual Inspection (every 2-4 weeks)

A visual inspection of the cleaner and belt can determine:

- If adjusting brackets are set for optimal tensioning.
- If the belt looks clean or if there are areas that are dirty.
- If the blade is worn out and needs to be replaced.
- If there is damage to the blade or other cleaner components.
- If fugitive material is built up on the cleaner or in the transfer area.
- If there is cover damage to the belt.
- If there is vibration or bouncing of the cleaner on the belt.
- If a snub pulley is used, a check should be made for material buildup on the pulley.
- Significant signs of carryback

If any of the above conditions exist, a determination should be made on when the conveyor can be stopped for cleaner maintenance.

6.3 Routine Physical Inspection (every 6-8 weeks)

When the conveyor is not in operation and properly locked and tagged out a physical inspection of the cleaner to perform the following tasks:

- Clean material buildup off of the cleaner blade and pole.
- Closely inspect the blade for wear and any damage. Replace if needed.
- Ensure full blade to belt contact.
- Inspect the cleaner pole for damage.
- Inspect all fasteners for tightness and wear. Tighten or replace as needed.
- Replace any worn or damaged components.
- Check the tension of the cleaner blade to the belt. Adjust the tension if necessary using the steps on page 8.
- When maintenance tasks are completed, test run the conveyor to ensure the cleaner is performing properly.

Section 6 – Maintenance (cont.)

6.4 Blade Replacement Instructions (C-Tips or V-Tips)

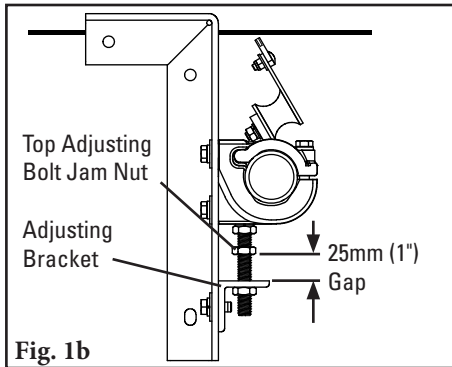

BEFORE YOU BEGIN:

Physically Lock Out And Tag The Conveyor At The Power Source.

1. Release the blade tension and remove worn blade tips.

- a. Loosen the top adjusting bolt jam nuts 25mm (1") on the top of the adjusting brackets (Fig. 1a).
- b. Loosen the clamp block lock bolts on both sides and allow the pole to move down and rest on the raised top adjusting bolt jam nuts (Fig. 1b).
- c. Place location marks across the mounting bracket and the clamp block for quick positioning after blade replacement (Fig. 1c).
- d. Remove the clamp block lock bolts and adjusting bracket lock bolts on each side and remove the pole with the clamp blocks and adjusting brackets attached (Fig. 1d).
- e. Remove the nuts, flat washers and lock washers from the tips and remove worn tips (Fig. 1e).
- f. Insert new blade tips and install flat washers, lock washers and nuts finger tight. Buff the outside corners of the last tip on each side of the cleaner (Fig. 1f).

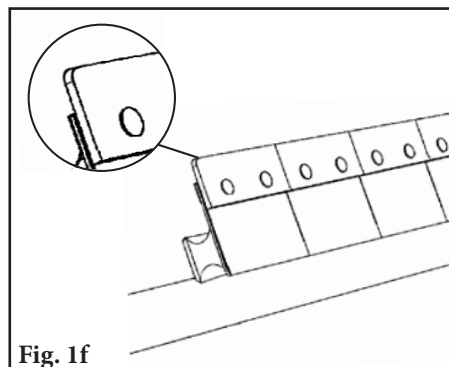
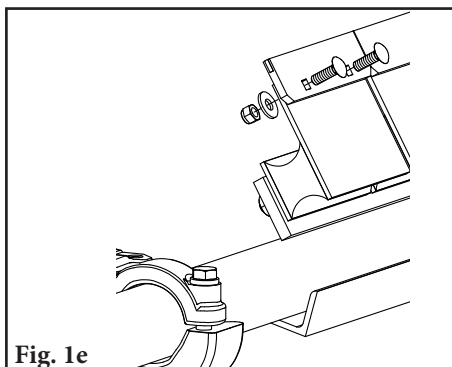
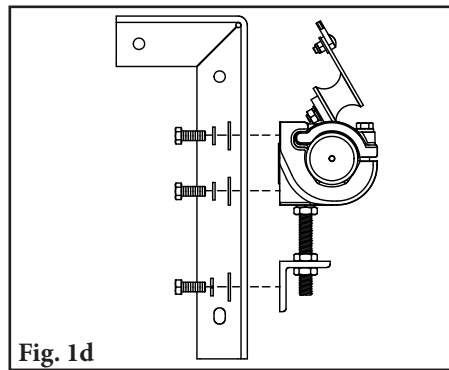
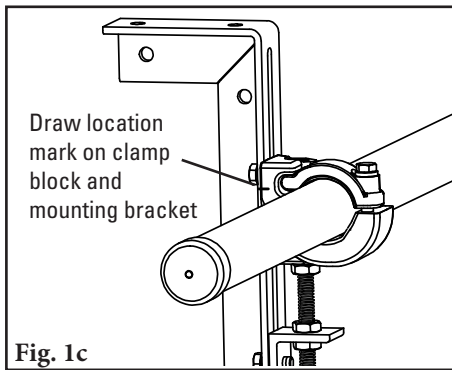
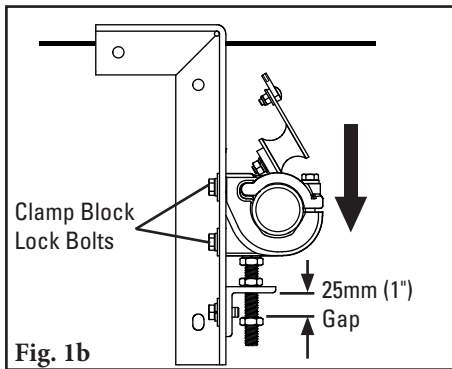

Section 6 – Maintenance (cont.)

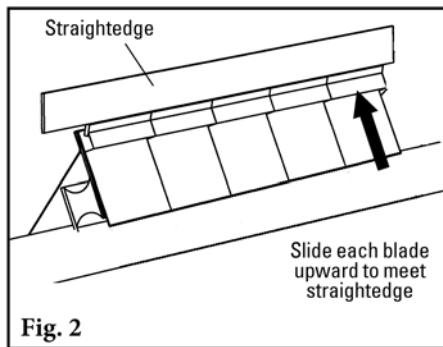

Fig. 2

2. **Align the blade tips.** Push tips together so there is no more than a .25mm to .38mm (.010" to .015") gap between them. Position a straightedge along the top surface of new blade tips. Pull upward on each blade to align with the bottom of the straightedge and tighten the nuts (Fig. 2).

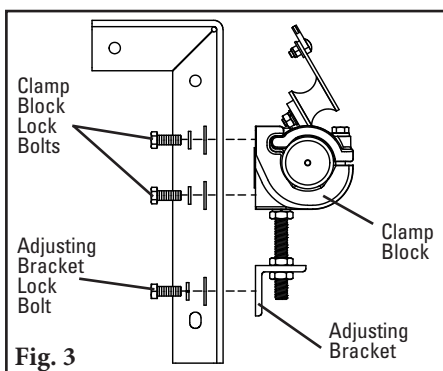

Fig. 3

3. **Reinstall the pole.** Slide the pole back into position on the mounting brackets, aligning marks made on the bracket and the clamp block. Install the two adjusting bracket lock bolts and tighten. Install the four clamp block lock bolts finger tight (Fig. 3).

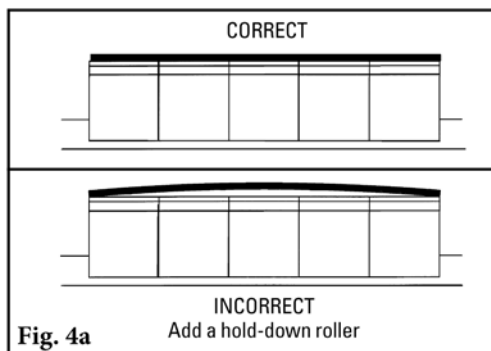

Fig. 4a

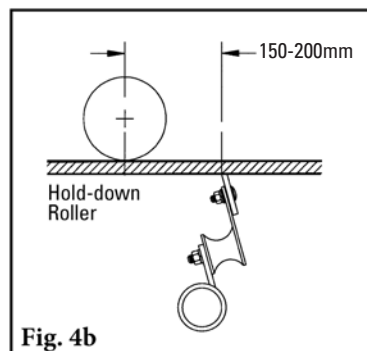

Fig. 4b

4. **Set the blade tension.** Turn the top adjusting bolt jam nuts down until light tip to belt contact is made across the entire width of the cleaner. Add an additional 1 turn on the top adjusting bolt jam nuts and lock the bottom adjusting bolt jam nuts. Tighten all clamp block lock bolts. **NOTE:** If the belt is cupped, do not overtension the blades to contact the belt. A hold-down roller should be installed to flatten the belt (Fig. 4a and 4b). (Try the Stabilizing Return Roller or Stabilizing Roller Bracket Kit.)

5. **Check the blade tip tension.** Pull back on the outer blade in the direction of belt travel until the blade breaks contact with the belt. Let go of the blade. With correct tension the full thickness of the adjacent blade tip should be visible in front of the outer blade (Fig. 5a and 5b). Also check the centre blade in same manner. Add tension in 1/4-turn increments on the top adjusting bolt jam nuts until view of full thickness of the adjacent blade tip is achieved.

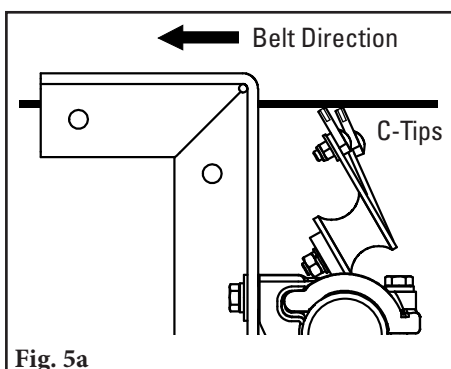

Fig. 5a

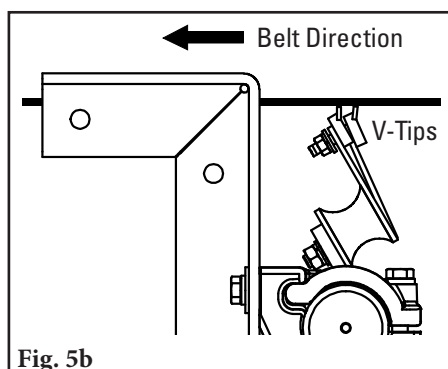

Fig. 5b

6. **Test run cleaner and inspect operation.** If vibration occurs, increase tip tension by making 1/4-turn adjustments.

Section 6 – Maintenance (cont.)

6.5 Maintenance Log

Conveyor Name/No. _____

Date: _____ Work done by: _____ Service Quote #: _____

Activity: _____

Date: _____ Work done by: _____ Service Quote #: _____

Activity: _____

Date: _____ Work done by: _____ Service Quote #: _____

Activity: _____

Date: _____ Work done by: _____ Service Quote #: _____

Activity: _____

Date: _____ Work done by: _____ Service Quote #: _____

Activity: _____

Date: _____ Work done by: _____ Service Quote #: _____

Activity: _____

Date: _____ Work done by: _____ Service Quote #: _____

Activity: _____

Date: _____ Work done by: _____ Service Quote #: _____

Activity: _____

Section 6 – Maintenance (cont.)

6.6 Cleaner Maintenance Checklist

Site: _____ Inspected by: _____ Date: _____

Belt Cleaner: _____ Serial Number: _____

Beltline Information:

Beltline Number: _____ Belt Condition: _____

Belt Width: 450mm (18") 600mm (24") 750mm (30") 900mm (36") 1050mm (42") 1200mm (48") 1350mm (54") 1500mm (60") 1800mm (72")

Head Pulley Diameter (Belt & Lagging): _____ Belt Speed: _____ m/sec Belt Thickness: _____

Belt Splice: _____ Condition of Splice: _____ Number of Splices: _____ Skived Unskived

Material conveyed: _____

Days per week run: _____ Hours per day run: _____

Blade Life:

Date blade installed: _____ Date blade inspected: _____ Estimated blade life: _____

Is blade making complete contact with belt? Yes No

Blade wear: Left _____ Middle _____ Right _____

Blade condition: Good Grooved Smiled Not contacting belt Damaged

Measurement of spring: Required _____ Currently _____

Was Cleaner Adjusted: Yes No

Pole Condition: Good Bent Worn

Lagging: Side Lag Ceramic Rubber Other None

Condition of lagging: Good Bad Other _____

Cleaner's Overall Performance: (Rate the following 1 - 5, 1= very poor - 5 = very good)

Appearance: Comments: _____

Location: Comments: _____

Maintenance: Comments: _____

Performance: Comments: _____

Other comments: _____

Section 7 – Troubleshooting

Problem	Possible Cause	Possible Solutions
Vibration	Cleaner secure bolts not set	Ensure all locking nuts are tight (Loctite)
	Cleaner not set up correctly	Ensure cleaner set up properly (check tip angle with gauge)
	Belt tension too high	Ensure cleaner can conform to belt, or replace with alternate Flexco secondary cleaner
	Belt flap	Introduce hold-down roller to flatten belt
	Cleaner over-tensioned	Ensure cleaner is correctly tensioned
	Cleaner under-tensioned	Ensure cleaner is correctly tensioned
Material buildup on cleaner	Cleaner not set up correctly	Ensure cleaner set up properly (check tip angle with gauge)
	Buildup on chute	Ensure cleaner is not located too close to back of chute, allowing buildup
	Cleaner being overburdened	Introduce Flexco precleaner
	Excessive sticky material	Frequently clean unit of buildup
Damaged belt cover	Cleaner over-tensioned	Ensure cleaner is correctly tensioned
	Cleaner blade damage	Check blade for wear, damage and chips, replace where necessary
	Attack angle not correct	Ensure cleaner set up properly (check tip angle with gauge)
	Material buildup in chute	Frequently clean unit of buildup
Cleaner not conforming to belt	Cleaner not set up correctly	Ensure cleaner set up properly (check tip angle with gauge)
	Belt tension too high	Ensure cleaner can conform to belt, introduce hold-down roller, or replace with alternate Flexco secondary cleaner
	Belt flap	Introduce hold-down roller to flatten belt
	Cleaner cannot conform	Ensure cleaner can conform to belt, introduce hold-down roller, or replace with alternate Flexco secondary cleaner
Material passing cleaner	Cleaner not set up correctly	Ensure cleaner set up properly (check tip angle with gauge)
	Cleaner tension too low	Ensure cleaner is correctly tensioned
	Cleaner blade worn/damaged	Check blade for wear, damage and chips, replace where necessary
	Cleaner being overburdened	Introduce Flexco precleaner
	Belt flap	Introduce hold-down roller to flatten belt
	Belt worn or grooved	Introduce water spray pole
	Cleaner cannot conform	Ensure cleaner can conform to belt, introduce hold-down roller, or replace with alternate Flexco secondary cleaner
Damage to mechanical fastener	Incorrect cleaner blade selection	Change blade type to accommodate fastener style (C-Tip or V-Tip)
	Belt not skived correctly	Spot and redo splice correctly, lowering the profile flush or below belt surface
	Blade angle incorrect	Reset with gauge
Missing material in belt centre only	Cupped Belt	Install hold-down roller and reset blade angle with gauge
	Cleaner blade worn/damaged	Check blade for wear, damage and chips, replace where necessary
Missing material on outer edges only	Cupped Belt	Install hold-down roller and reset blade angle with gauge
	Cleaner blade worn/damaged	Check blade for wear, damage and chips, replace where necessary

Section 8 – Specifications and CAD Drawings

8.1 Specifications and Guidelines

Pole Length Specifications

Cleaner Size		Pole Length		Maximum Conveyor Span	
mm	in.	mm	in.	mm	in.
450	18	1200	48	1075	43
600	24	1350	54	1225	49
750	30	1500	60	1375	55
900	36	1650	66	1525	61
1050	42	1800	72	1675	67
1200	48	1950	78	1825	73
1350	54	2200	88	2075	83
1500	60	2350	94	2225	89
1800	72	2650	106	2525	101

Pole Diameter - 60mm (2-3/8")

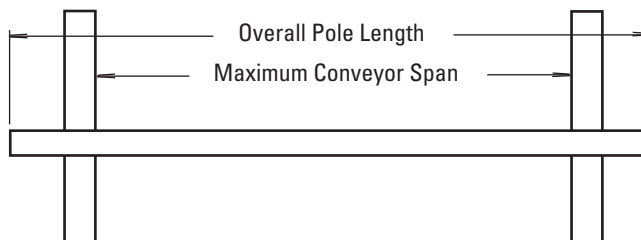

Clearance Guidelines for Installation

Cleaner Type	Belt Width/ Cleaner Size		Horizontal Clearance Required		Vertical Clearance Required	
	mm	in.	mm	in.	mm	in.
P-Type	450 - 1800	18 - 72	100	4	200	8
P-Type LS	450 - 1350	18 - 54	125	5	138	5 1/2

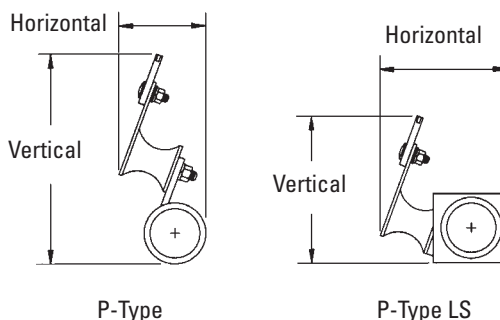

P-Type Cushion Specifications

Cushion	Durometer	Temperature Range
Standard	55A	-35° to 82° C -30° to 180° F
Neoprene	55A	-20° to 110° C -4° to 230° F

Specifications:

- Maximum Belt Speed.....5M/sec (1000 FPM)
- Temperature Rating.....-35°C to 82°C (-30°F to 180°F)
- Usable Blade Wear Length.....9mm (3/8")
- Blade Materials.....C-Tip: Impact Resistant Tungsten Carbide (works with mechanical fasteners)
V-Tip: Long Life Tungsten Carbide (works on vulcanized belts only)
- Available for Belt Widths.....P-Type: 450 to 1800mm (18" to 72")
P-Type LS: 450 to 1350mm (18" to 54")
Other sizes available upon request.
- CEMA Cleaner Rating.....Class 4

Section 8 – Specifications and CAD Drawings (cont.)

8.2 CAD Drawing – P-Type with C-Tips

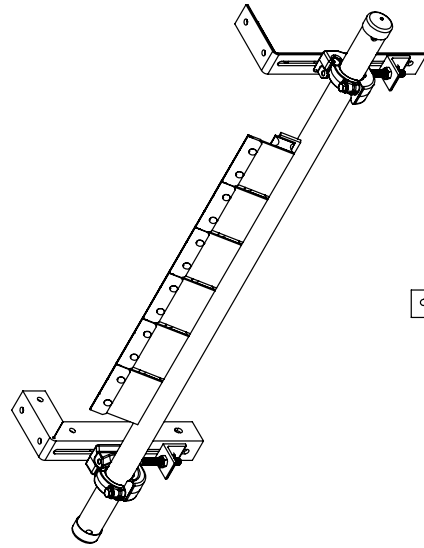

SPECIFICATIONS			P-TYPE CLEANER		
BELT WIDTH 'A' (in)	BELT WIDTH 'A' (mm)	POLE LENGTH 'B' (in)	# OF BLADES	ORDER NUMBER	ITEM CODE
18	450	48	3	PC18	74566
24	600	54	4	PC24	74567
30	750	60	5	PC30	74568
36	900	66	6	PC36	74569
42	1050	72	7	PC42	74570
48	1200	78	8	PC48	74571
54	1350	88	9	PC54	74572
60	1500	94	10	PC60	74573
72	1800	106	12	PC72	74574

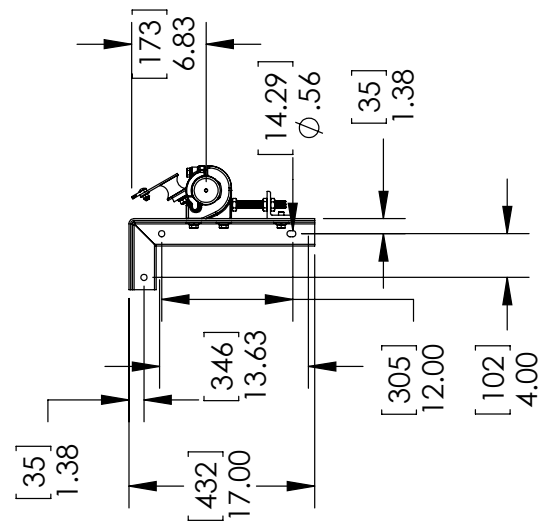
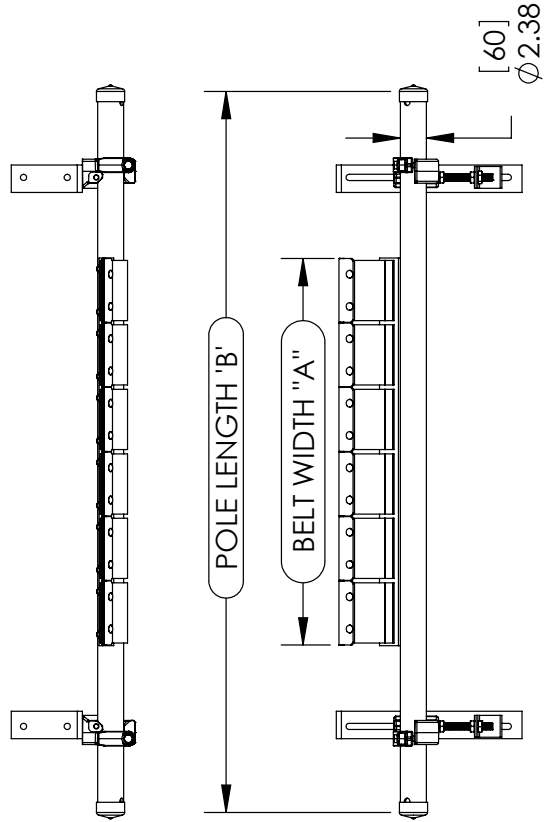

Section 8 – Specifications and CAD Drawings (cont.)

8.3 CAD Drawing – P-Type with V-Tips

SPECIFICATION				PV CLEANER		
BELT WIDTH "A"		POLE LENGTH "B"		# OF BLADES	ORDER NUMBER	ITEM CODE
mm	in	mm	in			
450	18	1250	50	3	PV450	73435
600	24	1350	54	4	PV600	73004
750	30	1500	60	5	PV750	73006
900	36	1650	66	6	PV900	73008
1050	42	1800	72	7	PV1050	73010
1200	48	1950	78	8	PV1200	73012
1400	54	2200	88	9	PV1400	73436
1500	60	2350	94	10	PV1500	73437
1800	72	2650	101	12	PV1800	74598
1950	78	2850	114	13	PV1950	75452
2100	84	2950	118	14	PV2100	74553
2400	96	3250	130	16	PV2400	74555

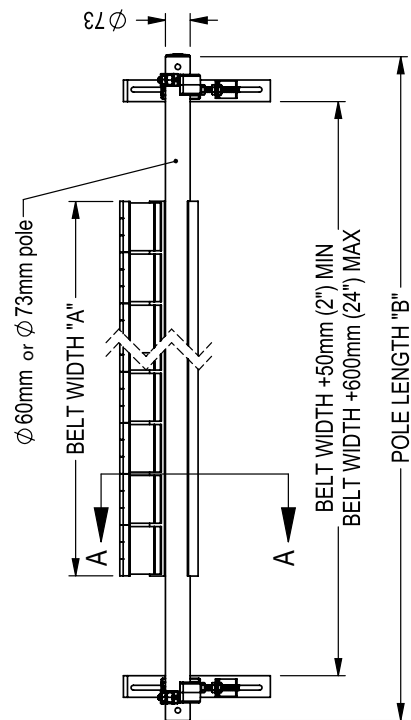
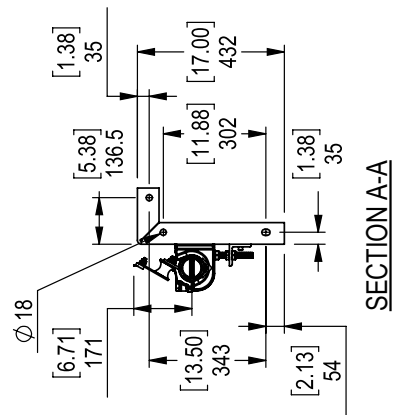
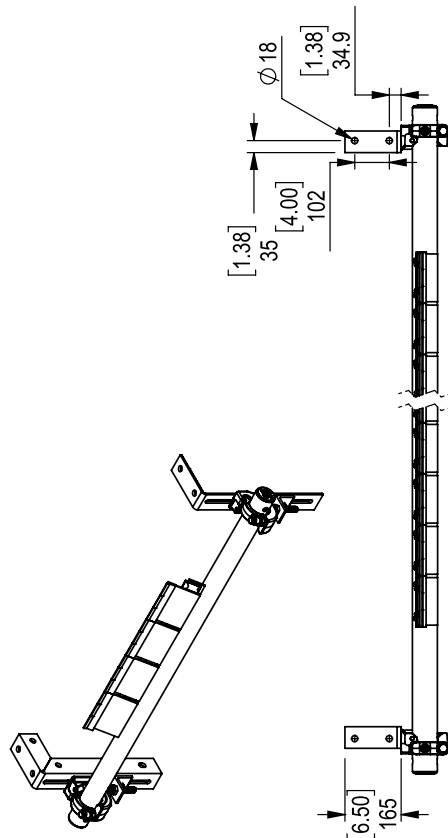

Section 8 – Specifications and CAD Drawings (cont.)

8.3 CAD Drawing – P-Type LS with C-Tips

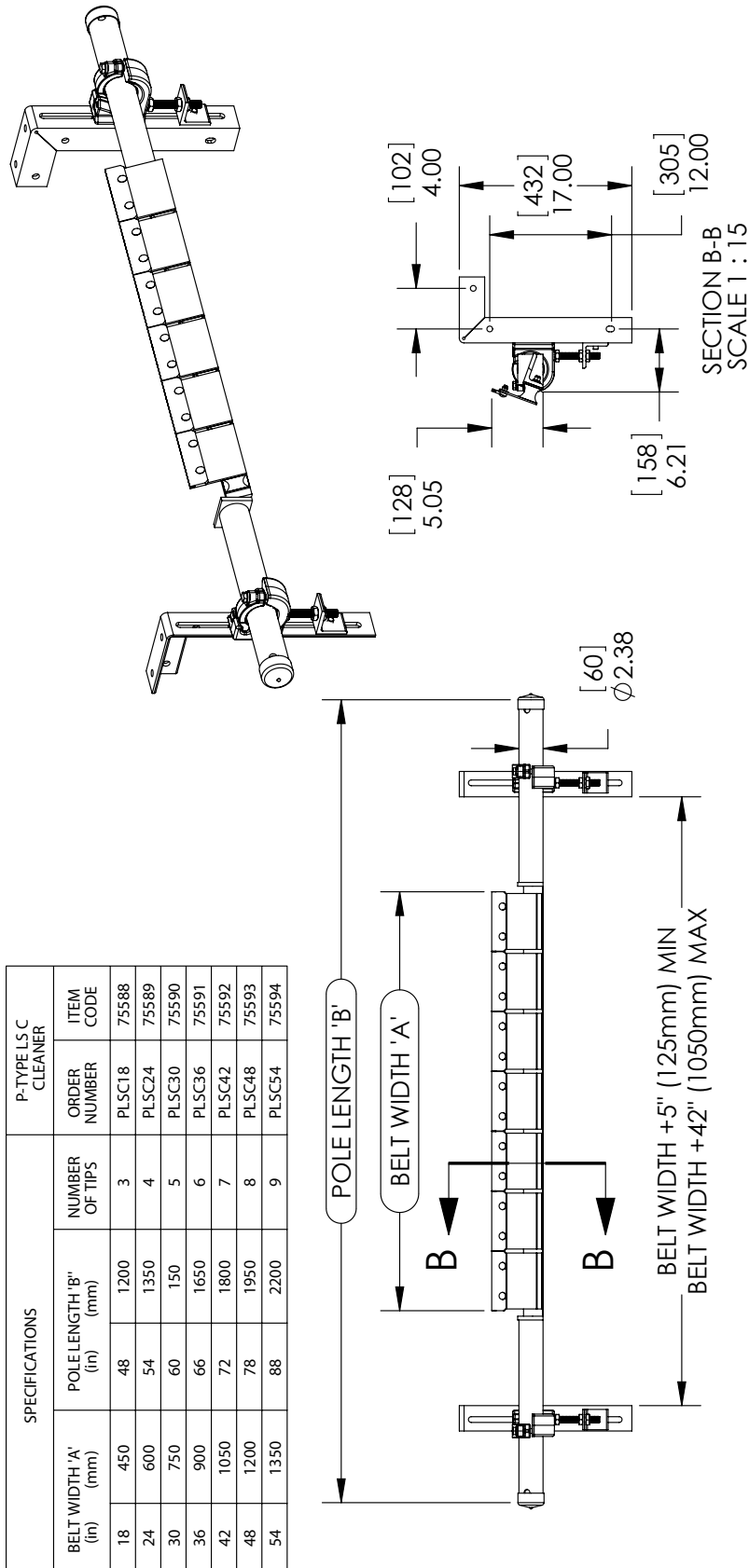

Section 9 – Replacement Parts List

9.1 Replacement Parts List- P-Type Secondary Belt Cleaner

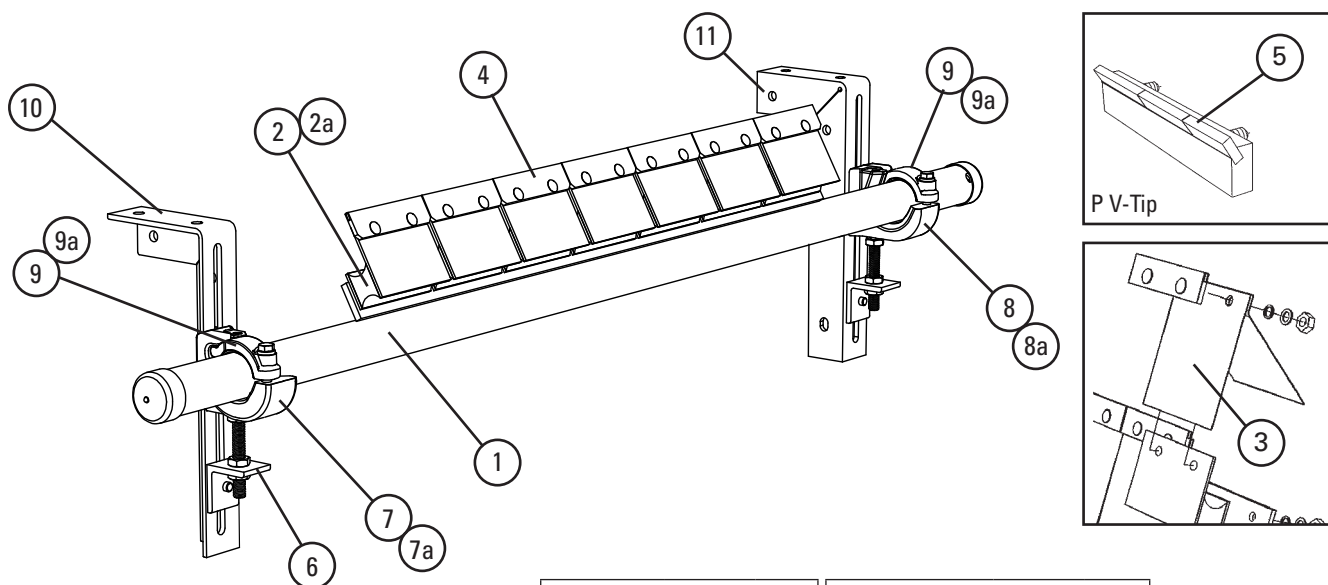

Replacement Parts

REF	DESCRIPTION	POWDER COATED					STAINLESS STEEL			
		BELT WIDTH	POLE LENGTH (MM)	ORDERING NUMBER	ITEM CODE	WT. KG.	ORDERING NUMBER	ITEM CODE	WT. KG.	
1	P-Type® Pole 60 mm Pole Diameter	450	1250	PP450	73003	10.0	PP450-S/S	75382	10.0	
		600	1350	PP600	73005	11.0	PP600-S/S	75383	11.0	
		750	1500	PP750	73007	13.0	PP750-S/S	75384	13.0	
		900	1650	PP900	73009	15.0	PP900-S/S	75385	15.0	
		1050	1800	PP1050	73011	20.0	PP1050-S/S	75386	21.0	
		1200	1950	PP1200	73013	20.0	PP1200-S/S	75387	23.0	
	P-Type Pole 73 mm Pole Diameter	1400	2200	PP1400	73015	24.0	PP1400-S/S	75388	25.0	
		1500	2350	PP1500	73016	25.0	PP1500-S/S	75389	26.0	
		1800	2650	PPHD1800	74597	27.0	PPHD1800-S/S	A1781	28.0	
		2000	2850	PPHD2000	74556	31.0	PPHD2000-S/S	A2120	29.0	
		2100	2950	PPHD2100	A2803	38.0	PPHD2100-S/S	A1613	39.0	
		2400	3250	PPHD2400	74557	44.0	PPHD2400-S/S	A1775	45.0	
2	P Cushion			PHA	73626	1.0	PHSC-S/S	73433	1.0	
2a	P-Type Powerflex Cushion						PFC-P-S/S	79289	1.9	
3	P Polyshield			PPS6	73024	1.0		PSSS	74773	1.0
-	PU-Tip (Polyurethane Tip for Fastened Belts)			PU150	73020	1.0				
4	C-Tip (for mechanically spliced and vulcanised belts)			CT6	74535	0.4				
5	P V-Tip* (for vulcanised belts only)			PSA150	73156	0.4	PVT6-S/S	75420	0.4	
6	Adjusting Bracket Kit* (1ea.)			PAB	75513	0.7	PAB-S/S	75515	0.7	
7	Pole Clamp Kit Left* (1ea.) (incl. item 9) (for sizes 450-1200mm)			CCKL	79224	3.1	CCKL-S/S	79226	3.1	
8	Pole Clamp Kit Right* (1ea.) (incl. item 9) (for sizes 450-1200mm)			CCKR	79228	3.1	CCKR-S/S	79230	3.1	
9	Cradle Clamp Top Strap (1ea.) (for use on L or R Pole Clamp Kit)			CCKTS	79232	0.5	CCKTS-S/S	79234	0.5	
10	Mounting Bracket Kit Left			PMBL (left)	75516	3.8	PMBL-S/S (left)	75518	3.8	
11	Mounting Bracket Kit Right			PMBL (right)	75519	3.8	PMBL-S/S (right)	75521	3.8	
-	Cradle Clamp Mounting Kit* (for sizes 450-1200mm) (incl. 2 ea. item 6, and 1 ea. Items 7, 8, 10 & 11)			CCMK	78919	15.0	CCMK-S/S	78921	15.0	
HEAVY-DUTY COMPONENTS										
7a	HD Pole Clamp Kit Left* (1ea.) (incl. item 9a) (for sizes 1200-2400mm)			CCKHDL	79225	4.0	CCKHDL-S/S	79227	4.0	
8a	HD Pole Clamp Kit Right* (1ea.) (incl. item 9a) (for sizes 1200-2400mm)			CCKHDR	79229	4.0	CCKHDR-S/S	79231	4.0	
9a	HD Cradle Clamp Top Strap (1ea.) (for use on L or R HD Pole Clamp Kit)			CCKHDTS	79233	0.8	CCKHDTS-S/S	73235	0.8	
-	HD Cradle Clamp Mounting Kit* (for sizes 1200-2400mm) (incl. 2 ea. item 6, and 1 ea. Items 7, 8, 10 & 11)			CCMKHD	78920	16.7	CCMKHD-S/S	78922	16.7	

*Hardware included

Section 10 – Other Flexco Conveyor Products

Flexco provides many conveyor products that help your conveyors to run more efficiently and safely. These components solve typical conveyor problems and improve productivity.

Here is a quick overview on just a few of them:

EZP1 Precleaner



- Patented ConShear™ blade renews its cleaning edge as it wears
- Visual Tension Check™ for optimal blade tensioning and simple retensioning
- Quick and easy one-pin blade replacement Material Path Option™ for optimal cleaning and reduced maintenance

Flexco Slider/Impact Beds



- Adjusting troughing angles for easy installation and adjustability
- Long-wearing UHMW for sealing the load zone
- Offered in both Light & Medium duty designs to affordably fit your application

MHS Secondary Cleaner with Service Advantage Cartridge



- An easy slide-out cartridge for service
- Cartridge design to speed up blade-change maintenance
- Patented PowerFlex™ Cushions for superior cleaning performance
- Compatible with Flexco mechanical splices

PT Max™ Belt Trainer



- Patented “pivot & tilt” design for superior training action
- Dual sensor rollers on each side to minimise belt damage
- Pivot point guaranteed not to freeze up
- Available for topside and return side belts

Flexco Specialty Belt Cleaners



- “Limited space” cleaners for tight conveyor applications
- High Temp cleaners for severe, high heat applications
- A rubber-fingered cleaner for chevron and raised rib belts
- Multiple cleaner styles in stainless steel for corrosive applications

Belt Ploughs



- A belt cleaner for the tail pulley
- Exclusive blade design quickly spirals debris off the belt
- Economical and easy to service
- Available in vee or diagonal models

The Flexco Vision

To become the leader in maximising
belt conveyor productivity for our customers worldwide
through superior service and innovation.

Flexco (Aust.) Pty. Ltd • 10 Solent Circuit, Norwest • NSW, Australia, 2153 • Australia
Tel: 612-8818-2000 • Fax: 612-8824-6333 • E-mail: salesau@flexco.com

Visit www.flexco.com for other Flexco locations and products.

©2020 Flexible Steel Lacing Company. 02/19/20. For reorder: X2859

