

Hustler Two Bag Catcher Owner's Manual



HUSTLER®
TURF EQUIPMENT

.....

P.O. Box 7000

...

Hesston, Kansas

•

67062-2097

TABLE OF CONTENTS

1. General Information	Sect. 1
2. Safety Precautions	Sect. 2
3. Assembly Instructions	Sect. 3
4. Operation	Sect. 4
5. Maintenance	Sect. 5
6. Storage	Sect. 6
7. Parts List	Sect. 7

GENERAL INFORMATION

This manual applies to the following equipment:

FasTrak Super Duty 36/42 Two Bag Catcher, number 928986

FasTrak Super Duty 48/54/60 & FasTrak 48/54 Two Bag Catcher, number 928960

FasTrak 44/52 Two Bag Catcher, number 928408

FasTrak 44 Adapter Kit, number 109516

FasTrak Super Duty 48 & FasTrak 48 Adapter Kit, number 109836

FasTrak 52 Adapter Kit, number 109517

FasTrak Super Duty 54 & FasTrak 54 Adapter Kit, number 109835

FasTrak Super Duty 60 Adapter Kit, number 109994

To the new owner

The purpose of this manual is to assist owners and operators in maintaining and operating the Hustler Two Bag Catcher. Please read it carefully; information and instructions furnished can help you achieve years of dependable performance.

Using this manual

General operation, adjustment and maintenance guidance is outlined for both the experienced and novice Hustler user. Operating conditions vary considerably and cannot all be addressed individually. Through experience, however, operators should find no difficulty in developing good operating skills suitable to most conditions.

Directions used in this manual, for example RIGHT or LEFT, refer to directions when seated on tractor facing forward, unless otherwise stated.

Photographs and illustrations used were current at the time of printing, but subsequent production changes may cause

your machine to vary slightly in detail. Hustler Turf Equipment reserves the right to redesign and change the machine as deemed necessary, without notification. If a change has been made to your machine which is not reflected in this owner's manual, or the parts manual, see your Hustler dealer for current information and parts.

Warranty registration

The Delivery and Warranty Registration form must be completed and signed to validate your warranty protection. As the new equipment owner, you are expected to see that the card is completed and forwarded to Hustler Turf Equipment at time of delivery.

Be sure to register the tractor plus each attachment that displays a model and serial identification number plate with Hustler Turf Equipment.

IMPORTANT: Any unauthorized modification, alteration, or use of non-approved attachments voids the warranty and releases Hustler Turf Equipment from any liability arising from subsequent use of this equipment.

Parts and service

Use original Hustler replacement parts only. These parts are available through your local Hustler dealer. To obtain prompt, efficient service, always provide the following information when ordering parts:

1. Correct part description and number, as given in the parts manual supplied with your owner's packet.

2. Correct model number.

All warranty repair and service must be handled through an authorized Hustler dealer. Arrangements should be made through your local service center.

SAFETY PRECAUTIONS



This safety alert symbol is used to call attention to a message intended to provide a reasonable degree of **PERSONAL SAFETY** for operators and other persons during the normal operation and servicing of this equipment.

DANGER – Denotes immediate hazards which **WILL** result in severe personal injury or death.

WARNING – denotes a potential hazard or unsafe practice which **COULD** result in severe personal injury or death.

All operators should read this manual and be instructed about safe operating and maintenance procedures. This is the owner's responsibility.

Incorrect usage of this machine may result in severe injury. It is the owner's responsibility that all operators read this manual thoroughly and be properly trained in

operation and maintenance before attempting to set-up, adjust, or service this machine. This owner's manual contains many safety precautions that must be followed to avoid injury.

- ▲ Always stop tractor engine, place steering control lever in the park brake position and remove ignition key when leaving operator's seat.
- ▲ Always be aware of any obstructions, especially small children, when backing or unloading the bags.
- ▲ Always keep safety shields and covers in place while operating machine.
- ▲ Never work on blower assembly or mower deck when the tractor engine is running.
- ▲ Never operate machine with bagger lid in the raised position except for unloading.
- ▲ Never attempt high speed maneuvering in crowded or congested areas.
- ▲ Always operate with complete catcher system or side discharge chute in place.

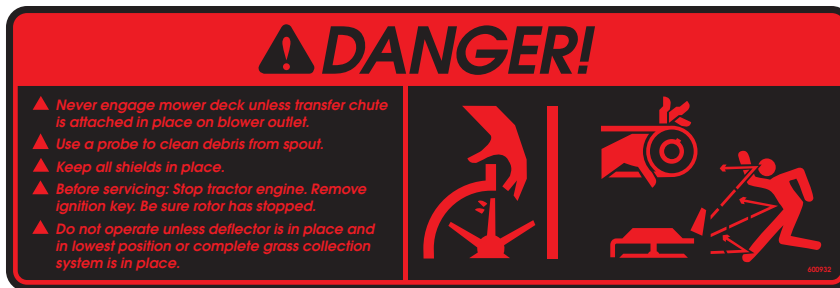

Never engage mower deck unless transfer chute is attached in place on blower outlet.
Use a probe to clean debris from spout.
Keep all shields in place.
Before servicing: Stop tractor engine, remove ignition key and engage park brake. Be sure rotor has stopped.
Never operate unless deflector is in place and in lowest position or complete grass collection system is in place.

ASSEMBLY INSTRUCTIONS

These instructions apply to the assembly of the Hustler Two Bag Catcher to a FasTrak 44/52/48/54 tractor or a FasTrak Super Duty 36/42/48/54/60 tractor.

It is intended that these units be installed by trained Hustler service personnel. If additional assistance is required, contact the Hustler Customer Service Department.

Directions given in these instructions, for example left and right, refer to direction while seated on the tractor.

Before proceeding, read thru the following instructions to familiarize yourself, while at the same time identify and inventory kit parts supplied.

Unpack and inspect all parts. Notify carrier of any shipping damages immediately.

Parts list - 928986

Part No.	Description	Qty.
108730	Frame assembly	1
108194	Blower assembly	1
601228	Transfer tube - upper	1
601229	Transfer tube - lower	1
056077	CS .250-20 x 1.00 HX G5	2
068551	NT .250-20HXZY NL	2
601236	Bag	2
108733	Hood w/a	1
601223	Latch pin	1
024927	NT .250-20 HX GR5 ZN	2
768515	FW .281 x .625 x .050/.080 HD	2
109097	Mount w/a RH	1
109098	Mount w/a. LH	1
109099	Support tube w/a	1
109089	Rear engine guard	1
108488	Weight	1
108489	Weight	1
016444	CS .375-16 x 3.00 HX G5 ZN	2
054502	NT .375-16 HX G5 ZN	9
767954	FW .406x.812x.06 SAE HRD ZN	20
080655	CS .375-16 x 1.50 HX G5 ZN	6
056036	CS .375-16 x 2.25 HX	5
016428	CS .375-16 x 2.50 HX	2
109101	Baffle	1
108022	Belt cover	1
601233	Belt	1
783738	CS .625-11 x 3.00 Full HX G5 ZN	1
601237	Knob	2
601225	Drive pulley	1
601640	Bungee strap	1

Parts list - 928960

Part No.	Description	Qty.
108730	Frame assembly	1
108733	Hood w/a	1
601228	Transfer tube - upper	1
601229	Transfer tube - lower	1
108194	Blower assembly	1

601236	Bag	2
768515	FW .281 x .625 x .050/.080 HD	2
068551	NT .250-20HXZY NL	2
056077	CS .250-20 x 1.00 HX G5	2
767954	FW .406x.812x.06 SAE HRD ZN	26
054502	NT .375-16 HX G5 ZN	8
378760	Exhaust extension	1
769299	Screw	1
108220	Catcher brace	1
108219	Catcher brace	1
104489	Weight	1
767962	FW .531x1.063x.09 SAE HRD ZN	4
008193	NT .500-13 HX G5 ZN	2
016428	CS .375-16 x 2.50 HX	2
108171	Frame mount tube	1
109641	Mount bracket	1
109612	Bumper support	1
068023	CS .500-13 x 3.75 HX GR8 ZN	2
023317	NT .500-13 UNT LK G5 ZN	2
601640	Bungee strap	1
108818	Heat shield	1
056036	CS .375-16 x 2.250 HX G5 ZN	4
712976	FW .531 x 1.375 x .125 ZN	4
107924	Catcher brace base	2
080655	CS .375-18 x 1.500 HX G5 ZN	6
036236	CS .312-18 x 1.00 HX G5 ZN	2
789214	Weight	1
042630	CS .500-13 x 6.50 HX GR5 ZN	2

Parts list - 928408

Part No.	Description	Qty.
108730	Frame assembly	1
108194	Blower assembly	1
601228	Transfer tube - upper	1
601229	Transfer tube - lower	1
601640	Bungee strap	1
056077	CS .250-20 x 1.00 HX G5	2
068551	NT .250-20HXZY NL	2
601236	Bag	2
108733	Hood w/a	1
034272	NT .312-18 HX G5 ZN	2
601223	Latch pin	1
025403	FW .281 x .625 x .062 ZN	4
024927	NT .250-20 HX G5 ZN	2
768515	FW .281 x .625 x .050/.080 HD	2

Deck adapter kits

When mounting the Two Bag Catcher on a FasTrak with a 44" deck, an adapter kit, p/n 109516, must be used. The following parts are included with this kit.

Part No.	Description	Qty.
767954	FW .406x.812x.06 SAE HRD ZN	12
054502	NT .375-16 HX G5 ZN	6
378760	Exhaust extension	1

769299	Screw	1
601226	Drive pulley	1
104489	Weight	5
783738	CS .625-11 x 3.00 Full HX G5 ZN	1
767962	FW .531x1.063x.09 SAE HRD ZN	8
008193	NT .500-13 HX G5 ZN	4
016568	CS .500-13 x 3.00 HX ZN	4
016428	CS .375-16 x 2.50 HX	2
108171	Frame mount tube	1
108222	Mount bracket	1
109265	Baffle	1
056036	CS .375-16 x 2.25 HX	2
109598	Belt cover	1
601659	Belt	1
109468	Rear engine guard	1
109470	Brace, RH	1
109469	Brace, LH	1
109471	Extension bracket	1
036244	CS .375-16 x 1.00 HX G5 ZN	4
109522	Deck stop plate	1
052837	CS .312-18 x 1.50 HX G5 ZN	1
768523	FW .343 x .687 x .051/.080	1
034272	NT .312-18 HX G5 ZN	1

When mounting the Two Bag Catcher on a FasTrak with a 52" deck, an adapter kit, p/n 109517, must be used. The following parts are included with this kit.

Part No.	Description	Qty.
767954	FW .406x.812x.06 SAE HRD ZN	12
054502	NT .375-16 HX G5 ZN	6
109468	Engine guard	1
378760	Exhaust extension	1
769299	Screw	1
109469	Catcher brace LH	1
109470	Catcher brace RH	4
036244	CS .375-16 x 1.00 HX G5 ZN	4
601227	Drive pulley	1
104489	Weight	5
783738	CS .625-11 x 3.00 Full HX G5 ZN	1
767962	FW .531x1.063x.09 SAE HRD ZN	8
008193	NT .500-13 HX G5 ZN	4
016568	CS .500-13 x 3.00 HX ZN	4
016428	CS .375-16 x 2.50 HX	2
108222	Mount bracket	1
768523	FW .343x.687x.051HD ZN/YL	1
056036	CS .375-16 x 2.25 HX	2
109521	Belt cover	1
601231	Belt	1
034272	NT .312-18 HX G5 ZN	1
109522	Deck stop plate	1
109268	Blower baffle	1
108171	Frame mount tube	1
109471	Extension bracket	1
052837	CS .312-18 x 1.50 HX G5 ZN	1

When mounting the Two Bag Catcher on a Mini Z with a 52" deck, an adapter kit, p/n 109519, must be used. The following parts are included with this kit.

Part No.	Description	Qty.
767954	FW .406x.812x.06 SAE HRD ZN	12
054502	NT .375-16 HX G5 ZN	6
109602	Engine guard	1
378760	Exhaust extension	1
109473	Catcher brace LH	1
109603	Catcher brace RH	4
036244	CS .375-16 x 1.00 HX G5 ZN	2
601227	Drive pulley	1
104497	Weight	1
783738	CS .625-11 x 3.00 Full HX G5 ZN	1
016428	CS .375-16 x 2.50 HX	2
108222	Mount bracket	1
768523	FW .343x.687x.051HD ZN/YL	5
056036	CS .375-16 x 2.25 HX	2
109521	Belt cover	1
034272	NT .312-18 HX G5 ZN	3
109268	Blower baffle	1
108171	Frame mount tube	1
109475	Extension bracket	2
052837	CS .312-18 x 1.50 HX G5 ZN	1
036236	CS .312-18 x 1.00 HX G5 ZN	6
788919	Tailpipe extension	1
601231	Belt	1

When mounting the Two Bag Catcher on a FasTrak 48 or FasTrak Super Duty 48 deck, an adapter kit, p/n 109836, must be used. The following parts are included with this kit.

Part No.	Description	Qty.
601226	Drive pulley	1
783738	CS .625-11 x 3.00 Full HX G5 ZN	1
108718	Belt cover	1
601231	Belt	1
109102	Blower baffle	1
025403	FW .281x.625x.062 ZN	2
024927	NT .250-20 HX G5 ZN	2

When mounting the Two Bag Catcher on a FasTrak Super Duty 60" deck, an adapter kit, p/n 109994, must be used. The following parts are included with this kit.

Part No.	Description	Qty.
601227	Drive pulley	1
783738	CS .625-11 x 3.00 Full HX G5 ZN	1
109995	Belt cover	1
601667	Belt	1
109998	Blower baffle	1
025403	FW .281x.625x.062 ZN	2
024927	NT .250-20 HX G5 ZN	2

When mounting the Two Bag Catcher on a FasTrak 54" or FasTrak Super Duty 54" deck, an adapter kit, p/n 109835, must be used. The following parts are included with this kit.

Part No.	Description	Qty.
601227	Drive pulley	1
783738	CS .625-11 x 3.00 Full HX G5 ZN	1
108718	Belt cover	1

601232	Belt	1
109103	Blower baffle	1
025403	FW .281x.625x.062 ZN	2
024927	NT .250-20 HX G5 ZN	2

Mower deck preparation

NOTE: Refer to illustrated parts listings when assembling the unit.

1. Park the tractor on a flat surface. Place the steering control levers in the park brake position and shut off the ignition switch and remove the key from the switch. Disconnect the negative battery cable.
2. Remove the right side pulley cover, discharge chute and discharge chute bracket.
NOTE: Retain these parts as they will be re-installed when the Catcher is removed.
3. Remove the existing spindle bolt and place the existing cup washer between the head of the new bolt and the drive pulley. Torque the bolt into the pulley before threading the bolt into the spindle shaft. Torque top spindle bolt to 118 ft.-lbs.
Thread the pulley, cup washer and bolt assembly into the right hand spindle shaft. Torque bolt to 118 ft.-lbs. Fig. 3-1
4. Attach the baffle, supplied with the correct adapter kit, to the underneath side of the blower assembly per Fig. 3-2.
5. Attach the blower assembly to the deck using the hardware shown per Fig. 3-3. **NOTE:** Adjust the blower housing until the deck opening is sealed against the blower housing. Tighten the bolts.
6. Install and route the blower belt, supplied with the correct adapter kit, to the deck per Fig. 3-4. Tension the belt, using the belt tension bolt until the the tension spring is compressed to a length of 3" + .25 / - .00".

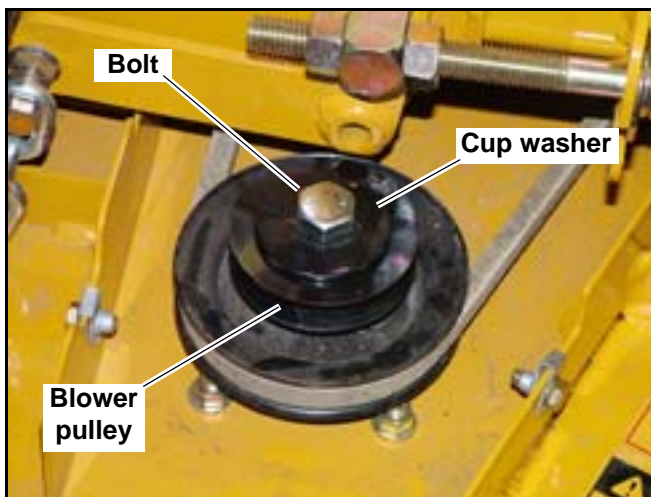

Figure 3-1

7. Attach the belt cover to the blower housing studs. Fig. 3-5
44/52 decks only: Remove the bolt and nut shown in Fig. 3-6 and replace it with the hardware shown. Lock the belt cover in place using the new hardware.

44/52 decks only: Attach the deck stop plate to the belt cover. Adjust it using the holes shown for the proper deck.



WARNING: Do not operate deck without discharge chute or complete catcher system in place.



Figure 3-2

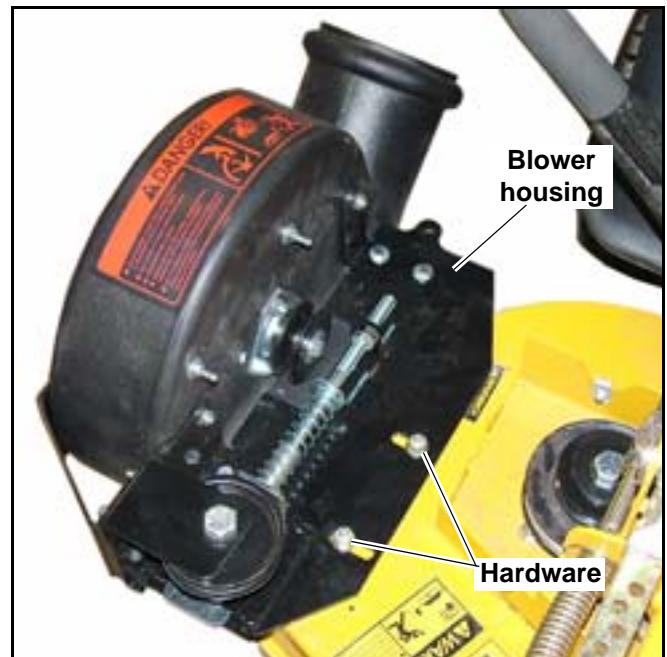

Figure 3-3

Tractor Preparation - FasTrak 48/54

NOTE: Refer to illustrated parts listings when assembling the unit.



WARNING: Allow engine and muffler to cool before assembling the unit to the tractor.

1. Attach heat shield to the frame mount tube. Fig. 3-7
2. Attach the frame mount tube to the rear engine guard. Fig. 3-7

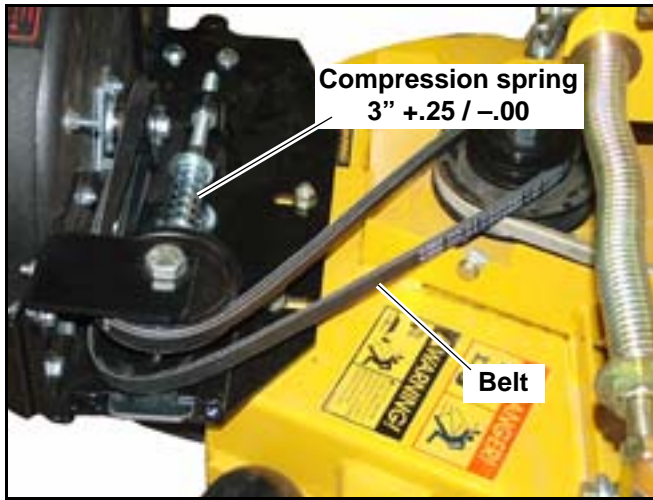

Figure 3-4

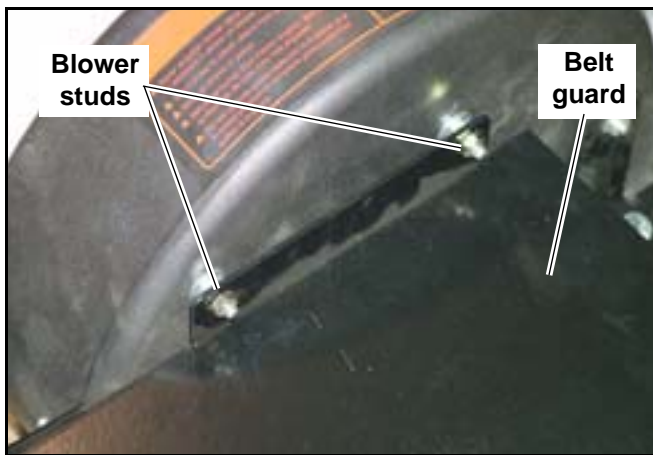

Figure 3-5

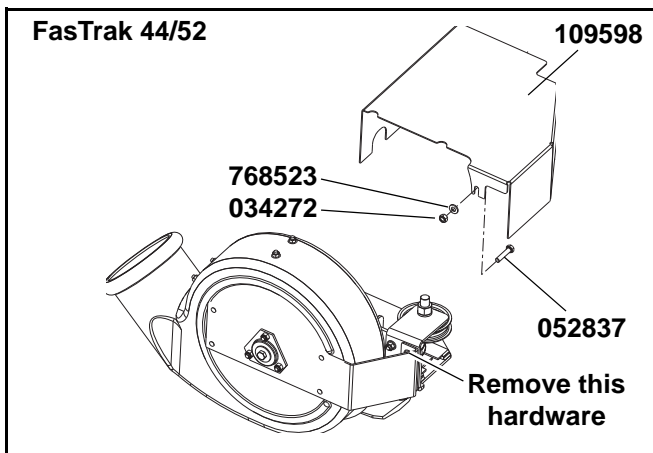

Figure 3-6

3. Attach the mounting bracket to the frame mount tube. Fig. 3-7
4. Attach the two catcher braces to the frame mount tube. Fig. 3-8
5. Remove the two lower bolts on each of the stabilizer wheels and attach the two catcher brace bases using the hardware shown. Fig. 3-9 & Fig. 3-10
6. Attach the lower part of the two catcher braces to the two catcher brace bases. Fig. 3-10

7. Slide the catcher hood assembly onto the frame mount tube. Fig. 3-11
8. Slide the exhaust extension onto the muffler exhaust tube. Rotate the extension so the hole is located on bottom and drill a 5/32" dia. hole in the muffler tailpipe. Attach the exhaust extension using the screw per Fig. 3-12.
9. Remove the operator's foot rest from the tractor. Bolt the weights to each other and then attach them to the tractor per Fig. 3-13. Re-attach the operator's foot rest to the tractor.
10. Place the bags in the catcher assembly, making sure that the non-mesh side of the bag is towards the operator, close the hood and insert the pin. Fig. 3-14 & Fig. 3-15

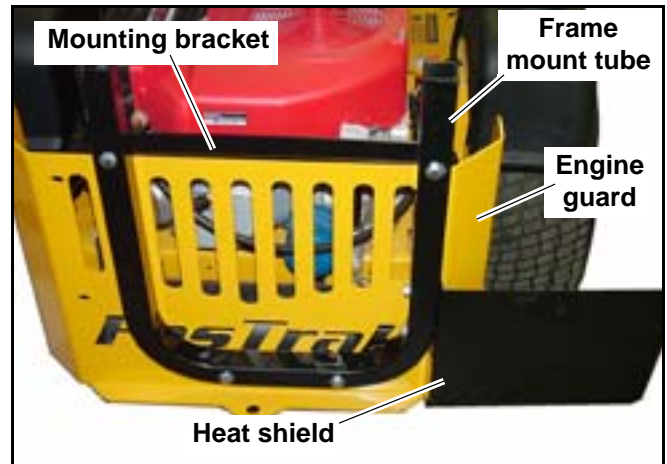

Figure 3-7

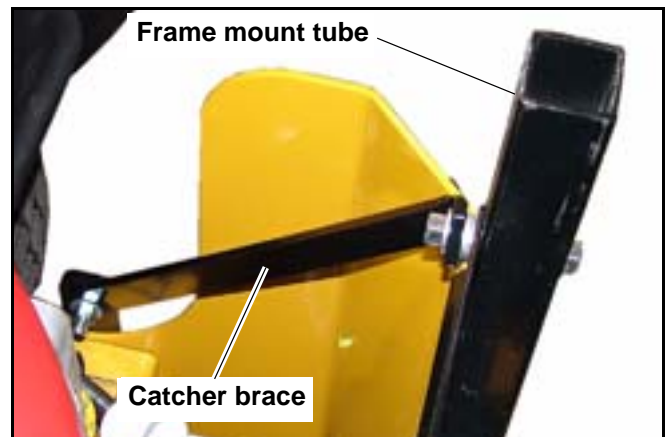

Figure 3-8

Tractor preparation - Mini Z 36/42 & FasTrak Super Duty 36/42

NOTE: Refer to illustrated parts listings when assembling the unit.



WARNING: Allow engine and muffler to cool before assembling the unit to the tractor.

1. Park the tractor on a flat surface, place steering control levers in the park brake position, shut-off engine and

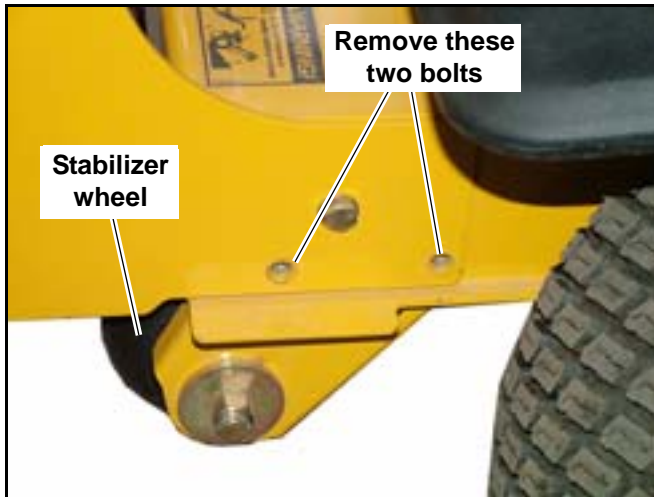

Figure 3-9

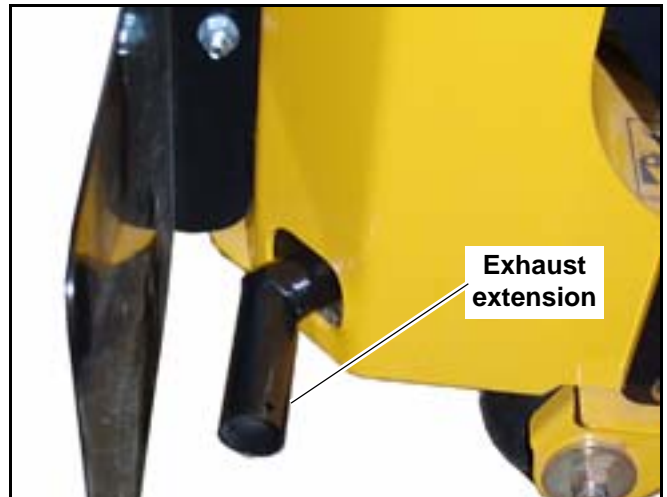

Figure 3-12

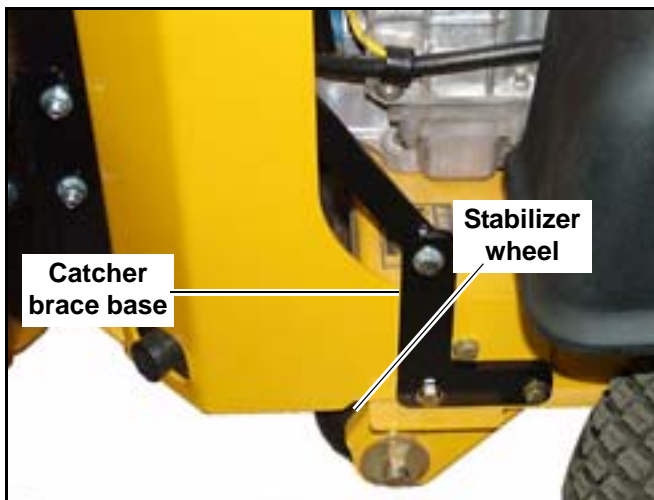

Figure 3-10



Figure 3-13



Figure 3-11

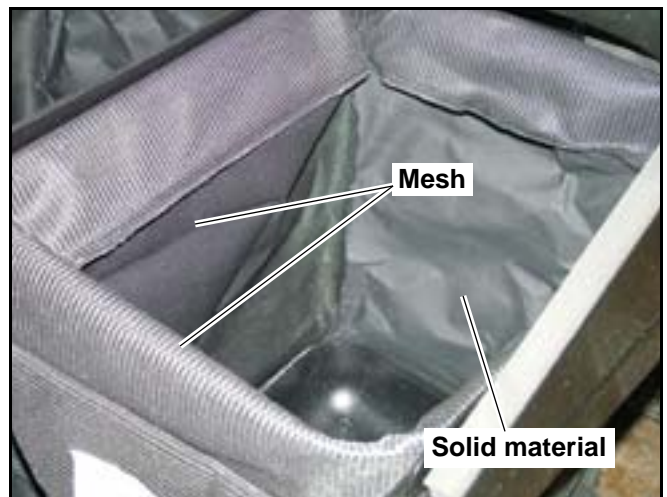

Figure 3-14

remove ignition switch key.

2. Assemble the right mount, left mount, support tube and rear engine guard together using the hardware shown.
3. Remove the rear engine guard from the tractor.
4. Attach the assembly to the tractor.
5. Remove the right drive tire.



WARNING: Never work under the machine or attachment unless it is safely supported with jack stands. Make certain machine is secure when it is raised and placed on the jack stands. The jack stands should not allow the machine to move when the engine is running and the drive wheels are

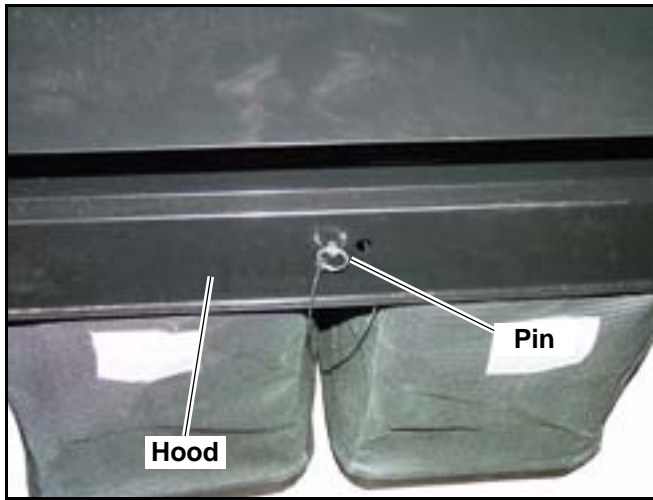

Figure 3-15

rotating. Use only certified jack stands. Use only appropriate jack stands, with a minimum weight rating of 2000 pounds to block the unit up. Use in pairs only. Follow the instructions supplied with the vehicle stands.

6. **If the tractor frame has two pilot holes** located next to the right fuel tank behind the seat then drill two .406 dia. holes through the tractor frame.
If there are no pilot holes located in the tractor frame then use the two holes in the brace as drill guides, locate and drill two .406 dia. holes through the tractor frame. Fig. 3-16
7. Attach the brace to the tractor frame using the hardware.
8. Re-attach the drive tire and torque lug nuts to 65-75 ft.lbs. Lower the tractor.
9. Attach the weights to the tractor per Fig. 3-17.
10. Slide the catcher hood assembly onto the frame mount tube. Fig. 3-11
11. Place the bags in the catcher assembly, making sure that the non-mesh side of the bag is towards the operator, close the hood and insert the pin. Fig. 3-14 & Fig. 3-15



Figure 3-17

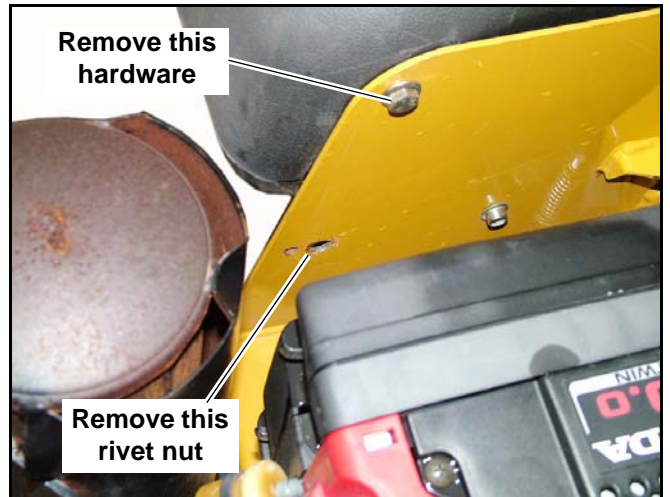

Figure 3-18



Figure 3-16

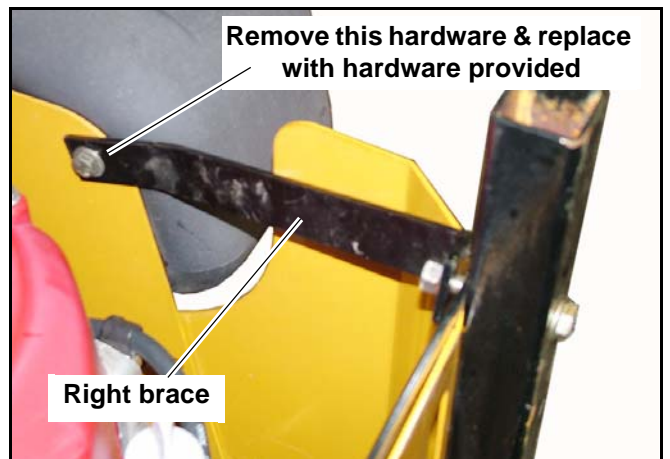

Figure 3-19

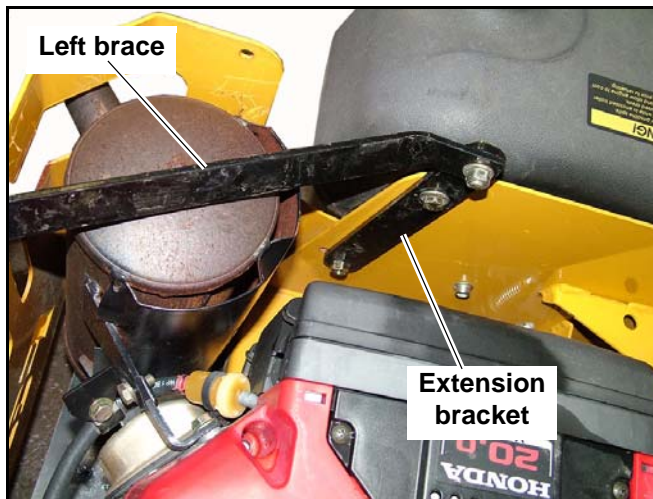

Figure 3-20

Tractor preparation - FasTrak 44/52

NOTE: Refer to illustrated parts listings when assembling the unit.



WARNING: Allow engine and muffler to cool before assembling the unit to the tractor.

1. Park the tractor on a flat surface, place steering control levers in the park brake position, shut-off engine and remove ignition switch key.
2. Remove the rear engine guard from the tractor.
3. Remove the lower left rear rivet nut. Fig. 3-18
4. Remove the left rear upper and lower fuel tank mounting bolts. Fig. 3-18
5. Remove the right rear upper fuel tank mounting bolt. Fig. 3-19
6. Attach the extension bracket to the tractor frame using the hardware.
7. Attach the rear bumper, supplied with this kit, to the tractor using the existing hardware.
8. Assemble the frame mount tube to the rear engine guard using the hardware shown.
9. Assemble the mounting bracket, left brace and right brace to the frame mount tube.
10. Attach the left brace to the extension bracket. Do not tighten the hardware. Fig. 3-20
11. Attach the right brace to the right fuel tank mount using the hardware shown. Do not tighten the hardware. Fig. 3-19
12. Tighten all hardware.
13. Remove the rear flotation wheels from the original rear engine guard and attach them to the new rear engine guard.
14. Remove the operator's foot rest from the tractor. Bolt the weights to each other and then attach them to the tractor per Fig. 3-13. Re-attach the operator's foot rest to the tractor.
15. Slide the catcher hood assembly onto the frame mount tube. Fig. 3-11
16. Place the bags in the catcher assembly, making sure

that the non-mesh side of the bag is towards the operator, close the hood and insert the pin. Fig. 3-14 & Fig. 3-15



Figure 3-21

Tractor preparation - FasTrak Super Duty 48"/54"/60"

NOTE: Refer to illustrated parts listings when assembling the unit.



WARNING: Allow engine and muffler to cool before assembling the unit to the tractor.

1. Park the tractor on a flat surface, place steering control levers in the park brake position, shut-off engine and remove ignition switch key.
2. Attach heat shield to the frame mount tube.
3. Attach the frame mount tube to the rear engine guard.
4. Attach the mounting bracket and bumper support to the frame mount tube.
5. Remove the right drive tire.



WARNING: Never work under the machine or attachment unless it is safely supported with jack stands. Make certain machine is secure when it is raised and placed on the jack stands. The jack stands should not allow the machine to move when the engine is running and the drive wheels are rotating. Use only certified jack stands. Use only appropriate jack stands, with a minimum weight rating of 2000 pounds to block the unit up. Use in pairs only. Follow the instructions supplied with the vehicle stands.

6. Attach the bumper support to the two holes located in the tractor frame behind the right fuel tank using the hardware shown. Fig. 3-21
7. Slide the catcher hood assembly onto the frame mount tube. Fig. 3-11
8. Slide the exhaust extension onto the muffler exhaust tube. Rotate the extension so the hole is located on bottom and drill a 5/32" dia. hole in the muffler

tailpipe. Attach the exhaust extension using the screw.

9. Re-attach the drive tire and torque lug nuts to 65-75 ft.lbs. Lower the tractor.

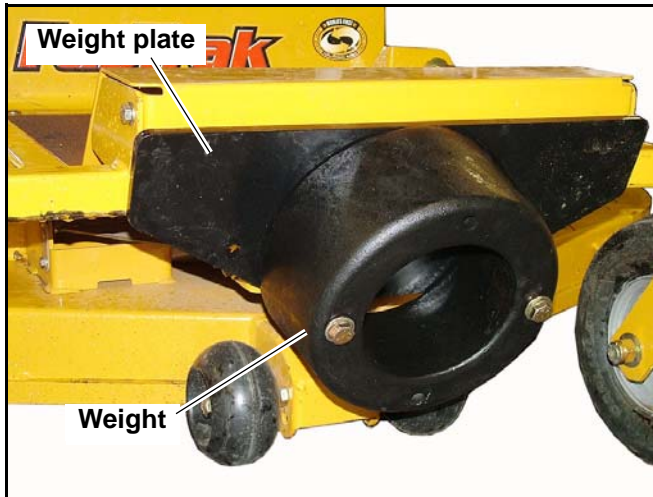

Figure 3-22

10. Attach the weight plate and weight to the tractor per Fig. 3-22
11. Place the bags in the catcher assembly, making sure that the non-mesh side of the bag is towards the operator, close the hood and insert the pin. Fig. 3-14 & Fig. 3-15

Final Connection

1. Slide the two tubes together. Fig. 3-23
Insert the upper tube into the catcher hood and orientate per Fig. 3-24.
2. Slide the lower tube onto the blower housing tube. Fig. 3-2
3. Set the deck in the lowest position. Make sure the upper tube is orientated properly. Fig. 3-24
Locate and drill a 9/32" diameter hole through both tubes. Fig. 3-26
4. Remove the lower tube from the blower housing tube and bolt the two tubes together.
5. Slide the lower tube onto the blower housing tube and secure in place using the bungee cord. Fig. 3-25
NOTE: It will be necessary to raise the blower hood and slide the upper tube farther into the blower area to allow the lower tube to slide over the blower housing tube. After sliding the tubes down make sure that the upper tube is still orientated correctly and close the blower hood.
6. Reconnect the negative battery cable.

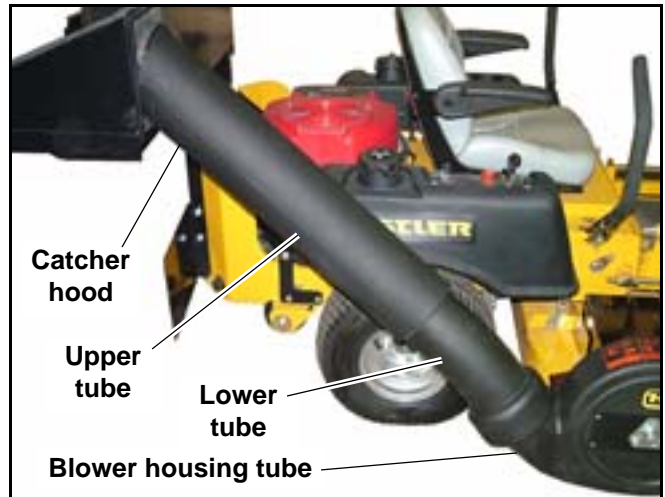

Figure 3-23



Figure 3-24

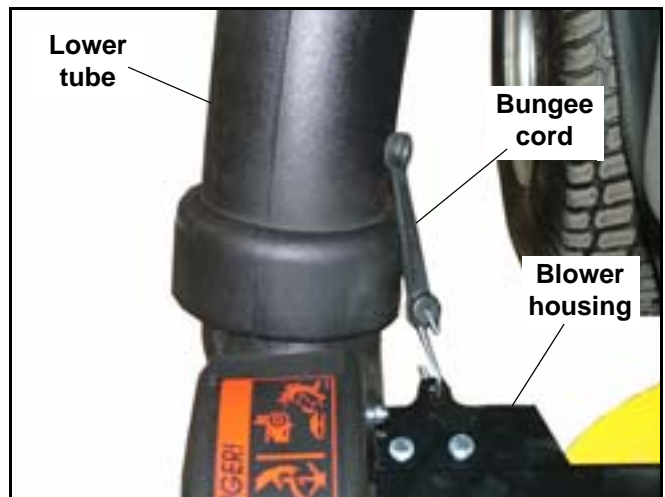

Figure 3-25

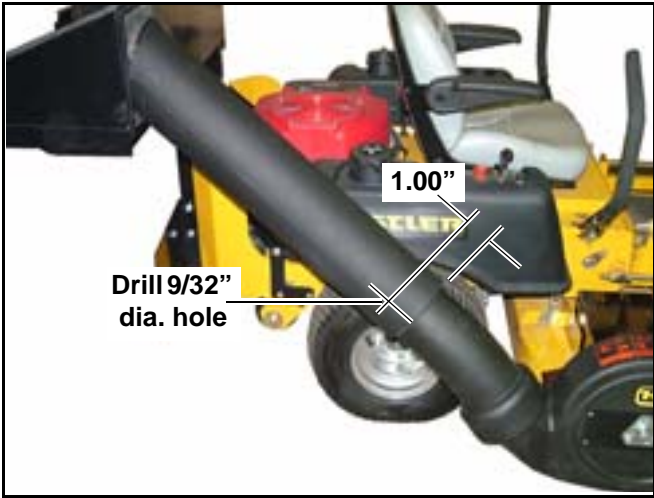

Figure 3-26

OPERATION

Vacuum pickup and collection

Follow normal tractor and mower deck start-up and operating procedures as outlined in the tractor owner's manual. The blower assembly will operate when the mower deck clutch switch is engaged. To stop the blower assembly, return the deck clutch switch to the disengaged position.

Proceed to mow in the normal manner and occasionally glance at the window located in the upper front of the catcher hood (Fig. 4-1). The window is designed to allow the operator to see when the bags are getting full. When the bags are filled, move the deck clutch switch to the disengaged position. Then drive the machine to the unloading area.

It is best that the bags be unloaded before the blower and tube areas become clogged. If clogging occurs, it will be necessary to clean the blower and tube areas of all material before starting to mow again.



Figure 4-1



WARNING: Make certain the engine is turned off, the steering control levers are in the park brake position and the ignition key is removed from the ignition switch before cleaning the blower and chute areas.



WARNING: Never place hands or feet into the blower housing spout. There is an impeller located inside the housing that will cause severe injury. Use a probe to clean debris from spout.



WARNING: Never engage mower deck unless both bags are installed and the hood is lowered. Also, both transfer tubes must be in place on the blower outlet and the hood assembly and the bungee cord is connected. Fig. 3-20 & Fig. 3-22

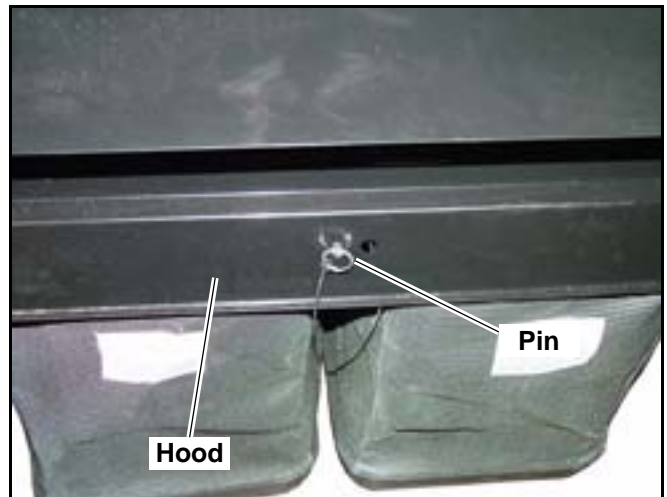

Figure 4-2

When the bags are full, turn the deck and the blower off (deck clutch switch in the disengaged position). Then drive the machine to the unloading area.

Unloading



WARNING: Make certain the deck clutch switch is in the disengaged position before unloading.

Park the unit on a level surface, shut the engine off and place the steering control levers in the park brake position.

Get off the tractor, remove the pin from the hood assembly. Raise the hood and remove the bags and dump them. Fig. 4-2

Return the bags to the catcher assembly, making sure that the non-mesh side of the bag is towards the operator, close the hood and re-insert the pin. Fig. 4-2 & Fig. 4-3

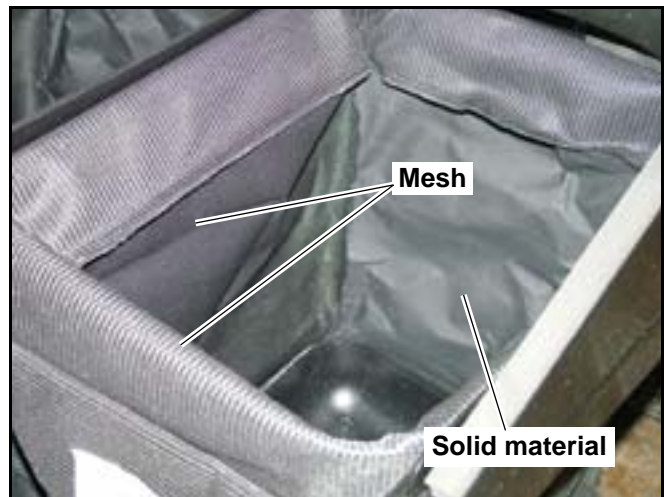

Figure 4-3

MAINTENANCE

Blower housing and transfer tube



WARNING: Never work on the blower assembly or mower deck when the tractor engine is running.



WARNING: Clean flammable material from machine. Prevent fires by keeping engine compartment, top of deck, exhaust area, battery, hydraulic lines, fuel line, fuel tank and operator's station clean of accumulated trash, grass clippings, and other debris. Always clean up spilled fuel and oil.

The blower and tubes (Fig. 5-1) should be kept clean and free of any accumulation of matted clippings or other obstructions. Occasional clogging may also occur when working in heavy, wet or matted grass.



WARNING: Never place hands or feet into the blower housing spout. There is an impeller located inside the housing that will cause severe injury. Use a probe to clean debris from spout.



WARNING: Never engage mower deck unless both bags are installed and the hood is lowered. Also, both transfer tubes must be in place on the blower outlet and the hood assembly and the bungee cord is connected. Fig. 3-19 & Fig. 3-23

To service the blower housing: remove the belt cover and unbolt the housing from the deck.

To service the transfer tubes, remove the upper and lower tubes from the unit. The tubes can be cleaned by using soapy water and washing the inside of the tubes with a pressure washer. Rinse with water.

To clean the bags, hand wash with soap and water, rinse with clean water.

Blower drive belt

The blower drive belt (Fig. 5-2) is located under the belt cover. This belt is spring tensioned and should not need adjustment.

When belt replacement becomes necessary, check the condition of the pulleys. Clean the grooves and check for excessive wear. A new belt should not run against the bottom of groove. If it does bottom out, the the pulley needs replacing.

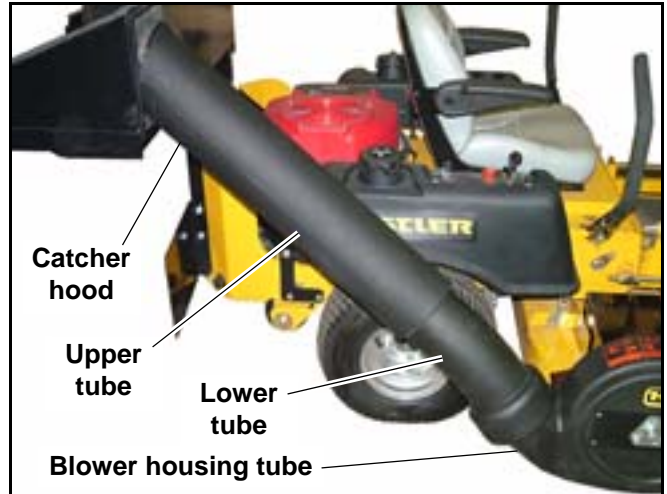

Figure 5-1

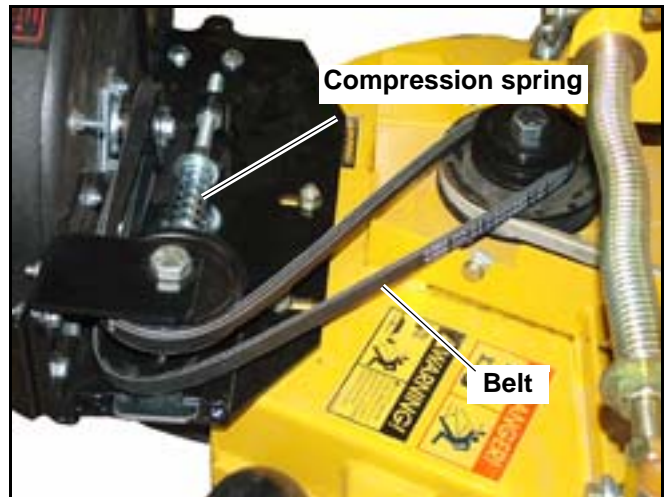

Figure 5-2

STORAGE

When your mower is to set idle for a period of time, scrape and remove the matted grass material from inside the hood and clean the bags. Clean the discharge area in the blower assembly likewise. A light coating of oil applied to these surfaces will help retard rusting.

Check for loose or missing hardware, tighten or replace. Also check for badly worn or damaged parts, consider replacing them at this time. Touch up chipped paint areas, your Hustler dealer has aerosol spray paint available.

Illustrated Parts List

Blower Assembly–108194	7-3
Catcher Assembly	7-5
Chute Assembly.	7-7
Mini Z/FasTrak Super Duty, 36”/42” Catcher Mount	7-9
FasTrak 48”/54” Catcher Mount.	7-10
FasTrak 48”/54” Catcher Mount.	7-11
FasTrak Super Duty 48”/54”/60” Catcher Mount	7-13
FasTrak 48”/FasTrak Super Duty 48” Adaptor Kit (109836)	7-14
FasTrak 48”/FasTrak Super Duty 48” Adaptor Kit (109836)	7-15
FasTrak 54”/FasTrak Super Duty 54” Adaptor Kit (109835)	7-16
FasTrak 54”/FasTrak Super Duty 54” Adaptor Kit (109835)	7-17
FasTrak Super Duty 60” Adaptor Kit (109994)	7-18
FasTrak Super Duty 60” Adaptor Kit (109994)	7-19
FasTrak Weights	7-20
FasTrak Weights	7-21

Blower Assembly-108194

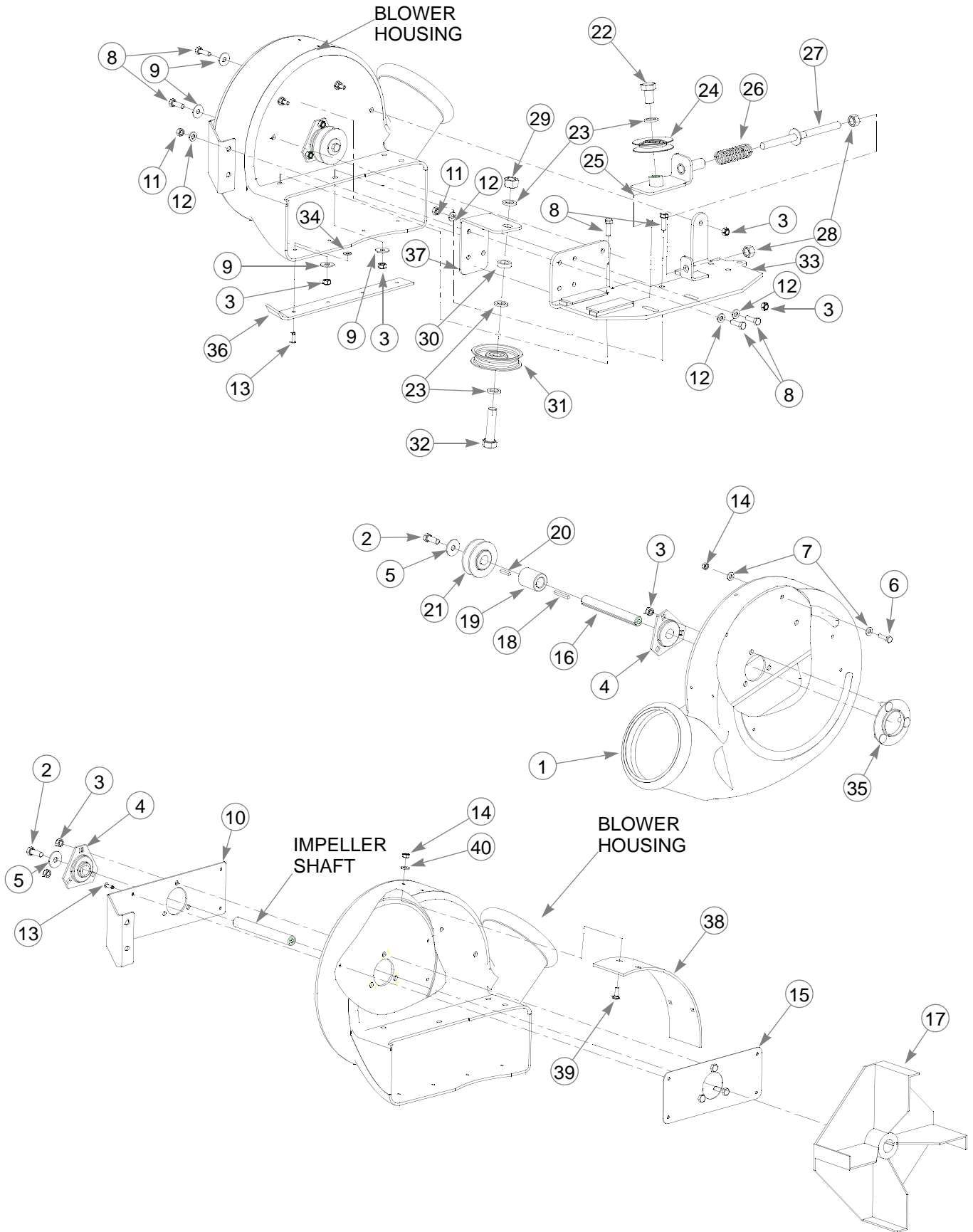

Blower Assembly-108194

INDEX NO.	PART NO.	QTY.	DESCRIPTION
1	601080	1	BLOWER HOUSING
2	036244	2	CS .375-16 X 1.00 HX G5
3	058776	10	NT .312-18 HXZY NL
4	601071	2	IMPELLER SHAFT BEARING
5	705137	2	FW .391 X 1.250 X .060 ZNYC
6	056077	2	CS .250-20 X 1.00 HX G5
7	025403	4	FW .281 X .625 X .062 ZNYC
8	036236	8	CS .312-18 X 1.00 HX G5
9	079210	4	FW .344 X 1.00 X .06 ZNYC
10	108169	1	OUTER BLOWER HOUSING BRACKET
11	034272	4	NT .312-18 HX G5 ZNYC
12	768523	8	FW .343 X .687 X .051/.080 HD
13	760140	8	RIVET .187 X .375 X .375 H
14	024927	6	NT .250-20 HX GR.5 ZNYC
15	108167	1	INNER BEARING PLATE
16	108165	1	IMPELLER SHAFT
17	601239	1	IMPELLER
18	322537	1	KEY .187 SQ X 1.50 LONG
19	601073	1	IMPELLER SHAFT SPACER
20	392217	1	KEY .187 SQ X .90 LONG
21	601070	1	IMPELLER SHAFT PULLEY
22	016626	1	CS .625-11 X 1.00 HX ZNYC
23	028118	4	FW .625 X 1.00 X .134 ZNYC
24	601065	1	INSIDE IDLER PULLEY
25	108187	1	CLEVIS
26	601076	1	COMPRESSION SPRING, 1 X 4.25
27	108191	1	GUIDE ROD
28	067918	2	NT .500-13 HX G8 ZNYC
29	016972	1	NT .625-11 HX G5 ZNYC
30	600296	1	DECK IDLER SPACER
31	791566	1	IDLER PULLEY 3.25"OD X .6
32	025015	1	CS .625-11 X 2.50 HX G5
33	108193	1	BLOWER PLATE
34	007567	4	FW .208 X .59 X .051 ZN
35	109152	1	RETAINER
36	108168	1	BLOWER HOUSING STIFFNER
37	108185	1	IDLER MOUNT BRACKET
38	108892	1	BLOWER LINER
39	794784	4	CB .250-20 X .75 FUL ZN
40	768515	4	FW .281 X .625 X .051/.080 HD

NOTES:

1. Included in 928408, 928960, and 928986.

Catcher Assembly

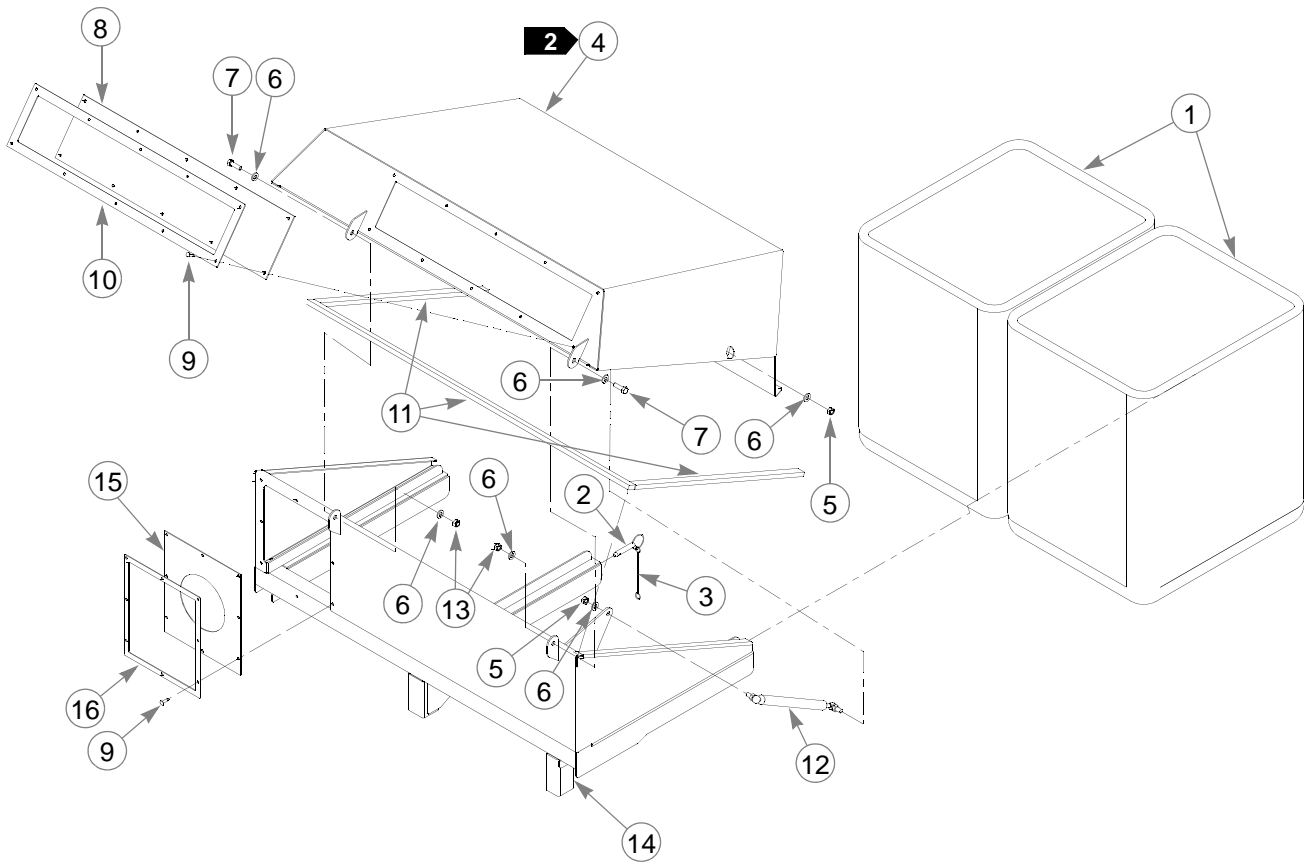

Catcher Assembly

INDEX NO.	PART NO.	QTY.	DESCRIPTION
1	601236	2	CATCHER BAG
2	601223	1	LATCH PIN
3	601224	1	LATCH LANYARD
4	108733	1	HOOD ASSEMBLY
5	034272	2	NT .312-18 HX G5 ZNYC
6	768523	6	FW .343 X .687 X .051/.080 HD
7	036236	2	CS .312-18 X 1.00 HX G5
8	108741	1	SIGHT WINDOW
9	760140	18	RIVET .187 X .375 X .375 H
10	108742	1	SIGHT WINDOW RETAINER
11	713198	6.3 FT	SEAL 3/8 X 3/4
12	601241	1	GAS SPRING, HOOD LIFT
13	058776	2	NT .312-18 HXZY NL
14	108730	1	FRAME
15	108712	1	INLET GASKET
16	108713	1	INLET FLANGE

NOTES:

1. Included in 928408, 928960, and 928986.
2. Includes Items 8 (Sight Window) and 10 (Sight Window Retainer).

Chute Assembly

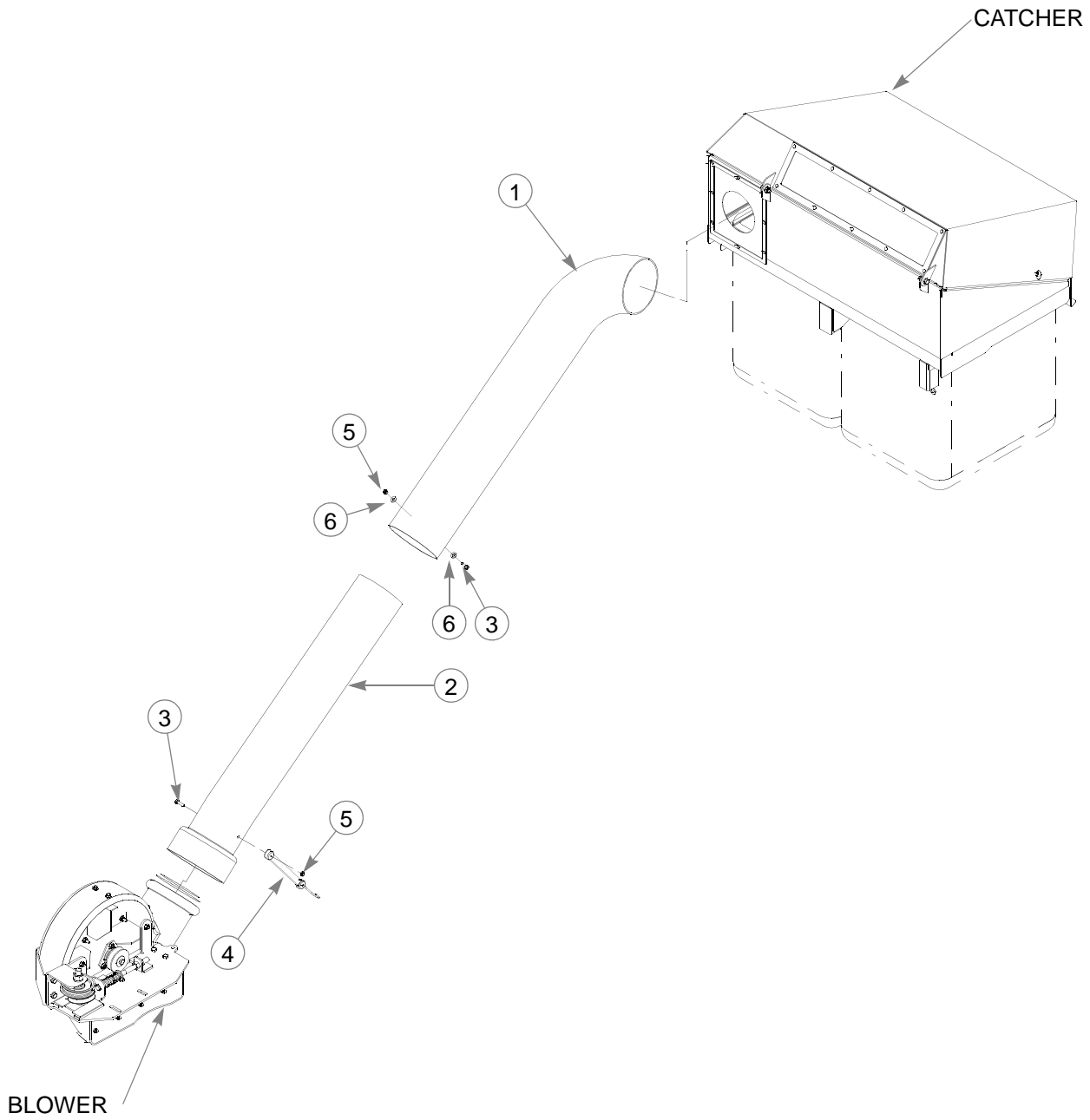

Chute Assembly

INDEX NO.	PART NO.	QTY.	DESCRIPTION
1	601228	1	UPPER TRANSITION TUBE
2	601229	1	LOWER TRANSITION TUBE
3	056077	2	CS .250-20 X 1.00 HX G5
4	601230	1	BUNGEE STRAP LATCH
5	068551	2	NT .250-20 HXZY NL
6	768515	2	FW .281 X .625 X .051/.080 HD

NOTES:

1. Included in 928408, 928960, and 928986.

Mini Z/FasTrak Super Duty, 36"/42" Catcher Mount

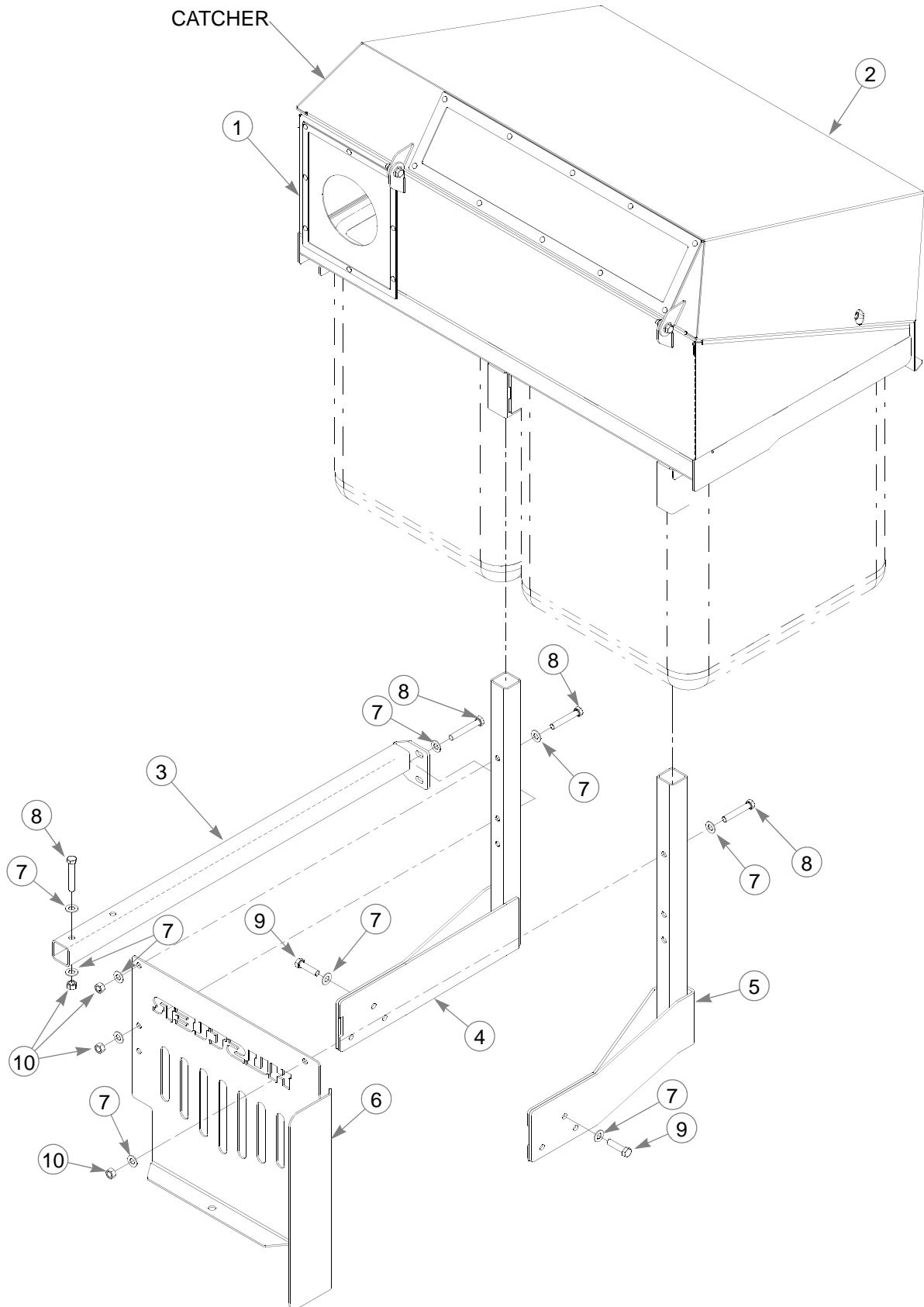

Mini Z/FasTrak Super Duty, 36"/42" Catcher Mount

INDEX NO.	PART NO.	QTY.	DESCRIPTION
1	110849	1	2 BAG CATCHER FRAME
2	100850	1	2 BAG CATCHER HOOD
3	109099	1	SUPPORT TUBE
4	109097	1	RH MOUNT
5	109098	1	LH MOUNT
6	109089	1	HEAT SHIELD
7	767954	20	FW .406 X .812 X .060 SAE
8	056036	7	CS .375-16 X 2.250 HX G5
9	080655	6	CS .375-16 X 1.50 HX G5
10	054502	9	NT .375-16 HX GRD 5 ZNYC

NOTES:

1. Supplied with 928986.

FasTrak 48"/54" Catcher Mount

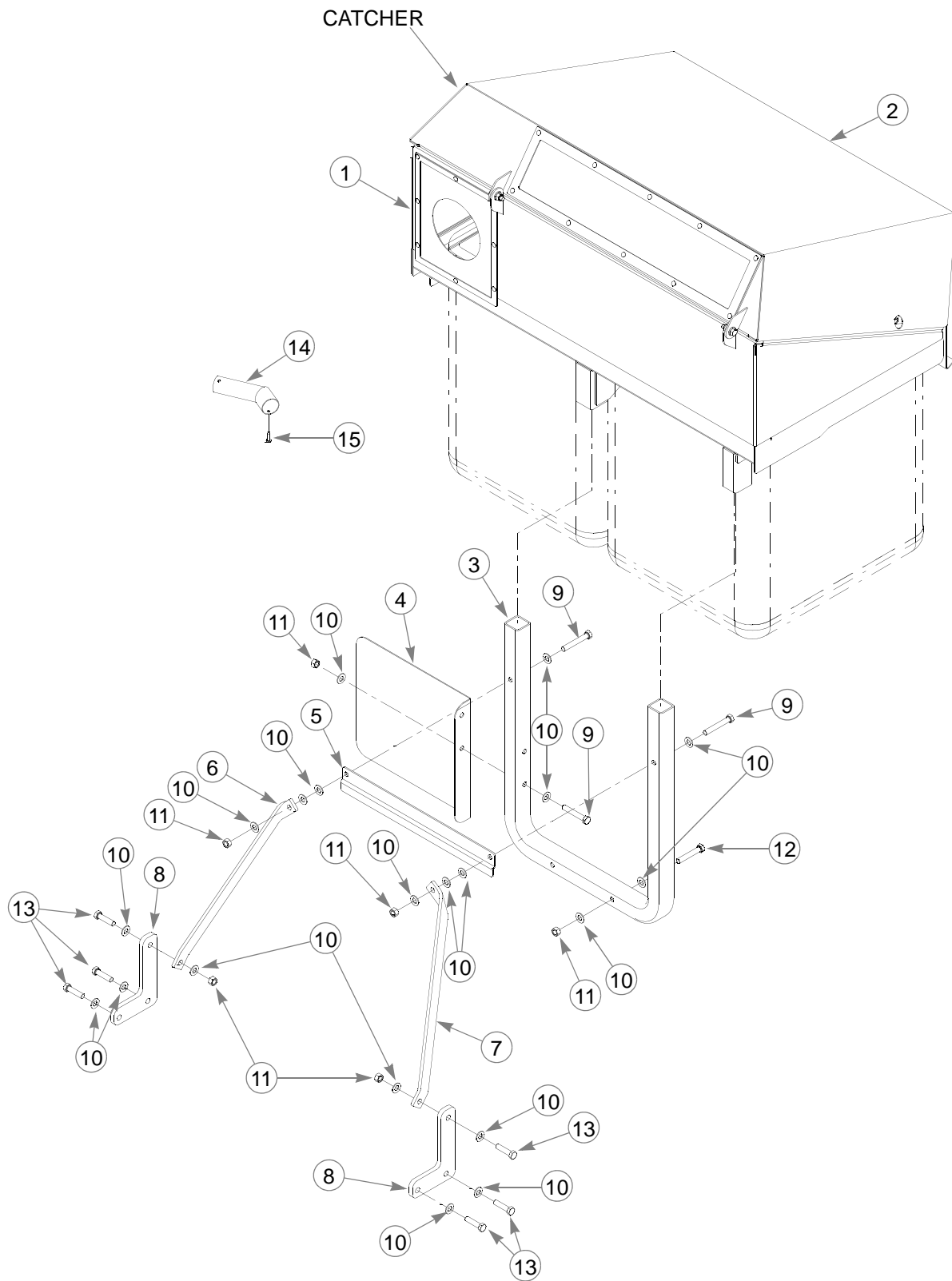

FasTrak 48"/54" Catcher Mount

INDEX NO.	PART NO.	QTY.	DESCRIPTION
1	110849	1	2 BAG CATCHER FRAME
2	110850	1	2 BAG CATCHER HOOD
3	108171	1	FRAME MOUNTING TUBE
4	108818	1	HEAT SHIELD
5	108222	1	MOUNTING BRACKET
6	108220	1	CATCHER BRACE
7	108219	1	CATCHER BRACE
8	107924	2	CATCHER BRACE BASE
9	016428	4	CS .375-16 X 2.50 HX GR5
10	767954	26	FW .406 X .812 X .060 SAE
11	054502	2	NT .375-16 HX GRD 5 ZNYC
12	056036	2	CS .375-16 X 2.250 HX G5
13	080655	6	CS .375-16 X 1.50 HX G5
14	378760	1	TAIL PIPE EXTENSION
15	769299	1	SC #10 X .750 PHILLIPS TH

NOTES:

1. Supplied with 928960.

FasTrak Super Duty 48"/54"/60" Catcher Mount

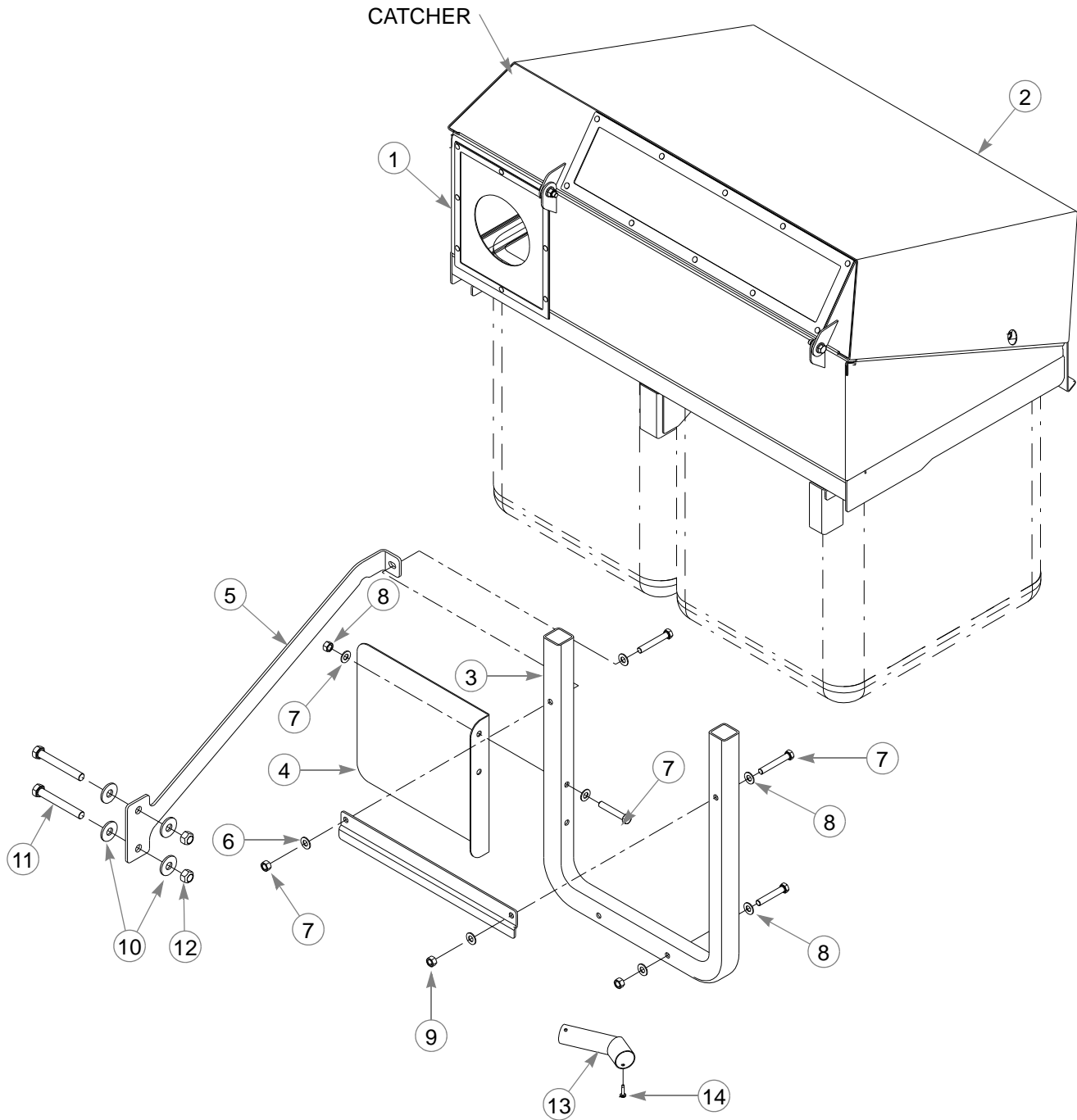

FasTrak Super Duty 48"/54"/60" Catcher Mount

INDEX NO.	PART NO.	QTY.	DESCRIPTION
1	110849	1	2 BAG CATCHER FRAME
2	110850	1	2 BAG CATCHER HOOD
3	108171	1	FRAME MOUNTING TUBE
4	108818	1	HEAT SHIELD
5	109612	1	BUMPER SUPPORT
6	109641	1	MOUNTING BRACKET
7	056036	6	CS .375-16 X 2.250 HX GR5
8	767954	12	FW .406 X .812 X .060 SAE
9	054502	6	NT .375-16 HX GRD 5 ZNYC
10	712976	4	FW .531 1.375 X .125 ZN/711
11	068023	2	CS .500-13 X 3.75 HX GR8 ZN
12	023317	2	NT .500-13 UNT LK G5 ZN
13	378760	1	TAIL PIPE EXTENSION
14	769299	1	SC #10 X .750 PHILLIPS TH

NOTES:

1. Supplied with 928960

FasTrak 48"/FasTrak Super Duty 48" Adaptor Kit (109836)

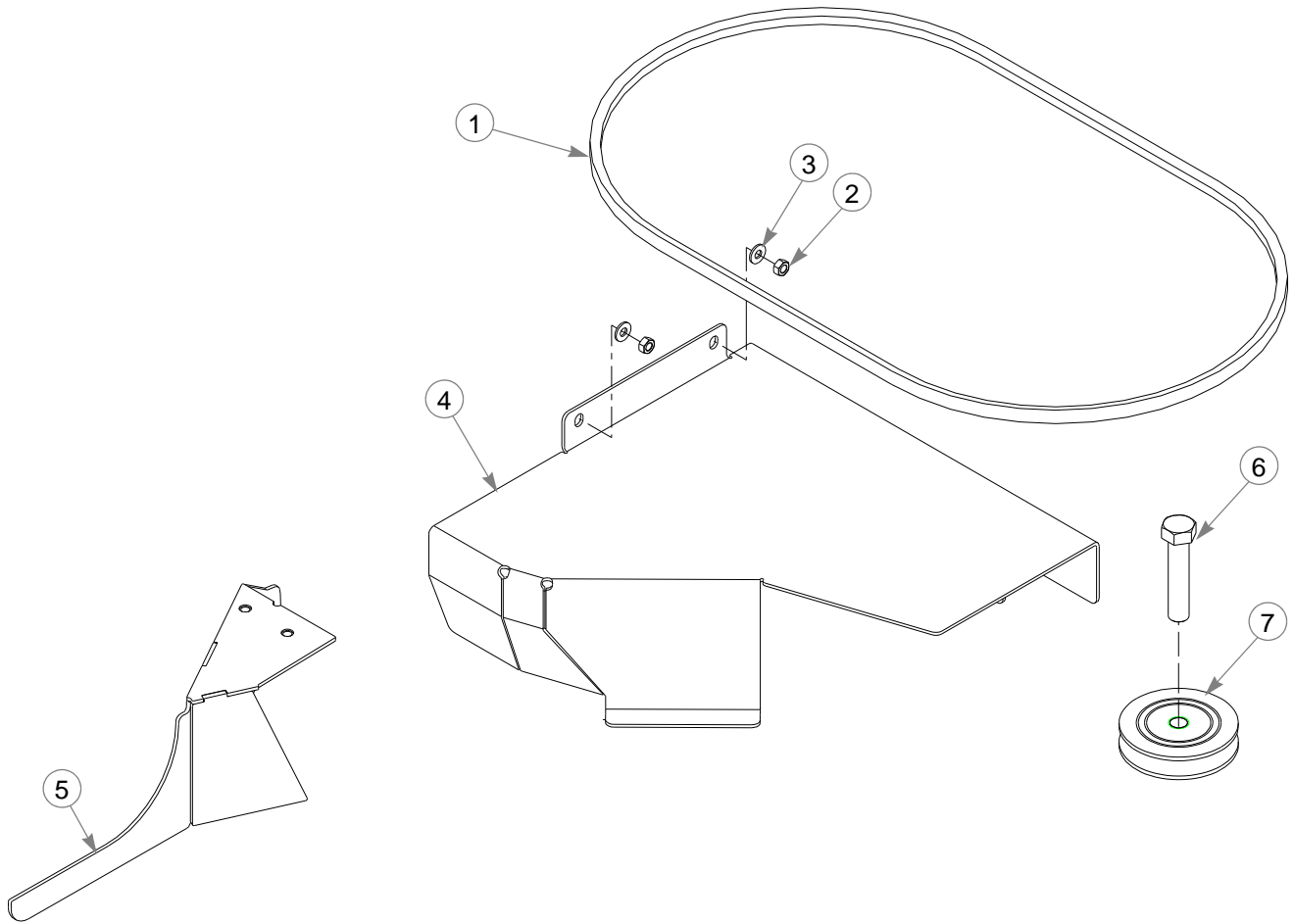

FasTrak 48"/FasTrak Super Duty 48" Adaptor Kit (109836)

INDEX NO.	PART NO.	QTY.	DESCRIPTION
1	601231	1	BELT, 4L-SEC 54.79 EL
2	024927	2	NT .250-20 HX GR.5 ZNYC
3	025403	2	FW .281X .625X.062 ZNYC
4	108718	1	BELT COVER
5	109102	1	BLOWER BAFFLE
6	783738	1	CS .625-11 X 3.00 FULL HX
7	601226	1	DRIVE PULLEY

NOTES:

FasTrak 54"/FasTrak Super Duty 54" Adaptor Kit (109835)

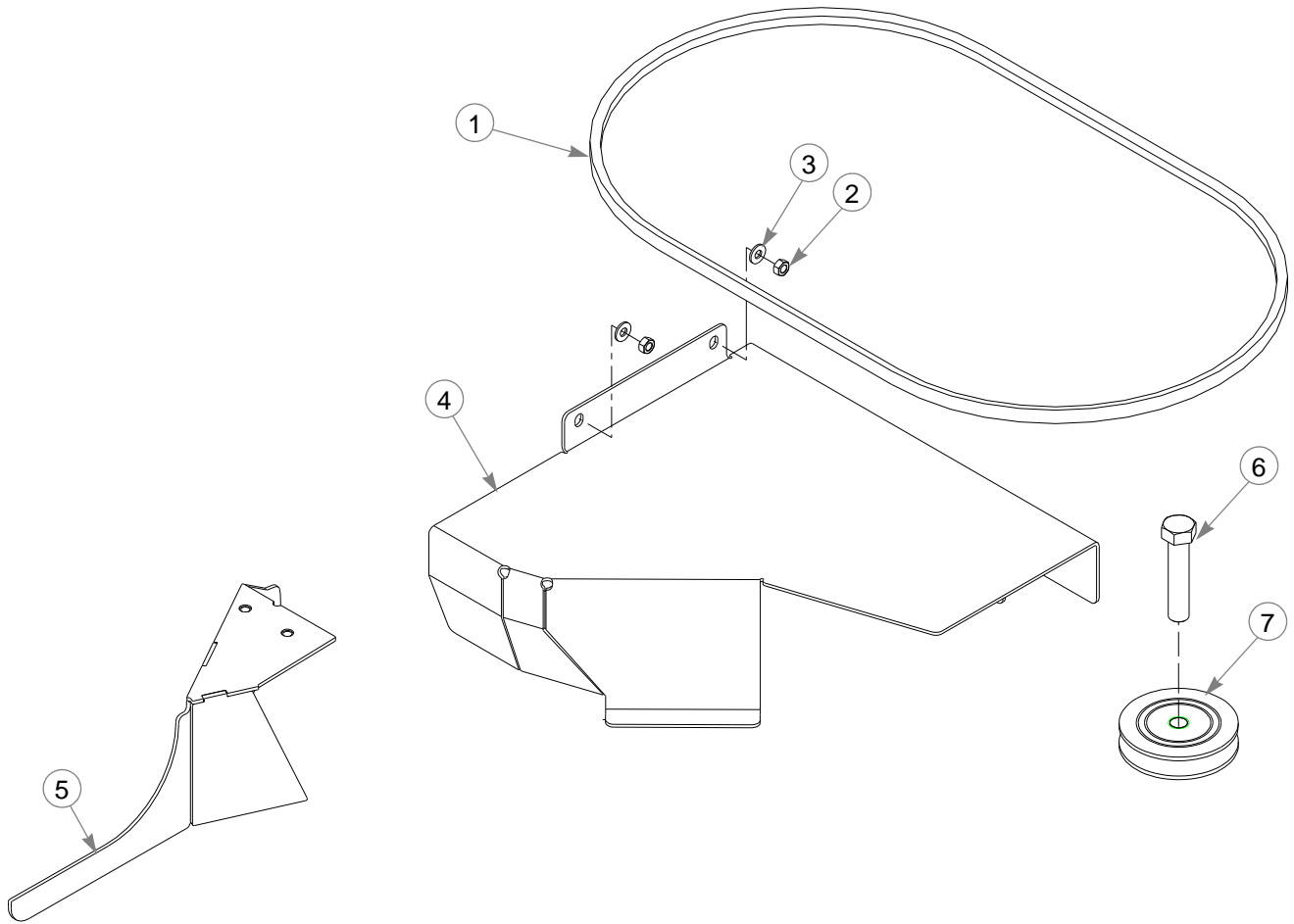

FasTrak 54"/FasTrak Super Duty 54" Adaptor Kit (109835)

INDEX NO.	PART NO.	QTY.	DESCRIPTION
1	601232	1	BELT, 4L-SEC 57.79 EL
2	024927	2	NT .250-20 HX GR.5 ZNYC
3	025403	2	FW .281X .625X.062 ZNYC
4	108717	1	BELT COVER
5	109102	1	BLOWER BAFFLE
6	783738	1	CS .625-11 X 3.00 FULL HX
7	601227	1	DRIVE PULLEY

NOTES:

FasTrak Super Duty 60" Adaptor Kit (109994)

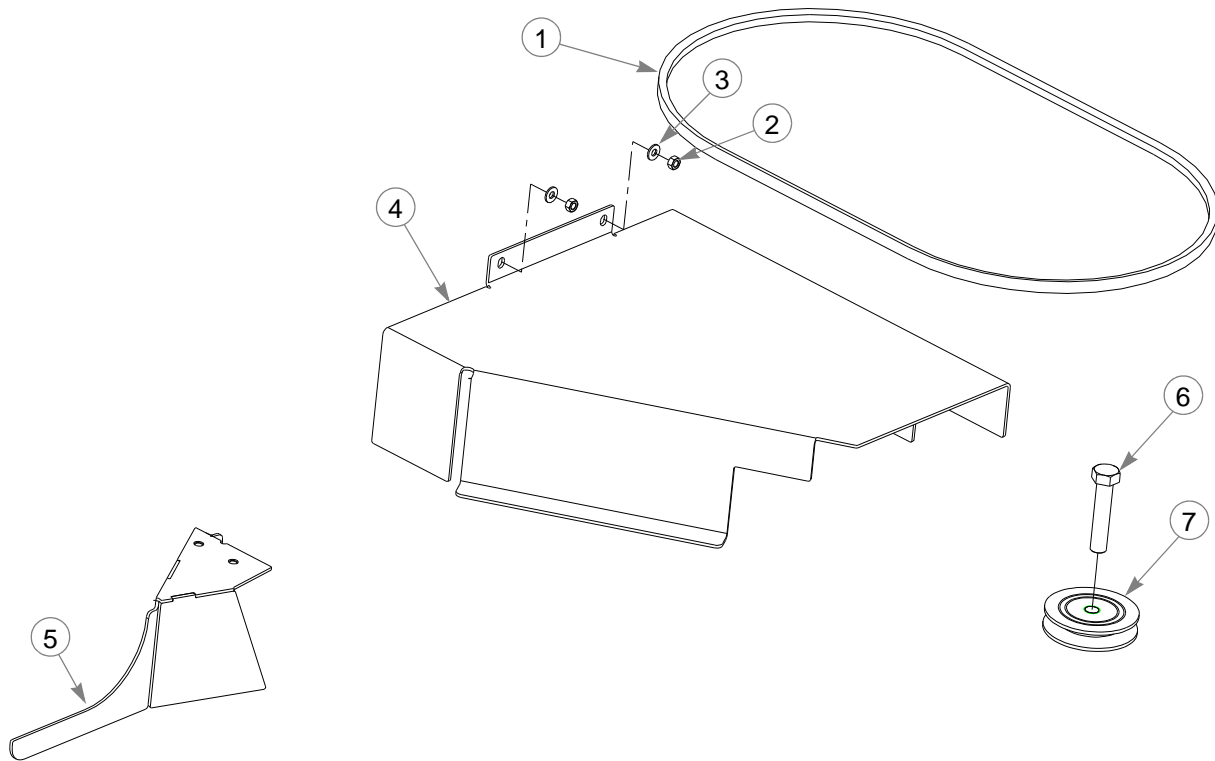

FasTrak Super Duty 60" Adaptor Kit (109994)

INDEX NO.	PART NO.	QTY.	DESCRIPTION
1	601667	1	BELT, 4L-SEC 60.79 EL
2	024927	2	NT .250-20 HX GR.5 ZNYC
3	025403	2	FW .281X .625X.062 ZNYC
4	109995	1	BELT COVER
5	109998	1	BLOWER BAFFLE
6	783738	1	CS .625-11 X 3.00 FULL HX
7	601227	1	DRIVE PULLEY

NOTES:

FasTrak Weights

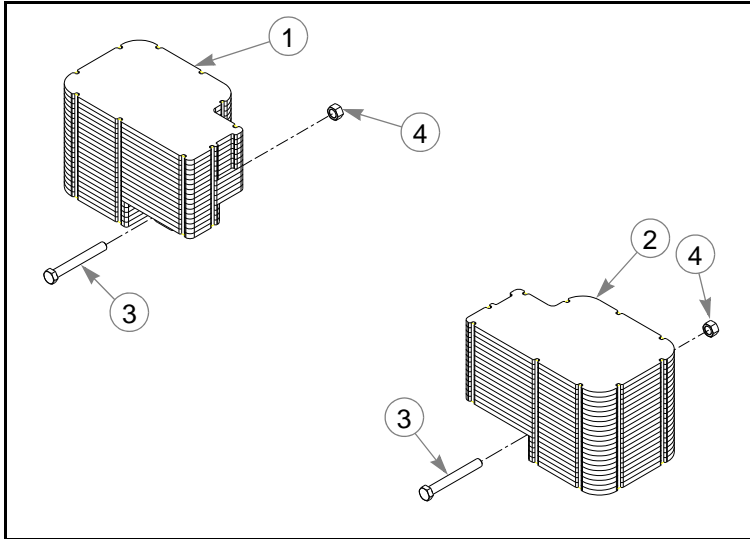

36"/42" FasTrak Super Duty

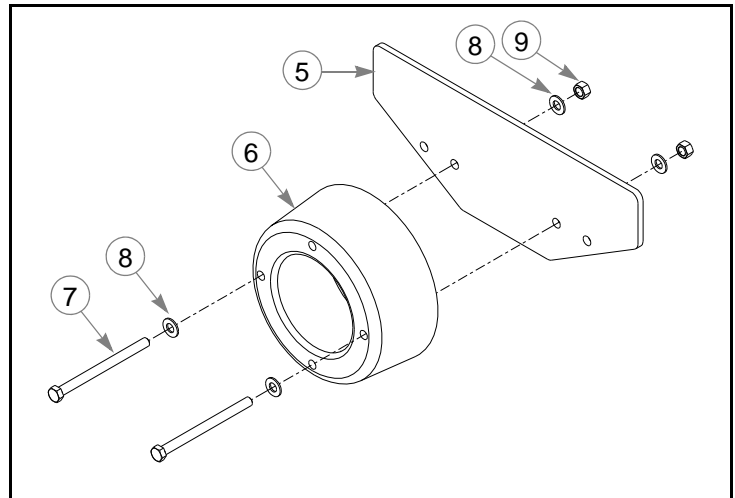

48"/54" FasTrak/48"/54"/60" Super Duty

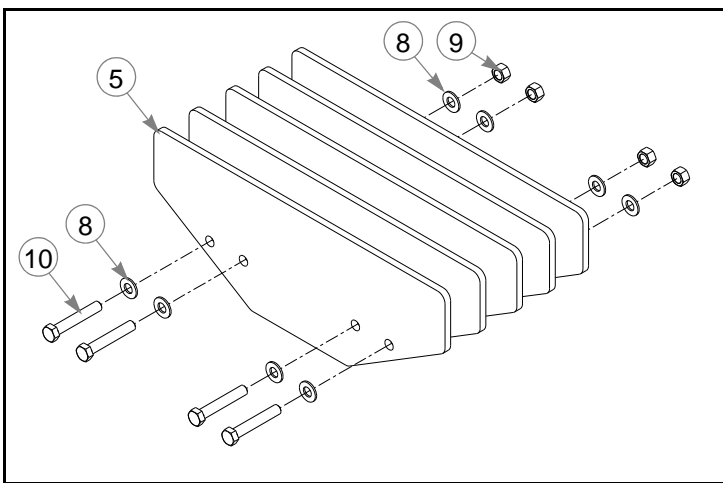

44"/52" FasTrak

FasTrak Weights

INDEX NO.	PART NO.	QTY.	DESCRIPTION
1	108489	1	RIGHT WEIGHT
2	108488	1	LEFT WEIGHT
3	016444	2	CS .375-16X3.0 HX G5 ZN
4	054502	2	NT .375-16 HX GRD 5 ZNY
5	104489	6	FST WEIGHT PLATE
6	789214	1	WHEEL WEIGHT MMZ
7	042630	2	CS .500-13X6.50 HX G5 Z
8	767962	12	FW .531X 1.063X.090 SAE
9	008193	6	NT .500-13 HX G5 ZNYC
10	016568	4	CS .500-13X3.000 HX ZN

NOTES:

1. Weights supplied w/catcher.

Index

Part Numbers

007567	7-3	108742	7-5
008193	7-21	108818	7-11, 7-13
016428	7-11	108892	7-3
016444	7-21	109089	7-9
016568	7-21	109097	7-9
016626	7-3	109098	7-9
016972	7-3	109099	7-9
023317	7-13	109102	7-15, 7-17
024927	7-3, 7-15, 7-17, 7-19	109152	7-3
025015	7-3	109612	7-13
025403	7-3, 7-15, 7-17, 7-19	109641	7-13
028118	7-3	109995	7-19
034272	7-3, 7-5	109998	7-19
036236	7-3, 7-5	110849	7-9, 7-11, 7-13
036244	7-3	110850	7-11, 7-13
042630	7-21	322537	7-3
054502	7-9, 7-11, 7-13, 7-21	378760	7-11, 7-13
056036	7-9, 7-11, 7-13	392217	7-3
056077	7-3, 7-7	600296	7-3
058776	7-3, 7-5	601065	7-3
067918	7-3	601070	7-3
068023	7-13	601071	7-3
068551	7-7	601073	7-3
079210	7-3	601076	7-3
080655	7-9, 7-11	601080	7-3
100850	7-9	601223	7-5
104489	7-21	601224	7-5
107924	7-11	601225	7-15, 7-17, 7-19
108165	7-3	601226	7-15
108167	7-3	601227	7-17, 7-19
108168	7-3	601228	7-7
108169	7-3	601229	7-7
108171	7-11, 7-13	601230	7-7
108185	7-3	601231	7-15
108187	7-3	601232	7-17
108191	7-3	601236	7-5
108193	7-3	601239	7-3
108219	7-11	601241	7-5
108220	7-11	601667	7-19
108222	7-11	705137	7-3
108488	7-21	712976	7-13
108489	7-21	713198	7-5
108712	7-5	760140	7-3, 7-5
108713	7-5	767954	7-9, 7-11, 7-13
108717	7-17	767962	7-21
108718	7-15	768515	7-3, 7-7
108730	7-5	768523	7-3, 7-5
108733	7-5	769299	7-11, 7-13
108741	7-5	789214	7-21
		791566	7-3
		794784	7-3
		B	
		Blower drive belt	5-1

Blower housing and transfer tube	5-1	Parts list - 928986	3-1
D		S	
Deck adapter kits	3-1	Safety Precautions	2-1
F		Storage	6-1
FasTrak 44 Adapter Kit	1-1	T	
FasTrak 52 Adapter Kit	1-1	To the new owner	1-1
FasTrak Super Duty 48	1-1	Tractor Preparation	3-3
FasTrak Super Duty 60 Adapter Kit	1-1	U	
Final Connection	3-8	Unloading	4-1
M		Using this manual	1-1
Mower deck preparation	3-3	V	
P		Vacuum pickup and collection	4-1
Parts and service	1-1	W	
Parts list - 928408	3-1	Warranty registration	1-1
Parts list - 928960	3-1		