

Hustler® Raptor® SD General Service Manual



HUSTLER®
TURF EQUIPMENT

200 South Ridge Road

Hesston, Kansas

67062

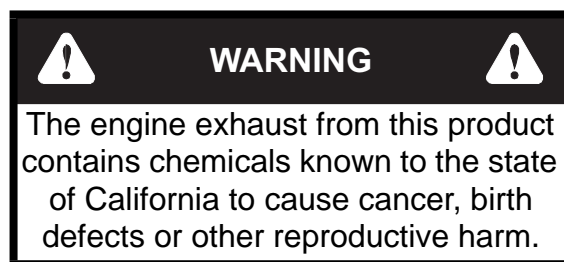

NOTICE OF REQUIREMENT OF SPARK ARRESTER MUFFLER

This equipment may create sparks that can start fires around dry vegetation. California Public Resources Code Section 4442.6 provides that it is unlawful to use or operate an internal combustion engine on any forest-covered, brush-covered, or grass-covered land unless the engine is equipped with a spark arrester maintained in effective working order. A spark arrester is a device constructed of nonflammable materials specifically for the purpose of removing and retaining carbon and other flammable particles over 0.0232 of an inch in size from the exhaust flow of an internal combustion engine that uses hydrocarbon fuels or which is qualified and rated by the United States Forest Service. Other states or federal areas may have similar laws. The Operator Should Contact Local Fire Agencies For Laws or Regulations Relating to Fire Prevention Requirements. **THIS EQUIPMENT DOES NOT HAVE A SPARK ARRESTER AND YOU SHOULD CONTACT YOUR AUTHORIZED DEALER FOR THE PURCHASE OF A SPARK ARRESTER.**

Inspect spark arrester daily; replace every 500 hours or as needed.

The Engine Owner's Manual provides information regarding the U.S. Environmental Protection Agency (EPA) and the California Emission Control Regulation of emission systems, maintenance and warranty.

Keep Engine Owner's Manual with your unit. Should the Engine Owner's Manual become damaged or illegible, replace immediately. Replacements may be ordered per the information found in the Product Information section of the owner's manual.

Federal law and California State law prohibit the following acts or the causing thereof:

1. The removal or rendering inoperative by any person other than for purposes of maintenance, repair, replacement, of any device or element of design incorporated into any equipment for the purposes of emissions control prior to or after its sales or delivery to the ultimate purchaser or while it is in use, or
2. The use of the equipment after such device or element of design has been removed or rendered inoperative by any person.

Table of Contents

General Information	1-1
Hustler® Service Program	1-1
Maintenance Introduction	1-1
Warranty	1-1
Safety	2-1
Safe Servicing Practices	2-1
Pre-Operation Precautions	2-1
Operation Precautions	2-2
Operate Machine Safely	2-2
General Maintenance Precautions	2-2
Maintenance Precautions	2-2
Torque	3-1
Standard Torques	3-1
Special Torques	3-1
Power Unit Maintenance	4-1
Steering Adjustments	4-1
Park Brake Spring Adjustment	4-3
Transaxle Drive Belt	4-3
Hydraulic System	4-5
Tires	4-7
Engine Maintenance	5-1
General Engine Maintenance	5-1
Engine Oil and Filter	5-1
Engine Air Filter	5-1
Carbon canister	5-1
Fuel evaporation system filter	5-1
Engine RPM Settings	5-3
Deck Adjustments	6-1
Deck Leveling	6-1
Blades	6-2

Deck Belt	6-3
48"/54"/60" Deck Belt Routing	6-6
Electrical	7-1
Electrical Schematic — Kawasaki	7-1
Maintenance	8-1
Maintenance Locator Chart	8-2
Troubleshooting	9-1

GENERAL INFORMATION

Hustler® Service Program

This manual is part of a service package for the Hustler® Raptor® SD mowers. Use of this manual in conjunction with other Hustler® mower and component manuals will provide the information necessary to service and maintain the Hustler® Raptor® SD mower.

This General Service Manual is a service guide for use by Service Technicians. It provides the necessary information needed to perform normal maintenance requirements on these units.

The Parts Manual provides a complete parts listing for the unit. Use this manual when ordering parts.

The Operator's Manual provides fundamental operational information and operational safety that is needed when operating the mower.

The component manuals are furnished by the various manufacturers to be used for the troubleshooting and servicing of their components.

Maintenance Introduction

Regular maintenance is the best prevention for downtime or premature failure. The following pages contain suggested maintenance information and schedules which the operator/mechanic should follow on a routine basis.

Remain alert for unusual noises, they could be signaling a problem. Visually inspect the machine for any abnormal wear or damage. A good time to detect potential problems is while performing scheduled maintenance service. Correcting the problem as quickly as possible is the best insurance.

Clear away heavy build-up of grease, oil and dirt, especially in the engine compartment and under the seat platform areas;

minute dust particles are abrasive to close-tolerance engine and hydraulic assemblies.

Daily inspect mower for grass clippings and wire and string tangles. The underside of the mower deck will collect a build-up of grass clippings and dirt, especially when grass is wet or has high moisture content. This build-up will harden, restricting blade and air movement and will probably show a lesser quality of cut. Therefore it should be removed routinely.

To do this it will be necessary to raise and block the deck, using jack stands or blocks, in the full up position and scrape the build-up from underneath.

Some repairs require the assistance of a trained service mechanic and should not be attempted by unskilled personnel. Consult your Hustler® Turf Equipment service center when assistance is needed.

Information included in this manual was current at the time of printing, but subsequent production changes may cause your machine to vary slightly in detail. Hustler® Turf Equipment reserves the right to redesign and change the machine as deemed necessary, without notification. If a change has been made to your machine which is not reflected in this service manual contact the Customer Service Department at Hustler® Turf Equipment for additional information.



Warranty



Warranty repair must be performed by a Hustler® Turf Equipment Authorized Dealer before warranty credit can be allowed. Work performed by anyone other than an Authorized Dealer will invalidate the warranty claim and warranty credit will not be approved.

SAFETY



This safety alert symbol is used to call attention to a message intended to provide a reasonable degree of **PERSONAL SAFETY** for operators and other persons during the normal operation and servicing of this equipment.

	DANGER	
– denotes immediate hazards which WILL result in severe personal injury or death.		

	WARNING	
– denotes a hazard or unsafe practice which COULD result in severe personal injury or death.		

Safe Servicing Practices

This product is capable of amputating hands and feet and throwing objects. Always follow all safety instructions to avoid serious injury or death.

Understand correct service

- ▲ Be sure you understand a service procedure before you work on the machine.
- ▲ Unauthorized modifications to the machine may impair the function and/or safety and affect machine life.
- ▲ If it is necessary to make checks with the engine running, always use two people - with the operator at the controls, able to see the person doing the checking.

Pre-Operation Precautions

Fuel Handling

- ▲ To avoid personal injury or property damage, use extreme care in handling fuel. Fuel is extremely flammable and the vapors are explosive.
- ▲ Observe usual fuel handling precautions:
 - Do not smoke while refueling. Extinguish all cigarettes, cigars, pipes and other sources of ignition.
 - **Do not remove fuel cap or fill tank with engine running or while engine is hot. Clean up any fuel spills.**
 - Allow engine to cool before storing machine inside a building.
 - Keep fuel away from open flame or spark and store machine away from open flame or spark or pilot light such as on a water heater or appliances.
 - Use extreme care when handling gasoline and other fuels. They are extremely flammable and vapors are explosive. A fire or explosion from fuel can burn you and others and can damage property.

- Refuel outdoors. Never refuel or drain the fuel from the machine indoors.
- Never attempt to start engine when there is a strong odor of gasoline or diesel fuel fumes present. Locate and correct cause.
- Store fuel in an approved container and keep it out of the reach of children. Never buy more than a 30 day supply of fuel.
- Do not fill fuel containers inside a vehicle or on a truck or trailer bed with interior carpets or plastic truck bed liners. Always place fuel containers on the ground away from your vehicle before filling.
- When practical, remove gas or diesel fuel powered equipment from the truck or trailer and refuel the equipment with its wheels on the ground. If this is not possible, then refuel such equipment on the truck or trailer using a portable container and not a fuel dispenser nozzle. If a fuel dispenser nozzle must be used, keep the nozzle in contact with the rim of the fuel tank or container opening at all times until fueling is complete. Do not use a nozzle lock-open device.
- Never use gasoline or diesel fuel for cleaning parts.
- Read and observe safety precautions elsewhere in this manual.
- ▲ Gasoline and diesel fuel is harmful or fatal if swallowed.
 - Long-term exposure to vapors can cause serious injury and illness.
 - Avoid prolonged breathing of vapors.
 - Keep face away from nozzle and gas tank or fuel container opening.
 - Keep fuel away from eyes and skin.
 - If fuel is spilled on clothing, change clothing immediately.

Understand Machine Operation

- ▲ Only qualified and trained personnel should operate the equipment.
- ▲ Carefully read the operator's manual and all manuals furnished with the attachments. Learn the location and purpose of all controls, instruments, indicators and labels.

Wear Protective Clothing

- ▲ Do not operate or service the equipment while wearing sandals, tennis shoes, sneakers, shorts or any type of loose fitting clothing. Long hair, loose clothing or jewelry may get tangled in moving parts. Always wear long pants, safety glasses, ear protection and safety shoes when operating or servicing this machine.
- ▲ Always wear adequate eye protection when servicing the hydraulic system and battery, or when grinding mower blades and removing accumulated debris.
- ▲ Prolonged exposure to loud noise can cause impairment or loss of hearing.
 - Always wear adequate ear protection, such as earplugs, when operating this equipment as prolonged exposure to uncomfortable or loud noises can cause impairment or loss of hearing.

- Do not wear radios or music headphones while operating the machinery. Safe operation requires your full attention.

Operation Precautions

Avoid Fire Hazards

- ▲ **Clean flammable material from machine. Prevent fires by keeping engine compartment, top of deck, exhaust area, battery, hydraulic lines, fuel line, fuel tank and operator's station clean of accumulated trash, grass clippings, and other debris. Always clean up spilled fuel and oil.**

Start Engine Safely

- ▲ Avoid possible injury or death from machine runaway.
- ▲ Do not start engine by shorting across starter terminals.
- ▲ Before you start the engine:
 - Sit on the operator's seat.
 - Move control levers to the neutral/brake position.

Operate Machine Safely

- ▲ Refer to the unit's operator's manual for complete safety information on safe machine operation.
- ▲ Always maintain a safe distance from people and pets when mowing
- ▲ Always be aware of what is behind the machine before backing up.
- ▲ Never leave machine unattended with ignition key in switch, especially with children present.
- ▲ Follow daily and weekly checklists, making sure hoses are tightly secured and bolts are tightened.
- ▲ Always keep engine and machine clean, removing accumulated dirt, trash and other material from machine.
- ▲ Never put hands or feet under any part of the machine while it is running.
- ▲ Never attempt to start engine when there is a strong odor of gasoline fumes present. Locate and correct cause.
- ▲ Keep all safety shields and covers in place, except for servicing.
- ▲ Do not touch hot parts of machine.

General Maintenance Precautions

- ▲ **Repairs or maintenance requiring engine power should be performed by trained maintenance personnel only.**
- ▲ Never run the engine in an enclosed area unless exhaust is vented to the outside. Exhaust gases contain carbon monoxide which is an odorless and deadly poison.
- ▲ Unless specifically required, **DO NOT** have engine running when servicing or making adjustments to mower. Park the machine on level ground. Place steering control levers in the park brake position, disengage deck clutch, lower deck, remove ignition switch key and disconnect negative battery cable before doing any maintenance. Wait for all movement to stop before adjusting, cleaning or repairing. To prevent carbon monoxide poisoning, be sure proper ventilation is available when engine must be operated in an enclosed area.

- ▲ Before working on or under the deck, make certain engine cannot be accidentally started. Shut engine off, remove ignition switch key and disconnect negative battery cable for maximum safety.
- ▲ Except when changing or checking belt, **always** keep belt covers on mower deck for safety as well as cleanliness.
- ▲ Use a stick or similar instrument to clean under the mower making sure that no part of the body, especially arms and hands are under mower.
- ▲ Keep your machine clean and remove any deposits of trash and clippings, which can cause engine fires and hydraulic overheating as well as excessive belt wear. Clean up oil or fuel spillage. Allow machine to cool before storing.
- ▲ Always wear adequate eye protection when servicing the hydraulic system and battery, or when grinding mower blades and removing accumulated debris.
- ▲ Never attempt to make any adjustments or repairs to the mower drive system, mower deck or any attachment while the engine is running or deck clutch is engaged.
- ▲ Exercise caution when releasing spring tension from any of the belt idlers or when working with any of the deck lift components.
- ▲ Never work under the machine or attachment unless it is safely supported with jack stands. Make certain machine is secure when it is raised and placed on the jack stands. The jack stands should not allow the machine to move when the engine is running and the drive wheels are rotating. **Use only certified jack stands.** Use only appropriate jack stands, with a minimum weight rating of 2000 pounds to block the unit up. Use in pairs only. Follow the instructions supplied with the vehicle stands.
- ▲ Keep nuts and bolts tight, especially the blade attachment bolts. Keep equipment in good working condition.
- ▲ Never tamper with safety devices. Check their proper operation regularly.
- ▲ Exercise caution when working under the deck as the mower blades are extremely sharp. Wrap the blade(s) or wear gloves and use extra caution when servicing them.
- ▲ Use only genuine Hustler® replacement parts to ensure that original standards are maintained.

Maintenance Precautions

Avoid Fire Hazards

- ▲ Be prepared if an accident or fire should occur. Know where the first aid kit and the fire extinguishers are located and how to use them.
- ▲ Provide adequate ventilation when charging batteries.
- ▲ Do not smoke near battery.
- ▲ Never check fuel level with an open flame.
- ▲ Never use an open flame to look for leaks anywhere on the equipment.
- ▲ Never use an open flame as light anywhere on or around the equipment.
- ▲ When preparing engine for storage, remember that fuel stabilizer is volatile and therefore dangerous. Seal and tape openings after adding the inhibitor. Keep container tightly closed when not in use.

- ▲ Inspect electrical wiring for worn or frayed insulation. Install new wiring if wires are damaged.

Prepare For Emergencies

- ▲ Be prepared if a fire starts.
- ▲ Keep a first aid kit and fire extinguishers available.
- ▲ Keep emergency numbers for doctor, ambulance service, hospital, and fire department near the telephone.

Prevent Battery Explosions

- ▲ Battery posts, terminals, and related accessories contain lead and lead compounds, chemicals known to the State of California to cause cancer and reproductive harm. Wash hands after handling.
- ▲ Charge batteries in an open well-ventilated area, away from sparks and flames. Unplug charger before connecting or disconnecting from battery. Wear protective clothing and use insulated tools.
- ▲ Avoid skin and clothing contact with battery acid.
 - Always wear eye protection when checking the battery, acid can cause serious injury to skin and eyes. If contact occurs, flush area with clean water and call physician immediately. Acid will also damage clothing.
 - Do not drink the battery electrolyte.
 - Do not allow open flame near the battery when charging.
 - Hydrogen gas forms inside the battery. This gas is both toxic and flammable and may cause an explosion if exposed to flame. Always **disconnect** the negative (black) battery cable(s) before disconnecting the positive (red) cable(s). Always **connect** the positive (red) battery cable(s) before connecting the negative (black) cable(s).
 - Do not overfill battery.
 - Electrolyte may overflow and damage paint, wiring or structure. When cleaning the battery, use soap and water. Be careful not to get soap and water into the battery. Clean the battery terminals with a solution of four parts water and one part baking soda when they become corroded.

- ▲ Shorts caused by battery terminals or metal tools touching metal mower components can cause sparks. Sparks can cause a battery gas explosion which will result in personal injury.

- Prevent the battery terminals from touching any metal mower parts when removing or installing the battery.
- Do not allow metal tools to short between the battery terminals and metal mower parts.

- ▲ Incorrect battery cable routing could cause damage to the mower and battery cables. This can cause sparks which can cause a battery gas explosion which will result in personal injury. Always **disconnect** the negative (black) battery cable(s) before disconnecting the positive (red) cable(s). Always **connect** the positive (red) battery cable(s) before connecting the negative (black) cable(s).

Avoid Acid Burns

- ▲ Sulfuric acid in battery electrolyte is poisonous. It is strong enough to burn skin, eat holes in clothing and cause blindness if splashed in eyes.

Avoid the hazard by:

- Filling batteries in a well-ventilated area.
- Wearing eye protection and rubber gloves.
- Avoiding breathing fumes when electrolyte is added.
- Avoiding spilling or dripped electrolyte.

If you spill acid on yourself:

- Flush your skin with water.
- Apply baking soda or lime to help neutralize the acid.
- Flush your eyes with water for 10-15 minutes. Get medical attention immediately.

If acid is swallowed:

- Drink large amounts of water or milk.
- Then drink milk of magnesia, beaten eggs or vegetable oil.
- Get medical attention immediately.

TORQUE

Standard Torques

The following chart lists the standard torque values for the threaded fasteners found in this manual. Torque all cap screws, nuts and set screws to these values unless a different torque is shown in the Special Torques section.



SIZE	FT-LBS	N-M	SIZE	FT-LBS	N-M
#10	32.4 IN.-LBS.	3.6	M3	12 IN.-LBS.	1.3
.250	98.4 IN.-LBS.	11.1	M4	26.4 IN.-LBS.	3
.312	204 IN.-LBS.	23	M5	54 IN.-LBS.	6.1
.375	30	40	M6	92.4 IN.-LBS.	10.4
.438	48	65	M8	222 IN.-LBS.	25
.500	73	99	M10	37	50
.562	105	143	M12	64	87
.625	145	200	M14	103	140
.750	260	350	M16	160	215
.875	420	565	M20	320	435

Special Torques

DESCRIPTION	FT-LBS	N-M
Wheel (lug) nuts ¹	70	95
Blade spindle bolt top	73	99
Blade spindle bolt bottom	118	160
Electric clutch mounting bolt ³	47	63.7
Front wheel axle bolt	Tighten the nut, then back it off until the wheel spins freely.	
Transaxle hub nut	200	271
Transaxle pump pulley nut	50	67.8
Engine torques ²	N/A	N/A

NOTE:

- Lug nuts only** – It is recommended that these be checked after the first 2 hours of operation and every 50 hours and following removal for repair or replacement.
- Engine torque values** – Refer to the respective engine owner's manual.
- If clutch mounting bolt is loosened or removed, **do not re-use**. Replace with a new bolt. Use only hand tools to install this fastener.

	WARNING	
Particular attention must be given to tightening the drive wheel lug nuts and blade spindle bolts. Failure to correctly torque these items may result in the loss of a wheel or blade, which can cause serious damage or personal injury.		

POWER UNIT MAINTENANCE

Steering Adjustments

Steering control lever neutral adjustment

The mower's steering has been factory adjusted to eliminate creeping when the steering control levers are in the neutral position. However, should the mower begin to creep, the steering control lever linkage can be adjusted.

Before considering any adjustment, check the tire air pressure. Unequal tire pressure will cause the mower to drift to one side. Refer to tire pressure information in the *Tire* section for detailed information.

NOTE: Proper park brake adjustment must be completed before the steering control lever neutral adjustment can be done. Refer to the *Park Brake Spring Adjustment* section for detailed information.

Fine adjustment to the unit's steering is made with the transmission's control rod.

Neutral is properly adjusted when the steering control levers are in the park brake position and the transmissions do not "whine".

If this occurs, the steering control linkage may be adjusted as follows:



WARNING



This procedure will require that the unit to be raised and blocked up off of the ground. It is necessary for the wheels to rotate without coming in contact with the floor or any object that would permit the unit to propel itself. Stay clear and exercise caution when rotating wheels to prevent injury. Use only appropriate vehicle stands, with a minimum weight rating of 2000 pounds to block the unit up. Use in pairs only. Follow the instructions supplied with the vehicle stands.



WARNING



Keep hands, hair, clothing, etc., clear of the pulleys on top of the transmissions. Exercise extreme caution.



WARNING



Untrained maintenance personnel should never attempt to make any adjustments or repairs to the mower's drive system while the engine is running. **The following procedures should be performed by trained maintenance personnel only.**

1. Shut engine off, place steering control levers in the park brake position, disengage deck clutch, remove ignition switch key and disconnect negative battery cable before doing any adjustments.

2. Raise the rear of the mower and block with certified jack stands. Remove the rear wheels.
3. Chock the front tires.
4. Make sure both steering control levers are in the park brake position. Figure 4-1



Figure 4-1

5. Loosen the nuts adjacent to the steering bushing. Figure 4-2

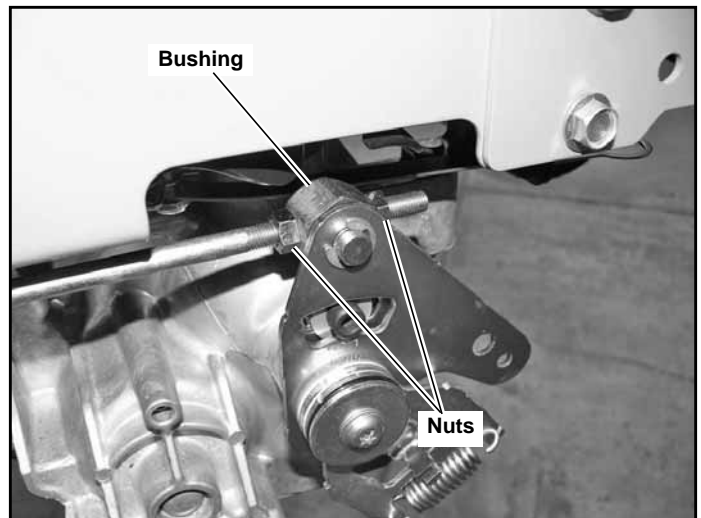

Figure 4-2

6. Place a clamp on the transmission pump arm as shown in Figure 4-3.
7. Tighten the nuts against steering bushing (Figure 4-4). Verify that the pump arms are still in the neutral position
8. Move the steering control levers out of the park brake position and push fully forward, verify that the pump arm does not bottom out against the stop on the transmission. Move the levers to the full reverse position and release. Verify that the levers return near to the neutral position.
9. The steering control levers should be adjusted so that they align vertically with each other when in the neutral position (Figure 4-5). Space between ends of steering control handles to be $.50'' \pm .25''$. Figure 4-5
10. Check to make sure all tools or obstructions are removed from under the mower.

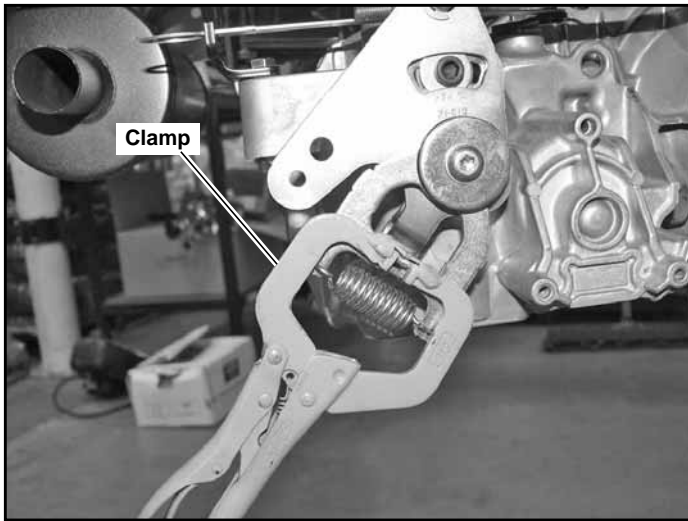

Figure 4-3

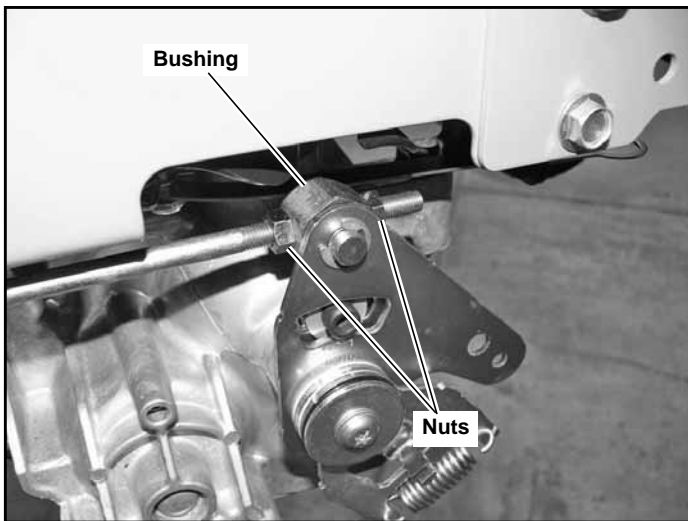

Figure 4-4

11. Re-install the rear wheels. Torque lug nuts to 70 ft.-lbs. (95 N-M)
12. Raise the rear of the mower and remove the jack stands. Lower the mower.
13. Re-attach the negative battery cable.
14. Close the seat platform

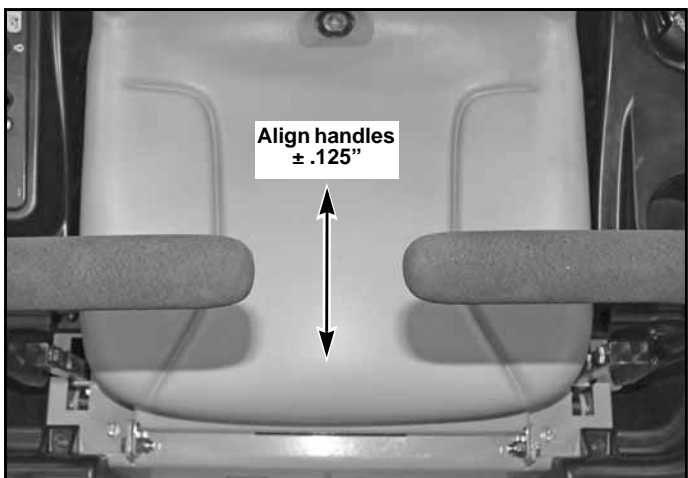

Figure 4-5

Control lever stops adjustment.

! **WARNING** !

Keep hands, hair, clothing, etc., clear of the rotating drive wheels/hubs during this process. Exercise extreme caution.

The steering control lever stops may be adjusted to help drive straight when the steering control levers are pushed forward against the stops.

1. Raise the rear of the mower and block with certified jack stands.
2. Chock the front tires.
3. Make sure both steering control levers are in the park brake position. Figure 4-6 .



Figure 4-6

4. Raise the seat platform and disconnect the mower harness from the seat switch. Bypass the seat switch by connecting the two mower harness female spades together.. Figure 4-7

! **WARNING** !

Do not operate (drive) the mower without plugging the mower's wiring harness into the seat switch. This switch is an important part of the safety start interlock system. Serious injury can result if the seat switch is not plugged into the mower's wiring harness.

5. Start the engine and move both steering control levers forward against the stops in the steering cover.
6. Determine if the drive wheels are rotating equally or if one is faster than the other. If the wheels are not the same speed, proceed to the next step.
7. Shut engine off and place the steering control levers in the park brake position
8. Loosen the cap screw under the seat platform on the side which is rotating too fast. Tighten the cap screw on the top of the steering cover to adjust the drive straight bracket up to stop the steering control lever sooner. Repeat this procedure until both drive wheels rotate at the same speed. Figure 4-8

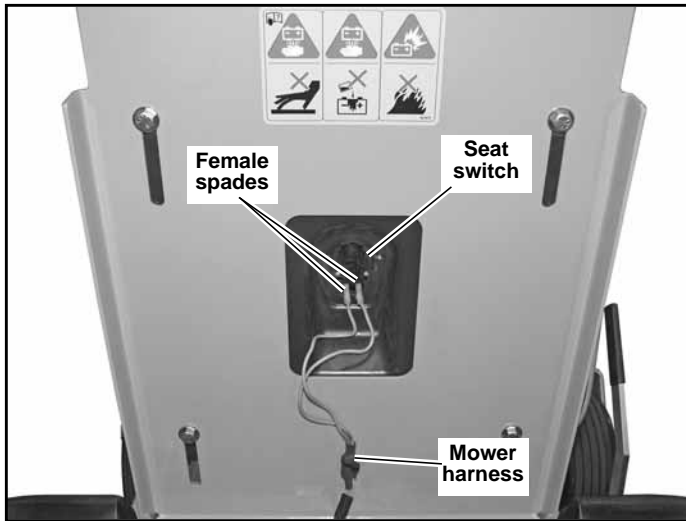

Figure 4-7

9. Tighten the cap screws under the seat platform on both sides to lock the drive straight brackets in place. Snug the cap screws on the top of the steering cover so they don't move during operation.
10. **IMPORTANT:** With the engine off, disconnect the two female spade connectors from each other (from step #4) and reconnect them to the seat switch. This must be completed so that the safety circuit is functioning properly. Figure 4-7
11. Lower the seat platform and secure in place.

! **WARNING** !

Do not operate the mower without plugging the mower's wiring harness into the seat switch. This switch is an important part of the safety start interlock system. Serious injury can result if the seat switch is not plugged into the mower's wiring harness.

! **WARNING** !

Never operate the mower with a non-functioning seat switch. Always reconnect the seat switch to the mower harness.

Park Brake Spring Adjustment

Occasionally check the park brake spring adjustment using the following method:

1. Shut engine off, place steering control levers in the park brake position, disengage deck clutch, remove ignition switch key and disconnect negative battery cable before doing any adjustments.
2. Make sure steering control levers are in the park brake position.
3. Adjust the nylock nut on the end of the brake rod so that 0.25" of thread is showing. Repeat for other side. Figure 4-9

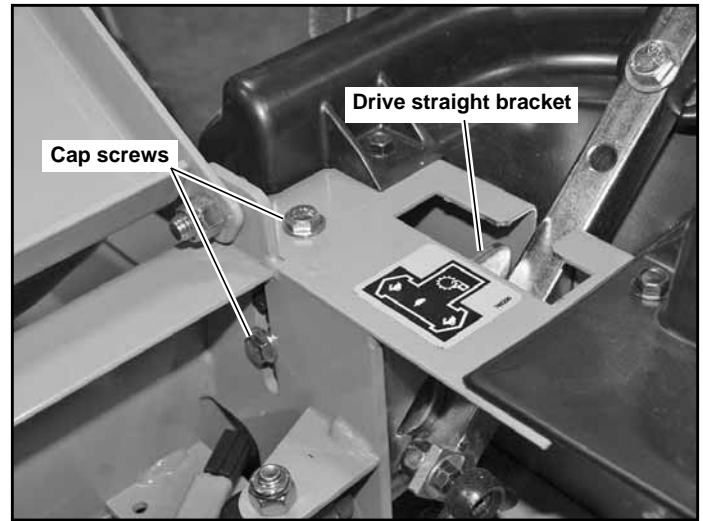

Figure 4-8

4. Reconnect the negative battery cable.
5. Close seat platform and re-install seat platform hardware.

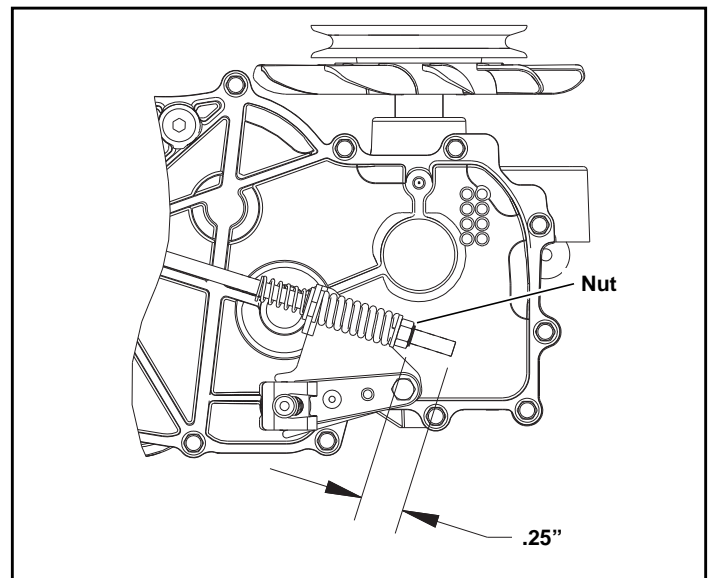

Figure 4-9

Transaxle Drive Belt

Inspect belts frequently for wear and serviceability. Replace a belt that shows signs of severe cuts, tears, separation, weather checking and cracking, or burns caused by slipping. Slight raveling of belt covering does not indicate failure; trim ravelings with a sharp knife.

Inspect the belt pulley grooves and flanges for wear. A new belt, or one in good condition, should never run against the bottom of the groove. Replace the pulley when this is the case, otherwise, the belt will lose power and slip excessively.

Never pry a belt to get it on a pulley as this will cut or damage the fibers of the belt covering.

Keep oil and grease away from belts, and never use belt dressings. Any of these will destroy the belt composition in a very short time.

Belt Adjustment

The transaxle drive belt tension remains constant by means of

a tension idler and spring. There is no tension adjustment of this belt. Figure 4-10

NOTE: Inspect the belt every month and replace as needed. Replace the belt every two (2) years.

WARNING

If the transaxle belt fails, loss of control will occur especially when operating on a slope. If you lose steering control while operating the machine, place the steering control levers in the park brake position immediately. Inspect the machine and involve your dealer to resolve the problem.

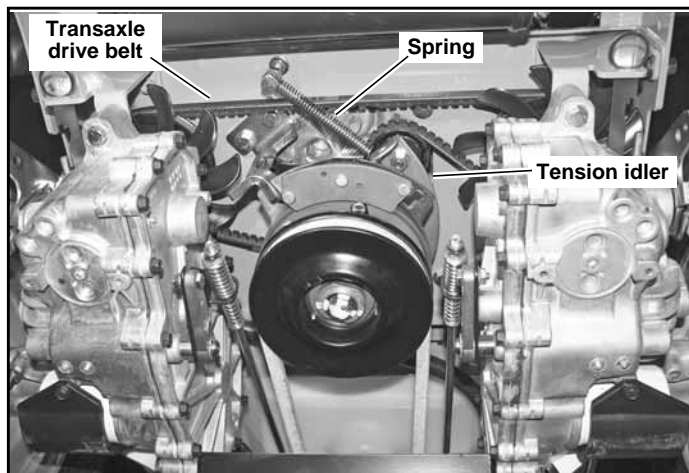

Figure 4-10

Belt replacement

WARNING

This procedure will require that the mower to be raised and blocked up off of the ground. Use only appropriate vehicle stands, with a minimum weight rating of 2000 pounds to block the unit up. Use in pairs only. Follow the instructions supplied with the vehicle stands.

WARNING

Allow the engine and muffler to cool before proceeding with the following procedure.

1. Park the mower on a flat surface and stop the engine. Make sure deck clutch switch is in the down (OFF) position. Remove ignition key. Place the steering control levers in the park brake position. Make sure the blades are stopped before leaving seat. Disconnect the negative battery cable.
2. Lower the deck to the lowest setting.
3. Remove the deck covers. Figure 4-11
4. Using a tension spring hook (Hustler part number 604462) disconnect the tension idler spring from the

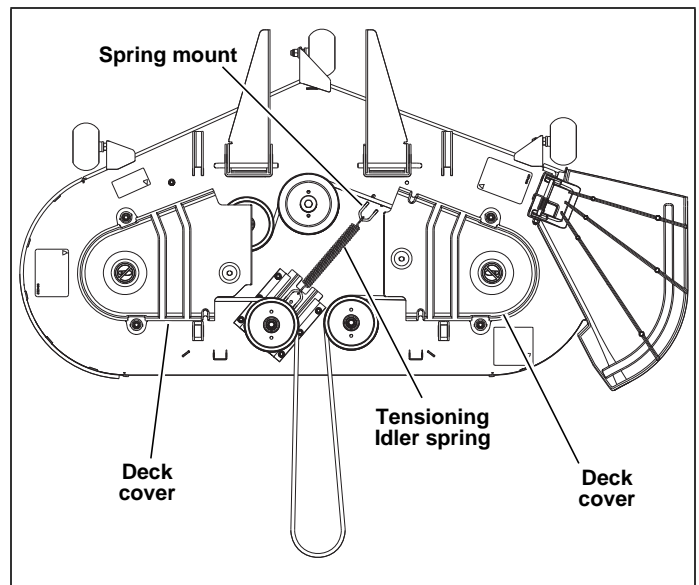

Figure 4-11

spring mount to release tension from the deck drive belt. Figure 4-12

NOTE: The spring and spring mount will become loose and can become misplaced. Set these aside after removal for easier access upon re-assembly.

WARNING

Exercise caution when releasing spring tension from the belt idler.

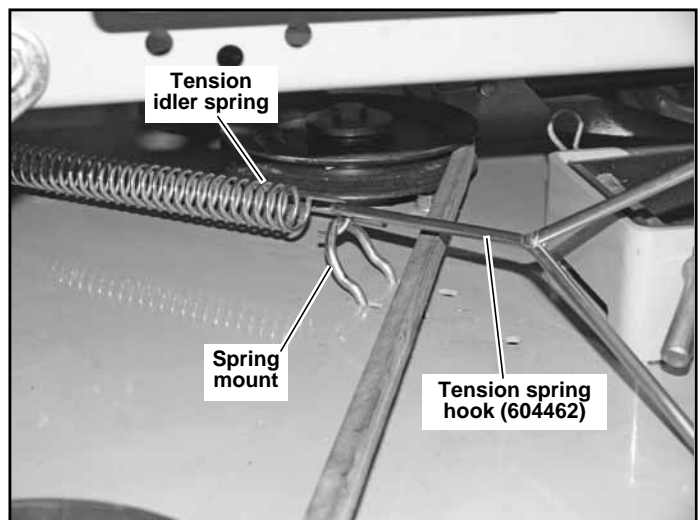

Figure 4-12

5. Raise the rear of the mower and block with certified jack stands.
6. Remove the deck drive belt from the electric clutch pulley located on the engine shaft. Figure 4-13
NOTE: Do not remove the deck drive belt from the deck spindle pulleys. It will only need to be removed from the electric clutch pulley at the rear of the mower.
7. Locate the tension idler spring. Securely clamp locking pliers onto the spring at the end located next to the idler arm. Figure 4-10

8. Release the transaxle drive belt tension, using the locking pliers, to remove the tension spring from the idler arm. Swing the idler arm out of the way. Figure 4-13
9. Remove the transaxle drive belt from the transaxle drive pulleys and the engine pulley. Figure 4-13 & Figure 4-14

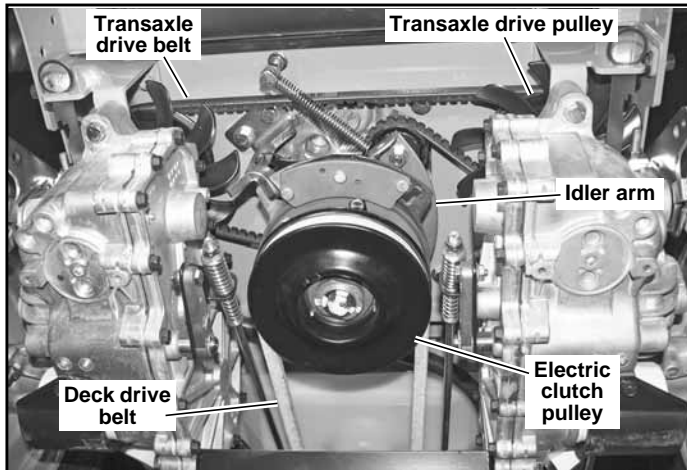

Figure 4-13

10. Replace the transaxle drive belt and route it around the engine pulley and the transaxle drive pulleys. Figure 4-14

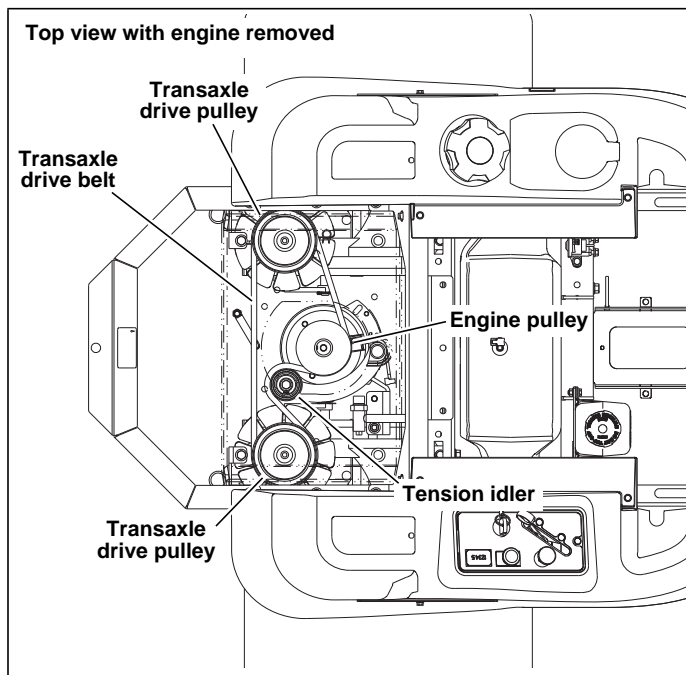
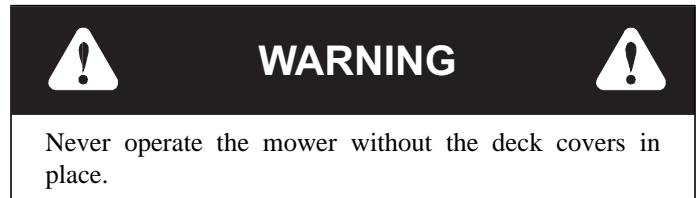

Figure 4-14

11. Make sure the transaxle drive belt is routed correctly around the tension idler before attaching the tension spring. Using the locking pliers, re-attach the tension spring to the idler arm to re-tension the transaxle drive belt. Remove the locking pliers from the tension spring. Figure 4-14
12. Reroute the deck drive belt around the electric clutch pulley. Make certain the belt is routed properly around the spindle pulleys and stationary idler pulley(s). Using the tension spring hook (604462), re-tension the deck

drive belt by pulling on the deck belt idler spring and hooking it in the spring mount on the deck. Figure 4-12, Figure 4-13, & Figure 4-15

13. Re-install the deck covers.



14. Raise the rear of the mower and remove the jack stands.
15. Lower the mower.
16. Re-attach the negative battery cable.

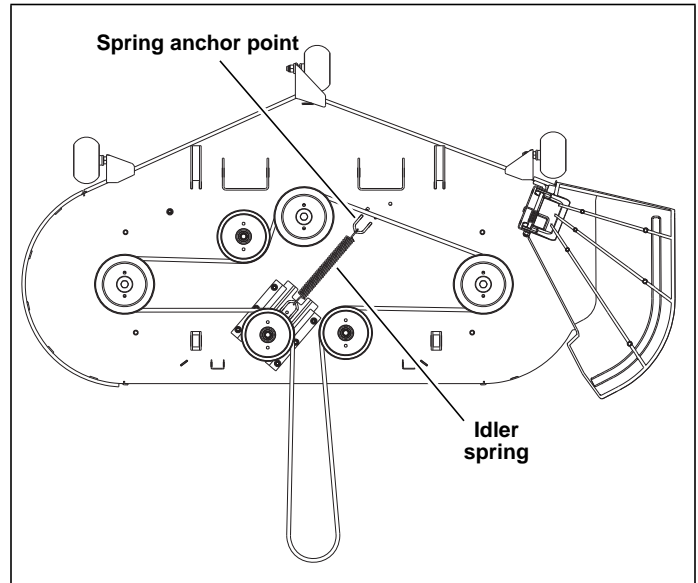

Figure 4-15

Hydraulic System

This mower is equipped with two integrated hydrostatic transmissions. Figure 4-16

IMPORTANT: Never use hydraulic or automatic transmission fluid in this system; use only motor oil as specified. Remember, dirt is the primary enemy of any hydraulic system.

The hydraulic expansion tank is located in front of the engine and under the operator's platform. Figure 4-16

Check oil level in hydraulic system after every 50 hours of operation or weekly, whichever occurs first. Check more often if system appears to be leaking or otherwise malfunctioning.

Fluid level should be at the "Full Cold" line on the expansion tank. Use only SAE 20W50 SL/SM service motor oil.

Initial system oil and filter change **must** be after the first 75 hours of use or 1 year whichever comes first. Thereafter, replace filter and oil in each transmission every 2 years or 200 hours, whichever comes first. **NOTE:** The filter guard must be removed to access filter.

Each transmission's filter is located per Figure 4-17. A standard oil filter wrench is used to change filter, threads are right

handed. Use a Hustler® approved filter element only.

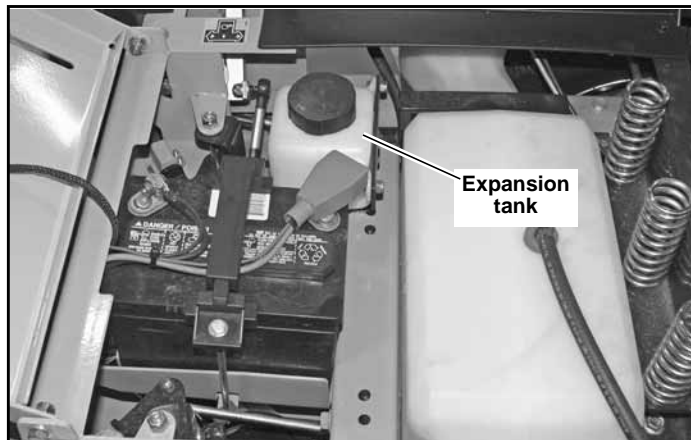
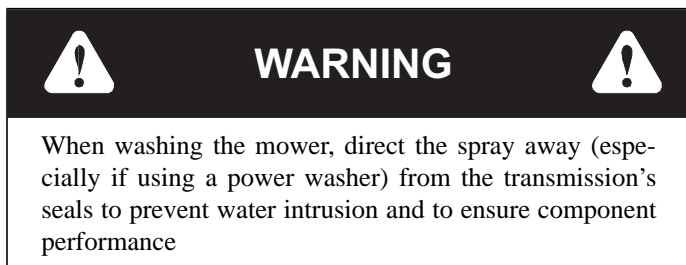

Figure 4-16

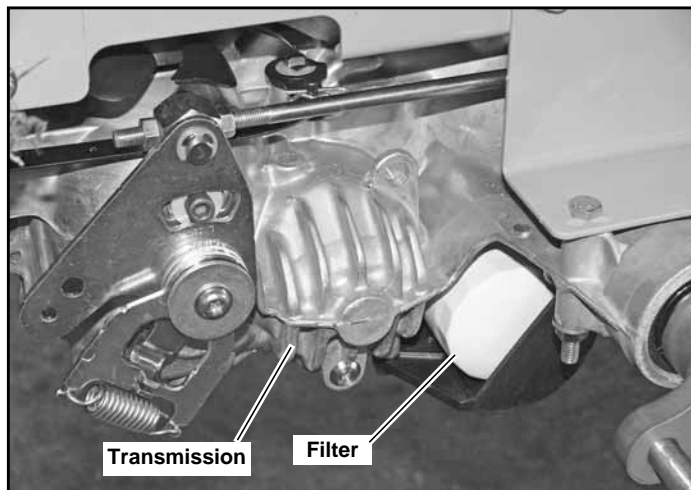

Figure 4-17

Fluid changing procedure

1. Park the unit on a level surface. Place control levers in the park brake position, disengage deck clutch, remove ignition switch key and disconnect negative battery cable.
2. Remove the three 1/4" filter guard screws and filter guard. Clean any loose debris from around the filter. Figure 4-18
3. Place an oil drain pan beneath the oil filter and remove the oil filter from the transaxle.
4. After the oil has been drained, wipe the filter base surface off and apply a film of new oil to the gasket of the new replacement filter.
5. Install the new filter by hand, turn 3/4 to one full turn after the filter gasket contacts the filter base surface.
6. Re-install the filter guard with three 1/4" screws. Torque the screws to 65 in.-lbs. each. Figure 4-18

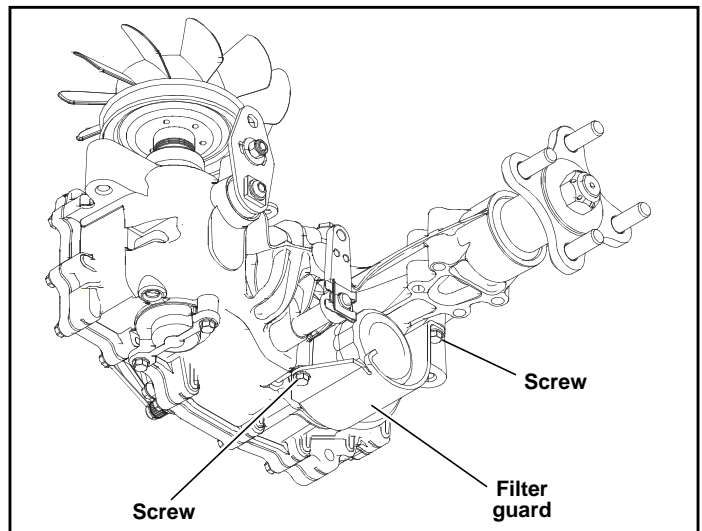

Figure 4-18

7. Repeat steps 2 - 6 for the opposite side transaxle.
8. Drain oil filters of all free flowing oil prior to disposal. Place used oil in appropriate containers.
9. **IMPORTANT:** Remove the top port plug from both transaxles prior to filling with oil. This will allow the transaxles to vent during oil fill. Figure 4-19
10. Remove the cap from the transaxle's expansion tank.
11. Fill with 20W50 motor oil until oil just appears at the bottom of each transaxles top port (approximately 2 qts. per transaxle). Install the top port plug into each transaxle. Torque plugs to 180 in. lbs. Clean up any oil that leaked from the ports. Figure 4-19
12. Continue to fill the transaxles through the expansion tank until the "Full Cold" line is reached on the expansion tank.
13. Re-install the expansion tank cap by hand. Be careful not to overtighten.
14. Proceed to the purge procedure.

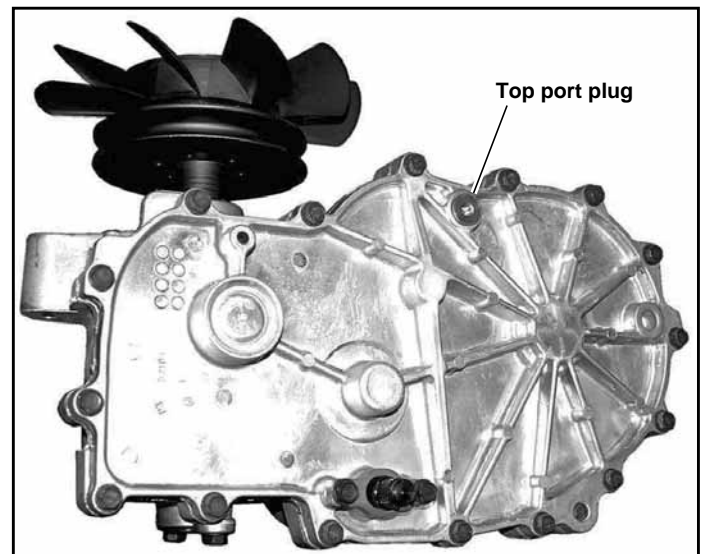

Figure 4-19

IMPORTANT: Purging procedures must be followed after changing the oil and filter. Refer to *Purging Procedure* section for detailed information.



WARNING



When washing the mower, direct the spray away (especially if using a power washer) from the transaxle's seals to prevent water intrusion and to ensure component performance.

Purging procedure

Due to the affects air has on efficiency in hydrostatic drive applications, it is critical that it is purged from the system.

Air creates inefficiency because its compression and expansion rate is higher than that of the oil approved for use in hydrostatic drive systems.

These purge procedures should be implemented any time a hydrostatic system has been opened to facilitate maintenance or the oil has been changed.

The resulting symptoms in hydrostatic systems may be:

1. Noisy operation.
2. Lack of power or drive after short term operation.
3. High operation temperature and excessive expansion of oil.

Before starting, make sure the transaxle is at the proper oil level. If it is not, fill to the specifications outlined in this manual.

The following procedures are best performed with the vehicle drive wheels off the ground. Then repeated under normal operating conditions. If this is not possible, then the procedure should be performed in an open area free of any objects or bystanders.

1. Raise and block the mower up so the drive wheels are off of the floor.



WARNING



Never work under the machine or attachment unless it is safely supported with jack stands.

Make certain machine is secure when it is raised and placed on the jack stands. The jack stands should not allow the machine to move when the engine is running and the drive wheels are rotating. **Use only certified jack stands.** Use only appropriate jack stands, with a minimum weight rating of 2000 pounds to block the unit up. Use in pairs only. Follow the instructions supplied with the vehicle stands.

2. Position the control lever in the neutral position. Disengage the deck clutch switch. Figure 4-20
3. With the bypass valve open and the engine running, slowly move the directional control in both forward and reverse directions (5 or 6 times). Figure 4-21
4. With the bypass valve closed and the engine running, slowly move the control lever in both forward and reverse directions (5 or 6 times). Check the oil level, and add oil as required after stopping the engine.

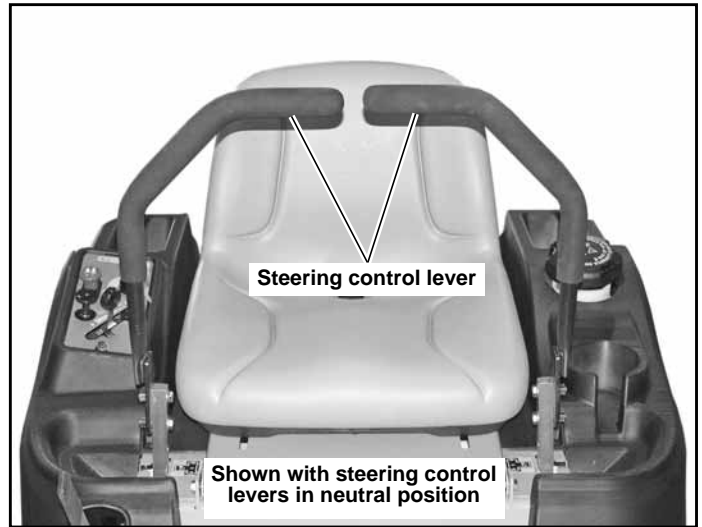

Figure 4-20

5. It may be necessary to repeat Steps 3 and 4 until all the air is completely purged from the system. When the transaxle operates at normal noise levels and moves smoothly forward and reverse at normal speeds, then the transaxle is considered purged.

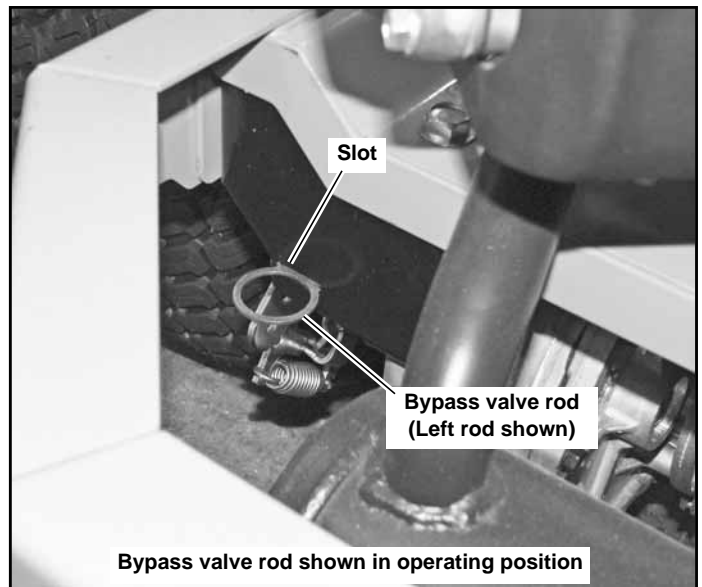

Figure 4-21

Tires

It is important for level mowing that the tires have the same amount of air pressure. The recommended pressures are:

Drive wheels	8-12 psi (55-83 KPa)
Front wheels	8-12 psi (55-83 KPa)

If you wish to use non-pneumatic tires on your Hustler® mower the tires must be an approved tire purchased from Hustler® Turf Equipment. Warranty claims will be denied on any mower equipped with unapproved non-pneumatic tires.

ENGINE MAINTENANCE

General Engine Maintenance

Detailed instructions and recommendations for break-in and regular maintenance are specified in the *Engine Owner's Manual*. Please refer to this manual for engine servicing, lubricating oil levels with quality and viscosity recommendations, bolt torques, etc. The engine warranty is backed by the manufacturer. Special attention should be paid to applicable data which will not be duplicated here.

Engine Oil and Filter



WARNING



If the engine has been running and is up to operating temperature, allow the engine to cool before changing the oil. Engine and engine oil will be very hot, so be very careful when changing oil and wear the appropriate protective gear to avoid being burned or exposed to engine oil.

Check engine oil daily and after every 4 hours of operation. Mower must be on a level surface when checking oil. Refer to engine manual and maintenance schedule for oil recommendation and capacities.

Change the engine oil and filter after the first 5 hours of operation and then per the engine manufacturer's recommendations after that. If mower is being operated in extremely dirty conditions, then it is recommended oil be changed more frequently.

IMPORTANT: After the new oil filter has been installed, clean up any oil which may have spilled onto the engine plate, muffler, and heat shield.

Draining the engine oil :

1. Locate the oil drain valve on the lower right side of the engine.
2. Locate the oil drain hose that was supplied with the machine. Be sure to clean and clear it of debris that might block the flow of the engine oil. Figure 5-1
3. Attach one end of the hose onto the oil drain valve nipple. Make sure the hose is pushed all the way onto the valve.
4. Position the loose end of the hose forward and down in front of the right side transmission so that it can drain into a suitable oil drain container.
5. With the hose in position, use a 10 mm wrench or socket and open the valve approximately 4 turns in the counterclockwise direction. Allow 10 minutes for engine oil to adequately drain.
6. After oil is drained, close the valve by turning it in the clockwise direction until it is fully closed.
7. Once the valve is closed, carefully remove the oil drain hose and clean up any spilled oil.

IMPORTANT: All oil drips or spills **must** be cleaned off of the exhaust system before operating the machine.

8. Clean the oil drain hose and store it appropriately. Figure 5-1

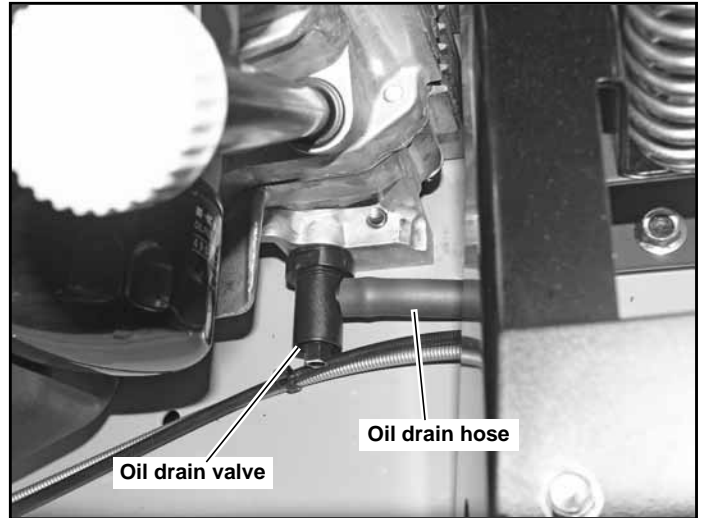

Figure 5-1

Engine Air Filter

Perform engine air filter maintenance per the *Maintenance Schedule* shown elsewhere in this manual.

Carbon canister

Some Hustler® Raptor® SD mowers will have a carbon canister incorporated into the fuel system. Figure 5-2

This is a mandatory feature that is required on all mowers using gasoline engines that are put into operation in California.

These canisters should be replaced every 5 years or if they become damaged.

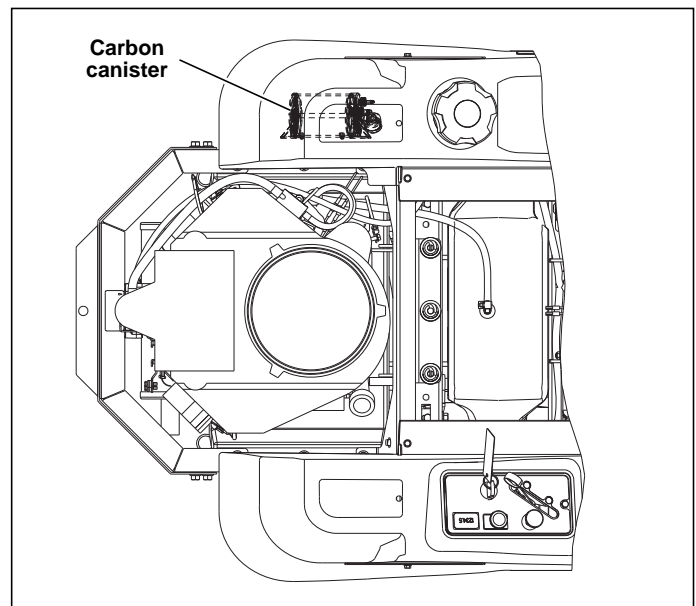

Figure 5-2

Fuel evaporation system filter

All Hustler® Raptor® SD mowers have a fuel evaporation system filter. This filter must be checked and replaced every 100 hours or annually whichever comes first. Figure 5-3 & Figure 5-4

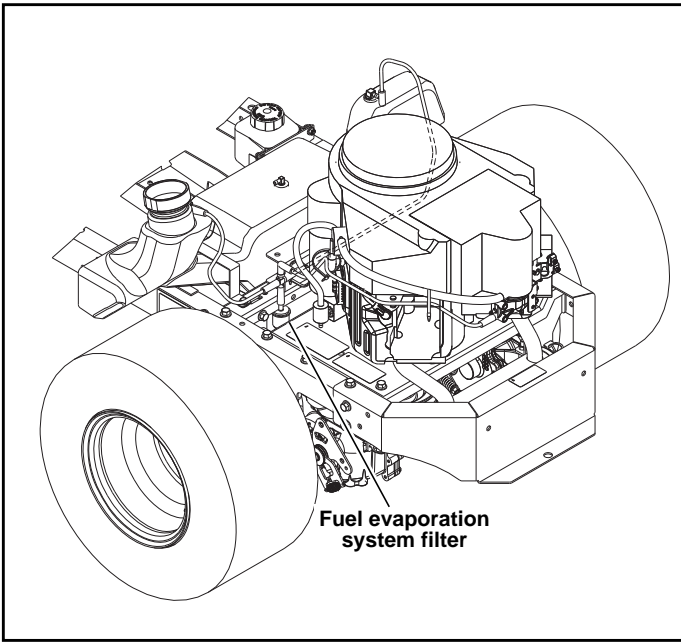

Figure 5-3

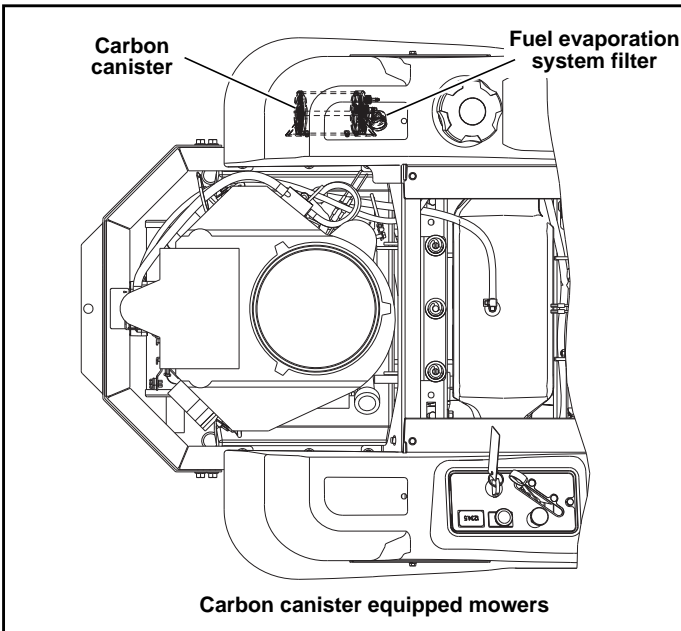

Figure 5-4

Engine RPM Settings

The engine rpm's are set at the factory for maximum mowing efficiency. Occasionally it may be necessary to check and adjust the settings. The idle speeds should be set as follows:

FR651 / FR691 / FR730	
ENGINE SPEED	
MODEL NO. ENDING WITH:	HIGH IDLE
MODEL NO. WITHOUT EXTENSION MODEL NO. WITH US EXTENSION MODEL NO. WITH EX EXTENSION	3600 ± 50 RPM

NOTE: Model numbers may or may not end with an extension after the number. There are several different extensions that may be shown; i.e. EX or CE.

Example: 922222 (no extension)
922222 EX
922222 CE
922222 US

DECK ADJUSTMENTS

Deck Leveling

1. Park the mower on a hard, flat surface.
2. Check tire pressures (8 – 12 psi) to make certain the tires are properly inflated before starting to level deck.



WARNING



Stop engine. Make sure deck clutch switch is in the down (OFF) position. Remove ignition key. Place steering control levers in the park brake position. Make sure blades are stopped before leaving seat.

3. Raise the deck and lock it in the transport position using the transport lever.
4. Insert four (4) 3.00" blocks under the deck at the locations shown.

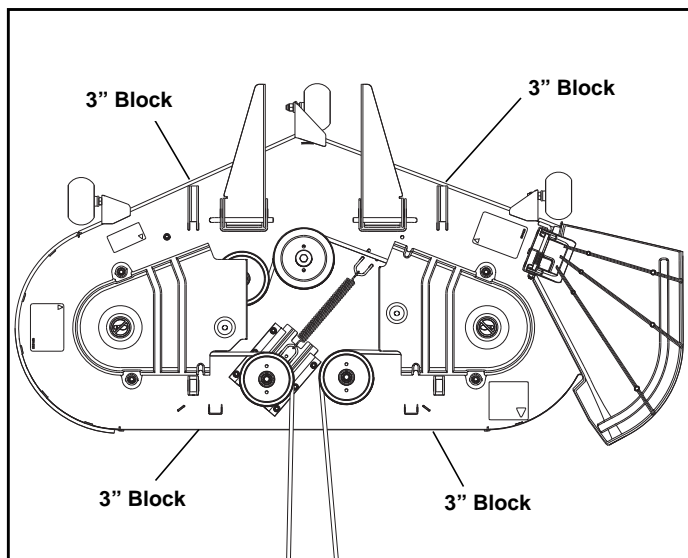

Figure 6-1

5. Lower the deck and place the deck cutting height indicator pin in the "H" (3.25") position. Figure 6-2
6. Loosen the four (4) deck leveling nuts until all of the linkage rods are loose and the deck is sitting on the four (4) 3.00" blocks. The deck **must** be resting on the four (4) 3.00" blocks. Figure 6-2
7. Adjust one (1) of the deck leveling nuts until the deck

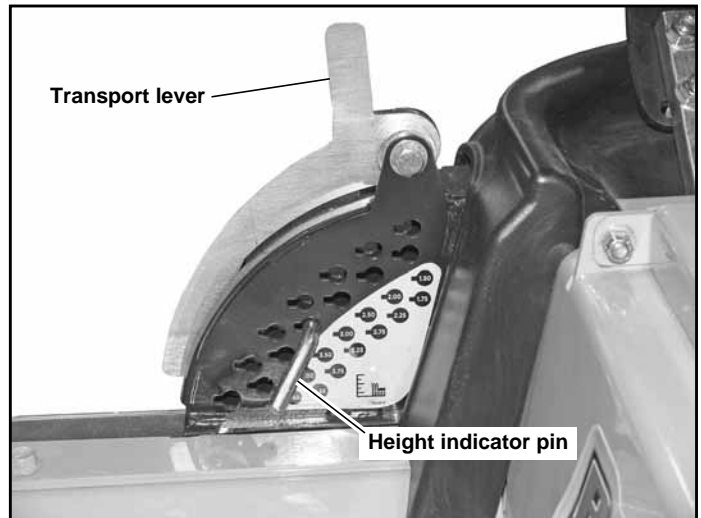

Figure 6-2

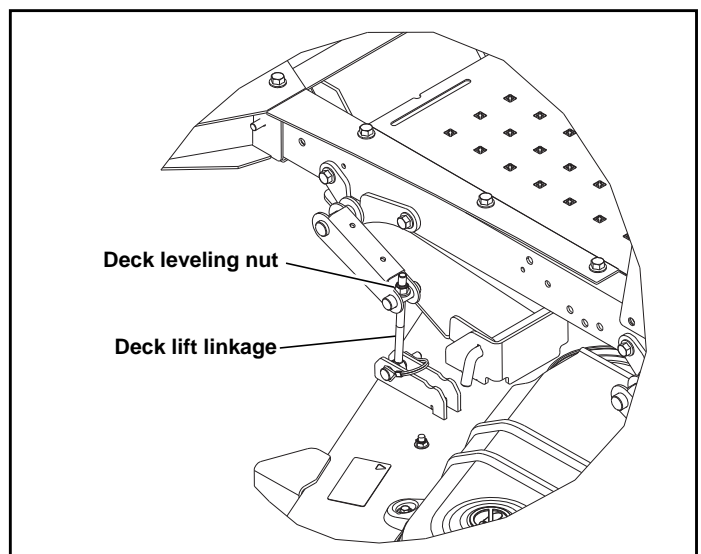

Figure 6-3

begins to lift off of the block. You should be able to slide the block out from under the deck without feeling any resistance. Figure 6-3

IMPORTANT: Raise the deck just enough so that the block can be moved without any resistance from the deck. Repeat at the other three (3) deck leveling positions.

Blades

Mower blade maintenance

Refer to the *Mower blade replacement* section for blade removal and installation.

Check the mower blades daily as they are the key to power efficiency and well groomed turf. Keep the blades sharp. A dull blade will tear rather than cut the grass, leaving a brown ragged top on the grass within a few hours. A dull blade also requires more power from the engine.

Replace any blade which is bent, cracked or broken.

WARNING

Never attempt to straighten a bent blade by heating, or weld a cracked or broken blade as the blade may break and cause serious injury. Replace worn or damaged blades.

WARNING

Never work with blades while engine is running or deck clutch switch is engaged (on). Always place deck clutch switch in the **disengaged** position, place steering control levers in the park brake position and turn engine off and disconnect negative battery cable. Block up mower when you **must** work under it. Wear gloves when handling blades. **Always check for blade damage** if mower strikes a rock, branch or other foreign object during mowing!

WARNING

Always wear adequate eye protection when grinding mower blades.

WARNING

Mower blades are sharp and can cut. Wrap the blade(s) or wear gloves and use extra caution when servicing them.

Sharpen the blades on a grinder following pattern as shown (Figure 6-4). Touch-up sharpening can be done with a file

Check the blades for balance following grinding. A commercial balancing tool is available through most hardware supply stores, or balancing can be done by placing the blade on an inverted line punch or 5/8" bolt. Blade should not lean or tilt. Spin the blade slowly, blade should not wobble. If blade is out of balance, true it up before reinstalling.

Lay the blade on a flat surface and check for distortion (Figure 6-5 & Figure 6-6). Replace any distorted blade.

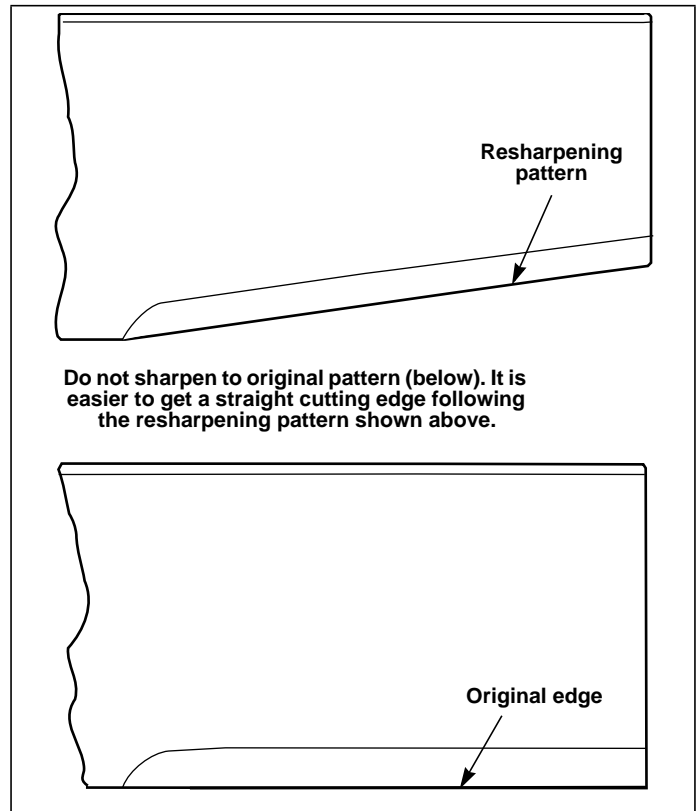

Figure 6-4

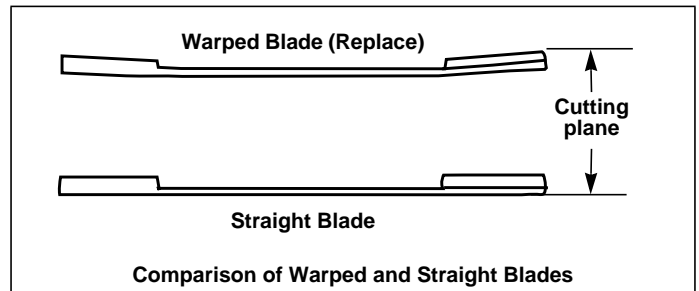

Figure 6-5

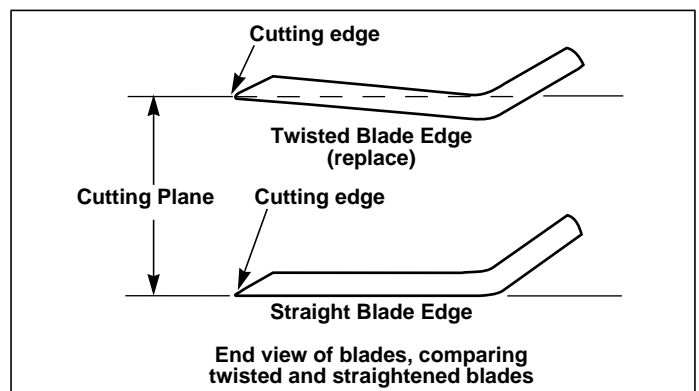

Figure 6-6

Mower blade replacement

WARNING

This procedure will require that the mower to be raised and blocked up off of the ground. Use only appropriate vehicle stands, with a minimum weight rating of 2000 pounds to block the unit up. Use in pairs only. Follow the instructions supplied with the vehicle stands.

1. Park the mower on a flat surface and stop the engine. Make sure deck clutch switch is in the down (OFF) position. Remove ignition key. Place the steering control levers in the park brake position. Make sure the blades are stopped before leaving seat. Disconnect the negative battery cable.
2. Raise the front of the unit and block with certified jack stands. This allows easier access to the blades under the deck.
3. Install a blade lock tool (Hustler® part number 381442) over the two blades to prevent them from rotating.

DANGER

Never work with blades while engine is running or deck clutch is engaged. Always place deck clutch in the disengaged position, engage control levers in the park brake position and turn engine off. Block up mower when you must work under it. Wear gloves when handling blades. Always check for blade damage if mower strikes a rock, branch or other foreign object during mowing!

DANGER

Exercise caution when working under the deck as the mower blades are extremely sharp. Wearing gloves is advisable when working around or with the blades.

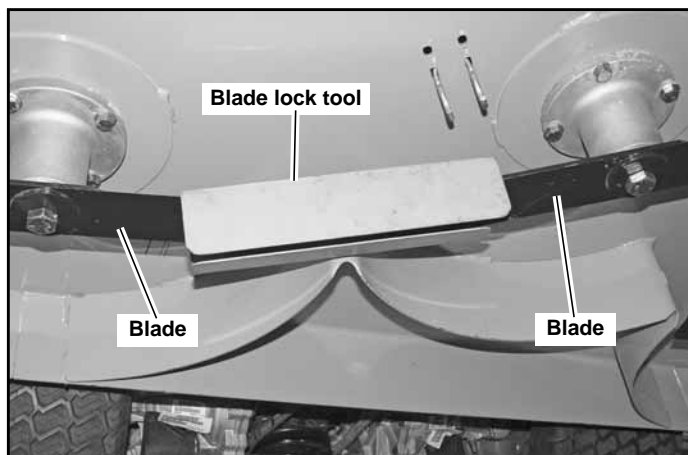

Figure 6-7

4. Use a 15/16" wrench to remove the 5/8" cap screw holding the blade to the spindle shaft.

NOTE: Only remove and install one blade at a time when using the blade lock tool (381442) as it requires two blades to work properly.

5. Inspect the blade for damage. If the blade is damaged, replace it. If the blade is not damaged, either sharpen it or replace it with a new blade or another sharpened used blade.

WARNING

Never attempt to straighten a bent blade by heating, or weld a cracked or broken blade as the blade may break and cause serious injury.

6. If sharpening the blade, refer to the *Mower blade maintenance* section for proper sharpening procedures.
7. When attaching the blade to the spindle shaft do not re-use spindle bolts which have stripped, worn or undercut threads. Torque bolts on spindles to 118 foot-pounds (160 N-m) when reinstalling blades.

IMPORTANT: The blade sail (curved part) must be pointing upward toward the inside of the deck to ensure proper cutting.

WARNING

Rotate the blades after installation to ensure blade tips do not touch each other or sides of the mower.

WARNING

Failure to correctly torque the bolt may result in the loss of the blade which can cause serious injury.

8. Remove the blade lock.
9. Raise the front of the mower and remove the jack stands.
10. Lower the mower.
11. Re-attach the negative battery cable.

Deck Belt

Inspect belts frequently for wear and serviceability. Replace a belt that shows signs of severe cuts, tears, separation, weather checking and cracking, or burns caused by slipping. Slight raveling of belt covering does not indicate failure; trim ravelings with a sharp knife.

Inspect the belt pulley grooves and flanges for wear. A new belt, or one in good condition, should never run against the bottom of the groove. Replace the pulley when this is the case, otherwise, the belt will lose power and slip excessively.

Never pry a belt to get it on a pulley as this will cut or damage the fibers of the belt covering.

Keep oil and grease away from belts, and never use belt dressings. Any of these will destroy the belt composition in a very short time.

Deck belt adjustment

The spindle belt tension remains constant by means of a tension idler and spring. There is no tension adjustment of this belt. Figure 1-1

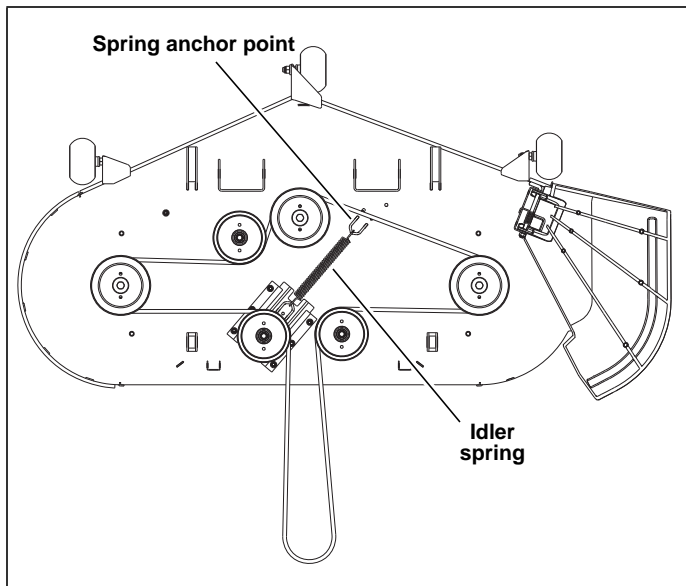
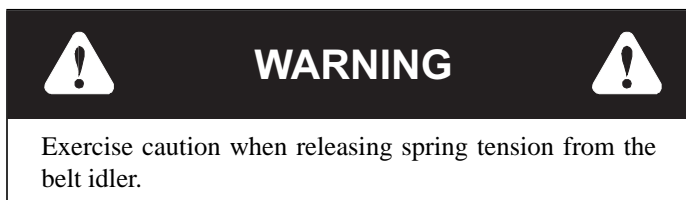
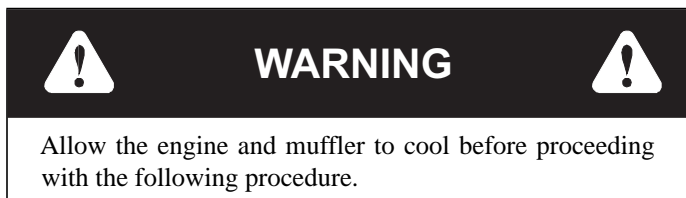

Figure 6-8

Deck belt replacement



1. Park the mower on a flat surface and stop the engine. Make sure deck clutch switch is in the down (OFF) position. Remove ignition key. Place the steering control levers in the park brake position. Make sure the blades are stopped before leaving seat. Disconnect the negative battery cable.
2. Lower the deck to the lowest setting.
3. Remove the deck covers. Figure 6-9
4. Using a tension spring hook (Hustler part number 604462) disconnect the tension idler spring from the spring mount to release tension from the deck drive belt. Figure 6-10
NOTE: The spring and spring mount will become loose and can become misplaced. Set these aside after removal for easier access upon re-assembly.
5. Remove the deck drive belt from the deck spindle pulleys and idler pulley.
6. Remove the deck drive belt from the electric clutch pulley located on the engine shaft. Figure 6-11

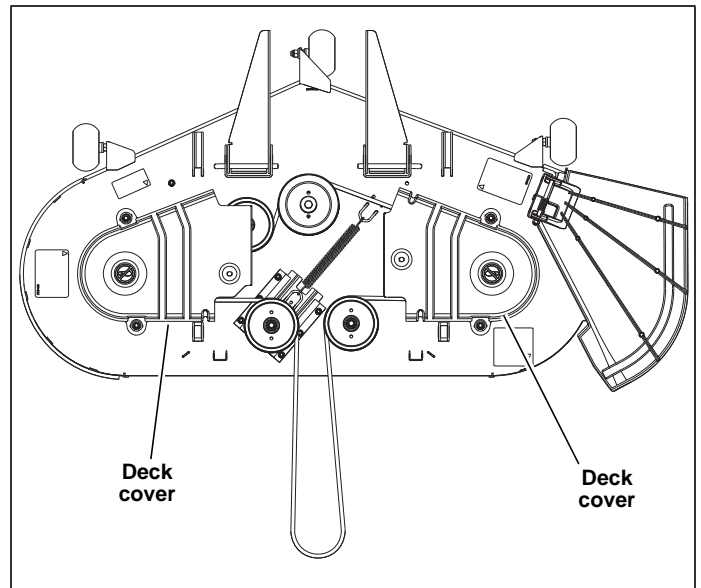

Figure 6-9

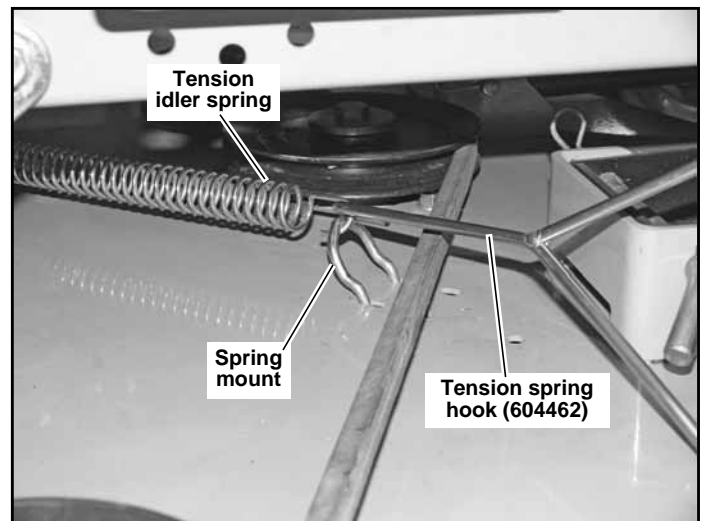
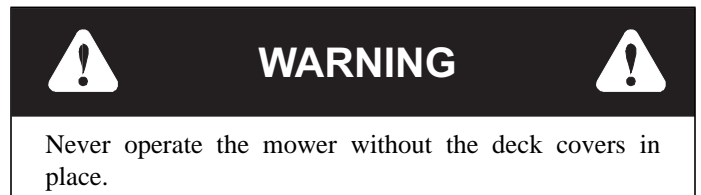

Figure 6-10

7. Route the new deck drive belt around the clutch pulley, spindle pulleys and stationary idler pulley. Make certain the belt is routed properly. Figure 6-8 & Figure 6-11
8. Using the tension spring hook (604462), re-tension the deck drive belt by pulling on the deck belt idler spring and hooking it in the spring mount on the deck. Figure 6-10
9. Re-install the deck covers. Figure 6-9
10. Re-attach the negative battery cable.



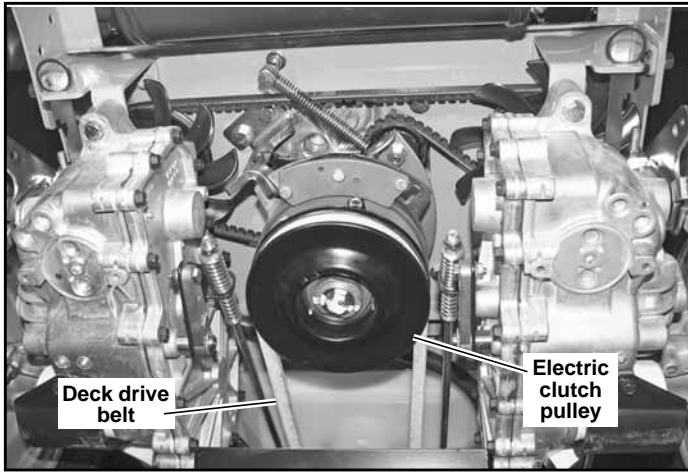

Figure 6-11

The following notes are the same for the different decks shown.

1. There is no tension adjustment of this belt
2. Route belt as shown.

48"/54"/60" Deck Belt Routing

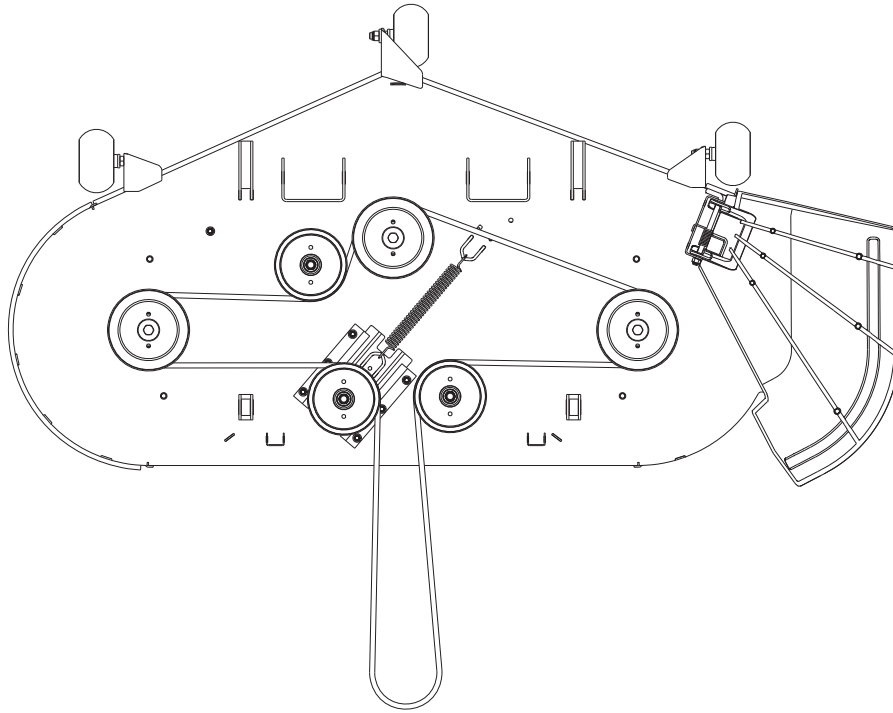
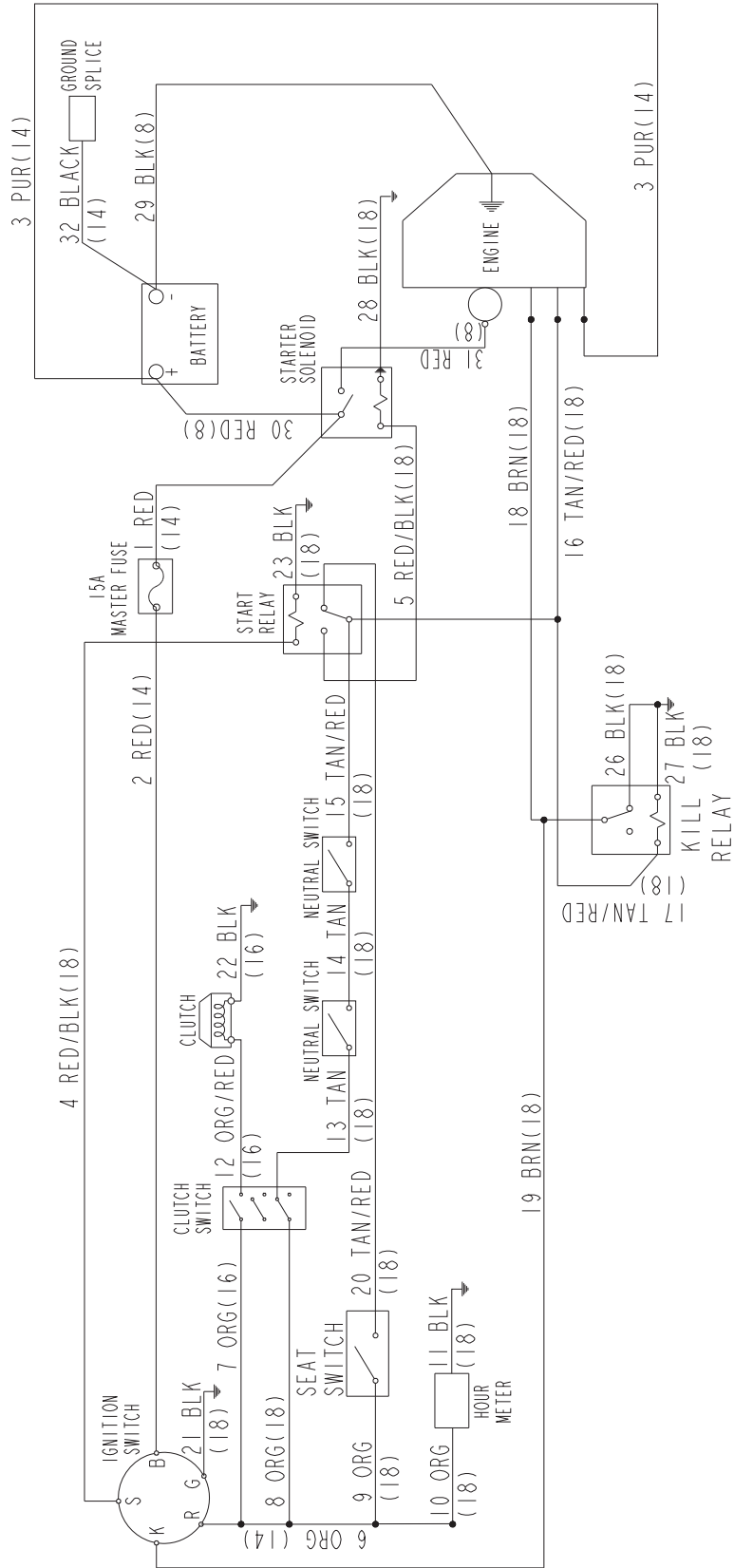

Figure 6-12

ELECTRICAL

Electrical Schematic — Kawasaki



MAINTENANCE

Maintenance Schedule		
Refer to Figure 8-1, Figure 8-2, Figure 8-3, Figure 8-4 & Figure 8-5		
SERVICE AT INTERVALS INDICATED	WEEKLY OR 40 HOURS	ANNUALLY OR 100 HOURS
Verify safety start interlock system	Prior to each use	
Visually inspect unit for loose hardware and/or damaged parts	Prior to each use	
Visually inspect tires	Prior to each use	
Check oil level, engine (1)	Prior to each use or every 4 hours	
Clean air intake screen (4)	Prior to each use or every 4 hours	
Check fuel level	Prior to each use	
Blades - sharpen & securely fastened	Prior to each use	
Discharge chute - securely in place & in lowest position	Prior to each use	
Check tire pressure with a gauge	Prior to each use	
Clean engine and transaxle compartment	After each use	
Change engine oil & filter (1)(3)	X	
Check battery connections	X	
Clean engine exterior (a)	X	
Replace air cleaner paper element (4)		X
Check pump & deck belt tension and condition (5)		X
Check fuel system (6)		X
Check fuel tank grommet (6)		X
Tighten lug nuts on wheels (2)		X
Change fuel filter (6)		X
Replace fuel evaporation system filter (7)		X

NOTES:

1. Initial oil change is after 5 hours of operation. Thereafter, change oil after every 40 hours operation. Change more often under dusty or dirty conditions and during hot weather periods.
2. Torque initially and after first 2 hours of operation.
3. Change engine oil filter per the engine manufacturer’s recommendations. Refer to Engine Owner’s Manual for recommendations and other maintenance items..
4. Service more often under dusty or dirty conditions.
5. **Pump drive belt only - Inspect every month** and replace if worn or cracking is noticed. Otherwise, **replace every 2 years**.
6. Check fuel system for any crack or leaks including, but not limit to, fuel line hoses, fuel valve, vent line hoses, vent valve, vapor valve, carbon canister, and grommets. Replace as needed.
7. More often under dusty or dirty conditions and during hot weather.

REFERENCES:

- A. Refer to engine owner’s manual for engine service information.
NOTE: After completing maintenance cycle (100 hours), repeat cycle.

Maintenance Locator Chart

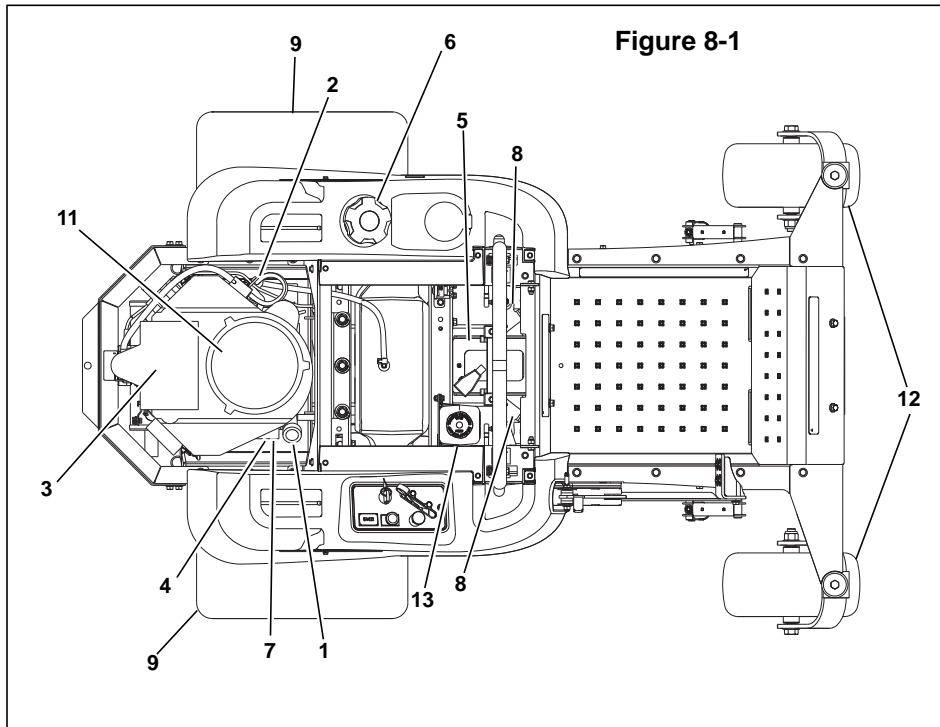

- 1. Engine Oil Fill & Dipstick
- 2. Fuel Filter
- 3. Engine Air Cleaner
- 4. Engine Oil Drain Valve
- 5. Battery
- 6. Fuel Tank
- 7. Engine Oil Filter
- 8. Park Brake Switch (2)
- 9. Drive Tire
- 10. Pump Belt
- 11. Engine Air Intake Screen
- 12. Front Wheel Tires
- 13. Hydraulic Oil Expansion Tank
- 14. Deck Belt
- 15. Blades
- 16. Fuel Evaporation System Filter
- 17. Carbon Canisters

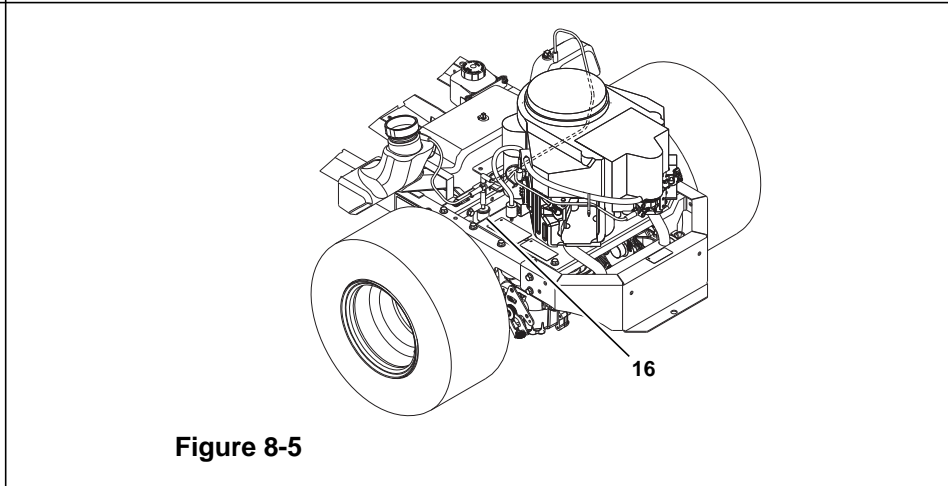
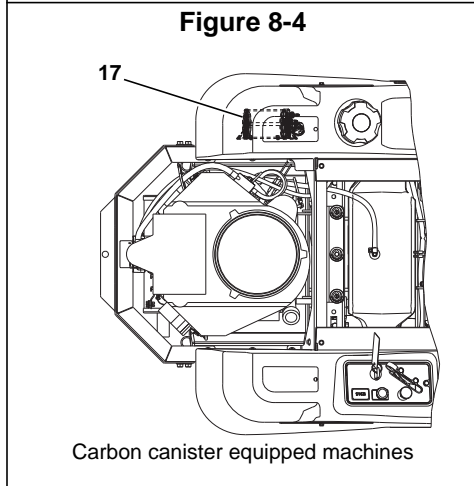
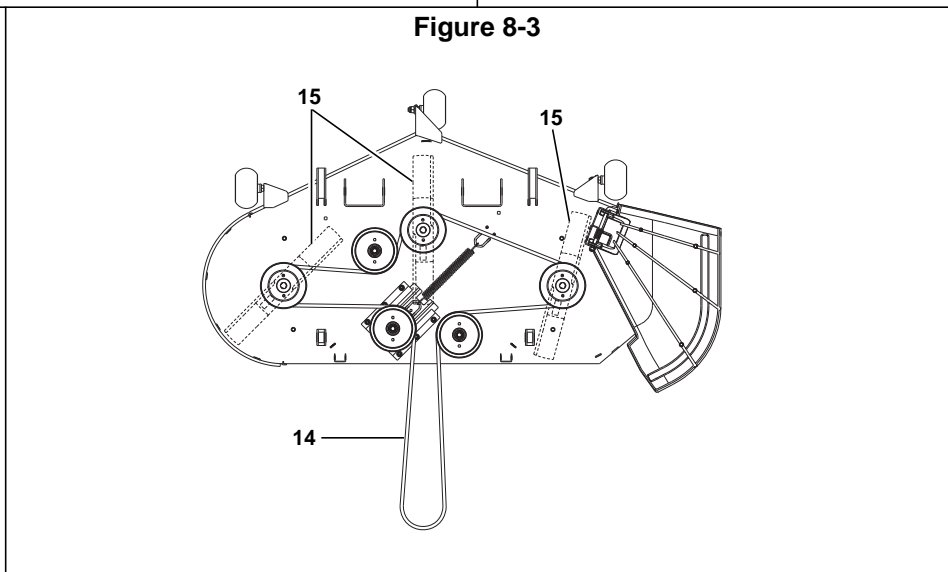
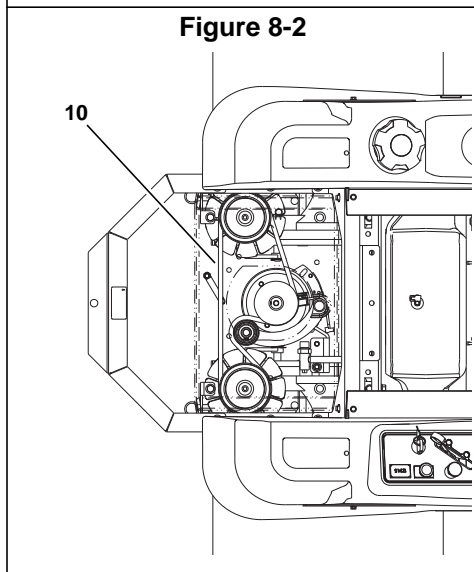

TROUBLESHOOTING

SYMPTOMS	PROBABLE CAUSES	SUGGESTED REMEDIES
Starting motor does not crank	Steering control levers not in park brake position or switch not adjusted	Place steering control levers in park brake position or re-adjust switch
	Deck clutch switch engaged	Disengage clutch switch
	Weak or dead battery	Recharge or replace
	Electrical connections are corroded or loose	Check the electrical connections
	15 amp fuse is blown	Replace the 15 amp fuse
	For additional causes	See engine manual
The engine will not start, starts hard or fails to keep running	No fuel or line plugged	Fill tank or replace line (See <i>Fuel System</i> section for more details)
	There is incorrect fuel in the fuel system	Drain the tank and replace the fuel with the proper type
	There is dirt in the fuel filter	Replace the fuel filter
	Dirt, water or stale fuel in the fuel system	Contact your Dealer
	The choke is not on	Move the choke lever to ON
	Numerous	See engine manual
Engine: Runs with continuous misfiring or engine runs unevenly or erratically	Numerous	See engine manual
Loss of power or system will not operate in either direction	Restrictions in air cleaner	Service air cleaner
	Poor compression	Contact your Dealer
	Steering linkage needs adjustment	Adjust linkage
	Tow valve open	Close tow valve
	The traction drive belt is worn, loose or broken	Install a new traction drive belt
For additional causes	See engine manual	
Air cooled engine over-heating	Air intake screen or cooling fins clogged	Clean screen and fins
	For additional causes	See engine manual
Low engine oil pressure	Low oil level	Add oil
	Oil diluted or too light	Change oil and check for source of contamination
	Failed oil pump	Contact your Dealer
High oil consumption	Numerous	Contact your Dealer
Mower jerky when starting or operates in one direction only	Steering control linkage needs adjustment	Adjust linkage
	Loose steering linkage	Tighten linkage
	Transaxle component faulty	Contact your Dealer

SYMPTOMS	PROBABLE CAUSES	SUGGESTED REMEDIES
Mower creeps when steering control levers are in neutral	Steering linkage needs adjustment	Adjust linkage
Mower circles or veers in one direction	Steering linkage needs adjustment	Adjust linkage
	Loose steering linkage	Tighten linkage
	Tires improperly inflated	Adjust air pressure to 8 - 12 psi (55 - 83 KPa)
	Transaxle component faulty	Contact your Dealer
Mower creeps when parking brake engaged	Steering linkage out of adjustment	Adjust steering linkage
	Brakes need adjustment	Adjust parking brakes
There is abnormal vibration	The engine mounting bolts are loose	Tighten the engine mounting bolts
	The engine pulley, idler pulley or blade pulley is loose	Tighten the appropriate pulley
	The engine pulley is damaged	Contact your Dealer
	The cutting blade(s) is/are bent or unbalanced	Install new cutting blade(s)
	A blade mounting bolt is loose	Tighten the blade mounting bolt
	Spindle bearing is worn or loose	Replace or tighten spindle bearing
	A blade spindle is bent	Contact your Dealer
Blades do not rotate	The deck drive belt is worn, loose or broken	Install a new deck drive belt
	The deck drive belt is off the pulley	Install the deck drive belt and check for a reason
	Electric clutch is not engaging	Check and/or replace 15 amp fuse. Contact your Dealer
Uneven cutting height	The blade(s) are not sharp	Sharpen the blades
	A cutting blade(s) is/are bent	Install new cutting blade(s)
	The deck is not level	Level the deck per the <i>Deck leveling</i> section of the General Service Manual
	An anti-scalp wheel is not set correctly	Adjust the height of the anti-scalp wheel
	The underside of the deck is dirty	Clean the underside of the deck
	Tires improperly inflated	Adjust air pressure to 8 - 12 psi (55 - 83 KPa)
A blade spindle is bent	Contact your Dealer	

INDEX

	PAGE		PAGE
Belt Adjustment	4-3	Maintenance introduction	1-1
Belt replacement	4-4	Maintenance locator chart	8-2
Blades	6-2	Maintenance precautions	2-2
Carbon canister	5-1	Mower blade maintenance	6-2
Control lever stops adjustment	4-2	Mower blade replacement	6-3
Deck belt	6-3	Operate machine safely	2-2
Deck belt adjustment	6-4	Operation Precautions	2-2
Deck belt replacement	6-4	Park brake spring adjustment	4-3
Deck Belt Routing	6-6	Pre-operation precautions	2-1
Deck leveling	6-1	Purging procedure	4-7
Electrical Schematic	7-1	Safe servicing practices	2-1
Engine air filter	5-1	Special torques	3-1
Engine oil and filter	5-1	Standard torques	3-1
Engine RPM settings	5-3	Steering adjustments	4-1
General engine maintenance	5-1	Steering control lever neutral adjustment	4-1
General maintenance precautions	2-2	Tires	4-7
Hustler service program	1-1	Transaxle Drive Belt	4-3
Hydraulic System	4-5	Warranty	1-1