

(For official use only)



(भारत सरकार/Govt. of India)
(रेल मंत्रालय/Ministry of Railways)

Handbook on Air Brake System of Freight Stock



CAMTECH/2011-12/M /Fr. Air br. system/1.0

February 2012

अभ्यास RDS
रेल अग्रदूत Transforming Railways



Indian Railways
Centre for Advanced Maintenance Technology
Maharajpur, Gwalior – 474 005

मालगाड़ी में प्रयुक्त
एयर ब्रेक सिस्टम
पर हस्तपुस्तिका

**Handbook on
Air Brake System
of Freight Stock**

PREFACE

Air Brake freight stocks on Indian Railway are fitted with single pipe/ twin pipe graduated release air brake system. Air brake system is most efficient and reliable braking system used to run heavy and long trains at high speeds. Recently, Bogie mounted Brake System (BMBS) has been introduced for freight stock. The details of BMBS for freight stocks are given in this handbook.

The objective of this book is to provide a tool to the staff involved in maintenance of freight trains to reduce cases of Air brake system failures thereby improving safety & reliability of freight stock. This handbook prepared by the CAMTECH with the purpose of disseminating the information to all those in freight stock maintenance field.

This hand book is aimed at assisting concerned staff and does not supersede any existing instructions from Railway Board, RDSO or IRCA etc. Most of data and informations mentioned here in are available in some form the other in various books and manuals or other printed matter. If any changes are made, these will be used in the form of correction slips. For convenience, this book includes a proforma for entering all correction slips serially.

We welcome any suggestion for addition and improvements from our readers.

Date: - 28.02.2012

**K.P. Yadav
Director/ Mech
CAMTECH/GWL**

CONTENTS

	Description	Page No.
	Preface	i
	Contents	ii
	Correction slips	iii
1.0	Introduction.	1
1.1	Classification of air brake system.	1
1.2	Single pipe graduated release air brake system.	1
1.3	Twin pipe graduated release air brake system.	6
1.4	Uncommon items for twin pipe air brake system.	10
1.5	Marking of twin pipe air brake fitted wagons.	11
1.6	Bogie mounted brake system (BMBS).	11
1.7	Merits over conventional brake system.	17
2.0	Main components.	21
2.1	Distributor Valve	22
2.2	Common pipe bracket.	28
2.3	Intermediate piece (Sandwich piece).	29
2.4	Brake pipe & feed pipe hoses.	30
2.5	Brake pipe & feed pipe coupling	30
2.6	Cut off angle cock.	34
2.7	Brake cylinder.	40
2.8	Dirt collector.	48
2.9	Auxiliary reservoir.	54
2.10	Guard's emergency brake valve.	57
2.11	Quick coupling arrangement.	61
2.12	Slack adjuster.	62
2.13	Procedure for brake rigging setting and measurement of "A" and "e" dimensions.	70

AIR BRAKE SYSTEM FOR FREIGHT STOCK

1.0 INTRODUCTION

In the air brake system, a lot of developments have taken place such as bogie mounted Air brake system, Twin pipe air brake system, Automatic load sensing device etc,. As a result, the maintenance and requirements have changed considerably.

Recently, Bogie mounted Brake System (BMBS) has also been introduced for freight stock. The details of BMBS for freight stocks are given in this handbook.

1.1 CLASSIFICATION OF AIR BRAKE SYSTEM

On the basis of type of release, air brake system is classified as:

- Direct release air brake system
- Graduated release air brake system

Both Direct and Graduated release are further available in two forms viz.

- Single pipe and
- Twin pipe

On the basis of fitment, air brake system is classified as:

- Under frame mounted air brake system
- Bogie mounted air brake system

1.2 SINGLE PIPE GRADUATED RELEASE AIR BRAKE SYSTEM

Some of the Air Brake goods stock on IR is fitted with single pipe graduated release air brake system. In single pipe, brake pipes of all wagons are connected. Also all

the cut off angle cocks are kept open except the front cut off angle cocks of BP of leading loco and rear end cut off angle cock of BP of last vehicle. Isolating cocks on all wagons are also kept in open condition. Auxiliary reservoir is charged through distributor valve at 5.0 kg/cm^2 .

A. Charging stage

During this stage, brake pipe is charged to 5 kg/cm^2 pressure which in turn charges control reservoir and auxiliary reservoir to 5 kg/cm^2 pressure via distributor valve. At this stage, brake cylinder gets vented to atmosphere through passage in Distributor valve.

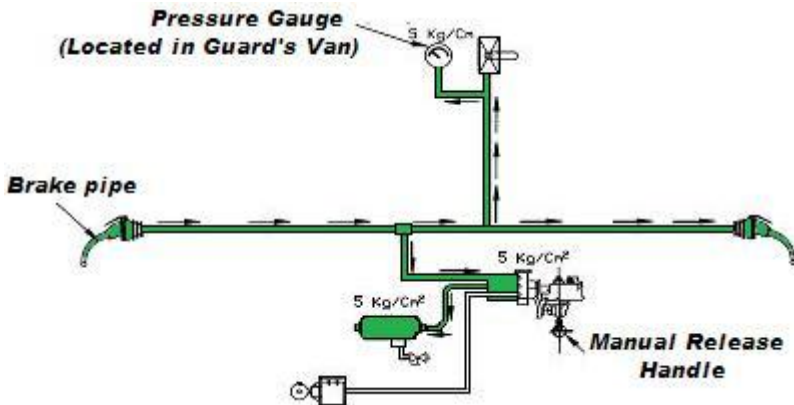

FIG. 1. CHARGING

B. Application Stage

For application of brakes, the pressure in brake pipe has to be dropped. This is done by venting air from driver's brake valve. Reduction in brake pipe pressure positions the distributor valve in such a way that the control

reservoir gets disconnected from brake pipe and auxiliary reservoir gets connected to brake cylinder. This results in increase in air pressure in brake cylinder resulting in application of brakes. The magnitude of braking force is proportional to reduction in brake pipe pressure.

Note: Brake Application takes places when Brake pipe pressure is dropped by Intentional or Accidental.

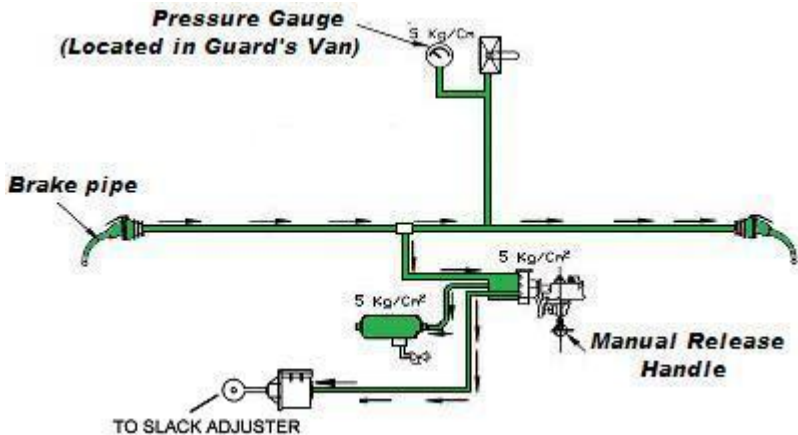

FIG. 2. APPLICATION

C) Release stage

For releasing brakes, the brake pipe is again charged to 5 kg/cm² pressure by compressor through driver's brake valve. This action positions distributor valve in such a way that auxiliary reservoir gets isolated from brake cylinder and brake cylinder is vented to atmosphere through distributor valve and thus brakes are released.

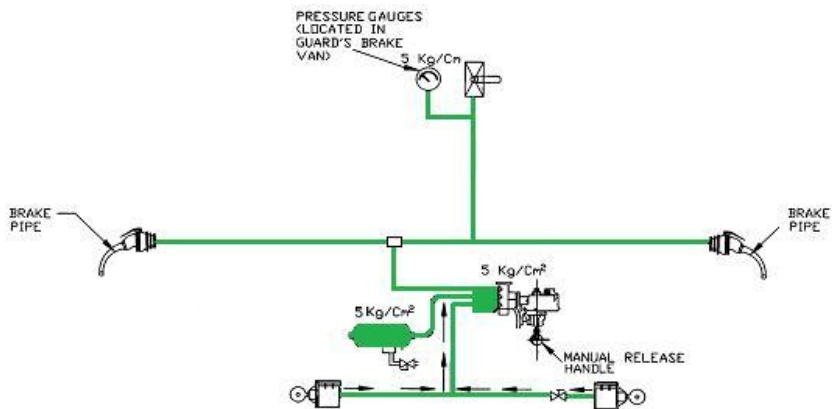

FIG. 3. RELEASE

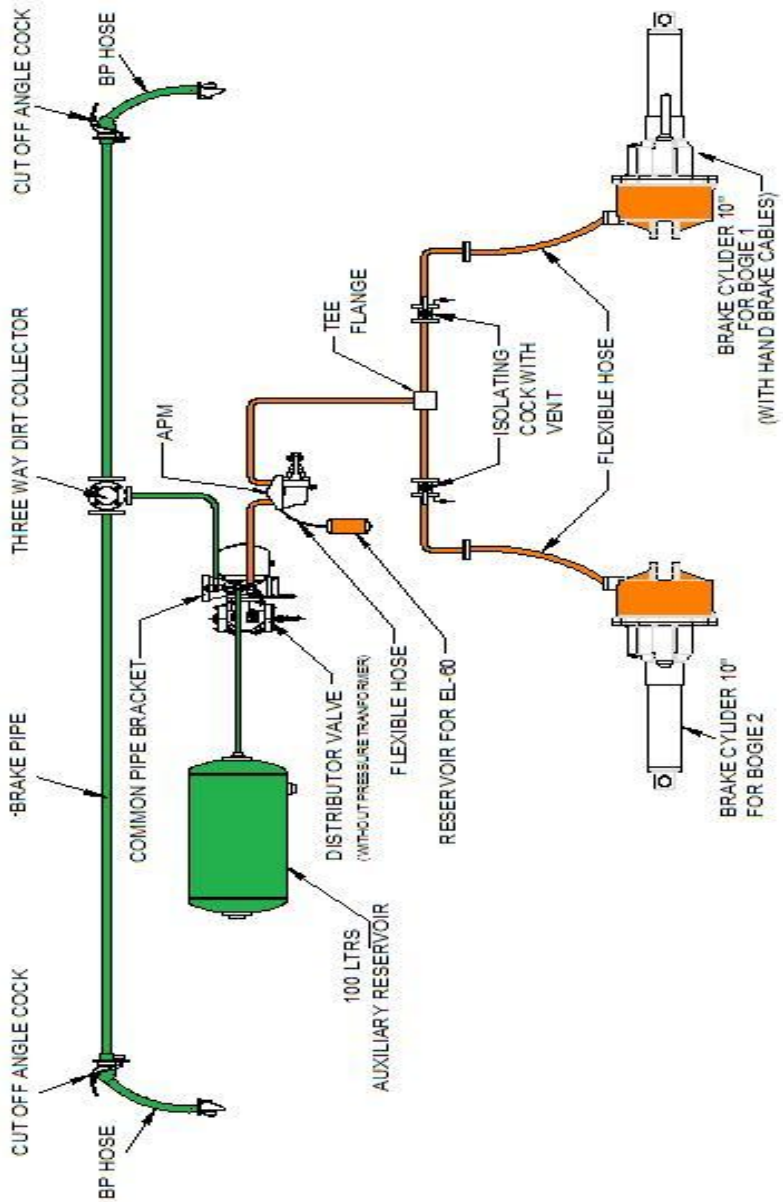

FIG. 4. LAYOUT OF SINGLE PIPE AIR BRAKE SYSTEM

1.3 TWIN PIPE GRADUATED RELEASE AIR BRAKE SYSTEM

Some of the Air Brake goods stock is fitted with Twin pipe graduated release air brake system. In Twin pipe, brake pipes and feed pipes of all wagons are connected. Also all the cut off angle cocks are kept open except the front cut off angle cocks of BP/ FP of leading loco and rear end cut off angle cock of BP and FP of last vehicle. Isolating cocks on all wagons are also kept in open condition. Auxiliary reservoir is charged to 6.0 Kg/cm^2 through the feed pipe.

A. Charging stage

During this stage, brake pipe is charged to 5 kg/cm^2 pressure and feed pipe is charged to 6 kg/cm^2 pressure which in turn charges control reservoir and auxiliary reservoir to 6 kg/cm^2 pressure. At this stage, brake cylinder gets vented to atmosphere through passage in Distributor valve.

B. Application Stage

For application of brakes, the pressure in brake pipe has to be dropped. This is done by venting air from driver's brake valve. Reduction in brake pipe pressure positions the distributor valve in such a way that the control reservoir gets disconnected from brake pipe and auxiliary reservoir gets connected to brake cylinder. This results in increase in air pressure in brake cylinder resulting in application of brakes. The magnitude of braking force is proportional to reduction in brake pipe pressure

Note: Brake Application takes places when Brake pipe pressure is dropped by Intentional or Accidental.

C. Release stage

For releasing brakes, the brake pipe is again charged to 5 kg/cm² pressure by compressor through driver's brake valve. This action positions distributor valve in such a way that auxiliary reservoir gets isolated from brake cylinder and brake cylinder is vented to atmosphere through distributor valve and thus brakes are released.

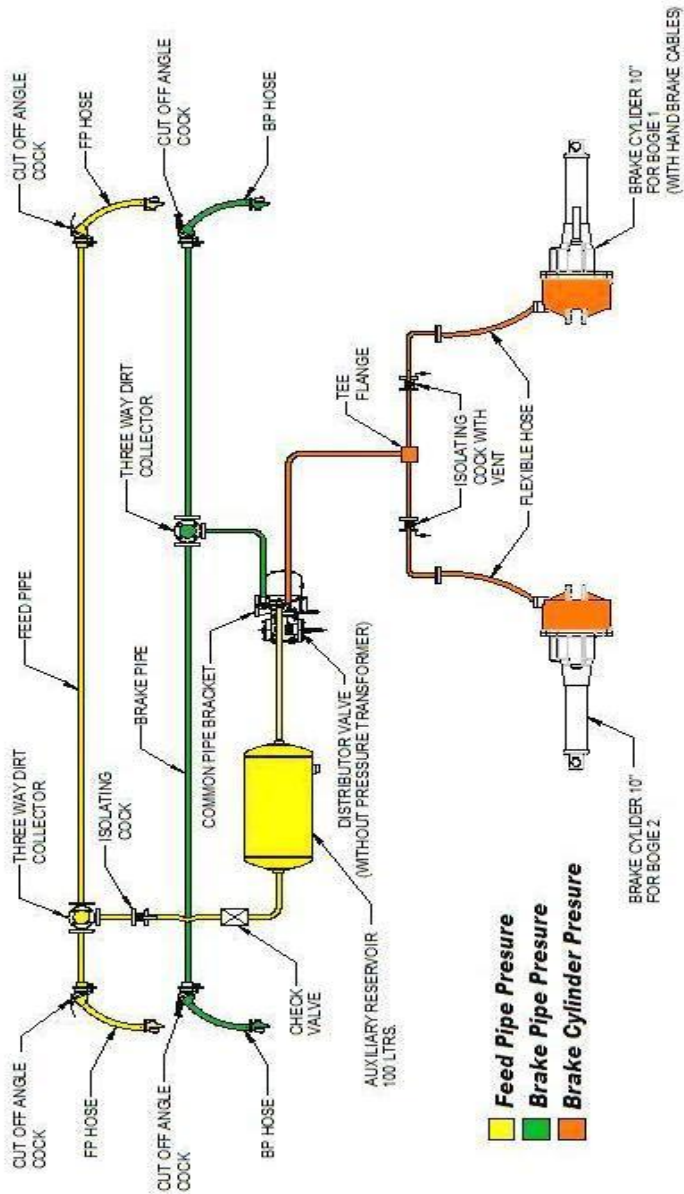

FIG. 5. LAYOUT OF TWIN PIPE AIR BRAKE SYSTEM

Do's and Don'ts for Twin Pipe working of Freight Trains

Do's

1. Do ensure that the all twin pipe Wagons are operated in CC rakes only.
2. Do ensure that loco provided for twin pipe rake is having its twin pipe in working condition.
3. Do ensure availability of spare pool of twin pipe wagon & brake van, for replacement, if required.
4. Do ensure availability of spare feed pipe in loco.
5. Do ensure that brake van provided for twin pipe working is having twin pipe system.
6. Do ensure BP coupling heads are marked with 'BP' and painted in green.
7. Do ensure FP coupling heads are marked with 'FP' and painted in white.
8. Do ensure that BP & FP hose couplings at the rear end of the train are placed on their respective hose coupling supports.
9. Do ensure that pressure gauges for BP and FP are provided in the brake van.
10. Do ensure that brake pipe/feed pipe angle cocks are not closed under any circumstance, either for isolation of wagons or for any purpose whatsoever, except for carrying out shunting operation, after which the angel cocks should again be opened to ensure continuity of brake pipe and feed pipe.
11. Do ensure that the isolating cock of feed pipe of all the wagons in the open position. The handle of cock shall be vertically down when open and at horizontal when closed.
12. Do ensure that gauge in guards compartment show pressure not less than 5.8 kg/cm² in feed pipe after the system is fully charged.
13. Do ensure that feed pipe hose coupling are connected to form a continuous passage from locomotive to last vehicle.

14. Do ensure that feed pipe Cut off angle cocks, except at the rear of train, are kept open.
15. Do ensure availability of the quick coupling for attaching and detaching the pressure gauges for BP/FP in brake van.
16. Do ensure that the leakage in brake system is less than 0-25kg/cm² per minute.
17. Do close BP/FP angle cocks of adjacent wagons to uncouple hose couplings.

Don'ts

1. Do not allow single pipe coupling.
2. Do not allow a feed pipe to be connected to the brake pipe anywhere in the train or vice versa.
3. Do not allow a feed pipe hose coupling at rear end to dangle.
4. Do not allow train to leave with leakage higher than specified.
5. Do not allow train to leave with feed pipe pressure in loco and brake van less than specified.

1.4 UNCOMMON ITEMS FOR TWIN PIPE AIR BRAKE SYSTEM

SN	Description	No. of	Ref. Drg.
1.	Air Brake Hose Coupling (F.P.)	2	WD-81027-S-01
2.	Isolating Cock	1	WD-83062-S-04
3.	Check Valve	1	WD-83062-S-03
4.	Pipe 20 N.B.	1	WD-09082-S-02 ITEM-9
5.	Pipe 20 N.B.	1	WD-09082-S-02 ITEM-8
6.	Pipe 20 N.B.	1	WD-09082-S-02 ITEM-10
7.	Pipe 32 N.B. (F.P.)	1	WD-09082-S-02 ITEM-4
8.	Pipe 32 N.B. (F.P.)	1	WD-09082-S-02 ITEM-2

1.5 MARKING OF TWIN PIPE AIR BRAKE FITTED WAGONS

For easy identification of these wagons, 'Twin Pipe' written in black letters on yellow background and encircled in white band shall be marked on side panel, one side in English and other side in Hindi as specified in RDSO drawings.

NOTE: For further details please refer Annexure XIX of G-97 amendment No. 3 of Jan. 2010 for "General guidelines for operation and examination of Twin Pipe Air Brake system of complete train" and RDSO report No. MP. Guide No. 11 (Rev. -01) "Procedure for checking of Diesel/Electric locomotive Hauled Air Braked Trains (Fitted with twin pipe air brake system)"

1.6 BOGIE MOUNTED BRAKE SYSTEM (BMBS)

Bogie mounted brake system has been introduced for the freight stock in Indian Railways to reduced maintenance and tare weight of the stock. In BMBS, brake cylinder is mounted parallel to the brake beams and transfers forces through the bell cranks.

The Bogie mounted brake system is designed for single pipe/twin pipe graduated release brake system with automatic two stage braking. Its working principle is as follows:

The wagons are provided with automatic two-stage Automatic Brake Cylinder Pressure Modification Device to cater for higher brake power in loaded condition instead of the conventional manual empty load device. With the provision of this, brake cylinder pressure of 2.2 Kg/cm² is obtained in empty condition and 3.8 Kg/cm² is obtained in the loaded condition.

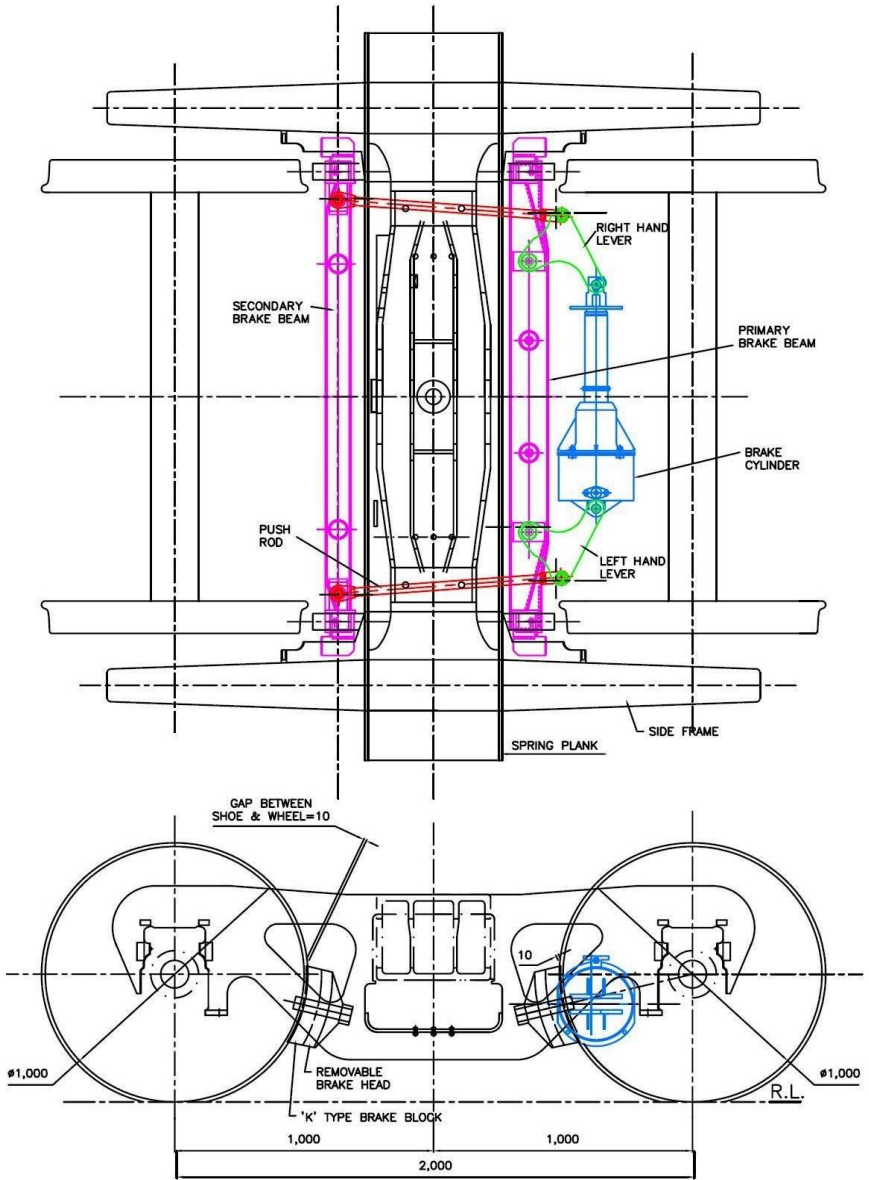

FIG. 6. DIAGRAM OF BOGIE FITTED WITH BMBS

To obtain this a change over mechanism, "Automatic Brake Cylinder Pressure Modification Device" (APM) is interposed between the under frame and side frame of the bogie. The mechanism gets actuated at a pre-determined change over weight and changes the pressure going to the brake cylinder from 2.2. Kg/cm² to 3.8 Kg/cm² and vice -versa.

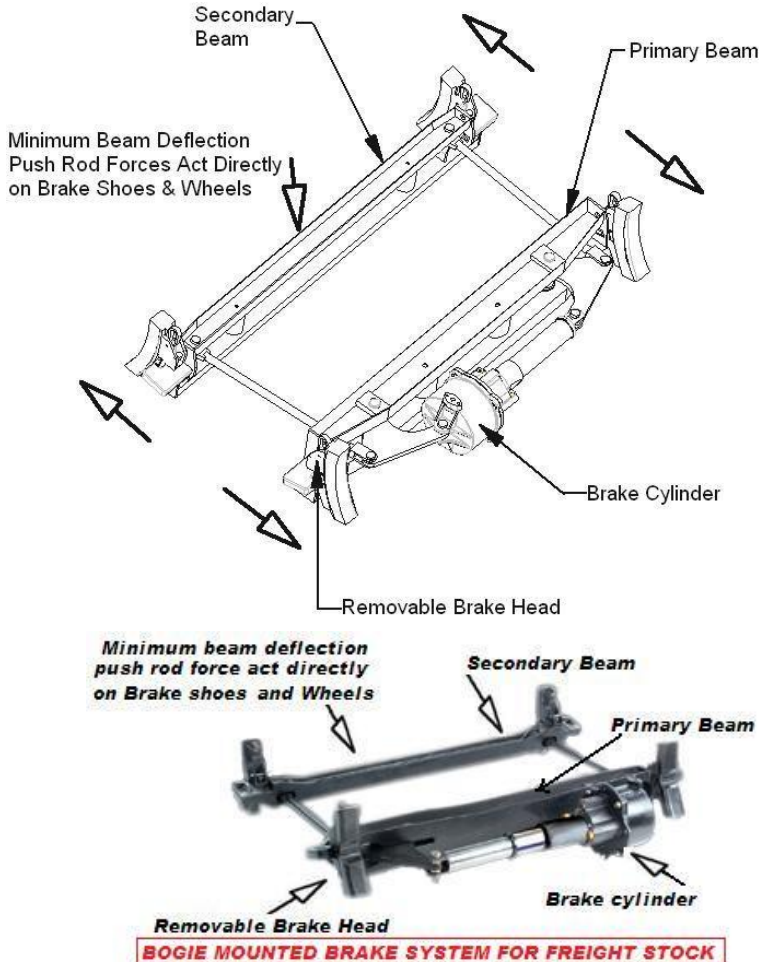

FIG. 7. BRAKE BEAM ASSLY.

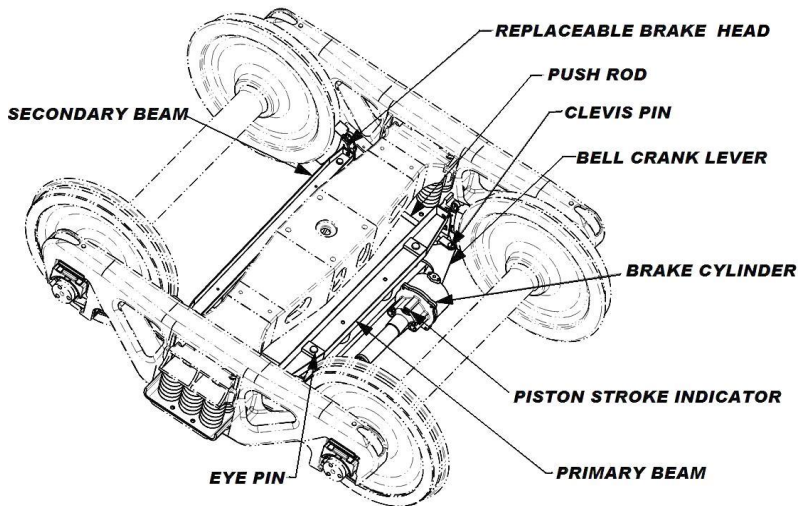

FIG. 8. BOGIE FITTED WITH BMBS

For application of brake, air pressure in the brake pipe is reduced by venting it to the atmosphere from drives brake valve in the locomotive. The reduction of the brake pipe pressure, positions the distributor valve in such a way that the auxiliary reservoir is connected to the brake cylinder through APM device and thereby applying the brake. During full service brake application, a reduction of 1.4 to 1.6 Kg/cm² takes, a maximum brake cylinder pressure of 3.8 Kg/cm² in loaded condition and 2.2 Kg/cm² in empty condition is developed. Any further reduction of brake pipe pressure has no effect on the brake cylinder pressure. During emergency brake application, the brake pipe is vented to atmosphere very quickly; as a result the distributor valve acquires the full application position also at a faster rate. This result in quicker built up of brake cylinder pressure but the maximum brake cylinder pressure will be the same as that obtained during a full service brake application.

For release of brakes, air pressure in the brake pipe is increased through driver's brake valve. The increase in the brake pipe pressure results in exhausting the brake cylinder pressure through the distributor valve. The decrease in the brake cylinder pressure corresponds to the increase in the brake pipe pressure. When the brake pipe pressure reaches 5 Kg/cm², the brake cylinder pressure exhausts completely and the brakes are completely released.

Brake Cylinder with built-in Double acting Slack Adjuster

The brake cylinder receives pneumatic pressure from auxiliary reservoir after being regulated through the distributor valve and Automatic Brake Cylinder Pressure Modification Device develops mechanical brake power by outward movement of its piston and arm assembly.

The piston rod assembly is connected to the brake shoes through a system of rigging levers to amplify and transmit the brake power. The compression spring provided in the brake cylinder bring back the rigging to its original position when brake is released.

The built in slack adjuster compensates for the wear of brake blocks during the brake application through equivalent pay-out. For pay in, the pry bar is applied between the brake shoe and wheel and the rigging is pushed in.



FIG. 9. BRAKE CYLINDER - 10" DIA.

Automatic Brake Cylinder Pressure Modification Device (APM)

APM device is interposed between bogie side frame of Casnub bogie and the under frame of wagons. It is fitted on one of the bogies of the wagon for achieving two stage load braking with automatic changeover of brake power. It restricts the brake cylinder pressure coming from the Distributor valve to $2.2 \pm 0.25 \text{ Kg/cm}^2$ in empty condition of the wagon and allows the brake cylinder pressure of $3.8 \pm 0. \text{ Kg/cm}^2$ in loaded condition of the wagon. APM should sense the gap only at the time of air brake application. During remaining time it should not be in contact with the bogie side frame.



FIG:10 Brake Cylinder Pressure Modification Device

Design Features

- This device does changeover of brake cylinder pressure from empty to load.
- Standard DV can be used.
- The mounting and pipeline connecting of the device is modified according to the standard pipes and flange used, so no major change is required in the piping arrangement. Only brake cylinder pipeline between distributor valve and brake cylinder needs to be modified.
- A visual indicator is provided on the valve, which shows empty load brake conditions.
- There is no physical contact of the sensor arm of device with the side frame of the bogie during release & running (both Empty & Loaded condition)
- The contact of sensing arm with side frame of the bogie occurs during braking only.
- The sensing arm is angular type of lever; hence it does not lead to any bending movement.
- Simplified piping requires only three connections for the Valve.
- The load-sensing device is lightweight, with a minimum number of parts.
- In the empty and loaded position, rock and roll of 44mm will not affect the empty load brake.
- Load and empty adjustment can be easily done on the wagon.

1.7 MERITS OVER CONVENTIONAL BRAKE SYSTEM

More Safety

Two nos. of 10" brake cylinders with inbuilt double acting slack adjuster have been used per wagon. Along with this an automatic load-sensing device has been used for two stage braking (empty / loaded). This delivers optimum braking

performance and hence increases safety parameters.

Reliability

Instead of one 14” cylinder, two 10” cylinders have been provided per wagon (one per bogie)., This increases the system reliability as in case of failure of one cylinder the wagon can be moved on another cylinder with the isolation of failed cylinder.

Cost Reduction

a) Maintenance cost

Two cylinders are provided with inbuilt slack adjuster, re-screwing of slack adjuster is automatic and can be done from the side of the wagon by a crow bar. The system simplified installation and even shoe wear helps extend the turn round time between wagon maintenance intervals.

b) Fitment cost

The BMBS is drop in fit product as new brake beams are provided to slide in the existing chutes of bogie. It is very easy to assemble, no special training or tools are required for assembly.

c) Pay load cost

A unique design that delivers optimum braking performance while minimizing weight. With this system has reduced the tare weight of BOBRN wagon by almost 200 Kgs, which in turn increases the payload.

Easy Retro fitment

This brake system can be easily fitted on any standard bogie without making any modifications. This is a drop in fit system and does not require any kind of modifications in the existing bogie.

Simplified Hand Braking Installation

In this system, hand brake is easy to install provides improved reliability and safety. There is minimum number of levers in the hand brake mechanism.

Replaceable Brake Heads

Improved features replaceable brake heads which do not require disassembly of the bogie for installation. This system is a direct acting system and does not require levers or reverse direction devices.

Integral Double Acting Slack Adjuster

Integral double acting slack adjuster maintains a constant 56mm piston stroke, resulting in uniform and efficient braking performance even as the brake shoes and wheel wear. The slack adjuster has a total make up of 500 mm, compensating for 192 mm of nominal brake shoe wear and 192 mm of nominal wheel wear.

Patented Beam Design

The Beam design dramatically reduces bending loads in the beams, enabling the use of lighter structure with no sacrifice in the performance. In this system, cylinder is mounted parallel to the brake beams and transfers forces through the bell cranks. This parallelogram design improves the efficiency and aligns the braking forces with the wheels, which reduces the shoe and wheel wear.

Under Bolster Design

In this system push rods are positioned under the bolster and can be configured to work with all bogie designs.

1.8 CHANGES REQUIRED WITH EXISTING SYSTEM:

Brake Cylinder

Two numbers of 10” brake cylinders have been used (one per

bogie) with double acting in-built slack adjuster instead of one number of 14" brake cylinder (without in-built slack adjuster). In view of this there is no requirement of external slack adjuster and other relating linkages.

Load Sensing Device

Load sensing device with automatic empty-load change over and adjustable sensing arm according to the change weights of different wagons has been used in place of manual (mechanical) change over system. This change has been implemented without any change in distributor valve.

Beams

New design of beams, fabricated with heavy channels with replaceable brake heads have been used in place of existing beams with fixed brake heads. The beams can be installed in the side pockets of the bogie side frame without making any kind of changes in the existing bogie.

Pipes and Hoses

Five numbers of small 20NB pipe with 2 numbers of 1" flexible hose has been added in place of one pipe from DV to cylinder for making connections with load sensing device and brake cylinder

Brake Blocks

K-type non-asbestos brake blocks have been used in place of L-type blocks.

Hand Brake Cables

In order to reduce hand brake rigging/linkages in the existing system, flexible cables with imported outer sleeve and thick stainless steel inner wire have been used for efficient hand braking.

Other Items

Two nos. of isolating cocks with vent (one for each bogie) for isolation and venting of cylinders, mounting brackets, tie rods and channels for hand brake arrangement have been provided with the system.

2.0 MAIN COMPONENTS

The single pipe/Twin pipe graduated release air brake system and bogie mounted air single pipe/Twin pipe brake system consists of following components:-

- 1) Distributor valve (DV)
- 2) Common pipe bracket with control reservoir.
- 3) Auxiliary reservoir 100 Litres & 75 Liters
- 4) Three way centrifugal dirt collector for BP and FP.
- 5) Isolating cock.
- 6) Brake cylinder 355 mm diameters, 300 mm diameter and 10" diameter.
- 7) Cut off angle cock (32mm size on either ends of BP & FP).
- 8) Air brake hose coupling (32mm for BP & FP).
- 9) Brake pipe and Feed pipe (32mm dia).
- 10) Branch pipes from BP & FP to brake equipment (20mm bore).
- 11) Guard emergency brake valve.
- 12) Pressure gauges for BP and FP.
- 13) Check Valve.

For BMBS

- 14) Primary beam and secondary beam assembly.
- 15) Push rods
- 16) Levers Left Hand & Right Hand
- 17) Load Sensing Device

2.1 DISTRIBUTOR VALVE:

The Distributor valve assembly consists of distributor valve, pipe bracket, adaptor, control reservoir and gasket. All pipe connection to distributor valve are given through the pipe bracket. The distributor valve along with the adaptor can be removed from the pipe bracket without distributing the pipe connection for maintenance purpose.

The control reservoir of six litres volume is directly mounted to the pipe bracket. An isolating cock is provided either on the distributor valve or on the adaptor to isolate the distributor valve when found defective. The handle of the isolating cock will be in vertical position when the distributor valve is in open position and horizontal when the distributor valve is closed position. A manual release handle is provided at the bottom of the distributor valve by which the brake in a particular wagon can be released manually by pulling the handle.

KEO and C₃W type distributor valves with cast iron body have been adopted as standard for freight stock of Indian Railways.

C₃W Distributor Valve

The C₃W Distributor Valve consists of the following main subassemblies:

- i. Main body
- ii. Quick Service valve
- iii. Main valve
- iv. Limiting device
- v. Double release valve
- vi. Auxiliary reservoir check valve
- vii. Cut off valve
- viii. Application choke
- ix. Release choke.

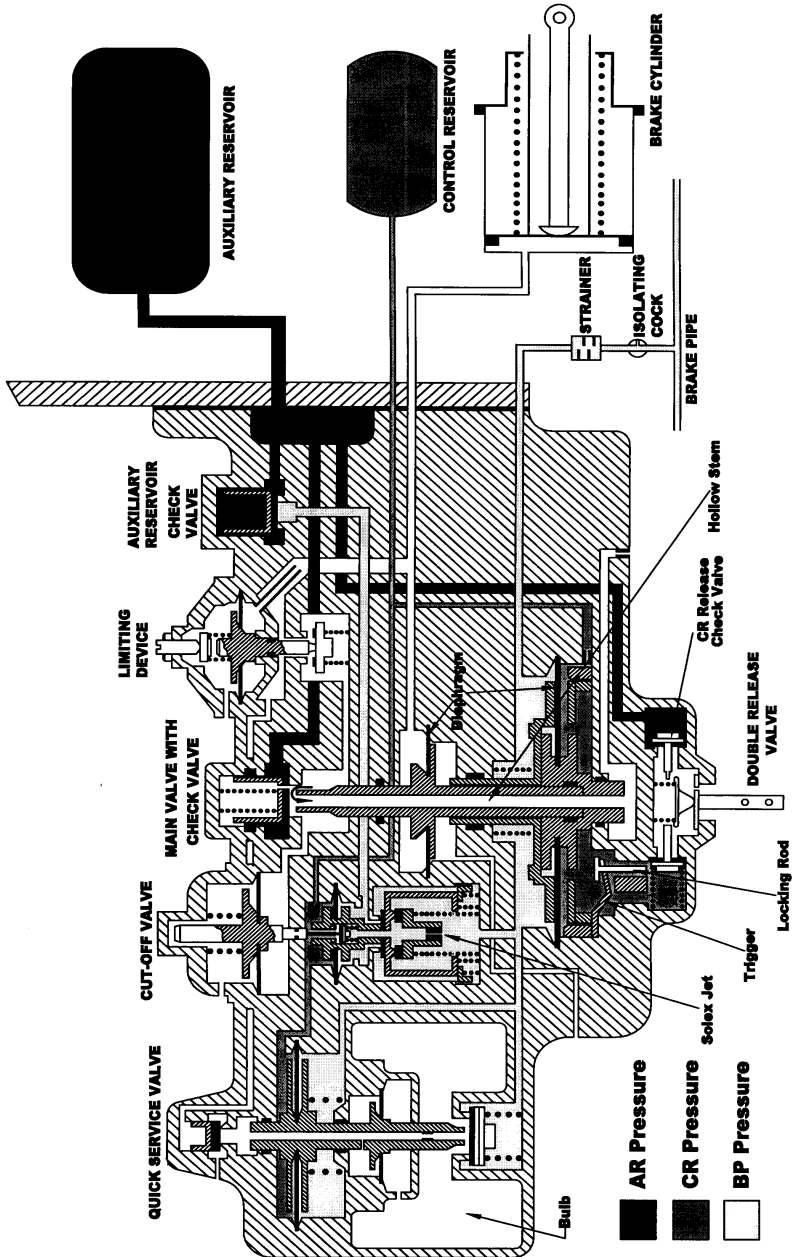

FIG:11 SECTIONAL VIEW OF C3W DISTRIBUTOR VALVE

Features of C₃W Distributor Valve

The brake starts applying within 1 second when brake pipe pressure drops by 0.6 kg/cm² in 6 seconds. The brake does not apply for a slow drop of brake pipe pressure of 0.4 kg/cm² in 60 seconds. If a facility is provided on the locomotive to quickly overcharge the regime pressure at 5 kg/cm² to 6 kg/cm² with a view to obtaining a faster brake release a protective feature is incorporated in the Distributor Valve which prevent the overcharging of control reservoir from 5 kg/cm² to 6 kg/cm² for a period of 50 seconds in freight service.

If the brake pipe regime pressure is set at 5kg/cm², pressure limiting device restricts the maximum brake cylinder pressure to 3.8 kg/cm², irrespective of the drop in brake pipe pressure or the auxiliary reservoir pressure (as long as the auxiliary reservoir is at a sufficient higher pressure than 3.8 kg/cm² even after repeated brake application, in single pipe system). However, after a brake application is made, full brake release is not achievable till the brake pipe pressure builds up to 4.83 kg/cm² with the BP regime pressure set at 5.0 kg/cm².

Application and release graduations of 0.1 kg/cm² are possible. A speed of propagation of around 280m/sec. is achieved due to a built – in Quick Service Valve (optional for use in locomotive service).

Provision is made to “Optimize” the brake release on a vehicle whose full brakes are applied – a feature which comes in handy especially during marshalling operation. In addition, a facility to vent all the brake equipment fully is provided.

It is possible to use the distributor with appropriate attachments with a pneumatic “Empty Load” device, either manually or automatically operated, including an auto continuous variable load sensing device.

It is also possible to achieve higher braking effort by increasing BP regime pressure. When the BP is set a 6 kg/cm², the corresponding brake cylinder pressure will rise to about

4.7 kg/ cm². Such higher brake effort requirements would be applicable to special operating conditions such as descent down a gradient.

Note: For other details and operating principles, refer Maintenance manual supplied by the air brake system.

C₃W₂ Distributor Valve

General

The C₃W₂ distributor valve is basically a C₃W valve with the 'Empty load' function added to provide two ranges of brake cylinder pressure for a given BP pressure.

The C₃W₂ distributor valve works in conjunction with an external load sensing device which provide pneumatic signal depending on the 'Loaded' to 'Empty' condition. Based on the this signal, C₃W₂ distributor valve delivers maximum pressure of 3.8 kg/cm² ('Loaded' condition) or a lower pressure at 2.2 kg/cm² ('Empty condition'). In order to perform this addition function C₃W₂ distributor valve includes an additional portion sandwiched between the body and the bottom cover of C₃W Distributor valve.

Operating

- The brake does not apply with a brake pipe drop of approximately 0.5 kg/ cm² in one minute.
- In "running" position, with the brake pipe at 5 kg/cm², the distributor valve is insensitive to a release kick of short duration.
- When the BP is dropped at the rate of 0.6 kg/cm² in 6 seconds, the brake commence to apply in 0.8 seconds.
- Maximum brake cylinder pressure will be 3.8 kg/cm² or 2.2 kg/cm² as the case may be, even in emergency condition.

- To facilitate faster release of brake, following a full service application, the brake pipe pressure can be increased to 6 kg/cm^2 without any risk of overcharging the control and auxiliary reservoir for a specified period of time.
- The brake is released and the distributor valve is re-set when the brake pipe pressure is approximately 4.83 kg/cm^2 .
- All other characteristics of C3W distributor valve also remain the same.

Note: For other details and operating principles refer Maintenance Manual supplied by the air brake manufacturer.

KEO Distributor Valve

Operating Features

The KEO Distributor Valve consists of the following main subassemblies:

a) Three Pressure Valve

The three pressure valve controls the charging and discharging of the brake cylinder in accordance with the pressure changes in the main brake pipe. It responds to the slightest variations of the control pressures.

b) U- Controller with U-Chamber

At the start of an application, via U-controller air is tapped off from the brake pipe, thus causing an initial pressure reduction and ensuring simultaneous rapid propagation of the braking impulse throughout the train.

c) Minimum Pressure Limiter

When application is initiated, the minimum pressure limiter causes rapid charging of the brake cylinder up to a determined pressure to overcome rigging resistance.

d) Maximum Pressure Limiter

The maximum pressure limiter works independently of supply air reservoir pressure and time. The air reservoir pressure can exceed the standard operating pressure without causing the brake cylinder pressure to rise above its permissible maximum value. Consequently, there is no change in application and release timing. In addition, the cylinder pressure is independent of the stroke. Leakages in the brake cylinder pipes can be effectively compensated by increasing the air reserve in the auxiliary reservoir.

e) Choke Cover

The choke cover contains application and release chokes for regulating the application and release times. It is mounted with four screws on the KE valve body.

f) Quick Release Valve AL V9a

The quick release valve allows the brake of the wagon to be fully released by means of a brief pull of the release handle without any loss of air in the auxiliary reservoir. The brake thus remains ready for reapplication. The quick release valve is assembled in the bottom cover and bottom cover is mounted on the basic valve body of the distributor valve.

g) A- Controller

A- Controller controls and isolates the control pressure. It also protects the control chamber from over charging.

h) R- Charger

The supply auxiliary reservoir is filled with air from the brake pipe by the R-charger. The auxiliary reservoir is separated from the brake pipe by a check-valve incorporated in the R-charger.

i) Isolating Valve

By means of the isolating valve the brake of each wagon can be switched “on” and “off” and in the letter case it is fully vented.

NOTE:- For other details and operating principle refer Maintenance Manual supplied by the air brake manufacture.

j) Pressure Transformer DU 111 A

General

This device is attached to the basic KEO distributor valve for application on wagons where automatic two stage load braking is required.

KEO Distributor valve with pressure transformer DU 111 A works in conjunction with an external load sensing device which provides a pneumatic signal depending on the 'loaded' or 'empty' condition. Based on this signal, the distributor valves deliver maximum pressure of 3.8 kg/cm² ('loaded' condition) or a lower pressure of 2.2 kg/cm² ('empty' condition).

Operation

Compressed air from auxiliary reservoir enters into the operating valve through Tee with choke and flexible hoses with adapter. Another flexible hose with adapter is connected between EL port of distributor valve and operating valve. The operating valve remains closed in 'EMPTY' condition. Thus no pneumatic signal is passed on via EL port to the pressure transformer which contains the maximum brake cylinder pressure of 2.2 ± 0.25 kg/cm². In loaded condition the operating valve lets the compressed air signal to EL port of distributor valve pipe bracket and the transformer gets the pneumatic command and the brake system gets adjusted to a maximum brake cylinder pressure of 3.8 kg/cm².

NOTE:- For maintenance details and operating principles refer OEM Manuals and of air brake manufacturer.

2.2 COMMON PIPE BRACKET

Common pipe bracket is permanently mounted on the under frame of a vehicle. The distributor valve along with the

intermediate piece (sandwich) which houses the isolating cock is mounted on one face of the common pipe bracket. The control reservoir is mounted on the other face of the Common pipe bracket.

The Common pipe bracket has been evolved with the purpose of making it suitable for use with any make of distributor valve adopted on Indian Railways.

Common pipe bracket is a sturdy casting with internal air passages, matching the intermediate piece mounting face with accurately profiled air cavities and flanged ports leading to the appropriate ports of the distributor valve.

Branch pipes to the brake pipe and brake cylinders are fitted on the appropriate ports on the common pipe bracket. The advantage of fitting a common pipe bracket is to remove the distributor valve for repair or replacement without disturbing the pipe connections.

2.3 INTERMEDIATE PIECE (SANDWICH PIECE)

Intermediate piece serves the purpose of blanking all the other ports on the common pipe bracket front face other than required for a particular make of distributor valve. Each type of distributor valve is mounted on the common pipe bracket with its own intermediate piece (sandwich).

Intermediate piece is mounted on the common pipe bracket face with a common gasket and the distributor valve is fastened to the intermediate piece. Isolating cock for distributor valve, which is housed in the intermediate piece is for isolating the distributor valve in case of malfunctioning or for disconnecting the brake pipe pressure. Isolating cock on intermediate piece has a built in venting arrangement.

2.4 BRAKE PIPE & FEED PIPE HOSES

In order to connect two successive wagons fitted with Single pipe/ Twin Pipe, the brake pipes (BP) and feed pipe installed on the underframe are fitted with flexible hoses. The hoses are named as BP hose and FP hose.

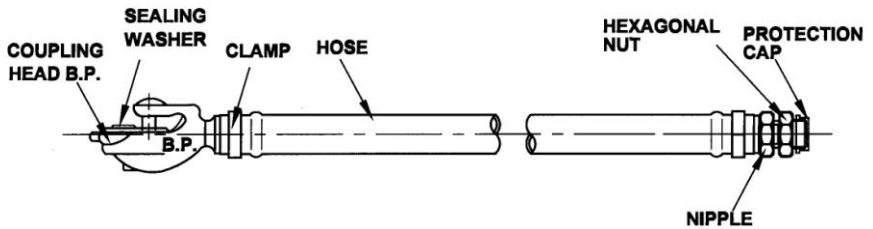

FIG. 12. BRAKE PIPE HOSE

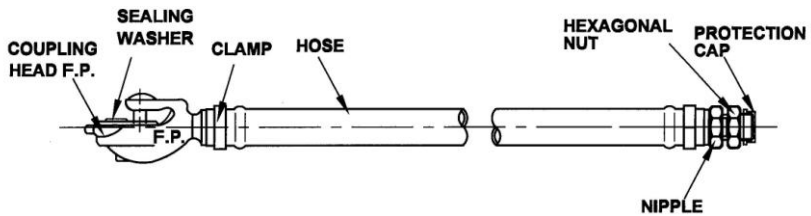

FIG. 11. FEED PIPE HOSE

2.5 BRAKE PIPE & FEED PIPE COUPLING

To connect subsequent wagons, the hoses of BP and FP are screwed to coupling and hose nipple by means of stainless steel Bend ‘U’ type clips. The coupling is specially designed

in the form of palm end and hence also known as palm end coupling. For easy identification the couplings are engraved with letter BP & FP and coupling heads are painted green for BP and White for FP.

Note: Design, controlling dimensions, material and specification of components shall conform to the latest revision of RDSO drawings.

The air brake hose couplings are provided in the brake pipe line and feed pipe line throughout the train for connecting the brake pipe and feed pipe of adjacent wagons to form the complete rake. Each Air Brake Hose coupling consists of a specially manufactured rubber hose clamped over a nipple on one end and a coupling head on the other end. Rubber sealing washers are provided on the outlet port of the coupling head.

Since a joint is formed at the coupling head, leakage may take place, through it. Therefore it is necessary to subject the hose coupling of brake pipe to leakage test.

Test Equipment

Test stand

Test stand for testing of the hose coupling consists of the following main equipment

- 1) Supply of compressed air at – 10 Kg/cm²
- 2) Isolating cock – 1a and 1b
- 3) Exhaust cock – 1c
- 4) Main reservoir
- 5) Pressure gauge
 - 6a for main reservoir
 - 6b for flexible hose
- 6) Flexible hose - for connecting hose coupling for immersing in to water.
- 7) Water tub with safety cage – for checking leakage

- from hose coupling.
8) Dummy coupling head.

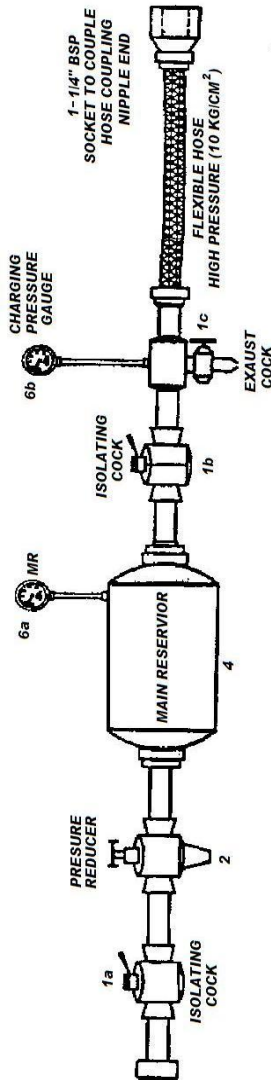

FIG. 13. TEST STAND FOR HOSE COUPLING

Test Procedure

For testing the hose coupling the steps given below should be followed:

- 1) Use a dummy coupling head to block the outlet port of the hose coupling.
- 2) Connect to hose coupling under test to the end of flexible hose.
- 3) Open isolating cock 1(a)
- 4) Adjust pressure regulator (2) so that pressure gauge (6a) shows 10Kg./cm² air pressure.
- 5) Immerse the hose coupling assembly completely in the tub of water.
- 6) Open isolating cock (1b) and see that (6b) shows 10 Kg/cm² pressure.
- 7) Observe leakage, if any from all parts of the hose coupling.
- 8) Close the isolating cock 1(b).
- 9) Disconnect the hose coupling from test bed.
- 10) If the leakage is observed through the coupling head, replace the gasket and test again.
- 11) If leakage persists even after change of gasket the coupling head is unserviceable and complete assembly shall be rejected. However if leakage occurs at the hose nipple or coupling end hose joint the clamp should be attended/replaced to make the assembly leak proof.

Safety Precautions

- Specified tools and fixtures should be used for connecting and disconnecting the hose coupling with the air supply.
- While testing the hose coupling before charging it to 10kg/cm² pressure, the tube should be covered and locked with a protective cage.

- Exhaust the pressure from the hose coupling under test, before lifting the safety cage and uncoupling it.
- After testing, the hose assembly shall be stored in a dry and clean space. The inlet and outlet port must be plugged with protective cap to prevent entry of dust and foreign particles inside the hose coupling.

2.6 CUT OFF ANGLE COCK

Cut off angle cocks are provided on the air brake system to facilitate coupling and uncoupling of air hoses (i.e. brake pipe). When the handle of the cut off angle cock is placed in closed position it cuts off the passage of compressed air, there by facilitating coupling and uncoupling action.

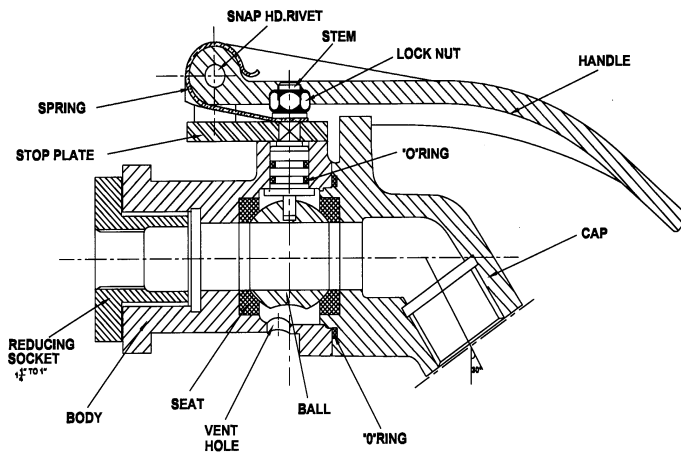

FIG. 14. CUT OF ANGLE COCK

If coupling action has to be performed on a given rake, ensure that the cut off angle cock provided at the end of the

brake pipes are closed. By doing this the compressed air gets cut off and does not enter into the brake pipe air hose . The air hoses without compressed air can thus easily be coupled without any jerk. Similarly during uncoupling the cut off angle cocks of subsequent wagons should be closed. By doing so the air present in the brake pipe air hose gets leaked through the vent provided in the body of the cut off angle cock. Finally the air hoses get emptied and thus can be easily uncoupled without any jerk.

The cut off angle cock consists of two parts viz. cap and body which are secured together by bolts. The cap and the body together hold firmly the steel ball inside it, which is seated on rubber seat. The ball has a special profile with the provision of a groove at the bottom portion for venting the air to the atmosphere.

On the top surface of the body a bore is provided for placing the stem, to which a self locking type handle is fixed. When the handle is placed parallel to the cut off angle cock the inlet port of the cut off angle cock body is connected to the outlet port, through the hole provided in steel ball. Thus air can easily pass through the cock. This position of the handle is known as open position. When the handle is placed perpendicular to the cock body the steel ball gets rotated and the spherical and groove portion of the ball presses against the sealing ring at inlet and outlet port, there by closing the passage of inlet air and venting the outlet air through the vent hole. This position of the handle is known as closed position.

With the stem one leaf spring is provided which presses the operating handle downwards. By virtue of this, handle gets

seated in deep grooves at ON/OFF position resulting in a mechanical lock.

Under normal working conditions, the handle of all cut off angle cock of BP are kept open except the rear end angle cock (BP). This facilitates in charging the complete air brake system with compressed air supplied by the compressor housed in the locomotive. Cut off angle cock fitted on the brake pipe is painted green.

Note: The dimension and tolerances of cut off angle cock shall be as indicated in latest revision of RDSO drawing nos. WD-88123-S-01 and WD-88123-S-02.

Since a number of manufacturers exist for air brake equipment and component, refer to concerned original manufacturer's maintenance manual for part no. and description of spares.

Overhauling of Cut Off Angle Cock

These angle cocks are of ball-type ensuring better sealing against leakage and facilitate ease of operation. During overhauling, it is dismantled for cleaning, replacement of parts and checking for effective functioning.

The cut-off angle cock is to be completely dismantled and overhauled during POH or when there is some specific trouble.

Tools & Equipments

The following tools and fixtures are required for overhauling

- i. Single end spanner.

- a. A/F 17 for M10 nut pivot screw.
- b. A/F 10 for M6 nut.
- ii. Screw driver 12"/300 mm long.
- iii. Vice with soft lining.
- iv. Light hammer.

Procedure

Dismantling

- Hold the cut – off angle cock in vice.
- Unscrew the lock nut from the stem.
- Take out the handle assembly (The handle assembly need not be dismantled further unless it is necessary to change the plate spring i.e. if it is found, heavily rusted, pitting crack or the spring is permanent set).
- Unscrew the four hexagonal bolts and spring washers.
- Detach cap from the body.
- Remove ‘O’ ring and ball seat from the cap.
- Turn the stem in such a way that the ball can be pulled from the stem.
- Slightly hammer the stem at its top and take out the stem through the bore of the body.
- Remove the ball seat from the body.

Cleaning of Parts

- Clean out side portion of the body and cap with wire brush.
- Direct a jet of air to remove the dust.
- Clean all metallic parts with kerosene oil and wipe dry.

Replacement of Parts

- Replace all rubber parts.
- Replace spring-washer, nut & bolts in case they are excessively corroded or defective.
- Replace handle spring if it is found heavily rusted, is having pitting crack or is permanently set (Dismantle the handle assembly, and fit a new spring along with a snap head rivet).

- Replace stainless steel ball if found with scratch marks on the outer surface or dented.

Assembly

- Insert the two ‘O’ rings in their respective grooves on the stem.
- Keeping the threaded end of the stem first, insert the stem into the body through the bore of the body.
- Place one ball seat in its groove inside the body.
- Position the ball after correctly aligning its venting slot in the bore of the body.
- Place the second ball seat and ‘O’ ring in their respective positions on the cap.
- Secure the body and cap by Hex. Hd. Bolt (M6) and spring washer (for M6).
- Place the handle assembly on the stem and secure it with Hex. Hd. Nut (M10).
- During assembly apply a light coat of shell MP2 or equivalent grease on the external surface of the threads and the ball.

Testing of Cut–Off Angle Cock

Tools and Equipment

- i. Test Bench
- ii. Compressor to build pressure more than 10 kg/cm².
- iii. Single ended spanner as per IS 2027
 - a) Across face 17 (for M10 lock nut) - 1 No.
 - b) Across Face 13 (for M8 studs) 2 No.
- iv. Screw Driver –300mm, 1 No.
- v. 1 ¼” BSP dummy Plug with seal.
- vi. Dummy plug for angle cock.

Test Procedure

Following test procedure should be adopted step by step for performing the leakage test.

- i. Mount the angle cock on the base of the test bench (Part No. 7 of the figure of the test bench).
- ii. Move the handle to the closed position.
- iii. See that cock (1e) and (1c) are in closed position.
- iv. Now open cock 1(a) and 1(b) till MR indicates a pressure of 10 Kg/Cm².
- v. If necessary, adjust pressure regulator (2) to maintain the pressure at 10 kg/Cm².
- vi. Open cock (1c) and check the leakage with soap solution. There should not be any leakage.
- vii. Check pressure drop in gauge (6b) there should not be any leakage from flange joints, vent and outlet port of the angle cock.
- viii. Close cock (1c) and tighten the dummy plug and seal the outlet of the angle cock.
- ix. Move the handle to open position. Open cock 1c.
- x. Check for leakage from body and cap joint, vent and all over the stem periphery using soap water. No leakage is permissible.
- xi. Move the handle to closed position and notice a short blast of air through the vent.
- xii. Close cock 1c then Open cock (1d) and exhaust the pressure to zero.
- xiii. Remove the angle cock.
- xiv. Report results of the test.

Safety Precautions

- Specified tools and fixtures should be used for assembly and disassembly operations.
- The small metal parts like leaf spring, nut, bolts, washers, screws etc should be kept in a safe place and replaced in case found defective.
- Inlet and outlet port of the tested angle cock should be plugged with protection cap to prevent entry of dust and moisture inside the cut off angle cock.

- Ball should be handled carefully to avoid any damage on its surface.
- Threaded portion of body and cap should not be damaged at the time of dismantling.

2.7 BRAKE CYLINDER

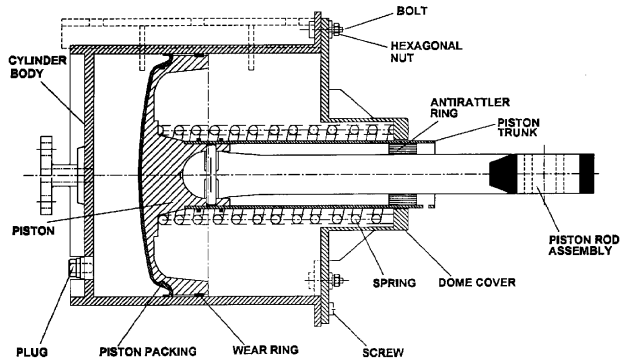

Note: Anti-rattler ring shall be provided on brake cylinder for passenger stock

FIG. 15. BRAKE CYLINDER

On every wagon fitted with air brake system one brake cylinder is provided for actuating the brake rigging for the application and release of brakes.

During application stage the brake cylinder receives pneumatic pressure from the auxiliary reservoir after being regulated by the distributor valve. There after the brake cylinder develops mechanical brake power by outward movement of its piston assembly. To transmit this power to the brake shoe, the push rod of piston assembly is connected to the brake shoe through a system of levers to amplify and transmit the brake power. During release action of brakes the

compression spring provided in the brake cylinder brings back the rigging to its original position.

The cylinder body is made out of sheet metal or cast iron and carries the mounting bracket, air inlet connection, ribs and flange. To the cylinder body, a dome cover is fitted with the help of bolts and nuts. The dome cover encloses the spring and the passage for the piston trunk, which is connected to the piston by screws. The piston is of cast iron having a groove in which piston packing is seated. Piston packing of rubber material which is of oil and abrasion resistant and unaffected by climatic changes. It is snap fit to the piston head and has self lubricating characteristic which ensures adequate lubrication over a long service period and extends seal life considerably

The piston packing also seals the air- flow from the pressure side to the other side and is guided by the wear ring. The wear ring prevents the friction between cylinder body and the piston head. The piston sub assembly incorporates a push rod, which can articulate and take minor variations in alignment during fitment/operation.

Note: The dimension and tolerances of brake cylinder shall conform to the latest revision of RDSO drawing number WD-92051-S 06, WD-92051-S-07, WD-92051-S-08, WD-92057-S-09, WD 92051 –S-09, WD 94048-s-01, WD 92051 –S-11, WD 92051 –S-12, WD 92051 –S-13, WD 92051 –S-14 and WD 92051 –S-15.

Overhauling of Brake Cylinder

Brake cylinder has to be thoroughly overhauled for efficient and reliable trouble free performance during its prolonged

service life. The complete overhauling of the brake cylinder is to be carried out during POH or when there is some specific trouble.

Tools & Equipment

S.N.	Description
1	Torque Wrench 0-3 Kg range
2	Double End Spanner 24x27 mm across face (For M16)
3	Double End Spanner across face 13x14 (For M12)
4	Socket Wrench 19 mm (For M12)
5	Screw Driver 12" (300 mm)
6	Special fixture (Screw press/ Pneumatic)
7	Gauge for examining bore of the cylinder

Dismantling of Brake Cylinder

Before dismantling the dome cover insert a rounded head pin of 12x25 long and secure one of the hole in the piston trunk for the purpose of safety to prevent dome cover working out of the piston rod due to the cylinder return spring force while opening the dome cover with the help of a special fixture clamp the dome cover.

- Unscrew the Hex. Hd. nut and take out the spring washer on the dome cover.
- Turn the handle of the fixture to release the clamp and withdraw the holding clamp of the fixture till the return spring inside the cylinder is fully expanded and free.
- Remove the dome cover and take out the return spring.
- Remove the bush on the rod and brake cylinder.
- Remove the piston rod sub-assembly, piston ring packing, wear ring and slide out the anti rattler ring from the piston rod.

- Unscrew the CSK, head screw and separate the piston, pin, piston trunk & piston rod assembly.
- Unscrew the brake cylinder plug at the rear end.

Cleaning of Parts

- Blow a jet of air to clean the dust on the external surface.
- Clean the metallic parts using wire brush and kerosene oil.
- Clean the internal parts with nylon bristle brush.
- Clean piston packing, wear ring and rubber parts with soap water solution.

Replacement of Parts

- Replace return spring in case of crack, kinks or permanent set.
- Replace the brake cylinder body if found with deep marks, heavily corroded, or the bore is worn uneven or having ovality.
- Replace all rubber parts.
- If piston trunk is worn excessively it should be replaced.
- Replace piston and piston rod for damages, bent etc.
- Replace dome cover for damage, damaged hole etc.

Inspection and Repairs of the Parts

- Examine visually that the internal surface is free from scratches, rust.
- Brake cylinder bore to be checked for ovalness with proper gauge.
- Check the characteristics of the return spring.
- Piston trunk to be checked for wear and tear.
- Pin, piston rod should be checked for wear.
- Dome cover shall be checked for excessive wear and if worn build up with welding and thereafter re-bore to the required size.
- Gauge bush bore of the piston rod, replace it if worn.

Testing Of Brake Cylinder Body for Leakage

Before assembly, put dummy plate on the dome side and subject the brake cylinder for hydraulic pressure of 10 kg/cm² for 5 minutes. No leakage is permitted.

Assembly of Brake Cylinder

- Assemble piston rod, pin, and piston trunk on piston, tighten CSK screws to piston trunk and piston.
- Slide anti-rattler ring from the piston front side.
- Assemble piston return spring on the piston head and insert the dome cover over the piston trunk.
- Insert ϕ 12 x 25 mm long head pin into the hole provided in the extended portion of the trunk.
- Smear the piston head & inside the cylinder body with MP 2 grease or equivalent.
- Ease the packing into the cylinder with a wooden spatula with a round nose and round edge to avoid damage to the piston packing.
- Push the piston assembly approximately to the central position of the cylinder.
- With the help of special fixture, bring down the dome cover on to the cylinder body and fasten the 8 Hex. HD bolt, nut and spring washer with required torque.
- Take out the ϕ 12x25 long pin from the piston trunk hole.
- Fit back the plug at the rear of the cylinder.
- Fit the new piston packing and wear ring.

Testing of Brake Cylinder

Brake Cylinder Test Bench

Test bench consists of the following main parts

- i. 3 nos. of isolating cocks
- ii. Isolating cock with 1mm choke

- iii. Pressure reducing valve
- iv. 2 Nos. Pressure gauges
- v. Pipe line filter
- vi. Brake cylinder pressure mounting base with safety guard
- vii. Air reservoir

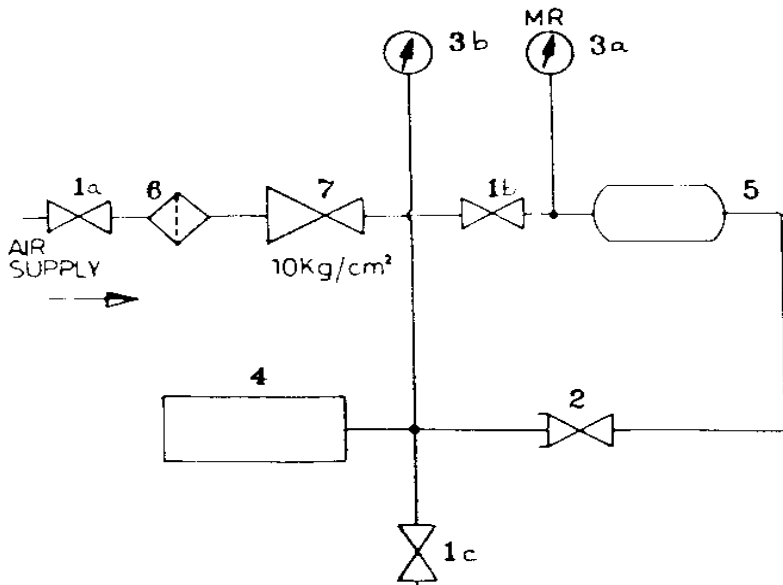

FIG. 16. TEST BENCH FOR BRAKE CYLINDER

Tools Required During Testing

- i. Torque wrench range (2-3 kgM capacity).
- ii. Double ended spanner (M16) 24x27.
- iii. Socket wrench (M12) across face 19.
- iv. Double ended spanner (M8) across face 13x14
- v. Screw Driver – 300mm.

After the overhauling of the brake cylinder, it is mounted on the test bench and tested. It should be operated a few times on the test bench to ease the piston. Each brake cylinder after its maintenance and overhaul shall be subjected to the following tests on the test bench.

Arrangement as shown in Fig. 8.9 is used for testing.

Strength Test

Follow the procedure as given below.

- i. Place the brake cylinder on base (4) and connect the line to brake cylinder. Brake cylinder stroke should be free.
- ii. Close the safety guard, close the cock (1c).
- iii. Open cock (1b) and let reservoir pressure reach 10 Kg/cm². Check the pressure in MR gauge (3a).
- iv. Open cock (2) till the pressure reaches 6 Kg/cm² in pressure gauge (3b).
- v. Close the cock (2) and wait for 2 minutes.
- vi. Open cock (1c).

The above test should be done with the safety guard.

Pressure Tightness Test

Follow the following procedure.

- i. Mount the cylinder on the test stand and tighten the mounting bolts & nuts.
- ii. Set the brake cylinder stroke at 85 ± 10 mm.
- iii. Open cock (2) and let the pressure gauge (3b) reaches 0.8 Kg/cm².
- iv. Close the cock (2) and wait for 1 minute till the pressure stabilize in gauge (3b).
- v. Check for the pressure drop which should not be more

than 0.1 Kg/cm^2 in 10 minutes.

- vi. Open cock (1 c)
- vii. Repeat the test at $130 + 10 \text{ mm}$ piston stroke and 3.8 Kg/cm^2 pressure. Close cock (2) open cock (1c). Remove the brake cylinder.

If pressure is not correct or leakage rate is higher, dismantle the brake cylinder and examine piston packing wear ring for proper fitment. Examine plug for leakage. Reassemble the components and retest.

Painting

The exterior of the brake cylinder shall be painted with black enamel paint.

Storing

- Assembled or dismantled brake cylinder should be stored in such a way to prevent the following.
- Flange surface should be prevented from damages.
- Inlet and outlet port should be plugged with protective cap to prevent the entry of dust and moisture inside the brake cylinder.

Precautions During Testing

- Safety Guard should be used during the strength test.
- Assembled or dismantled brake cylinder should be stored in such a way to prevent the following:
 - i. Flange surface should be prevented from damage.
 - ii. Inlet port should be plugged with a protective cap to prevent the entry of dust and moisture inside the brake cylinder.

- Avoid damage to piston packing by dull or sharp edged thin bladed tool.
- Fit 12 dia, 25 mm long round headed pin on the hole provided in the extended portion of trunk surface before loosening the cover bolts.
- Excessive lubrication of the cylinder must be avoided.
- Specified tools and fixtures should be used for handling, mounting and removing the brake cylinder from the test bench.
- The small metal parts like springs, washer, screws, nuts, bolts, washers should be kept in a safe place and replaced in case found defective.

2.8 DIRT COLLECTOR

Function of Dirt Collector

Dirt Collector is placed in the brake pipe line at a point from where a branch is taken off to the distributor valve. As the name indicates the purpose of the dirt collector is to protect the distributor valve and the auxiliary reservoir by trapping dust and other foreign matters from the compressed air before it enters into the distributor valve and the auxiliary reservoir. This action is achieved by centrifugal action. Hence it is also known as centrifugal dirt collector. The dirt collector ensures inter vehicular full flow of dirt free compressed air to the auxiliary reservoir and the distributor valve through the branch pipes. When the air enters into the body of the dirt collector tangentially through port 'A' it passes down through inverted case in a spiral path. Due to the velocity of air flow, dirt particles get flung

outwards. There after they slide down & collect at the bottom.

Features of Dirt Collector

The air entering into the dirt collector from the brakepipe is guided through suitably shaped passage in dirt collector body to produce centrifugal flow. The air is then filtered through additional filter assembly before it is passed to outlet on branch pipe side to provide dust proof air to the distributor valve /auxiliary reservoir after arresting fine dust particles. The dirt contained in the air descends down and gets deposited in the dirt chamber. However, fine particles are also arrested in the filter assembly. The dust particles accumulated in the dirt chamber are removed by opening the drain plug. Rubber gasket is provided between the cover and housing to prevent leakage. Similarly leather washer is provided between the housing and the drain plug to prevent leakage.

Note: The dimensions and tolerance of dirt collector shall be as indicated in latest revision of RDSO drawing number WD-92051-S-03, WD-92051-S-04 and WD-92051-S-05.

The dirt collector is to be completely dismantled and overhauled once in 5 years or after 8 lakhs kilometers whichever is earlier or when there is some specific trouble.

Tools & Fixtures

The following tools and fixtures are required for overhauling:

- Spanner 19 x 22mm
- Vice
- Screw Driver

Procedure for Maintenance

I. Disassembly

- Hold the dirt collector in vice.
- Loosen drain plug and remove it completely from housing.
- Remove top cover and seal by loosening four hexagonal nuts and removing hexagonal bolts.
- Remove filter from body.

II. Cleaning of Parts

- Clean all metallic parts using brush and kerosene oil.
- Clean filter with soap water.
- Check all parts for any damage.

III. Parts replacement

- Replace sealing ring and gasket.
- Replace filter if found punctured or damaged.
- Check spring washer and replace in case defective or excessively corroded.

IV. Assembly

- Assemble body after smearing grease.
- Locate filter in position and assemble top cover with new gasket.
- Fix hexagonal bolts/nuts along with the spring washer.
- Fix new sealing ring to the bottom and assemble drain plug.

Testing of Dirt Collector

Centrifugal Dirt Collector is provided at the junction of the main pipe and branch pipe in brake pipes. There are three purposes for providing the dirt collector.

- i. To ensure inter-vehicular full flow of brake pipe lines.
- ii. For branching and feeding to the distributor valve.
- iii. To remove dust and scale particles from the air prior to entering the distributor valve and the air reservoir.

As Dirt collector is subjected to high air pressure it has to be tested for the leakage and strength. Testing of dirt collector is needed after its overhauling. There may be various causes due to which overhauling and subsequent testing of the dirt collector is required.

Tools & Equipment

- Test Bench
- Compressor, capable of building air pressure up to 10 kg/sq. cm.
- Double ended spanner (Across Face 19x22).
- Dummy flange for dirt collector.

Test Procedure

Each dirt collector after overhauling and maintenance should be subjected to pressure test as below:

- Mount the dirt collector on base of the test bench.
- Keep cocks (1f), (1c) and 1(e) closed.
- Open cock (1a) and (1b).
- Charge the reservoir (5) to 10 kg/cm².
- Close two openings on the dirt collector using dummy flanges.
- Open cock (1e), check the pressure at (6c). It should be equal to 10 kg/sq. cm.
- If not develop pressure up to 10 kg/cm² by adjusting pressure regulator(2).
- Close cock (1e)

- Check for leak over the body and joints with the help of soap solution, no leak is permitted.
- Also check for pressure drop in gauge 6(c)- for 3 minutes
- Pressure in the gauge 6c should be maintained.
- Reduce the pressure in the main reservoir (5) to 5 kg/cm² by opening cock (1f) and adjusting the pressure regulator (2).
- Close cock (1f) as soon as pressure reaches up to 5 kg/cm².
- Remove the dummy flange from the outlet port (which feeds to the distributor valve).
- Check for free flow of air from the outlet port. (If air is not flowing freely it means that the filter is choked).
- The pressure will soon exhaust through the outlet port.
- Remove the dirt collector from the test stand.
- Report Results.

Safety Precautions

- The assembled dirt collector should be stored in such a way to prevent the following:
- Flange surface should be prevented from damage.
- Inlet and outlet port should be plugged with protective caps to prevent the entry of moisture and dirt inside the dirt collector.
- Specified tools and fixtures should be used for handling, mounting and removing the dirt collector from the test bench.
- The small metal parts like screws, nuts, bolts, washers etc. should be kept in a safe place and replaced in case found defective.

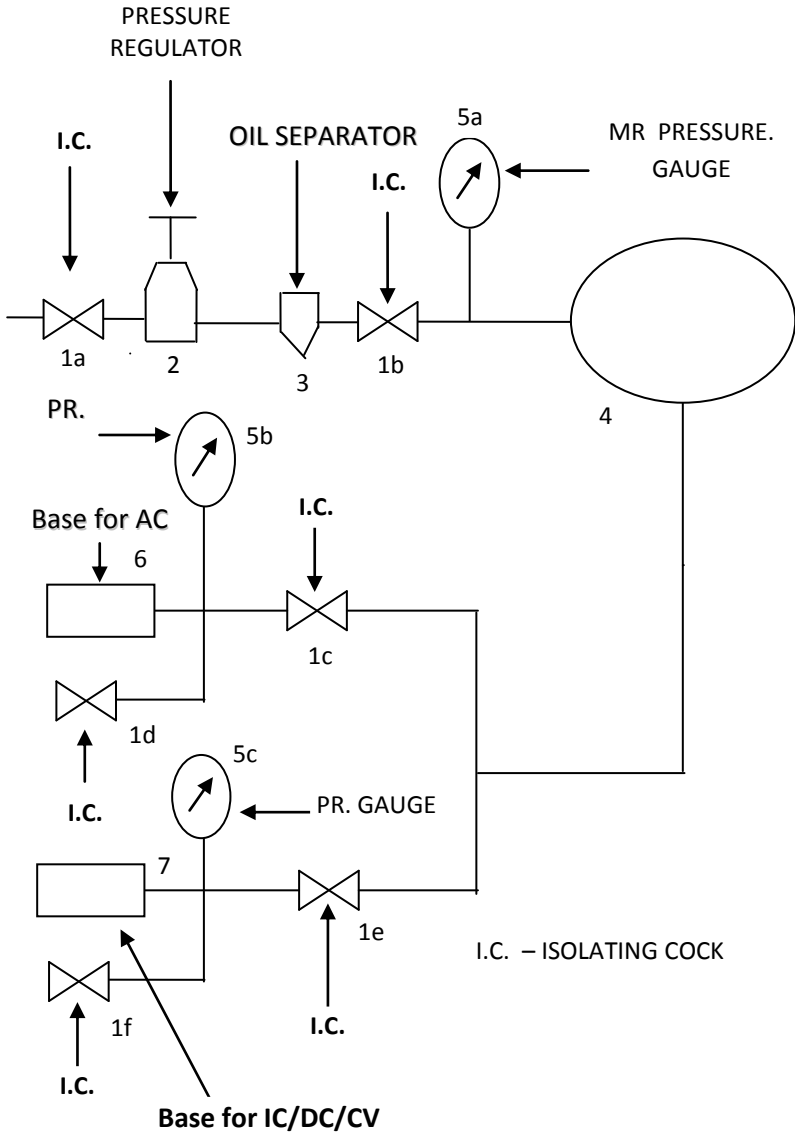

FIG. 17. TEST BENCH FOR ANGLE COCK & DIRT COLLECTOR

2.9 AUXILIARY RESERVOIR

Function

Auxiliary reservoir is actually a pressure vessel and its function is to feed dry compressed air to the brake cylinder for application of brakes.

Salient Features

The auxiliary reservoir is a cylindrical vessel made of sheet metal. On both the ends of the reservoir, flanges are provided for pipe connection. One end of the auxiliary reservoir is connected to the brake pipe through the distributor valve. Auxiliary reservoir is charged through the brake pipe. The auxiliary reservoir is charged to 5kg/cm^2 pressure, charging from the brake pipe through Distributor valve.

At the bottom of the auxiliary reservoir, drain plug (or drain cock) is provided for draining out the condensate/moisture.

Note: The dimension & tolerances of the auxiliary reservoir shall be as indicated in latest revision of RDSO drawing WD-92051-S-01 for 100 lit. Capacity and RDSO drawing number WD-92051-S-02 for 75 lit. capacity.

The auxiliary reservoir is to be completely dismantled and overhauled during POH or if there is some specific trouble.

Tools & Equipment

- Spanner A/F 19x22
- Light hammer

Procedure for maintenance

Dismantling

- Unscrew the drain plug or drain cock.
- Drain the water accumulated in the tank.

Cleaning of Parts

- Examine the outer surface for any pitting scales or rusting.
- Clean the exterior of the auxiliary reservoir with a wire brush.
- Pour kerosene oil in to the auxiliary reservoir and roll few times and drain the oil.
- Dry the interior of the reservoir with a jet of air.
- Rinse the reservoir with RUSTO-LINE and then with ESSO-RUST 392 or equivalent.
- Clean the drain plug with a wire brush.
- Auxiliary reservoir shall be painted on the exterior with two coats of zinc chromium primer and two coats of black enamel.

Replacement of Parts

- Replace the plug washer.
- Replace the plug if threads are rusted or damaged.
- Replace the reservoir having deep cuts on surface.

Assembly

Assemble the drain plug with washer by screwing it back into its position.

Testing of Auxiliary Reservoir

Air Pressure Test

- Block one side passage of the auxiliary reservoir with dummy flange.
- Admit air pressure from the other side passage at 10 Kg/cm².
- Check the leakage at the weld seams, with soap water solution.
- No leakage is permitted.

Hydraulic Test

- With a hydraulic pump, apply a pressure of 16 Kg./cm² from one flange end after blocking the opposite end.
- Hold the pressure for 5 minutes.
- Check for the leakage on the external surface of the reservoir by gently tapping on the weld seams with a light hammer.
- No leakage is permitted.
- Drain out the water completely and allow the reservoir to dry, by directing a jet of air.

Safety Precautions

- Specified tools and fixtures should be used for assembly and dismantling operations.
- Rubber / leather components should be stored in a safe place away from heat, alcohol & acids. All metal parts like washers should be kept in a safe place.

2.10 GUARD'S EMERGENCY BRAKE VALVE

Guard's emergency brake valve is provided in the guard's compartment. This valve provides a facility to the guard to initiate brake application in case of any emergency.

Guard's emergency brake valve is connected to the brake pipe. This valve is actually placed in the guard's compartment so that in case of an emergency, the guard of the train can communicate to the driver of the train by operating the valve provided in the brake van. When the handle of the guard's emergency brake valve is placed parallel to the pipe, the air from the brake pipe is exhausted to the atmosphere. However, to restrict the excessive drop of air pressure in the brake pipe, a choke of 5mm is provided in this valve. This drop in pressure in the brake pipe can also be observed in the air flow meter provided in the locomotive cabin and finally the driver applies the brakes for stopping the train. The handle of the guard's emergency brake valve has to be reset manually to normal position before the brake pipe pressure is to be recharged.

Salient Features

The guard's emergency brake valve consists of a housing in which a ball is housed. The ball has a through hole similar to the isolating cock. To the ball a handle is fixed at the top. By operating the handle the ball can be rotated along the vertical axis. When the hole in the ball gets aligned with the inlet and the exhaust port the compressed air can pass through the valve. However, for restricting the flow of air a choke of 5mm is fitted in the exhaust port for controlling the rate of

BP exhaust. In order to have leak proof assembly two rubber seats are also provided in the guard's emergency brake valve

Note: The general design and controlling dimension of guard's emergency valve shall conform to the latest revision of RDSO drawing no SK-73549, 97030.

The guard's emergency brake valve should be completely dismantled and overhauled during POH or when there is some specific trouble.

Tools & Fixtures

The following tools and fixtures are required for overhauling-

- Spanner A/F 19/22.
- Special spanner for removing thread plug.
- Spanner for removing gland.
- Light hammer
- Vice.

Procedure for Maintenance

Dismantling

- Hold the valve in the vice.
- Unscrew the nut on the stem and remove the nut and the spring washer.
- Remove the handle.
- Unscrew the gland and pull out the stem from the body.
- Remove the two gland packing on the stems.
- Unscrew the threaded plug from the body using a special spanner.
- Remove the 'O' ring and the ball seat from the body.
- Remove the ball and the second ball seat from the body.

Cleaning of Parts

- Direct a jet of air on the valve body to remove the dust & dirt.
- Clean the external parts of the valve with wire brush.
- All metal parts shall be washed with kerosene oil and wiped dry.
- Rubber parts shall be washed with soap water solution.
- Steel ball shall be handled carefully to avoid scratch marks or dent.

Replacement of Parts

- Replace all the rubber parts such as gland packing and 'O' ring.
- If spindle thread is corroded or damaged, the spindle shall be replaced with a new one.
- If threads on the threaded plug are damaged or corroded badly, the plug shall be replaced with a new one.
- If ball of the valve has dent or scratch marks it should be replaced with a new one.

Assembly

- Place seat ring in its position in the bore of the body on one side.
- Apply grease lightly on the ball.
- Fit 'O' rings on the spindle.
- Insert the ball in the bore of the body in such a way that the ball sits on the seat ring and the groove seat for spindle is in top position.
- Insert the spindle with 'O' rings such that the spindle enters in to the groove.
- Screw the gland in to the body.
- Insert the second seat ring through the bore of the housing.
- Fit 'O' ring on the threaded plug. With a special tool

screw the threaded plug.

- Screw the threaded plug along with the 'O' ring into the housing till the ball seat touches the ball.
- The handle shall be put on the spindle and tightened with spring washer and nut.

Testing

- After overhauling, fix the valve to the test bench.
- Put the handle of the valve in off position (close position).
- Charge the inlet port with a pressure of 10Kg./cm².
- Check for leakage on the spindle portion and on the exhaust port with soap water solution.
- No leakage is permitted.
- Operate guard's emergency brake valve, by putting the handle in open position. Air should escape through the vent of the valve.

2.11 QUICK COUPLING ARRANGEMENT

For fitment of gauge an arrangement for quick coupling is provided. The figure shows the arrangement. The quick coupling when assembled with and without plug shall be leak proof when tested up to 10 kg/cm^2 air pressure.

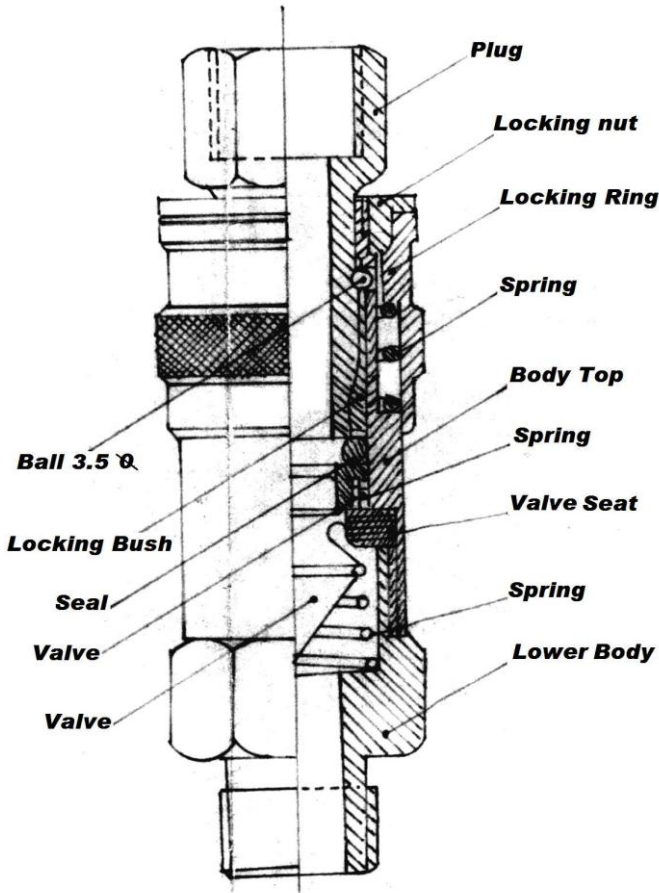

FIG. 18. QUICK COUPLING

2.12 SLACK ADJUSTER

Salient Features

Slack adjuster (also known as brake regulator) is a device provided in the brake rigging for automatic adjustment of clearance/slack between brake blocks and wheel. It is fitted into the brake rigging as a part of mechanical pull rod. The slack adjuster is double acting and rapid working i.e. it quickly adjusts too large or too small clearance to a predetermined value known as 'A' dimension. The slack adjuster maintains this 'A' dimension throughout its operation. The slack adjuster, type IRSA-600 & IRSA - 750 used on wagons is composed of the following parts

- Adjuster spindle with screw thread of quick pitch (non self locking)
- Traction unit containing adjuster nut, adjuster tube and adjuster ear etc.
- Leader nut unit containing leader nut and barrel etc.
- Control rod with head.

The outstanding features of slack adjuster IRSA-600 & IRSA - 750 are:

(I) Fully Automatic

Once initially set, no manual adjustment is further necessary at any time during its operation.

(II) Double-Acting

The brake shoe clearance is adjusted to its correct value both ways, either when it has become too large (owing to wear of the brake shoes and wheels) or when it has become too small (e.g. owing to renewal of 'worn out brake blocks').

(III) Rapid Working

Correct brake shoe clearance is automatically restored after one or two applications of the brake.

Verification

If resistance occurs early in the brake application, caused by heavy brake rigging, e.g. an ice coating on the brake shoes, etc., in such cases the IRSA does not pay out slack immediately, but indexes the amount of slack to be paid out. If the slack really is too small, the IRSA will pay out this indexed slack at the next brake application. Thus false pay-out will not occur.

True Slack Adjuster

The slack adjuster adjusts incorrect slack only, thus giving the brake its best possible pre-adjusted limit of piston strokes, ensuring a smooth and efficient braking force at all times.

Shock Resistant

Train shocks will not cause false take-up or pay-out of slack. When brakes are released, the moving parts of the slack adjuster are securely locked.

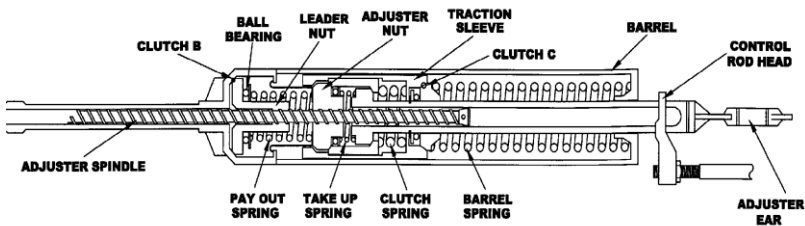

FIG. 19. SLACK ADJUSTER

Working Principle

In slack adjuster the 'A' dimension is the controlling feature. 'A' dimension is the distance measured between the control rod head and the barrel when the brakes are fully released. In other words 'A' dimension corresponds to the correct slack when brakes are fully released. For wagons it defers wagon to wagon and 'e' dimension which is the limit of length that adjuster will adjust is 555 - 575mm other than higher axle load wagons ('A' and 'e' dimension should be maintained under all working conditions). For effective operation, slack adjuster has to operate under three different conditions, i.e. with:-

- Correct slack
- Too large slack
- Too small slack.

Overhauling of slack adjuster

Tools & Equipment

The following tools and fixture are required for overhauling of slack adjuster;

1. Jacking tool – for mass repair / overhauling of Slack Adjuster pneumatically operated fixture is used.
2. Special Spanner
3. Straight Nose plier (external) (spring type) 18 mm to 25 mm - external
4. Bend nose plier (internal) 25-30mm –internal
5. Screw driver.
6. Pipe vice & simple 6" vice.
7. Open end spanner 11-13 mm.
8. Hand punches.
9. Kerosene oil bath.
10. Air jet gun.
11. Slack Adjuster test bench.

Procedure for Maintenance

The slack adjuster shall be overhauled at the time of POH of rolling stock. While dismantling or assembling it is essential to use special tools. Each component of slack adjuster shall be examined. Worn out part shall be checked according to the limits.

[NOTE: For details, refer RDSO Technical pamphlet no. G-92 (September-98)].

The minimum desired characteristic of each spring should be taken as under [Ref: RDSO Technical pamphlet No. G-92 (September -98)]

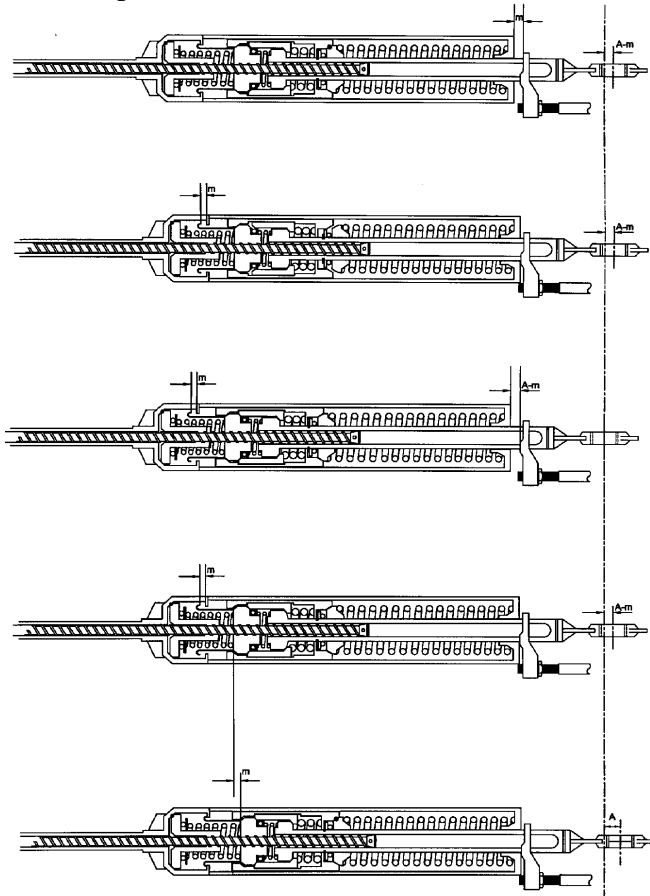

S.N.	Description	Part No.	Spring length compressed	Corrosp. Min permissible force
1.	Barrel spring	21	475 mm	143 Kg.
2.	Pay out spring	11	100 mm	58 Kg.
3.	Take out spring	37	21.5 mm	22 Kg.
4.	Clutch spring	39	38 mm	300 Kg.

Any spring, which does not conform to the above characteristic, should not be used. In addition any of the springs is badly rusted or having compressed coil turns should not be used.

The following parts must be replaced during POH of the slack adjuster [Ref: RDSO Technical pamphlet No. G-92 (September -98)];

- Spring dowel sleeve part No. (18)
- Lock washer part No. (27)
- Seal ring part No. (2)
- Seal ring part No. (43)
- Rubber gasket part No. (4)
- Spring dowel sleeve part No. (25)
- Dog pin part No. (6)
- Tab washer part No. (34)

Lubrication

After cleaning and inspection all parts of slack adjuster should be coated with semi-fluid grease SERVOGEM-RR3 or BALMEROL multi grease LL3 before undertaking re-assembly.

Safety Precautions

The following safety precautions should be observed during overhauling of slack adjuster.

- i. The place of overhauling must be clean and free from dust.
- ii. Ensure that no foreign matter/particle remain inside the sub-assemblies during re-assembly.
- iii. All rubber gasket, seal ring, washers must be replaced during overhaul.
- iv. Specified tools and fixtures to be used for disassembly and assembly operations.

Testing of slack adjuster

After overhauling, the testing of slack adjuster is carried out in a test rack (Fig. 8.12) for: - i) Take up test & ii) Pay out test

- a. Attach the adjuster ear to the free end of the cylinder lever of the test rack
- b. Screw the test rack spindle into the Slack Adjuster until the entire length of thread is covered by spindle sleeve and attach the free end of the spindle to the test rack.

I. Take up or Pay-in test

- Let down the control rod, so that the fork of the rod clasps the adjuster tube of the Slack Adjuster
- Apply and release the brake a few times letting the slack adjuster take up until the correct piston stroke is obtained (until the indicator is within ± 5 mm tolerance field of the scale).

Note: The Slack Adjuster takes up 100 mm per braking.

**Dimension A1 will be 98 +1 mm.
- 4 mm.**

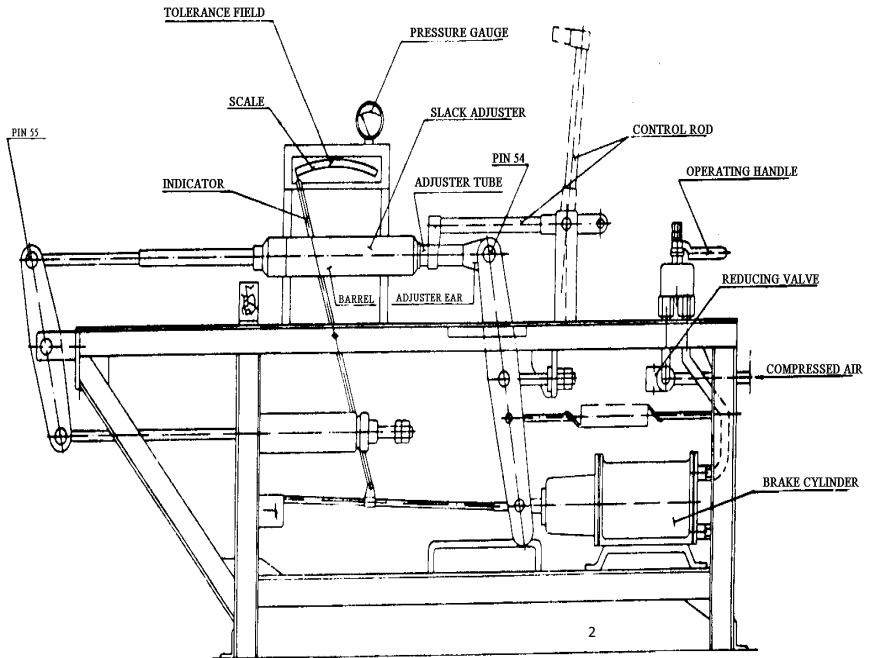

FIG. 20. TEST RACK FOR SLACK ADJUSTER

II. Pay-out test

- Turn up control rod and make two brake applications letting the slack adjuster pay out.

Note : The slack adjuster pays out max. 30 mm per braking

- Repeat the above pay in and pay-out tests a couple of times.
- In case the slack adjuster does not accomplish the above mentioned tests satisfactorily, dismantle it and check that the parts are placed correctly.
- The slack adjuster must then be tested once more in the test rack in accordance with the above

instruction.

- After the test is finished, remove the spindle from the slack adjuster.
- Remove the slack adjuster from the test rack and unscrew adjuster ear 28.

Give adjuster spindle 23 a final thorough inspection making sure that the threads are liberally greased, and screw it into the Slack Adjuster until its end protrudes from Adjuster tube 41. Put the safety collar 24 and secure it with the spring dowel sleeve. Make sure that the spring dowel sleeve pin fits tightly and that its ends do not protrude above the surface of the collar. Should there be any burrs on the collar, smooth off with a fine file and wipe clean. Then screw the adjuster spindle 23 back into the Slack Adjuster enough to make room for the adjuster ear 28.

Slide control rod head 26 with control rod 44 on to adjuster tube 41. Place lock washer 27 on threaded portion of adjuster ear 28 and screw ear into threaded end of adjuster tube 41.

Note: Hold adjuster tube firmly with a pipe wrench. Secure lock washer 27. Install the Slack Adjuster in the brake rigging.

III. Testing of slack adjuster in brake rigging with hand brake

In case a test rack is not available in the work shop, a test of function of the slack adjuster ought to be carried out after the slack adjuster is installed in the brake rigging and the correct piston stroke is obtained as follows:-

- Place an iron object e.g. a hammer between the

brake block and the wheel tread. Make two brake applications after the second application the correct piston stroke should be obtained.

- Remove the iron object. Make two brake applications. After the first application the piston stroke is too long, but after the second application the correct piston stroke is recorded by the slack adjuster.

Painting

The slack adjuster is given a coat of anticorrosive paint, excluding the adjuster tube.

Note : The unthreaded portion of the adjuster spindle 23 should not have a thick coating.

2.13 PROCEDURE FOR BRAKE RIGGING SETTING AND MEASUREMENT OF “A” AND “e” DIMENSIONS.

The procedure to be adopted for operating brake rigging setting and measuring ‘A’ and ‘e’ dimension is listed below:-

For ‘A’ dimension

- (i) Ensure the air brake is in fully released condition and all the brake rigging gears are in proper condition.
- (ii) Apply brake three to four times to ease the rigging, by dropping and re-charging the air pressure in the brake pipe
- (iii) Ensure once again that brake rigging is in fully released condition.

If ‘A’ dimension is not correct

- (iv) Remove pin securing the control rod in U bracket.
- (v) Detach control rod and rotate it to adjust the gap

between barrel end face & control rod head as specified in note above. Secure the control rod in U bracket.

- (vi) Apply brakes two to three times.
- (vii) Check the 'A' dimension using the gauge.
- (viii) Recheck dimension 'A' with brakes fully released after every brake release.
- (ix) Lock the control rod head firmly with check nut and tooth lock washer.
- (x) Secure pin with split pin.

For 'e' dimension

- (i) If slack is in excess beyond the capacity of slack adjuster ('e' dimension 555 - 575mm other than higher axle load wagon) there won't be any slack take up provision in the slack adjuster and slack adjuster will only act as strut/pull rod. This is because of brake shoes and wheel wear reaching their condemning limit/near condemning limit. In such cases the 'e' dimension can be restored by adjusting link provided on the bogie frame head stock.
- (ii) Measure 'e' dimension i.e. distance between protection tube end and mark on adjuster spindle using measuring stick after two or three brake application. It should be set to nearly to its maximum limit i.e. 555 - 575mm other than higher axle load wagon.

OUR OBJECTIVE

To upgrade maintenance technologies and methodologies and achieve improvement in productivity and performance of all Railway assets and man power which inter-alia would cover reliability, availability, utilisation and efficiency.

If you have any suggestions and any specific comments, please write to us.

Contact person : *Director/Mech*

Postal address : *Indian Railways,
Centre for Advanced
Maintenance Technology,
Maharajpur, Gwalior.
Pin code - 474 005*

Phone : 0751- 2470890

Fax : 0751- 2470841

Email address : dirmech@gmail.com