



TABLE OF CONTENTS

- A - PRIMARY COMPONENTS
- B - OVERALL VIEW OF COMPONENTS
- C - END AND MID CLAMPS ASSEMBLIES
- D - BEAM CLIP AND BEAM SPLICE
- E - TOP CHORD AND DIAGONAL BRACE PILE CONNECTIONS
- 1-22 - STEP BY STEP INSTALLATION INSTRUCTIONS
- 23 - ELECTRICAL CONSIDERATIONS
- 24 - BONDING GROUND PATHS
- 25 - MODULE COMPATABILITY
- 27 - APPENDIX TABLE OF CONTENTS

NOTE:
GFT construction
drawings have
precedence over these
installation guidelines.

PUB2019APR24V2

Safety Note: Cold formed steel components may have sharp edges after fabrication. Appropriate PPE should be worn to avoid injury.

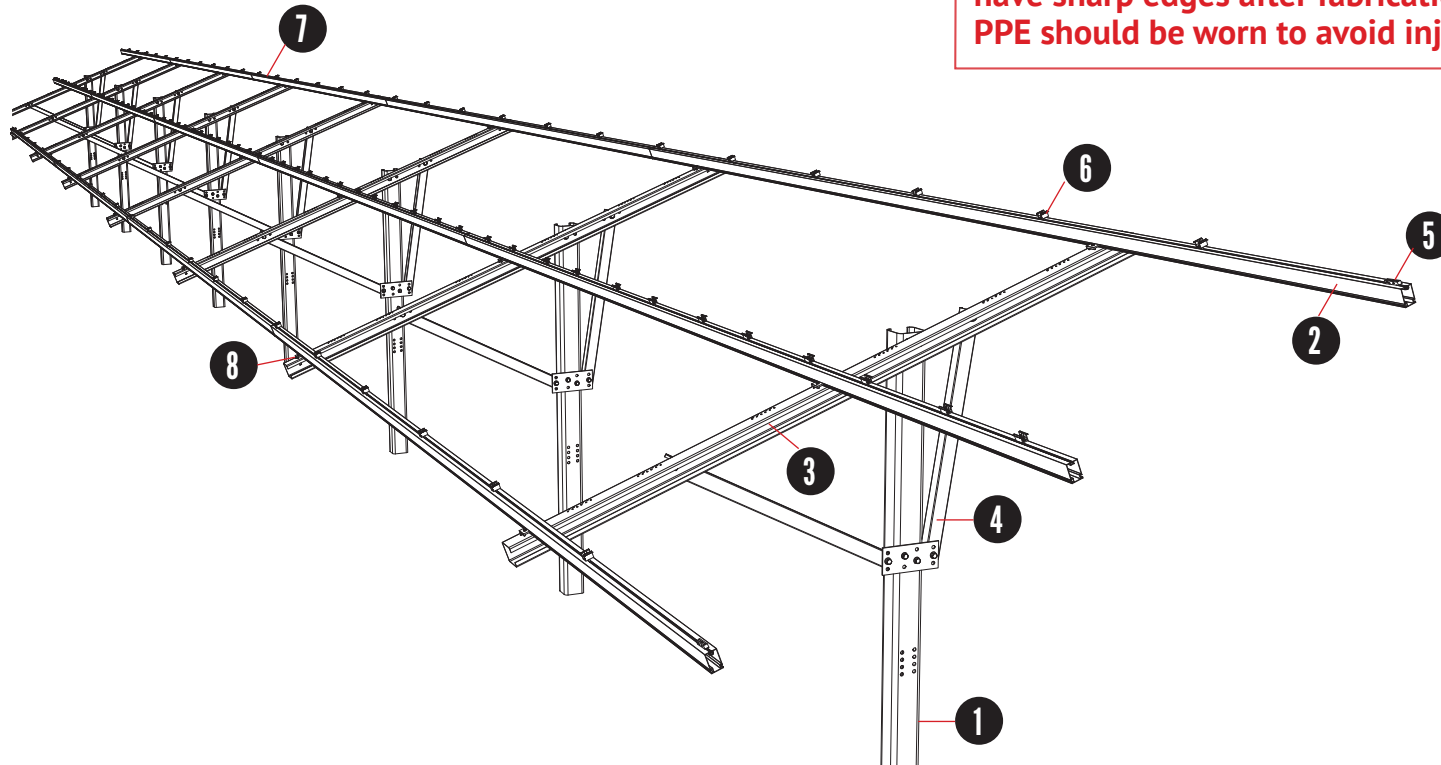

ITEM	COMPONENT	MATERIAL
1	Roll- Formed Steel Pile	4.5 " x 6" C Shape (Length Varies)
2	Aluminum East-West Beam	Aluminum Beam with Continuous Slots for Adjustability
3	Roll-Formed Steel Top Chord	C Shape with Hole Pattern for Adjustability
4	Diagonal Brace Assembly	Roll-formed Front and Rear Diagonal Brace with Steel Plate
5	End Clamp	End Clamp Assembly
6	Mid Clamp	Mid Clamp Assembly
7	E-W Beam Splice	Internal Aluminum Splice Retained with Self-Tapping Screws
8	East-West Beam Clip	Aluminum Extruded Clamp with Stainless Steel Hardware

TORQUE REQUIREMENTS FOR THE GFT PRODUCT:

	HARDWARE TYPE	TORQUE	SOCKET SIZE
Racking Hardware	1/4" Ø Hardware =	9 - 11 Ft-LBS	7/16"
	5/8" Ø Hardware =	54 - 66 Ft-LBS	15/16"
	3/4" Ø Hardware =	99 - 121 Ft-LBS	1 1/8"
Module Hardware	Pro-Series Mid-Clamp	10 - 12 Ft-LBS	1/2"
	Pro-Series End Clamp	3 Ft-LBS	1/2"

Note: Insure torque wrenches have been calibrated.

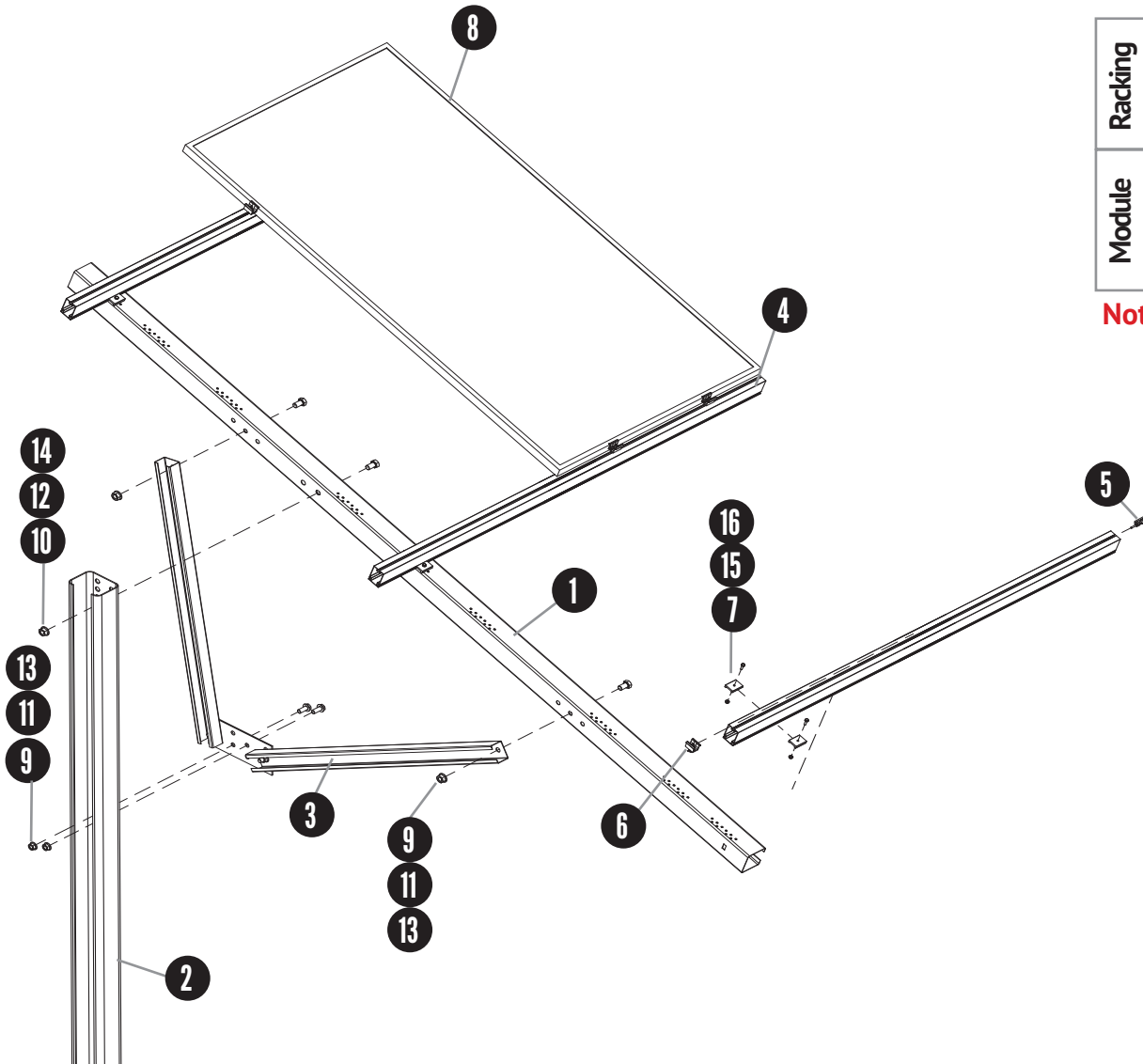

ITEM	COMPONENT
1	4.1" Top Chord Channel
2	6" x 4.5" 11 Gauge Pile
3	Diagonal Brace Assembly
4	3.25" x 2" East-West Aluminum Beam
5	End Clamp Assembly
6	Mid Clamp Assembly
7	Hex Flange Nut 1/4-20 Serrated
8	PV Module (By Others)
9	Flat Washer 5/8"
10	Flat Washer 3/4"
11	Hex Bolt 5/8-11" x 1"
12	Hex Bolt 3/4-10" x 1-1/2"
13	Hex Flange Nut 5/8-11 Serrated
14	Hex Flange Nut 3/4-10 Serrated
15	Hex Bolt 1/4-20 x 1"
16	East-West Beam Clip

Mid Clamp Assembly with T-Bolt

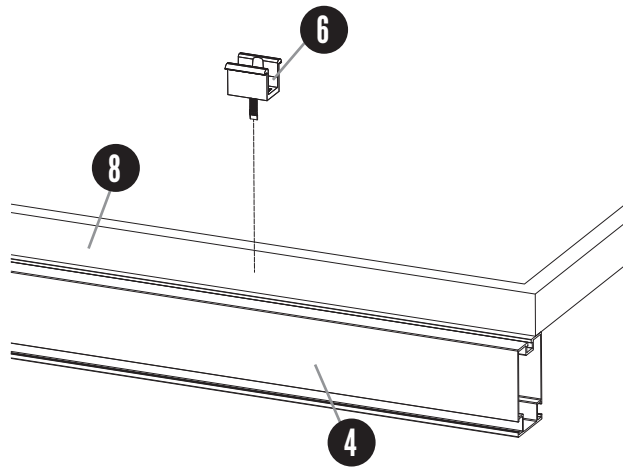

End Clamp Assembly

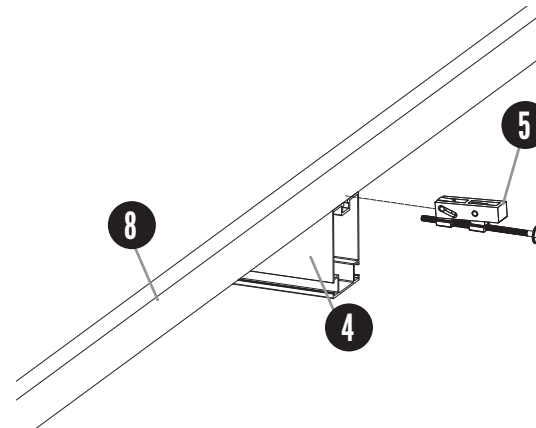

Mid Clamp Assembly With T-Bolt

ITEM	COMPONENT	MATERIAL
4	3.25" x 2" East-West Aluminum Beam	Aluminum Alloy 6005A-T61, 6351-T5 or 6061-T6, Fy = 35 ksi, Ft _u = 38 ksi
6	Mid Clamp	Aluminum Alloy 6005A-T61, 6351-T5 or 6061-T6, Fy = 35 ksi, Ft _u = 38 ksi
8	PV Module (By Others)	As per Manufacturer
SEE DWG	1/4-20 T-Bolt (Serrated or Non-Serrated)	300 Stainless Steel (301 Preferred) with Min Ft _u = 70 ksi
SEE DWG	1/4-20 Serrated Flange Nut	Stainless Steel ASTM F594 with Min Ft _u = 70 ksi

End Clamp Assembly

ITEM	COMPONENT	MATERIAL
4	3.25" x 2" East-West Aluminum Beam	Aluminum Alloy 6005A-T61, 6351-T5 or 6061-T6, Fy = 35 ksi, Ft _u = 38 ksi
5	End Clamp	Aluminum Alloy 6005A-T61, 6351-T5 or 6061-T6, Fy = 35 ksi, Ft _u = 38 ksi
8	PV Module (By Others)	As per Manufacturer
SEE DWG	#10-32 Bolt with 1/2" Hex Head	300 Stainless Steel (301 Preferred) with Min Ft _u = 70 ksi
SEE DWG	1/4-20 Serrated Flange Nut	Stainless Steel ASTM F594 with Min Ft _u = 70 ksi

East-West Beam Clip

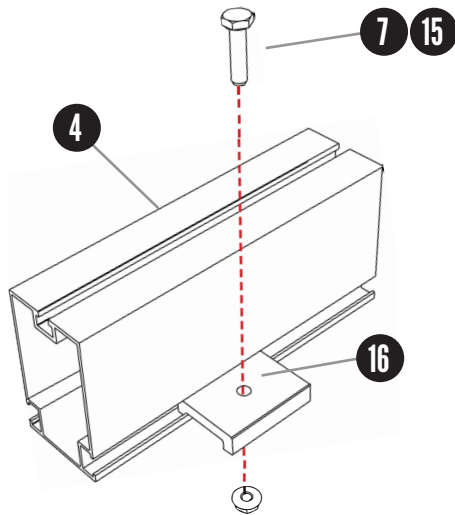

East-West Beam Splice

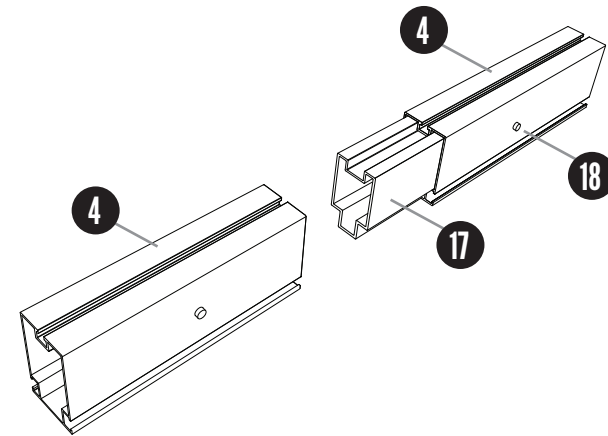

East-West Rail Clip

ITEM	COMPONENT	MATERIAL
4	3.25" x 2" East-West Aluminum Beam	Aluminum Alloy 6005A-T61, 6351-T5 or 6061-T6, Fy = 35 ksi, Ft _u = 38 ksi
7	Hex Flange Nut 1/4-20 Serrated	302HQ 18/8 Stainless Steel Austenitic 300 Series, Min Ft _u = 85 ksi
15	Hex Bolt 1/4-20 x 1"	302HQ 18/8 Stainless Steel Austenitic 300 Series, Min Ft _u = 85 ksi
16	East-West Beam Clip	Aluminum Alloy 6005A-T61, 6351-T5 or 6061-T6, Fy = 35 ksi, Ft _u = 38 ksi

East-West Beam Splice

ITEM	COMPONENT	MATERIAL
4	3.25" x 2" East-West Aluminum Beam	Aluminum Alloy 6005A-T61, 6351-T5 or 6061-T6, Fy = 35 ksi, Ft _u = 38 ksi
17	East-West Beam Splice Insert	Aluminum Alloy 6005A-T61, 6351-T5 or 6061-T6, Fy = 35 ksi, Ft _u = 38 ksi
18	1/4" x 20 Self Drilling Screw (Buildex)	Grade 5, ASTM A449/ SAE J429 (Similar Properties Confirmed by testing)

Top Chord to Pile Connection

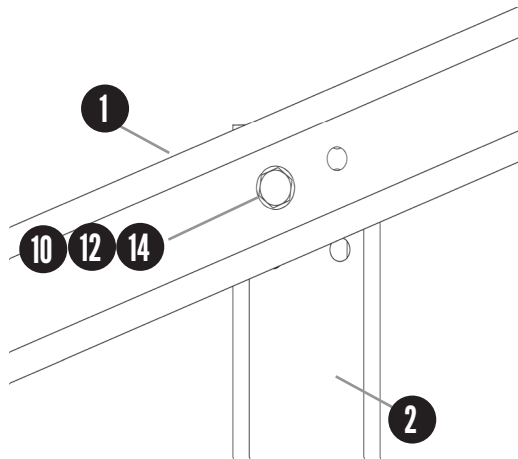

Diagonal Brace Plate to Pile Connection

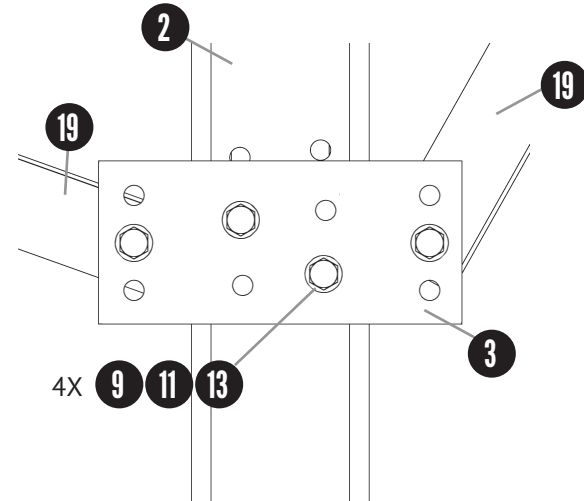

Top Chord to Pile Connection

ITEM	COMPONENT	MATERIAL
1	4.1" Top Chord Channel	Cold Rolled ASTM A653 HSLAS Grade 50 or 55
2	6" x 4.5" C-Shape Pile	Cold Rolled ASTM A653 HSLAS Grade 50 or 55
10	Flat Washer 3/4"	SAE Type A Narrow
12	Hex Bolt 3/4-10 x 1-1/2"	SAE J429-Grade Varies per Project
14	Hex Flange Nut 3/4-10 Serrated	SAE J429-Grade Varies per Project

Diagonal Brace Plate to Pile Connection

ITEM	COMPONENT	MATERIAL
2	6" x 4.5" C Shape Pile	Cold Rolled ASTM A653 HSLAS Grade 50 or 55
3	Diagonal Brace Plate	ASTM A36 or ASTM A653 GR 50 Steel
9	Flat Washer 5/8"	SAE Type A Narrow
11	Hex Bolt 5/8-11 x1"	SAE J429-Grade Varies per Project
13	Hex Flange Nut 5/8-11 Serrated	SAE J429-Grade Varies per Project
19	Diagonal Brace	Cold Rolled ASTM A653 HSLAS Grade 50 or 55

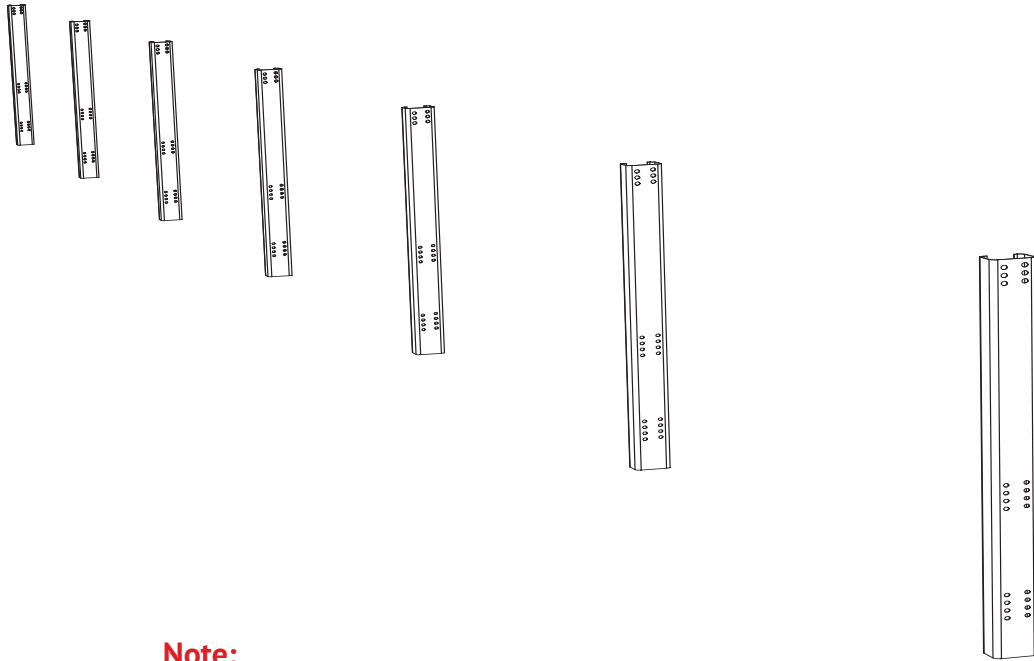

Note:
C-Piles must be installed with C open to the West.

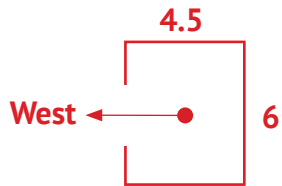

All piles within single table must be oriented to face the same direction per the construction drawings.

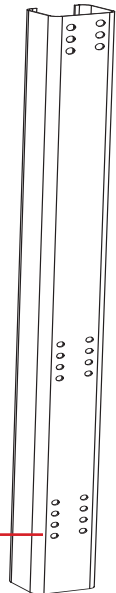

Hole height above grade per construction drawings.

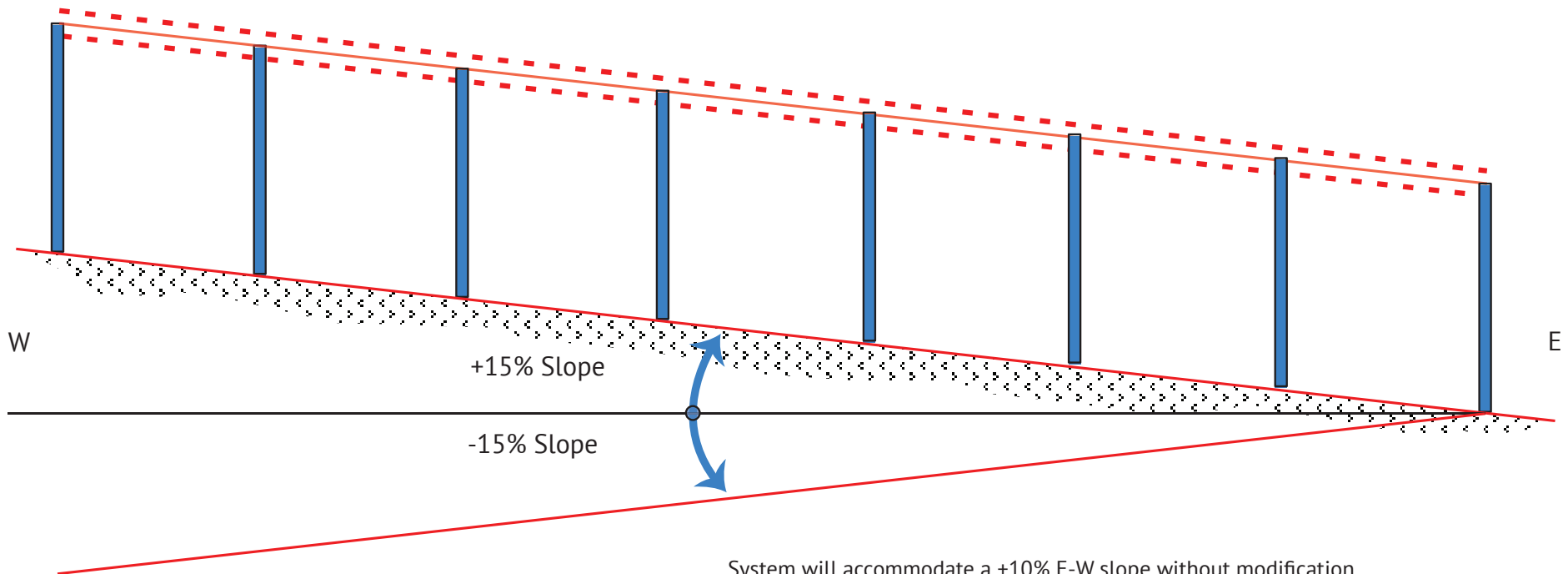

- System will accommodate a $\pm 10\%$ E-W slope without modification.
- Plumb tolerances apply regardless of slope.
 - Pile position tolerances apply relative to nominal finish grade line.

Note:

The GFT system has been installed at an E-W slope of 15%. This is achievable, but requires additional effort to ensure that holes align for bolted connection.

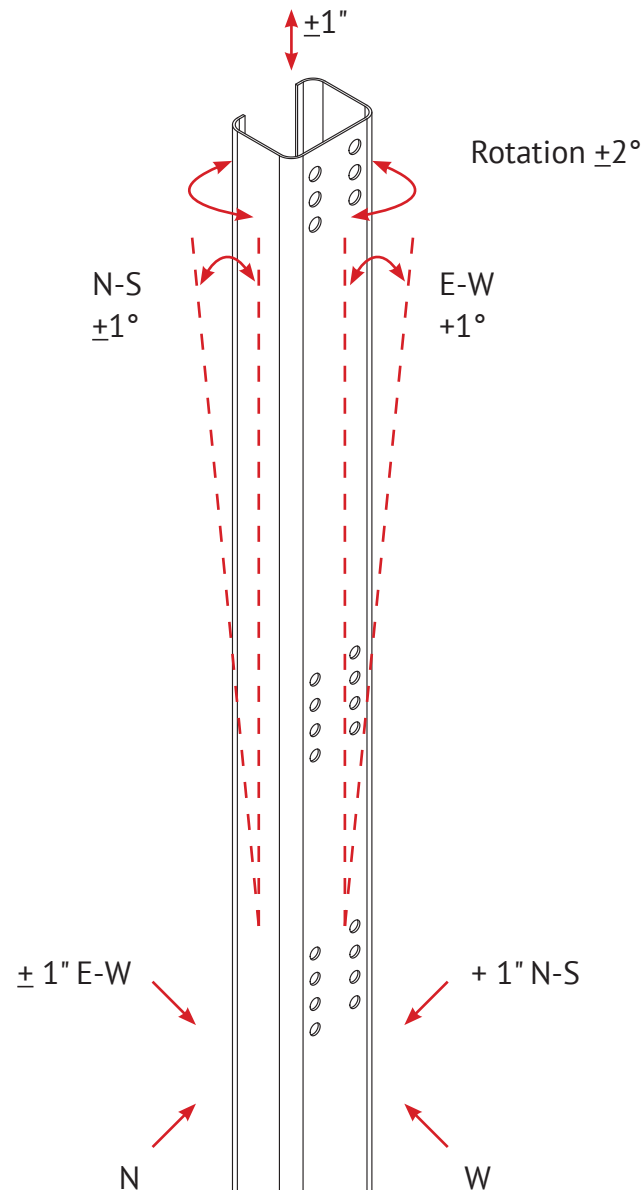

1. Align target hole locations in all piles (within tables and table to table) using laser or string line.
2. Determine if adjustments are needed up or down (hole patterns allow for + 1-1/2" adjustments in 3/4" increments per instruction on following pages).
3. Mark holes to be used for top chord and diagonal brace plate attachments prior to installing.

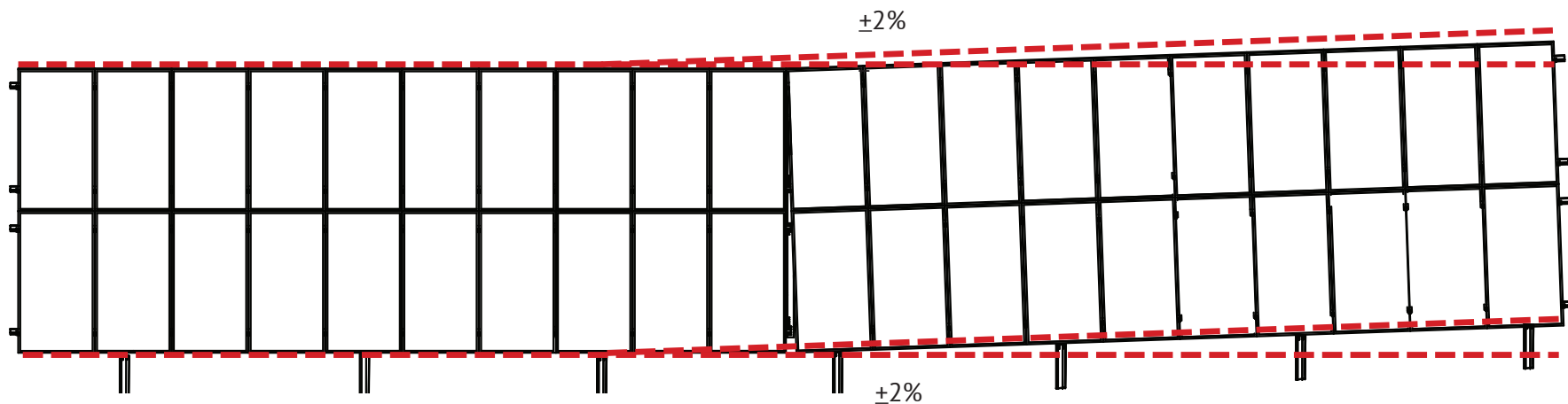
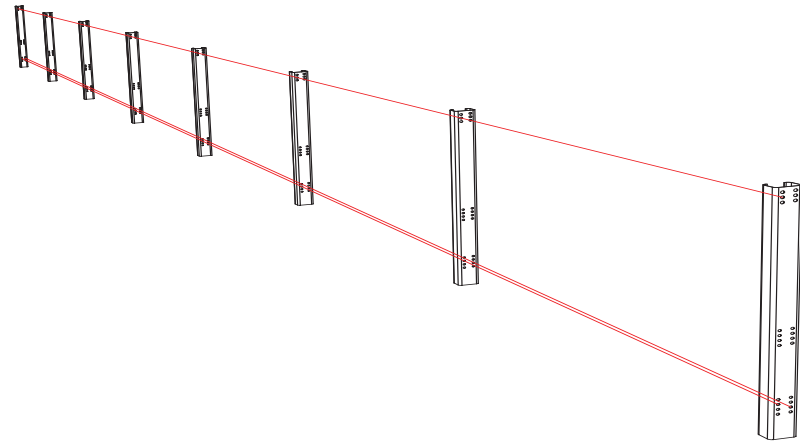

The system is capable of being aligned to the target string or laser line using the adjustment holes when piles are placed within allowable tolerances. Each table will however accommodate a 2% deviation from the target line as shown without impact to structural integrity.

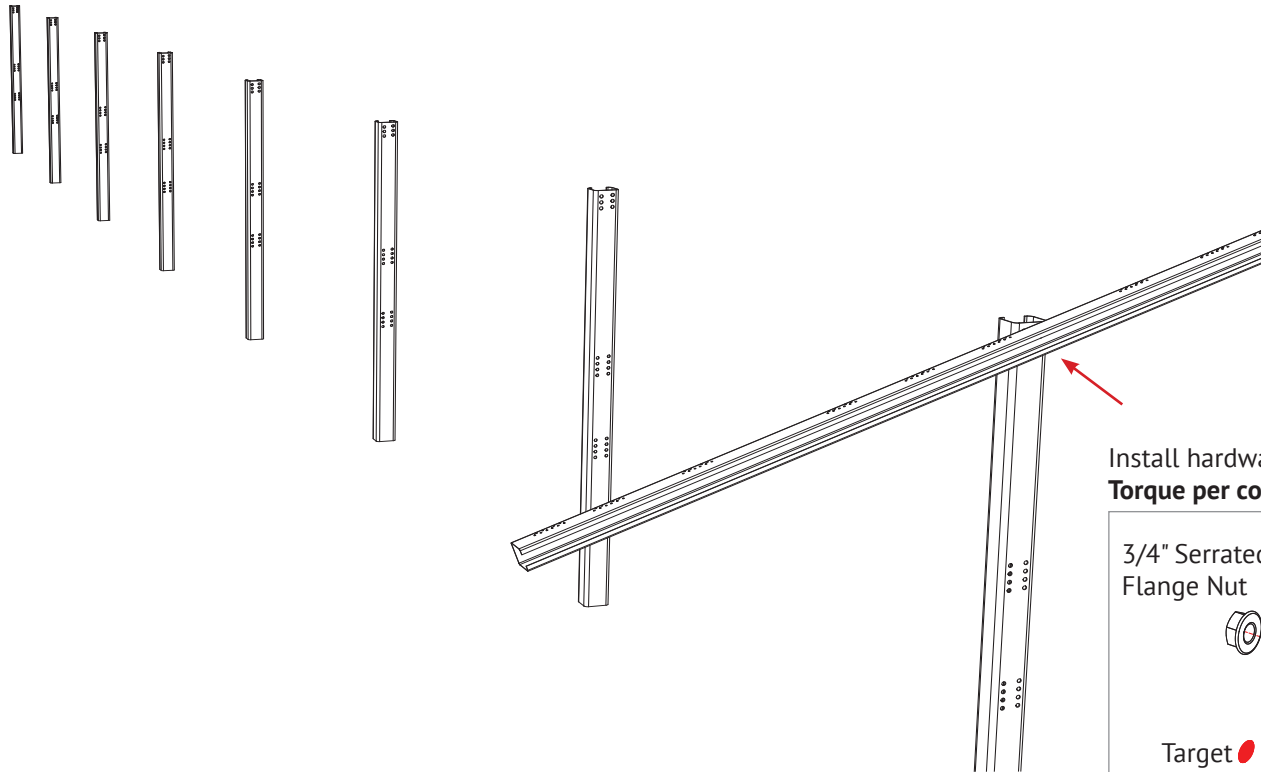

Install hardware snug tight.
Torque per construction drawings after final adjustments.

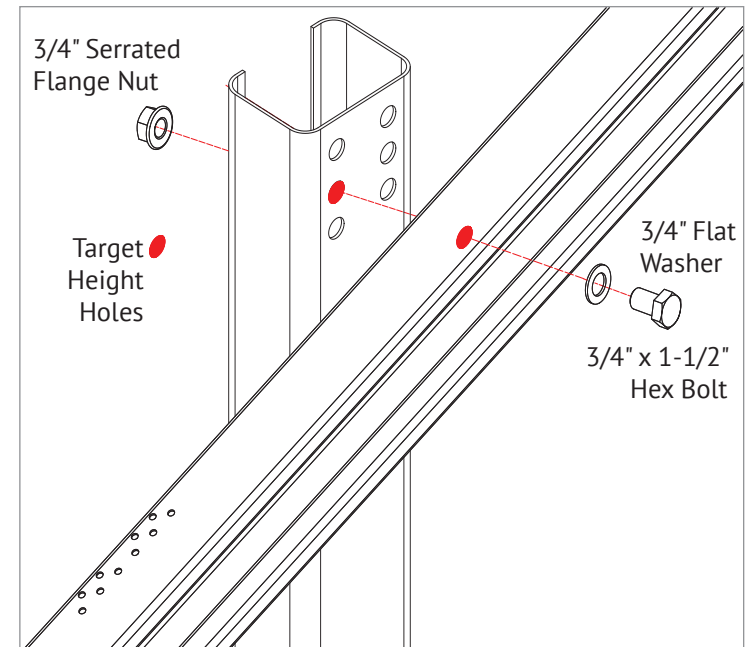

Target Height

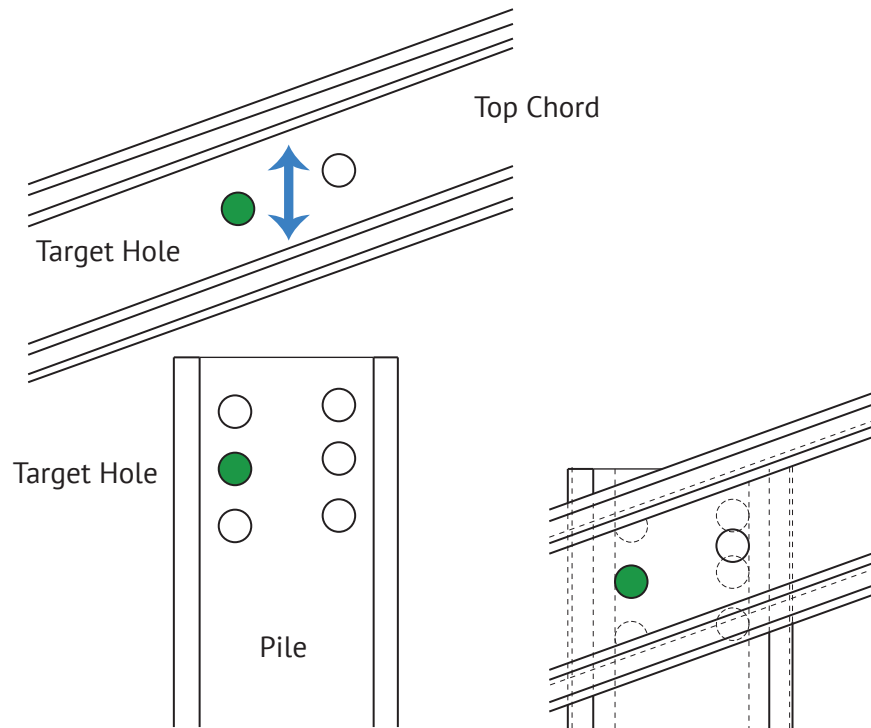

Move top chord up or down (not horizontally) as needed to adjust height in 3/4" increments.

Use single 3/4" bolt (nut and washer) at one of the locations shown.

Adjustment Locations (Single 3/4" Bolt)

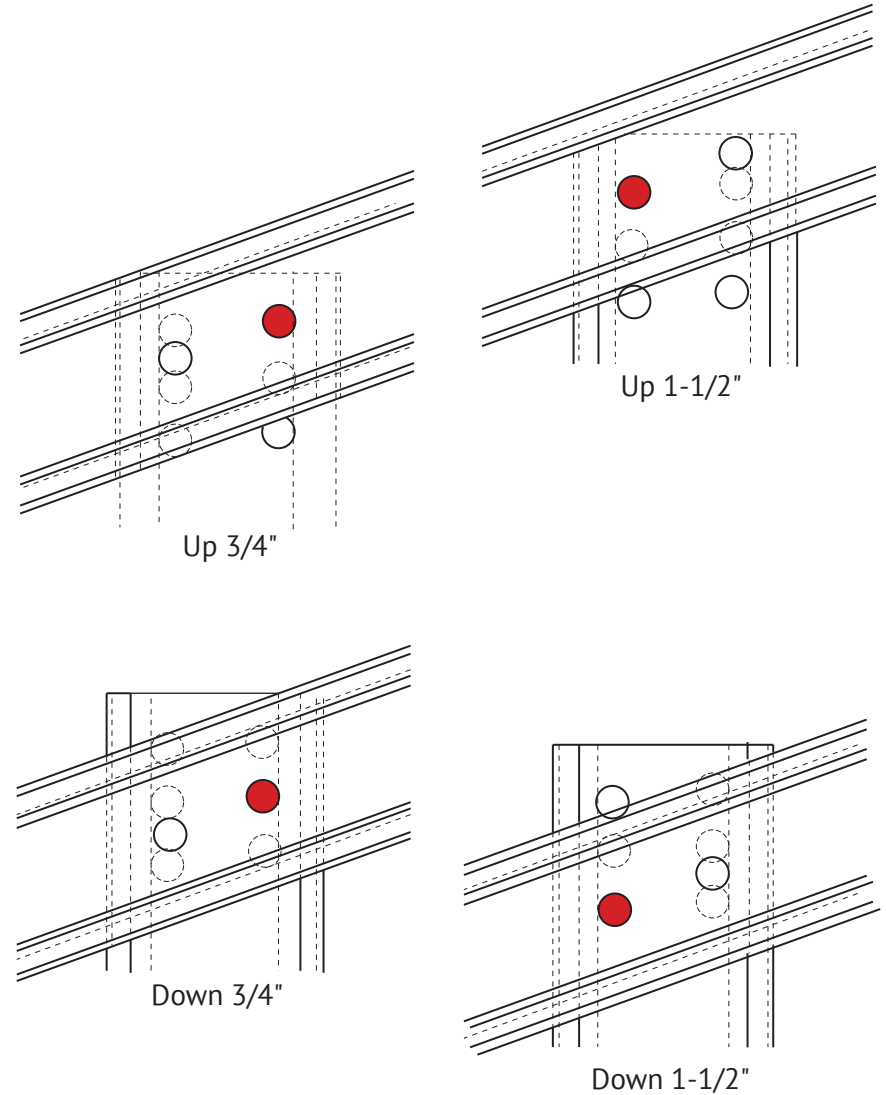

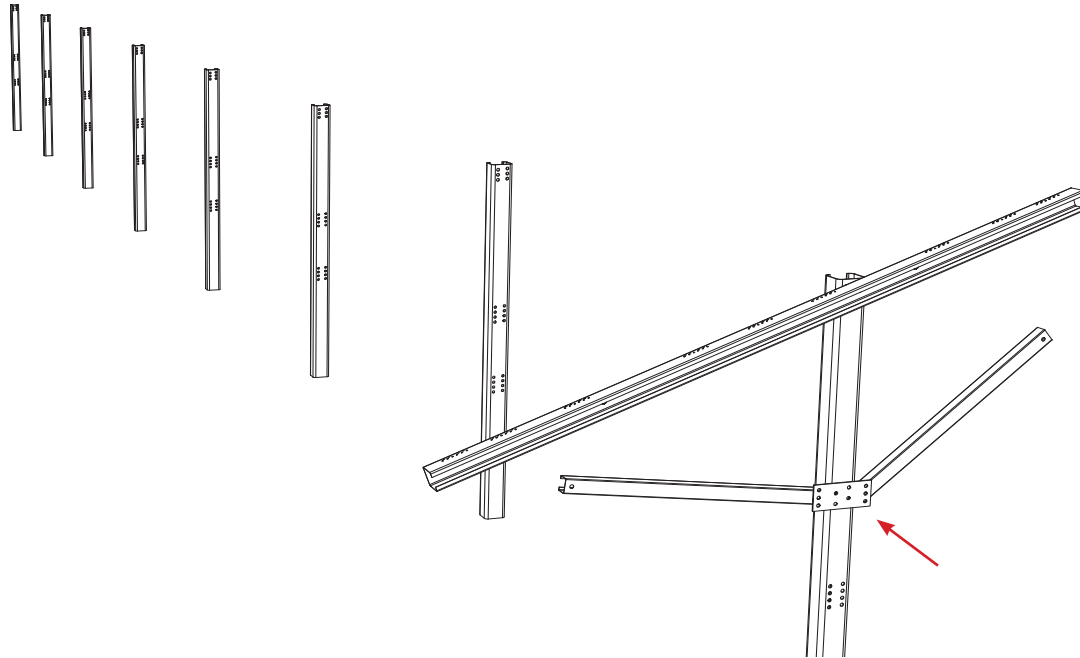

Diagonal Brace Assembly

Install hardware snug tight.
Torque per construction drawings after final adjustments.

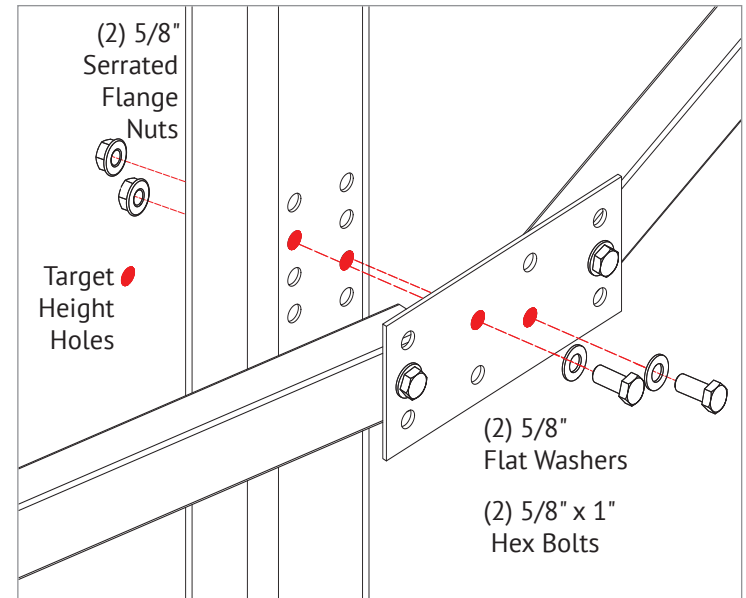

Target Height

Move diagonal brace plate up or down (not horizontally) as needed to adjust height in 3/4" increments.

Use pair of 5/8" bolts (nuts and washers) at location shown.

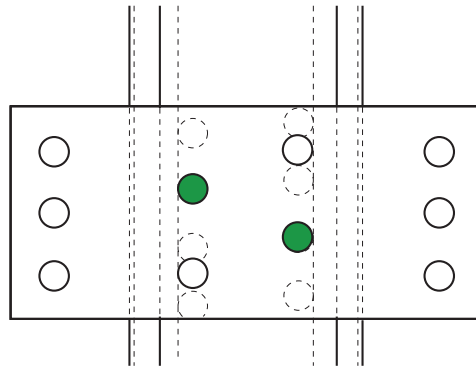

Target Height

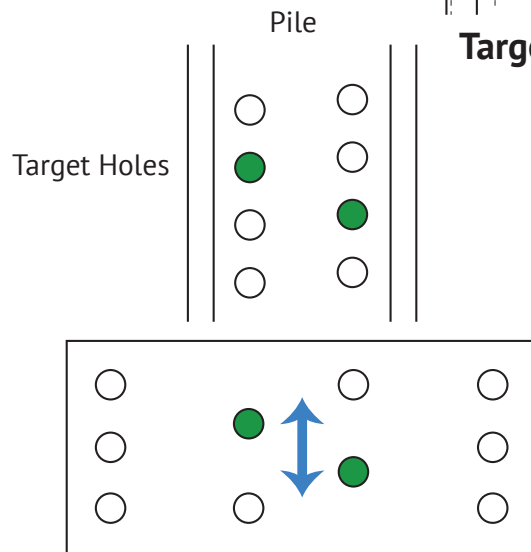

Diagonal Brace Plate

Adjustment Locations (Pair of 5/8" Bolts)

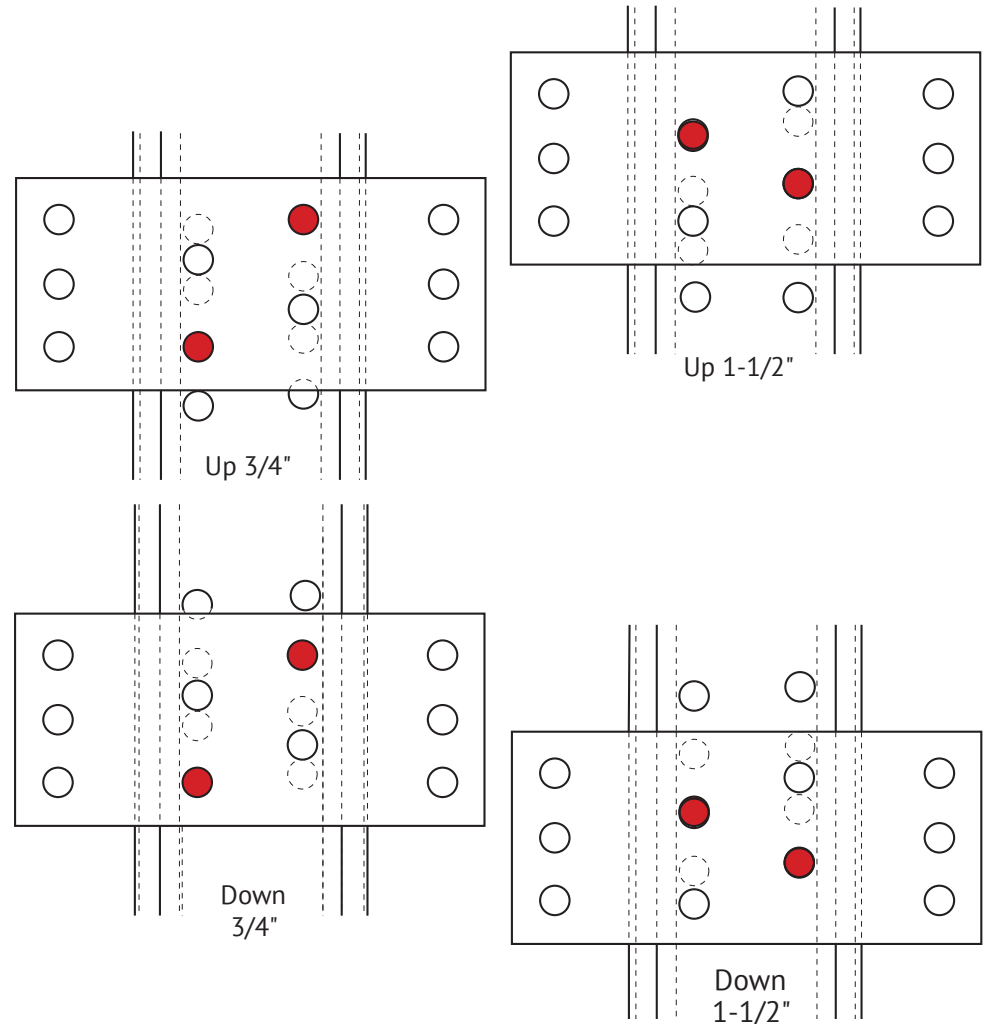

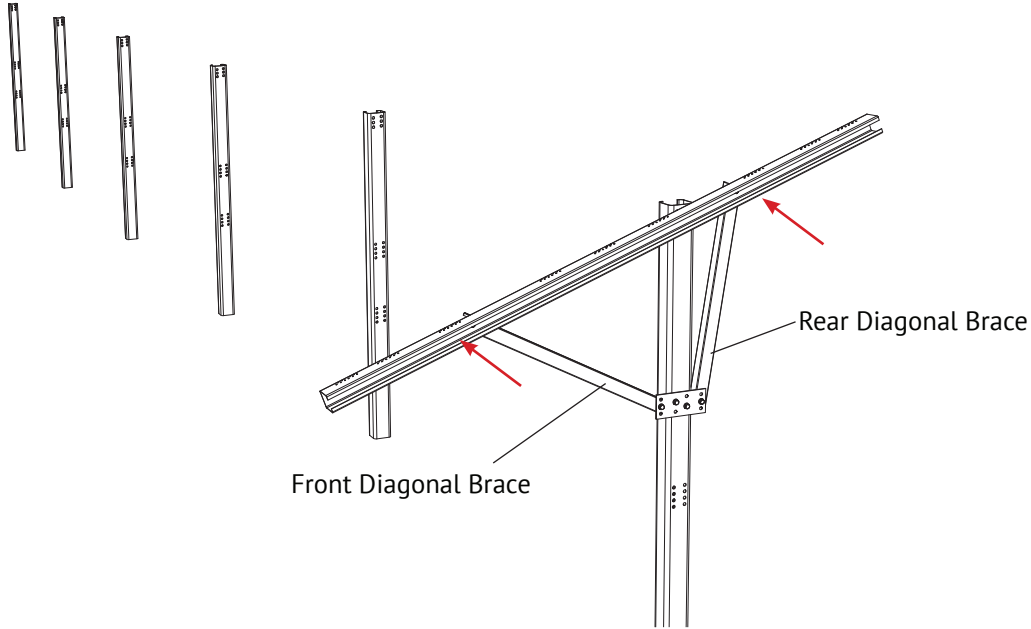

Install hardware snug tight.
Torque per construction drawings after final adjustments.

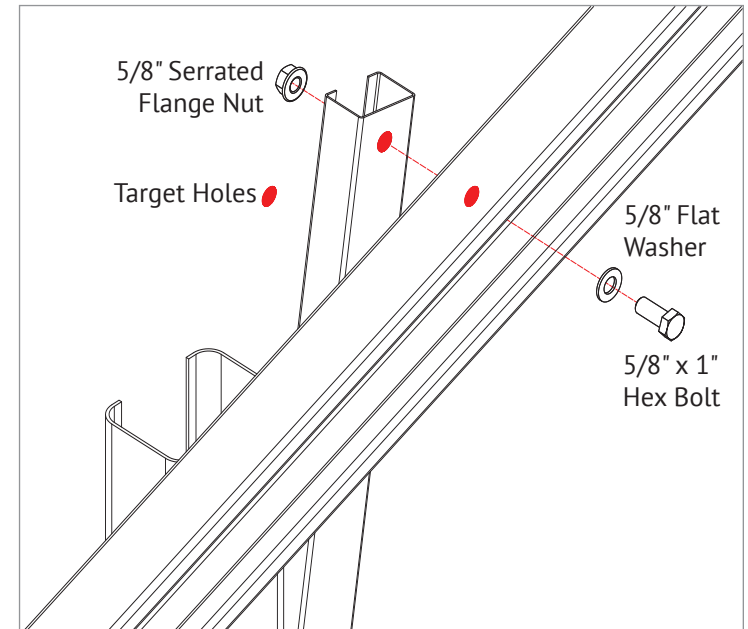

Torque all bolts after final adjustments.
Refer to Torque values stated on page B of the
installation manual and in the general notes
section of the construction drawings.

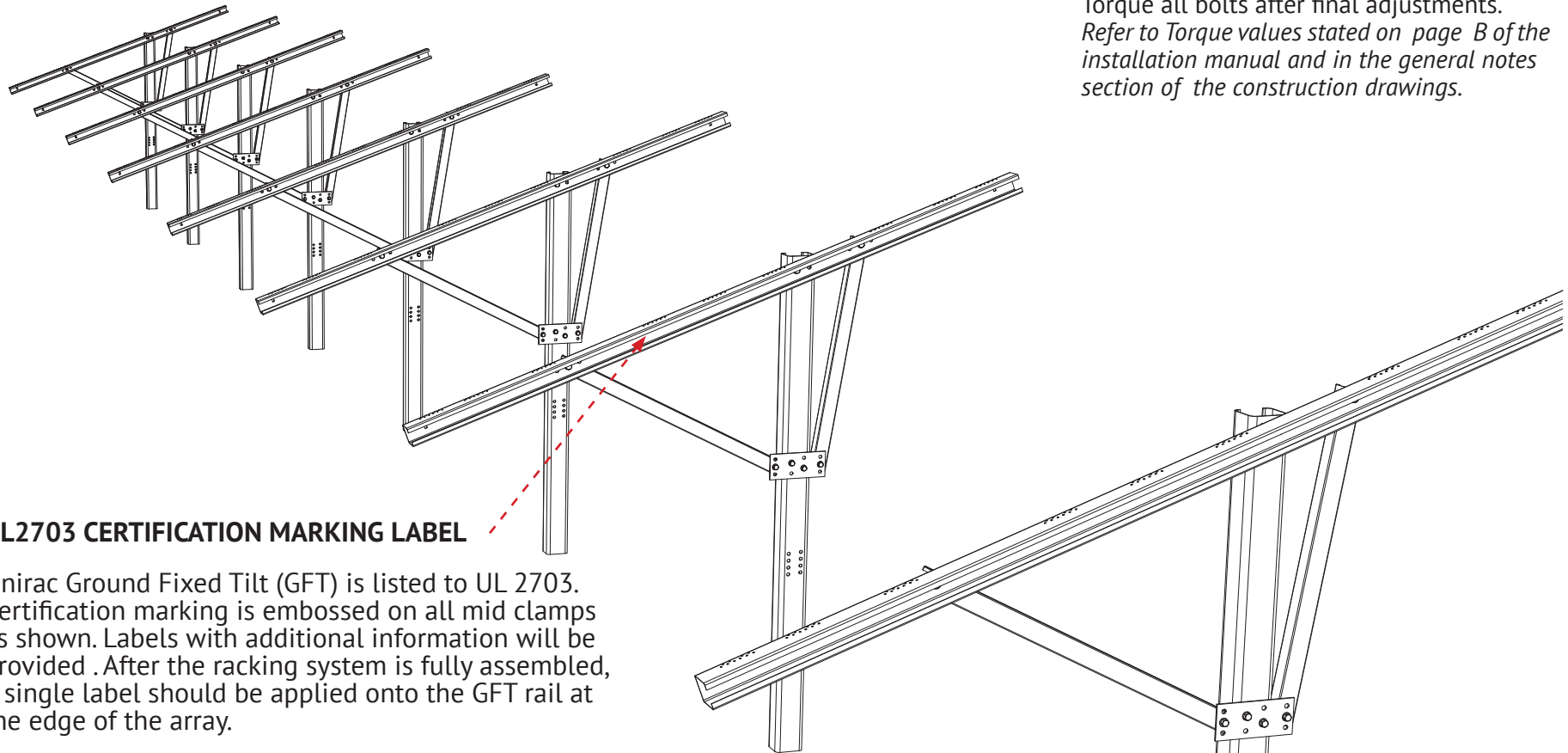

UL2703 CERTIFICATION MARKING LABEL

Unirac Ground Fixed Tilt (GFT) is listed to UL 2703. Certification marking is embossed on all mid clamps as shown. Labels with additional information will be provided. After the racking system is fully assembled, a single label should be applied onto the GFT rail at the edge of the array.

Note:
The sticker label should be placed such that it is visible, but not outward facing.

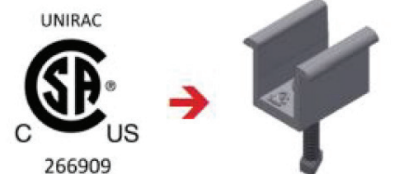

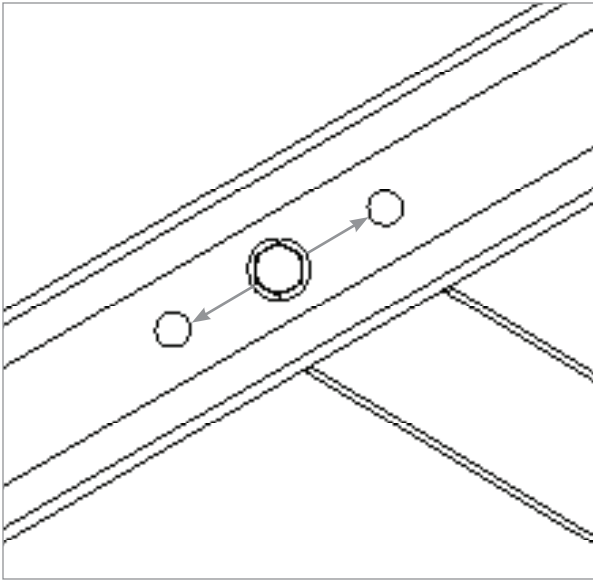

If required, additional minor adjustment of top chord angle may be achieved by a combined repositioning of diagonal braces to adjacent holes in top chord and diagonal brace plate.

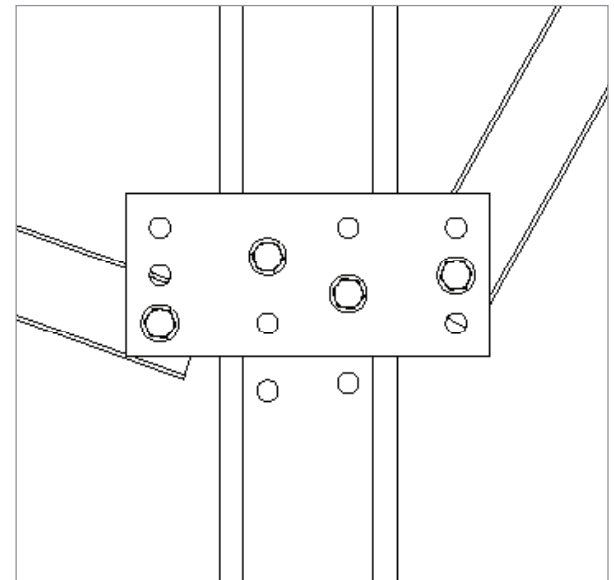
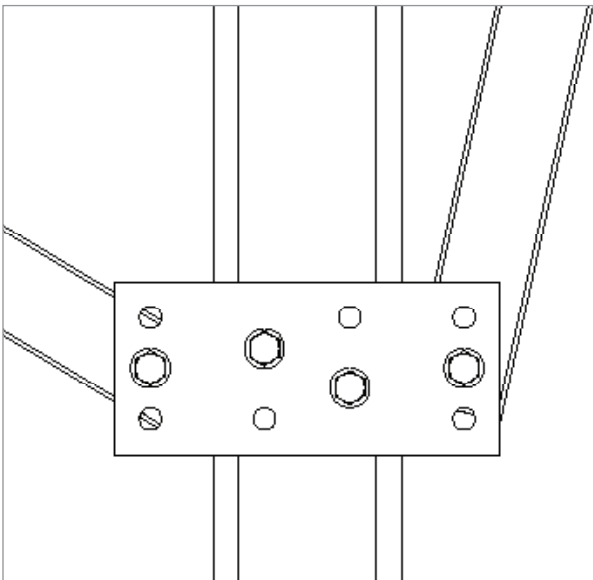
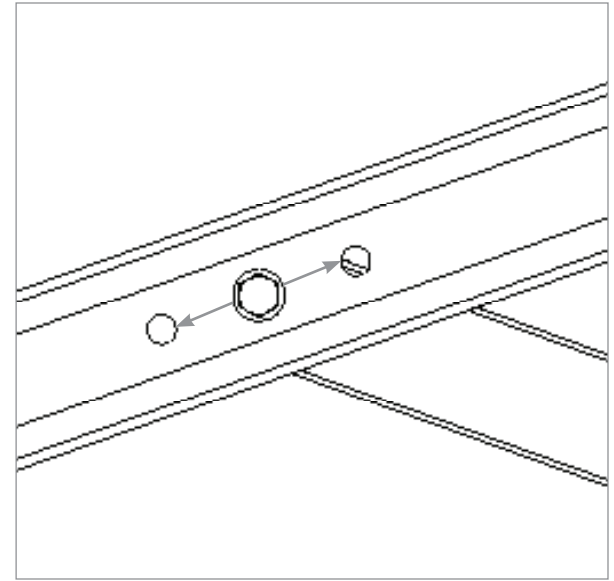

1. Align target hole locations using laser or string line.
2. Determine if adjustments are needed up or down.
(hole patterns allow for +1" adjustment in 1/2" increments per instruction on following pages).
3. Mark holes to be used for attaching E-W beams prior to installing.

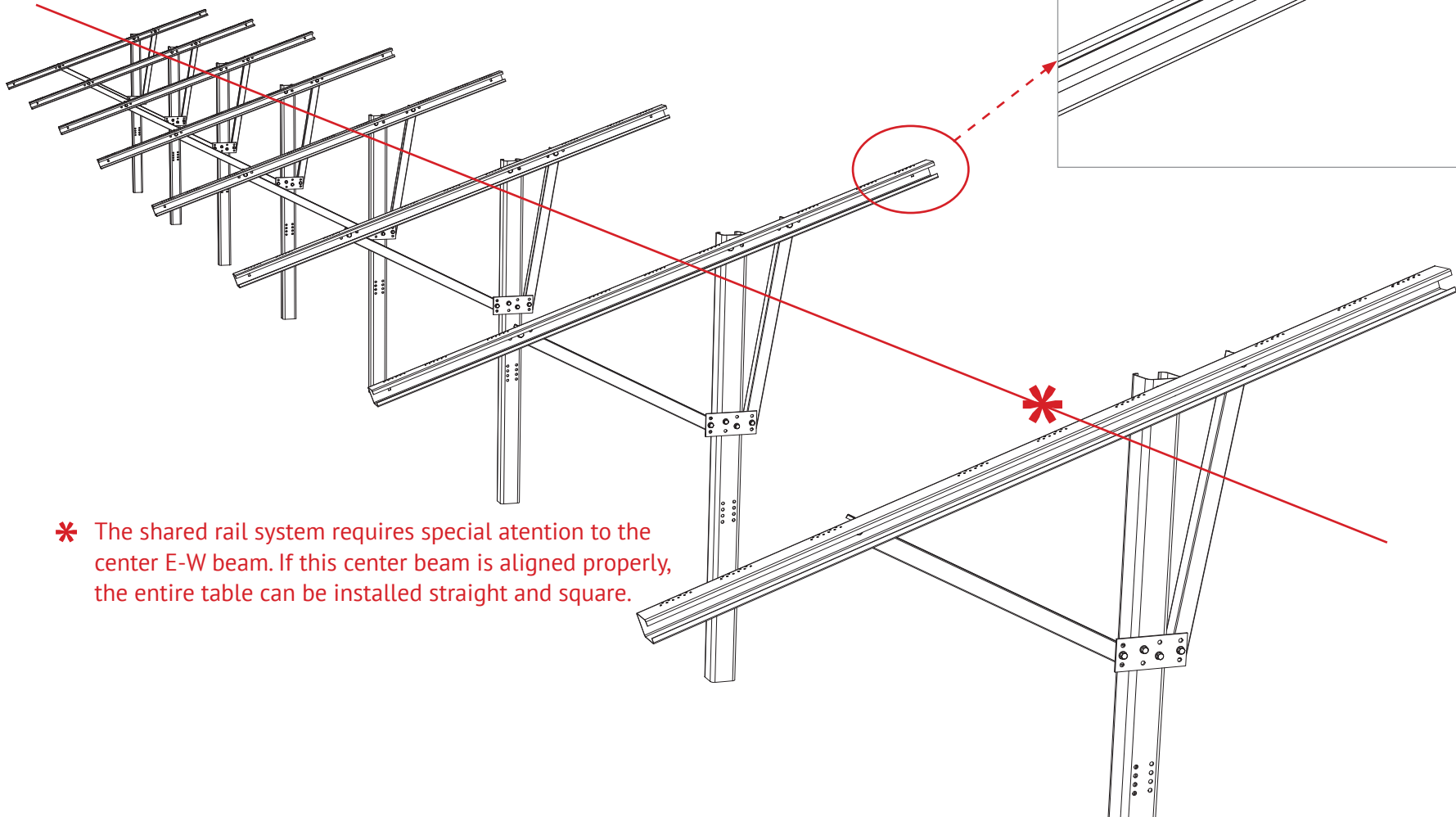
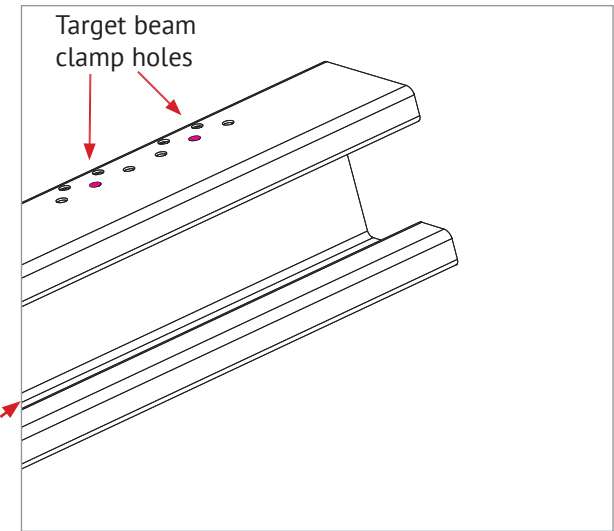

* The shared rail system requires special attention to the center E-W beam. If this center beam is aligned properly, the entire table can be installed straight and square.

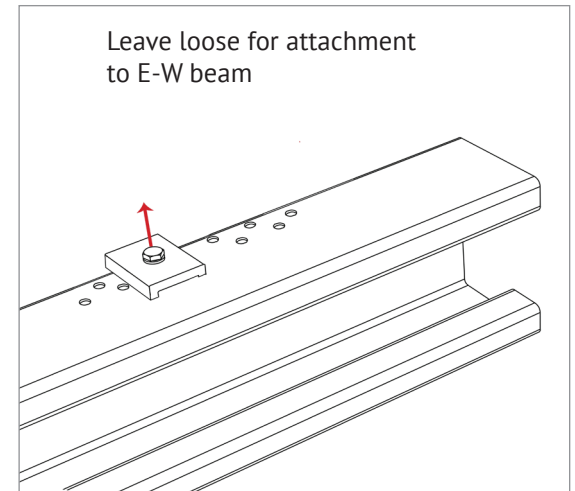
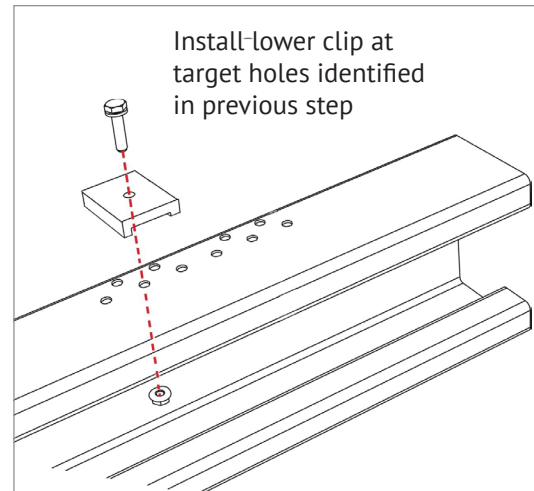

Install clips to top chords on low sides of beams only

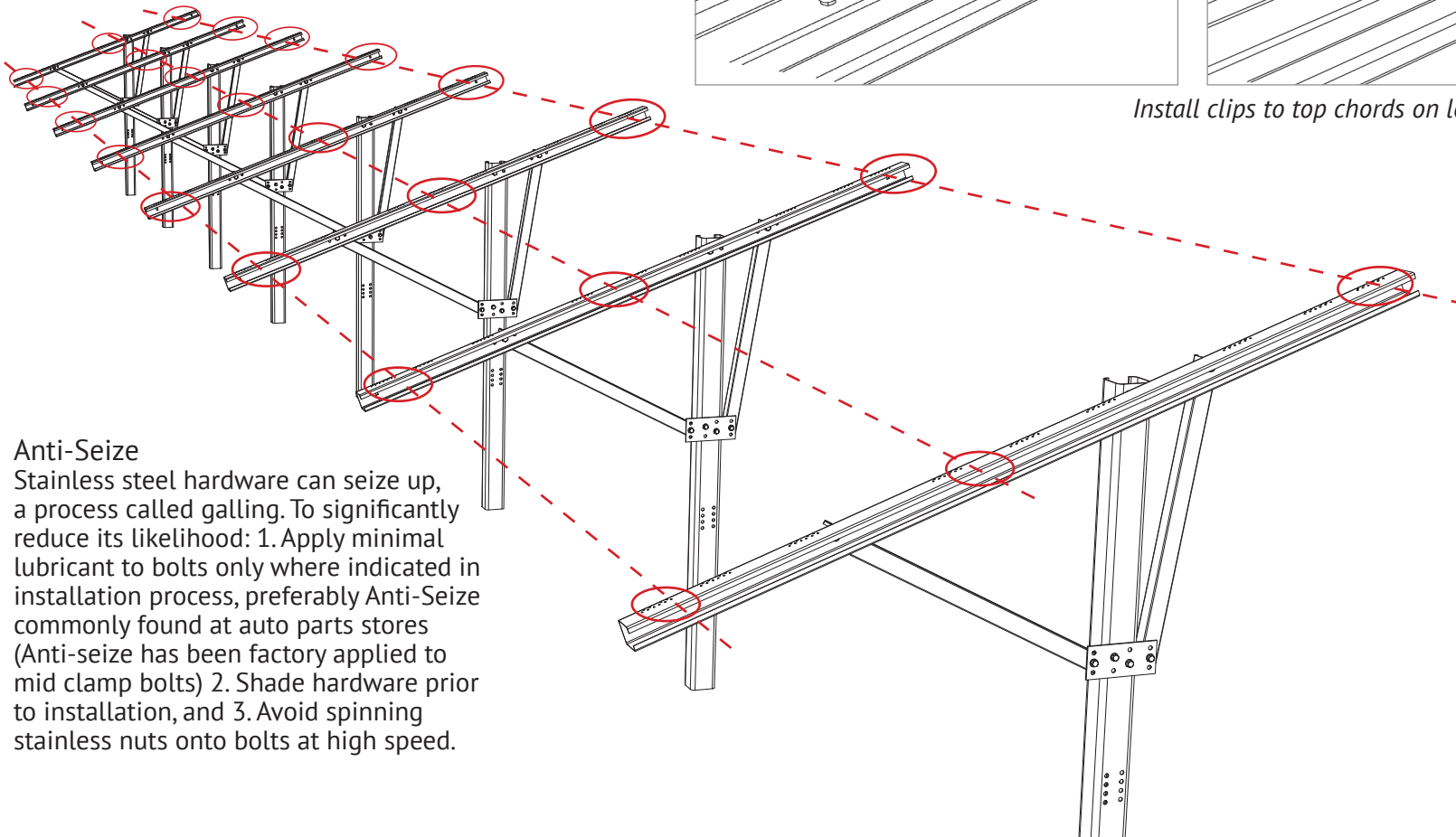

Anti-Seize

Stainless steel hardware can seize up, a process called galling. To significantly reduce its likelihood: 1. Apply minimal lubricant to bolts only where indicated in installation process, preferably Anti-Seize commonly found at auto parts stores (Anti-seize has been factory applied to mid clamp bolts) 2. Shade hardware prior to installation, and 3. Avoid spinning stainless nuts onto bolts at high speed.

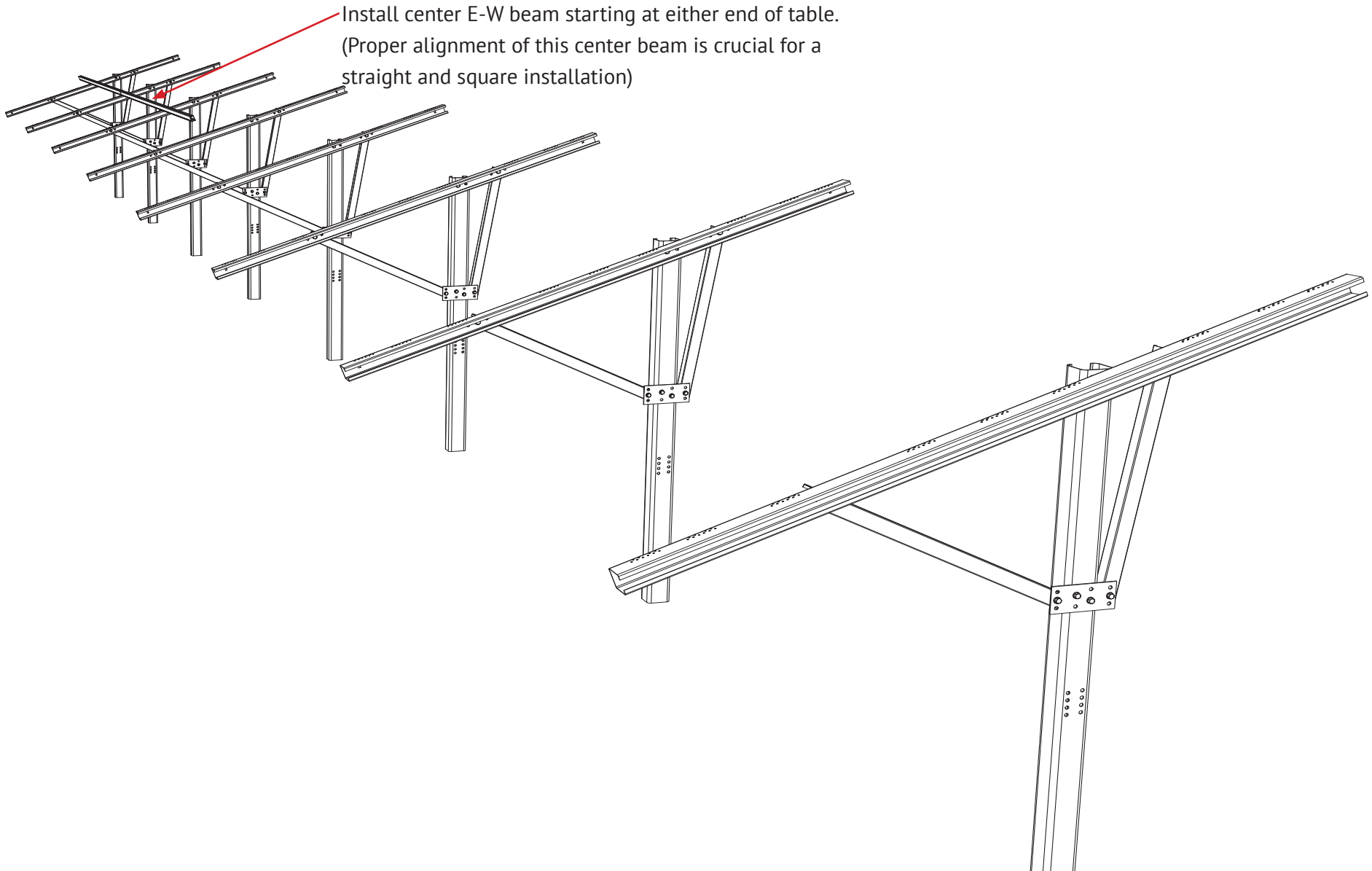

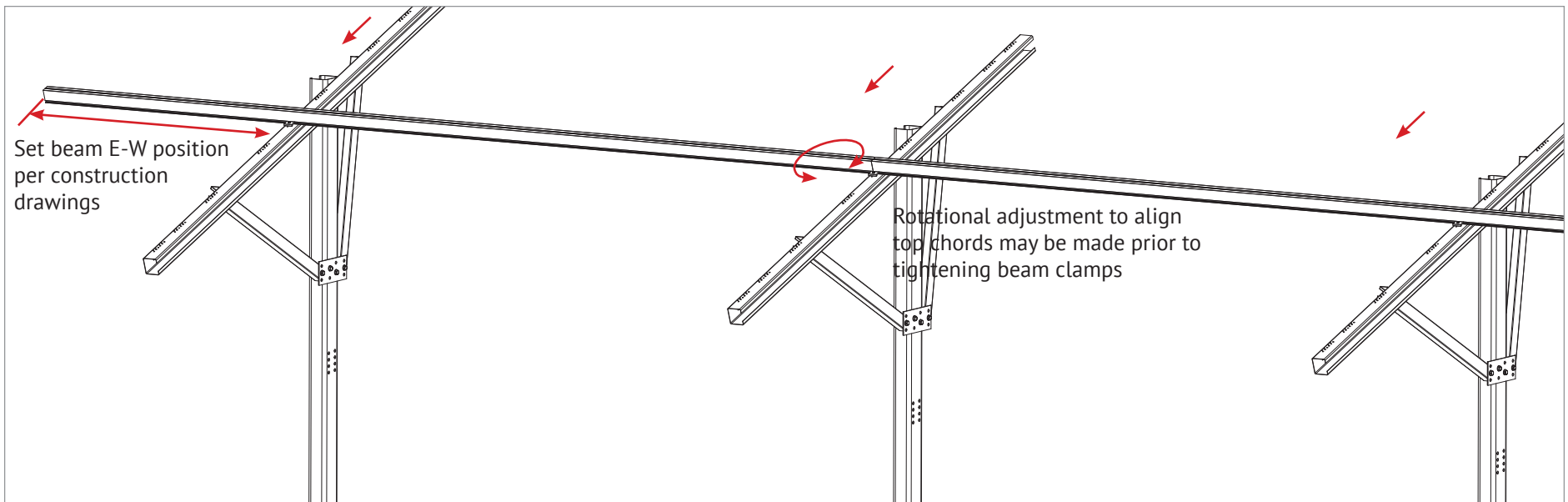
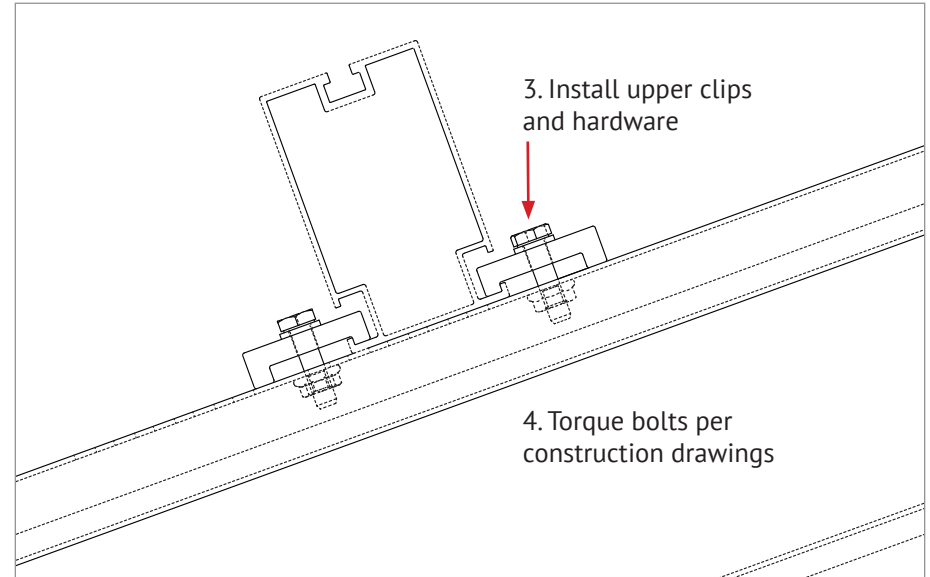
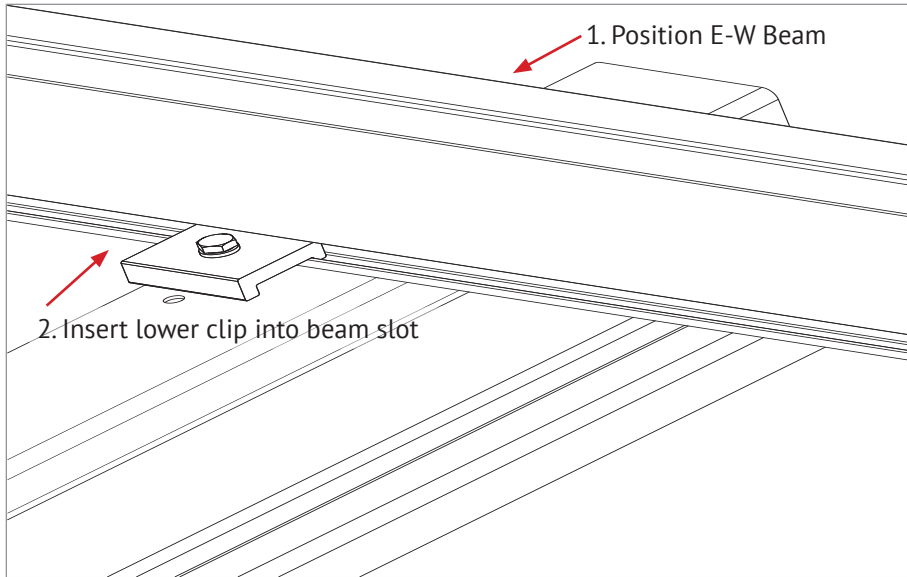

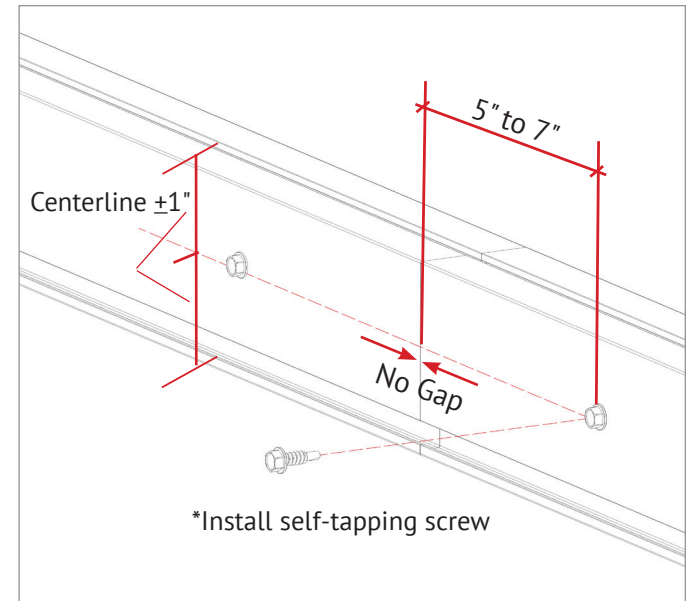
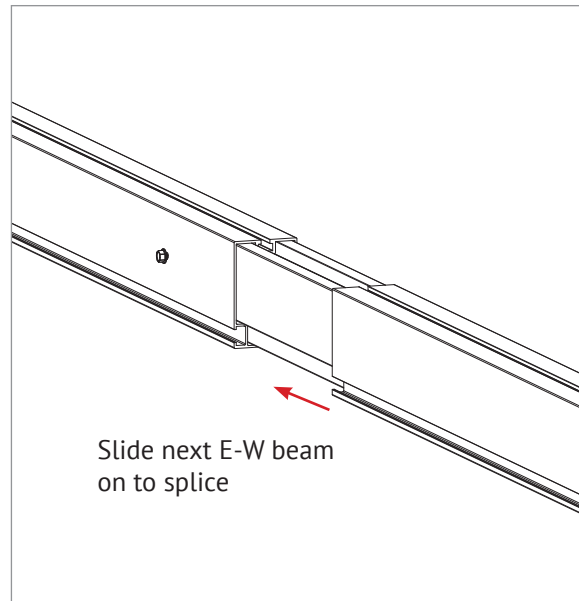
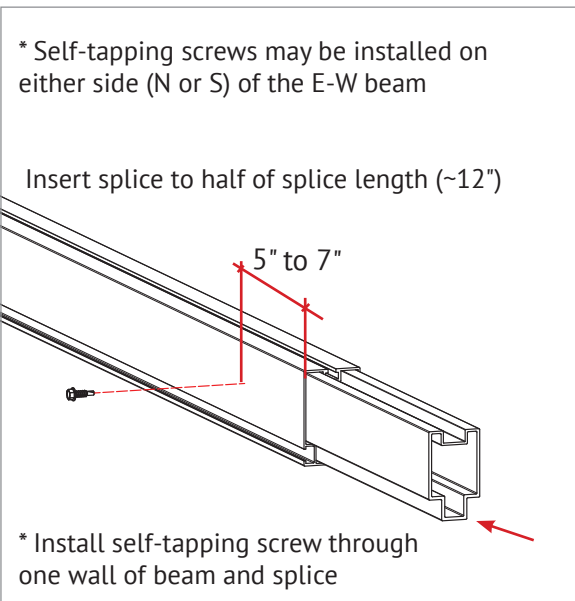
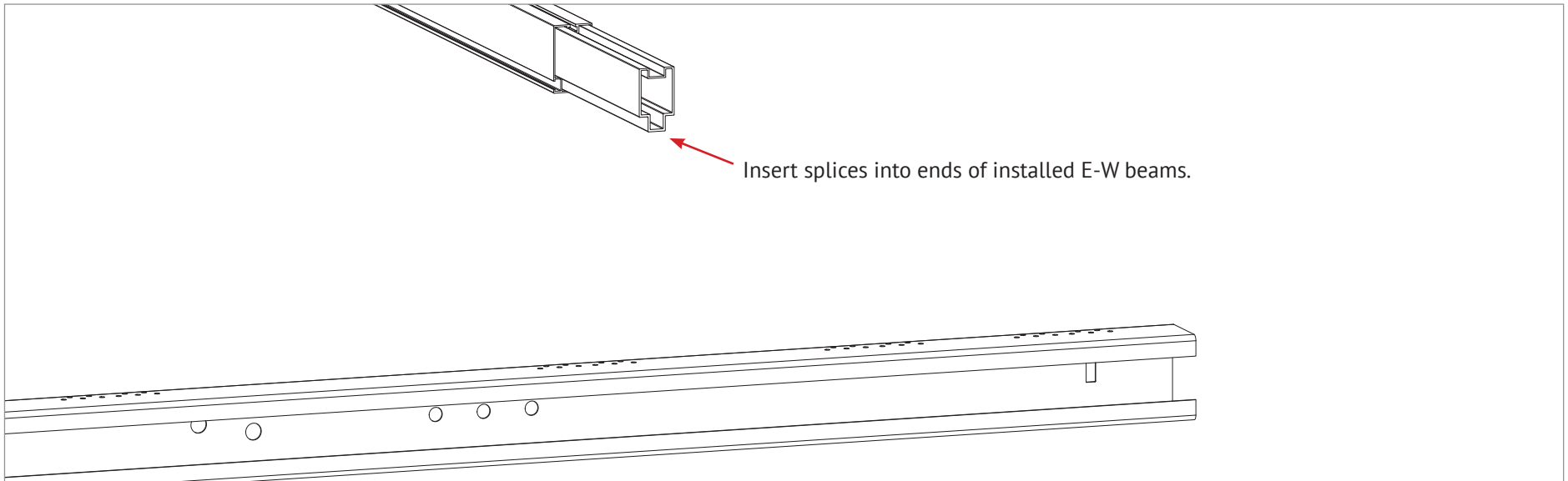

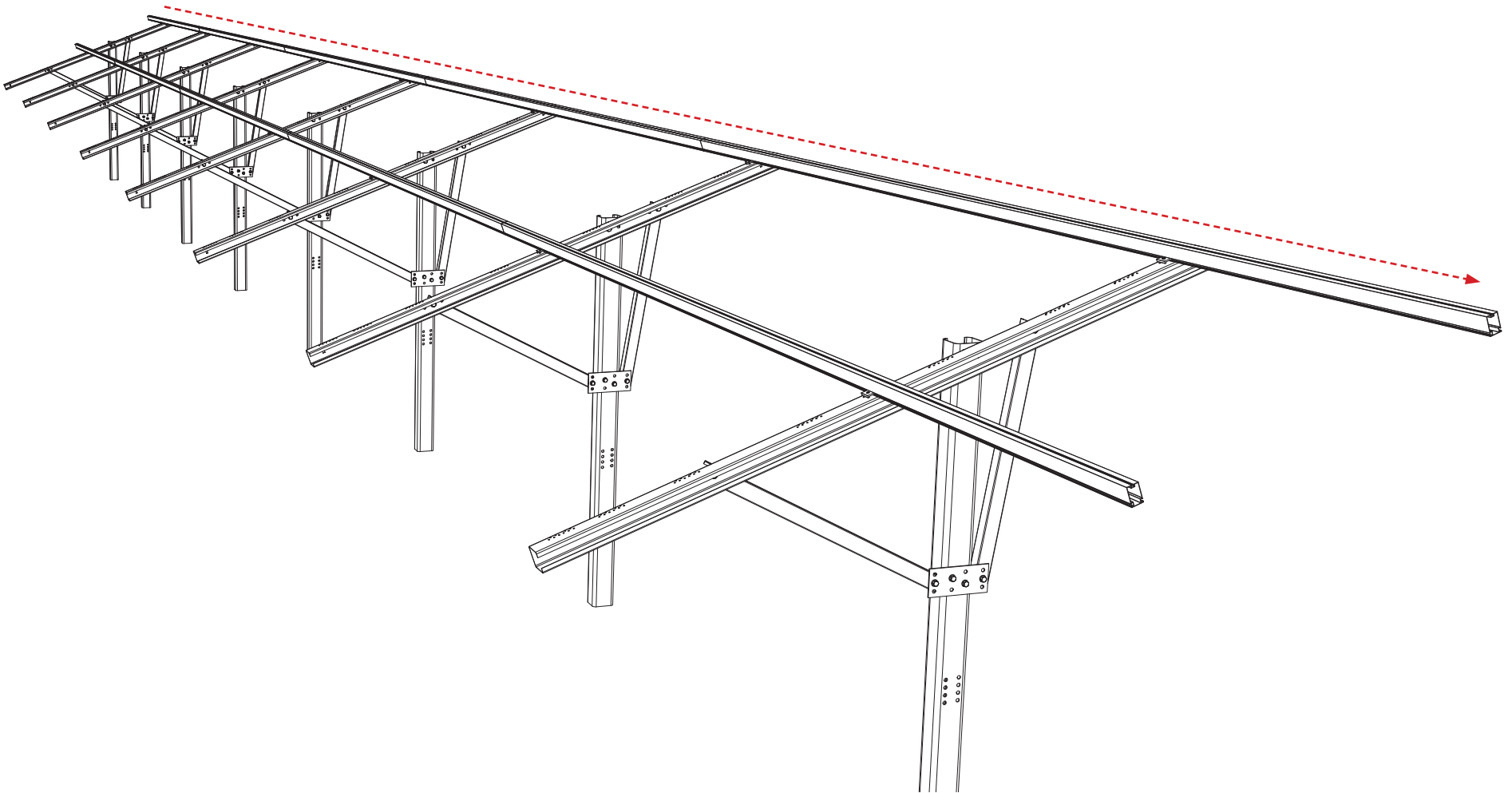

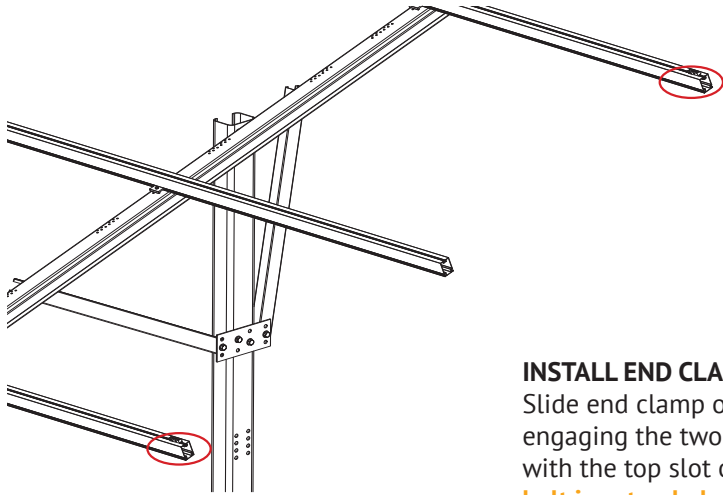

INSTALL END CLAMPS ON RAIL:
Slide end clamp on to rail by engaging the two t-guide brackets with the top slot of the rails. **Ensure bolt is extended as far as possible so that clamp is positioned at max. distance from end of rail.**

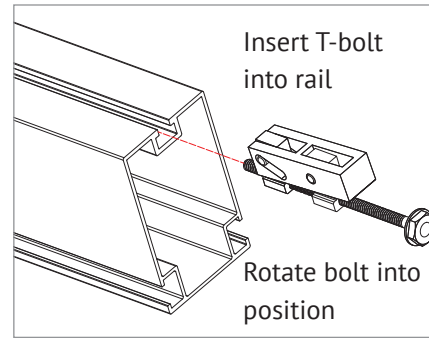

POSITION END CLAMPS:
Slide end clamp assembly on to rail until bolt head engages with end of rail. **End clamps are positioned on rails prior to the first end module and prior to the last end module.**

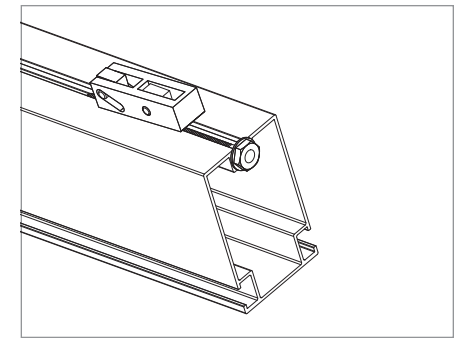

NOTE:
To assist insertion of clamp into rail slot, Pressure may be applied to top or side of bracket as shown. Do not force clamp into rail by pushing on bolt with excessive force.

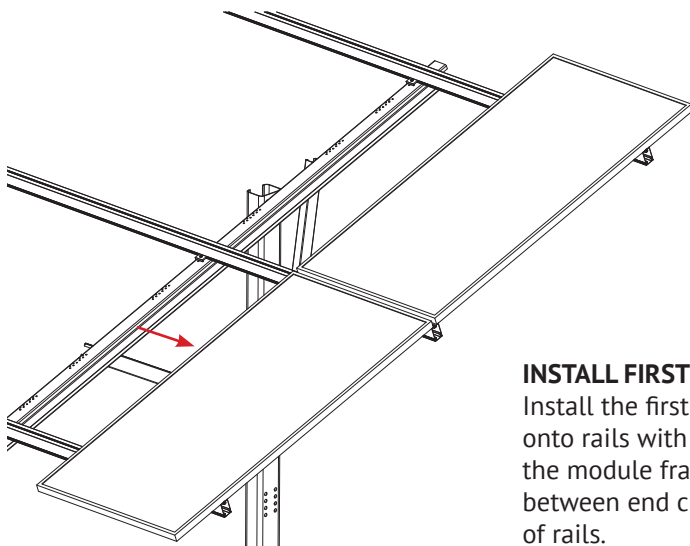

INSTALL FIRST MODULE:
Install the first end module onto rails with the flange of the module frame positioned between end clamps and ends of rails.

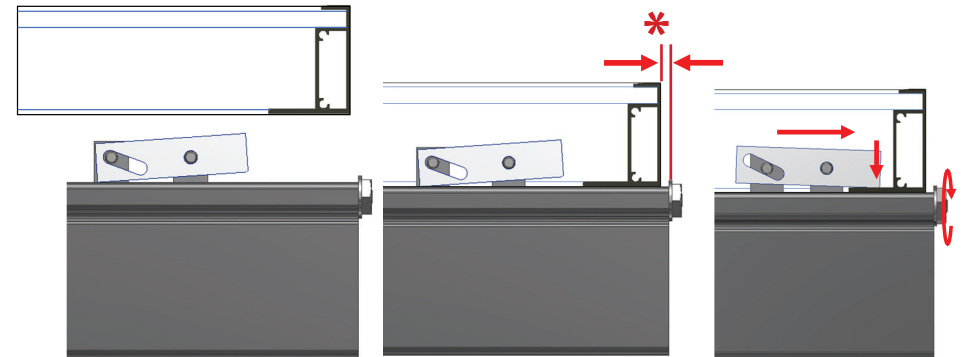

ENGAGE CLAMP:
While holding module in position and with flange in full contact with rail, rotate end clamp bolt until clamp engages with flange to provide clamp force. **To ensure bolt is not over-torqued, use low torque setting on drill or If using an impact driver, stop rotation as soon as impact action of driver begins. TORQUE VALUE (See table and notes on PG. 1) End clamp bolt to 3 ft-lbs, No anti-seize**

* Position module flush with ends of rails. Rails should not extend more than 1/2" beyond module. Module must be fully supported by rails and cannot overhang ends of rails.

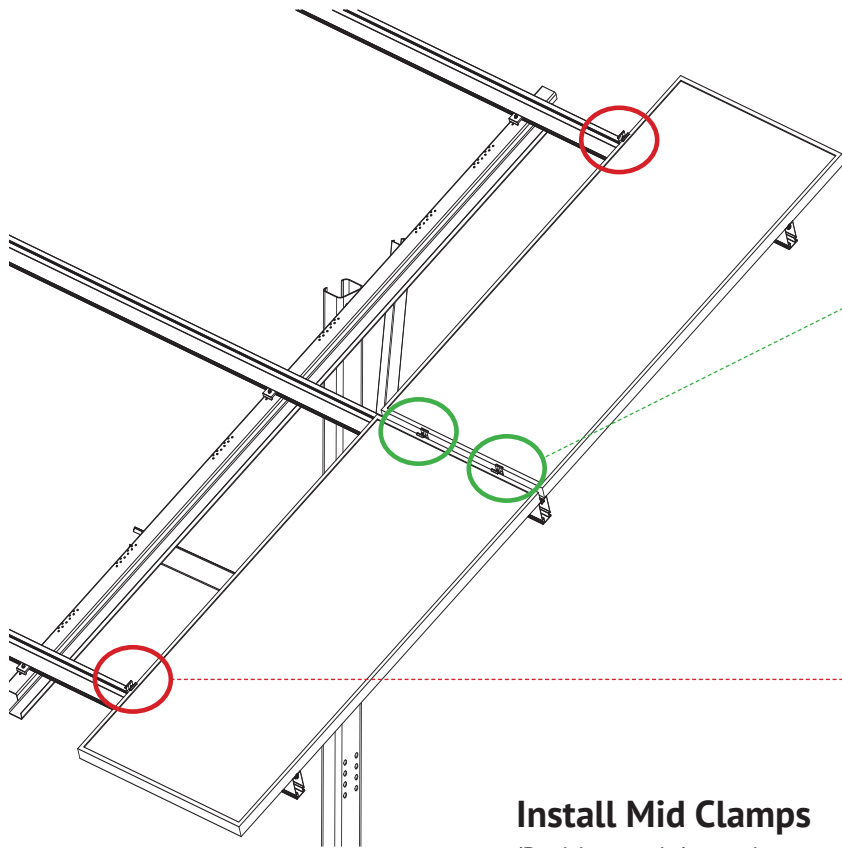

Install Mid Clamps
(Position upright against module
but do not torque)

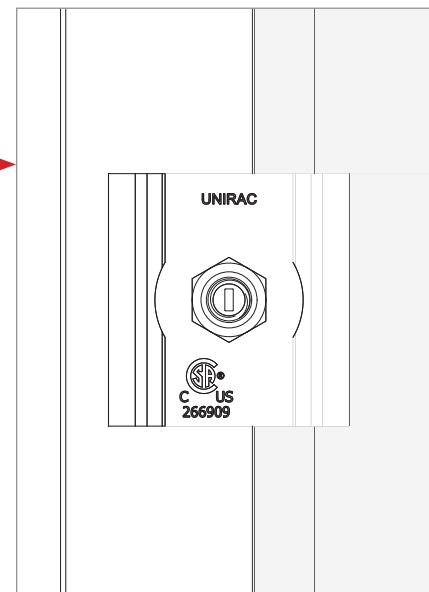
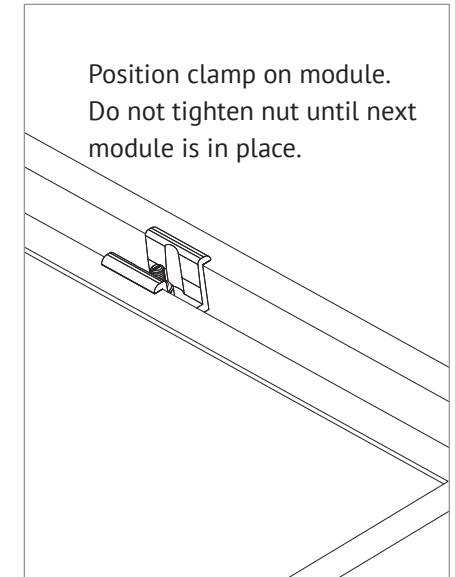
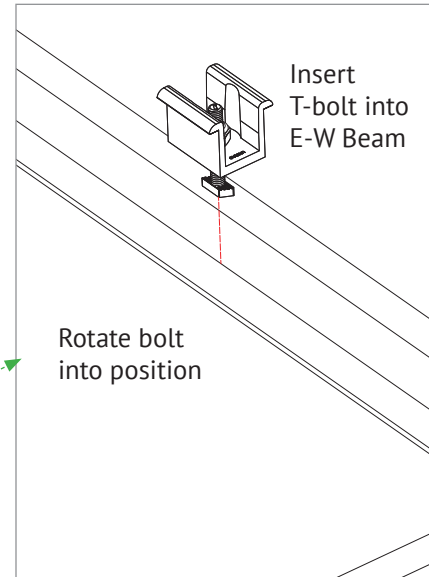

Verify that bolt position
indicator is perpendicular
to E-W beam once nut is
torqued

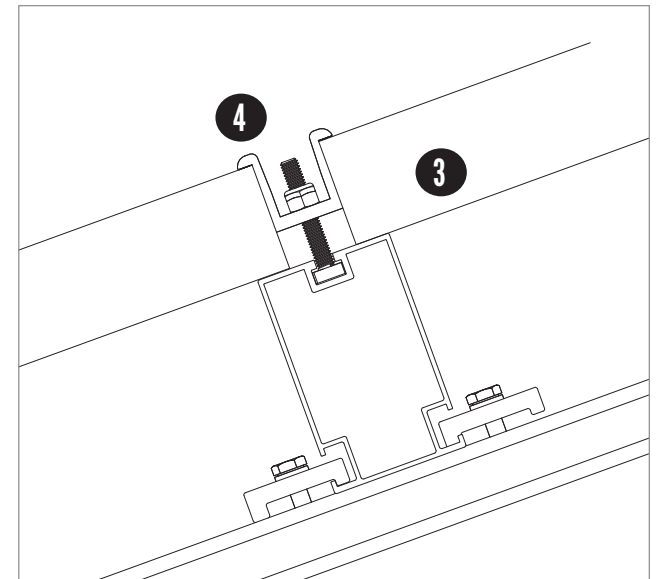
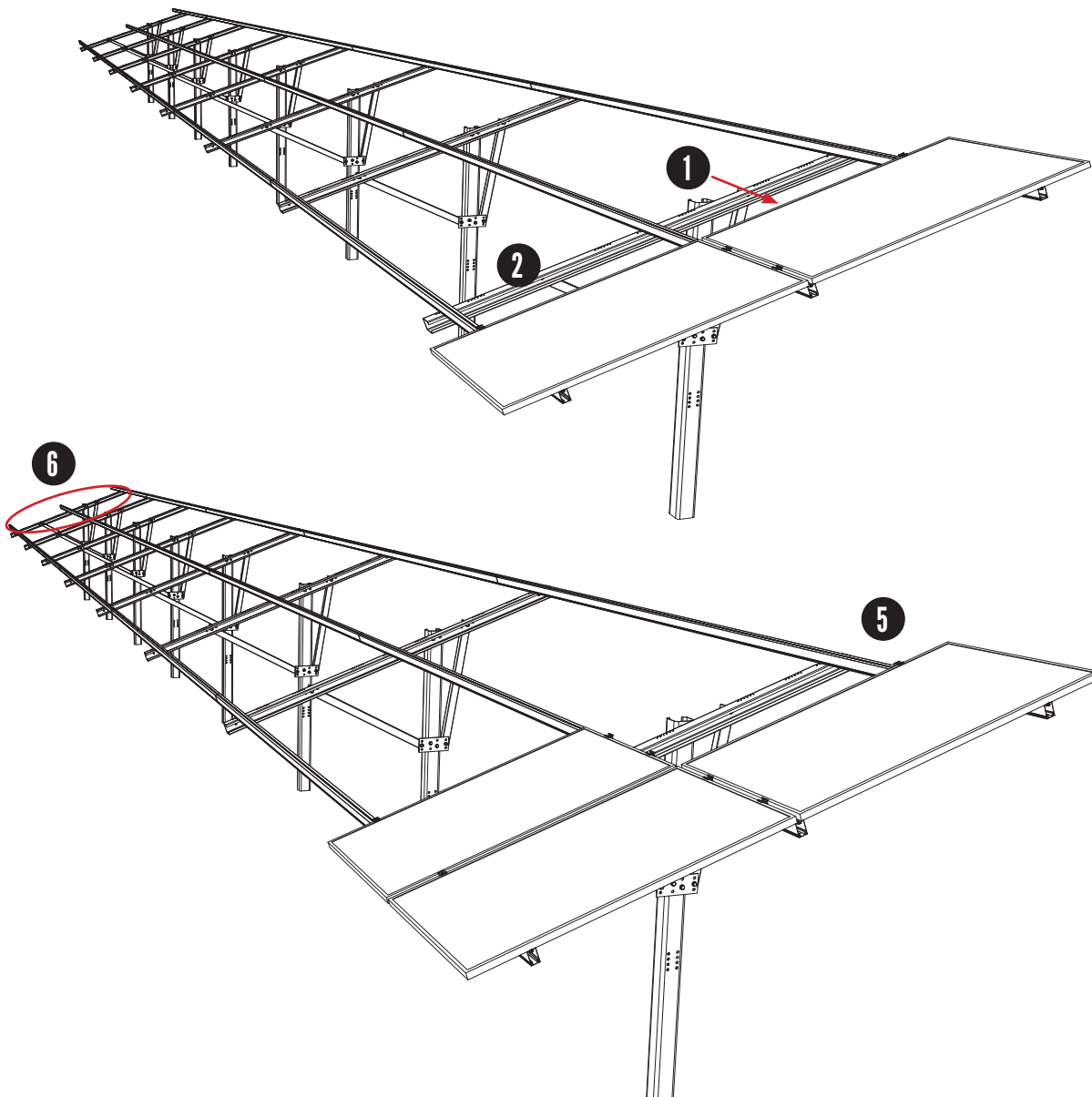

1. Place module on rails and engage with Mid Clamps
2. Align and square modules
3. Verify Mid Clamp bolt shafts are perpendicular to E-W Beam.
4. Torque nuts
5. Repeat installation of clamps and modules (Stagger the install of modules; lower-upper and repeat)
6. Install End Clamps on last module

NOTE:

The GFT system must be periodically re-inspected for loose components, loose fasteners and any corrosion, such that if found, the affected components are to be immediately replaced.

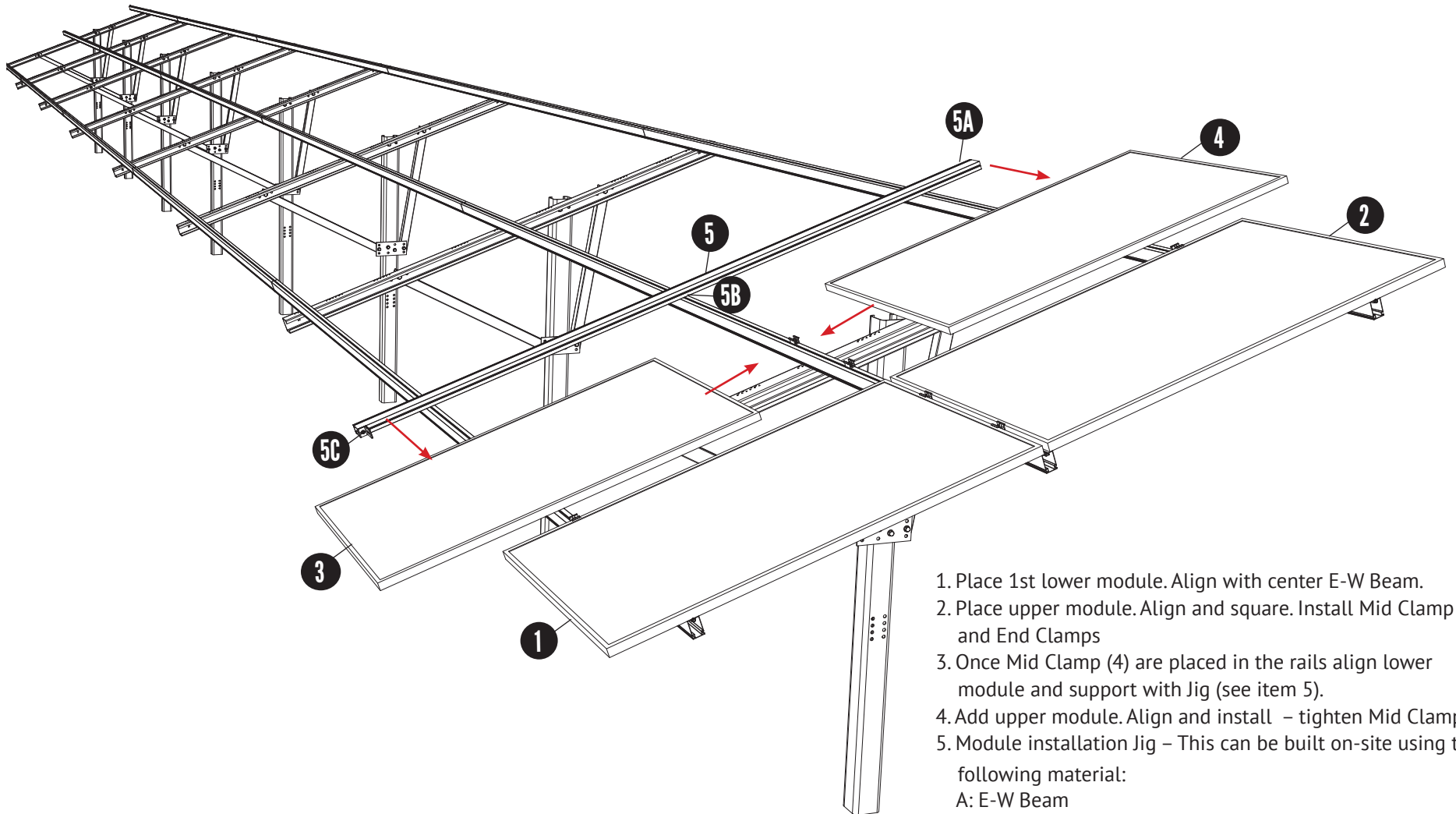

1. Place 1st lower module. Align with center E-W Beam.
2. Place upper module. Align and square. Install Mid Clamp and End Clamps
3. Once Mid Clamp (4) are placed in the rails align lower module and support with Jig (see item 5).
4. Add upper module. Align and install – tighten Mid Clamps.
5. Module installation Jig – This can be built on-site using the following material:
 - A: E-W Beam
 - B: L-Foot w/ 3/8" T-Bolt and serrate flange nut – installed in side slot
 - C: L-Foot w/ 1/4" T-Bolt or Hex Bolt and serrated flange nut – installed in top slot

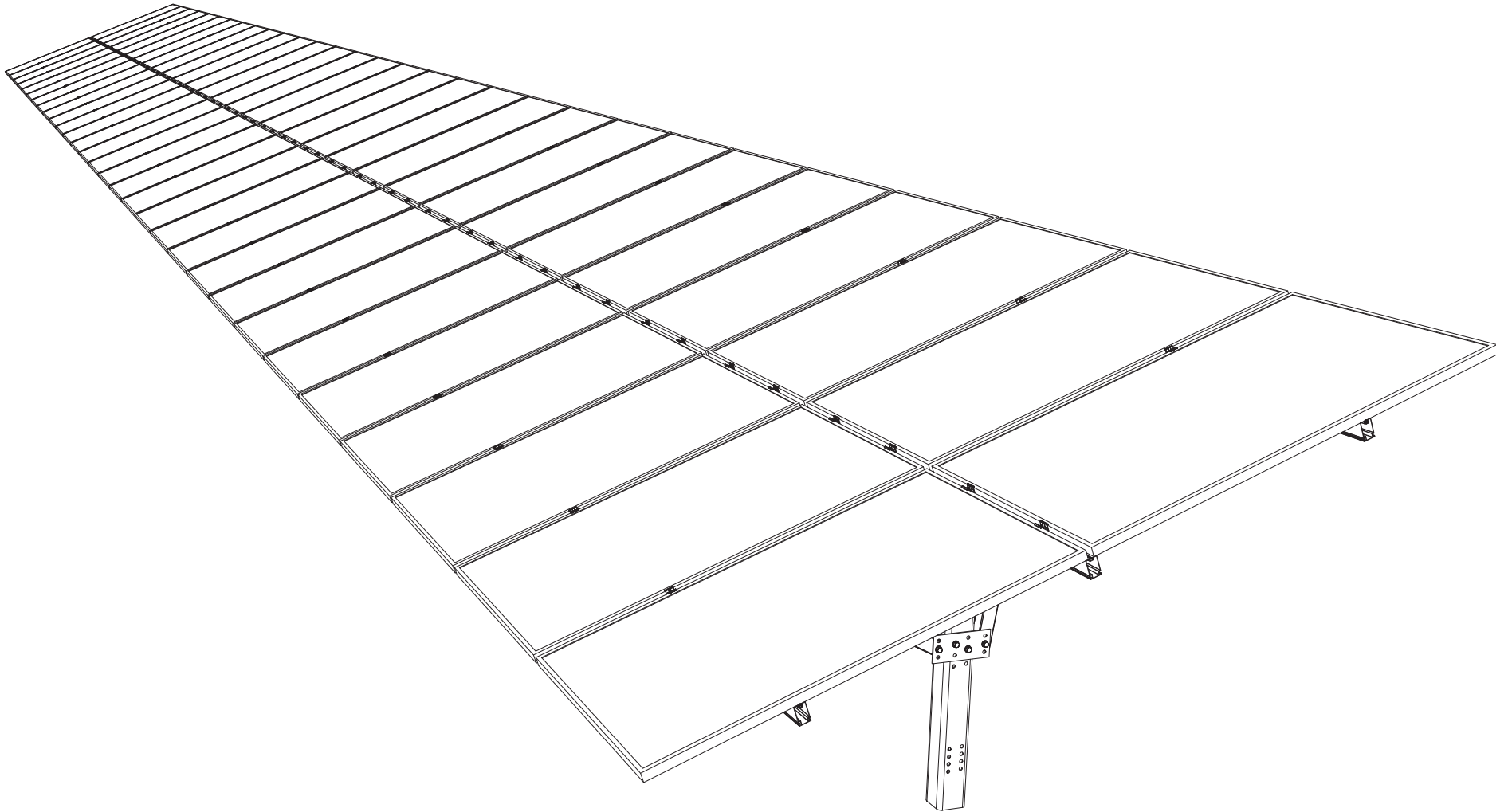

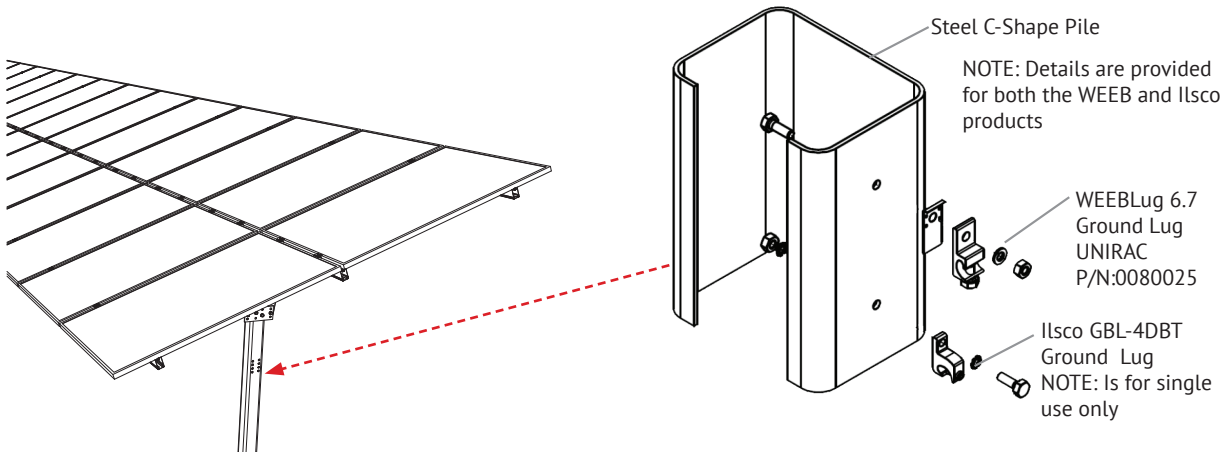

The entire Unirac GFT table has been classified for grounding & bonding to UL2703. The bonding path has been evaluated from the PV module frame all the way through to the pile. The following are suggestions to aid in grounding of the table for the project electrical engineer of record, and by the local authority having jurisdiction.

This racking system may be used to ground and/or mount a PV module complying with UL1703 only when the specific module has been evaluated for grounding and/or mounting in compliance with the included instructions.

GROUND LUG MOUNTING DETAILS

Details are provided for both the WEEB and IlSCO products. The WEEBLug has a grounding symbol located on the lug assembly. The IlSCO lug has a green colored set screw for grounding indication purposes. One lug is recommended per GFT table. Installation must be in accordance with NFPA NEC70, however the electrical designer of record should refer to the latest revision of National Electrical Code (NEC) for actual grounding conductor cable size. Unirac GFT is intended to be used with PV modules that have a system voltage less than or equal to 1,000VDC. A minimum 10AWG, 105°C copper grounding conductor should be used to ground

The following grounding & bonding components have been certified to be compatible with Unirac GFT:

- Wiley WEEBLug (P/N 0080025) Torque 1/4" mounting hardware to 10ft-lbs. See product data sheet for conductor size and conductor fastener torque.
- IlSCO Lay-in Lug (P/N GBL-4DBT) Torque 10-32 mounting hardware to 2.9ft-Lbs (35in-Lbs). See product data sheet for conductor size and conductor fastener torque.

Ground Lug	Bolt size	Drill size
WEEBLug	1/4"-20	17/64"
IlSCO	#10-32	13/64"

the system according to the (NEC) and the authority having jurisdiction. It is the installers responsibility to check local codes, which may vary. **NOTE: Any holes drilled to attach the ground lugs should be de-burred before use.**

NOTE:

Only the IlSCO GBL-4DBT ground lug is single use only, all other GFT components are multiple use.

TEMPORARY BONDING CONNECTION DURING ARRAY MAINTENANCE

When removing modules for replacement or system maintenance, any module left in place that is secured with a bonding mid-clamp will be properly grounded. If a module adjacent to the end of a row is removed, or if any other maintenance condition leaves a module without a bonding mid clamp, a temporary bonding connection must be installed as follows:

- Attach IlSCO GBL-4DBT or WeebLug 6.7 to both modules on either side of the module that has been removed. Note: The lug should be attached to the manufacturers designated grounding point on the frame.
- Install a solid #6 AWG copper wire to both grounding lugs.

NOTE:

ISOLATE COPPER FROM ALUMINUM CONTACT TO PREVENT CORROSION.

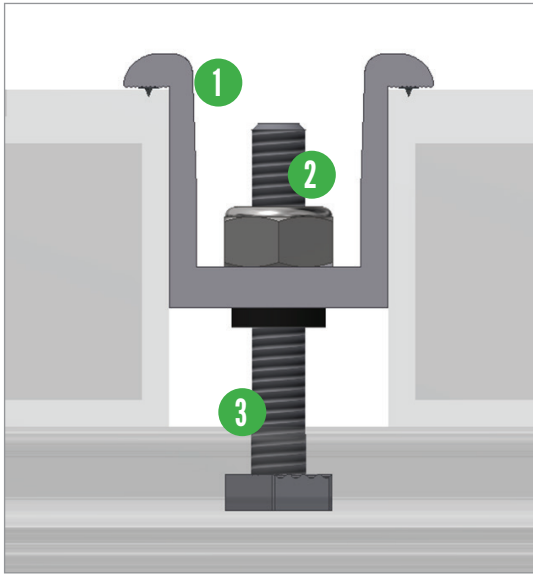

BONDING MIDCLAMP ASSEMBLY

- 1** Aluminum mid clamp with stainless steel bonding pins that pierce module frame anodization to bond module to module through clamp
- 2** Stainless steel nut bonds aluminum clamp to stainless steel T-bolt
- 3** Serrated T-bolt head penetrates rail anodization to bond T-bolt, nut, clamp, and modules to SM rail

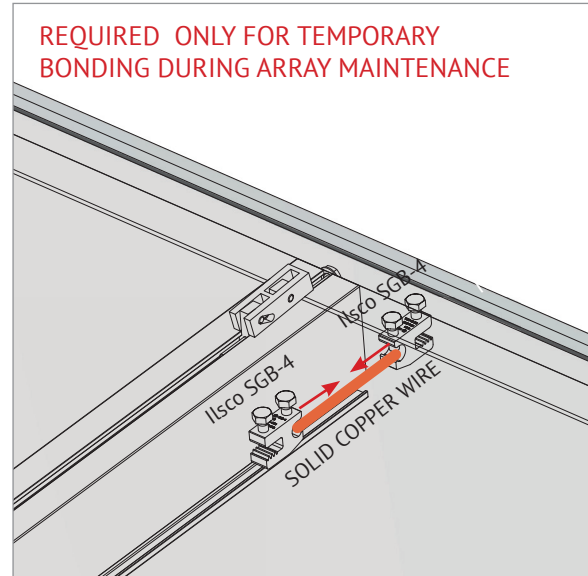

TEMPORARY BONDING CONNECTION DURING ARRAY MAINTENANCE

When removing modules for replacement or system maintenance, any module left in place that is secured with a bonding Midclamp will be properly grounded. If a module adjacent to the end module of a row is removed or if any other maintenance condition leaves a module without a bonding mid clamp, a temporary bonding connection must be installed as shown

- Attach IlSCO SGB4 to wall of GFT rail (Rail shown in picture is not a GFT rail but a representative rail for demonstration only)
- Attach IlSCO SGB4 to module frame
- Install solid #6 AWG copper wire jumper to IlSCO lugs

ELECTRICAL CONSIDERATIONS

GFT is intended to be used with PV modules that have a system voltage less than or equal to that allowable by NEC. For standard system grounding a minimum 10AWG, 105°C copper grounding conductor should be used to ground a system, according to the National Electric Code (NEC). It is the installer's responsibility to check local codes, which may vary. See below for interconnection information.

INTERCONNECTION INFORMATION

There is no size limit on how many GFT & PV modules can be mechanically interconnected for any given configuration, provided that the installation meets the requirements of applicable building and fire codes.

GROUNDING NOTES

The installation must be conducted in accordance with the National Electric Code (NEC) and the authority having jurisdiction. Please refer to these resources in your location for required grounding lug quantities specific to your project.

The grounding / bonding components may overhang parts of the array so care must be made when walking around the array to avoid damage.

Conductor fastener torque values depend on conductor size. See product data sheets for correct torque values.

Mid clamps do not need to be repositioned for re-use.

Electrical Bonding and Grounding Test Modules

The list below is not exhaustive of compliant modules but shows those that have been evaluated and found to be electrically compatible with the GROUND FIXED TILT system.

Manufacturer	Series/Model
Aleo	P18, P19, S18, S19, S59, S79
AU Optronics (BenQ Solar)	PM Series
Auxin	AXN6M610T, AXN6P610T, AXN6M612T & AXN6P612T
Axitec	AXIpower, AXIpremium, AXIblackpremium
Boviet	BVM6610 & BVM6612 Series
BYD	P6K Series & MHK-36
Canadian Solar	CS5A-M, CS6P-M, CS6P-P, CS6X-P, ELPS CS6P-MM, ELPS CS6A-MM, CS6U-P, CS6U-M, CS6K-MS, CS6K-M, CS6K-P, CS3U-P, CS3U-MS, CS3K-P, CS3K-MS, CS1K-MS, CS3W-P, CS3L-P, CS3K-MB, CS3K-PB, CS3U-MB, CS3U-PB, CS1H-MS, CS3U-MS
Centrosolar America	C-Series, E-Series
CertainTeed	CTxxxMxx-01, CTxxxP01, CTxxxMxx02, CTxxxMxx03
Eco Solargy	Orion 1000, Apollo 1000
ET Solar	ET AC Module, ET Module
Flextronics	FXS
GCL	GCL-P6 & GCL-M6 Series
Hansol	TD-AN3, TD-AN4, UB-AN1, UD-AN1
Hanwha SolarOne	HSL 60
Heliene	72M, 72P, 72M-BLK, 60M, 60P, 60M-BLK, 36M, 36P
Hyundai Heavy Industries	MG, RW, RG, KG, TG, KI, TI, RI Series
ITEK	iT HE and iT SE
JA Solar	JAP6(k)-72-xxx/4BB; JAP72SYY-xxx/ZZ; JAP6(k)-60-xxx/4BB; JAP60SYY-xxx/ZZ JAM6(k)-72-xxx/ZZ; JAM72SYY-xxx/ZZ; JAM6(k)-60-xxx/ZZ; JAM60SYY-xxx/ZZ Note: i. YY: 01, 02, 03, 09 ii. ZZ: SC, PR, BP, HiT, IB, MW YY = Backsheet, ZZ Cell technology

Jinko 60 Cell	JKMxxxP-60, JKMxxxPP-60, JKMxxx PP-60B, JKM xxx M-60, JKM xxx M-60B, JK07B (JKMSxxxPP-60), JKMxxx PP-60(Plus), JKMxxxM-60HL, JKMxxxM-60L, JKMxxxM-60BL, JK-MxxxM-60LV, JKMxxxM-60-V, JKMxxxPP-60B-J4, JKMSxxxM-60, JKMSxxxPP-60B-J4, JKMSxxxPP-60, JKMSxxxP-60, JKMxxxP-72, JKMxxxPP-72, JKMSxxx-72, JKMSxxxP-72, JK07A (JKMSxxxPP-60 & JKMSxxxPP-72), JKMxxxM-72, JKMxxxM-72-V, JKMxxxM-72L-V, JK-MxxxM-72HL-V, JKMxxx-72L-V, JKMxxxPP-72-V, JKMxxxPP-72(Plus), JKMxxxPP-72B, JKMxxxP-72B,
Kyocera	KD-F Series, KU-60 Series
LG Electronics	LGxxxN1C-G4, LGxxxN2W-G4, LGxxxN1K-G4, LGxxxS1C-G4, LGxxxS2W-G4, LGxxxQ1C(Q1K)-A5, LGxxxN1C(N1K)-A5, LGxxxS1C-A5, LGxxxN2T-A5, LGxxxN2W-A5, LGxxxS2W-A5, LGxxxE1C-A5, LGxxxN1K-V5, LGxxxE1K-A5, LGxxxN1K-V5, LGxxxN1C-V5, LGxxxQ1C-V5, LGxxxN2W-V5, LGxxxE1K-A5, LGxxxN1K-V5
LONGi	LR6-60 & LR6-72 Series
Mission Solar	MSE Mono 60, MSE Mono 72 MSE PERC 60, MSE PERC 72
Mitsubishi	MJE, MLE, NSP
Panasonic	VBHNxxxSA06, VBHNxxxSA06B, VBHNxxxSA11, VBHNxxxSA11B, VBHNxxxSA15, VBHNxxxSA15B, VBHNxxxSA16, VBHNxxxSA16B, VBHNxxxKA, VBHNxxx SA17, VBHNxxxSA18, VBHNxxxKA03/04, VBHNxxxSA17G/17E, VBHNxxxSA18E
Peimar	SGxxxM, SGxxxM (BF), SGxxxM (FB)
Phono Solar Technology	All Standard Modules

The modules selected for UL 2703 bonding and grounding testing represent the broadest possible range of modules on the market. The tests were performed for each specific bonding location using representative module frame profile sections. The tests performed cover the following basic module parameters:

- The frame profile must not have any feature that might interfere with the bonding devices that are integrated into the racking system
- Use with a maximum over current protection device OCPD of 30A

Electrical Bonding and Grounding Test Modules

The list below is not exhaustive of compliant modules but shows those that have been evaluated and found to be electrically compatible with the GROUND FIXED TILT system.

Manufacturer	Series/Model
Q-Cells	Q.PEAK BLK G4.1 & Q.PEAK G4.1 Q.PLUS BFR G4.1/TAA, Q.PLUS BFR G4.1/MAX B.LINE PLUS BFR G4.1, B.LINE PRO BFR G4.1 Q.PRO EC-G4.4 Q.PEAK-G3.1, Q.PEAK BLK G3.1, Q.PLUS BFR G3.1 Q.PLUS G3, Q.PRO G3, Q.PRO BFR-G3, Q.PEAK-G3, Q.PEAK BLK-G3 Q.PEAK-G3.1, Q.PEAK BLK-G3.1, Q.PLUS BFR G3.1, Q.PLUS-G3, Q.PRO G3, Q.PRO BFR-G3, Q.PEAK-G3, Q.PEAK BLK-G3, Q.PLUS BFR G4.1, Q.PRO BFR G4, Q.PRO BFR G4.1, Q.PEAK-G4.1, Q.PEAK-G4.1/MAX, Q.PEAK BLK G4.1, Q.PRO G4, Q.PLUS G4, Q.PEAK-G4.1/TAA, Q.PEAK BLK G4.1/TAA, Q.PLUS BFR G4.1/TAA, Q.PLUS BFR G4.1/MAX, B.LINE PLUS BFR G4.1, B.LINE PRO BFR G4.1, Q.PRO BFR G4.3, Q.PRO EC-G4.4, Q.PRO L-G2, Q.PEAK L G4.2, Q.PLUS L G4.2, Q.PLUS L G4.1, Q.PLUS L G4, Q.PRO L G4, Q.PRO L G4.1, Q.PRO L G4.2, B.LINE PLUS L G4.2, B.LINE PRO L G4.1, B.LINE PRO L G4.2, Q.PLUS L-G4.2/TAA, Q.PEAK DUO-G5, DUO BLK-G5 Q.PEAK DUO L-G5.2, Q.PEAK DUO L-G5.3, Q.Peak Duo L-G6, Q.Peak Duo L-G6.2, Q.Peak Duo L-G6.3, Q.Peak Duo G6, Q.Peak Duo BLK-G6
REC	RECxxxTP72, RECxxxTP RECxxxPE72, RECxxxPE RECxxxTP2S72, RECxxxTP2 BLK2, RECxxxTP2 RECxxxNP (N-PEAK)
Renesola	All 60-cell modules
Risen	RSM144-6, RSM72-6 (MDG) (M), RSM60-6
Seraphim	SEG-6PA, SEG-6PB, SEG-6MA, SEG-6MB, SEG-E01, SEG-E11, SRP-6QA, SRP-6QB (40mm only)
Sharp	ND240QCJ, ND240QCS, NDQ235F4 NU-SA & NU-SC

S-Energy	SN72 & SN60 Series
Silfab	SLAXXXM, SLAXXXP, SLGXXXP, SLGXXXM
Solaria	PowerXT
Solartech	STU-XXX HJT, b. STU-XXX PERC, Quantum PERC
SolarWorld	SunModule Protect, SunModule Plus, SunModule Pro
Sun Edison / MEMC	F-Series, R-Series
Suniva	MV Series, OPTIMUS Series
SunPower	AC, E-Series, Sig Black, X-Series P-Series
Suntech	STP "XXX"
Talesun	TP672, TP660, TP572, TP596, Hipor M350, Smart
Trina	PD05, PA05, DD05, DD14, PE14, PD14, DE14
TSMC Solar	TS-150C2 CIGS
UpSolar	60 and 72 cell modules
Vikram Solar	Grand Ultima Silver 40mm, Ultima Silver 40mm, Grand Ultima 40mm, Grand Ultima Silver 40mm, Ultima Silver 40mm
Winaico	WST, WSP
Yingli	Panda 60, YGE 60, YGE-Z 60 YGE-U72 YLM60 & YLM 72 YLM-VG

The modules selected for UL 2703 bonding and grounding testing represent the broadest possible range of modules on the market. The tests were performed for each specific bonding location using representative module frame profile sections. The tests performed cover the following basic module parameters.

Appendix	Table of Contents
Appendix A	END & MID CLAMP ASSEMBLIES – ENHANCED CLAMPS
Appendix B	INSTALL MODULE W/END CLAMPS – ENHANCED CLAMPS
Appendix C	INSTALL MID CLAMPS ON 1ST MODULE – ENHANCED CLAMPS

Mid Clamp Assembly with T-Bolt

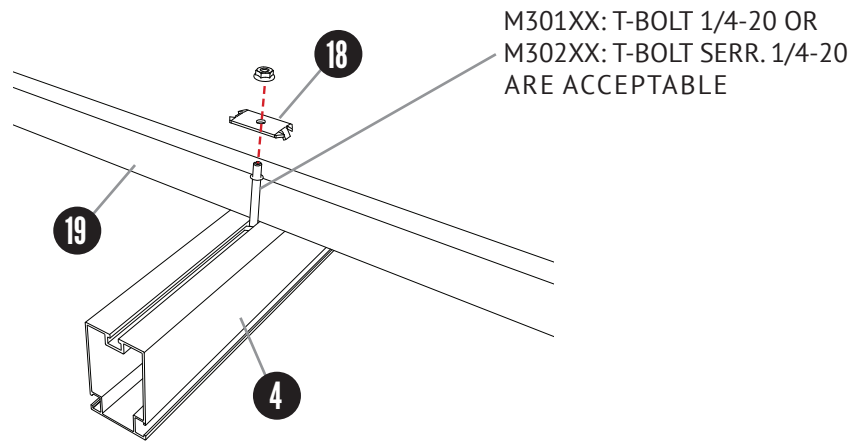

End Clamp Assembly with T-Bolt

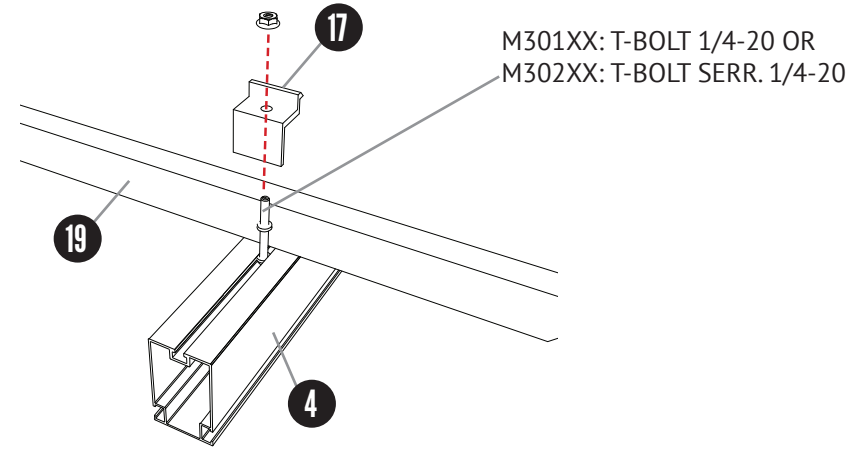

Mid Clamp Assembly With T-Bolt

ITEM	COMPONENT	MATERIAL
4	3.25" x 2" East-West Aluminum Beam	Aluminum Alloy 6005A-T61, 6351-T5 or 6061-T6, Fy = 35 ksi, Ft _u = 38 ksi
18	Mid Clamp	Stainless Steel, 301,302, or 304, 1/4 Hard, Mill Finish
19	PV Module (By Others)	As per Manufacturer
SEE DWG	1/4-20 T-Bolt (Serrated or Non-Serrated)	300 Stainless Steel (301 Preferred) with Min Ft _u = 70 ksi
SEE DWG	1/4-20 Serrated Flange Nut	Stainless Steel ASTM F594 with Min Ft _u = 70 ksi

End Clamp Assembly With T-Bolt

ITEM	COMPONENT	MATERIAL
4	3.25" x 2" East-West Aluminum Beam	Aluminum Alloy 6005A-T61, 6351-T5 or 6061-T6, Fy = 35 ksi, Ft _u = 38 ksi
17	End Clamp	Stainless Steel, 301,302, or 304, 1/4 Hard, Mill Finish
19	PV Module (By Others)	As per Manufacturer
SEE DWG	1/4-20 T-Bolt (Serrated or Non-Serrated)	300 Stainless Steel (301 Preferred) with Min Ft _u = 70 ksi
SEE DWG	1/4-20 Serrated Flange Nut	Stainless Steel ASTM F594 with Min Ft _u = 70 ksi

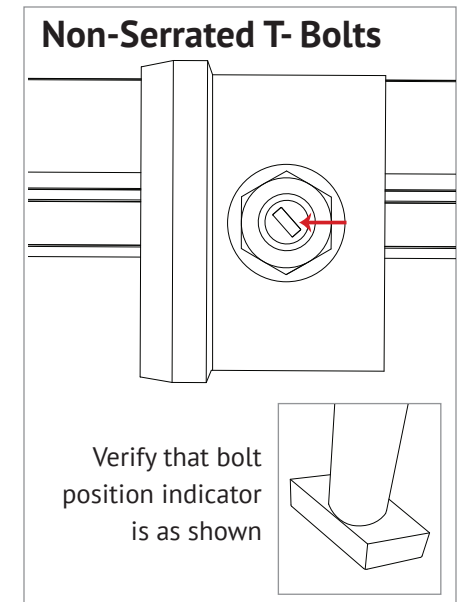
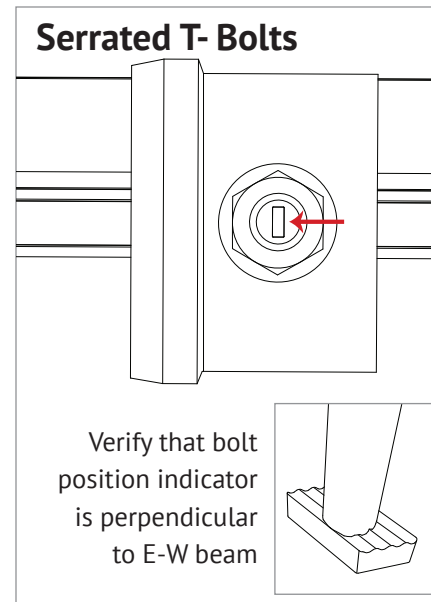
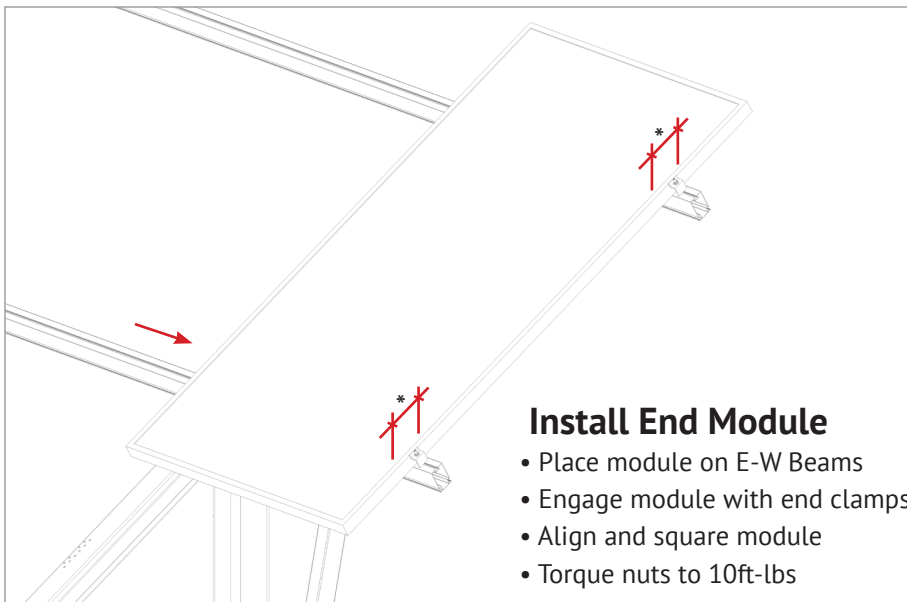
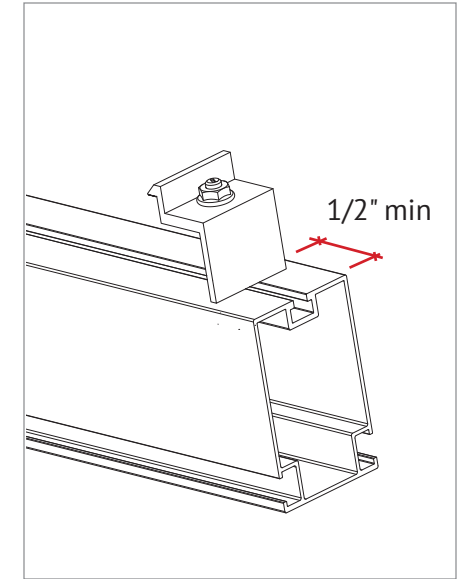
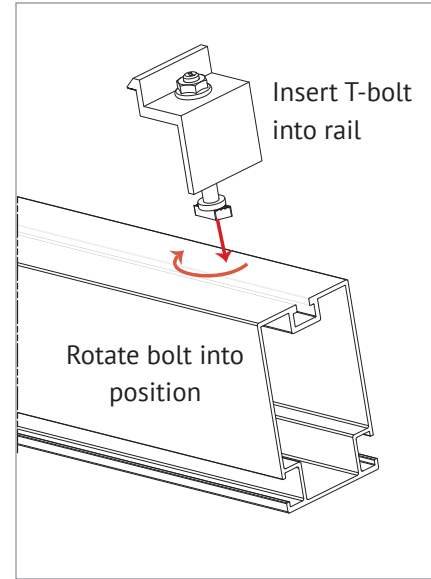
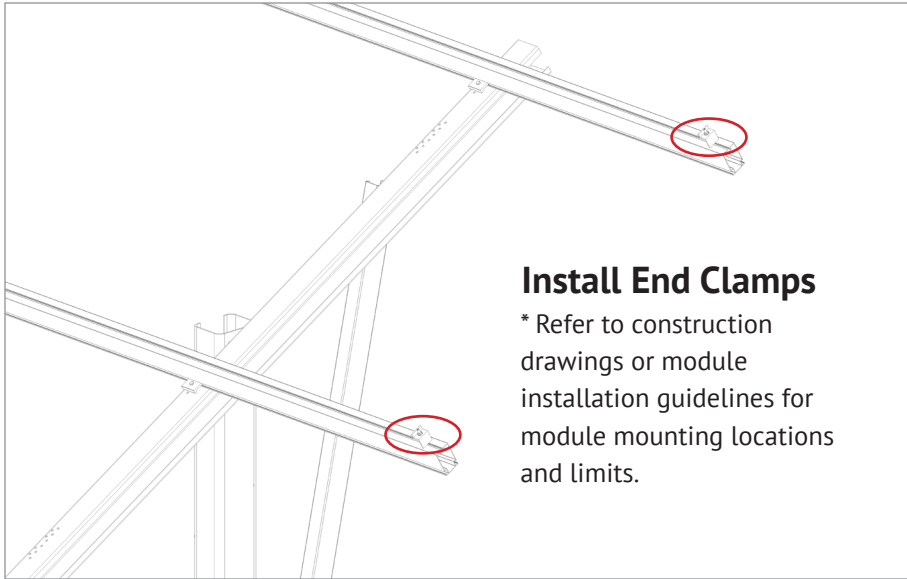

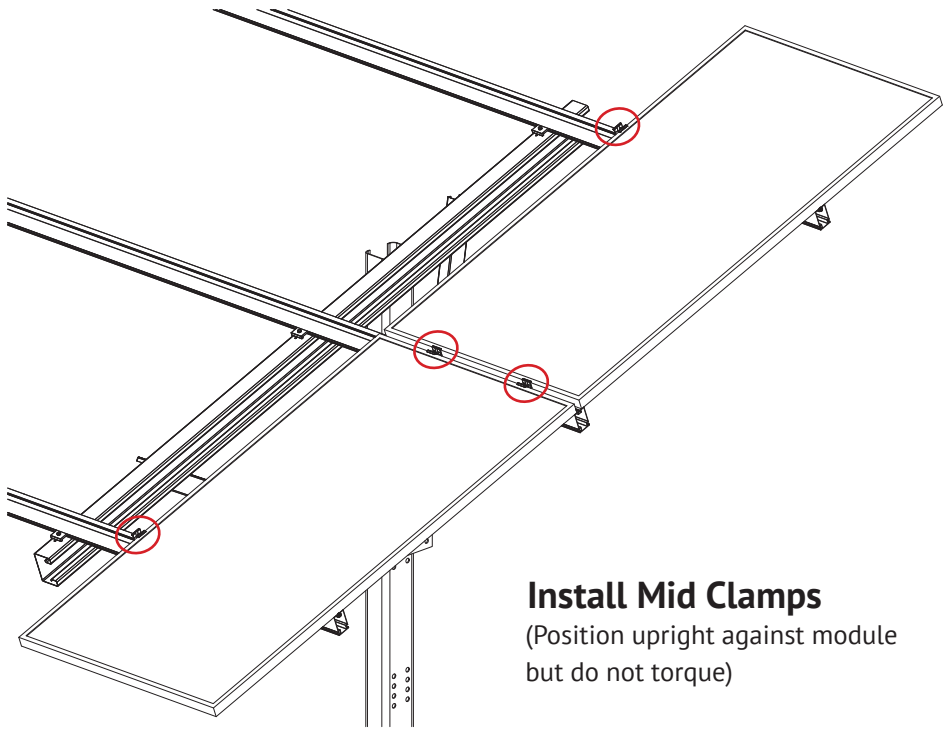

Install Mid Clamps
(Position upright against module
but do not torque)

