



GaBi Databases & Modelling Principles



Authors:

Dr. Thilo Kupfer, Dr. Martin Baitz, Dr. Cecilia Makishi Colodel, Morten Kokborg, Steffen Schöll, Matthias Rudolf, Dr. Ulrike Bos, Fabian Bosch, Maria Gonzalez, Dr. Oliver Schuller, Jasmin Hengstler, Alexander Stoffregen, Daniel Thylmann, Dr. Chris Koffler

With contributions of the Sphera expert teams:

Energy, Transport, Metals, Chemistry, Construction, Renewables, Electronics, End-of-Life, Plastics, Coating and textiles, Water.



www.sphera.com

www.gabi-software.com

For more information contact us at:

<https://sphera.com/contact-us>

© 2021 Sphera. All Rights Reserved.

List of Contents

List of Contents	III
List of Figures	VI
List of Tables	VIII
Abbreviations	IX
1 Introduction and Aim of Document	1
2 GaBi Database Framework	3
2.1 GaBi Database concept and management	3
2.2 GaBi Database development, maintenance and update	6
2.3 Structure of the Master Database contents	8
2.4 Standardisation, conformance and application of LCI databases....	15
2.5 Databases in reference networks, standards and principles	16
2.6 GaBi LCI Teams	18
3 Methodological Framework	20
3.1 Definition of tasks in database work	20
3.2 Goal.....	21
3.3 Scope	21
3.3.1 <i>Function and Functional Unit</i>	22
3.3.2 <i>Definition of terms within system boundaries</i>	22
3.3.3 <i>System boundaries for the creation of standard LCI cradle to gate datasets</i>	24
3.3.4 <i>Cut-offs</i>	31
3.3.5 <i>Gap closing</i>	33
3.3.6 <i>Infrastructure</i>	33
3.3.7 <i>Transportation</i>	36
3.3.8 <i>Water</i>	37
3.3.9 <i>Wastes and recovered material or energy</i>	44
3.3.10 <i>Radioactive waste and stockpile goods</i>	45
3.3.11 <i>Selected aspects of biomass modelling</i>	47
3.3.12 <i>Aspects of primary energy of fossil and renewable energy sources</i>	56
3.3.13 <i>Land Use using the LANCA® method</i>	57
3.3.14 <i>Land Use Change (LUC)</i>	59
3.4 Sources and types of data	64
3.4.1 <i>Primary and secondary sources of data</i>	64
3.4.2 <i>Unit process and aggregated data</i>	66
3.4.3 <i>Units</i>	69

3.4.4	<i>LCI data and supported LCIA methods</i>	70
3.4.5	<i>Production and consumption mix</i>	71
3.5	Data quality approach	73
3.5.1	<i>Decision context</i>	74
3.5.2	<i>Data Quality Indicators (DQIs)</i>	75
3.5.3	<i>Reproducibility, Transparency, Data aggregation</i>	89
4	System Modelling Features	92
4.1	Data collection	92
4.1.1	<i>Quality check and validation of collected data</i>	93
4.1.2	<i>Treatment of missing data</i>	93
4.1.3	<i>Transfer of data and nomenclature</i>	94
4.2	Geographical aspects of modelling	96
4.3	Parameter	97
4.4	Multifunctionality and allocation principle	97
4.5	Generic Modules as background building block	99
4.6	Special modelling features for specific areas.....	99
4.6.1	<i>Energy</i>	100
4.6.2	<i>Transport</i>	106
4.6.3	<i>Mining, metals and metallurgy</i>	114
4.6.4	<i>Chemistry and plastics</i>	116
4.6.5	<i>Construction</i>	121
4.6.6	<i>Renewables</i>	141
4.6.7	<i>Electronics</i>	141
4.6.8	<i>Recycling and other End-of-Life treatments</i>	145
5	Review, documentation and validation	153
5.1	Review procedures and check routines	153
5.1.1	<i>Technical information and documentation routines in GaBi</i>	154
5.1.2	<i>Important material and energy balances</i>	154
5.1.3	<i>Plausibility of emission profiles and avoiding errors</i>	155
5.2	Documentation.....	156
5.2.1	<i>Nomenclature</i>	156
5.2.2	<i>Documentation of Flows</i>	157
5.2.3	<i>Documentation of LCI process data</i>	158
5.3	Validation	160
6	Literature	162
7	Appendix A Description of result and impact categories	169

7.1	Primary energy consumption	173
7.2	Waste categories	174
7.3	Climate Change – Global Warming Potential (GWP) and Global Temperature Potential (GTP).....	174
7.4	Acidification Potential (AP).....	180
7.5	Eutrophication Potential (EP)	183
7.6	Photochemical Ozone Creation Potential (POCP).....	186
7.7	Ozone Depletion Potential (ODP).....	188
7.8	Human and eco-toxicity	191
7.9	Resource depletion	195
7.10	Land Use.....	198
7.11	Water use.....	199
7.12	Particulate matter formation (PM).....	202
7.13	Odour potential.....	202
7.14	Normalization	203
7.15	Weighting.....	203
8	Appendix B List of active methods and impact categories	206
9	Appendix C Background information on uncertainty	214

List of Figures

Figure 2-1:	GaBi Database concept embedded in a three-pillar approach	3
Figure 2-2:	Database Management at Sphera	6
Figure 2-3:	Hierarchical structure of the processes and plans	8
Figure 2-4:	Aggregated dataset in GaBi, illustrative example	9
Figure 2-5:	Polymerisation subsystem in GaBi Master DB	10
Figure 2-6:	Tetrafluoroethylene subsystem in GaBi Master DB	10
Figure 2-7:	R22 subsystem in GaBi Master DB	11
Figure 2-8:	Chlorine production mix in GaBi Master DB	11
Figure 2-9:	Chlorine membrane technology production in GaBi Master DB	12
Figure 2-10:	Refinery model in GaBi Master DB	12
Figure 2-11:	Crude oil import mix and country specific oil extraction in GaBi Master DB	13
Figure 2-12:	Example of a country-specific grid mix model in the GaBi Master DB	14
Figure 2-13:	German natural gas consumption mix in GaBi MasterDB	14
Figure 2-14:	German natural gas production in GaBi MasterDB	15
Figure 2-15:	GaBi DB in the international context of databases and frameworks	17
Figure 2-17:	Turning standards into technology solutions	17
Figure 2-18:	GaBi LCI industry sector Expert Teams and the core GaBi Data “Content” team	19
Figure 2-19:	Overview of relevant data sources consistently covered in GaBi Databases	19
Figure 3-1:	Graphic representation of different (sub-) system boundaries	23
Figure 3-2:	Generic example product system of a dataset development standard [ISO 14040: 2006],	24
Figure 3-3:	Application of water flows in open-loop and closed-loop cooling systems	41
Figure 3-4:	Application of water flows in in electricity generation	42
Figure 3-5:	Application water flows in hydropower generation	43
Figure 3-6:	Ad hoc example of a simple plan system including different processes and water flows	43
Figure 3-7:	CO ₂ removals	48
Figure 3-8:	Exemplary flow properties	50
Figure 3-9:	Basic concept of the carbon correction in GaBi	50
Figure 3-10:	Carbon correction formula	51
Figure 3-12:	Balance view for carbon correction I	52
Figure 3-13:	Balance view for carbon correction II	53
Figure 3-14:	CO ₂ correction process - parameters	53
Figure 3-15:	Example of different biotic carbon flows in GaBi	62
Figure 3-16:	Example of methane biotic emissions to air	62
Figure 3-17:	Example of LUC emissions occurring with additional LUC flows	63

Figure 3-18:	Example of LUC emissions occurring without an additional LUC flow as fossil CO ₂	64
Figure 3-19:	Difference between “production mix” and “consumption mix” (for power generation)	72
Figure 3-20:	Overall data quality according to ILCD assessment scheme [ILCD 2011]. This follows partly a more robust “weakest link in the chain” logic, that the poorest data aspect downgrades the overall quality (as it has a higher weight assigned).	87
Figure 3-21:	Overall data quality according to EF assessment scheme [PEF guide 2013]	87
Figure 3-22:	Overview of the six GaBi DQIs and the criteria for the assessment of datasets	88
Figure 3-23:	Screenshot of a dependent internal review including the DQIs	89
Figure 3-24:	Principle graphical explanation of the relation of completeness, precision	90
Figure 4-1:	Hierarchical structure of the processes and plans	96
Figure 4-2:	Conventional natural gas production in Germany	101
Figure 4-3:	Natural gas supply for Germany	101
Figure 4-4:	US, East electricity grid mix	103
Figure 4-5:	Parameterized US Coal gas CHP power plant	104
Figure 4-6:	Principle known functions of tropospheric ozone creation and reduction	110
Figure 4-7:	Excerpt of the organic network ^{1F} considered in GaBi	117
Figure 4-8:	Consumption mix of Epoxy resin in Germany	119
Figure 4-9:	Example of PVC resin – compound- part	121
Figure 4-10:	Schematic life cycle of a building	122
Figure 4-11:	Life cycle stage modules according to EN 15804+A2 (2019)	124
Figure 4-12:	Creation of a model for an electronic product – modular structure via Generic Modules	143
Figure 4-13:	Exemplary incineration model with in GaBi (here average European domestic waste treatment with dry off-gas cleaning)	147
Figure 4-14:	Details of incineration and dry off-gas cleaning in GaBi incineration model	148
Figure 4-15:	Exemplary landfill model in GaBi (here commercial waste composition for certain geographic example regions)	149
Figure 4-16:	Exemplary wastewater treatment model in GaBi (here municipal wastewater for German setting)	151
Figure 5-1 :	Example documentation in GaBi (excerpt) [GABI]	159

List of Tables

Table A:	Background system boundaries	24
Table B:	Relevance of infrastructure for a natural gas power plant in the GaBi Master DB	35
Table C:	Publicly available example value for a medium size gas power plant	35
Table D:	Publicly available example values for CO ₂ for a gas power plant	36
Table E:	Changes in water flows in GaBi (regionalisation of flows is not depicted in this table)	39
Table F:	Definitions of the radioactive waste flows in GaBi	45
Table G:	Definitions of the Stockpile goods elementary flows in GaBi	46
Table H:	Default treatment procedures for common materials/wastes	47
Table I:	General procedure for some hazardous waste flows	47
Table J:	Overview of qualitative importance of “quality indicators” in GaBi DBs	73
Table K:	Coefficients of variation, from a case study	84
Table L:	LCIA GWP methods with primary sources	169
Table M:	EF 2.0: set of recommended impact methods	171
Table N:	EF 3.0: set of recommended impact methods	172
Table O:	Net and gross calorific value	174
Table P:	Global warming incl. and excl. biogenic carbon, land use and aviation	176
Table Q:	Normalization references	203
Table R:	thinkstep Weighting 2012	204
Table S:	Weighting factors including and excluding toxicity	205
Table T	Impact categories and methods	206
Table U:	Chemical substance GaBi datasets that were analyzed for result variability across various countries	215
Table V:	Chemical substance GaBi datasets that were analyzed for the result variation across various technology routes	217

Abbreviations

AP	Acidification Potential
ADP	Abiotic Depletion Potential
B2B	Business-to-Business
B2C	Business-to-Customer
CHP	Combined Heat and Power Plant
DeNOx	NOx emission reduction
DeSOx	SOx emission reduction
DB	Database
DQIs	Data Quality Indicators
EF	Environmental Footprint
ELCD	European Reference Life Cycle Database
EoL	End-of-Life
EP	Eutrophication Potential
FAETP	Freshwater Aquatic Ecotoxicity Potential
GWP	Global Warming Potential
HTP	Human Toxicity Potential
IPCC	International Panel on Climate Change
ILCD	International Reference Life Cycle Data System
KEA	Cumulated Energy Approach (German: Kumulierter Energieaufwand)
LCA	Life Cycle Assessment
LCI	Life Cycle Inventory
LCIA	Life Cycle Impact Assessment
LUC	Land Use Change
MAETP	Marine Aquatic Ecotoxicity Potential
MSW	Municipal Solid Waste
NDA	Non-Disclosure Agreement
ODP	Ozone Depletion Potential
OEF	Organisation Environmental Footprint
PEF	Product Environmental Footprint
POCP	Photochemical Ozone Creation Potential
SCR	Selective catalytic reduction (DeNOx type)
SNCR	Selective non-catalytic reduction (DeNOx type)
TETP	Terrestrial Ecotoxicity Potential
WtE	Waste-to-Energy

1 Introduction and Aim of Document

Relevance, quality, consistency and continuity are the main aims of the GaBi Databases. The GaBi Databases are the result of over 500 person years of direct data collection and analysis and over 2,000 person years of accumulated project work by the Sphera domain experts. For the past 30 years, Sphera has constantly developed and advanced the GaBi Databases to better meet tomorrow's data needs today.

The goal of the GaBi Database & Modelling Principles document is to transparently document the boundary conditions, background, important aspects and details of the GaBi Life Cycle Inventory databases, as well as the basis of the models. This is intended to help data users to better understand the background and to better use the datasets in their own models. At the end of the document, you will find a brief description of the Life Cycle Impact Assessment (LCIA) methods included in the GaBi Databases. This document covers all GaBi Databases, which include the core GaBi Professional Database, the numerous GaBi Extension Databases, and GaBi Data-on-Demand datasets.

This document neither aims to answer every possible question nor to document every possible aspect, but to describe the most important principles that have been applied.

The GaBi Databases Modelling Principles aim to mirror our existing global, regional and local economy and industry supply chains. They reflect major international standards and relevant professional initiatives. While the GaBi Databases Modelling Principles are not used to test new methods, they are open for improvement as new methods or aspects have been sufficiently tested and proven to mirror the existing supply chains in an even more realistic way.

The GaBi Databases are an important source of background LCI data sources for multiple stakeholder groups: industry, academia and education, policy and regulation, research and development, and consultancy. Any of these stakeholders aiming for accurate and reliable result needs accurate and reliable data—without data, there is no result. Without quality data, there is a higher risk of inaccurate or misleading results. Note that scientific and educational goals are often different from those in policy making, development and industry. Expansion of knowledge may be the focus of one group, policy development the focus of another group, and innovation and critical decision making the focus of a third group. These different interests require different interpretations of the same underlying data of our common supply chains.

This underpins the GaBi Databases' overarching aim, namely, to represent the technical reality of our dynamic and innovative economies as adequately as possible at the given point in time. Achieving this goal and maintaining a high data quality requires technological, temporal, and geographical representativeness, professional data generation, and continuous database maintenance and governance, which are all important aspects of the daily work of Sphera's GaBi Data and Sector Expert Teams.



Professional database management is important to help ensure on-time delivery of databases in an annual upgrade cycle. It not only ensures the accuracy and relevance of results to help maintain a competitive advantage, it also protects clients from unwanted surprises resulting from longer upgrade cycles that would inevitably lead to substantial changes in results. The annual upgrade cycle therefore reduces uncertainty and mitigates the financial and reputational risks associated with using outdated data.

2 GaBi Database Framework

Successful, continuous and effective database provision needs...

- a professional database concept and management,
- consistent and central database development,
- database maintenance as well as frequent and efficient upgrade routines.

To enable a flexible use of the database content in different life cycle related applications and professional decision situations, the data should be suitable and adaptable to different schemes and standards of industrial and professional practice to the greatest extent possible while, most importantly and simultaneously, reflecting the real supply chain and technology situation. The GaBi Databases are hence developed, maintained and improved by well-educated and broadly experienced teams of different expert groups with broad and deep knowledge in their areas of expertise.

The methods and methodological choices used have been selected to reflect the supply networks in the most appropriate way to ensure that the method follows reality.

2.1 GaBi Database concept and management

Embedded into the operational framework of Sphera is the concept of a Master Database. The Master Database is one pillar of a three-pillar solution approach. The other pillars are engineering / consulting knowledge and professional software environment, respectively, as illustrated in Figure 2-1 below.

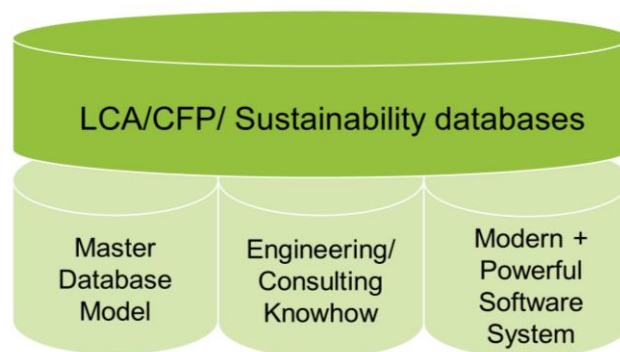

Figure 2-1: GaBi Database concept embedded in a three-pillar approach

Database development at Sphera involves experts on LCA methodology with technical expertise (see Chapter 2.6 for details on the different teams) and extensive knowledge of the relevant supply chain. Relevance checks and routine quality assurance checks are applied methodically. The generation of new data follows a standard procedure with a cascade of quality checks and is embedded into the GaBi Master DB concept.

Internal entry data quality checks: Newly generated data first passes a quality check by two LCA experts with engineering skills at Sphera in an internal review before entering the database environment.

Internal quality assessment of results: Depending on the type of data and its intended use, field of expertise and the sources providing the data (internal or external sources and/or organisations), our cooperation partners University of Stuttgart, Institute for Acoustics and Building Physics (IABP, former LBP), Dept. Life Cycle Engineering (GaBi) and Fraunhofer Institute for Building Physics IBP or independent organisations may provide a second round of quality checks, if necessary.

External quality assessment and review of 3rd party industry data: Data which is generated in conjunction with industry or trade associations for distribution with GaBi Databases to the professional LCA user community undergo an additional quality check by the respective data providers or by selected neutral third-party organisations as an independent third-party review.

External quality assessment of results: The dataset and systems provided with Sphera's GaBi software and databases for public use are constantly checked for technical plausibility by the users, as the results of the datasets are questioned in various external, professional and third party LCA study reports by industry, academia and policy bodies. Additional user feedback happens publicly via the online GaBi LinkedIn forum or directly from clients to individual contacts at Sphera. The information feedback is incorporated into the standard maintenance and update process of the databases, where necessary, and leads to consistently higher levels of quality and relevance over time. This process contributes to our continually improving data as knowledge and technologies progress or industrial process chains develop and change.

Additional external review activities: The different elements of the GaBi Databases were independently reviewed several times since 2012 by different organisations.

The ILCD compatibility of selected GaBi processes across all branches was reviewed for the European Commission's JRC by the Italian National Agency for new Technologies, Energy and Sustainable Economic Development (ENEA).

In the light of the Product and Organisational Environmental Footprint (PEF/OEF) Initiative of the EU Commission, the Spanish "Centro de Investigaciones Energéticas, Medioambientales y Tecnológicas (CIEMAT)" reviewed our data with focus on energy systems.

Both above reviews were commissioned by the European Commission.

Sphera delivered more than half of the official Environmental Footprint (EF) 2.0 databases to the European Commission from 2016 to 2017 and has so far delivered the commonly to be used core data on energy, transport, packaging and end-of-life (recycling, waste-to-energy, landfilling) for the EF 3.0 database. The datasets are derived from GaBi Databases with some

methodological adjustment in order to make the data fully EF conformant. All the EF datasets underwent an independent review, thereby also assuring the quality of the underlying GaBi models. This covers the energy, transport, packaging (non-plastic), plastics, End-of-Life (including recycling, energy-recovery, landfilling), minerals and metals, and the electrical and electronics sectors.

To complement external dataset reviews, Sphera introduced a technical and procedural review process that also included review of the GaBi Databases development process with the Germany-based international inspection and verification company DEKRA. As LCA continues to be used more broadly in industry, companies require increased accuracy, transparency and credibility of their data sources in order to make the best-informed decisions. Recognising this and in order to ensure consistency and quality of its GaBi Databases, Sphera finalized the first round of an “on-going technical review process with DEKRA”. The DEKRA review of the GaBi Database confirms that

- credible independent sources underpin each dataset,
- up-to-date engineering know-how is used in creating the dataset, and that
- accurate meta information are provided in the dataset documentation.

The review initially covered basic technologies, such as power plants, refineries and water treatment units underlying many other aggregated datasets and continues with datasets derived from these core models. In addition to the technical review of the datasets themselves, the quality assurance processes at Sphera are also subject to procedural review.

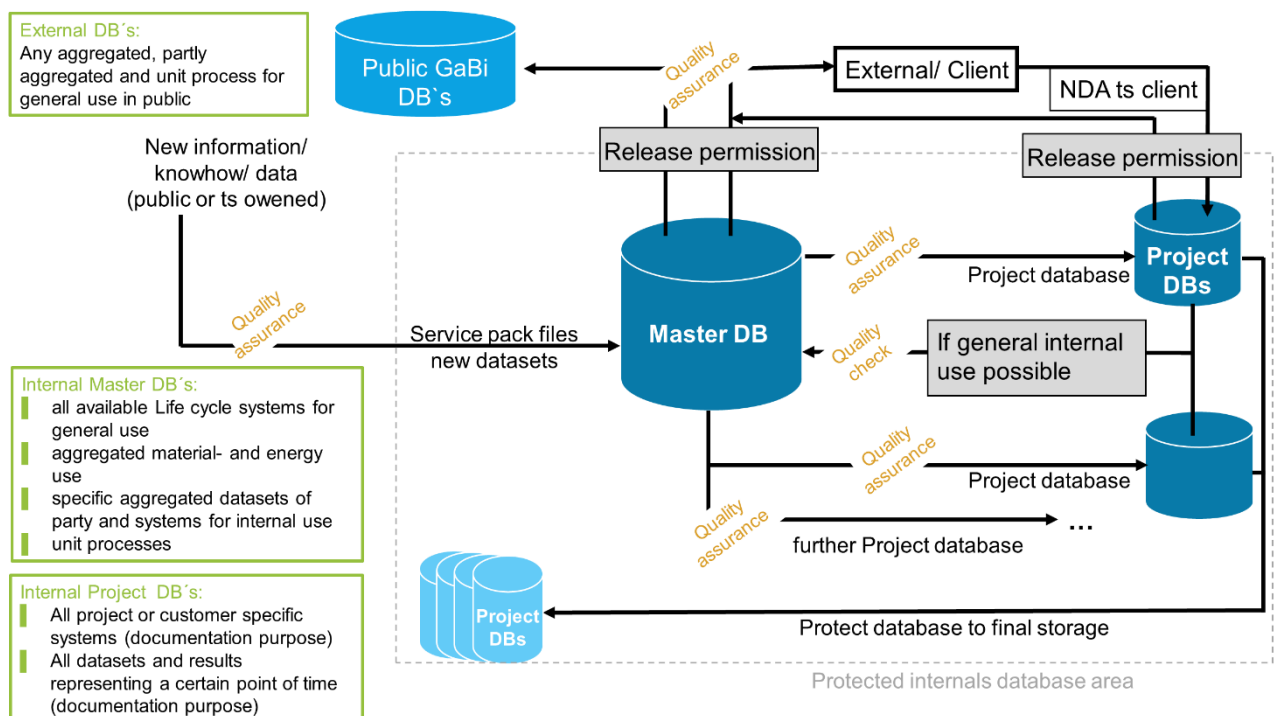

Figure 2-2: Database Management at Sphera

Quality assurance processes and review procedures are an integrated part of Sphera's Database Management, protecting confidential and sensitive project-related information of clients (data providers and data consumers) while enabling all users to benefit from the internal information, knowledge and expertise pool of Sphera.

Any confidential project or customer-related information is protected by a "Non-Disclosure Agreement (NDA)" and is kept securely separated from any publicly available database. Also within Sphera, the access to the Master database is restricted to individual members of the Data Team on a need-to-access basis, with a documented and countersigned access right, and with individual rights to read and edit.

2.2 GaBi Database development, maintenance and update

The development of LCA over the last 30 years continues to be industry driven. Naturally, the best LCI data for industry should be based on industry operations to ensure the proper representation of real production.

LCA databases began appearing in the early 1990s. GaBi was an early pioneer combining both database and software systems from the beginning, opening synergies and unique possibilities.

LCA Databases continue to grow in relevance. GaBi Databases evolved and established LCA in daily use early within both research and industry. Only professionally managed, maintained and updated databases continue to be highly relevant for industrial use.

Maintaining and updating databases is an important task, which is both a time- and management-intensive activity. Accuracy of data, new (practical and proven) methods and user requirements are just three examples requiring constant attention. And constant attention requires a consistent group of people taking care of specific topics and sectors:

- New scientific findings, new data and technologies, new methods all require constant database development.
- Clients base decisions for development of new products based on LCA, optimisation or investment all of which depend on reliable results, applicability and continuity in daily practise.

The GaBi Databases employ proven "best practice" data and approaches. New scientific methods and data are applied only after feasibility checks to reduce risks of wrong (product or process) decisions.

Sphera has an established management cycle concerning databases: Plan-Implement-Maintain-Review.



In **planning**, innovations and demand are core drivers of the activities. This may be new technologies, new regulations, new standards or new knowledge. Stakeholder feedback is collected wherever possible to ensure relevance and value.

In **implementation**, relevance and consistency are core drivers of the activities. This comprises LCI method and engineering knowledge combined to reflect the given economic and technical environment.

In **maintenance**, the frequency and temporal reliability of the delivery are core drivers to renew evolving data and retire outdated data. It is not the absolute age of the data that eventually leads data to become outdated but the relative age with regard to the innovation cycle of the sector.

In **review**, actual user feedback and check of supply chains are core drivers to map the data from the previous year against possible relevant changes of technology, economy or society in the current year.

The GaBi Databases approach is done “for practice with information from practice” and, as such, considers the critical success factors in professional LCA applications in industry. GaBi data is not any randomly available data but rather best practise information based on real world experience.

Access to raw data sources developed by Sphera and in-house engineering expertise enables the development and delivery within scope, on time, with high quality and guidance towards suitable data selection. A standard format for all LCI datasets is mandatory for all Sphera-owned data.

Sphera data is “industry-born” based on extensive stakeholder involvement and feedback from industry and third-party sources. Sphera welcomes constructive criticism as an important contribution to support continuous improvement.

Sphera models real supply chains for crosssectoral use for all B2B and B2C relationships. The data reflects specific and up-to-date technology and routes for individual sectors. Region-specific background systems are combined, wherever suitable and possible, with local/regional process technology information. Individual, user-specific modification, adaptation and extension on local situations with customer-owned data or parameterized data are possible. Individual data-on-demand can be created by Sphera with high levels of consistency and quality while ensuring data confidentiality is protected.

Regarding development, maintenance and update environments, a suitable group structure (see Chapter 2.6 for details) with different responsibilities at Sphera is in place. There is a direct relationship between software and database development, which supports practical and relevant solution pathways as many issues affect both fields.

Maintenance and support routines are installed, and updates are regularly conducted with the least possible user effort required, including smart database/software updates with automated addition of new standard LCI or LCIA data.

2.3 Structure of the Master Database contents

The Master Database is the core data repository and contains about 20,000 plan systems, each with one or more unit processes and several sub-systems. The GaBi Databases are hence by far the largest internally coherent and high quality LCI databases available.

In some cases, single cradle-to-gate systems involve several thousand individual plan systems and tens of thousands of individual processes tracing back to the resources in the ground.

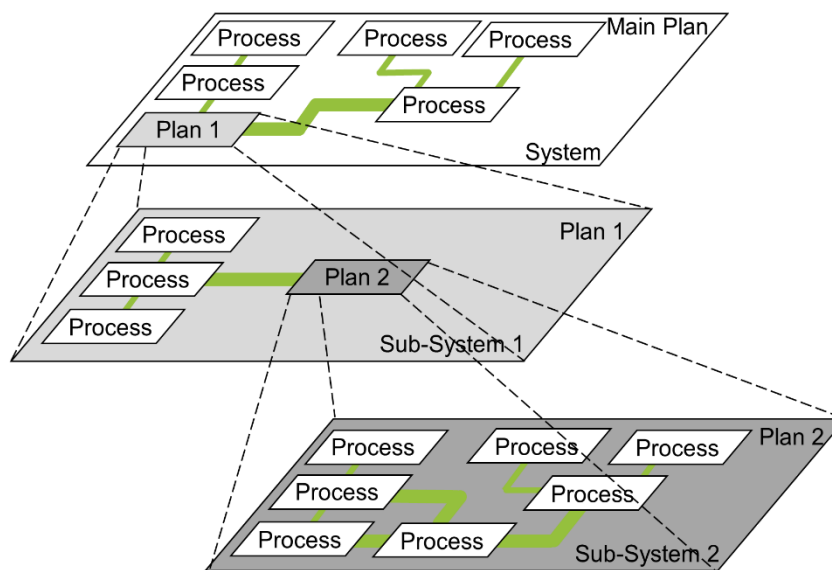

Figure 2-3: Hierarchical structure of the processes and plans

Each Sphera-owned, aggregated process provided in the public available databases has a corresponding plan system in the Master Database. Huge interconnected plan systems are the result, which would be hardly manageable without suitable LCA software support. In principle, it would be possible to display all sub-systems of all processes and plans of the complete Master DB. The resulting document would probably have about a quarter of a million pages¹ This is one main reason why GaBi and its corresponding Master database were developed: to be able to transparently and simply manage and use large process chain systems of real supply chains.

The graphical display for this document is therefore limited to relevant examples. It aims to transparently document the structural background of the Master Database. Further publicly available process chain and technology information on all datasets and systems is covered in the documentation.

¹Rough estimate assuming two screenshots per page.

We offer to share more details and process chain knowledge through bilateral business relationships. The publicly available databases contain plan systems, unit processes, partially aggregated processes and aggregated processes.

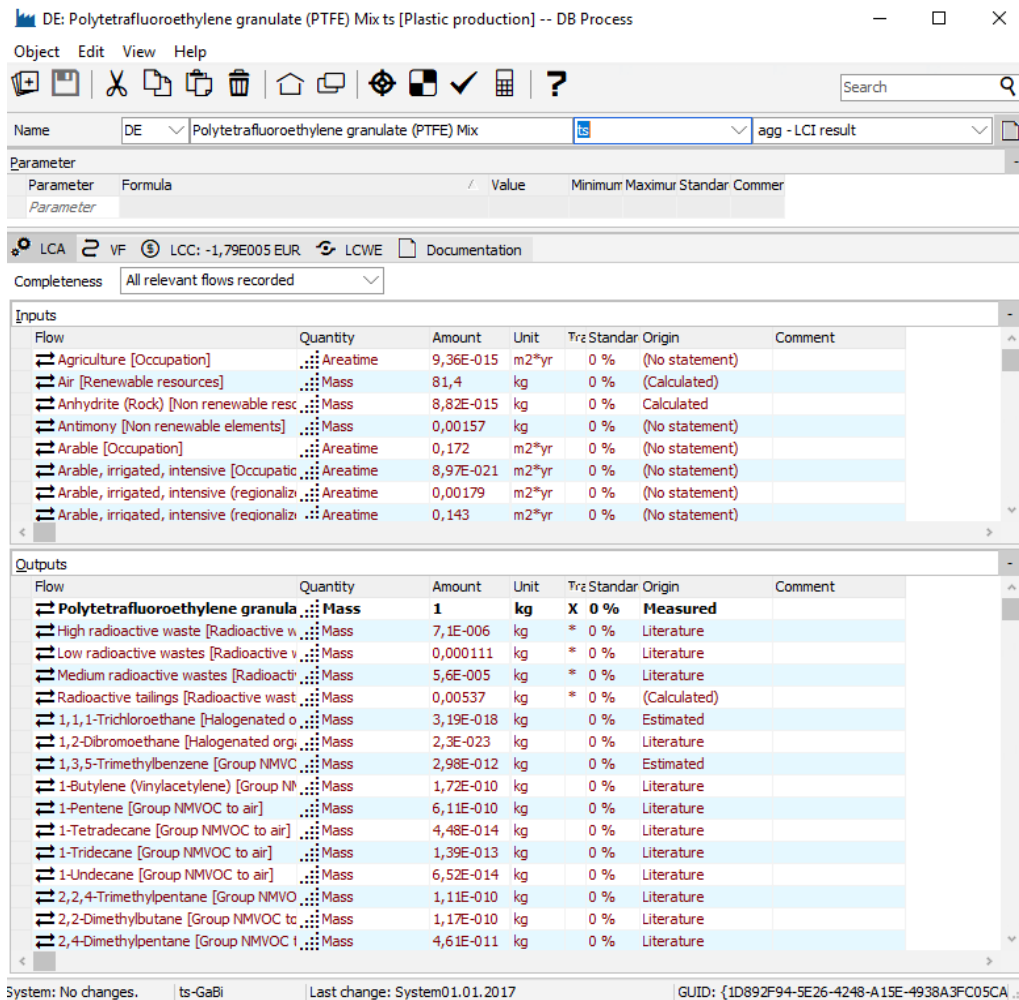

Figure 2-4: Aggregated dataset in GaBi, illustrative example

Aggregated processes are often the only way to provide relevant, suitable and up-to-date information of industrial sources to the LCA user community. Many users consider aggregated processes the best way to reliably and representatively model existing background systems.

In doing the modelling Sphera adds value from unit process data collection and compilation, through checking technically realistic mass and energy flows, to country-specific supply chain modelling.

Opening the first level of the related polytetrafluoroethylene production in the Master database shows the polymerization step with the respective unit process in the centre. Upstream sub-systems are shown on the left. Note that in the unit process, only intermediate flows are visualised; elementary flows such as resources or emissions are not visualised, but present in the individual unit processes (see Figure 2-5).

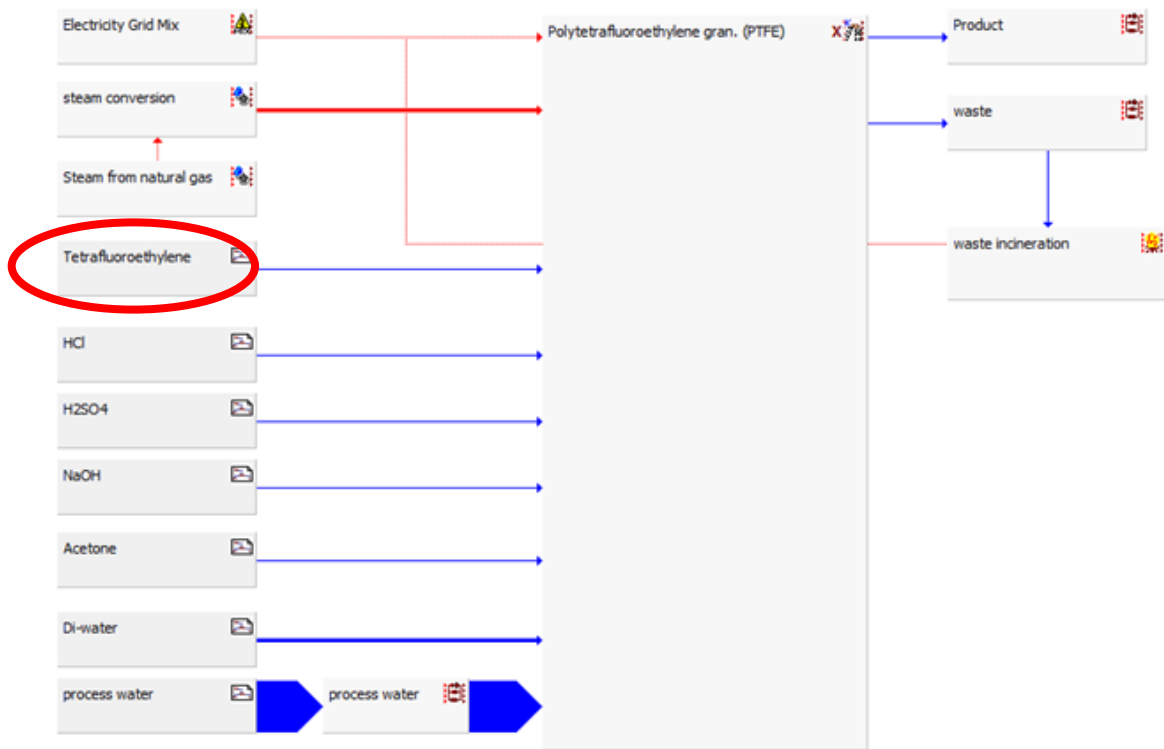

Figure 2-5: Polymerisation subsystem in GaBi Master DB

Figure 2-6 follows the single upstream pathway of tetrafluoroethylene indicated by the red circle in Figure 2-5...

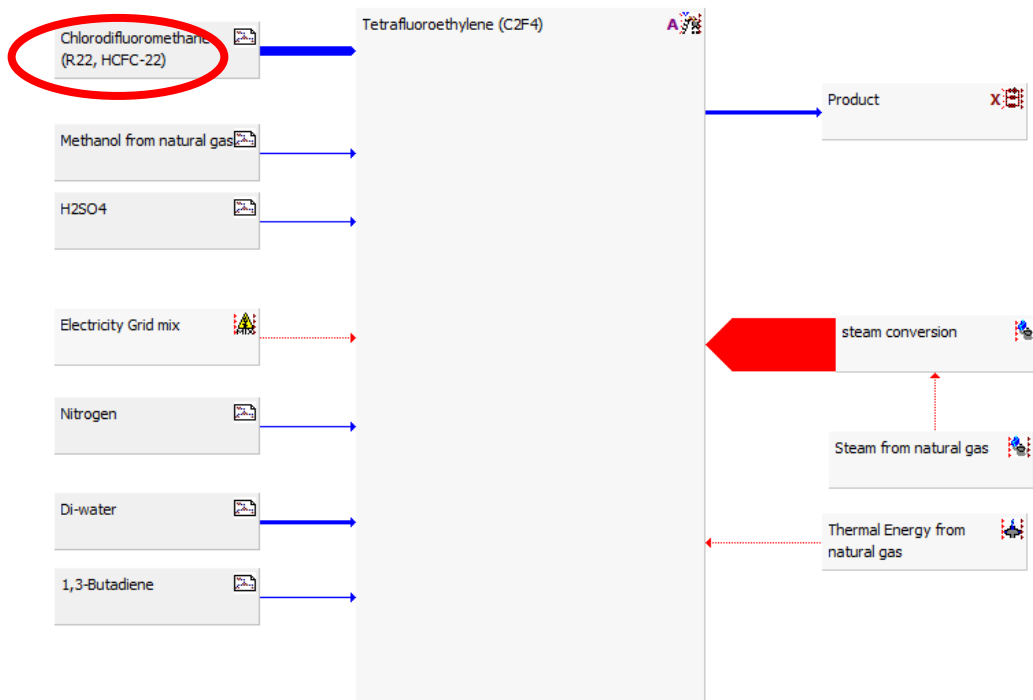

Figure 2-6: Tetrafluoroethylene subsystem in GaBi Master DB

...to R22 details in Figure 2-7 and on to chlorine mix details displayed in Figure 2-8...

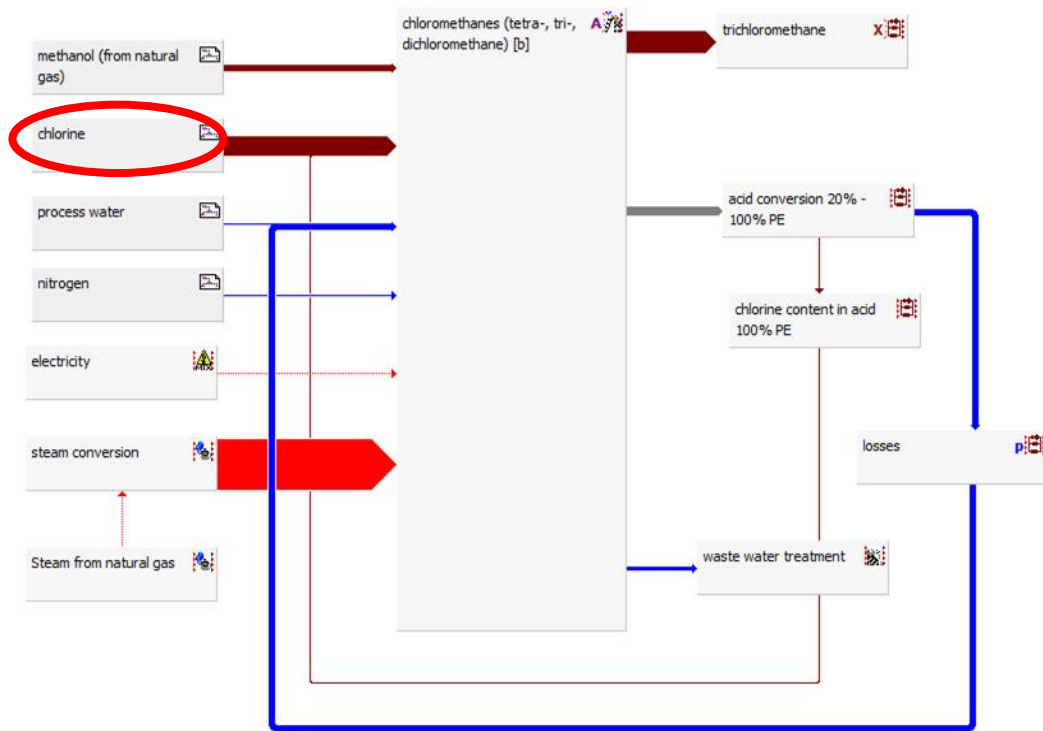

Figure 2-7: R22 subsystem in GaBi Master DB

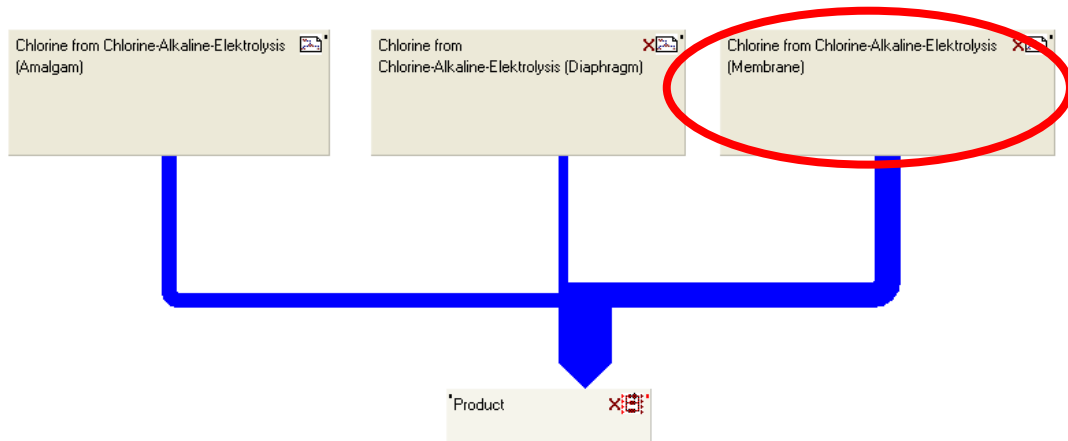

Figure 2-8: Chlorine production mix in GaBi Master DB

... which leads to the chlorine membrane technology details (Figure 2-9) and from there back to rock salt mining.

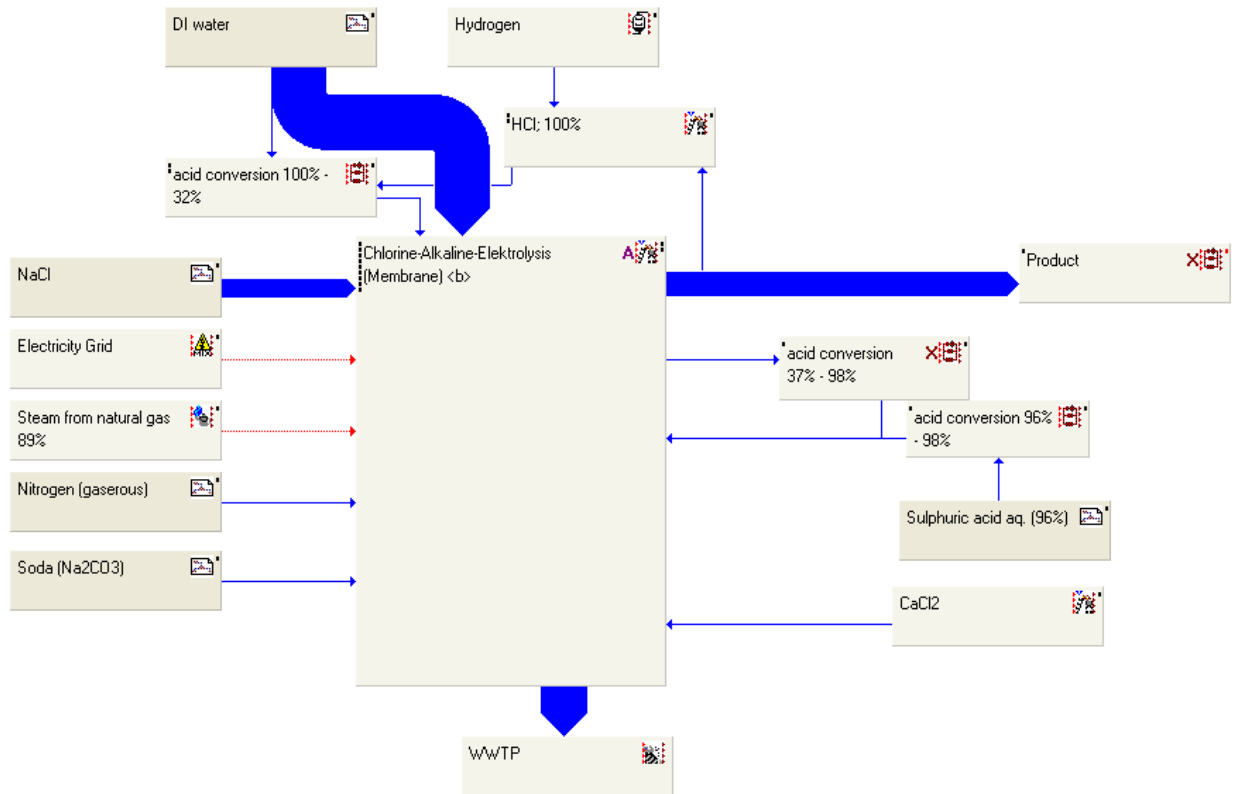

Figure 2-9: Chlorine membrane technology production in GaBi Master DB

The previous example showed the journey from polymer back to rock salt. The following example gives insight to the fossil fuel and organic process chain. Starting with the various refinery products diesel, gasoline, naphtha and gases on the right side of Figure 2-10...

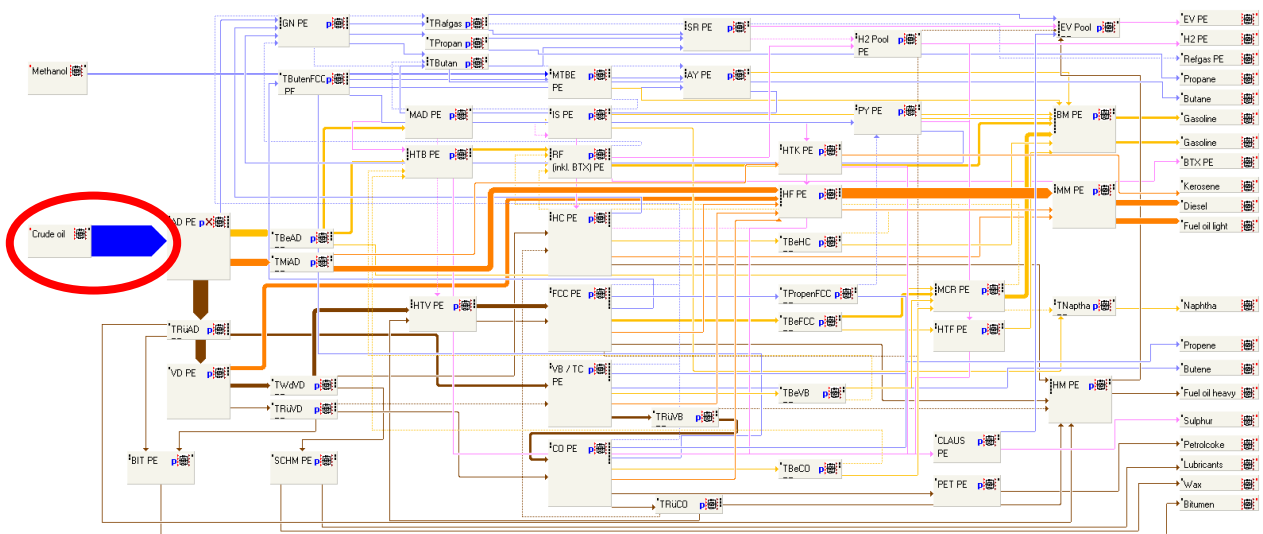

Figure 2-10: Refinery model in GaBi Master DB

... the refinery products can be traced back through the different refinery stages to the crude oil inputs on the left...

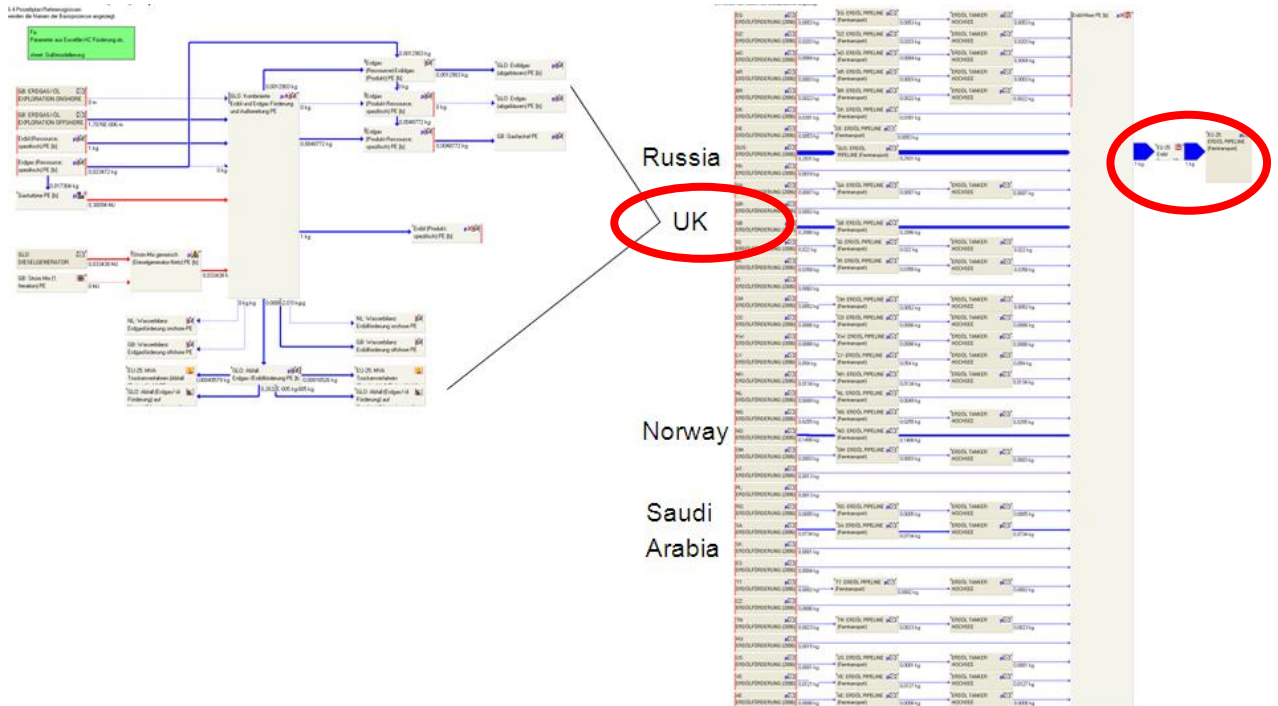

Figure 2-11: Crude oil import mix and country specific oil extraction in GaBi Master DB

...and from the crude oil import mix to the country-specific oil extraction and the bore holes at the source.

The next and last example shows the electricity model in the GaBi Master Database.

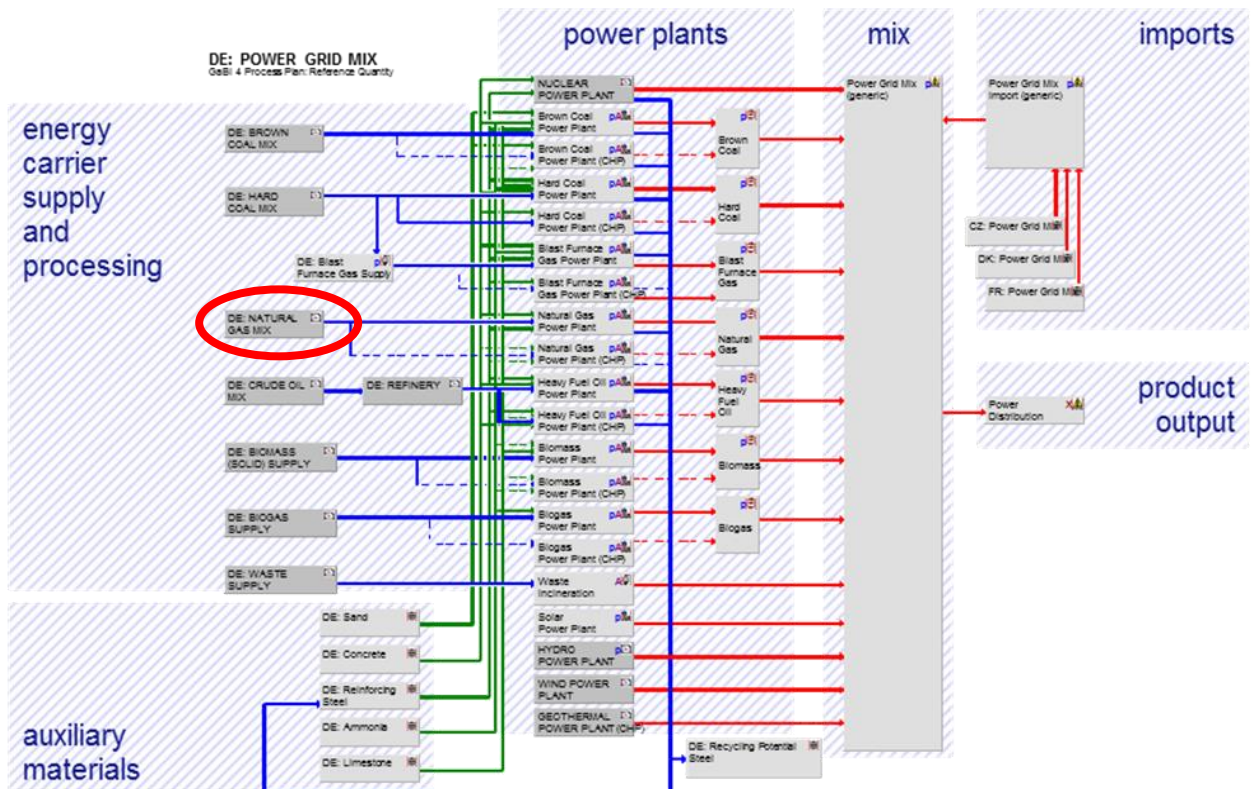

Figure 2-12: Example of a country-specific grid mix model in the GaBi Master DB

The product output on the right side of Figure 2-12 is 1 kWh of electricity at the consumer. On the left of the power plants, the country- or region-specific fuel mixes (hard coal, lignite, oil, natural gas) are shown...

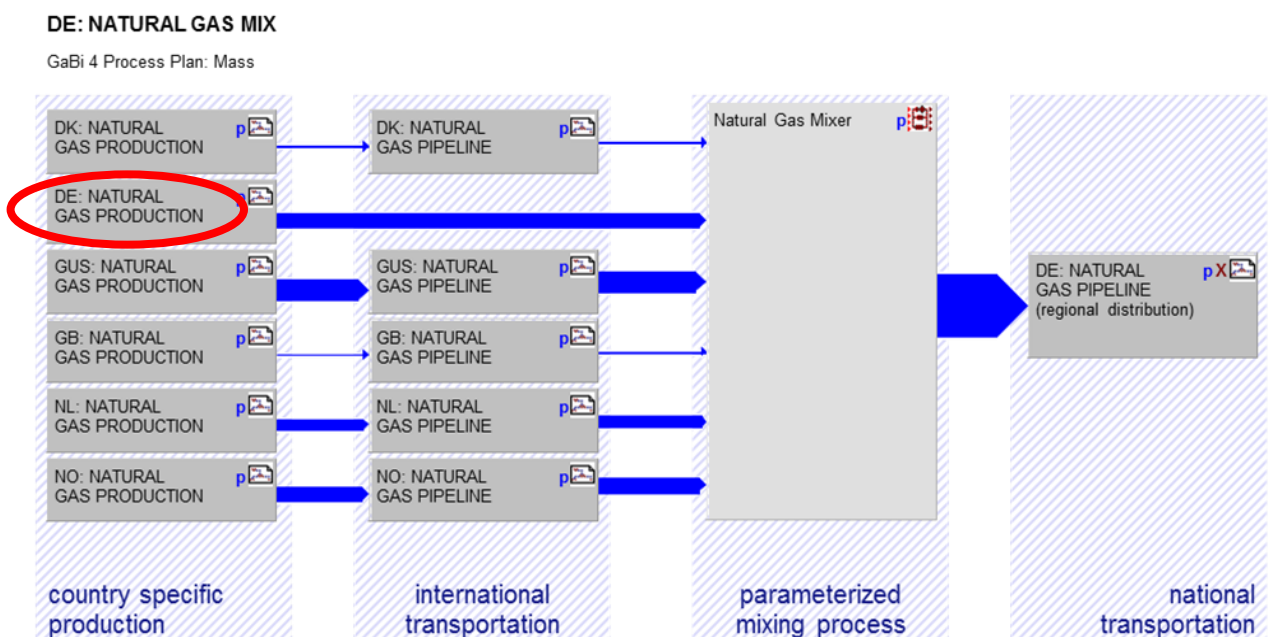

Figure 2-13: German natural gas consumption mix in GaBi MasterDB

...which are provided by the German consumption mix (incl. imports) of natural gas (Figure 2-13)

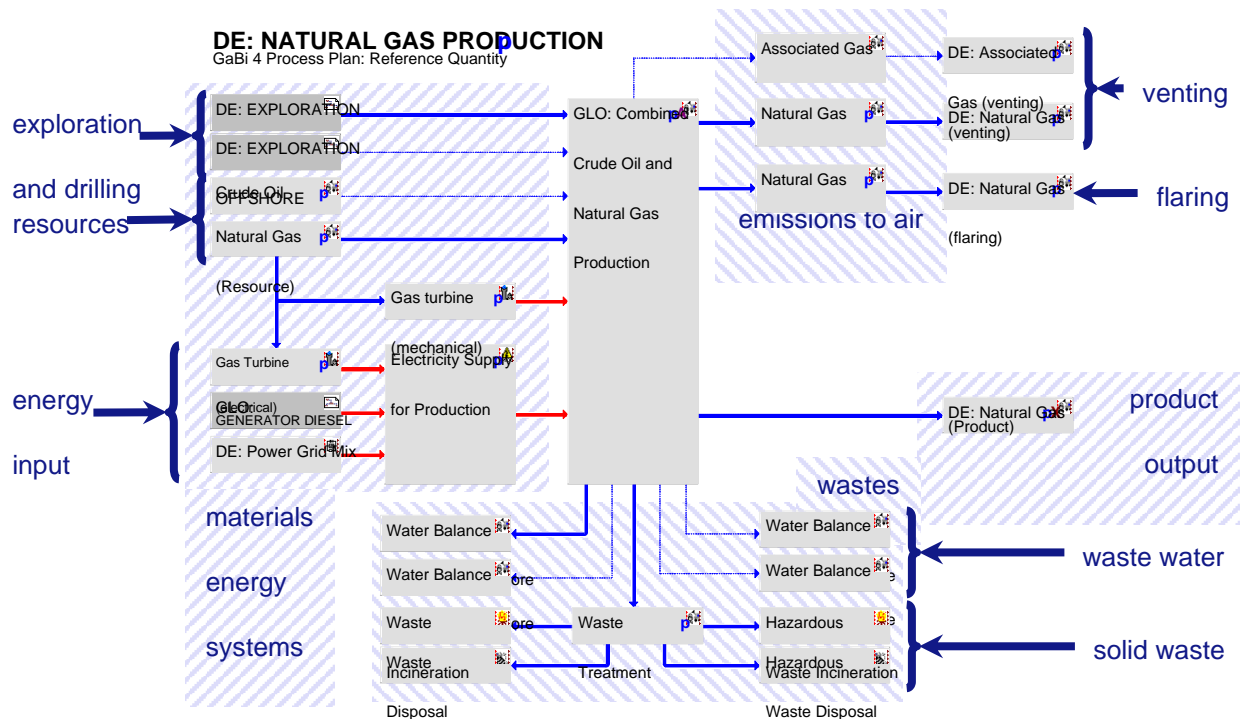

Figure 2-14: German natural gas production in GaBi MasterDB

...and can be traced all the way back to the natural gas production at the source (Figure 2-14).

Remember that the above screenshots represent only a very small amount of the total process chain network involved in the chosen PTFE example. **In summary, we can conclude that an aggregated dataset integrates a large amount of valuable information, which would otherwise be barely manageable.**

Thousands of aggregated, real world subsystems and engineering information are included and the underlying full models are updated regularly. Data collection time, industry research, compilation, and consistency checks create real B2B supply chains. Knowledge of technical aspects of supply chains has been documented, along with the over 500 person-years of work on the database and content.

2.4 Standardisation, conformance and application of LCI databases

The customer or case specific foreground model must be conformant to the desired approach. GaBi Software supports this objective in various ways with its flexible modelling features.

GaBi Databases are developed for use within different situations and applications as upstream, downstream and background data and seek to be in line with relevant existing standards, reference documents and best practise documents.

In this context, we primarily consider:

- LCA / LCI / LCIA: [ISO 14040: 2009, ISO 14044: 2006]

- Environmental labels Type I [ISO 14020: 2000], Type II [ISO 14021: 1999], Type III [ISO 14025: 2006], Environmental product declarations (EPD) [ISO 21930: 2007], Sustainability Of Construction Works - Environmental Product Declarations - Core Rules For The Product Category Of Construction Products [EN 15804+A1 2014] and [EN 15804 2019], Institute Construction and Environment [IBU 2011], Fiches de Déclaration Environnementales et Sanitaires (FDES) [NF P 01 010: 2004]
- Greenhouse Gases / Carbon Footprint: [ISO 14064-1: 2006], [ISO/TS 14067], WRI GHG Protocol Corporate Value Chain (Scope 3) [GHGPPc 2011] and Product Life Cycle [GHGPP 2011], [PAS 2050: 2011]
- Carbon Disclosure Project (CDP)
- Environmental Management ISO 14001, EMAS II, EMAS III
- Database reference systems and guidelines: Product Environmental Footprint (PEF) and Organisation Environmental Footprint (OEF) [PEF GUIDE 2013] and [PEF METHOD 2019], Product Environmental Footprint Category Rules (PEFCR) guidance 6.3 [PEFCR guidance 2017], ILCD reference data system documents and format [ILCD 2010], SETAC/UNEP Global Guidance on databases [UNEP/SETAC 2011], Eco-profiles and Environmental Declarations, various method guidelines by international industry associations
- CDP Water Disclosure and Water Footprint Network Manual

Because LCA is a multi-function/multi-application method, the GaBi data is generally developed to be used consistently within the aforementioned frameworks (please visit also <http://www.gabi-software.com/international/solutions/> for further details). It might be possible that some frameworks define in certain specific applications contrary requirements that one background dataset cannot match both by default. Therefore, the GaBi system supports and allows for specific addition/modification/adaptation of the dataset, if needed. Depending on the necessary changes, this may have to be done by and at Sphera, to contain and protect confidential industry information in the background: Having access to recent and industry-based LCI datasets cannot be combined with having full access as final user to the underlying life cycle model.

2.5 Databases in reference networks, standards and principles

GaBi Databases are renowned for their practical relevance and frequently used to support different initiatives, industry or national databases schemes. Conversely, initiatives, industry or national databases schemes influence the GaBi Databases. This symbiotic relationship enables practicability, applicability, compatibility and distribution of data within relevant professional frameworks. The following graph illustrates the dependencies within this coexisting symbiosis.

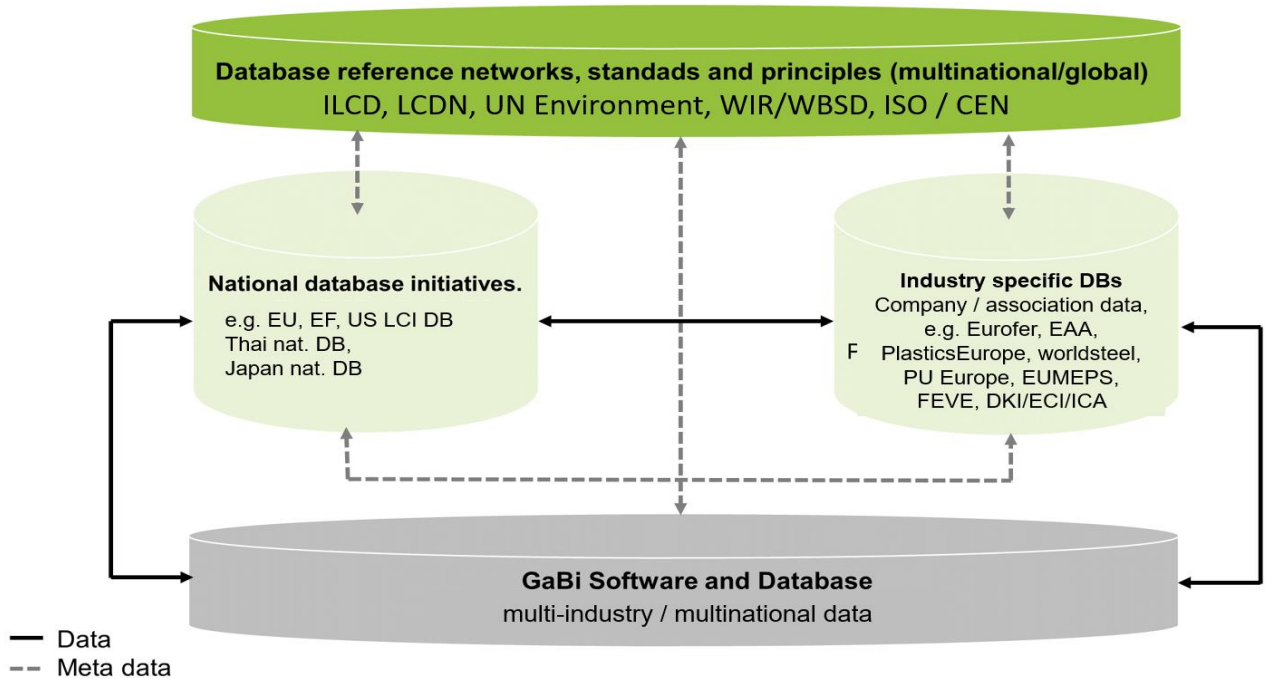

Figure 2-15: GaBi DB in the international context of databases and frameworks

Potential data and metadata flows are visualized between the different professional frameworks. Sphera data influences standards and standards influence Sphera data. Sphera data aims to be applicable in as many relevant standards as possible.

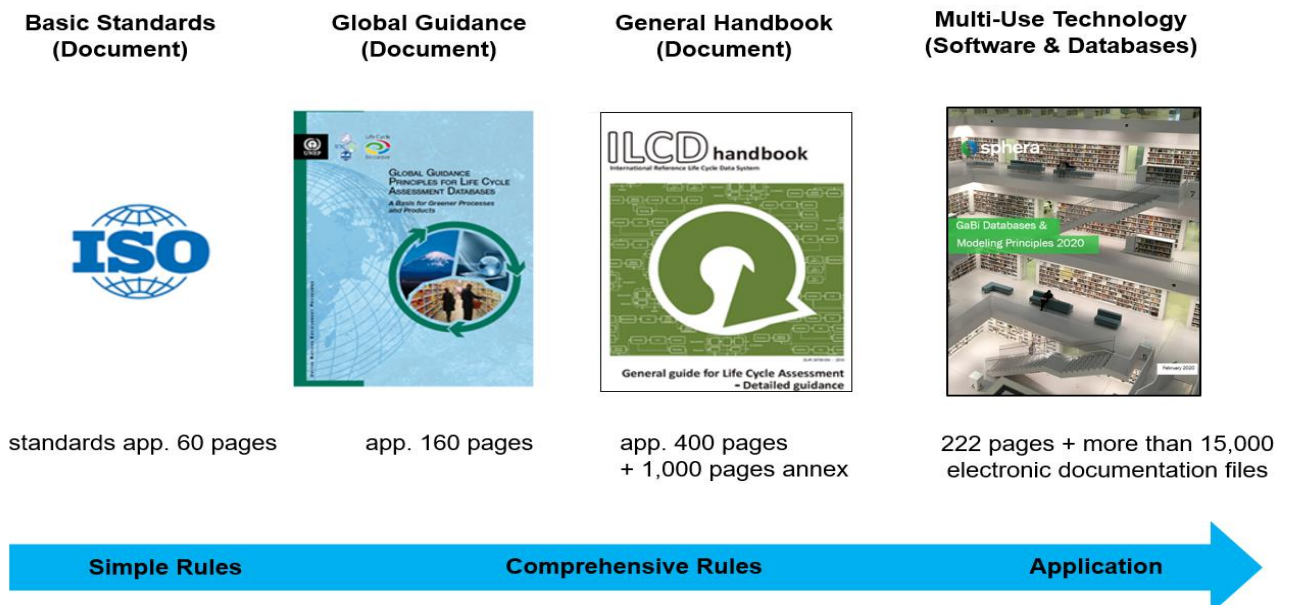

Figure 2-16: Turning standards into technology solutions

This calls for continuous adaption due to stakeholder feedback and the related implementation time needed to improve and evolve data and standards.

Sphera databases turn theory into professional practice. Standards, guides and handbooks are an important basis of our supporting work.

Turning paper (i.e, standards) into technology solutions is a core deliverable of Sphera databases. This provides access to standardized information to a wide range of stakeholders in a form they can use in day-to-day operations and improved upon through the continuous feedback loop outlined previously.

2.6 GaBi LCI Teams

GaBi Databases are the result of teamwork from around 10 industry sector expert teams and one core GaBi Data team of 10+ data content experts that facilitate the process, ensuring the quality and governance procedures are adhered to. Each expert team is responsible for modelling its specific system, as well as documenting the generated LCI. Each team requires experts that have a broad and deep expertise in the following fields:

- Technical knowledge specific to the given industry sector
- Performing LCAs and specifically having experience in analyzing technical production routes
- Good understanding of the analyzed production technologies applied to material production and/or power generation
- Sensitivity to the industry's current state having an appropriate understanding of the role of LCA within industry
- Self-directed work in effective cooperation with industry

The coordination of all expert teams contributions is the task of the core GaBi Data team. It provides the technical platform and methodological guidelines to all expert teams to ensure a consistent and synchronized database management. It also serves as an interface to clients, the market and the scientific community to receive feedback on existing database content, to make sure the GaBi Databases are in line with the development of methodologies, the demands of the market, and to constantly improve the internally used workflow and guidelines. In this way, consistency throughout all GaBi Databases can be assured.

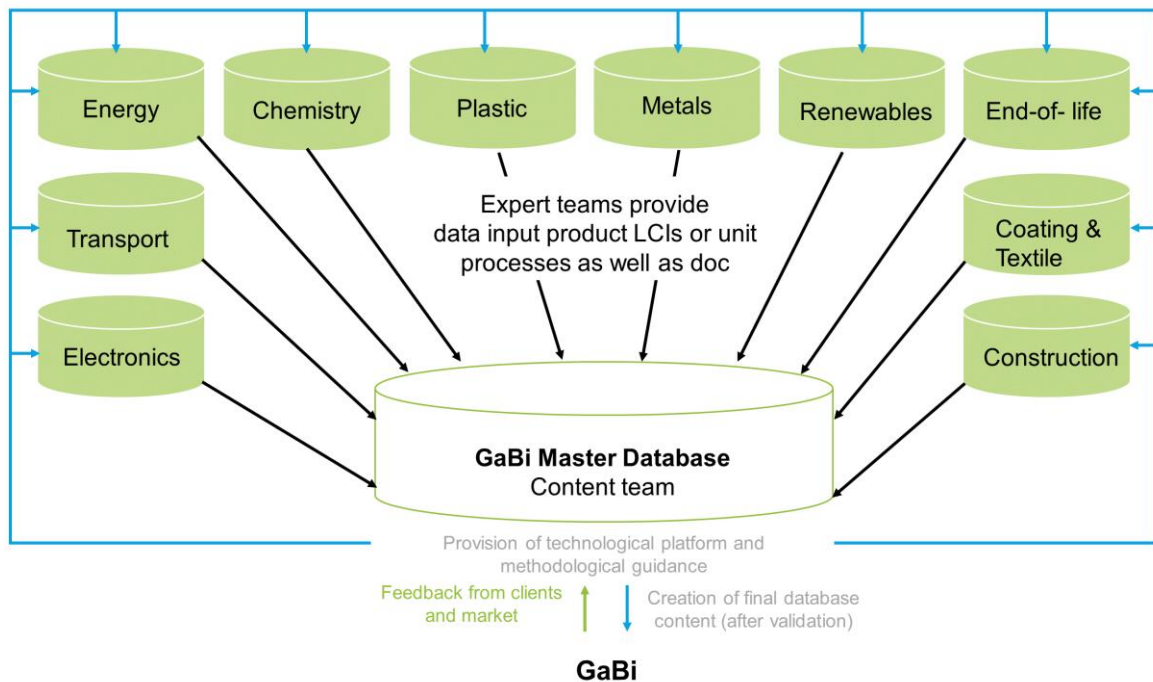

Figure 2-17: GaBi LCI industry sector Expert Teams and the core GaBi Data “Content” team

The Sphera-owned full LCI systems, including unit processes, plan systems and aggregated data, is the core of all GaBi Databases. However, as we aim to host and provide all relevant data sources consistently; Sphera is open for anybody that would like to publish technically sound and consistent data of any kind. This could be unit processes, plan systems or aggregated data.

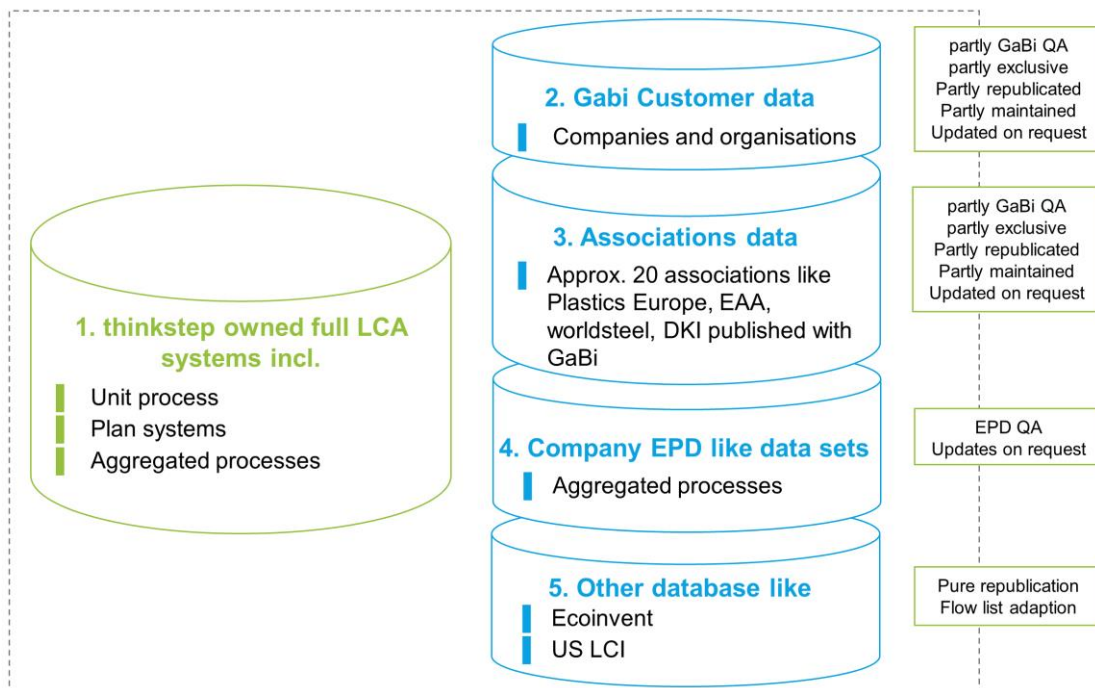

Figure 2-18: Overview of relevant data sources consistently covered in GaBi Databases

3 Methodological Framework

This chapter summarises important methodological principles, which are applied in GaBi database modelling and are utilised if new datasets are developed or existing datasets are updated.

3.1 Definition of tasks in database work

Database work can be separated into the following categories:

- a) Database development
- b) Database maintenance

In Data and Database development, new LCI data and databases are created using best-available raw data sources and appropriate methodological approaches to set-up new data the first time as consistent to existing data as possible.

Data and Database maintenance keeps existing LCI data and databases constantly up-to-date in terms of relevant and practically proven changes to data formats, flow formats, flow hierarchies and new methodological findings. Data and Database maintenance further involves frequent upgrades on new technological background information of unit processes, upstream technology information and technology routes, consumption and production mix figures for commodities, new impact factors, as well as new combined software-database functions that enable the use of generic data in a broader, more flexible and extended way.

For any of the above-mentioned tasks in database work we use the phrase “modelling”.

These modelling processes contain the following main steps:

- Goal and scope
- Data collection/check and system modelling
- Data quality requirements and checks
- Documentation and publication

The “GaBi Database and Modelling Principles” are the basis for consistent database work. These guidelines address the important points but are not exhaustive. Transferring theory into practise requires interpretation and experience and, as a result, the data users are responsible for selecting the appropriate background data and modelling principles for their specific application.

3.2 Goal

The results of an LCA study, as a rule, are related to a specific question. Therefore, the goal definition of an LCA study is of vital importance. The same applies to the development of generic and representative (single) datasets.

The main goal of all datasets in GaBi is to reflect the reality of our industrial and business networks and to provide a maximum degree of goal and scope freedom to the user. Consistency is important in that all sources used fit to this industrial reality and our engineering knowledge.

Concerning the ISO 14044 standard [ISO 14044: 2006], the goal of GaBi data can be understood as follows:

- Intended application: All practical life cycle-related applications that aim to maintain links towards or are based upon the ISO 14040/44 series.
- Reasons: You cannot manage what you cannot measure, and as such, LCI data is the basis for supporting the overall objective of sustainable development in the environmental dimension. Reasons to be specified within context of the system under investigation.
- Intended audience: All LCA practitioners in industry, research, consulting, academia and politics that aim to base their individual work on accurate and reliable data.
- Comparative assertions: No comparative claims are intended or supported on solely an inventory level from the database level. The databases are a consistent compilation of different datasets per functional unit, but direct comparison on the database level is not appropriate because proper (use case specific) modelling based on a functional unit is needed to ensure fair comparisons. The user is, however, able to take data and set up comparative assertions disclosed to public, which are its own responsibility.

3.3 Scope

The scope of the dataset and data systems depend on the type of dataset requested (see Gate-to-Gate, Cradle to Gate and Cradle to Grave²).

In most cases, the complexity of the answer or result interpretation is strongly dependent on the degree of desired general validity of the answer or result interpretation.

2 To avoid confusion by using any “en vogue terms” of non-standardised concepts and visions, the well-known and established term “Cradle to Grave” is used. The broadly used “Cradle to Grave” approach is able to include all kinds of End-of-Life and recycling options. So the “Cradle to Grave” approach is used to model all kinds of cycles and recycling issues and is not used in contrast to any other method, as all aspects of technical and natural cycles, e.g., carbon, water and nutrients, can be covered.

Models of specific circumstances tend to be described with less complex systems, fewer possible varying circumstances or sensitivities that must be addressed. However the data for these specific circumstances need to be known.

Models of general circumstances tend to be described with more complex systems because more possible varying circumstances or sensitivities must be addressed. Circumstances that are more general enable the use of more generic data.

In other words: for specific results or a specific company product, specific foreground primary data from the related company is needed. For general results concerning an average product, generic background data can be suitable.

To avoid misinterpretation due to the use of data and datasets, the type of data and its boundaries, the specific product systems and its upstream technology routes must be documented and understood. The GaBi datasets and the related documentation provide the necessary information to avoid misinterpretation.

3.3.1 Function and Functional Unit

The functional unit is a “quantified performance of a product system for use as a reference unit” in a life cycle assessment study [ISO 14044: 2006]. As such, a proper functional unit allows for the fair comparison of product systems providing a common function.

Given the Cradle to Gate character of most datasets and plan systems in the GaBi database, the functional unit is always defined as providing a certain unit of product output. Depending on the product, the functional units used in the GaBi Databases [GABI] are essentially physical metric [SI]-units related to the amount of product, e.g., 1 kg, 1 MJ, 1 m³. The functional unit of each process is defined within the process³.

3.3.2 Definition of terms within system boundaries

The system boundary defines what is included in the dataset: a ‘single operation’ or ‘gate to gate’ unit process, a ‘cradle to gate’ aggregated dataset or a ‘cradle to grave’ aggregated dataset.

³Note that cradle-to-gate comparisons based on these basic SI units are usually not able to support comparative assertions between products as these require the functional unit to be defined based on the function of end use products (e.g., a consumer good, a building, a vehicle) rather than intermediate goods like the ones that the GaBi Databases provide the background data for. In addition, such comparisons need to take into account the full life cycle unless use and End-of-Life do not significantly affect the conclusions..

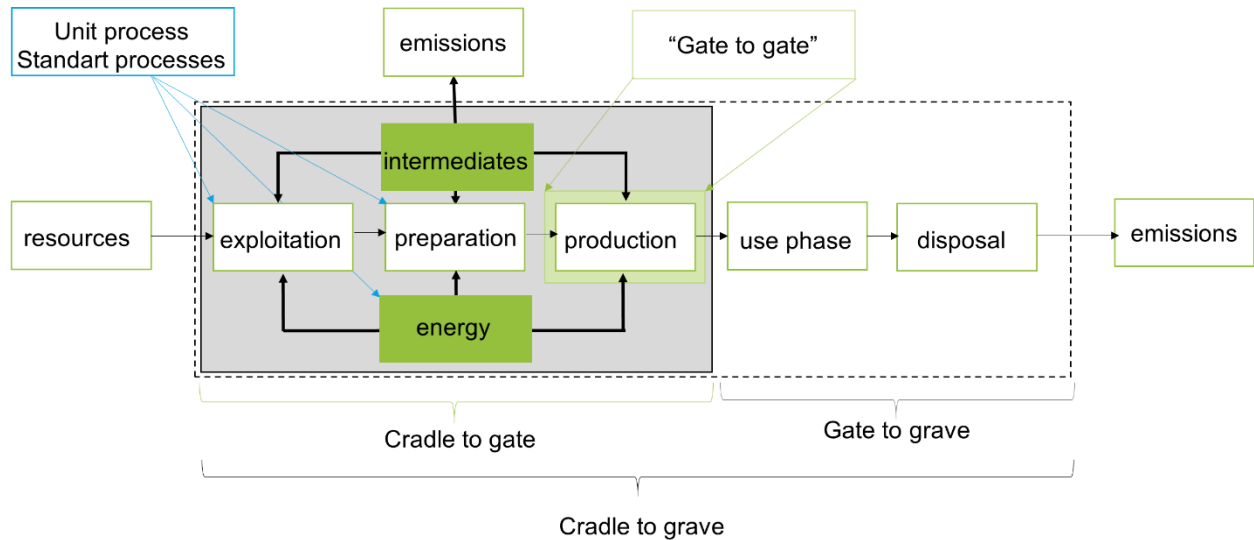

Figure 3-1: Graphic representation of different (sub-) system boundaries

Figure 3-1 is a representation of the system boundary definitions.

- **Single operation unit process:** A technically not further separable process step, or several processes that are joined in a e.g. machine that produces one or more products via joint processing.
- **'Gate to Gate' black box unit process:** All company or site-related activities from material acquisition or procurement, beginning at entrance gate through all the production steps on site, until final commissioning steps before leaving the site gates again.
- **'Cradle to Gate' LCI result (aggregated) dataset:** All activities from resource mining through all energy and precursor production steps and on site production, until final commissioning steps before leaving the site gates.
- **'Cradle to Grave' LCI result (aggregated) dataset:** Cradle-to-Gate extended through the use, maintenance and the end of life (disposal, recycling, and reuse) of a product.

During development of a dataset, the system boundaries can be subjected to step-by-step adjustments due to the iterative nature of data system set up and validation procedures.

Figure 3-2 gives an example of an example product system. Elementary flows enter and leave the system environment, as do product flows to and from other systems. Included within the system environment are different transports, energy supply, raw material acquisition, production, use, recycling/reuse, and waste treatment, depending on system boundaries. The respective system boundaries are defined by the type of dataset.

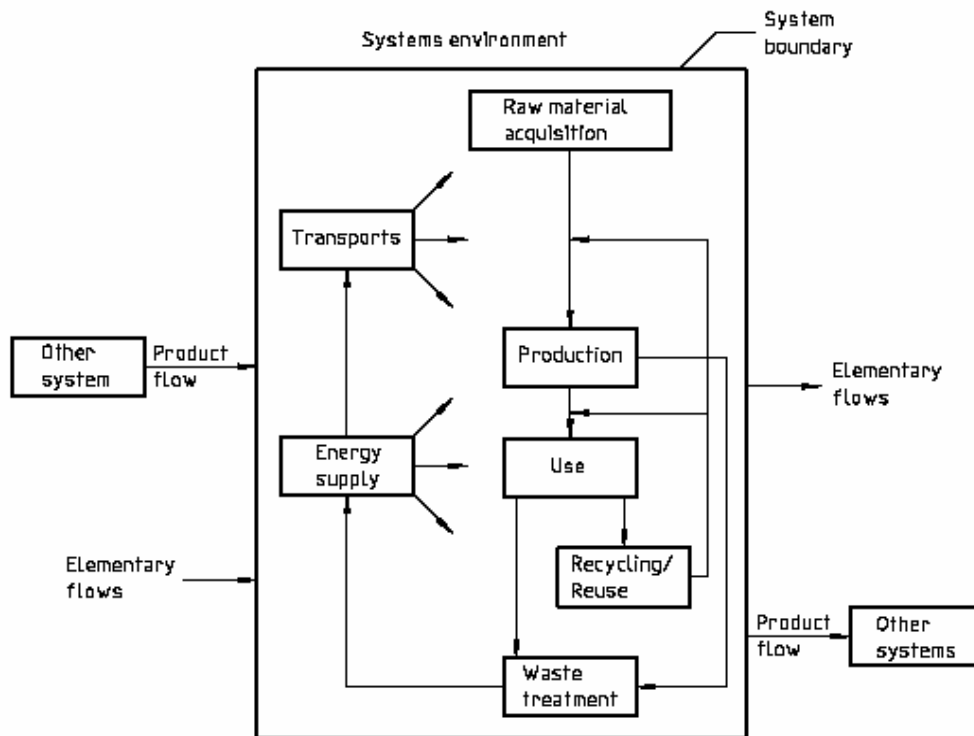

Figure 3-2: Generic example product system of a dataset development standard [ISO 14040: 2006],

3.3.3 System boundaries for the creation of standard LCI cradle to gate datasets

Within this section, the system boundaries for the generation of standard life cycle inventories are described. System boundaries are defined by the included and excluded processes of the foreground and background systems.

The foreground system boundaries are described in the documentation of the GaBi dataset (<http://www.gabi-software.com/international/databases/>).

The background system boundaries of the GaBi datasets are described in the following tables. The models are configured using hundreds of parameters in the software, which would be difficult to list here. In the following tables, the system boundaries of the main operations in the background system of GaBi dataset are documented.

Table A: Background system boundaries

	within system boundary ⁴	outside system
Crude oils and natural gases	primary, secondary and tertiary production per country	offshore supply vessels, onshore drilling transports and some minor drilling chemicals
	onshore processes of exploration and drilling per country	
	offshore processes of exploration and drilling per country	
	resource extraction	

⁴If relevant in the context of the country- or technology specific data system.

	venting and flaring emissions	
	drilling meter length	
	generators (diesel/gasoline) and electricity	
	thermal and mechanical energy	
	water use and wastewater treatment	
	waste and hazardous waste treatment	
	share of spilled crude oil from well testing	
	share of vented natural gas from well testing	
	bentonite and barium sulphate use	
	infrastructure	
	see also http://www.gabi-software.com/international/databases/	
Coals and Lignites	open pit operations per country	production of conveyers and mining vehicles
	under ground operations per country	
	soil removal and digging	
	overburden	
	mining trucks and excavators	
	conveyors	
	water pumping	
	water use and wastewater treatment	
	air conditioning	
	explosives	
	dust and explosion emissions	
	specific pit methane, CO2, chloride	
	fuels and electricity	

Table A Background system boundaries (continued)

	within system boundary ⁵	outside system
Power plants (electricity/heat)	all relevant combustion and off gas cleaning steps (see screenshot in Chapter 2.3) per country	construction processes of power plant
	power plant park per country	
	fuel characteristics per country	
	imports of other countries	
	all relevant emission country and technology specific	
	DeNOx and DeSOx units	
	electricity/heat shares	
	distribution losses	
	off gas treatment chemicals	
	infrastructure	
	see also http://www.gabi-software.com/international/databases/	
Refinery operations	all relevant refining steps, approx. 30 different (see screenshot in Chapter 2.3) per country	Construction and infrastructure
	crude oil characteristics per country	
	H2 production in reformer and use	
	external H2	
	process water	
	all relevant refining emissions per country	
	desulphurisation and treatment	
	internal energy management	
	methanol, bio-methanol	
	product spectrum of 21 products per country	
	see also http://www.gabi-software.com/international/databases/	

⁵If relevant in the context of the country- or technology specific data system.

Table A Background system boundaries (continued)

	within system boundary ⁴	outside system
Mining ores and minerals	ores concentrations and combined ore shares per country	production of conveyers and mining vehicles
	open pit operations	
	under ground operations	
	soil removal and digging	
	landfill overburden	
	mining trucks and excavators	
	conveyors	
	water pumping	
	water use and treatment	
	air conditioning	
	explosives	
	dust and explosion emissions	
	thermal energy propane	
fuels and electricity		
Ore beneficiation	process chemicals	infrastructure and machinery
	fuels and electricity	
	thermal energy	
	process water	
	wastewater treatment	
	ammonium sulphate use	
	waste and tailings treatment	
	end of pipe measures and emissions	
Metal smelter, electrolysis and refining	electricity specific per electrolysis	infrastructure and materials of facilities
	silica use, oxygen use	
	compressed air	
	coke and related reduction media	
	waste and slag treatment	
	hazardous waste treatment	
	auxiliary chemicals, caustics, chlorine, HCl, formic acid, soda, ammonia	
	thermal energy LPG, naphtha use	
	water use and wastewater treatment	
	see also http://www.gabi-software.com/international/databases/	

Table A Background system boundaries (continued)

	within system boundary ⁴	outside system
Chemical Synthesis, Formulations and Polymerisations	all relevant educts or monomers	some catalysts of confidential or patented composition and materials of reactors and facilities
	electricity specific per reaction type	
	thermal energy use or production	
	waste treatment	
	hazardous waste treatment	
	auxiliary chemicals	
	water use and wastewater treatment	
	purge purification of recycling (if any)	
	see also http://www.gabi-software.com/international/databases/	
Mineral processing and kiln processes	all relevant mineral inputs and fuels	infrastructure and materials of machinery
	electricity specific per kiln and operation type	
	thermal energy	
	waste and hazardous waste treatment	
	end-of-pipe operations	
	auxiliary chemicals	
	water use and wastewater treatment	
	particle and combustion emissions	
	see also http://www.gabi-software.com/international/databases/	
Agrarian products and renewables	CO ₂ uptake, sun light and nitrogen balance	farm infrastructure and materials of machinery
	rain water, irrigation water, water pumping	
	individual pesticides per crop	
	individual fertilizers per crop	
	land use and reference systems	
	fertilizing effects of crop residues and intercrops	
	tillage and all related soil preparation	
	tractor and all related machinery	
	transports to field / farm	
	electricity and fuels for cultivation	
	electricity and fuels for harvesting	
	see also http://www.gabi-software.com/international/databases/	

Table A: background system boundaries (continued)

	within system boundary ⁴	outside system
Electronic products and components	NF-metal and precious metal materials	infrastructure and materials of machinery
	polymer and resin components	
	Solders	
	housing and frames	
	fire retardant	
	printed wiring boards	
	processing and assembly	
	Etching and processing chemicals	
	see also http://www.gabi-software.com/international/databases/	
Water supply	water withdrawal and pumping	infrastructure and materials of machinery
	mechanical and chemical (pre-) treatment	
	chemicals for processing (ClO ₂ , O ₃ , ...)	
	electricity and thermal energy technology specific	
	reverse-osmosis and membrane technology	
	see also http://www.gabi-software.com/international/databases/	
EoL water treatment	mechanical and chemical (pre-) treatment	materials of machinery
	chemicals for processing (ClO ₂ , O ₃ , ...)	
	sludge and slag treatment (fertilizer or incineration)	
	infrastructure	
	see also http://www.gabi-software.com/international/databases/	
EoL landfill	Leachate treatment (incl. chemicals and sludge drying)	materials of machinery
	Landfill gas processing	
	infrastructure	
	see also http://www.gabi-software.com/international/databases/	
EoL incineration	waste input specific (composition, calorific value)	materials of machinery
	fuels, co-firing, combustion, boiler, SNCR/SCR	
	active filter, end-of-pipe, DeSO _x	
	chemicals, water	
	Efficiency and energy recovery (electricity/heat)	
	Combustion calculation incl. all relevant emissions	
	infrastructure	

	see also http://www.gabi-software.com/international/databases/	
--	--	--

All datasets of commodities and products are modelled within the foreground system boundaries described in the documentation and within the background system boundaries described above.

For any of the Sphera-owned datasets, the underlying plan systems are accessible in the Master Database and Sphera can grant access rights (e.g., for review purposes) under bilateral agreements and NDAs. Sphera Master Database content is valuable, privately financed information, developed, collected and compiled with a tremendous amount of resources and costs without any public funding. It moreover contains proprietary information, including from third-party databases. It is therefore not possible to grant free public access to the Master DB.

3.3.4 Cut-offs

Cut-off rules are defined to provide practical guidelines to be able to omit specific less relevant process chain details while modelling a specific product system. ISO 14044: 2006 mentions three criteria used to decide which inputs are to be included: a) mass, b) energy and c) environmental significance.

There are three different situations where cut-offs are applied:

- 1) A known input or substance is not connected to an upstream process chain due to lack of information
- 2) A known inconsistency in a mass or energy balance with a known reason
- 3) An unknown or known inconsistency in a mass or energy balance with an unknown reason

The GaBi database has very few cut-offs of type #1. The only reason for cut-offs of type #1 is confidentiality of competitive formulations/substances (see table in Chapter 3.3.3). Due to the magnitude of the database content and the expertise of our engineers, most information is available or can be developed. If a substance for which no LCA data exists is needed and is not available as a dataset, the GaBi Master database uses information for a chemically/physically related substance and creates a conservative proxy dataset which rather slightly over estimates than underestimates the impact profile for the substance causing the gap. If the contribution of the conservative proxy on the overall result is smaller than 5%, the proxy will remain as the overall overestimate on the system level is marginal. If the influence on the result is higher, the data basis is enhanced (iterative process). Sphera acts on the principle “Only cut off what can be quantified.” More information on enhancing the data basis and close data gaps can be found below in the next chapter.

The GaBi Databases contain acceptable cut-offs of type #2 if the environmental contribution to the overall result can reasonably be expected to be irrelevant. An example of a justifiably negligible environmental relevance is a known inconsistency in a mass or energy balance with known reason, such as missing or imprecise quantified mass information in the input. These can be minor variations in moisture content or minor amounts of diffuse water input, or reaction or combustion air directly taken from the atmosphere which is normally not quantified in a “bill of

material” or process flow chart. Known inconsistencies in a mass or energy balance with known reason on the output side can be undocumented “emissions” or energy flows such as evaporated water, used air, “clean” off-gas streams or off-heat. These cut-offs are acceptable, if their quantification would raise the effort drastically and at the same time would only marginally improve the overall results.

All GaBi unit processes aim to adhere to physical and thermodynamic laws. The mass balance of the key substances and fuels in the input must match the product, waste and emission output. As a general rule in GaBi unit process modelling, the mass and energy balances are closed and cut-offs are avoided. Projects and data collections with industry and associations showed that on the unit process level, mass balance inconsistencies of less than 1% are achievable with practically feasible effort.

On the unit process level of GaBi datasets, a best practise value of < 1% cut-offs (or unknown omissions, sources or sinks) is applied for flows that are less environmentally relevant.

Diffuse emissions (which are not measured in practice but calculated or estimated according to local regulations) are considered if there is any indication that they are relevant in the respective process. Many processes limit or (virtually) prevent diffuse emissions by using specific sealing technologies or by operating with pressures below atmospheric condition (which can prevent unwanted substances to leave the system).

Unintentional cut-offs (mistakes) or unavoidable cut-offs (non-closable gaps) of type #3 (unknown or known inconsistency in a mass or energy balance for unknown reasons) are due to missing information or due to a mistake. If cut-offs must be applied in the foreground system, they are mentioned in the dataset documentation in GaBi <http://www.gabi-software.com/international/databases/> and limited as much as possible or feasible. If reviews, validations or applications of the GaBi Master Database reveal unintentional cut-offs, these are documented in the “GaBi database bug forum” and corrected one of the next maintenance cycles within the GaBi database maintenance and service schemes.

Straightforward application of mass-% cut-off rules can lead to significant inaccuracies if no possibilities exist to properly quantify or at least estimate the environmental relevance (e.g., through benchmarking). Therefore, the definition and use of cut-off rules should essentially be done or validated by experienced LCA professionals who know the respective process technology and the field of potential environmental effects caused by the related material and energy flows that are intended to be cut-off.

Only this combined knowledge ensures proper application of cut-off rules. Therefore, cut-off rules are indeed essential elements when preparing, collecting and validating data. These rules are especially important for processes with a large amount of different substance flows (such as pesticides in agriculture) or systems that employ large material flows of less environmental relevance and few minor mass flows of substances with potentially high impact (such as heavy

metals in a mineral mass production process or precious metals in catalyst production). In such cases, even small amounts (<1% mass) can sum up to relevant contributions due to their environmental relevance in comparison to the main mass flows.

3.3.5 Gap closing

Suitable application of cut-off rules defines the amount of relevant and included processes and process chains. The possibilities to avoid cut-offs were discussed in Chapter 3.3.4.

This chapter documents gap-closing, the procedure is as follows:

- All known raw materials, products and by-products are recorded (primary data is the first choice, if applicable).
- All known resources and emissions are recorded (primary data is the first choice, if applicable).
- In case no data is available, resources and emissions from similar processes or suitable literature data are used.
- Data can alternatively be calculated based on stoichiometry, mass-energy balances, known efficiencies and yield figures with adequate engineering expertise.
- Optionally, gaps are closed using a reasonable worst-case scenario (such as legal limit, which is in most cases higher than the actual value), while not with absolute worst cases (e.g. a by-product of unknown fate or NOT modelled as emission).
- The environmental relevance of the individual flows of concern and their sensitivities are quantified. Sensitivity analyses are supported by the GaBi software and can therefore easily be done during data collection and validation process.
- If the contribution and sensitivity is less relevant, the worst-case scenario may remain. If they are relevant, the flows of concern must be investigated in detail (maybe an iterative step of primary data acquisition needed).

The seven steps above are used in any customer specific “data on demand requests,” as well as for any new internal or external datasets, whose goal is to be consistent with the rest of the GaBi data and where the first choice, primary data, cannot be used.

3.3.6 Infrastructure

The inclusion or omission of infrastructure in the GaBi Databases is closely related to its respective relevance within the system, which can differ significantly. Infrastructure is relevant for processes that show comparatively fewer direct emissions during operation but involve material-intensive infrastructure per product output. This is the case for some renewable resource-based operations like hydropower plants (mainly reservoir), wind converters (blades,

tower, and gear), geothermal power plants (turbines halls, well equipment), and solar power plants (solar panels). For wind converters, most of all potential impacts (> 90%) are from infrastructure because virtually no relevant emissions appear in the use phase. For hydro and geothermal power plants, the impact of infrastructure can be up to 80%, in our experience. The impacts of storage hydropower plants especially depend upon the latitude of the site of the reservoir. The degree of relevance of degrading organic matter in reservoirs located in warm climates can reduce the infrastructure's relevance as far down as 20%. For geothermal power plants, the kind of geological underground situation (rocks, soil) may influence the share of impacts concerning infrastructure and maintenance.

The relevance of infrastructure of mainly fossil operated power plants is significantly lower; according to our records, it is well below 1% across common impact categories, as can be seen in 2 examples below:

Table B: Relevance of infrastructure for a natural gas power plant in the GaBi Master DB

	natural gas fuel supply	emissions + chemical supply operation	mainly concrete + steel infrastructure	EoL, recycling others
Acidification [kg SO₂-Equiv.]	79.7%	20.3%	0.06%	0.02%
Eutrophication [kg Phosphate-Equiv.]	60.1%	39.8%	0.05%	0.02%
Global Warming [kg CO₂-Equiv.]	21.7%	78.2%	0.02%	0.004%
Photochemical Ozone Creation [kg C₂H₄-Eq.]	83.6%	16.3%	0.05%	0.02%
Fossil Primary energy [MJ]	99.9%	0.1%	0.02%	0.003%

Larger plants with large throughput and longer lifetimes tend to have lower impact contributions from infrastructure than smaller plants with shorter lifetimes.

The above results can be cross-checked (e.g., by interested parties without access to LCA data) against publicly available power plant information from many internet sources. We consider the following figures of a medium power plant as a public domain example.

Table C: Publicly available example value for a medium size gas power plant

Cross check	Example value (considered as public domain)
Operation time	30-50 years
Installed capacity (electrical)	400-500 MW
Emissions Operation	400-450 kg CO ₂ emissions / MWh electricity output
Total emissions Operation	40-90 Mio. t CO ₂ over the lifetime of the power plant

Furthermore, we considered the following main material intensity of a power plant for the cross check of a public domain example.

Table D: Publicly available example values for CO₂ for a gas power plant

Cross check	Example value (considered as public domain)
Steel infrastructure	2,000 t to 4,000 t steel per 1 Mio kWh electricity output
Concrete infrastructure	16,000 to 20,000 t concrete per 1 Mio kWh electricity output
Asphalt infrastructure	1,000 t to 2,000 t asphalt per 1 Mio kWh electricity output

Considering additional publicly available CO₂ intensity factors of the ELCD database, for the aforementioned materials, the infrastructure is responsible for about 60,000 to 80,000 t CO₂, which amounts to about 0.09%-0.15% of the CO₂ emissions of the operation (neglecting the supply of gas and recycling possibilities of the power plant materials). If the gas supply and recycling were also included, the relative contribution of the infrastructure would be further reduced and a distribution similar to GaBi model above could be expected.

It is to be acknowledged that the relevance of infrastructure is strongly case-specific. However, even if one considers the side effects of construction of vehicles and machinery as several factors more impact-intensive than the material supply for infrastructure, infrastructure and construction would still have very low relevance for fossil fuel fired power plants.

Large-scale conversion processes show comparable characteristics of high throughput and long lifetimes, so we consider the infrastructure for those operations as irrelevant for a background database⁶.

Regardless of relevance, all energy datasets in GaBi Databases (fossil and renewable) include the power plant infrastructure for consistency reasons; for other product systems, it is included based on relevance, which can be given, with contributions of several %.

For other datasets that are essentially all about the infrastructure or other capital goods (e.g. wind power plants) the capital goods manufacturing and upstream is naturally included from the beginning.

3.3.7 Transportation

As a general rule, all known transportation processes have been included to remain consistent. Pipeline, ocean vessels, river boats, trucks, railroad and cargo jets are used as parameterised processes, meaning they are scaled and parameterised according to technology, distance, utilisation, fuel type, road type, river or sea conditions and cargo specifications.

⁶ Be aware: This documentation relates to a background database. For a specific goal and scope of a specific study it can of course be important to consider infrastructure (maybe even in the foreground system).

Transportation processes, including fuel production and utilisation, is especially relevant if the process in the considered system is known to be relevant due to:

- Weight of material/product to be transported or
- Distance of transportation.

The GaBi LCI database is structured into many sub-systems of producing and consuming systems, the transportation systems are modelled in the consuming system. This ensures the generic use of the same producing system in other applications while reflecting specific transportation situations in the consuming plan system.

3.3.8 Water

Water use is understood as an umbrella term for all types of anthropogenic water utilisation. Water use is generally differentiated in consumptive water use (i.e., water consumption) and degradative water use.

Freshwater consumption describes all freshwater losses on a watershed level which are caused by evaporation, evapotranspiration (from plants), freshwater integration into products and release of freshwater into sea (such as from wastewater treatment plants located at the coastline). Freshwater consumption is therefore defined in a hydrological context and should not be interpreted from an economic perspective. It does not equal the total water withdrawal, but rather the associated losses during water use. Note that only the consumptive use of freshwater (not seawater) is relevant from an impact assessment perspective because freshwater is a limited natural resource. Seawater is abundant and therefore not further assessed in life cycle impact assessment.

Degradative water use, in contrast, denotes the use of water with associated quality alterations, in most cases quality degradation (e.g., if tap water is transformed to wastewater during use). Quality alterations are not considered (fresh) water consumption. Also noteworthy is that the watershed level is regarded as the appropriate geographical resolution to define freshwater consumption (hydrological perspective). If groundwater is withdrawn for drinking water supply and the treated wastewater is released back to a surface water body (river or lake), then this is not considered freshwater consumption if the release takes place within the same watershed; it is degradative water use.

In a GaBi balance, the above terms can be understood as:

Freshwater use = total freshwater withdrawal = water (river water) + water (lake water) + water (ground water) + water (rain water) + water (fossil groundwater)

Freshwater consumption = total freshwater use (water input) – total freshwater release from technosphere (water outputs) = water vapour (including water evaporated from input products and including evapotranspiration of rain water from plants) + water incorporated in product outputs + water (freshwater released to sea)

Furthermore, water flows have been introduced for hydropower (e.g., “water (river water from technosphere, turbinéd)”) and a new approach to consider cooling water was implemented, which takes into account the latest developments of assessing thermal emissions to the aquatic environment.

Additional water flows in the GaBi Databases to enable consistent modelling of water

“Water (fresh water)”: This is a composite flow. Individual water elementary flows shall be documented (river/lake/ground water) and given priority. Use this flow only in cases where this differentiation is not possible. Freshwater is always classified as blue water (lake or river water, ground or fossil ground water).

“Water (fossil ground water)⁷”: The consideration of fossil groundwater is important because the use of fossil water directly contributes to resource depletion, which is specifically addressed by some LCIA methods.

“Water (tap water)”: We used the term “tap water” as general term encompassing tapped water with different qualities. It includes non-drinking-water quality water and high-quality drinking water produced from groundwater and/or surface or seawater by desalination.

“Water (wastewater, untreated)”: This flow is generally treated in a wastewater treatment plant. It shall not be used as an elementary flow since it has no characterization factors in the LCIA methods for water assessment.

Water vapour: Note that water vapour is not to be confused with steam. Water vapour is an elementary flow, whereas steam is a valuable substance flow.

Resource flows from technosphere: Water resource flows from the technosphere are introduced in order to facilitate complete water mass balances on the level of plan systems including foreground processes and aggregated background data (supply chains).

7 Fossil water or paleowater is groundwater that has remained sealed in an aquifer for a long period of time. Water can rest underground in "fossil aquifers" for thousands or even millions of years. When changes in the surrounding geology seal the aquifer off from further replenishing from precipitation, the water becomes trapped within, and is known as fossil water.

Water (evapotranspiration)⁸: Evapotranspiration can be an output from either rainwater or/and irrigation water stemming from e.g., rivers or lakes.

Water (brackish water): Brackish water has more salinity than freshwater, but not as much as seawater. It may result from mixing of seawater with freshwater, as in estuaries, or it may occur in brackish fossil aquifers.

To increase the consistency with the ILCD flow naming, the water flows were renamed with SP33 (GaBi Databases 2017); they retain consistency with the new EF 2.0 and EF 3.0 flow nomenclature, which is an expansion of the ILCD flow list. For further details regarding the names and structure of water flows in GaBi please refer to the Introduction to Water Assessment in GaBi Software [THYLMANN 2017] and to the separate documentation “Introduction to Water Assessment in GaBi”: <http://www.gabi-software.com/index.php?id=8375> .

Table E: Changes in water flows in GaBi (regionalisation of flows is not depicted in this table)

Original name (SP30, 2016)	New name (SP33, 2017 and later)
<i>Input</i>	
Water (fresh water)	Fresh water
Water (ground water)	Ground water
Water (lake water)	Lake water
Water (rain water)	Rain water
Water (river water)	River water
<i>Output</i>	
Water (lake water from technosphere, cooling water)	cooling water to lake
Water (river water from technosphere, cooling water)	cooling water to river
Water (groundwater from technosphere, waste water)	processed water to groundwater
Water (lake water from technosphere, waste water)	processed water to lake
Water (river water from technosphere, waste water)	processed water to river
Water (lake water from technosphere, turbined)	turbined water to lake
Water (river water from technosphere, turbined)	turbined water to river
Water (lake water from technosphere, rain water)	collected rainwater to lake
Water (river water from technosphere, rain water)	collected rainwater to river

8 Evapotranspiration (ET) is a term used to describe the sum of evaporation and plant transpiration from the Earth's land surface to atmosphere. Evaporation accounts for the movement of water to the air from sources such as the soil, canopy interception, and waterbodies. Transpiration accounts for the movement of water within a plant and the subsequent loss of water as vapour through stomata in its leaves.

Examples of how water was addressed in GaBi Databases:

Process using process water as input

- Input flow: Apply “water (process water)” and connect flow to a water treatment/supply module (see Figure 3-6)
- Output flow: Apply “water (waste water, untreated)” and connect flow to a wastewater treatment plant module (see Figure 3-6)

Process using tap water as input

- Input flow: Apply the appropriate GaBi dataset for tap water production (see Figure 3-6)
- Output flow: Apply “water (waste water, untreated)” and connect flow to a wastewater treatment plant module (see Figure 3-6)

Process using cooling water as input

Note that for cooling water we distinguish between use in 1) general production processes and 2) energy/electricity generation. Waste heat released to the water environment will also be properly recorded (see Figure 3-3) as both the information on the volume of released cooling water and the incorporated waste heat are necessary to perform the subsequent LCIA. Different technologies for cooling are differentiated as outlined below.

1) General production process (in different industrial settings)

Open-loop and **closed-loop cooling** are differentiated (see Figure 3-3).

- Input flow: Identify whether the cooling water input is...
 - directly withdrawn from the environment (e.g., from a river or lake) → then apply the appropriate water resource flow (e.g., “water (river water)”).
 - taken from a connected upstream water treatment process (e.g., water deionisation) → then apply the appropriate water technosphere flow/operating material (e.g., “water (deionised)”).
- Output flow: Identify whether the cooling water output is...
 - directly released to the environment (e.g., back to the river the cooling water was withdrawn from) → then apply the appropriate resource flow from technosphere (e.g., “water (river water from technosphere, cooling water”)). Consider also water vapour and waste heat, if applicable.
 - released as wastewater to the sewer system → then apply the flow “water (waste water, untreated)” and connect flow to a wastewater treatment plant module. Consider also water vapour and waste heat, if applicable.

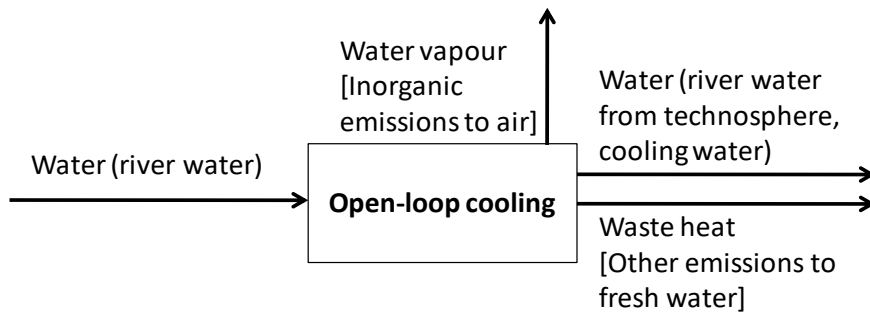

Water vapour: if no information is available, estimate **5 %** losses as water vapour due to evaporation/leakage.

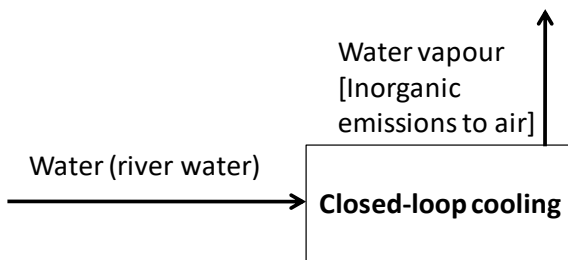

Water vapour: if no information is available, estimate **5 %** losses as water vapour due to evaporation/leakage.

Note that the amount of water vapour lost equals the amount of the resource input "water (river water)" due to the closed-loop set-up.

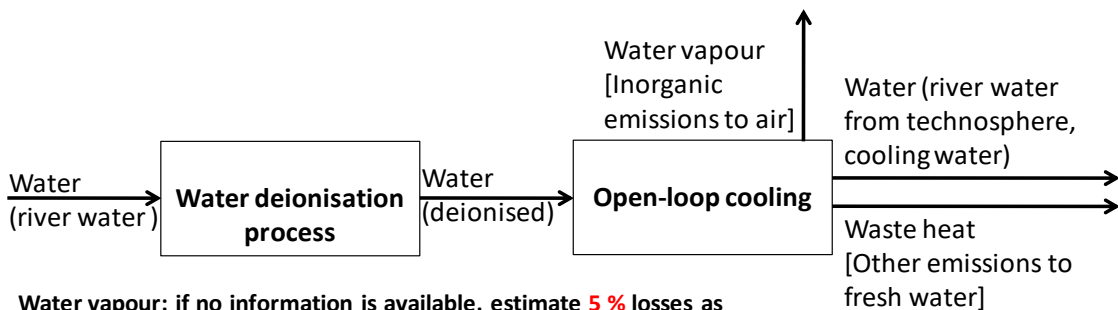

Water vapour: if no information is available, estimate **5 %** losses as water vapour due to evaporation/leakage.

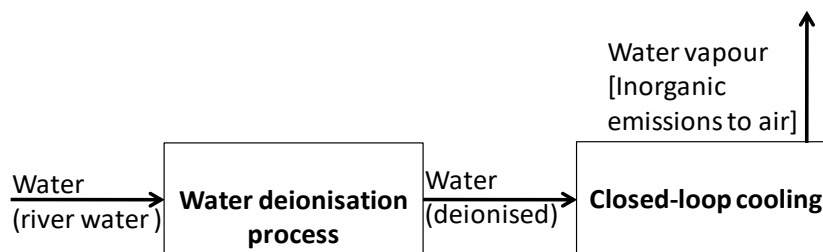

Water vapour: if no information is available, estimate **5 %** losses as water vapour due to evaporation/leakage.

Figure 3-3: Application of water flows in open-loop and closed-loop cooling systems

2) Energy/electricity generation:

Open-loop cooling system like once-through cooling and cooling towers (also denoted in electricity production are distinguished in Figure 3-4.

- Input flow: Identify which water source is used for cooling (e.g., river water, lake water) → then apply the appropriate water resource flow (e.g., “water (river water)”).
- In the case of cooling plants located at the coastline and using sea water for cooling purposes, consider a desalination process as an additional water treatment process and apply the appropriate water technosphere flow/operating material (e.g., “water (desalinated, deionised)”).
- Output flow: Apply the appropriate resource flow from the technosphere according to the water source used for cooling (e.g., “water (river water from technosphere, cooling water)”). Consider also water vapour and waste heat, if applicable.

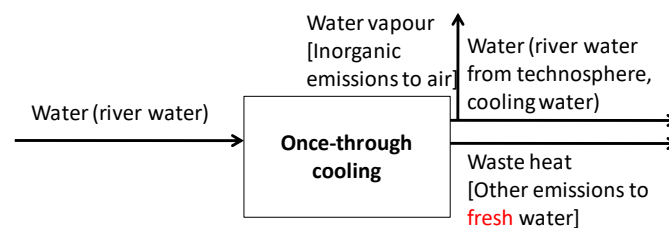

Water vapour: if no information is available, estimate 1 % losses as water vapour due to evaporation of heated cooling water from the river after release (Goldstein R., Smith W. 2002).

Waste heat embodied in the cooling water release according to heat balance.

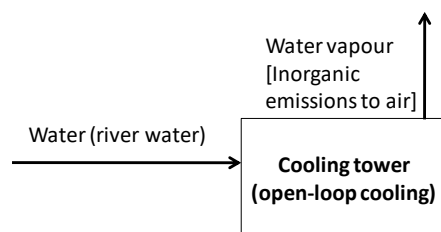

Water vapour: Amount of evaporated water equals amount of the resource input “water (river water)”.

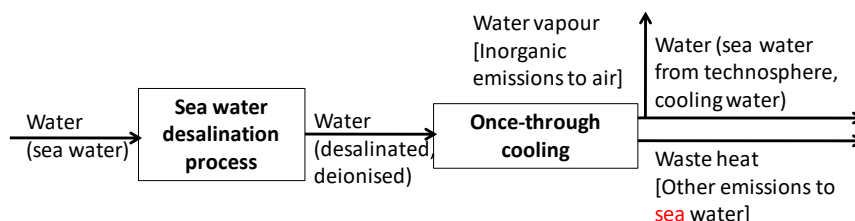

Water vapour: if no information is available, estimate 1 % losses as water vapour due to evaporation of heated cooling water from the sea after release (Goldstein R., Smith W. 2002).

Waste heat embodied in the cooling water release according to heat balance.

Output flow “water (sea water from technosphere, cooling water) denotes the origin of the water applied for cooling, namely the sea, and at the same time indicates that the cooling water is released back to the marine environment (assumption!).

Figure 3-4: Application of water flows in electricity generation

3) Use of water in hydropower generation

For hydropower generation, the following 4 generation technologies are considered: run-of-river power station, pump-storage and storage power stations, and tidal/wave power plants. See the following graphs for instructions for inventorying the appropriate water flows.

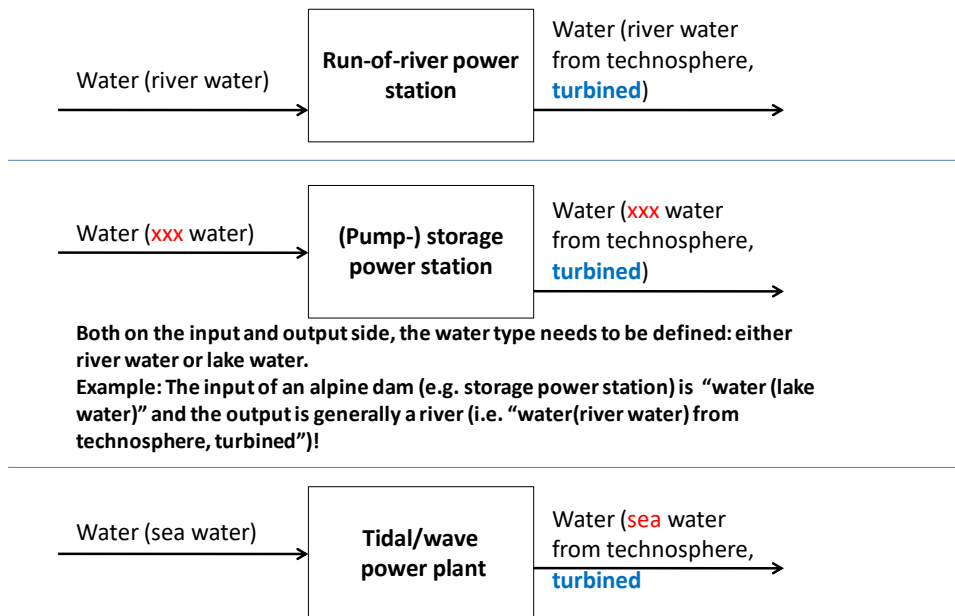

Figure 3-5: Application water flows in hydropower generation

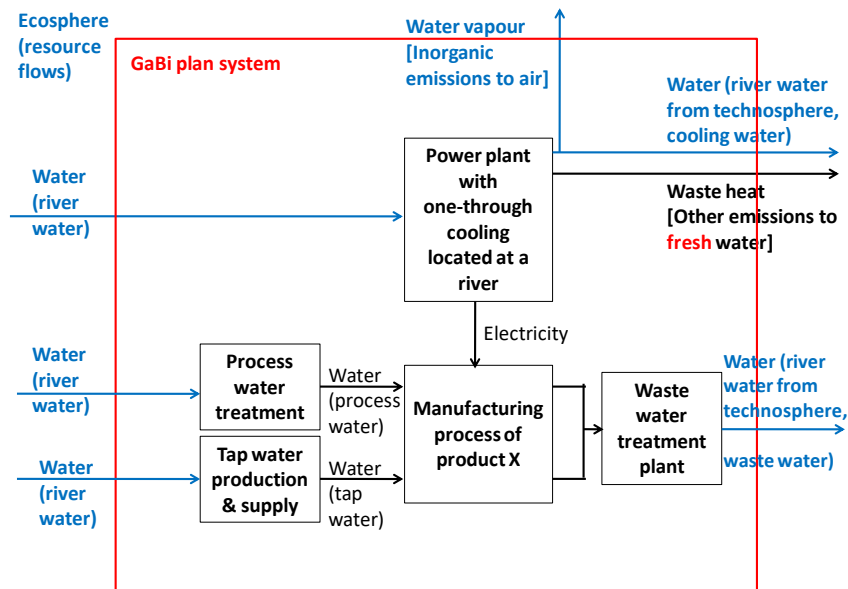

Figure 3-6: Ad hoc example of a simple plan system including different processes and water flows

In the GaBi Master Database, water that has been treated (chemically or physically deionised/decalcified) is generally used for process and cooling water purposes which reflect the standard case. Untreated water (tap or even surface water) is only used where it is explicitly known that it was used.

3.3.9 Wastes and recovered material or energy

Waste volumes or masses are known and commonly used to describe the environmental relevance of outputs of processes. However, waste volumes or masses are not an environmental intervention. The environmentally relevant intervention occurs in the incineration, treatment or landfill after waste is turned into emissions like landfill gas or leachate.

According to ILCD [ILCD 2010], and as adopted also e.g. for the PEF/OEF, all product and waste inputs and outputs shall be completely modelled until the final inventories exclusively show elementary flows (resources in the input and emissions in the output), for final results and valid comparisons.

Therefore, waste treatment is integrated throughout the whole system during modelling wherever possible and known to occur⁹. For all known treatment pathways (e.g., for regulated waste) the incineration and landfilling processes of the residues are integrated.

Different waste treatment options are provided in the GaBi Databases (inert matter landfill, domestic waste landfill, hazardous waste landfill underground / above ground, waste incineration of domestic waste, waste incineration of hazardous waste). The waste fractions of the processes are identified by the composition and their appropriate treatment modelled via the respective GaBi process.

“Waste” going to any kind of reuse or recycling can be modelled by:

- Looping the waste back to the system it came from (closed loop recycling)
- Doing a system expansion, modelling both burdens of the recycling and credits material/energy that is substituted.
- Allocating the waste as a by-product e.g. using an allocation according to price if the waste has a market value
- Cutting it off. Waste to be recycled without a market value is cut off (no associated burdens, no associated credits), which can be interpreted as an allocation according to market value where the waste gets 0% of the share.

There are many products which are legislatively considered a waste, but which must be treated as products in life cycle analysis because after a treatment it loses its waste status and becomes a resource/a product again. It should be noted that the same market value is applied at the point where the waste (or waste products) accumulates and at the point where the waste is recycled. Ideally for suitable modelling, feedback from both sides (producer of waste product

⁹ Due to the integration of treatment pathways for known waste or residue streams it might be possible that (intermediate) waste flows are deleted from existing plan systems (because those are now modeled further).

and user or processor of waste product) is necessary, to ensure that the modelling approaches of the 3 affected product life cycles are not contradicting each other.

3.3.10 Radioactive waste and stockpile goods

If waste treatment routes are unknown, unspecific or not definable, GaBi documents the related specific waste flow and the specific waste amount with a waste star “*” meaning it can be further treated if the user knows the specific waste treatment pathway. The final disposal of radioactive waste is not yet implemented due to lacking political and technical definitions. Thus, the radioactive wastes are a special group of GaBi waste flows are defined in Table F.

Table F: Definitions of the radioactive waste flows in GaBi

Flow name	Flow type	Description
High radioactive waste [Radioactive waste]	Waste flow	Originates predominantly in the end of life processing of radioactive waste in the nuclear power plant. A modelling of the final disposal site for nuclear waste can yet not be implemented due to lacking political and technical definitions.
Medium radioactive wastes [Radioactive waste]	Waste flow	Originates predominantly in the end of life processing of radioactive waste in the nuclear power plant. A modelling of the final disposal site for nuclear waste can yet not be implemented due to lacking political and technical definitions.
Low radioactive wastes [Radioactive waste]	Waste flow	Originates in the upstream supply chain of the nuclear fuel from uranium mining, milling, conversion, enrichment and fuel assembly as well as to a significant amount from the end of life processing of radioactive waste in the nuclear power plant. A modelling of the final disposal site for nuclear waste can yet not be implemented due to lacking political and technical definitions.
Radioactive tailings [Radioactive waste]	Waste flow	Originates in the upstream supply chain of the nuclear fuel from uranium mining, milling, conversion, enrichment and fuel assembly. A modelling of the final disposal site for nuclear waste can yet not be implemented due to lacking political and technical definitions.
Radioactive waste in GaBi standard datasets is therefore predominantly due to nuclear energy production, use and EOL in the respective aggregated data sets.		

Table G summarizes the definition of the Stockpile goods, which can be classified as a special group of GaBi elementary flows.

Table G: Definitions of the Stockpile goods elementary flows in GaBi

Flow name	Flow type	Description
Hazardous waste (deposited) [Stockpile goods]	Elementary flow	Treatment of incineration residues (e.g., via vitrification), stored at underground waste disposals or specific landfill sites
Overburden (deposited) [Stockpile goods]	Elementary flow	Material like soil or rock which is removed by mining processes (e.g., Hard coal, lignite, ores/minerals), typically not contaminated. In specific branches also called spoil (see below)
Spoil (deposited) [Stockpile goods]	Elementary flow	Material like soil or rock which is removed by mining processes (e.g., Hard coal, lignite, ores/minerals), typically not contaminated. In specific branches also called overburden (see above)
Tailings (deposited) [Stockpile goods]	Elementary flow	Represents a processing/beneficiation of the mined ore, e.g., copper, iron, titanium, chrome, lithium etc. Mechanical and chemical processes are used, results in a waste stream which is called tailings. Reagents and chemicals can remain in the tailing stream, as well the remaining part of metals/minerals and/or process water.
Waste (deposited) [Stockpile goods]	Elementary flow	Represents the remaining fraction of intern components (not converted into emissions, landfill gasses or leachate) which is stored in the body of waste disposal/landfill site.
<p>Wastes (deposited) in GaBi standard datasets are therefore representing occupying available landfill body or available stockpile place of components considered to be not reactive anymore or inert respectively.</p>		

Standard procedure (general waste treatment)

In general, waste materials are modelled to be recycled, incinerated, landfilled, or composted based in most cases on the predominant waste management pathway and in some cases (when no predominant pathway exists or where the relevance of the pathways to the overall result of the model is high) on the statistical share of each waste management pathway for the given geographical reference. In the case that specific information is not available for the respective situation, a standard procedure is adopted according to secondary material markets (see table below for material examples).

- Wastes for which a legal recycling pathway exists and a market for the secondary materials/energies is given are modelled as being recycled.
- All waste generated within the EU that has a calorific value and can be disposed with municipal solid waste (MSW) is treated in an incineration plant.
- If case-specific treatment is specified and known, and the waste cannot be mixed with MSW, specific treatment is modelled.
- All other waste (mainly inert waste) goes to landfill.

Table H: Default treatment procedures
for common materials/wastes

Material/waste	Treatment Process
Mixture of plastics	Incineration, waste to energy
Polyolefin and PVC	Incineration, waste to energy
Wood	Incineration, waste to energy
Aluminium, non-ferrous metals	Recycling
Steel	Recycling
Coating and sealing	Incineration, waste to energy
Glass, concrete, stones	Recycling and inert landfill

Standard procedure (Hazardous waste treatment)

The question if a waste stream is hazardous or non-hazardous is in many cases a legal question and does not alter the environmental burdens associated with the waste treatment. So with hazardous waste in this chapter we talk about the waste where treatment routes are considerably different from the usual incineration or landfilling. Hazardous waste streams are often hard to define as default in a background database because, depending on various options to mix different waste streams, several disposal options exist. Hazardous waste streams in the upstream chains are modelled according to their specific fate if it is known (e.g., in tailing ponds). Hazardous sludges are treated via vitrification, encapsulation and landfill. Hazardous slags are usually already vitrified and can be landfilled directly (best case); otherwise, treatment via complete vitrification is included (worst case). If unspecific hazardous waste streams appear, a worst-case scenario is used. The worst-case scenario models incineration, vitrification, macroencapsulation and the inert landfill of the remains. Carbon-rich and carbon-free hazardous waste is differentiated, as are other emissions that occur in incineration.

Table I: General procedure for some hazardous waste flows

Kind of waste	treatment	treatment	treatment	final treatment
Sludge		Vitrification	Macroencapsulation	Inert Landfill
Slag			Vitrification	Inert Landfill
Non-specific source	Incineration	Vitrification	Macroencapsulation	Inert Landfill

If hazardous waste treatments become relevant, a check must be performed to determine if specific data for the treatment pathway is available.

3.3.11 Selected aspects of biomass modelling

The carbon cycle in LCA can be defined as: CO₂ in atmosphere → CO₂ removals/H₂O/sunlight/surface → plant growth → harvested biomass → biomass use as fuel or material → CO₂ combustion/decomposition → CO₂ release to atmosphere → ...

Depending on the situation, one can understand “biomass” as a certain status at different points in the cycle: as a plant, as harvested biomass and as a renewable product.

The definition of “biomass resource” is therefore somewhat arbitrary and can be chosen according to the given goal and scope.

The input elementary flows of biomass in GaBi are carbon dioxide, water, solar primary energy and land use [GABI], not the biomass as such. This modelling assures mass balance consistency especially of the carbon balance. For example, biomass storage in materials and fuels and their incineration or decomposition releases of CO₂, which had been removed previously.

The solar primary energy embedded or stored in the biomass is exactly the amount of solar energy that has been converted by the biomass (i.e., its calorific value). The efficiency of conversion does not play a role, as the source (solar energy) can be understood as infinite in human timeframes. The amount of solar primary energy calculated in the balance of a biomass containing process in GaBi therefor accounts for the solar primary energy stored in the material as well as the solar primary energy used energetically in the subsequent process chain.

Biogenic carbon dioxide correction

Growing biomass removes CO₂ from the air; the carbon from the removed CO₂ is transformed into the plant tissue and is called biogenic carbon. The biogenic carbon comprises part of the product and eventually can be released into the air again as CO₂ (biogenic carbon dioxide) or as CH₄ (biogenic methane). For the sake of simplicity, this chapter speaks only of biogenic carbon, meaning both biogenic carbon dioxide and methane removals and release.



Figure 3-7: CO₂ removals

Biogenic carbon dioxide modelling approach

The biogenic carbon emissions (CO₂, CH₄) are tracked separately from the fossil ones. For incomplete life cycles of products that contain biogenic carbon (e.g., cradle-to-gate LCA of wooden pallets), the biogenic and fossil carbon emissions as well as the CO₂ removals are reported in the LCI.

Reasons why the biogenic carbon dioxide needs to be corrected:

- Allocation is applied: Allocation results in distorted carbon balances unless the carbon content is used as the basis for allocation, which is generally not the case.
- Default approach is used: Certain systems/products usually do not claim the carbon uptake even if it physically happens (e.g., food products or fast-consumed products). In the current carbon modelling approach, this credit is given by default, creating an error-source and a deviation from the approach typically used in the industry/product sector.
- Carbon credit is overestimated: Biogenic carbon emissions are often left untracked if loss of the biomass is involved (e.g., there is carbon from biomass that is leaving the system as sludge for disposal or as unidentified waste).

Below we describe the inherently complex and laborious carbon correction approach that is applied to all GaBi data that contain biomass. You can follow this procedure in order to close the carbon balance of your own modelled datasets. Hence, the correction approach is documented in all necessary steps. Please note that we also offer to support clients in this step for a fee.

As mentioned before, the biogenic carbon is tracked in different flows in GaBi:

- The carbon dioxide removals of growing biomass is modelled using: Carbon dioxide [Resources]
- Biogenic carbon dioxide emissions to air are modelled using: Carbon dioxide (biotic) [Inorganic emission to air]
- Biogenic methane emissions to air: Methane (biotic) [Organic emissions to air (group VOC)]

It is very important to have the information on the carbon and water content of the final material/fuel available. This information can either be found by looking at the flow (example see below, Figure 3-8) or through desktop research. For documentation purposes, it is highly advised to enter the information into the flow properties.

Quantity	vari	1 kg = *	Unit	Standar	1 [Quantity]
C_biogen_wt		0.421	kg	0 %	2.38
C_wt		0.421	kg	0 %	2.38
Energy (gross calorific value)		14.8	MJ	0 %	0.0676
Energy (net calorific value)		14.3	MJ	0 %	0.0699
Modified organic natural materials (unspecified)		1	kg	0 %	1
N_wt		0.0163	kg	0 %	61.3
Price		0.1	EUR	0 %	10
Water_wt		0.14	kg	0 %	7.14

Figure 3-8: Exemplary flow properties

The following quantities are used:

C_biogen_wt: amount of biogenic carbon (equivalent to C_wt if 100% biotic carbon)

C_wt: total amount of carbon in product (biotic and fossil)

Water_wt: water content of product (based on total wet weight)

The biogenic carbon correction approach covers modelling and evaluation of biogenic carbon dioxide for products where biogenic carbon forms part of a product (e.g., wood fibre in a cardboard box) from a cradle-to-gate perspective. It does not cover systems where atmospheric carbon is removed by a product during its use (e.g., carbonation of concrete).

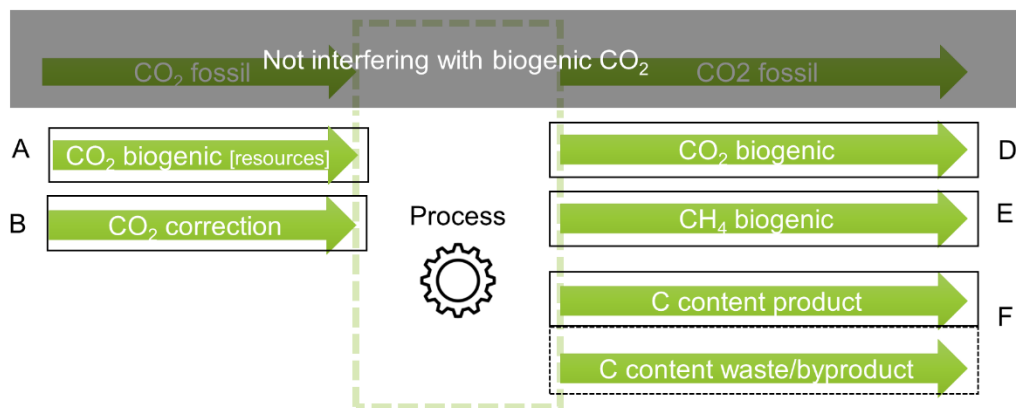

$$\begin{aligned}
 \text{CO}_2 \text{ correction} &= \text{CO}_2 \text{ out} + \text{CH}_4 \text{ out} + \text{CO}_2 \text{ accumulated} - \text{CO}_2 \text{ in} \\
 \text{B} &= \text{D} + \text{E} + \text{F} - \text{A}
 \end{aligned}$$

Figure 3-9: Basic concept of the carbon correction in GaBi

The approach corrects the flow **Carbon dioxide [Resources]** on the input side, following the carbon dioxide balance equation presented in Figure 3-9. The carbon correction process¹⁰ is part of the GaBi Professional DB and should be placed at the very end of the cradle-to-gate process chain per biobased material/fuel.

The formula, which is used for the correction, is explained here. This formula should be entered in the carbon correction dummy (explanation see below):

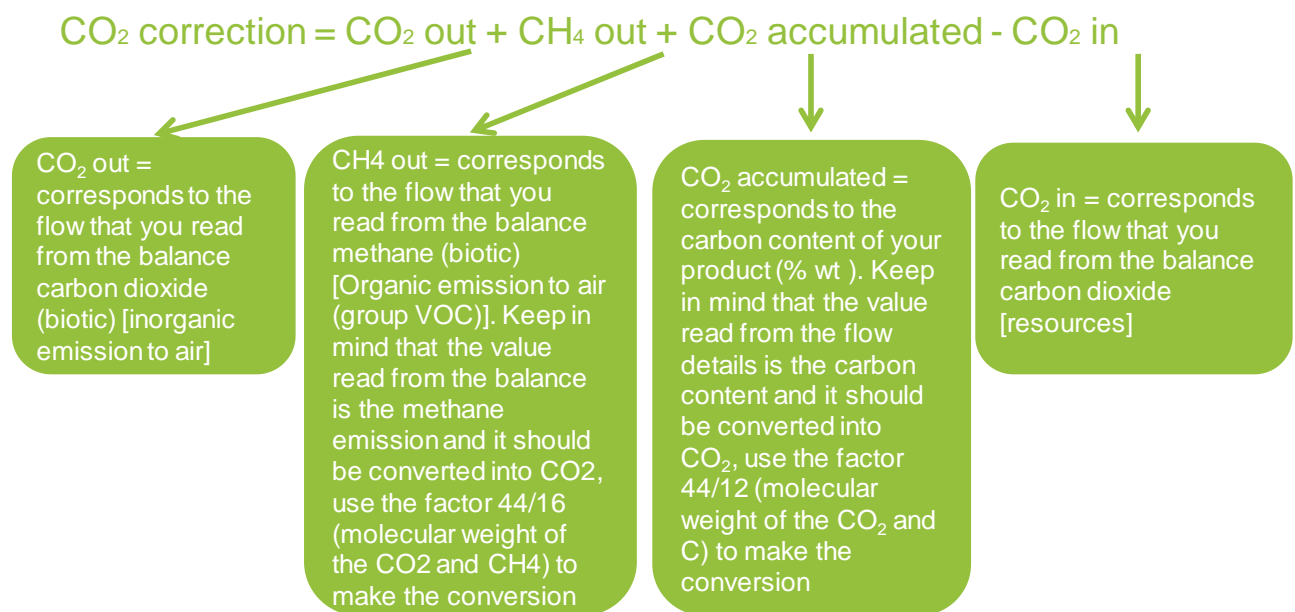

Figure 3-10: Carbon correction formula

How to correct the biogenic carbon in your model:

- 1) Check if the top plan level of your model is scaled to 1 kg product. If the scaling is different, the values of carbon dioxide on the input side and carbon dioxide and methane on the output side need to be divided by the product weight in order to scale them to 1 kg. The carbon content does not need to be adapted, since it is already entered as kg C / kg_{Product}.
- 2) Copy and paste the process Carbon balance correction (renewables), GUID: {cd49e1a9-23f3-4f3f-a250-b99b7895ec22} to your plan
- 3) Connect the product output flow to the process Carbon balance correction (renewables)

¹⁰ GLOCarbon balance correction (renewables) GUID {cd49e1a9-23f3-4f3f-a250-b99b7895ec22}

- 4) Run a balance, check “Separate I/O tables” on the Balance tab, and copy the values of the following flows:
 - Carbon dioxide [resources]
 - Carbon dioxide (biotic) [Inorganic emissions to air]
 - Methane (biotic) [Organic emissions to air (group VOC)]
- 5) Check the carbon content of the product. You can read this value from the product flow details or research it yourself.

Flows	267
Resources	134
Energy resources	0.00602
Land use	
Material resources	134
Non renewable elements	0.000101
Non renewable resources	0.0315
Renewable resources	134
Water	133
Air	0.779
Carbon dioxide	0.729
Nitrogen	2.47E-014
Oxygen	0.00898
Primary forest	1E-014
Others	
Deposited goods	0.0145
Emissions to air	117
Heavy metals to air	2.17E-006
Inorganic emissions to air	116
Ammonia	0.000122
Ammonium	3.36E-011
Ammonium nitrate	6.05E-019
Argon	1.28E-009
Barium	4.69E-007
Beryllium	2.23E-011
Boron	1.96E-015
Boron compounds (unspecified)	2.7E-009
Bromine	6.45E-010
Carbon dioxide	0.0186
Carbon dioxide (aviation)	1.33E-008
Carbon dioxide (biotic)	0.173
Carbon dioxide (land use change)	0.125
Carbon dioxide (peat oxidation)	2.11E-011
Carbon disulphide	5.02E-019

Figure 3-11: Balance view for carbon correction I

Sulphur	3.12E-012
Sulphur dioxide	7.49E-005
Sulphur hexafluoride	7.93E-016
Sulphur trioxide	1.03E-009
Sulphuric acid	1.11E-011
Tin oxide	2.87E-023
Water (evapotranspiration)	116
Water vapour	0.344
Zinc chloride	2.02E-026
Zinc oxide	5.73E-023
Zinc sulphate	4.17E-012
Organic emissions to air (group VOC)	0.000828
Group NMVOC to air	0.000379
Hydrocarbons (unspecified)	1.51E-007
Methane	4.31E-005
Methane (biotic)	0.000406
Other emissions to air	0.386
Particles to air	0.00102
Pesticides to air	7.7E-011
Radiative emissions to air	1.71E-016

Figure 3-12: Balance view for carbon correction II

- 6) Open the process “GLO: Carbon balance correction (renewables)” by double-clicking on the process instance and enter the values from the balance and the carbon content of the product in the “Free parameters” section at the top in the column “Value”.

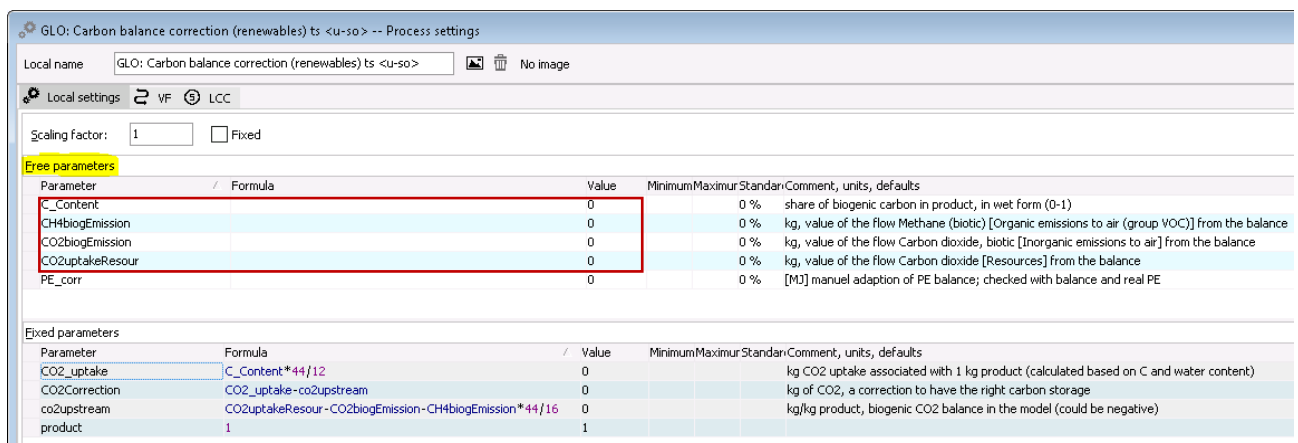

Parameter	Formula	Value	Minimum	Maximum	Standard	Comment, units, defaults
C_Content		0		0 %		share of biogenic carbon in product, in wet form (0-1)
CH4biogEmission		0		0 %		kg, value of the flow Methane (biotic) [Organic emissions to air (group VOC)] from the balance
CO2biogEmission		0		0 %		kg, value of the flow Carbon dioxide, biotic [Inorganic emissions to air] from the balance
CO2uptakeResour		0		0 %		kg, value of the flow Carbon dioxide [Resources] from the balance
PE_corr		0		0 %		[MJ] manual adaption of PE balance; checked with balance and real PE

Parameter	Formula	Value	Minimum	Maximum	Standard	Comment, units, defaults
CO2_uptake	C_Content*44/12	0				kg CO2 uptake associated with 1 kg product (calculated based on C and water content)
CO2Correction	CO2_uptake-co2upstream	0				kg of CO2, a correction to have the right carbon storage
co2upstream	CO2uptakeResour-CO2biogEmission-CH4biogEmission*44/16	0				kg/kg product, biogenic CO2 balance in the model (could be negative)
product	1	1				

Figure 3-13: CO₂ correction process - parameters

How you know that the biogenic carbon dioxide was corrected:

- 1) Once you entered the values in the carbon balance correction process, run a balance again
- 2) Read the following values
 - Carbon dioxide [resources]
 - Carbon dioxide (biotic) [inorganic emission to air]
 - Methane (biotic) [Organic emissions to air (group VOC)]

- 3) Calculate the difference between input and output flows
- 4) Check if the differences correspond to the carbon content of your product (use the conversion factor 44/12), if so the biogenic carbon was successfully corrected

If you adapt a model that was carbon corrected already but the carbon balance is not closed anymore due to newly introduced changes in the model, you have to repeat the procedure above.

In terms of impact categories, GaBi offers each GWP metric with and without biogenic carbon dioxide. Biotic methane is always characterized as its release is never carbon-neutral.

All plans and aggregated processes in the GaBi Databases have a closed carbon balance. You only have to check the balance for newly modelled or adapted plans based your own data, where allocation is involved, or if you use partly aggregated biomass processes where the choice of biomass input is left up to the user.

Heavy metal uptake in biomass modelling

Renewables extract heavy metals from the ground when growing. The amount of this uptake is specific to the species, the heavy metal content of the soil, and even the site conditions. It can be measured as heavy metal content of the renewable material. Whether these heavy metals are in the soil for a long time or whether they are freshly deposited, e.g., from fossil energy generation emissions or from fertiliser application, is not known and methodologically not of relevance.

In Sphera datasets, this uptake is currently modelled as negative emission of heavy metal to ground. As a consequence, the toxicity results of the renewables datasets are affected and in cradle to gate datasets the toxicity can be overall negative, e.g., if the emissions from the end of life of the product downstream are not consistently modelled, as a side effect from allocation or for other reasons. This is largely analogous to the situation of modelling of carbon dioxide uptake into renewables that was described earlier in this chapter. However, in models that take into account the whole life cycle of the renewable material, one would assume that all the heavy metals that are incorporated in the material are released again as an emission to ground/water/air, and that the overall toxicity results in a cradle to grave model are always positive. This is not always the case:

- If the heavy metals are incorporated in waste that is landfilled, then a large part of the heavy metals are not mobile and stay incorporated in the landfill body.
- If the heavy metals are incorporated in waste that is entering a new life cycle, then, according to the used method, the second life cycle is either cut off or after modelling the burdens of recycling a credit is given for the material that is substituted. In both cases,

the incorporated heavy metals are not released in the life cycle of the renewable itself, but are shifted to the life cycle where the waste is used.

Therefore, also cradle to grave models can have negative toxicity results. **The negative results are not wrong if a technical explanation for the negative results can be given. The negative results can lead to difficulties in the interpretation of the results, so practitioners would like to avoid these.**

Currently in the scientific LCA community, there are discussions on how to do this best. In the Guidance document 6.3 of the European Product Environmental Footprint [PEFCR Guidance 2017] (chapter 7.10.6), two options are given:

- 1) Not to model the heavy metal uptake when the final emissions are not accounted for;
- 2) Model the heavy metal uptake when the final emissions are accounted for (this is what Sphera is currently doing)

Option 1 would solve the problem but has a couple of drawbacks:

- The uptake of the heavy metals might be a feature of the system under study (e.g., when plants are used to clean contaminated soil). This could not be modelled at all.
- The final emissions of the heavy metals are an important distinction of different production routes and their ability to avoid or reduce heavy metal emissions to ground/water/air. Leaving these emissions out of the scope would certainly reduce the significance and technical correctness of the whole study.

Modelling the emissions but not modelling the uptake is also not a straightforward solution, since it is inconsistent with the current method for biogenic carbon, where both carbon dioxide uptake and emissions are modelled. It also doesn't follow the physical reality since there is a heavy metal content in the renewable materials and the mass balance for the heavy metals is not closed.

Another idea is to not model the uptake as negative emissions, but to use resource flows for the heavy metals, which is consistent to carbon uptake. Then the heavy metal resources could have negative characterization factors for toxicity. This does not solve the problem but simply shifts it from life cycle inventory to life cycle impact assessment. It would however add some transparency since the amount of uptake would be directly visible and the effect of the uptake could be assessed when interpreting the results. The negative side of this idea is that the results of the abiotic resource depletion for the renewables would dramatically change.

This shows that there currently is no solution available. Sphera is part of the scientific discussion around this topic and as soon as a consensus or a practicable solution is found, the solution will be implemented in the maintenance cycle of the databases.

3.3.12 Aspects of primary energy of fossil and renewable energy sources

Energy evaluation in the GaBi database is based on the principle of “cumulated energy approach (KEA)” or often also referred to as embodied energy. The primary energy needed to supply certain materials or energies often serves as indicator of the energy efficiency. The indicator can be misleading if renewable and non-renewable energy sources are compared or summed and not separately interpreted. Renewable and non-renewable energy sources can be interpreted combined or separately following the goal&scope of the study, both ways are implemented in the GaBi database. The interpretation is usually done in LCA reporting.

It is relatively common to compare non-renewable energy production procedures with a uniform parameter like the calorific value of the primary energy needed to provide a certain usable energy. However, such a uniform parameter does not intuitively exist for renewable energy sources like hydro and wind or for nuclear energy. Different approaches exist (technical efficiency¹¹, physical energy content method with virtual 100% efficiency for renewables, substitution approach to avoid renewable efficiencies with virtual thermal fossil efficiencies for renewables¹²) to define or compare the primary energy demand of a related usable energy form.

In principle, the method of the technical efficiency differentiates between renewable and non-renewable primary energy needs, while others do not.

ISO 14040 frameworks do not call for an explicit method for the aggregation/separate representation of the primary energy.

The ILCD framework [ILCD 2010] does not call for an explicit method either, but a recommendation is given for a differentiation between non-renewable energy resources and renewable energy resources.

In GaBi, consequently the method of the technical efficiency with differentiation between non-renewable energy resources and renewable energy resources is applied as it illustrates the situation adequately, comprehensively and transparently. This is especially important in countries with significant portions of renewables in the grid (e.g., Norway, Austria and Denmark). The international trade of energy is accounted for individually to avoid a virtual efficiency of 100% for imported electricity, which is relevant for countries with a high share of imported energy.

The value and burden of the use of 1 MJ of renewable primary energy is not directly comparable with 1 MJ of fossil primary energy because the availability of the fossil resources is limited and

11 See Richtlinie, VDI 4600, 1997: VDI 4600 Kumulierter Energieaufwand - Begriffe, Definitionen, Berechnungsmethoden.

12 See Murtishaw, S.; et al.: Development of Energy Balances for the State of California. Lawrence Berkeley National Laboratory. Berkeley, USA, 2005. Online at <http://escholarship.org/uc/item/6zj228x6>, latest access on 2010-09-07.

depletion occurs. The topic cannot be discussed in detail here, but the guidelines will help to prevent “double counting” as well as “perpetual motion.”

1 MJ of electricity from wind power is produced using approx. 2.5 MJ of primary wind energy (an efficiency of approx. 40%, due to usable kinetic energy of wind).

For 1 MJ of electricity from hydropower (virtually) 1.15 - 1.25 MJ of primary hydro energy is used (an efficiency of 80 - 85% based on the usable kinetic energy of water).

For 1 MJ of electricity from geothermal power (virtually) 5 – 6.5 MJ of primary geothermal energy is used (an efficiency of approx. 15 - 20% based on the energy content of usable temperature gradient).

For 1 MJ of electricity from nuclear power approx. 2.5 - 3.3 MJ of primary nuclear energy is used (an efficiency of approx. 30 - 40% based on the energy content of used fissile material).

For 1 MJ of electricity from photovoltaic approx. 10 MJ of primary solar energy is used (an efficiency of approx. 10% based on the usable part of the solar radiation).

For 1 MJ of electricity imports the specific efficiency of the import country is applied.

3.3.13 Land Use using the LANCA® method

Apart from the classical impact categories like Climate Change, Eutrophication, Acidification etc. land use as an environmental issue is widely considered important and constantly gains attention in the Life Cycle Assessment community.

In the software and database system GaBi, the EF/ILCD elementary flows for land use are integrated and characterization factors (CF) for the LANCA® (Land Use Indicator Value Calculation in Life Cycle Assessment) indicators are provided. The methodology behind LANCA® is based on the dissertation of Martin Baitz [BAITZ 2002] and subsequent work that was carried out at the University of Stuttgart, Chair of Building Physics (LBP) (now Institute for Acoustics and Building Physics (IABP)), Dept. Life Cycle Engineering (GaBi) [BOS ET AL. 2016] and [BECK, BOS, WITTSTOCK ET AL. 2010]. A detailed description of the underlying methods as well as the characterization factors can be found in [BOS ET AL. 2016] and [BECK, BOS, WITTSTOCK ET AL. 2010] and in [BOS 2019]. The following set of indicators has been defined to model land use aspects in LCA:

- Erosion Resistance
- Mechanical Filtration
- Physicochemical Filtration
- Groundwater Replenishment

- Biotic Production

On the inventory side, country-specific land use flows are used for “occupation” with the unit $m^2 \cdot a$ and for “transformation from” and “transformation to” with the unit m^2 for all different land use types, e.g., “arable, irrigated, intensive” or “forest”. The respective country-specific characterization factors are integrated into the GaBi database and software in the impact assessment and aggregated over the process chain to form environmental indicators that are representative for the entire life cycle. In the GaBi background processes, land use information is addressed for all biomass and mining process as well as in the EoL processes covering water treatment, landfill and incineration. Through the iterative aggregation of the plan systems in the MasterDB, land use information is integrated into most of the aggregated processes. Therefore, land use can be considered as an additional aspect in LCA to extend its environmental impact evaluation.

LANCA® currently addresses terrestrial biomes but not aquatic ones. However, this could be a further development process and therefore all water body/seabed flows are integrated characterized with the value “0”.

All indicators are calculated for the transformation and occupation phase. One set of CFs is related to the “occupation” phase, one set to the “transformation from” phase and one to the “transformation to” phase. In order to explain the concept of transformation and occupation as well as the used data the relevant paragraphs of LANCA® are recommended:

<http://publica.fraunhofer.de/documents/N-379310.html>

You can also find an update of the characterization factors there.

LANCA® is a regionalized method and uses regionalized flows in the GaBi processes that are marked as “ts” indicating Sphera as the data source. More than 60 countries were selected based on their economic significance and coverage in the GaBi database. All EU28 countries are included in alignment with the PEF methodological guidelines. For other countries please use the nonregionalized flows and indicate your needs to gabi-data@sphera.com, so that Sphera can expand the list of countries in the upcoming years accordingly.

Datasets from other data providers published in GaBi currently do not use regionalized flows. Land use assessment is possible for these datasets as well, but only using non-regionalized flows with global characterization factors. Consequently, the interpretation of land use results comparing Sphera datasets with datasets from other providers needs to be done with caution. Sphera believes that regionalization is a very important topic for land use assessment and will work towards a common use of regionalization in the future; the EF 3.0 database, composed of the official EF secondary data provided by Sphera and other providers includes regionalized land use flows across the data sets already.

With the 2017 release of GaBi Databases, the assessment of land use made a big step forward: on the basis of the EF/ILCD flow list, a mapping/conversion of all land use flows of different method developers and dataset providers into a common set of flows was possible. With this, the parallel assessment of land use is now possible in GaBi for the different LCIA methods LANCA, EF 2.0 and 3.0 Single Quality Index Land Use (based on LANCA), ReCiPe, UBP, Impact 2002+ and EPS. The practitioners that have assessed land use before will recognise that the land use folders “hemeroby” and “hemeroby ecoinvent” are no longer there, since they have been merged with the other land use folders “Occupation” and “Transformation”.

Land use is regarded as a resource category. Therefore, the flows for both occupation and transformation are located at the input side of processes and balance view. This is also true for the “transformation to” flows. Because of this convention, the characterization factors of the “transformation from” and the “transformation to” have a different algebraic sign (one is positive, the other negative). Please see also our separate documents on land use and land use change: <http://www.gabi-software.com/index.php?id=8375>

3.3.14 Land Use Change (LUC)

For a variety of reasons, there is an increasing demand of crops for the production of food, for biofuels or for feedstock in materials. The replacement of natural land by agricultural systems or change from one to another agricultural system leads to land use change. Together with the change of the land use, system changes in the carbon stock, biodiversity and socio-economic effect might occur. These effects can be subdivided into:

- direct Land Use Change (dLUC):
Change in human use or management of land within the boundaries of the product system being assessed
- indirect Land Use Change (iLUC):
Change in the use or management of land which is a consequence of direct land use change, but which occurs outside of the product system assessed” [OVID 2013]

3.3.14.1 Direct Land Use Change

The calculations for carbon stock changes are based on IPCC rules: The basic approach is to determine the total carbon stock change by assessing the difference between carbon stocks of the agricultural area - including both, soil and vegetation - of the previous and the changed situation. The assumptions for carbon stocks are dependent upon country, vegetation type, climate & soil type. The approach is crop-specific: The impacts from land use change in a specific country are allocated to all crops in this country, for which the value of 'area harvested' increased over time. This allocation is dependent on the crop's respective share of area increase in this country.

Underlying sources for the calculations are statistical data for crop yields, harvested area of crops from FAOSTAT, the area of forest and grassland from FAO's global forest resource assessment (Data from the Global Forest Resource Assessment of the FAO. See also <http://www.fao.org/forestry/fra/fra2010/en/>) [FAO 2012], the respective carbon stocks from EC JRC world map of climate types and world map of soil types (from EC JRC <http://eusoils.jrc.ec.europa.eu/projects/RenewableEnergy>), the above ground mass carbon stock, values of soil organic carbon stock and stock change factors from IPCC 2006. Changes in soil organic carbon stock are taken into account in this methodology. The emissions are calculated in a process and connected with the agrarian plant model per hectare and are scaled per reference unit respectively.

On LCI level, the emissions are reported separately with the flow "carbon dioxide from land use change" as required by certain standards. The emissions are per default directly released as carbon dioxide. In case different information is available, partly incineration is applied and is explicitly described in the respective dataset.

The analysis on LCIA level is described in chapter 3.3.14.3.

References:

- IPCC 2006: IPCC Guidelines for National Greenhouse Gas Inventories. 2006. Chapter 4.
- Global Forest Resource Assessment, 2010. FAO:
<http://www.fao.org/forestry/fra/fra2010/en/>
- ISO/TS 14067 (2013) ISO 14067 Greenhouse gases – Carbon footprint of products – requirements and guidelines for quantification and communication, 2013.
- EC JRC (2013) Soil Projects; Support to Renewable Energy Directive
<http://eusoils.jrc.ec.europa.eu/projects/RenewableEnergy/>. Accessed 15 July 2014.

3.3.14.2 Indirect Land Use Change

Indirect land use change is not considered in the LCI data of the GaBi Databases. This chapter will provide an outline why indirect LUC is currently not considered.

Finkbeiner [Finkbeiner 2014] analyzed the scientific robustness of the indirect LUC concept and its consistency with international accounting standards for LCA: "The conclusion was that globally agreed accounting standards for LCA and carbon footprints do exist, while there are currently no accounting standards for indirect LUC at all". There is hence no requirement by standards to include indirect LUC results.

Finkbeiner further concluded: "There is just one thing which is commonly agreed: the uncertainty of indirect LUC quantification approaches and their results. There is full agreement in the scientific community that the uncertainty is way beyond a level that is usually aimed for in quantitative science." The scientific robustness was hence argued of being insufficient for political and corporate decision-making [Finkbeiner 2014].

As there is no commonly agreed methodology, the data basis is not sufficient for inclusion of indirect LUC data in the GaBi Databases. Any data would overly have to rely on assumptions etc. Indirect LUC calculations may be done on project basis.

We will continue to monitor developments, and if any agreement develops, and robustness is ensured, we will include indirect LUC.

3.3.14.3GWP effects in agriculture, horticulture and silviculture

In agriculture, horticulture and silviculture additional GWP effects are to be considered, compared to fossil-based products.

Due to the renewable nature of the products, the biogenic carbon cycle is taking place much faster than the fossil carbon cycle. Besides the known standard emissions of fossil CO₂, CH₄ and alike, additionally CO₂ intake/uptake from atmosphere appears to build up the plants. Animals eat plants and grow. Anaerobic transformation from carbon into CH₄ happens in animals and in certain situations of rotting and decomposition. Carbon storage in the products and carbon losses influences the carbon balance. Biotic CO₂ emissions and biotic CH₄ emissions have to be differentiated from fossil emissions. Land use changes have an effect on the carbon balance, because different land use types release additional CO₂ amounts due to reduced carbon storage capabilities.

The following paragraphs describe the various aspects in more detail and summarize all GWP related aspects in an overview table.

Fossil GWP related emissions

Concerning fossil GWP emissions, the established standard approach is consistently applied to agriculture, horticulture and silviculture system as well.

Biotic CO₂

Concerning biotic CO₂, the removals and releases have to be considered. Generally, in GaBi the carbon removals from the atmosphere and the biotic emissions are modelled. This is done by using on the input the flow “carbon dioxide [renewable resources]” and on the output side the flow “carbon dioxide (biotic) [Inorganic emissions to air]” for all biotic CO₂ emissions. Carbon containing wastes and losses are modelled with the appropriate flows (and their respective carbon content) accordingly. An illustration is shown in Figure 3-15.

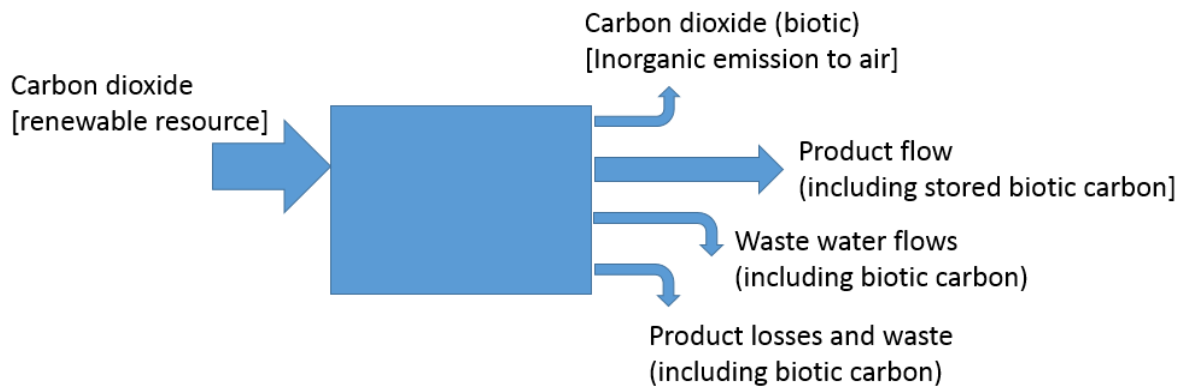

Figure 3-14: Example of different biotic carbon flows in GaBi

Biogenic CH₄ emission

Concerning biotic CH₄, only emissions have to be considered, as no CH₄ is removed from the atmosphere in nature. Biotic CH₄ is created under anaerobic conditions, turning carbon (which was initially removed from the atmosphere by the plant/fodder in form of CO₂) into CH₄ in certain decomposition processes, aqueous field techniques, landfill processes, or in animal digestion. Generally, we model the biotic CH₄ emissions using the flow “Methane (biotic) [Organic emissions to air]” (as shown in Figure 3-16).

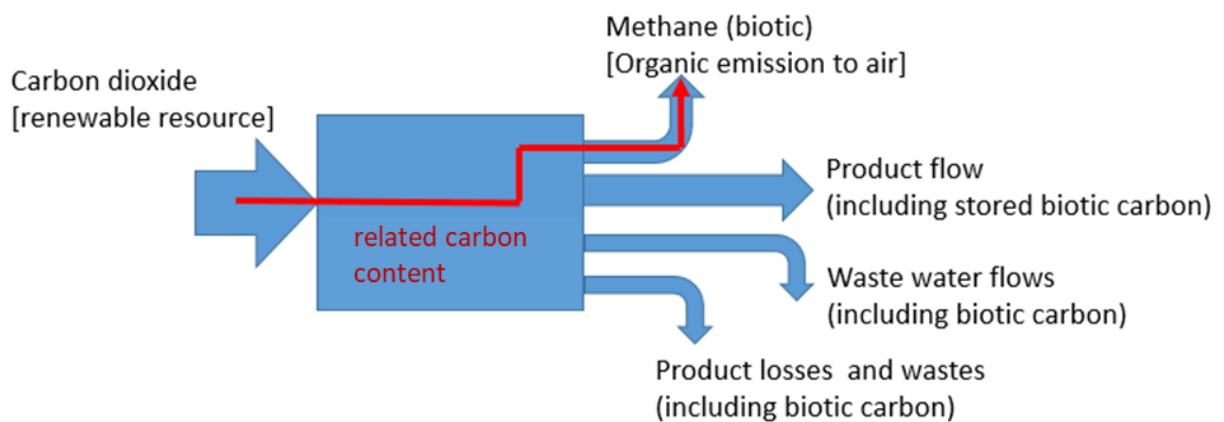

Figure 3-15: Example of methane biotic emissions to air

Land use change related CO₂ emissions

Due to certain land use change activities, releases of carbon stored in vegetation and soil in the form of CO₂ or CH₄ may occur. Typical examples are the conversion from rain forest into plantations, the conversion of deciduous forest into a quarry, or the drying of a swap or peat bog. Those changes imply a change in the capability to uptake and store carbon in the vegetation or soil and to release the difference into the atmosphere, respectively.

Underlying methodologies and databases for the calculation of these effects can be different. From result interpretation point of view, the main difference in the inventory in GaBi is the related accounting of land use change CO₂ either as:

a) **Carbon dioxide (land use change) [Inorganic emissions to air]** for all data based on the approach described in chapter 3.3.14.1. and **Carbon dioxide (peat oxidation) [Inorganic emissions to air]** if transformation occurred on peatland (see Figure 3-16). Peat oxidation emissions occur over a longer period of time. The latter flow is only used in a very limited number of datasets.

b) **Carbon dioxide [Inorganic emissions to air]** – for all datasets which are based on other methods or data; the respective approach is described in the documentation of the respective dataset (see Figure 3-17).

Option a) follows a more consistent approach but is built on more generic data. Option b) has a longer history, some data already existed and are used in practice. These datasets are based on detailed research and context-specific decisions and are clearly indicated by adding “incl. LUC as fossil CO₂” to the process name in GaBi. Therefore, we accept/respect datasets including information of method b), however new land use change data in GaBi is primarily produced by method a) (see section 3.3.14 for details).

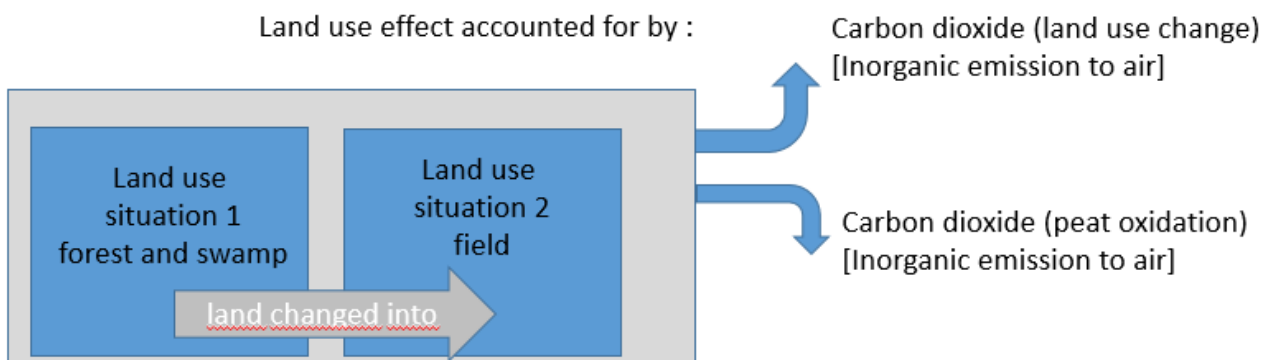

Figure 3-16: Example of LUC emissions occurring with additional LUC flows

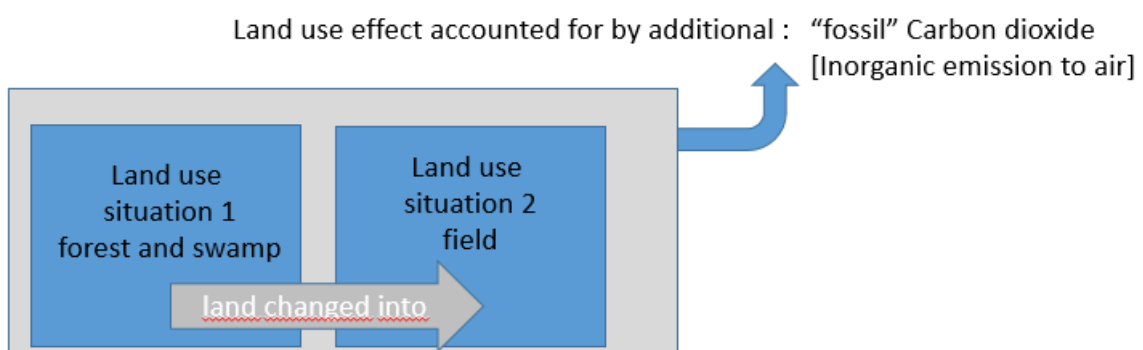

Figure 3-17: Example of LUC emissions occurring without an additional LUC flow as fossil CO₂

A mix of both approaches in one dataset or supply chain is not used. So if land use change is a relevant impact in the related supply chain and data set the effects are either accounted for under fossil Carbon dioxide or alternatively under Carbon dioxide (land use change) and/or Carbon dioxide (peat oxidation).

Due to the fact that land use change is very important for one group of users and perceived as less relevant and potentially confusing for other users we added additional impact categories to enable the user to either include or exclude land use change effects and to still keep comparisons to former results consistent.

Below is an example for CML (but this is similar for other GWP impact assessment methods, as for example EF2.0 and EF3.0 Climate Change):

Next to the existing standard Global Warming categories...

- 1) CML2001 - Apr. 2013, Global Warming Potential (GWP 100 years)
- 2) CML2001 - Apr. 2013, Global Warming Potential (GWP 100 years), excl. biogenic carbon

...three new Global Warming categories are consistently introduced:

- 3) CML2001 - Apr. 2013, Global Warming Potential (GWP 100), incl. biog. C, incl. LUC
- 4) CML2001 - Apr. 2013, Global Warming Potential (GWP 100), excl. biog. C, incl. LUC
- 5) CML2001 - Apr. 2013, Global Warming Potential (GWP 100), Land Use Change only

Example: If you do not like to look at land use change effects, you should use 1). If you like to include them you would use propose 3).

This solution serves to keep results of previous studies “comparable” without changing the impact assessment. Additionally, this approach enables conformance to your specific schemes or modelling approach used as well as full transparency over the related aspects and newest scientific findings in global warming effects in relation to the rising awareness of land use changes.

3.4 Sources and types of data

Many sources and types of data exist. Whether the source or type of data is suitable is a matter of the goal and scope of the exercise, and the capability of the data modeller to turn raw data and process information into LCI data. The raw data and resulting LCI data used in the generic GaBi background databases seek to reflect the reality of a certain point in time as representatively as possible.

3.4.1 Primary and secondary sources of data

(Primary) data and information from industry sources is the preferred choice of GaBi raw data and background data, wherever possible and approved.

Primary data can be collected via the classical approach of collecting data from several companies producing the same product and averaging the resulting inventories. Primary data is obtained from specific facilities as a primary source of information. This data is measured, calculated or acquired from the bookkeeping of a particular facility.

Secondary data is obtained from published sources and used to support the set-up of the LCI. Examples of secondary data sources include published literature, environmental reports of companies or LCI and LCA studies, emissions permits and general government statistics (e.g., mineral industry surveys, Bureau of Labour statistics and Energy Information Administration data).

This secondary data of industrial operations is used to develop, calculate and set-up LCI data by experienced Sphera engineers with background in the technology and capability in the field, with the support of technical reference literature or branch encyclopaedias.

Sphera engineers are in constant contact with industrial companies and associations to update their knowledge about representative process-chain details and new technologies.

Sphera's developed capabilities and critical-constructive feedback from industry confirms Sphera's approach to model real process chain circumstances. Due to this process of continuously learning about industrial operations, we consider Sphera data the best available "industry-borne" data.

Sphera's strategy is proactive cooperation with industry. In the event of an unavailability of data, confidentiality or missing access to (company or process) specific data, Sphera can bridge the gap with developed capabilities and possibilities to generate generic data of comparable quality.

Publicly available information such as internet sources, environmental reports, scientific or application reports with industry participation, other industry publication or other LCI relevant literature is constantly screened and used for benchmark purposes. The quality of technical data of many publications varies considerably. The sole fact that the information is officially published or publicly available ensures neither the consistency nor quality of the content. The professional user of publicly available data should either know and trust the source, or be able to judge and ensure the quality.

All generic GaBi data seeks to directly involve feedback of users, companies and associations by validation or benchmarks with various industry or process information. Sphera offers and maintains a constant connection with suitable users and diverse information sources from industry.

3.4.2 Unit process and aggregated data

GaBi Databases deliver unit processes, aggregated and partly aggregated data and complete life cycle (sub-) systems (plans), which include varying combinations of the aforementioned data. Any delivered dataset and system is based on suitable raw data and process chain data.

As stated in the “Global Guidance Document for LCA databases” UNEP/SETAC 2011 – to which Sphera contributed considerably with its expertise to reflect professional issues through the provision of a global software and multi-branch database - there exist many good reasons to provide and use any of the aforementioned datasets.

The main goal of GaBi data is to enable the utilisation of best available information from reliable and suitable technical sources. GaBi does not follow certain paradigms or patterns concerning data or data types. All data types are welcome, used and supported, if they are determined to be suitable.

The reliability and representativeness of the data source are important aspects to ensure the data's appropriateness and quality. The possible level of (public) disclosure of data is subject to individual circumstances, the source and the proprietary nature of the information provider. In LCA and business practise many different circumstances related to ownership, rights, patents and property exist.

In practise anti-trust and competition, regulations exist, aside from those dealing in the proprietary, which are properly maintained by GaBi database. It works to ensure conformance with related laws and regulations.

Regarding reliability and representativeness, unit process data must ensure that it technically fits within each other if used in one system. Random connection without a suitable check of technical consistency may lead to wrong results, even if unit processes are disclosed. The fact that a unit process for a certain operation exists, does not necessarily mean that it is technically suitable, up-to-date or appropriate. Background knowledge concerning the real B2B supply chains is essential.

Transparency is an important aspect. In aggregated processes, GaBi Databases ensure transparency through suitable documentation that covers all important technical facts. Parts of the Master Database are used to share more details and process chain knowledge under bilateral business relationships.

Assistance for choosing the right level of data aggregation for publishing LCI data

The following paragraph intends to help you in choosing the right level of aggregation for publishing your data, either as part of the GaBi database or in any other publication such as a paper in a scientific journal. The aim is to give an overview of the different levels of aggregation that are possible in GaBi, to keep the balance between maximum transparency on the one hand side and maximum protection of proprietary information on the other side, and to choose the one that reflects your needs. You may skip the paragraph if you do not intend to use your model outside of your institution.

Publishing LCI data means making (environmental) information available to others, outside of the project it was originally made in. And with the multitude of possible goal & scope situations in LCA studies, this means also that possible users of the data shall be enabled to find out if the data is fit for their intended use. Documentation is obviously the key here. But apart from “classical” documentation using the documentation tab of a GaBi process, also the way the model is built up and published is of importance. Or, in other words, the aggregation level that is chosen. Typically, the data to be published consists of a foreground system that is the own work of the publisher and a background system of previously published data such as datasets from the GaBi database.

Please note that the following pictures are variants of the same system and give the same results.

- a) A value chain of “unit process, single operation” (u-so) – full unit process transparency, full separation of foreground and background system

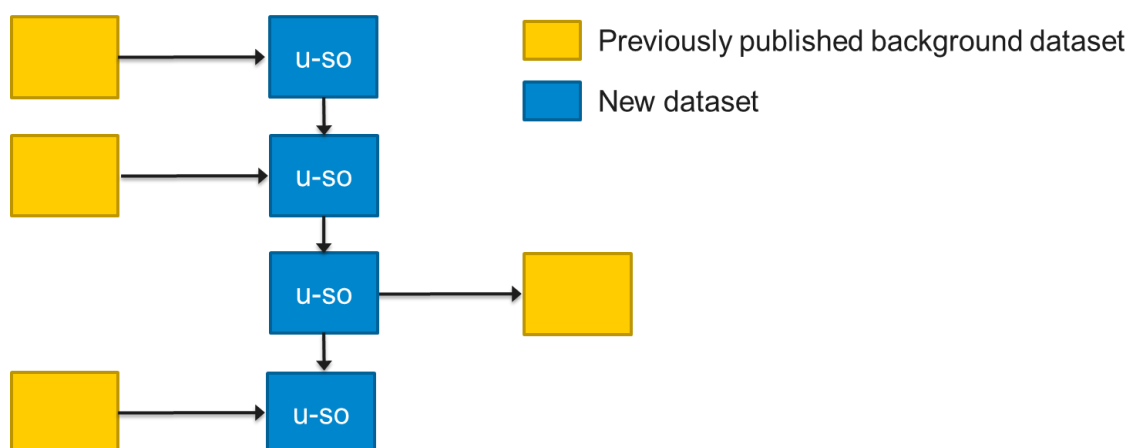

- b) Black box unit processes (u-bb) – parts or even all parts of the foreground system are aggregated into a single process step (the black box) but fully separated from the background system

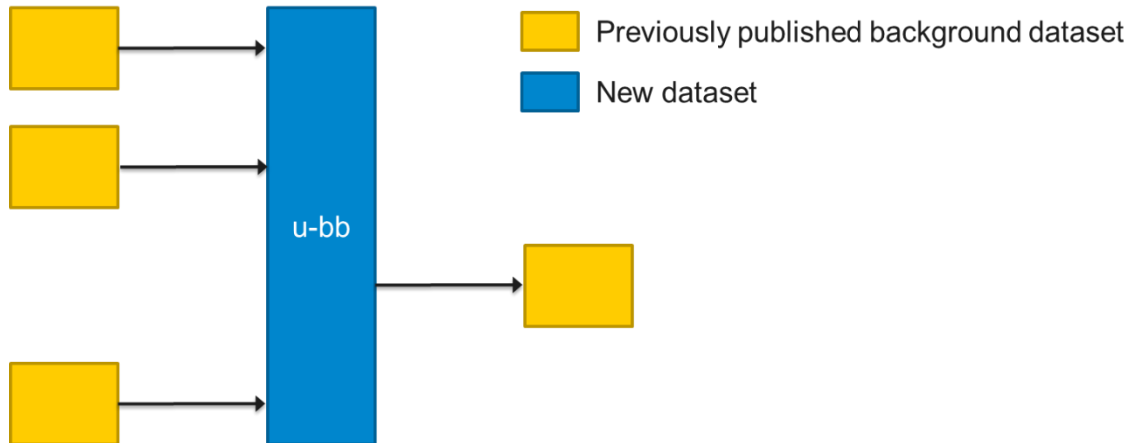

- c) Partly aggregated process (p-agg; also termed Partly-terminated systems”) – single parts of the background system are separated, other parts of the background system are aggregated with the foreground system

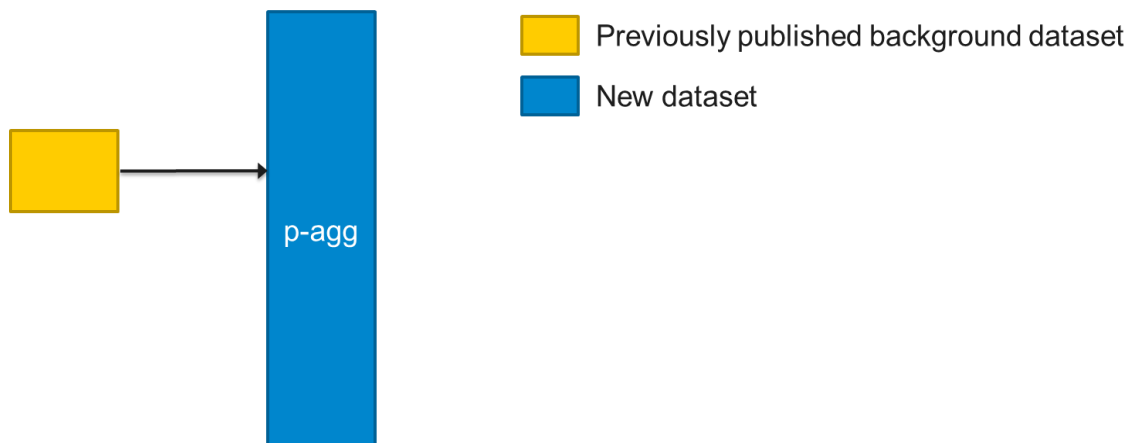

- d) Aggregated process (agg; also termed LCI results) – full privacy, foreground and background system together form a black box

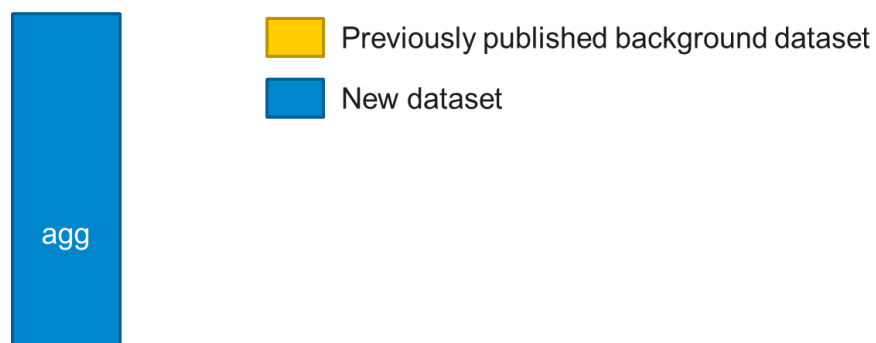

The following criteria need to be evaluated when choosing a level of aggregation:

- **Transparency.** Does the aggregation level allow the practitioner to choose the right data set?
- **Adaptability** to different contexts \leftrightarrow Protection against misuse in a different context. Do you want to allow a user of your data to e.g., change input materials or switch the background system to another country? Is it technically possible to do these changes or does this lead to technically wrong systems and results? Is the data valuable for the practitioner because it is representative for a technology/region/time or is it valuable because it can be adapted to the specific needs of the practitioner?
- **Reproducibility.** Will the practitioner get the results the publisher intends?
- **Reviewability.** Does the aggregation level allow a public critical reviewer/the practitioner to perform plausibility checks? E.g. mass balances, checks whether specific emissions are included or not, checks whether emission limits are met... Note: critical reviewers may be given access to other levels of aggregation, under non-disclosure agreements.
- **Authority.** Does the aggregation level allow the separation of the background system from the foreground system over which the publisher has full authority? Does the publisher want to answer questions about the background system?
- **Maintainability.** If a part of the background system is updated or an error in the background system was removed, shall the data reflect these changes?
- **Privacy.** Does the aggregation level protect confidential or otherwise proprietary information?

In conclusion, and well suitable for many cases, please consider this paragraph as an invitation to publish unit process black box data. Moreover, in GaBi you have the possibility to publish your process not only as a process itself but also as part of a system, using your foreground process together with GaBi background datasets on a plan. The plan will be locked, so that it is protected against unintentional changes and all users get the same results. At the same time, a user that wants to adapt the model to his/her needs can make a copy of the plan and change this copy. It is then no longer the same database object, and this can be checked in cases of doubt. This way you can separate the foreground from the background system, increase adaptability, reviewability, authority and maintainability but you can also make sure that the overall results are authentic and reproducible.

3.4.3 Units

All data should be presented in metric (SI) units. When conversions are required from imperial or non-SI units, the conversion factor must be clearly stated and documented.

3.4.4 LCI data and supported LCIA methods

It is important to clearly define the kind of data that will be covered by creating an LCI dataset for a system.

The GaBi LCI datasets are generally full-range LCI datasets. These datasets seek to cover all LCI data information, which are of environmental relevance in relation to LCA best practise.

The sum of input and output (like resources and emissions) are a compendium of 30 years of LCA work in industrial practise and the harmonised sum of all LCI interventions which could be measured, calculated or documented in LCA practice.

Important impact methodologies have influenced the flow list – and hence the data collection – seeing as GaBi considers the relevant impact categories and evaluation methods.

Basing the work on a harmonised and constantly growing flow list provides consistency among different datasets provided by different groups or branches. A list of the supported impact categories including a brief description is given as a supplement.

The GaBi database delivers full-range LCIs, which enables the use of any (existing and future) impact methods for which corresponding characterization factors exist. For the following impact assessment methods GaBi delivers already implemented default values.

Complete methodologies

- CML 2001, ver. 2016 [CML 2001], additionally ver. 2001-2013
- ReCiPe 2016 v1.1, Mid- and Endpoints (I+H+E) [RECIPE 2012], additionally ver.1.05 ver.1.07 (H) and 1.08 (H)
- TRACI 2.1 [TRACI 2012], additionally TRACI 1 and TRACI 2.0
- UBP 2013 [UBP 2013], additionally UBP 1998 and UBP 2006
- EDIP 2003 [HAUSCHILD 2003], additionally EDIP 1997
- Ecoindicator 99 [ECO-INDICATOR 99 2000] and 95 [ECO-INDICATOR 95 2000]
- Impact 2002+ [IMPACT 2002]
- Environmental Footprint 2.0 (EF 2.0): Compilation, using LCIA metrics/methods of the baseline model of 100 years of IPCC 2013 [IPCC 2013], World Meteorological Organisation [WMO 2014], ReCiPe [RECIPE 2016], USETox [FANTKE 2016], Soil quality index based on LANCA [BOS ET AL. 2016], Accumulated Exceedance [SEPPALA 2006], UN Environment [FANTKE 2016 and UNEP/SETAC 2016], Ionizing Radiation (PFISTER ET AL. 2009), Resource use [CML] (ultimate reserve and MJ fossil energy [CML 2001]), and AWARE [AWARE], LOTOS-EUROS model [VAN ZELM ET AL. 2008] as implemented in ReCiPe 2008 and CML 2002 [GUINÉE ET AL. 2002 and VAN OERS ET AL. 2002].
- Environmental Footprint 3.0 (EF 3.0): Compilation, using LCIA metrics/methods of baseline model of 100 years of the IPCC (based on [IPCC 2013]), World Meteorological Organisation [WMO 2014], USETox 2.1 [FANTKE 2017] recalculated by [SAOUTER

2018], SAOUTER 2018 Soil quality index based on LANCA [BOS ET AL. 2016 and DE LAURENTIIS ET AL. 2019], Accumulated Exceedance [SEPPALA 2006 and POSCH 2008], EUROTREND model [STRUIJS ET AL. 2009], PM method recommended by UNEP [UNEP/SETAC 2016], Ionizing Radiation (PFISTER ET AL. 2009), Resource use [CML] (ultimate reserve and MJ fossil energy [CML 2001]), and AWARE [AWARE], Human health effect model as developed by [DREICER ET AL. 1995], LOTOS-EUROS model [VAN ZELM ET AL. 2008] as implemented in ReCiPe 2008 and CML 2002 [GUINÉE ET AL. 2002 and VAN OERS ET AL. 2002].

Individual input-related methods

- Abiotic Depletion Potential (ADP), reserve base [CML 2001]
- Anthropogenic Abiotic Depletion Potential (AADP) [SCHNEIDER 2011]
- LANCA land use [BOS 2019], [BOS ET AL. 2016] and [BECK, BOS, WITTSTOCK ET AL. 2010]
- Primary energy non-renewable (entered as an additional quantity)
- Primary energy renewable (entered as an additional quantity)
- Demands on natural space (surface)
- Water consumption; Water Scarcity Index [WSI, 2009], AWARE [AWARE] and WAVE+ [BERGER ET AL. 2018]

Individual output-related methods

- USETox 2010 [USETOX 2010]
- Soil Organic Matter (SOM) [MILA I CANALS 2007]
- Accumulated Exceedance (AE) [SEPPALA 2006]
- IPCC AR5 [IPCC 2013]
- Riskpoll [RABL AND SPADARO 2004]

3.4.5 Production and consumption mix

In LCA practise, process chain networks working toward one common product contain different levels of representative situations:

- **“production mix:”** This approach focuses on the domestic production routes and technologies applied in the specific country/region and individually scaled according to the actual production volume of the respective production route. This mix is generally less dynamic.
- **“consumption mix:”** This approach focuses on the domestic production and the imports taking place. These mixes can be dynamic for certain commodities (e.g., electricity) in the specific country/region.

Figure 3-19 shows the differences between the two principle approaches. Electricity generation has been selected as an example to explain the two approaches. The electrical power available

within Country C is generated by operating different types of power plants. The fuels necessary for the operation of the power plant will be supplied by domestic resources, as well as by imports from different countries. In addition to the domestic power generation, electric power might also be imported.

The part of the Figure 3-19 which is coloured in grey represents the domestic part of the production and represents the “production mix” approach.

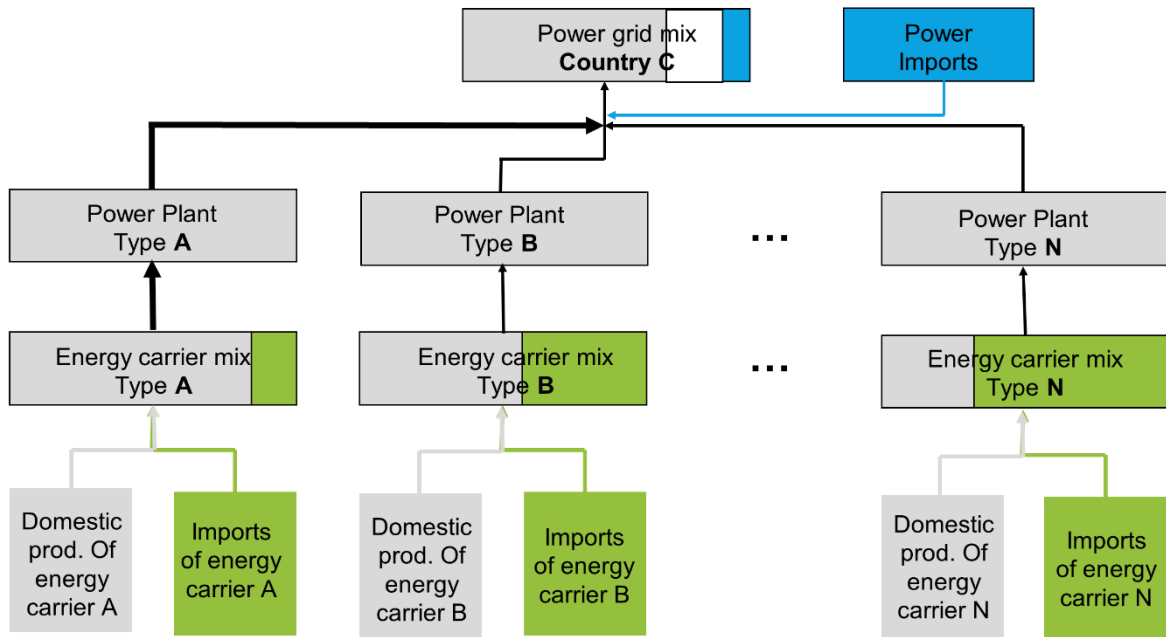

Figure 3-18: Difference between “production mix” and “consumption mix” (for power generation)

All parts of the supply chain of the power generation process coloured in green represent the imports of supplies for the power generation (imports on fuels). Imports on end energy level (imported power) are indicated in blue. The “consumption mix” includes the “production mix” as well as all imports.

The GaBi database supplies both the electricity consumption and electricity production mixes. The inclusion of the imports in the LCI data requires country-specific information about supply generation and whether final products are available or will be gathered during data collection. Not included in this example is the export as the reverse of import.

It is apparent that for every commodity contained in the database, a screening of domestic production and imports must be done, since this combination can be different for each commodity.

The GABI databases aim to provide consumption mixes wherever possible.

3.5 Data quality approach

Data quality is probably one of the most discussed issues of databases with the widest interpretation and application. Generally, data quality is discussed from two different standpoints:

- technical quality: how meaningful and representative is the given value for the defined use case
- methodological quality: how well and how consistently are procedures of certain methods addressed

For the development of the current GaBi Databases, the following method independent importance of “quality indicators” can be stated generally, see Table J.

Table J: Overview of qualitative importance of “quality indicators” in GaBi DBs

Indicator	Indication of importance					
	less					more
credibility and source of data						
access to industry information						
relation of data to technology issues						
consistency						
representativeness of data						
age/ validity of data						
transparency of documentation						
country/ region specificness						
completeness of data						
transparency of final data set						
reduction/ management data uncertainty						
uncertainty of data						
public access of raw and unit process data						

Several methods and approaches have already been proposed, but no single approach has so far been established as the “best practice.” Either the methods are based on certain amount of expert judgements or a randomly chosen certain distribution probability to produce the results. This means no method or mathematical relation can objectively produce LCA DQIs, without

certain engineering knowledge of an individual or group able to judge the quality or better consistency of the values relative to each other.

The GaBi data quality approach follows a golden rule: Be as precise and specific as needed, and as simple and applicable to all circumstances as possible. The Sphera approach is to use our experience and our relevant contacts to judge certain aspects, rather than trusting in figures that are calculated by a random procedure with little or no link to engineering reality.

As certain methodological DQI rules gain importance, these are combined with the GaBi DQI process ensuring technical and methodological quality in the most efficient and effective manner. The following paragraphs address the DQI approach in GaBi Databases.

3.5.1 Decision context

The ILCD handbook ([ILCD 2010] „specific guide“) defines 4 decision contexts for LCA projects and required LCA methods to be followed. The decision context is also relevant in PEF [PEF GUIDE 2013] and [PEF METHOD 2019], since the decision context of datasets used and results shall be stated. The definitions according to ILCD are:

Decision context A: Micro-level decision support

“Decision support, typically at the level of products, but also single process steps, sites/companies and other systems, with no or exclusively small-scale consequences in the background system or on other systems. I.e. the consequences of the analyzed decision alone are too small to overcome thresholds and trigger structural changes of installed capacity elsewhere via market mechanisms.”

Decision context B: Meso/macro-level decision support

“Decision support for strategies with large-scale consequences in the background system or other systems. The analyzed decision alone is large enough to result via market mechanisms in structural changes of installed capacity in at least one process outside the foreground system of the analyzed system.”

Decision context C: Accounting

“From a decision-making point of view, a retrospective accounting / documentation of what has happened (or will happen based on extrapolating forecasting), with no interest in any additional consequences that the analyzed system may have in the background system or on other systems. Situation C has two sub-types: C1 and C2. C1 describes an existing system but accounts for interactions it has with other systems (e.g., crediting existing avoided burdens from recycling). C2 describes an existing system in isolation without accounting for the interaction with other systems.”

Decision context C 1: Accounting, incl. interactions with other systems

“Note that any decision support that would be derived needs to employ the methods under Situation A or B, with Situation C having a preparatory role only. Note however that due to the simplified provisions of this document, the modelling of Situation A studies (micro-level decision support) is identical to that of Situation C1 studies, but not vice versa.”

Decision context C 2: Accounting, excl. interactions with other systems

The GaBi database is supporting decision context A, as it is designed for the following main applications:

- Product improvement
- Product comparisons
- Communication
- Accounting

All of these applications are listed under decision context A and C1, where A and C1 are identical (see above). This however does not mean that the use of GaBi Databases is not possible in decision context B, since in these projects not all parts of the production system under supervision are affected by large-scale consequences. In these projects, the practitioner may use the attributional GaBi datasets, identify consequential parts of the system that are typically in or close to the foreground system of the study and change these consequential parts according to the needs of the project.

3.5.2 Data Quality Indicators (DQIs)

GaBi datasets aim to be technology specific. Various technologies may produce comparable products. GaBi datasets aim to provide

- the most likely “representative” case
- if suitable, a range of different technologies for the same product
- if suitable, the local consumption (or market) mix based on capacities

Where distinctly different technology pathways are used to produce the same materials/products/commodities, they are kept separate and the local consumption (or market) mix is additionally provided. Below are some examples of important technology differences:

- Electricity from different power plants (CHP, coal or gas, hydro, or wind)
- Steel making: electric arc, basic oxygen furnace, HiSmelt technology
- Blast furnace or electro-refined metals
- Wet or dry process cement clinker production

Plain average values for the above-mentioned processes (regardless of unit process level or aggregated level) would not be representative of any of the technologies. There is also a rationale

for regional production models for commodities that are predominantly traded within a certain region.

- Electricity, gas and petroleum products
- Wood panels and timber products
- Cement, aggregates and sand
- Waste management services

For some low impact materials, transport is the dominant impact on their production and transport distances and modes may crucially affect the LCI results with sometimes counter-intuitive outcomes. For example:

- Aggregates shipped long distances by sea from coastal quarries may have lower net impacts than more local sources delivered by road.

Therefore, the GaBi Databases focus on the most relevant aspects first, after screening and identifying the most important issues of a specific life-cycle model.

With the 2013 database upgrade, Data Quality Indicators (DQIs) have been introduced for all Sphera datasets (that time in total approximately 7,200 datasets, professional DB, extension DBs, data on demand). The methodology is based on Product Environmental Footprint (PEF) requirements, further specifying the open framework set by the PEF guide [PEF GUIDE 2013].

Each dataset is reviewed by two Sphera experts:

- One industry sector specific LCA expert
- One database expert ensuring overall consistency

The following chapters discuss the six quality indicators, the overall data quality indicator and the method for data quality assessment via expert judgement.

3.5.2.1 Technical Representativeness

Information about data representativeness is assessed qualitatively and reflects the extent to which the dataset represents the reality of a certain process or process chain, e.g., completely, partly or not representative. GaBi data aims for best technological representativeness from the point of commission back to the resource extraction. Technology really does matter.

For the DQIs, the datasets are expert judged using the instance properties of the processes and plans of the system with an emphasis on unit processes and the main precursor materials/energies. The following settings are used:

- **Very good¹³:** Completely representative – Technology mix or solely existing technology in the market regarding unit process and related main precursors (energy and materials)
- **Good:** Completely / partly – Main technology in the market AND precursors from the main technology of the market
- **Fair:** Partly representative – one of the relevant technologies in the market and precursors from the main technology of the market OR main technology of the market and precursors from one of the relevant technologies in the market
- **Poor:** Partly / not – one of the existing technologies and precursors from one of the existing technologies in the market
- **Very poor:** Not representative – one of the existing technologies that is known to be not representative

3.5.2.2 Geographical representativeness

The GaBi Databases have a 4-layer regionalisation approach.

- Transferring existing technology information into other countries by adapting the energy supply
- Adapting the important upstream processes with regional supply data
- Collecting information of the technology mix used in the region to adapt the existing information
- Collecting and validating primary data in the regional industry networks

Inventory data that shows the necessary geographical representativeness for the foreground data, site or producer/provider specific data for the foreground system, supplier-specific data is used for the products that connect the foreground with the background system. Generic data of geographical mixes can be used also in parts of the foreground system if it is justified for the given case to be more accurate, and complete than available specific data (e.g., for processes operated at suppliers). For the background system, average market consumption mix data can be used.

For the DQIs, the datasets are reviewed by expert judgement using the settings of the instance properties of the processes and plans of the system with an emphasis on the unit process and the main precursor materials/energies. Four criteria are used:

¹³ **Important: We note that the European Commission's Environmental footprint uses a more positive labelling of the quality levels, i.e. what is „Very good“ in GaBi is „Excellent“ in EF. „Good“ becomes „Very good“ and so on, with „very poor“ not having an equivalent in the EF, i.e. both have 5 levels. That means – while considering differences also in the definitions of the levels – the data quality as documented in GaBi has to be interpreted to be in fact one full level higher in the EF terminology.**

- Technology representative for the region/country stated?
- Precursor materials representative for the region/country stated?
- Precursor energies representative for the region/country stated?
- “Mix and location type” represents the one stated in the documentation?

The following settings are used:

- **Very good:** Completely representative – all 4 criteria met
- **Good:** Completely /partly representative – 3 out of 4 criteria met
- **Fair:** Partly representative – 2 out of 4 criteria met
- **Poor:** Partly / not representative – 1 out of 4 criteria met
- **Very poor:** Not representative – unit process and main precursors representing another geography than the area stated and are known to be not representative

3.5.2.3 Time-related representativeness

The time-related representativeness indicates a reasonable reference value for the validity of the dataset. That means for unit processes the dataset is most representative for the indicated year. This year is neither the year of the most recent source that is used nor the year of the oldest. The time at which the data collection occurred should be used as a reference.

In GaBi the ‘most representative’ year indicates the current year of the modelling or validity checking of the data, if Sphera engineers did not have any evidence that something changed or developed in process technology concerning this production step.

For the DQIs, the datasets are reviewed by expert judgement using the settings of the instance properties of the processes and plans of the system with an emphasis on the unit process and the main precursor materials/energies. The following settings are used:

- **Very good¹³:** Completely representative – Check of representativeness or main data source not older than 3 years
- **Good:** Completely /partly representative
- **Fair:** Partly representative – Check of representativeness or main data source not older than 3 years, known changes but still partly representative
- **Poor:** Partly / not representative
- **Very poor:** Not representative – technology that is known to be not representative

3.5.2.4 Completeness

Completeness provides information regarding the percentage of flows that are measured, estimated or recorded, as well as unreported emissions. In the GaBi Databases, the following procedure is adopted:

- **“all flows recorded”**: The entire process is covered by complete access to process data or the process was modelled in a very detailed form. Processes in which the cut-off rules were applied and checked can also be considered complete.
- **“all relevant flows recorded”**: The relevant flows of the process are covered. When not all flows can be recorded, this is the next option, which still enables good quality of results in terms of evaluation.
- **“individual relevant flows recorded “**: Only particular flows are recorded. It must be clear that in this case some important flows can have been omitted, so only medium quality of data can be achieved. If possible, further research should be performed.
- **“some relevant flows not recorded”**: If good quality is desired, this case should not occur. In the case that no data is available, reasons for using this kind of data should be documented.

The technical, geographical and time related-representativeness of the background process is also stated in the documentation and the process name. Aside from the description of the underlying background data, the proper application of the data by the user (goal and scope dependent) and its respective documentation is also important. GaBi offers several possibilities to document the proper application of the background data in user-specific cases. This can be done on the plan-system level in GaBi, by indicating the technical, geographical and time-related representativeness.

For the DQIs, the datasets are reviewed by expert judgement using the settings described above:

- **Very good**: all flows recorded
- **Good**: all relevant flows recorded
- **Fair**: Individual relevant flows recorded
- **Poor**: some relevant flows not recorded
- **Very poor**: no statement about completeness available

3.5.2.5 Consistency

Consistency refers to the uniformity of the data, methodology and procedure used in the data set-up and database maintenance and additions. The GaBi database is consistent since all datasets follow the same methodology and principles as described in this document. The Sphera

database content uses consistent data sources and background systems (e.g., transport, energy processes).

For the DQIs, the datasets are reviewed by expert judgement using the following settings:

- **Very good:** defined methodology or standard, certified conformance
- **Good:** GaBi Modelling Principles
- **Fair:** ISO 14.040 with additional method/consistency requirements mainly met
- **Poor:** ISO 14.040 with additional method/consistency requirements partly met
- **Very poor:** Methodology or consistency with known deficits

3.5.2.6 Uncertainty / Precision

Precision determines the probability distribution of data, and whether it has been measured, calculated or estimated. In the case of the GABI databases, the following procedure is adopted regarding the origin:

- **Measured:** Values measured directly by the LCA practitioner, producer or project partner. Values from reports, which were measured and allowed to be published, can be also considered as measured.
- **Literature:** Values obtained from literature which does not explicitly state, whether the value was measured or estimated.
- **Calculated:** The values were calculated, e.g., stoichiometric.
- **Estimated:** Expert judgement, e.g., referring to comparable products/processes or legislations.

Origin / reliability are not part of the 6 DQIs used by ILCD/PEF. But whether data is plausibility checked by an expert or not is an important fact concerning the precision and deserves to be part of the assessment process.

For this semi-DQI, the datasets are reviewed by expert judgement using the following settings:

- **Very good¹³:** measured /calculated AND verified
- **Good:** measured / calculated / literature and plausibility checked by expert
- **Fair:** measured / calculated / literature and plausibility not checked by expert OR Qualified estimate based on calculations plausibility checked by expert
- **Poor:** Qualified estimate based on calculations, plausibility not checked by expert
- **Very poor:** Rough estimate with known deficits, not based on calculations

Uncertainty in the LCA is often discussed from two different viewpoints: There is a scientific discussion on one side, as to which approach is the best to calculate something rather uncountable¹⁴.

And there is a discussion about practise, dealing with how to limit uncertainty of results and how to judge its importance regarding stability of results and proper decision support.

In GaBi database work, Sphera chooses the following approach to minimise uncertainty:

- 1) Completing correct data collection (and close mass and energy balances).
- 2) Choosing representative LCA data for the upstream and background data, which represent the actual technology
- 3) Understanding the technical processes and defining parameters that are uncertain
- 4) Completeness of the system (no unjustified cut-offs)
- 5) Consistent background data

Consistent data collection and background data are the basis to reducing uncertainty. In addition, useful scenarios, sensitivity calculations and technical understanding of the LCA modeller (as well as the reviewer) ensure minimum uncertainty.

If the LCA modeller and the reviewer have no indication how the identified technical parameters may perform while they do need to know how the parameters are formally or stochastically related, Monte Carlo Analysis is an alternative. It allows the examination of consequences of random uncertainties of known probability distribution for some selected technical parameters. The quality of the resulting “uncertainty statements” strongly depend on the selection of these technical parameters, which should be as representative (in terms of uncertainty) as possible. More importantly, Monte Carlo requires that the parameters are orthogonal, i.e., independent. As the amounts of the inputs and outputs of processes are however mechanistically linked (e.g., the amount of aluminium that goes in, is the sum of co-products and waste that comes out), or are stochastically linked (e.g., correlated emissions), this key requirement for a meaningful Monte-Carlo-Simulation is not met in LCA. The effect of ignoring such dependencies are hugely underestimated uncertainties, rendering the exercise worthless. To nevertheless yield meaningful Monte Carlo Simulation results, it is however possible and sufficient to adjust the parametrisation of the model’s most relevant parameters to yield independent parameters and include only those in the Monte Carlo Simulation (see WOLF&EYERER 2002).

Further challenges in this context are: broad methodological acceptance, availability of uncertainty information for all model parameters, availability of quantitative information about

¹⁴ “Not everything that can be counted counts and not everything that counts can be counted”. Albert Einstein

the mechanistical and stochastic (cor)relation of the values and parameters among each other, and implementation effort. Luckily, most values in a model do not contribute relevantly to the results and hence to the uncertainty. Via a preceding contribution analysis or parameter variation, those most influential parameters can be identified to be adjusted and included in the Monte Carlo Simulation. Still, the very high effort for the model adjustment and also the lack of underlying uncertainty data for the individual parameters practically prevent the broad application of meaningful Monte Carlo Simulation across whole databases.

Based on the above discussion, a more practical approach to quantify the uncertainty issue was developed for the GaBi background database.

Quantifying uncertainty in GaBi

Uncertainty in LCA can be split into two parts:

- data uncertainty (the uncertainty of the modelled, measured, calculated, estimated) and data within each unit process
- model uncertainty (uncertainty introduced in the results of a life cycle inventory analysis due to the cumulative effects of model imprecision, input uncertainty and data variability)

Uncertainty in LCA is usually related to measurement error-determination of the relevant data, e.g., consumption or emission figures. Since the 'true' values (especially for background data) are often unknown, it is virtually impossible to avoid more or less uncertain data in LCA. These uncertainties then propagate through the model and appear in the final result. Small uncertainties in input data may have a large effect on the overall results, while others will diminish along the way. The next paragraph addresses Sphera's recommendations for addressing the quantification of uncertainty in an LCA study, and how it can be done practically and with reasonable accuracy.

Quantifying the uncertainty of primary data points on company-specific processes can be relatively straightforward and easy for a company to calculate using the mean value and its standard deviation over a certain number of data points.

But quantifying the uncertainty in the background systems (hundreds of upstream processes including mining and extraction) and then performing error propagation calculation is typically neither practical nor feasible due to the cost and time constraints in an industrial setting. In addition to put the issue in a general perspective, one should be wary of data with an extremely precise uncertainty value to each inventory flow, as these cannot be calculated with the accuracy that the value implies.

A common rule estimates that the best achievable uncertainty in LCA to be around 10%. This was supported by [KUPFER 2005] on the example of the forecast of environmental impacts in

the design of chemical equipment. The actual degree of uncertainty can vary significantly from study to study.

The overarching question that really must be answered is:

How robust is my overall result when taking into account the combined uncertainties?

The effort to come up with a reasonable estimate can be significantly reduced by following a two-step approach:

Understand the model structure and its dependencies

Keep it simple at first and start by setting up your model with values you have. Then **try to develop an understanding of the most relevant aspects of your LCA model**, i.e., those life cycle phases, contributors, or data points that have the largest impact on your result. This is usually done by a **contribution or 'hot spot' analysis** and a subsequent **sensitivity analysis**. Both of these functions are available to GaBi users in the LCA balance sheet through the Weak Point Analysis and the GaBi Analyst

Here is an example: The contribution or 'hot spot' analysis of an energy-using product may show that the use phase is dominating the life cycle greenhouse gas emissions, closely followed by the production of a printed circuit board and logistics. Sensitivity analyses may then show that the parameters that influence these contributors the most are the split between online and stand-by mode during use, the amount of precious metals in the circuit board and the distance from the Asian production facility to the local distribution centre. This example also shows that a further step is needed: the influencability of the most relevant factors: the distance from manufacturing in e.g. China to the market is typically not/hardly influencable,

1) Test the robustness of the model's results

The next step is to focus efforts on estimating the level of uncertainty of each of the identified key parameters. Do some more research to establish **upper and lower bounds** for the relevant parameters. The higher the uncertainty, the larger these intervals will be. It may even be possible to find data that allows for the **calculation of a standard deviation** in literature.

The combined effect of these uncertainties can then be assessed using the **Monte-Carlo simulation** available in the GaBi Analyst. By defining uncertainty intervals around the key parameters, the Monte Carlo simulation is able to **produce a statistical estimate (mean value) of the end result (e.g., X kg of CO₂ equivalents) as well as its standard deviation** across all simulation runs. To do this it simply draws random numbers from the defined intervals and calculates a single result using that set of numbers. By repeating this procedure, a multitude of times (1,000 up to 10,000 runs is usually a good number), it will produce a probability distribution of 1,000 to 10,000 individual results. **The lower the standard deviation associated with it, the more robust or 'certain' your result is.** The resulting mean value is also closer to the

‘real’ value than the value obtained when doing a simple balance calculation based on the basic parameter settings. We reiterate that Monte-Carlo Simulation necessitates to select independent parameters or to adjust the model to make them independent, as explained in a previous chapter. Without this, Monte-Carlo results are simply meaningless.

To make the assessment more robust towards any additional, unknown uncertainties, it is possible to **increase the ascertained intervals** around the key parameters by a specific ‘**safety factor.**’ This will provide a sound estimate of the robustness of the model.

For more quantified results on uncertainty issues in LCA, see Supplement B.

Coefficients of variation

As seen in the above discussion and from quantified results in Supplement B, the percentage maximum error can easily reach several orders of magnitude for the ‘chosen max’ cases. These numbers can be misleading, though, since they heavily depend on the magnitude of the respective denominator, i.e., the minimum values. A more unbiased way to look at the variability across the evaluated datasets is to calculate the **coefficients of variation** across the absolute indicator results, which is defined as the **standard deviation divided by the modulus of the mean value**. When the modulus is used, the coefficient is always a positive value.

The following table displays the maximum coefficients of variation across datasets for each impact category separately. Again, **knowing the country of origin but not knowing the specific technology route can be worse** than the inverse case. The coefficients of variation are significantly higher for the latter case.

Table K: Coefficients of variation, from a case study

Impact	known technology / unknown country of origin	unknown technology / known country of origin
PED	32%	88%
AP	92%	98%
EP	63%	123%
GWP	47%	89%
POCP	86%	132%

This chapter answered two questions: First, how do I assess the uncertainty of my LCA model in GaBi? And second, how large are the uncertainties across different datasets assuming that either the country of origin or the technology route is not known?

While it is known from experience, as well as a recent PhD thesis, that the model uncertainty can rarely be kept below 10%, once the most appropriate datasets have been chosen, the uncertainty around this choice can be significantly higher. For most considered datasets, the relative error

is between -75% and +250%, while the coefficient of variation is roughly between 90% and 130%.

Based on these results, the following conclusions can be made:

- 1) The appropriate choice for dataset is a higher concern for the uncertainty on the elementary flow level. The selection of the most representative technology route has a large influence on the resulting environmental profile. The most 'certain' dataset can introduce a massive error to your model if it is not representative to the process / product at hand.
- 2) When the most representative datasets have been identified and deployed, the next concern is about the accuracy of your model structure and parameter settings. Here the described functionalities of the GaBi Analyst can help you understand the dependencies and assess the overall effect on your results.

Knowing about the difficulties of quantification of precision and also knowing that all of the other elements of data quality (technology, time, geography, completeness, methodological consistency, data origin) have an influence on precision, Sphera decided to **calculate the arithmetic average out of the six criteria above (5 other DQIs plus Origin), but the result cannot be better than completeness.**

This follows the logic of PEF [PEF GUIDE 2013] (where the values given for precision are 100% minus the values for completeness) and also follows the logic of data that has a normal distribution, since for these the expected values and the standard deviations may simply be combined and form another normal distribution (addition theorem of normal distribution). Sphera knows about the deficit this procedure has for low quality data (estimations), where one poor or very poor element of data quality (e.g., technological representativeness, see above) can spoil the precision regardless of the values of the other elements. But on the other hand the number of low quality datasets in the GaBi Databases is very low and the experts reviewing the data quality in such cases are asked to be extremely critical regarding the other elements, which leads to the fact that datasets with known deficits ("poor" in any of the elements) do not have a precision better than "fair" in the GaBi database.

3.5.2.7 Overall Quality

The overall quality of the datasets depends on the values of the 6 DQIs described above. Sphera has decided to calculate the average value from the 6 DQIs and use it for the overall quality. There are however other possibilities according to ILCD [ILCD 2010] and PEF [PEF GUIDE 2013] and [PEF METHOD 2019] (same rules for OEF). The methods used in these two assessment schemes are illustrated in Figure 3-20 and Figure 3-21. In the documentation of the datasets,

all three methods are used to give the practitioner an overview of the usability of the datasets in ILCD and PEF/OEF.¹⁵

The outcome of the overall data quality of the GaBi Databases is:

- 99% of the datasets are usable in ILCD/EF related projects, both as being LCD DN entry-level compliant and regarding the minimum require data quality.
- **95% of the datasets achieved an overall GOOD data quality and are usable in PEF/OEF studies without any restrictions.**
- 4% of the datasets achieved an overall FAIR data quality and are usable in PEF/OEF studies, but better data should be sought and used.
- 1% of the datasets achieved an overall POOR data quality and are not currently usable in PEF/OEF studies.

The overall data quality shall be calculated as detailed in Formula 3:

$$\text{Formula 3} \quad DQR = \frac{TeR + GR + TiR + C + P + M + X_w * 4}{i + 4}$$

- *DQR* : Data Quality Rating of the LCI data set; see Table 7
- *TeR, GR, TiR, C, P, M* : see Table 5
- *Xw* : weakest quality level obtained (i.e. highest numeric value) among the data quality indicators
- *i* : number of applicable (i.e. not equal "0") data quality indicators

Table 7 Overall quality level of a data set according to the achieved overall data quality rating

Overall data quality rating (DQR)	Overall data quality level
$\leq 1.6^{77}$	"High quality"
$>1.6 \text{ to } \leq 3$	"Basic quality"
$>3 \text{ to } \leq 4$	"Data estimate"

¹⁵ Note that PEF and OEF studies on those product groups and organisation types for which an official PEFCR or OEFSR has been developed, may only use the prescribed EF secondary datasets. Sphera has won 7 of the 13 data tenders under the EF pilot phase and provided those data sets as EF 2.0, based on GaBi data. Sphera also provides the commonly to-be-used energy-transport-packaging-EoL data packages for the transition phase as EF 3.0, with other data projects yet outstanding.

Figure 3-19: Overall data quality according to ILCD assessment scheme [ILCD 2011]. This follows partly a more robust “weakest link in the chain” logic, that the poorest data aspect downgrades the overall quality (as it has a higher weight assigned).

$$\text{Formula 1} \quad \text{DQR} = \frac{\text{TeR} + \text{GR} + \text{TiR} + \text{C} + \text{P} + \text{M}}{6}$$

- DQR: Data Quality Rating of the dataset
- TeR: Technological Representativeness
- GR: Geographical Representativeness
- TiR: Time-related Representativeness
- C: Completeness
- P: Precision/uncertainty
- M: Methodological Appropriateness and Consistency

Table 6

Overall data quality level according to the achieved data quality rating

Overall data quality rating (DQR)	Overall data quality level
≤ 1,6	"Excellent quality"
1,6 to 2,0	"Very good quality"
2,0 to 3,0	"Good quality"
3 to 4,0	"Fair quality"
> 4	"Poor quality"

Figure 3-20: Overall data quality according to EF assessment scheme [PEF guide 2013]

3.5.2.8 Overview of the DQIs

	1	2	3	4	5	Assistance to reviewer
Very good Completely representative - Technology mix or solely existing technology of the market regarding unit process and related main precursors (Energy and materials)	Good Completely / partly - Main technology of the market AND precursors from the main technology of the market	Fair Partly representative - one of the relevant technologies of the market and precursors from the main technology of the market OR main technology of the market and precursors from one of the relevant technology of the market	Poor Partly / not - one of the existing technologies and precursors from one of the existing technologies of the market	Very poor / not evaluated / unknown Not representative - one of the existing technologies that is known to be not representative		Settings of the instance properties of the processes and plans of the system. To be reviewed by expert judgement with an emphasis to the unit process and the main precursor materials/energies
Technological representativeness						
Time representativeness	Completely representative - Check of representativeness or main data source not older than 3 a	Completely /partly representative	Partly representative - Check of representativeness or main data source not older than 3 a, known changes but still partly representative	Partly / not representative	Not representative - technology that is known to be not representative	Settings of the instance properties of the processes and plans of the system. To be reviewed by expert judgement with an emphasis to the unit process and the main precursor materials/energies
Geographical representativeness	Completely representative - all 4 criteria met	Completely /partly representative - 3 out of 4 criteria met	Partly representative - 2 out of 4 criteria met	Partly / not representative - 1 out of 4 criteria met	Not representative - unit process and main precursors representing another geography than the area stated and is known to be not representative	representative # precursor energies representative # "Mix and location type" represents the one stated in the documentation. Settings of the instance properties of the processes and plans of the system. To be reviewed by expert judgement with an emphasis to the unit process and the main precursor materials/energies
Completeness	All flows captured	All relevant flows recorded	Individual relevant flows recorded	Some relevant flows not recorded	No statement	Setting of the agg dataset as published
Methodological appropriateness and consistency	defined methodology or standard, certified compliance	GaBi modelling principles	ISO 14.040 with additional method/consistency requirements mainly met	ISO 14.040 with additional method/consistency requirements partly met	Methodology or consistency with known problems	
Origin / Reliability	measured /calculated AND verified	measured / calculated / literature and plausibility checked by expert	measured / calculated / literature and plausibility not checked by expert OR Qualified estimate based on calculations plausibility checked by expert	Qualified estimate based on calculations, plausibility not checked by expert	Rough estimate with known deficits	arithmetic average out of six (5 other DQIs plus Origin), but cannot be better than completeness. This follows the logic of PEF regarding (1-completeness) and also follows the logic of data that has a normal distribution, since for these the expected values and the standard deviations simply may be combined and form another normal distribution (Additionstheorem Normalverteilung)
Precision (parameter uncertainty)						Arithmetic mean from the 6 DQIs above
Overall quality						

Figure 3-21: Overview of the six GaBi DQIs and the criteria for the assessment of datasets

Figure 3-22 gives an overview of the criteria used when assessing the data quality via expert judgement. Figure 3-23 shows a screenshot of a dependent internal review that can be found in

the documentation tab of Sphera GaBi datasets in the category validation. The value of the DQIs can be seen and the other review details gives an overview of the achieved overall data quality according to the assessment schemes of GaBi, ILCD and PEF.

Validation ⌵

Type of review	<div style="border: 1px solid #ccc; padding: 2px;">Dependent internal review</div>	<div style="border: 1px solid #ccc; padding: 2px; background-color: #f0f0f0;">Delete review</div>																				
Scope of review	<table style="width: 100%; border-collapse: collapse;"> <thead> <tr style="background-color: #e0f0e0;"> <th style="width: 30%; padding: 2px;">Scope of review</th> <th style="padding: 2px;">Method(s) of review</th> </tr> </thead> <tbody> <tr><td style="padding: 2px;">Raw data</td><td style="padding: 2px;">Validation of data sources, Sample tests on calculations, Cross-check with other source, Expert judge</td></tr> <tr><td style="padding: 2px;">Unit process(es), single operation</td><td style="padding: 2px;">Validation of data sources, Sample tests on calculations, Energy results, Element results, Cross-check</td></tr> <tr><td style="padding: 2px;">Unit process(es), black box</td><td style="padding: 2px;">Validation of data sources, Sample tests on calculations, Energy results, Element results, Cross-check</td></tr> <tr><td style="padding: 2px;">LCI results or Partly terminated system</td><td style="padding: 2px;">Validation of data sources, Sample tests on calculations, Energy results, Element results, Cross-check</td></tr> <tr><td style="padding: 2px;">LCIA results</td><td style="padding: 2px;">Cross-check with other source, Cross-check with other data set, Expert judgement</td></tr> <tr><td style="padding: 2px;">Documentation</td><td style="padding: 2px;">Expert judgement, Compliance with ISO 14040 to 14044</td></tr> <tr><td style="padding: 2px;">Life cycle inventory methods</td><td style="padding: 2px;">Compliance with ISO 14040 to 14044</td></tr> <tr><td style="padding: 2px;">LCIA results calculation</td><td style="padding: 2px;"></td></tr> <tr><td style="padding: 2px;">Goal and scope definition</td><td style="padding: 2px;"></td></tr> </tbody> </table>		Scope of review	Method(s) of review	Raw data	Validation of data sources, Sample tests on calculations, Cross-check with other source, Expert judge	Unit process(es), single operation	Validation of data sources, Sample tests on calculations, Energy results, Element results, Cross-check	Unit process(es), black box	Validation of data sources, Sample tests on calculations, Energy results, Element results, Cross-check	LCI results or Partly terminated system	Validation of data sources, Sample tests on calculations, Energy results, Element results, Cross-check	LCIA results	Cross-check with other source, Cross-check with other data set, Expert judgement	Documentation	Expert judgement, Compliance with ISO 14040 to 14044	Life cycle inventory methods	Compliance with ISO 14040 to 14044	LCIA results calculation		Goal and scope definition	
Scope of review	Method(s) of review																					
Raw data	Validation of data sources, Sample tests on calculations, Cross-check with other source, Expert judge																					
Unit process(es), single operation	Validation of data sources, Sample tests on calculations, Energy results, Element results, Cross-check																					
Unit process(es), black box	Validation of data sources, Sample tests on calculations, Energy results, Element results, Cross-check																					
LCI results or Partly terminated system	Validation of data sources, Sample tests on calculations, Energy results, Element results, Cross-check																					
LCIA results	Cross-check with other source, Cross-check with other data set, Expert judgement																					
Documentation	Expert judgement, Compliance with ISO 14040 to 14044																					
Life cycle inventory methods	Compliance with ISO 14040 to 14044																					
LCIA results calculation																						
Goal and scope definition																						
Quality indicators	<table style="width: 100%; border-collapse: collapse;"> <thead> <tr style="background-color: #e0f0e0;"> <th style="width: 60%; padding: 2px;">Quality indicators</th> <th style="padding: 2px;">Value</th> </tr> </thead> <tbody> <tr><td style="padding: 2px;">Technological representativeness</td><td style="padding: 2px;">Very good</td></tr> <tr><td style="padding: 2px;">Time representativeness</td><td style="padding: 2px;">Very good</td></tr> <tr><td style="padding: 2px;">Geographical representativeness</td><td style="padding: 2px;">Very good</td></tr> <tr><td style="padding: 2px;">Completeness</td><td style="padding: 2px;">Good</td></tr> <tr><td style="padding: 2px;">Precision</td><td style="padding: 2px;">Good</td></tr> <tr><td style="padding: 2px;">Methodological appropriateness and consistency</td><td style="padding: 2px;">Good</td></tr> <tr><td style="padding: 2px;">Overall quality</td><td style="padding: 2px;">Very good</td></tr> </tbody> </table>		Quality indicators	Value	Technological representativeness	Very good	Time representativeness	Very good	Geographical representativeness	Very good	Completeness	Good	Precision	Good	Methodological appropriateness and consistency	Good	Overall quality	Very good				
Quality indicators	Value																					
Technological representativeness	Very good																					
Time representativeness	Very good																					
Geographical representativeness	Very good																					
Completeness	Good																					
Precision	Good																					
Methodological appropriateness and consistency	Good																					
Overall quality	Very good																					
Review details	<div style="border: 1px solid #ccc; padding: 2px; min-height: 40px;"> The LCI method applied is in compliance with ISO 14040 and 14044. The documentation includes all relevant information in view of the data quality and scope of the application of the respective LCI result / data set. The dataset represents the state-of-the-art in view of the referenced functional unit. </div>																					
Reviewer name and institution	<div style="border: 1px solid #ccc; padding: 2px;"> <ul style="list-style-type: none"> thinkstep [Private company] LBP-GaBi [Governmental] IBP-GaBi [Non-governmental org.] <input type="text" value="Add"/> </div>																					
Other review details	<div style="border: 1px solid #ccc; padding: 2px;"> Overall quality according to different validation schemes GaBi = 1,5 interpreted into "very good overall quality" in the GaBi quality validation scheme ILCD = 1,7 interpreted into "basic overall quality" in the ILCD quality validation scheme PEF = 1,5 interpreted into "excellent overall quality" in the PEF quality validation scheme </div>																					

Figure 3-22: Screenshot of a dependent internal review including the DQIs

3.5.3 Reproducibility, Transparency, Data aggregation

The aggregation of datasets is often necessary and requested by users and providers of data in order to secure the privacy of confidential information. This enables the use of accurate and up-to-date information; furthermore, aggregation speeds up LCAs (lowering costs) as the handling of datasets and complete process chains becomes feasible for both experts and users.

Almost any LCI dataset is aggregated: Either on the unit process level (several production steps are aggregated towards a unit process or different unit processes producing a comparable product are aggregated into an average unit process) or on the process chain level (different subsequent processes are aggregated). For a good description of the various types of aggregation, see the UNEP/SETAC 2011 database guidance.

Some systems are characteristically complex and therefore only understandable by LCA experts and experts of the related technology. In order to make the handling for non-experts possible, some complex and often-used datasets must be aggregated in a representative and applicable way to make them suitable for use by a wider audience.

A prominent example is the aggregation of electricity mix data for a specific country; a complex background model, consisting of a large amount of processes and parameters (see Chapter 2.3 for details). The user has access to information transparency concerning the underlying model and data in the documentation. Most users have an interest in accurate data and are less interested in power plant details, so an aggregation of datasets is suitable and meaningful for a wide range of users¹⁶.

Two types of aggregation exist:

- horizontal
- vertical

The following figure describes the difference.

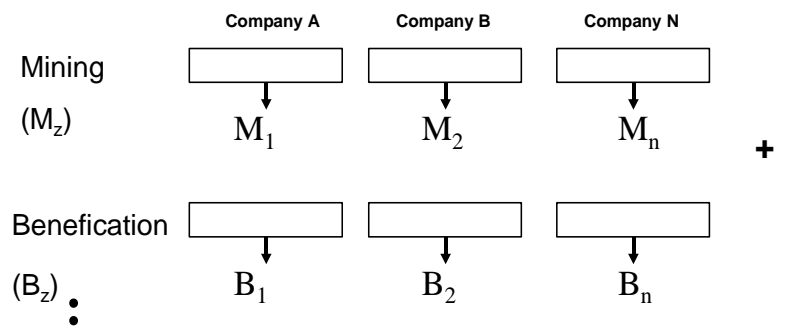

Figure 3-23: Principle graphical explanation of the relation of completeness, precision

The horizontal aggregation ($M_1 + M_2 + M_3 + \dots$) and ($B_1 + B_2 + B_3 + \dots$) is applied in the creation of a process for an average production step of a specific product by taking (different) technologies into account. The upstream or downstream processes are not integrated into this step of aggregation. The horizontal aggregation must be sure to lead to understandable and interpretable datasets, as technical information and upstream substances of different processes is aggregated and provided side by side (whilst never appearing in reality as one process). Not

¹⁶ A power plant operator or energy provider may have another view on this and wants to deal with the effects of the power plant parameters within the electricity mix. However, users that are interested in their own foreground system behaviour should rather model on basis of their specific foreground situation and should take generic background data to set up their respective background system or use it as reference or validation. Specific results on foreground systems request specific foreground data.

all unit processes of the same kind are automatically suitable for horizontal aggregation or can be subject to easy misinterpretations.

The vertical aggregation ($M1+B1+\dots$) and ($M2+B2+\dots$) is carried out by considering a specific technological route and aggregating process chain parts that exist in reality. In this case, the upstream and/ or downstream processes are included in the aggregated dataset.

Depending on the case, in GaBi Databases vertical and horizontal aggregation are applied to the datasets.

4 System Modelling Features

The GaBi software system was developed to support the complete workflow of LCA work: Starting at data collection, over life-cycle system modelling, data storage and handling, as well as interpretation.

Appropriate results call for appropriate system modelling and appropriate data. In the following chapter the technical framework of system modelling is described.

4.1 Data collection

Data collection is the basis for all following modelling steps: Analyzing the gathered data, the use of this data for the set-up of the process models and as the basis for the inventory calculation. The quality of the dataset will finally depend upon the type, sources, consistency and appropriateness of data collection. A standardised procedure is therefore defined and applied for GaBi data collections:

- Understanding the core production technique.
- Identifying the generic situation of the manufacturing of the product system to be analyzed (e.g., how many competitive producers exist, what are the applied technologies).
- Identifying the essential single process steps that are dominating the manufacturing phase of a certain product system. Ideally, this process is done in cooperation with industry, validated or accompanied by experts of the related branch.
- Creating a customised data collection sheet. Golden rule: data collection should be as detailed as necessary and as efficient as possible; staying on a realistic level, which can be supported by the data source but also fulfils LCI quality issues. A flow chart of the process helps to have a good overview and to keep track in technical discourse.
- Inspection of the returned data applying general rules which focus on consistency and quality of the gathered data, which includes:
 - Mass and energy balance
 - Emission and substance/chemical element balances
 - Plausibility check focusing the general process characteristics (energy efficiency, yield, purge streams, residues, by-products, loop substances, recovered matter)
- Provision of feedback to the data supplier or validator.

For the process of data collection different techniques can be used which differ in type, technique and effort. The following types of data collection can be used:

- 1) Manual informal (generally not used in GaBi data collection procedures)
- 2) Manual predefined formats (Word® or Excel® documents)
- 3) GaBi process recording tool
- 4) Web-based applications (e.g., GaBi web questionnaire)

Collection types 3 and 4 comfortably support the user to integrate data consistently and while saving time into GaBi.

4.1.1 Quality check and validation of collected data

During the process of data collection, our experts prepare a checklist of general points that ensure the data quality requirements are fulfilled. As previously mentioned these methods include: mass and energy balance, emission balances, plausibility check, in addition to whether all relevant processes steps and inputs and outputs are included.

If anomalies occur, problems are iteratively checked with the data provider or the data-providing expert team within Sphera. The goal would be to clarify whether it is a data or methodological problem and whether it is a special case or a common issue.

Apart from this technical check, aspects covered by the data quality issues (Chapter 3.5), data sources (Chapter 3.4) or principles such as goal (Chapter 3.2) or scope like functional unit and system boundaries (Chapter 3.3) must be checked in order to assure consistency over all data collected. All data aims to represent the reality, but the kind and detail of needed data sources can differ.

After this check, the data considered as “validated” and can be used for modelling in the GaBi framework.

4.1.2 Treatment of missing data

Missing data is a common problem of LCA practitioners (see also Chapter 3.3.5 for gap closing strategies). This can happen due to unavailability of data or missing access to data. In this case, it is up to the expert team to decide which procedure to adopt.

The goal is to find the missing data and close the gap as efficiently as possible, without unacceptable simplifications.

There is no standard rule for this problem as each case should be analyzed separately, but the following measures can be taken:

- Literature: reports, papers, books can be checked (standard way, but often no LCA suitable information available)
- For chemical reactions, often an estimation can be provided by the stoichiometry and estimation of the reaction's yield
- Estimation based on similar processes/ technologies
- Expert judgement of a skilled person (supported by one or more above aspects).

The chosen procedure for the treatment of missing data shall be documented according to the ISO 14044 [ISO 14044: 2006].

4.1.3 Transfer of data and nomenclature

The system modelling starts with the transfer of gathered data into the GaBi software system. GaBi is organised into modules. Plans, processes and flows, as well as their functions, are formed into modular units.

The fundamental basis of modelling using GaBi is the object type flow. A GaBi flow is a representative of an actual product, intermediate, material, energy, resources or emission flow.

Elementary flows are resources and emissions that are released from unit processes directly into the environment without further treatment, causing a specific environmental impact.

Intermediate flows (material or energy) are technical flows between unit processes or a product flow leaving the final process for further use in a system.

Intermediate flows are used are the link between processes within a life cycle system.

Plans (or plan systems) are used in GaBi to structure the processes in a product system. Essentially, plans are the “process maps” which visually depict a stage or sub-stage in the system and help to understand the technical reality behind the system.

A clearly defined nomenclature of flows is needed. GaBi defines all known and used flows consistently by avoiding double entries (e.g., synonyms).

A clear and defined nomenclature is needed to ease or enable data transfer with other nomenclatures and systems (like e.g., ILCD 2010). Different nomenclature systems are proposed by academia and in industrial practice. No global standard nomenclature currently exists, because theoretical and practical approaches still call for different aspects.

For each modular unit a clearly defined nomenclature is necessary to specify flows, processes and plans. In the following, the most important nomenclature aspects are listed.

Flows

- Name (most commonly used or according to existing systems)
- CAS code
- Abbreviation (e.g., polypropylene PP)
- Chemical formula (e.g., carbon dioxide CO₂)
- Technical aspects like calorific value, element content or impact category
- Reference unit (e.g., kg, MJ, Bq, Nm³)

The GaBi software system has a substantial list of consistently predefined elementary flows, so that ideally only new intermediate or product flows need to be created (look for synonyms before creating new elementary flows).

Processes

- Specification of the country
- Name (mostly the name of the product created which is also the functional unit of the process analyzed)
- Addition to the name (e.g., polyamide 6 granulate (PA 6))
- Production technology (if several technologies exist to produce the material)
- Reference year
- Data quality and completeness

Plans

The name of the plan system should enable to understand its related system boundaries, the core technology route and the core location of the operation.

Goal is a consistent naming of the flow, the related process and the related system plan.

GaBi Databases [GABI] have already integrated elementary and product flows for all datasets and the respective used flows are documented directly in the process headline.

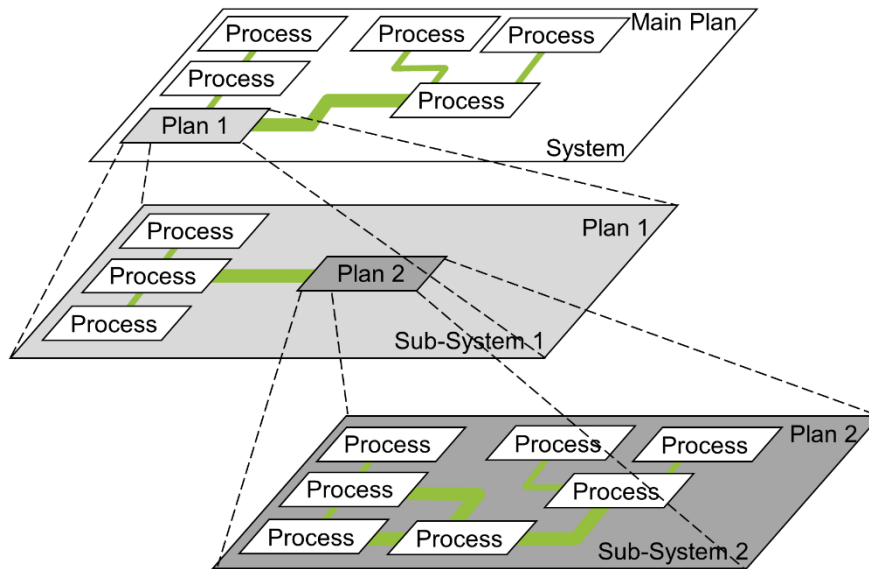

Figure 4-1: Hierarchical structure of the processes and plans

Since the efficient and flexible combination of processes and plans in GaBi affect the appropriate result analysis, a certain structure of the desired system should be known beforehand. The processes and plans can be individually structured (shown in the figure above) to represent any desired degree of detail.

4.2 Geographical aspects of modelling

To set data in the correct regional context is an important aspect of LCI modelling. Users in multinational companies, as well as national and international programs and requirements, call for realistic geographical representation. Realistic regionalisation is as dynamic as markets. The core issue of regionalisation is not the methodological approach, but rather the necessary background information on technology and the market situation.

Country-specific energy (pre-) chains are called for throughout the database (electricity, thermal energy, resources). The most relevant industry processes, including the technology route, in the respective region must be country or region-specific. If use phase or utilisation (losses or other performance issues) data are relevant, a country-specific situation is necessary. Recycling rates and waste (water) treatments may be adopted, as well as the crediting of materials and energies in EOL.

In GaBi database work and “data on demand” business, a “4 level regionalization approach” is used, which depends on the goal and scope of the data and the relevance of the related measure on the overall result.

- 1) Transferring existing technology information into other country by adapting the energy supply
- 2) Adapting the important upstream processes with regional supply data

- 3) Collecting regional technology (mix) information to adapt existing information
- 4) Collecting and/or validating primary data in the regional industry networks

If a GaBi dataset is country-specific, at least level 2 is applied. For individual information, please consult the respective documentation.

4.3 Parameter

Parameters are variables within a dataset, which allow the variation of process input and output flows to detach from a strict relationship between input and output flows (scaling). Parameters can therefore be used to calculate flow quantities (e.g., due to the characteristics of a used substance) based on technical conditions, such as efficiency of power plant using energy carrier properties or sulphur dioxide emissions depending on the sulphur content of the used fuel or other parameters.

A typical application of parameterised models (processes) is the modelling of transportation processes. It is possible to calculate the CO₂ emissions by means of a mathematical relation depending on the travelled distance, the utilisation ratio and the specific fuel consumption of a truck (see Chapter 3.3.7).

Important parameterised (background) processes are:

- crude oil, natural gas and coal extraction
- power plants
- refinery operations
- water supply
- wastewater treatment, recycling and incineration processes
- transports
- agricultural processes
- certain metal beneficiation and refining processes

Suitable parameterisation can reduce the error probability seeing as one individual (quality-checked) process can be applied in many generic situations.

4.4 Multifunctionality and allocation principle

GaBi Modelling Principles follow the ISO 14040 series concerning multifunctionality.

Subdivision for black box unit processes to avoid allocation is often possible but not always [ILCD 2010]. Subdivision is therefore always the first choice and applied in GaBi database work. This includes the use of the by-products in the same system (looping).

System expansion (including substitution) is applied in GaBi database work, wherever suitable. The system boundaries are the key issue. ISO says: “Expanding the product system to include

the additional functions related to the co-products, taking into account the requirements of appropriate system boundaries [ISO 14044: 2006].

It is to carefully check, if the function of the system would be enlarged inappropriately. If this is the case and the explicit and unique function of the dataset is not clear anymore, the system expansion should not be applied.

In practise, system expansion can lead to the need for further system expansion because the additional systems are often multifunctional. In other cases, the alternative processes exist only in theory or are of no quantitative relevance in practise. Another challenge is to identify the superseded processes, which will prove to be complex [ILCD 2010].

The aspects of a (virtually) enlarged system can cause interpretation and communication problems and needs special attention. The interpretation of the results can grow weaker and less transparent.

System expansion (including substitution) is applied, if it does not lead to misinterpretation or to an enlargement of the functional unit, because this would be in a conflict with the aim to provide single datasets with respective functional unit.

In GaBi database, work system expansion is frequently applied to energy by-products of combined or integrated production, where direct use in the same system is not feasible.

Allocation is the third method to deal with multi-functionality. Allocation has long been discussed and debated, despite the fact that often only one feasible or useful allocation rule is applicable and the relevance of different allocation keys is frequently of rather low relevance on the results.

Identification of the most appropriate allocation key is essential and often intuitive. The inputs and outputs of the system are partitioned between different products or functions in a way that reflects the underlying physical relationships between them, i.e., they should reflect the way in which the inputs and outputs are changed by quantitative changes in the products or functions delivered by the system. Wherever possible, physical relationships are utilised to reflect meaningful shares of the burden.

Whereas physical relationships alone cannot be established or used as the basis for allocation, the inputs are allocated between the products and functions in proportion to the economic value of the products.

Sensitivity analysis of possible choices is helpful to justify a decision. Allocation always works and the sum of the allocated emissions is 100% of the actual total amount of emissions. Allocation is applied in GaBi, where subdivision and system expansion (including substitution) fail on the practical level.

If there is a significant influence on the results due to an allocation, a sensitivity analysis can transparently show the effects and enable interpretations of the results. Different datasets for the same product with different allocation keys may be supplied to document relevant sensitivity and to be able to choose the right one in a given goal and scope.

Our experiences from research and industry projects have shown over time that allocation – using appropriate allocation keys – is a suitable tool for distributing environmental burdens to specific products. Scenario calculation and sensitivity analysis to quantify the influences of changing allocation keys are particularly effective.

4.5 Generic Modules as background building block

Some industrial processes or natural systems are highly complex (see Chapter 2.3). Their complexity is not only characterised by the amount of required materials and processes, but also by their non-linearity in relating to each other. Complex systems can be often found in electronic products (many materials, parts and process steps), agrarian systems (natural processes interfering with technical processes with unclear boundaries) and construction systems of complex use and secondary effects. If the required materials and processes are the same for several different systems, the model can be parameterised once and adapted for each purpose individually – as long as the complex relationship is the same and integrated in the model.

The generic module approach is applied to manage complex product models and provides the opportunity to produce transparent and summarised results within an acceptable timeframe. Generic modules comprise flexible models with parameter variations, including already-modelled materials and parts. These parameters allow the variation of system models based on technical dependencies (technically understandable and interpretable parameters). The parameter variation offers the possibility to adapt the models to specific product properties or modelling design scenarios without the need to create entirely new models.

Generic modules are used for single processes, system parts or the complete manufacturing of a product. Varying significant parameters allows each individual module of the product chain to be specified. By implementing the entire manufacturing process into a modelled Life Cycle, all effects to each life cycle phase can be recognised according to the different variations.

4.6 Special modelling features for specific areas

In the following paragraphs, specific modelling issues are addressed for key areas, which are applied in the GABI database [GABI]:

- Energy
- Road Transport
- Metals and steels

- Chemistry and Plastics
- Construction
- Renewables
- Electronics
- End-of-Life

4.6.1 Energy

Energy is a core issue because its supply and use influences the performance of most industrial products and services.

Energy supply systems differ significantly from region to region, due to individual power plant parks and individual energy carrier supply routes.

Due to its specific situation in different regions and the related complexity, the modelling of the energy supply takes place at different levels:

- Supply of different energy carriers (e.g., different energy resources)
- Creation of country-/ region-specific mixes for each single energy carrier (e.g., natural gas mix Germany, crude oil mix EU-27)
- Supply of final energy from conversion to liquid fuels such as gasoline and diesel fuel
- Supply of the final energy by conversion to electricity, thermal energy and steam

For detailed modelling the technical processes necessary for the supply of renewable and non-renewable sources of energy, as well as the analysis of the power plant technology/refinery used in each case for the production of electricity/fuel, are required.

Supply of Energy Carriers

The supply of an energy carrier includes exploration and installation of the production site, production and processing. Figure 4-2 shows the natural gas production in Germany as an example to clarify how the energy carrier supply is modelled. Among the considerations is the need for auxiliary materials for the drilling during exploration of the gas fields, the energy demand for exploitation of the energy carriers, as well as further consumption and losses, such as venting and flaring of gas during production.

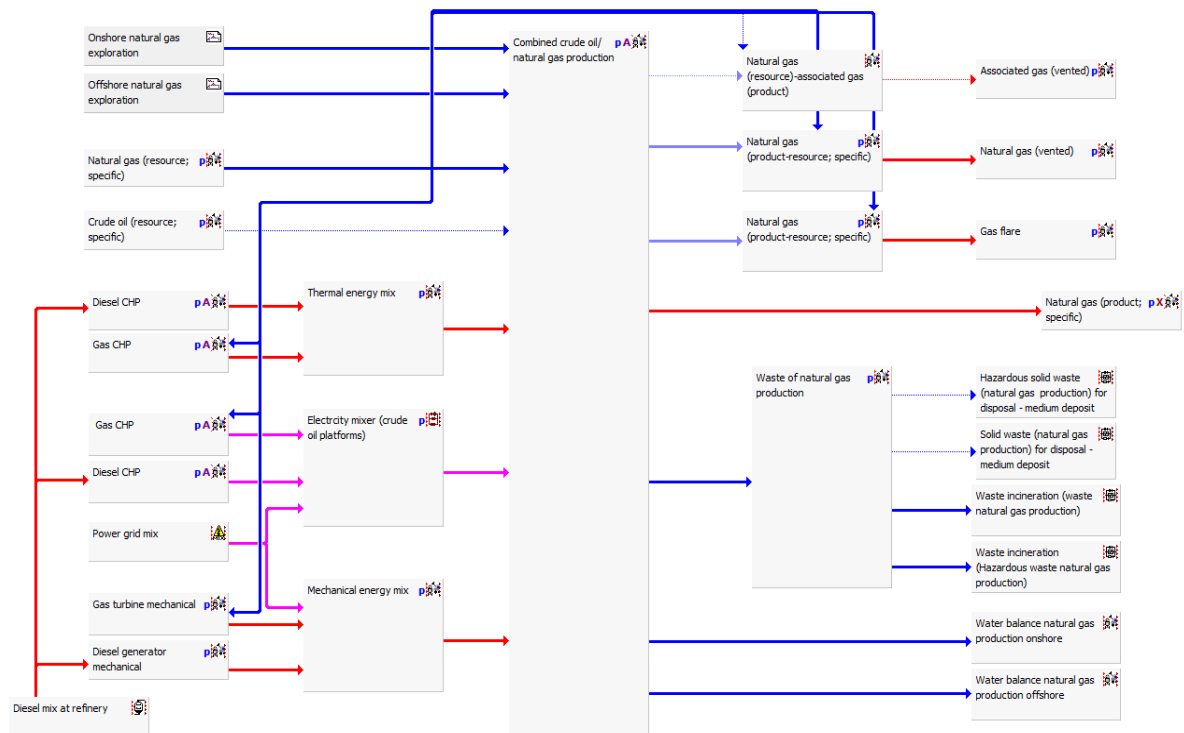

Figure 4-2: Conventional natural gas production in Germany

For the combined crude oil and natural gas production, allocation by energy content (based on net calorific value) is applied.

Associated gas and wastewater from crude oil production is allocated only to crude oil production. Vented gas and wastewater from natural gas production is only allocated to natural gas production.

Energy Carrier Mix

For the countries addressed in the GaBi Database, the energy carrier supply mixes (consumption mixes) have been analyzed and modelled. The consumption mixes of the main energy carriers, natural gas, crude oil and hard coal, have been analyzed and modelled in great detail to ensure the needed specification. The information about the different shares and sources are based on statistical information.



Figure 4-3: Natural gas supply for Germany

Production of electricity, thermal energy and steam

Through the utilisation of different energy carriers like gas, oil and coal in their respective power plants, electricity, thermal energy and steam is produced. The country-specific power plant technologies (efficiency of conversion, exhaust-gas treatment technologies and their efficiencies) are considered.

In addition, direct and combined heat and power generation are considered separately, depending upon the country-/region-specific situation.

Generic modelling of the power plants enables consideration of both fuel-dependent (e.g., CO₂) and technology-dependent (e.g., NO_x, polycyclic aromatics) emissions, including the effects of emission reduction measures (e.g., flue gas desulphurisation).

Mass and energy flows, including auxiliary materials (e.g., lime for desulphurisation), are considered during the energy conversion. The emissions of the power plant and the material and energetic losses (waste heat) are also taken into consideration. Figure 4-4 shows the modelling of the US, East power grid mix.

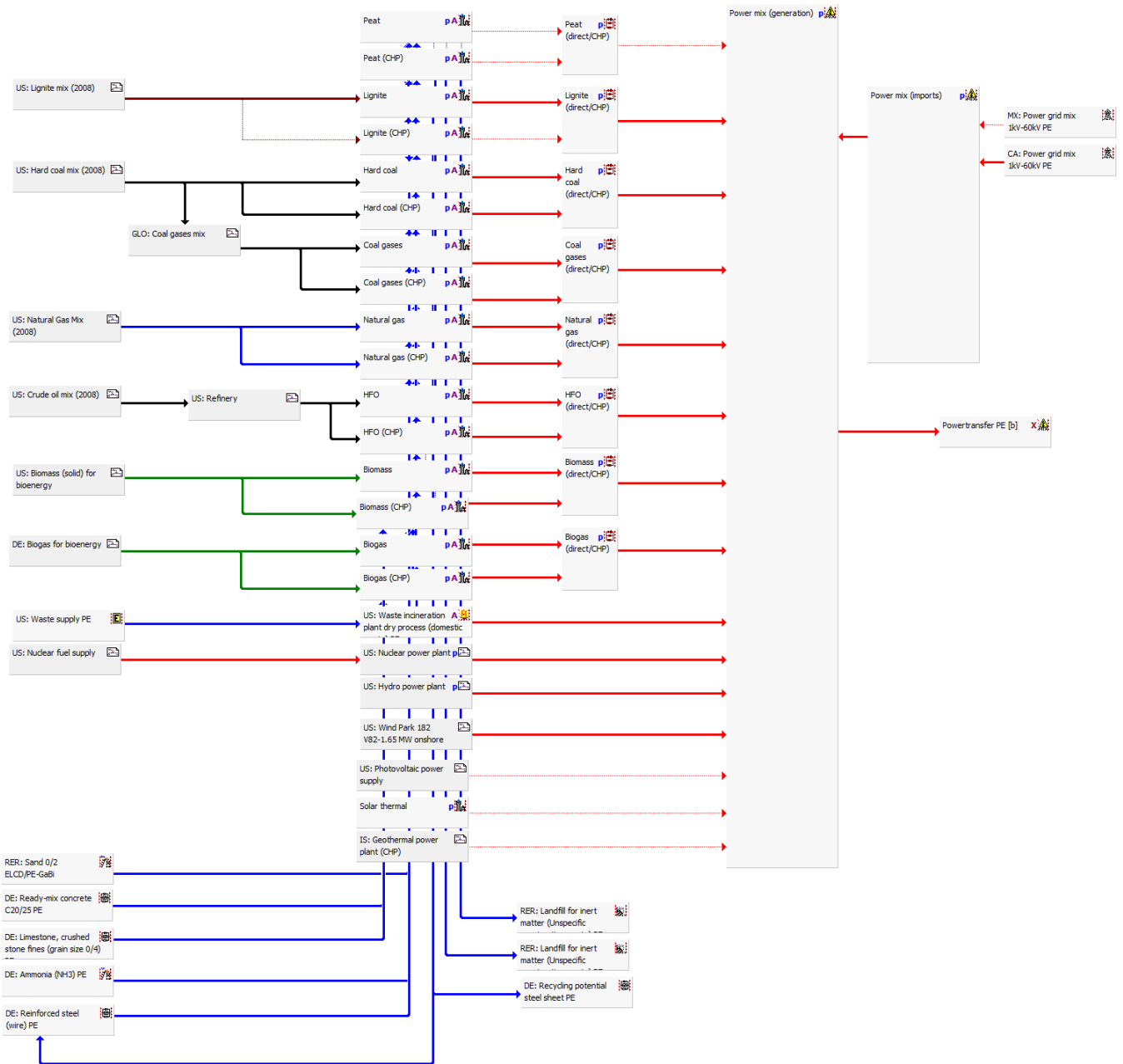

Figure 4-4:US, East electricity grid mix

The parameterised unit process models in the centre of the plan system are all comprehensive input-output relations based on several technology settings and calculation steps to represent the given regional technology. The following figure provides insight to the degree of engineering detail of the GaBi power plant models.

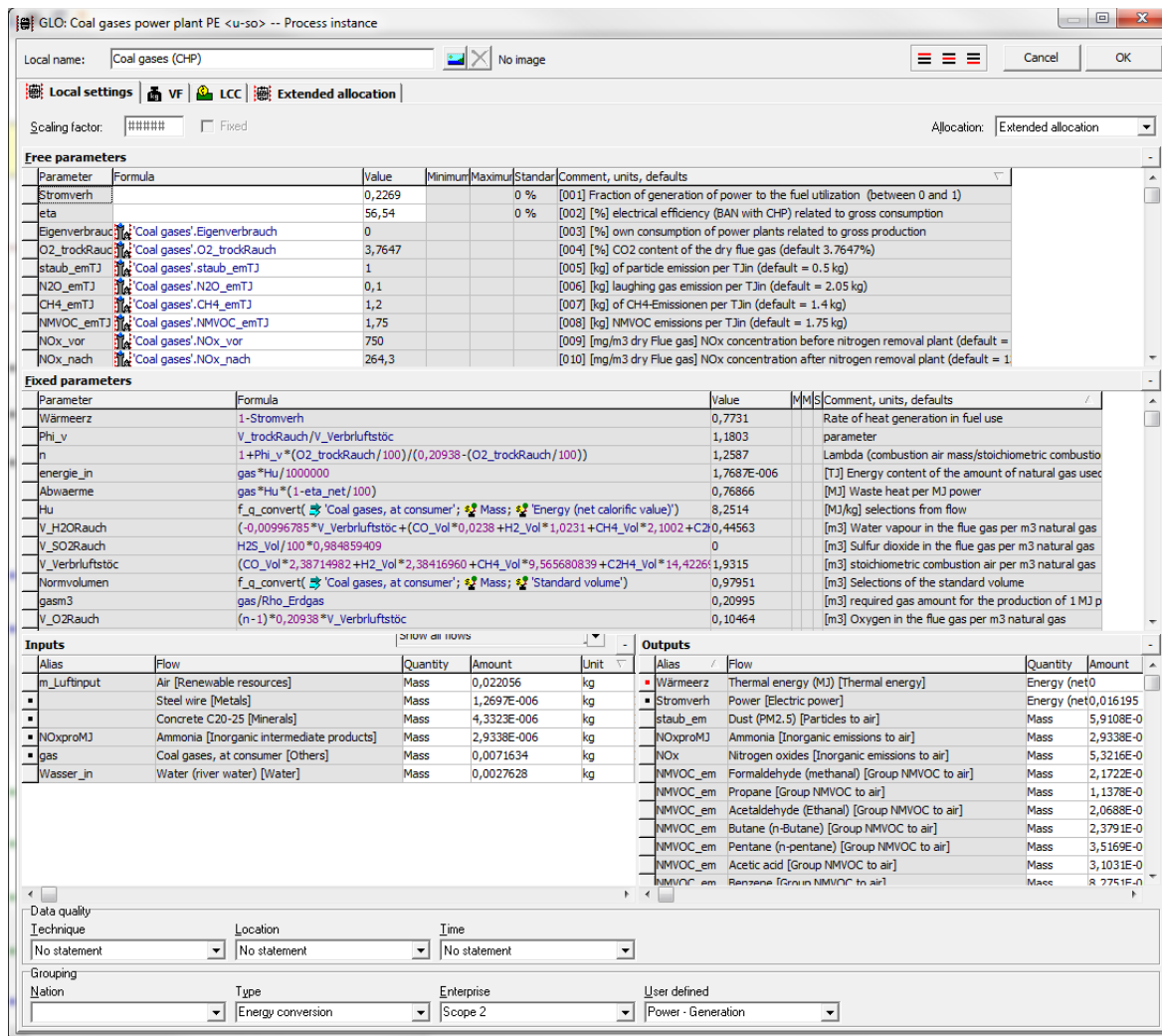

Figure 4-5:Parameterized US Coal gas CHP power plant

For the combined heat and power production, allocation by exergetic content is applied. For the electricity generation and by-products, e.g., gypsum, allocation by market value is applied due to no common physical properties. Within the refinery, allocation by net calorific value and mass is used. For the combined crude oil, natural gas and natural gas liquids, production allocation by net calorific value is applied.

Energy consumption by power plants themselves and transmission losses of the electricity from the power plants to the consumers are included in the analysis.

GHG emissions in hydropower plants and geothermal power plants

Non-combustion emissions released in hydropower plants and geothermal power plants are significant, however not always commonly addressed. In GaBi Databases these emissions are accounted for as it is important to gain adequate results, especially if renewable electricity generation is a significant part of a national grid mix and to be consistent regarding other options of electricity generation. From an LCA perspective there are relevant but still few sources concerning these emissions, which can be adequately used in LCI databases. The topic and

regionally different effects is also still debated in science. However, Sphera collects and validates information on this topic and frequently checks it against new and updated information in our yearly upgrade process.

In the case of **geothermal power plants**, CO₂, CH₄ and H₂S emissions as well as SF₆ emissions (in electrical equipment use) play a significant role. Validation backbone of the emissions data applied in Sphera's GaBi LCI models is the Report: "Emissions of greenhouse gases in Iceland from 1990 to 2010, National Inventory Report 2012". Facts and figures reported here are combined with the knowhow of our energy engineers into best available LCA data and frequently revisited and updated, if knowhow develops.

Concerning **hydro power plants**, CO₂ and CH₄ emissions as a result of degradation of biomass in the dammed water play a significant role. Depending on the climatic boundary conditions different effects arise. In climatic cold and moderate regions: Increasing CO₂ emissions from aerobic degradation of biomass in the first years of operation, then temporary decreasing within the first 10 years of operation. In climatic tropical regions: Increasing CH₄ emissions from anaerobic degradation of biomass in the first years then slower temporary decreasing, which can be longer than the first 10 years of operation. Vegetal boundary conditions (amount of inundated biomass) plays also a significant role. The used values of emissions are arithmetic mean values over 100 years of operation and are based on gross greenhouse gas emissions (problem of absorbed CO₂ from atmosphere), net emissions are estimated to be 30 – 50 % lower. Greenhouse gas emissions of run-of-river plants are minimal since the water is not stored for a long time. Validation backbone of the emissions data applied in Sphera's GaBi LCI models is the Report: "Addressing Biogenic Greenhouse Gas Emissions from Hydropower in LCA; Edgar G. Hertwich; Industrial Ecology Programme and Department of Energy and Process Engineering, Norwegian University of Science and Technology (NTNU)". Facts and figures reported here are combined with the knowhow of our energy engineers into best available LCA data and frequently revisited and updated, if knowhow develops.

The difference of thermal energy and process steam

The GaBi database offers country-specific datasets for thermal energy and process steam by energy carrier. For example, the datasets "US: Thermal energy from natural gas" and "US: Process steam from natural gas 90%" are available for natural gas. In the GaBi Databases, all process steam and thermal energy datasets refer to the same functional unit of 1 MJ of final energy delivered ("at heat plant").

The difference between the two types of datasets is related to the conversion efficiency of the energy carrier consumed to the final energy (steam, thermal energy) produced by the conversion process (heat plant).

While the LCI datasets for process steam are provided with several conversion efficiencies, i.e., 85%, 90% and 95%, the thermal energy datasets are calculated with an efficiency of 100% by

definition. The thermal energy datasets therefore represent emission equivalents of the energy carrier consumed in the conversion process.

For practical LCI modelling:

If the amount of fuel (energy carrier), which is converted to final energy, e.g., litres of heavy fuel oil or kilograms of coal consumed, is known, then use the thermal energy processes. In contrast, if the amount of final energy, e.g., MJ of process steam, is known, then use the process steam processes. The latter is also to be used if the process steam in MJ is further translated into kg of process steam.

In addition to calculating conversion efficiencies, both types of LCI datasets also consider the energy self-consumption by the heat plants. Due to this fact, the “overall process system efficiency” is in reality lower than the conversion efficiency (mentioned above). The conversion efficiencies of 100%, 95%, 90% and 85% should be documented accordingly as conversion efficiencies.

Summary of most important aspects applied in GaBi energy modelling

- Country-/region-specific resources extraction technology (primary, secondary, tertiary)
- Country-/region-specific power plant and conversion technology
- Country-/region-specific production and consumption mix of energy
- Country-/region-specific transport chains (pipeline, tanker, LNG tanker)
- Specific efficiencies and specific emission equivalents per fuel use
- Specific resource/fuel characterization per region
- Qualities and characteristics of fuel properties used in power plant models
- Parameterised models for emission calculations (specific standards adapted)
- Country-/region-specific refinery technology
- Unit process modelling based on engineering figures (no black box unit processes)
- Modular energy data provision (separate upstream data, fuel data, consumption mix data, fuel specific electricity generation data, country grid mix data)
- Deep regionalisation of energy data on all levels and layers of the life cycle model
- Adaptable electricity grid mix data

These main aspects ensure a reliable background database and enable the GaBi user to use the best practise energy data.

For more on energy modelling behind the GaBi datasets incl. details on refinery model, please see the respective documents on <http://www.gabi-software.com/index.php?id=8375>.

4.6.2 Transport

Transport is the link between process chain steps at different locations. Road, Rail, Air, Ship and Pipeline transports are the main modes of transport; however, the GaBi background model contains other modes of transport such as excavators, mining trucks and conveyors.

4.6.2.1 Road transport¹⁷

Transportation systems are found in the use phase, which contains the fuel demand and released emissions. The functional units are the following:

- transportation of 1 kg cargo over a distance of 100 km for truck processes
- 1 vehicle-kilometer for passenger car processes. In the case of a car, the manufacturing and end of life phases can be connected to the utilisation model.

Adaptable parameters in the datasets are: distance, utilisation ratio, share of road categories (urban/rural/motorway), required sulphur content and share of biogenic CO₂ in fuel and total payload (total payload only applies to trucks).

Because transportation processes are very specific for each situation, these processes are delivered as parameterised processes for individual adaptation.

Calculation of emissions

The basis for the emission calculation for both trucks and passenger cars is emission factors from literature [HBEFA 2010].

With the assumption that the utilisation ratio behaves linearly (see [BORKEN ET AL. 1999]), the Emissions Factors (EF) [g/km] for 1 kg of cargo can be calculated with the following equation:

$$Emission = \frac{EF_{empty} + (EF_{loaded} - EF_{empty}) \cdot utilisation}{payload \cdot 1000 \cdot utilisation} \quad \left[\frac{g}{km \cdot kg} \right]$$

EF _{empty}	Emission factor for empty run [g/km]
EF _{loaded}	Emission factor for loaded run [g/km]
utilisation	Utilisation ratio referred to mass [-]
payload	Maximum payload capacity [t]

The payload and utilisation ratios are variable parameters, which can be set individually by the dataset user.

The total emissions for each pollutant refer to 1 kg cargo (truck) and 1 km (passenger car) and the transportation distance is calculated based on the driving share (urban: share_ur / rural: share_ru / motorway: share_mw), the specific emissions (urEm, ruEm, mwEm) in [g/(km*kg)] and the distance [km].

¹⁷ For further in-depths information on duty vehicles and passenger vehicles. Please check out the respective documents found at <http://www.gabi-software.com/index.php?id=8375>

Equation for trucks:

$$Total-Emission_x = ((share_mw \cdot mw_{Em}) + (share_ru \cdot ru_{Em}) + (share_ur \cdot ur_{Em})) \cdot distance$$

x	Index for a specific pollutant [-]
share_mw	Driving share on motorway [%]
mw _{Em}	Motorway specific emissions [g/(km*kg)]
share_ru	Driving share on interurban road [%]
ru _{Em}	Interurban specific emissions [g/(km*kg)]
share_ur	Driving share on urban road [%]
ur _{Em}	Urban road specific emissions [g/(km*kg)]
distance	Driven distance [km]

Equation for passenger cars:

$$Total-Emission_x = ((share_mw \cdot mw_{Em}) + (share_ru \cdot ru_{Em}) + (share_ur \cdot ur_{Em}))$$

x	Index for a specific pollutant [-]
share_mw	Driving share on motorway [%]
mw _{Em}	Motorway specific emissions [g/(km*kg)]
share_ru	Driving share on interurban road [%]
ru _{Em}	Interurban specific emissions [g/(km*kg)]
share_ur	Driving share on urban road [%]
ur _{Em}	Urban road specific emissions [g/(km*kg)]

For CO₂ emissions, the calculations are based on the emission factors according to the previous equations, where a constant relation of 3.175 kg CO₂/kg fuel for fuel consumption is assumed. A medium density of 0.832 kg/l (diesel), results in 2.642 kg CO₂/l diesel, and a medium density of 0.742 kg/l (gasoline), results in 2.356 kg CO₂/l gasoline. Due to biogenic shares in today's fuel, the possibility is given to select the share of biogenic CO₂ emissions of the total CO₂ emissions.

For sulphur dioxide, a complete stoichiometric conversion of the sulphur contained in the fuel and of oxygen into SO₂ is assumed. The sulphur content in the fuel is a variable parameter, which can be set individually by the user.

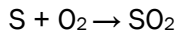

$$EF_{SO_2} = \frac{x_{ppm_S}}{1\,000\,000} \frac{kg_S}{kg_{fuel}} \cdot \frac{64g_{SO_2}}{32g_S} \cdot fuel_consumption \frac{kg_{Diesel}}{kg_{Cargo}} \left[\frac{kg_{SO_2}}{kg_{Cargo}} \right]$$

EF_{SO₂}Emission factor for SO₂

x_{ppm_S}Mass share in fuel

The emission factor for laughing gas (nitrous oxide, N₂O) is assumed to be constant for each emission class and each category of driving road. The emission factor for ammonia (NH₃) is set as constant throughout all categories.

The following systems and emissions are excluded:

- Vehicle production (for passenger car integration is possible due to existing valuable flow)
- Vehicle disposal (for passenger car integration is possible due to existing valuable flow)
- Infrastructure (road)
- Noise
- Diurnal losses and fuelling losses
- Evaporation losses due to Hot-Soak-Emission
- Oil consumption
- Cold-Start Emissions
- Emissions from air conditioner (relevance < 1% see [SCHWARZ ET AL. 1999])
- Tire and brake abrasion

Representativeness

Concerning representativeness, the emission classes from “Pre-Euro” to “Euro 6” are covered. The technologies are representative throughout Europe and can be adapted for worldwide locations with a few restrictions. There is a need to identify the corresponding emission classes.

The referring locations are Germany, Austria and Switzerland. Due to the similarity of the vehicle structure and the same emissions limit values, the models are representative for the entire EU. With a few restrictions, the model can be assigned to other countries worldwide. Attention should be paid to the fact that the imprecision increases with the increase of the deviation of the vehicle structure as the basis. The road categories and the utilisation behaviour also affect imprecision. An adaptation can be carried out by setting the driving share (mw/ru/ur), as well as the utilisation ratio and sulphur content in the fuel, for individual conditions.

The reference year of the dataset is 2017, that data is representative for the period until 2020.

Modification of the age structure of vehicles for each emission class leads to changes of the emission profile. The validity of the dataset is given until 2020. Prognoses in [HBEFA 2010] based on comprehensive time series report that there is no change of emission profiles within a certain size class, emissions class or road category. Only the different composition of the total vehicle fleet results in changes over time.

Negative photochemical oxidation figures due to NO_x/NO/NO₂ figures

The photochemical oxidation, very often defined as summer smog, is the result of very complex still partly unknown reactions that take place between nitrogen oxides (NO_x) and volatile organic compounds (VOC) exposed to UV radiation. The Photochemical Ozone Creation Potential, POCP, of some VOC's is related to a reference substance, in this case, the olefin ethylene (H₂C=CH₂) that relates the impact of the substances to the impact of the reference C₂H₄.

VOCs have different reactivity's with oxidants (Ozone, HO, NO₂, NO,...) in the atmosphere and therefore they have different (positive and negative) effects on the Ozone formation in the troposphere, which are still under scientific research.

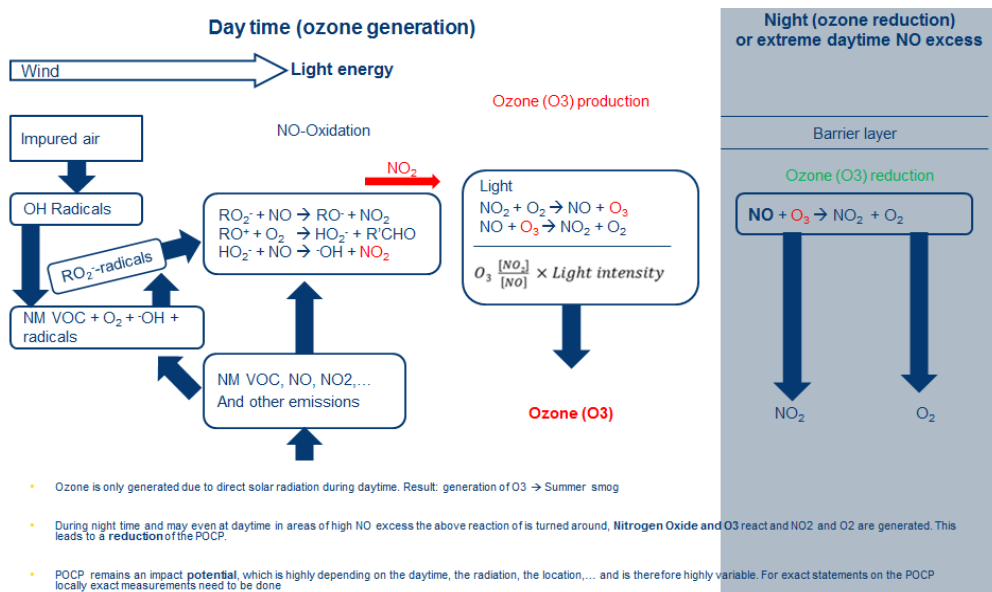

Figure 4-6: Principle known functions of tropospheric ozone creation and reduction

Source : <http://www.umwelt.nrw.de/umwelt/luftqualitaet/ozon/bodennah.php>

The emission spectrum of the truck transports within Sphera databases are taken from the „Handbook emission factors for road transport (HBEFA)”. It can be found under: <https://www.hbefa.net/e/index.html>

In the course of the last upgrades of GaBi Databases, NO_x emissions have been separated in the NO₂ and NO emissions as requested by users, handbooks and LCIA models to model more specifically.

Due to the split of NO_x a potential negative value for the POCP may occur, according to the certain impact models chosen. Remind that during night NO and O₃ react to NO₂ and O₂ and a reduction of the POCP is taking place. NO is characterized in certain POCP methods in CML 2001 since several years with a factor of -2,34. An overview of all weighting factors can be found under: <https://www.universiteitleiden.nl/en/research/research-output/science/cml-ia-characterisation-factors> .

In earlier studies NO_x (as sum of NO + NO₂ measured as and in NO₂ eq.) was modelled in off gases (impact factor NO₂ > 0). Today, NO_x is requested to be split in NO + NO₂ (possible for LCI). However, the exact NO_x chemistry is still hardly to define. LCIA gives factors for NO < 0 and NO₂ > 0 or only NO or NO₂ or NO_x. In many off gases technically NO > NO₂ so resulting net negative impact may occur.

If this effect and the LCI emission as such is in core of your study or dominating the results it is recommended to do sensitivity analysis by taking NO_x/NO and NO₂ factors and quantify the impact variation (ISO practice).

4.6.2.2 Air Transport

The functional unit of air transportation processes is the transportation of 1 kg cargo over a distance of 2500 km. Adaptable variable parameters in the parameterised datasets (with default setting) are: distance (2500 km), utilisation ratio (66%), sulphur content of fuel (400 ppm) and share of biogenic CO₂ (0%). Three payload capacity categories (22 t / 65 t / 113 t) are addressed based on technical parameters and properties of A320 / A330 / B747 aircraft.

Inputs: Kerosene and cargo.

Outputs: Cargo and combustion emissions (carbon dioxide, carbon monoxide, methane, nitrogen oxides, NMVOC, sulphur dioxide, dust)

Not included in the datasets are plane production, end-of-life treatment of the plane and the fuel supply chain (emissions of exploration, refinery and transportation).

The fuel supply dataset (kerosene) must be linked with the dataset.

The foundation of the data is specifications for A320 / A330 / B747 aircraft, as well as the Third Edition of the Atmospheric Emission Inventory Guidebook [EMEP/CORINAIR 2002].

4.6.2.3 Rail Transport

Rail transport processes cover transportation of bulk commodities or packaged goods via light, average and extra-large diesel and/or electric cargo train. The functional unit is the transportation of 1 kg cargo over a distance of 100 km. Variable parameters (with default setting) are: distance (100 km), utilisation (40 %) and for diesel trains the sulphur content of fuel (10 ppm), share of biogenic CO₂ (5 %) and the emission standard of the locomotive (UIC II).

The following attribution of emission standard to specific regions can be done:

- 1 = UIC I: Developing countries, international standard for old locomotives manufactured before 2002
- 2 = UIC II: Europe and Global default, international standard for locomotives manufactured 2003-2008
- 3 = Stage IIIb: Europe, for locomotives manufactured after 2012
- 4 = Tier 2: North America, for locomotives manufactured 2005 - 2011
- 5 = Tier 4: North America, for locomotives manufactured after 2015
- 6 = DB: Germany, for mix of locomotives running in 2016

Inputs: Diesel/electricity and cargo

Outputs: Cargo and for the diesel train also combustion emissions

Train production, end-of-life treatment of the train and upstream processes for fuel/electricity production are not included in the dataset.

The fuel/electricity supply dataset must be linked with the dataset.

The datasets are mainly based on literature data. [ECOTRANSIT2010], [IFEU 2010]

4.6.2.4 Ship Transport

Ship transport processes cover transportation of various goods via several inland, coastal and ocean-going vessels. The functional unit is the transportation of 1 kg of cargo over a distance of 100 km. Variable parameters (with the default setting) are: distance start to destination of transported cargo (100 km), capacity utilisation (65% for inland vessels and 48% - 70 % for ocean-going vessels), sulphur content of fuel (50 ppm for inland vessels up to 2.7% for ocean-going vessels), share of biogenic CO₂ (5% for inland vessels and 0% for ocean-going vessels) and deadweight tonnage for ocean-going vessels (8000 tons for Ro-ro ships up to 160,000 DWT for oil tankers).

Inputs: Fuel and cargo

Outputs: Cargo and combustion emissions (carbon dioxide, carbon monoxide, methane, nitrogen oxides, nitrous oxide, NMVOC, particulate matter PM 2.5, sulphur dioxide)

Vessel production, end-of-life treatment of the vessel and the fuel supply chain (emissions of exploration, refinery and transportation) are not included in the dataset.

The datasets are mainly based on literature data from the International Maritime Organization [IMO 20], technical information [VBD 2003], emission data from the European Energy Agency [EMEP/CORINAIR 2006] and the Intergovernmental Panel on Climate Change [IPCC 2006].

4.6.2.5 Transport of fluids in pipelines

The LCI dataset should be used for LCI/LCA studies where fluids must be transported via pipeline over a longer distance. The dataset allows individual settings of the variable parameters. The following parameters are variable (default settings): utilisation ratio (28%) and distance (100 km). Default values of the variable parameters must be checked and adjusted for individual use. The dataset does not include the energy supply route. Therefore, the energy supply dataset (electricity) must be linked with this dataset.

The pipeline transport processes can be used to model transportation of fluids in continuous working pipelines. Some representative diameters (0.4 to 1 m) and gradients of pipelines are analyzed, because many variations are possible. The specific energy consumptions as a function of the utilisation ratio are determined from four basis formulas. The different energy consumption of different diameters over the utilisation ratio can therefore be calculated. The average utilisation ratio is approximately 28%. Two ranges of diameters and two different gradients are shown. Additionally, an average pipeline was calculated. The transported kilometers and the mass of the cargo are known, so the energy consumption in MJ of electricity can be calculated. The distance and the mass of the transported cargo must be entered by the user. Different pipelines can be chosen (varying the gradient and diameter). The energy consumption is calculated per ton cargo.

Inputs: Cargo and electric power

Outputs: Cargo

Not included in the datasets are pipeline production, end-of-life treatment of the pipeline and the electricity supply chain.

The main source of data is the energy consumption study for transportation systems of the RWTH Aachen [RWTH 1990].

4.6.2.6 Other Transport

Other transport consists of excavators for construction works and mining activities, as well as mining trucks. The functional unit is the handling of 1 t of excavated material. Vehicle performance, load factor, fuel consumption, emission factors, sulphur content of fuel and other technical boundary conditions can be individually adapted via variable parameters. The predefined parameter settings represent an average performance of the vehicle.

Inputs: Diesel and excavated material

Outputs: Excavated material and combustion emissions due to engine operation, including regulated emissions (NO_x, CO, Hydrocarbons and Particles), fuel-dependent emissions (CO₂, SO₂, benzene, toluene and xylene) and others such as CH₄ and N₂O

Not included in the datasets are vehicle production, end-of-life treatment of the vehicle and the fuel supply chain.

The datasets are mainly based on vehicle-specific technical data, as well as averaged literature data for emission profiles from the European Energy Agency [EMEP/CORINAIR 2006B].

4.6.3 Mining, metals and metallurgy

Primary metals are sourced from metal ores containing several different metal components. The production of a certain metal is therefore typically accompanied by the production of metallic and non-metallic co-products, e.g., nickel production with cobalt, other platinum group metals and sulphuric acid.

To calculate the Life Cycle Inventory of a single metal, the multifunctionality between product and co-products must be addressed. Allocation is often the only suitable way to deal with these highly complex co-production issues in a way that the technical circumstances are properly reflected. The choice of an appropriate allocation key is important because the metals and other valuable substances contained in ores are very different concerning their physical properties and value.

For metals with different economic values (e.g., copper production with gold as a co-product), the market price of the metals is a suitable allocation factor. In order to maintain consistency in environmental impacts as market values vary, average market prices over several years (e.g., 10-year market averages) are used. In order to avoid influences from inflation, it is recommended to calculate the prices over the 10 years in relation to one specific year. This can be done using price deflators. Usually the market price for concentrate or metal ore cannot be easily determined and in this case, the market price is “derived” based on the metal content.

For other non-metallic co-products, such as the co-products sulphur, benzene, tar of coke for integrated steelwork creation, other allocation factors are applied, such as the net calorific value.

The metal datasets represent cradle-to-gate datasets of the actual technology mix, e.g., a region-specific mix of pyro-metallurgical and hydrometallurgical processes for the production of non-ferrous metals, covering all relevant technical process steps along the value chain, including mining, beneficiation (ore processing including jaw crushing, milling, Dense Media Separation, Heavy Media Separation (HMS)), smelting (e.g., rotary kiln, flash furnace, blast furnace, TSL furnace, electric arc furnace), magnetic separation or leaching and refining (chemical or electro).

The LCI modelling of the process steps mining and beneficiation considers the composition of the mined ore bodies and the related metal-, process- and site-specific recovery rate, e.g., mill recovery rates within copper production could be Cu (90%), Mo (75%), Ag (70%) and Au (70%).

Under the assumption that tailing dams include a lining system where water is captured and put back in settling dams or water treatment facilities for reuse, the tailing dam emissions are considered as water losses through evaporation of the tailing dam.

Metal Recycling

Considering and evaluating the potential and benefit of metal recycling in LCA depends on the specific characteristic of the data system (e.g., field of application, question to be answered, goal & scope). The following principles are to be taken into account in setting up the life cycle system as the basis for a suitable and representative database for metals:

- 1) **Market situation:** According to the specific market situation, the metal production of the system under study can be characterised as primary metal production, secondary metal production or the market mix from possible primary and secondary production routes.
- 2) **Upstream burden and downstream credit:** For metals recovery, the end of life consideration covering the recycling of metal (downstream credit) turns into an upstream consideration (upstream burden) from the viewpoint of the product system consuming the recovery metal. Chapter 4.3.4.2 Allocation procedure in ISO 14044 [ISO 14044: 2006] requires that allocation procedures must be uniformly applied to similar inputs and outputs of the product system under study, i.e., the use of recovered metal within a product system (=input) is to be treated equally from a methodological point of view to metal recovery from a product system (=output). Often this requirement is met by considering only the net amount of recovered metal to credit for metal recovery. The net amount of recovered metal is specified by the difference in the amount of metal recovery at the end of life of a product, as well as the use of recovered metal for production of the product system considered. This procedure is justified as only the metal loss over the complete product life cycle that is to be taken into account. Nevertheless, in doing so, the differences between the single life cycle phases (production, use and end of life) will be obliterated.
- 3) **100% primary / 100% secondary production routes:** It should be noted for Life Cycle Inventory modelling that in actual metal production a 100% primary or a 100% secondary route is not always given.
- 4) **Definition of key parameters:** A mutual understanding of the definitions and terms, e.g., Recycling rate in LCA = “Ratio of amount of material recycled compared to material introduced in the system initially” is highly important.

- 5) **End of Life scenario/situation “versus” End of Life methodology/approach:** It is necessary to distinguish between the End of Life scenario describing the recycling situation at products' End of Life, e.g., recycling into the same product system, no change in inherent material properties, and the (modelling) approaches/methodologies applied to consider and describe the resulting effects within LCA.

In LCA practice, various methodological approaches to consider the recycling of products at their End of Life phase within LCA are applied. Aspects to be considered in selecting the appropriate End of Life approach are: ISO-conformity, mass and energy balance, reflection of optimization and reality, data availability, transparency, easy communication and understanding, field of application and fairness (to any material or product application).

A harmonised and consistent description and discussion of these approaches can be found in PFLIEGER AND ILG 2007.¹⁸

4.6.4 Chemistry and plastics

Chemical and plastic products are key players toward environmental performance for two reasons: Chemical and plastic production uses substantial amounts of energy and resources but the resulting products help to save substantial amounts of energy or reduce environmental burden in suitable applications. Chemical and plastic products therefore provide an important foundation for many other industrial fields and products. In electronics, automotive and construction chemicals and plastics are used in various systems as input materials. It is therefore important to achieve a level of high engineering quality in the modelling of the processes in these fields.

Primary data collection and/or industrial feedback or validation of the information used, are the best choice. With specific engineering knowledge, data for chemical plants and operations can be developed with secondary information, thus making industry/expert feedback and validation even more important.

Data development of chemical processes follows a defined route in GaBi database work.

- 1) Information about current technologies is collected
- 2) Checking relevance for the given geographical representation
- 3) Defining the name of the reaction route(s). There is often more than one, even with the same reactants.

¹⁸ http://www.netzwerk-lebenszyklusdaten.de/cms/webdav/site/lca/groups/allPersonsActive/public/Projektberichte/NetLZD-Metalle_S01_v02_2007.pdf

- 4) Defining related stoichiometric equations
- 5) Defining suitable yields
- 6) Drawing a process flow sheet
- 7) Setting up the unit process network and the system

A validation or benchmark of the secondary data with existing data is done.

Modelling

For each material, several different processing technologies are often available. For example, for the production of polypropylene, “polymerisation in fluidised bed reactor” and “vertical stirred reactor” is both technologies that are applied. For each relevant technology, an individual process model is created.

Chemical and plastics production sites are often highly integrated. Modelling a single substance product chain is possible by isolating integrated production lines. The following figure gives a simplified overview for important organic networks.

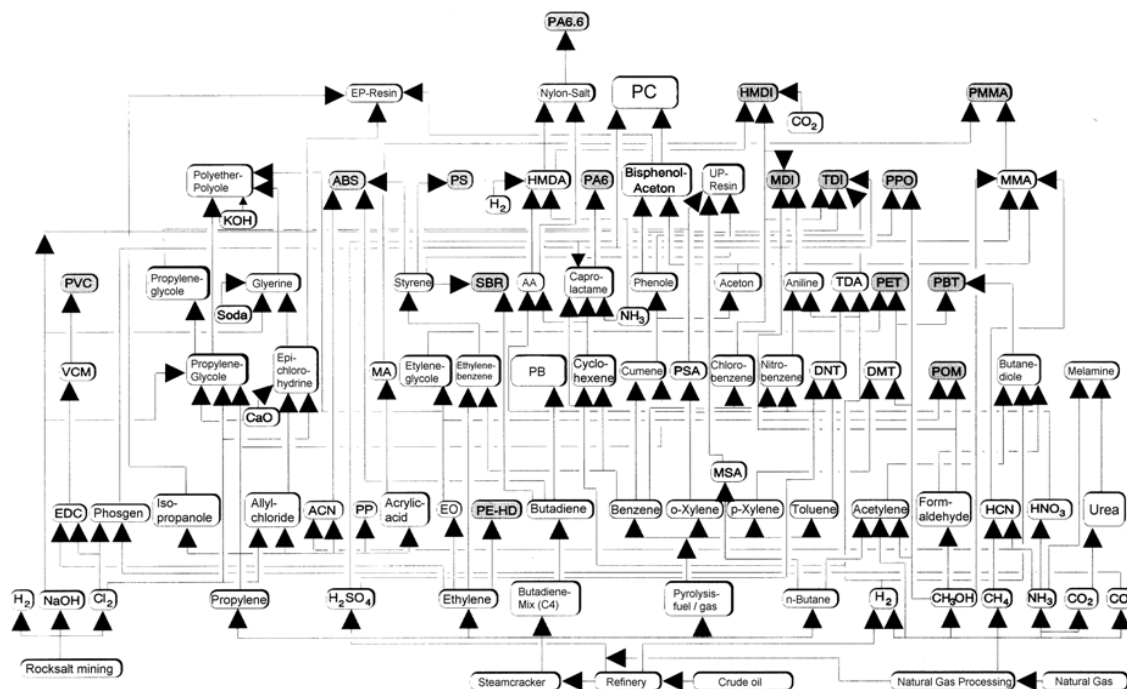

Figure 4-7: Excerpt of the organic network¹⁹ considered in GaBi

19 Acknowledgements to Dr. Manfred Schuckert for introducing the organic network thinking in the early 90s into GaBi.

To avoid inappropriate isolation measures it is essential to have engineering and technical information to accurately model those systems.

A well-arranged online overview of important parts of the chemical network is given on the Plastics Europe Homepage²⁰.

In case of chemical and plastics, it is not meaningful to apply generic modules because the technology specifications differ significantly. Country-specific consumption mixes are useful, because chemical and plastic products are traded worldwide, meaning that a chemical or plastic material, which is provided in a certain country, can be imported from other countries. For the creation of country-specific models, see Chapter 4.2.

Chemical processes often have a co-product system. Unit process isolation (subdivision) is preferable in this case. If it is not possible, energy products (e.g., fuel gases or steam) are substituted. For remaining by-products, allocation is applied. If all products and by-products have a calorific value, the allocation key energy is often used, because it is a good representation of value and upstream demand.

Waste and/or wastewater are always treated (landfill, incineration and/or wastewater treatment) if treatment pathways are obvious. The treatment technology (landfill or incineration or wastewater treatment) is selected according to the country-specific situation or individual information.

Production and consumption mix

As the users of the dataset are not always able or willing to determine the exact technology for the production of their upstream materials, a representative production mix or consumption mix is also provided. The share of production or consumption was determined, separately from the dataset for each relevant technology. For chemicals with different possible production routes, the technology mix represents the distribution of the production mix of each technology inside the reference area.

For example, the production of standard polypropylene in the different regions is based on different polymerisation technologies, including the fluidised bed reactor and the vertical stirred reactor. For standard polypropylene the main process models are mixed according to their share in industrial applications with an average polypropylene dataset.

The consumption mix considers the material trade. Figure 10 shows an example of a mix for the consumption of epoxy resin in Germany for the reference year 2011. The epoxy resin, which is

²⁰ <http://www.plasticseurope.org/plastics-sustainability/eco-profiles/browse-by-flowchart.aspx> (checked 03.11.2011)

consumed in Germany, is produced in Germany (53.4%), Switzerland (20.3%), the Netherlands (9.1%), Italy (8.5%), Spain (4.5%) and Belgium (4.2%), as seen in the following example.

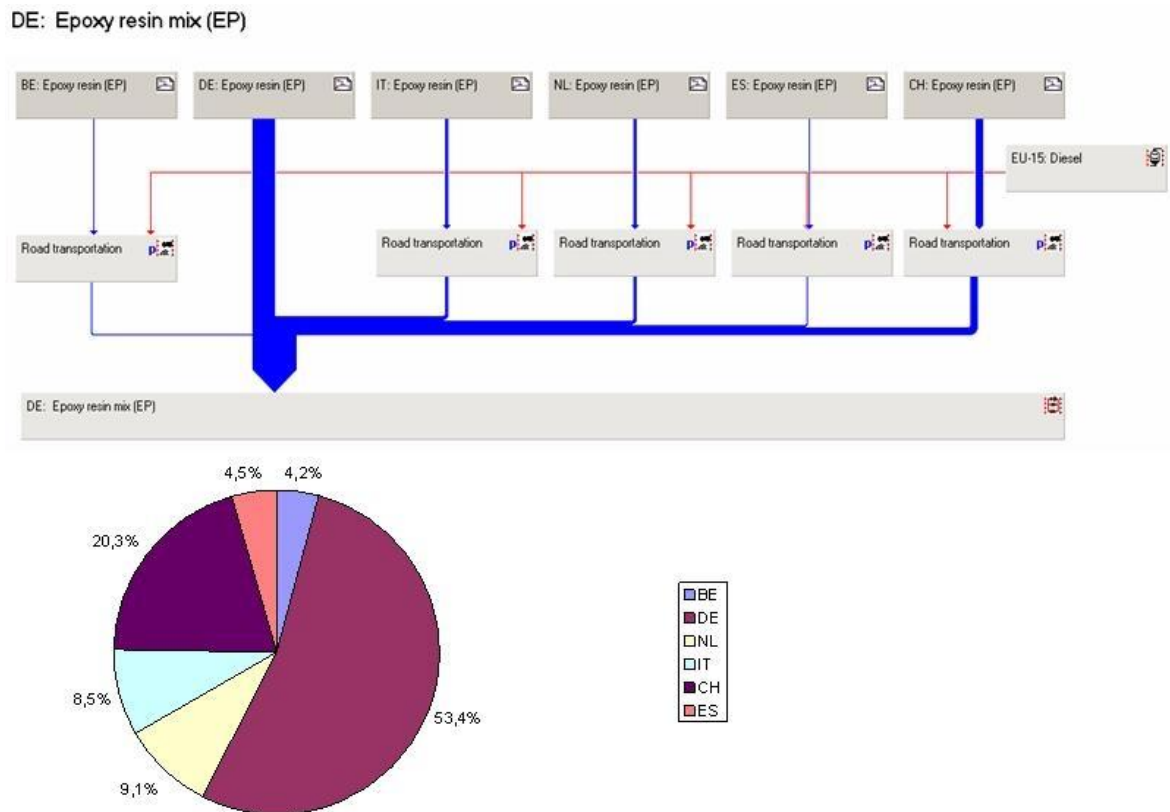

Figure 4-8: Consumption mix of Epoxy resin in Germany

Technology aspects

A suitable technology route is important for the proper modelling of chemical data. Technological differentiations in GaBi chemical process modelling are considered for different technology routes such as:

- Chlorine and NaOH (amalgam, diaphragm, membrane technology)
- Methanol (combined reforming stand alone and integrated)
- Steam Cracking (gas to naphtha input shares and related product spectrum)
- Hydrogen peroxide (SMA and Andrussov process)
- Hydrogen (steam reforming natural gas/fuel oil via synthesis gas, cracking/refinery by-product)
- Oxygen/nitrogen/argon (liquid or gaseous)
- Sulphuric acid (refining desulphurisation, fertiliser production, secondary metallurgy)
- Hydrochloric acid (primary, from epichlorohydrin synthesis, from allyl chloride synthesis, from methylene diisocyanate synthesis, from chlorobenzene synthesis)
- Benzene, toluene and xylene (from reformat or pyrolysis gas or dealkylation or by-product styrene)

- Acetone (via cumene or isopropanol)
- Hexamethylenediamine (via adipic acid or acrylonitrile)
- Titan dioxide (sulphate and chloride process)
- Caprolactam (via phenol or cyclohexane)
- Ethylene oxide (via O₂ or air)

The correct technology route for the right process chain can be decisive. Sphera's knowledge is constantly updated according to the latest developments in the chemical industry, including from being open to feedback and constructive comments while keeping the chemical networks up-to-date.

By-product handling

Methodological tools such as allocation or substitution open up ways to cope with any by-products. Technical reality guides GaBi modelling, first and foremost, before methodological choices are made. Prominent by-products are:

- steam (often not at a level of pressure that is directly compatible to the necessary input level)
- fuel gases
- various inorganic or organic acids
- purge or impure side streams
- unreacted monomers
- various salts

In GaBi chemical modelling the use or fate of by-products is investigated. Often chemical sites have a steam system with various feeds and withdrawing points with different temperature and pressure levels, which makes substitution of proper temperature and pressure level a suitable approach to handle the overall benefit of the by-product steam for the entire plant.

Fuel gases can often be used in firing or pre-heating the reaction within the plant, to reduce the use of primary sources. Related emissions are taken into account.

Acids are often sold. Allocation takes into account that those extracted acids must be cleaned, purified, diluted or concentrated.

Purge and impure side streams or unreacted monomers are often cycled back into the process after cleaning, distillation or purification.

Proper methodological handling and technical modelling based in fact are important.

Polymer modelling

Aside from the aforementioned topics of consistent mass and energy balances and the correct technology route, another aspect of polymer modelling should be mentioned: There is a difference between polymer granulate/resin, polymer compound and polymer part.

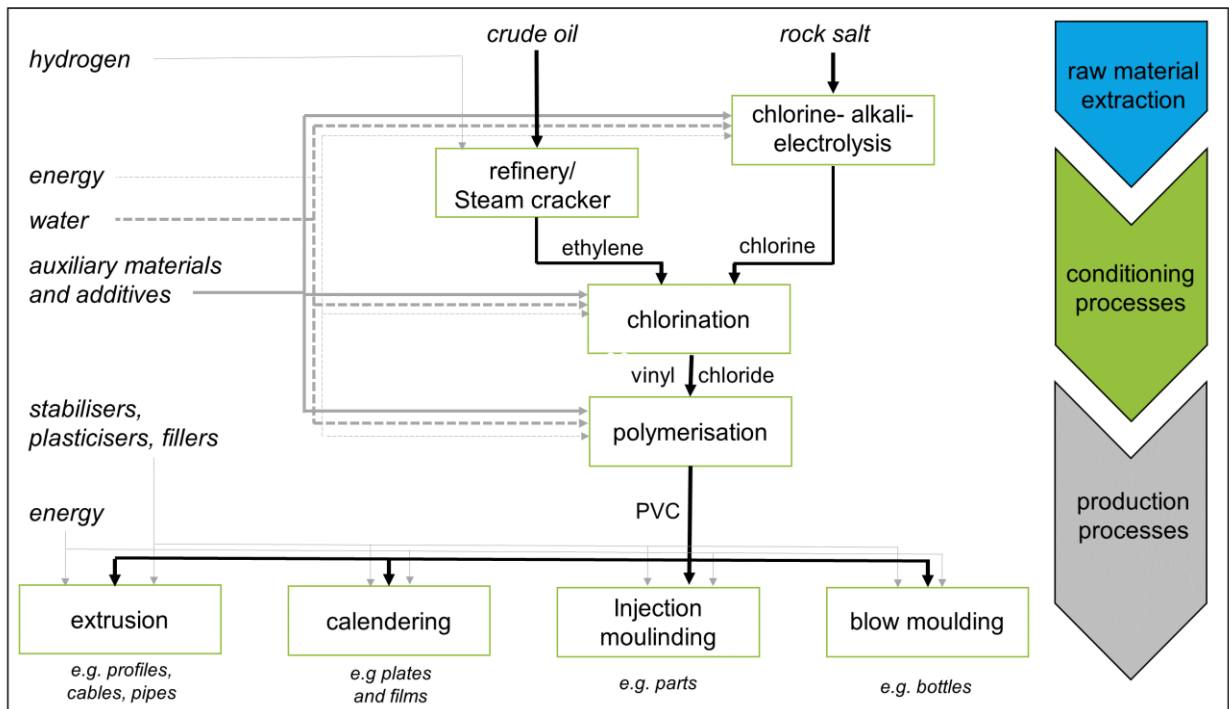

Figure 4-9: Example of PVC resin – compound- part

As compounds can be produced and used in thousands of specific recipes, GaBi primarily provides granulate data, which can be used individually to add additives to produce individual compounds and to set up individual polymer part data.

4.6.5 Construction

The construction sector uses extensive quantities of natural resources, raw materials and energy. Within the European Union, the construction sector is responsible for a share of 10% of the gross domestic product (GDP) and creates about 7% of the total employment. Considering their entire life cycle, buildings and construction products are responsible for the consumption of approximately 40% of the total European energy consumption, as well as for the consumption of approximately 40-50% of natural resources.

The anthropogenic material flows caused by the life cycle of buildings contribute through many environmental categories to the impact potentials. In order to describe a building during the entire life-cycle, various information concerning the depletion of mineral resources (mining and production of building materials), depletion of energetic resources and release of pollutants (construction material production and transport, energy supply of production and during utilisation of the building), land use (a quarry and surface sealing by the building) and waste treatment (construction, use, renovation, demolition) is required.

To structure these datasets, the life cycle is systematically divided into several unit-processes, respectively forming a chain, becoming a network that represents the mass and energy flows caused by a building from cradle to grave (see Figure 4-10).

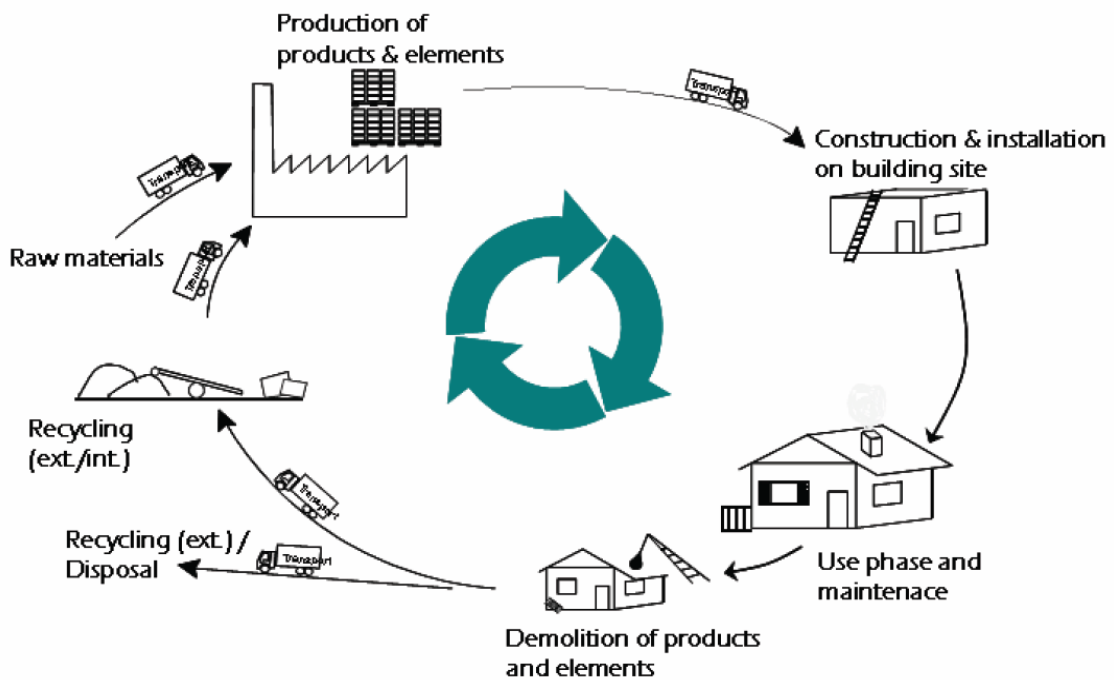

Figure 4-10: Schematic life cycle of a building

Every construction building product is produced in order to fulfil a function within building or construction. Accordingly, analyzing individual construction materials should not be done without employing a functional unit that considers the construction material's purpose or without considering where it is intended to be used. The functional unit should always include the performance of a material within a building structure. Simple comparisons on the basis of mass are misleading.

The background data (e.g., transport, energy supply) used to model the production of construction materials must be comparable. It will be true for system boundaries and methodological key points (such as cut-off-criteria and allocation rules), and may influence the result considerably. For construction materials, the consistent GaBi background system is used.

The GABI database [GABI] for construction materials covers the most relevant construction materials, as well as more specialised materials used in the construction of buildings, roads or subsurface constructions. It is divided into mineral products (including concrete and concrete products, bricks, sand lime, natural stones, as well as mineral insulation materials such as rock wool and glass wool), metals (construction), polymers (for construction, including insulation materials such as PUR, EPS or XPS), wood for construction, cement and gypsum/mortar products and coatings and paints. The database also contains several ready-to-use building components such as windows with different dimensions and frame types. These windows are based on a generic, parameterised window model that is capable of "assembling" windows by adjusting parameters. Such a window model allows for the efficient generation of additional windows, if required.

As stated above, the life cycle inventories of construction materials are – similar to the underlying construction materials themselves – set up in order to meet a functional demand within a building or other construction and therefore life cycle analyses in the construction sector must consider the intended function. At the LBP-GaBi (now IABP-GaBi) and Sphera working group, a generic building model has been developed in order to meet the demand for analyzing construction materials, as well as construction elements and entire buildings, within the respective context. This building model served as the methodological basis for the life cycle analysis of the European residential buildings stock and, since then, has constantly been undergoing further development in order to meet the needs of building planners, architects and engineers to assess the life cycle performance of existing or planned buildings. The building model contains not only the construction and frame of the building, but also heating, cooling and technical appliances.

One special feature in the construction sector is the use of a ‘recycling potential.’ The recycling potential quantifies the environmental burdens that can be avoided by the use of recycled materials in comparison to the production of new materials.

EN 15804

In the extension database for construction, EN15804 (“Sustainability of construction works – Environmental product declarations – Core rules for the product category of construction products”) compatible datasets are available. The standard divides the life cycle of a building in life cycle stages and modules. Within the database for construction, each dataset is modelled, grouped and marked in accordance with the latest EN 15804+A2 (2019) methodology and modularity. The datasets can be used to model the whole life cycle of a building.

The EN 15804 methodology divides the life cycle of a building into the following stages:

- 1) Product stage,
- 2) Construction process stag,
- 3) Use stage,
- 4) End of life stage and
- 5) Benefits and loads beyond the system boundary.

Each of those life cycle stages is further broken down into more detailed stages in the product life cycle, called modules (for example product stage in modules A1, A2, and A3). The modules are continuously numbered within the life cycle stages using a capital letter and a number.

The nomenclature system for the single life cycle modules is illustrated below.

Production			Installation		Use stage							End-of-Life				Next product system
Raw material supply (extraction, processing, recycled material)	Transport to manufacturer	Manufacturing	Transport to building site	Installation into building	Use / application	Maintenance	Repair	Replacement	Refurbishment	Operational energy use	Operational water use	Deconstruction / demolition	Transport to EoL	Waste processing for reuse, recovery or recycling	Disposal	Reuse, recovery or recycling potential
A1	A2	A3	A4	A5	B1	B2	B3	B4	B5	B6	B7	C1	C2	C3	C4	D

Figure 4-11: Life cycle stage modules according to EN 15804+A2 (2019)

All construction products and materials shall declare modules A1-A3, modules C1-C4 and module D. Exempt from this requirement are listed in EN 15804+A2.

The product stage is an information module that must be contained in each EPD and it includes:

- A1, raw material extraction and processing, processing of secondary material input (e.g., recycling processes),
- A2, transport to the manufacturer,
- A3, manufacturing; including provision of all materials, products and energy, packaging processing and its transport, as well as waste processing up to the end-of waste state or disposal of final residues during the product stage.

Please note: in the GaBi Construction extension database, modules A1-A3 are aggregated.

The construction stage comprises:

- A4, transport to the construction site;
- A5, installation in the building; including provision of all materials, products and energy, as well as waste processing up to the end-of-waste state or disposal of final residues during the construction stage.

These information modules also include all impacts and aspects related to any losses during this construction stage (i.e., production, transport, and waste processing and disposal of the lost products and materials).

The use stage, related to the building fabric includes:

- B1, use or application of the installed product;
- B2, maintenance;
- B3, repair;

- B4, replacement;
- B5, refurbishment; including provision and transport of all materials, products and related energy and water use, as well as waste processing up to the end-of-waste state or disposal of final residues during this part of the use stage.

These information modules also include all impacts and aspects related to the losses during this part of the use stage (i.e., production, transport, and waste processing and disposal of the lost products and materials).

The use stage related to the operation of the building includes:

- B6, operational energy use (e.g., operation of heating system and other building related installed services);
- B7, operational water use;

These information modules include provision and transport of all materials, products, as well as energy and water provisions, waste processing up to the end-of-waste state or disposal of final residues during this part of the use stage.

The end-of-life stage starts when the construction product is replaced, dismantled or deconstructed from the building or construction works and does not provide any further function. It can also start at the end-of-life of the building, depending on the choice of the product's end-of-life scenario. This stage includes:

- C1, de-construction, demolition;
- C2, transport to waste processing;
- C3, waste processing for reuse, recovery and/or recycling;
- C4, disposal; including provision and all transports, provision of all materials, products and related energy and water use.

Module D includes any declared benefits and loads from net flows leaving the product system that have not been allocated as co-products and that have passed the end-of-waste state in the form of reuse, recovery and/or recycling potentials.

In GaBi the impact categories for EN 15804 2014 are integrated as EN 15804+A1 and for EN 15804 2019 as EN 15804+A2.

EN 15804+A2

The new standard EN 15804 2019 is used to calculate environmental indicators for Environmental Product Declaration (EPDs). This amended standard now requires users to work with the EF/ILCD elementary flow list and impact methodologies EF 3.0 from the European Commission <https://eplca.jrc.ec.europa.eu/LCDN/developerEF.xhtml>. The specific characterization factors are identical with the Environmental Footprint 3.0 with the following

notable exception regarding the declaration of CO₂ uptake from biomass which is defined in [EN 15804 2019]:

Uptake of biogenic CO₂ in biomass (excluding biomass of native forests) is characterised in the LCIA as -1 kg CO₂ eq./kg CO₂ when entering the product system and with +1 kg CO₂ eq./kg CO₂ of biogenic carbon when leaving the product system.

When declaring the following impact categories information on uncertainties as defined in [EN 15804 2019] are required for the EPD documentation as these results are high in uncertainty or as there is limited experience with the respective indicators.

- Abiotic depletion potential for non-fossil resources (ADP minerals & metals)
- Abiotic depletion potential for fossil resources (ADP fossil)
- Water (user) deprivation potential, deprivation-weighted water consumption (WDP)
- Potential Comparative Toxic Unit for ecosystems (ETP fw)
- Potential Comparative Toxic Unit for humans (HTP c)
- Potential Comparative Toxic Unit for humans (HTP nc)
- Potential Soil quality index (SQP)

EN 15804+A1

The previous version of the standard EN 15804+A1 can still be served also with the latest GaBi data; it requires the declaration of the following impact categories:

The list below shows the 24 environmental indicators used in EN 15804 conformant EPD. There are seven environmental impact indicators, ten resource indicators, three waste indicators, and four output flow indicators.

Environmental Impact Indicators

- Global Warming Potential (GWP)
- Ozone Depletion Potential (ODP)
- Acidification potential (AP)
- Eutrophication potential (EP)
- Formation potential of tropospheric ozone (POCP)
- Abiotic depletion potential for non-fossil resources (ADP elements)
- Abiotic depletion potential for fossil resources (ADP fossil fuels)

Resource Use Indicators

- Use of renewable primary energy excluding renewable primary energy resources used as raw materials
- Use of renewable primary energy resources used as raw materials
- Total use of renewable primary energy resources (primary energy and primary energy resources used as raw materials)

- Use of non-renewable primary energy excluding non-renewable primary energy resources used as raw materials
- Use of non-renewable primary energy resources used as raw materials
- Total use of non-renewable primary energy resources (primary energy and primary energy resources used as raw materials)
- Use of secondary material
- Use of renewable secondary fuels
- Use of non-renewable secondary fuels
- Use of net freshwater

Waste Category Indicators

- Hazardous waste deposited
- Non-hazardous waste disposed
- Radioactive waste disposed

Output Flow Indicators

- Components for re-use
- Materials for recycling
- Materials for energy recovery
- Exported energy

EN 15804 and CML impact list

The following chapter informs about the relation of Impact Categories required by EN 15804 to the frequently updated CML method collection of Impact categories (CML = Institute of Environmental Sciences Faculty of Science University of Leiden, Netherlands). Concerning the required impact categories, the standard 15804 in its current version refers to the baseline versions of the CML collection of impact methods in the version Oct 2012.

The CML list is a dynamic list, which is frequently maintained, bug fixed, enlarged and updated. Only the most recent list is publicly available for download at the CML website. The version available for download at the moment is version April 2015. This means the list of impact values given in the standard EN 15804 cannot be reproduced by the user with CML information given on the website of CML.

Further, the CML (baseline method) list is not to be understood as all encompassing. CML invites and inspires users to produce further characterization factors for still “missing” emissions and interventions according to the methods documented and explained in background document downloadable from the CML homepage.

CML provides characterization factors for emissions as far as it was possible to pre-calculate in the goal and scope of CML. It remains in the responsibility of the user to check, if emissions

occur that are potentially impact relevant and are not pre-characterised. In this case, the user has the responsibility to

- either add a characterization factor for the respective flow(s) by himself or
- to use another characterized flow representing the intervention adequately or
- To interpret the results in the light of this missing impact factor accordingly.

In the GaBi software we apply the characterization factors of the CML baseline method and – to the comfort of GaBi users – already pre-characterise known important emission flows, which came across repeatedly in LCA work and which potentially have a known impact, but are not yet characterised according the respective CML method.

This chapter aims to transparently inform users and reviewers about the virtual differences between the cited versions of CML in the standard EN 15804 (standardisation document), the most up to date version publicly available at CML (maintained method collection on webpage) and the respective GaBi implementation and additional pre-characterization in the latest GaBi Version (maintained LCA solution).

Recommendation

We recommend generally – and not exclusively for EN 15804 – to use the latest versions of methods (like for CML the Apr. 2015 version), wherever allowed by a standard. If a method (collection) like CML is maintained, the likelihood of errors is smaller and the amount of characterization factors available is likely to be larger and relevant gaps in characterization factors likely to be smaller in the newest version compared to predecessor versions.

Requirements in EN 15804

By using the CML Apr. 2015 version the user lives up with the requirements of EN 15804. The differences in CML versions are either nil, negligible or explainable.

If there are significant differences in a result using the EN 15804 standard list compared to a result using the GaBi/CML 2015 list – assuming of course that the user did model correct and consistent – the reason can be either:

- a) a difference between CML 2012 and 2015 (CML added or modified characterization factors) or
- b) a difference between default CML 2015 list and Sphera enlarged characterization factor list 2015 (Sphera added characterization factors for flows that definitely need to be characterized to match consistency)

This might be the case due to:

- 1) a mistake in any of the above implementation lists a) or b) or
- 2) due to an insufficient list of characterization factors in EN 15804

Due to the constant maintenance of CML characterization factors and GaBi characterization factor implementation, the likelihood of 2) is higher.

Distinctions in the Characterization factors

Background

To put the “difference” into perspective: The difference of the (older) CML version 2012 / (static) EN 15804 list and the (newer) CML 2013 / (adapted) GaBi list is small. Additional CML characterization factors were only added to GaBi flows, if these are relevant in LCI as well as significant for a potentially consistent impact result (see above).

There are almost 5000 characterization factors given in CML. These are 1:1 applied in GaBi. Additionally, about 50 (significant) CF for (relevant) emission flows were added in GaBi to the CML 2013 list.

So, per se GaBi and EN 15804 have a 99% fit, plus another 1% added valuable information.

If this 1% difference leads to a significant difference ($\gg 1\%$) in a result comparison EN 15804/CML 2012 vs. GaBi/CML 2013, the reason must be (according to ISO 14040/14044, where EN 15804 is tied to) evaluated anyway. The fact that a reviewer or user would not recognize (and virtually cut-off) the difference by using the (static) EN 15804 list 1:1 in GaBi, is no justification according to ISO (see chapter 4.2.3.3.3, ISO 14044). Environmental significance has to be taken into account and must be individually justified by the user/reviewer himself.

As a summary: The difference EN 15804/CML 2012 vs. GaBi/CML 2013 is per se small and if it gets significant, the reason is to be determined, and most likely the GaBi/CML 2013 result is the ISO conform one.

Details of added information EN 15804/CML 2012 → GaBi/CML 2013

The following table provides information about added emissions characterization factors to CML 2012, to live up with the latest CML versions and the requirements in ISO 14044.

Additional CML characterisation factors in comparison to list EN 15804 annex C			
Acidification			
Problem oriented approach: baseline (CML, 2001), acidification AP (incl. fate, average Europe total, A&B, Huijbregts, 1999)			
Flow	kg SO ₂ - Equiv.	added by	Calculation remark
1 Sulphur trioxide [Inorganic emissions to air]	0,960	CML	new factor
2 Sulphuric acid [Inorganic emissions to air]	0,784	CML	new factor
3 Sulphuric acid [Inorganic emissions to agricultural soil]	0,784	PE	AP, consistent for all compartments
4 Sulphuric acid [Inorganic emissions to fresh water]	0,784	PE	AP, consistent for all compartments
5 Sulphuric acid [Inorganic emissions to industrial soil]	0,784	PE	AP, consistent for all compartments
6 Sulphuric acid [Inorganic emissions to sea water]	0,784	PE	AP, consistent for all compartments
7 Ammonium [Inorganic emissions to air]	3,2	PE	AP, 2 x NH ₃ value due to 2 x H ⁺ release potential
8 Ammonium nitrate [Inorganic emissions to air]	0,720	PE	AP, stoichometr. adaption of NH ₄ ⁺ value (x 18/80)
9 Sulphur oxides [Inorganic emissions to air]	1,2	PE	AP, characterised as SO ₂
10 Hydrogen chloride [Inorganic emissions to agricultural soil]	0,749	PE	AP, see CML (Hauschild & Wenzel (1998), excl. fate) *
11 Hydrogen chloride [Inorganic emissions to air]	0,749	PE	AP, see CML (Hauschild & Wenzel (1998), excl. fate) *
12 Hydrogen chloride [Inorganic emissions to fresh water]	0,749	PE	AP, see CML (Hauschild & Wenzel (1998), excl. fate) *
13 Hydrogen chloride [Inorganic emissions to industrial soil]	0,749	PE	AP, see CML (Hauschild & Wenzel (1998), excl. fate) *
14 Hydrogen chloride [Inorganic emissions to sea water]	0,749	PE	AP, see CML (Hauschild & Wenzel (1998), excl. fate) *
15 Hydrogen bromine (hydrobromic acid) [Inorganic emissions to air]	0,328	PE	AP, see CML (Hauschild & Wenzel (1998), excl. fate) *
16 Hydrogen fluoride (hydrofluoric acid) [Inorganic emissions to agricultural soil]	1,36	PE	AP, see CML (Hauschild & Wenzel (1998), excl. fate) *
17 Hydrogen fluoride (hydrofluoric acid) [Inorganic emissions to fresh water]	1,36	PE	AP, see CML (Hauschild & Wenzel (1998), excl. fate) *
18 Hydrogen fluoride (hydrofluoric acid) [Inorganic emissions to industrial soil]	1,36	PE	AP, see CML (Hauschild & Wenzel (1998), excl. fate) *
19 Hydrogen fluoride (hydrofluoric acid) [Inorganic emissions to sea water]	1,36	PE	AP, see CML (Hauschild & Wenzel (1998), excl. fate) *
20 Hydrogen fluoride [Inorganic emissions to air]	1,36	PE	AP, see CML (Hauschild & Wenzel (1998), excl. fate) *
21 Hydrogen sulphide [Inorganic emissions to agricultural soil]	1,6	PE	AP, see CML (Hauschild & Wenzel (1998), excl. fate) *
22 Hydrogen sulphide [Inorganic emissions to air]	1,6	PE	AP, see CML (Hauschild & Wenzel (1998), excl. fate) *
23 Hydrogen sulphide [Inorganic emissions to fresh water]	1,6	PE	AP, see CML (Hauschild & Wenzel (1998), excl. fate) *
24 Hydrogen sulphide [ecoinvent long-term to fresh water]	1,6	PE	AP, see CML (Hauschild & Wenzel (1998), excl. fate) *
25 Hydrogen sulphide [Inorganic emissions to industrial soil]	1,6	PE	AP, see CML (Hauschild & Wenzel (1998), excl. fate) *
26 Hydrogen sulphide [Inorganic emissions to sea water]	1,6	PE	AP, see CML (Hauschild & Wenzel (1998), excl. fate) *
27 Nitric acid [Inorganic emissions to agricultural soil]	0,434	PE	AP, see CML (Hauschild & Wenzel (1998), excl. fate) *
28 Nitric acid [Inorganic emissions to air]	0,434	PE	AP, see CML (Hauschild & Wenzel (1998), excl. fate) *
29 Nitric acid [Inorganic emissions to fresh water]	0,434	PE	AP, see CML (Hauschild & Wenzel (1998), excl. fate) *
30 Nitric acid [Inorganic emissions to industrial soil]	0,434	PE	AP, see CML (Hauschild & Wenzel (1998), excl. fate) *
31 Nitric acid [Inorganic emissions to sea water]	0,434	PE	AP, see CML (Hauschild & Wenzel (1998), excl. fate) *
32 Phosphoric acid [Inorganic emissions to agricultural soil]	0,834	PE	AP, see CML (Hauschild & Wenzel (1998), excl. fate) *
33 Phosphoric acid [Inorganic emissions to air]	0,834	PE	AP, see CML (Hauschild & Wenzel (1998), excl. fate) *
34 Phosphoric acid [Inorganic emissions to fresh water]	0,834	PE	AP, see CML (Hauschild & Wenzel (1998), excl. fate) *
35 Phosphoric acid [Inorganic emissions to industrial soil]	0,834	PE	AP, see CML (Hauschild & Wenzel (1998), excl. fate) *
36 Phosphoric acid [Inorganic emissions to sea water]	0,834	PE	AP, see CML (Hauschild & Wenzel (1998), excl. fate) *
Eutrophication			
Problem oriented approach: baseline (CML, 2001), eutrophication EP (fate not incl., Heijungs et al. 1992)			
Flow	kg PO ₄ - Equiv.	added by	Calculation remark
37 Octane [Hydrocarbons to sea water]	0,077	PE	Stoichiometric relation to COD impact
38 Octane [Hydrocarbons to fresh water]	0,077	PE	Stoichiometric relation to COD impact
39 Oil (unspecified) [Hydrocarbons to fresh water]	0,077	PE	Stoichiometric relation to COD impact, Oil = C ₁₀ H ₂₂
40 Oil (unspecified) [Hydrocarbons to sea water]	0,077	PE	Stoichiometric relation to COD impact, Oil = C ₁₀ H ₂₂
41 Organic compounds (dissolved) [Organic emissions to fresh water]	0,023	PE	Stoichiometric relation to COD impact, assum. CH ₂ O
42 Organic compounds (unspecified) [Organic emissions to fresh water]	0,023	PE	Stoichiometric relation to COD impact, assum. CH ₂ O
43 Organic compounds (dissolved) [Organic emissions to sea water]	0,023	PE	Stoichiometric relation to COD impact, assum. CH ₂ O
44 Organic compounds (unspecified) [Organic emissions to sea water]	0,023	PE	Stoichiometric relation to COD impact, assum. CH ₂ O
45 Sodium nitrate [Inorganic emissions to fresh water]	0,073	PE	as nitrate
46 Sodium nitrate (NaNO ₃) [Inorganic emissions to sea water]	0,073	PE	as nitrate
47 Total dissolved organic bounded carbon [Analytical measures to fresh water]	0,059	PE	Stoichiometric COD assuming C ₆ H ₁₁ O
48 Total dissolved organic bounded carbon [Analytical measures to sea water]	0,059	PE	Stoichiometric COD assuming C ₆ H ₁₁ O
49 Total organic bounded carbon [Analytical measures to sea water]	0,059	PE	Stoichiometric COD assuming C ₆ H ₁₁ O
50 Total organic bounded carbon [Analytical measures to fresh water]	0,059	PE	Stoichiometric COD assuming C ₆ H ₁₁ O
51 Xylene (isomers; dimethyl benzene) [Hydrocarbons to fresh water]	0,070	PE	Stoichiometric relation to COD impact
52 Xylene (isomers; dimethyl benzene) [Hydrocarbons to sea water]	0,070	PE	Stoichiometric relation to COD impact
53 Xylene (meta-Xylene; 1,3-Dimethylbenzene) [Hydrocarbons to fresh water]	0,070	PE	Stoichiometric relation to COD impact
54 Xylene (meta-Xylene; 1,3-Dimethylbenzene) [Hydrocarbons to sea water]	0,070	PE	Stoichiometric relation to COD impact
55 Xylene (ortho-Xylene; 1,2-Dimethylbenzene) [Hydrocarbons to sea water]	0,070	PE	Stoichiometric relation to COD impact
56 Xylene (ortho-Xylene; 1,2-Dimethylbenzene) [Hydrocarbons to fresh water]	0,070	PE	Stoichiometric relation to COD impact
57 Xylene (para-Xylene; 1,4-Dimethylbenzene) [Hydrocarbons to fresh water]	0,070	PE	Stoichiometric relation to COD impact
58 Xylene (para-Xylene; 1,4-Dimethylbenzene) [Hydrocarbons to sea water]	0,070	PE	Stoichiometric relation to COD impact

* adapted by 0,85 to include fate consistently

Application of existing (unspecific) characterization factors to specific fossil resource flows

For ADP fossil CML only gives four value for the four main fossil resources in relation to a chosen mean calorific value. As the characteristics of fossil resources are strongly depending on the kind and location of the deposit, characteristics of fossil resources like the calorific value strongly varies.

Users and customers of GaBi ever since report or search for specific fossil resources with specific characteristics of specific deposits. Therefore, GaBi ever since has additionally many deposit and country specific fossil resources. The adoption of the characterization factor is straight forward, as the reference is the calorific value. So the following list is just the consequent and consistent application of existing (unspecific) characterization factors to specific resource flows of the same nature.

ADP f		
Problem oriented approach: baseline (CML, 2001), ADP fossil fuels (Oers et al., 2001)		
Flow	unit	according to calorific value
Oil sand (10% bitumen) (in MJ) [Crude oil (resource)]	MJ	1
Oil sand (100% bitumen) (in MJ) [Crude oil (resource)]	MJ	1
Peat (in kg) [Peat (resource)]	kg	8,4
Peat (in MJ) [Peat (resource)]	MJ	1
Peat ecoinvent [Non renewable resources]	kg	8,74
Pit gas (in kg) [Natural gas (resource)]	kg	40,35
Pit gas ecoinvent [Natural gas (resource)]	Nm3	35,86
Pit Methane (in kg) [Natural gas (resource)]	kg	49,84
Pit Methane (in MJ) [Natural gas (resource)]	MJ	1
Raw hardcoal [Hard coal (resource)]	kg	18
Raw lignite [Lignite (resource)]	kg	7,999999983
Shale gas (in MJ) [Natural gas (resource)]	MJ	1
Tight gas (in MJ) [Natural gas (resource)]	MJ	1

ADP f		
Problem oriented approach: baseline (CML, 2001), ADP fossil fuels (Oers et al., 2001)		
Flow	unit	according to calorific value
Coalbed methane (in MJ) [Natural gas (resource)]	MJ	1
Crude oil (lSI) [Crude oil (resource)]	kg	41
Crude oil (in kg) [Crude oil (resource)]	kg	42,33
Crude oil (in MJ) [Crude oil (resource)]	MJ	1
Crude oil Algeria [Crude oil (resource)]	kg	43,52
Crude oil Angola [Crude oil (resource)]	kg	42,59
Crude oil Argentina [Crude oil (resource)]	kg	42,53
Crude oil Australia [Crude oil (resource)]	kg	43,53
Crude oil Austria [Crude oil (resource)]	kg	42,74
Crude oil Bolivia [Crude oil (resource)]	kg	43,31
Crude oil Brazil [Crude oil (resource)]	kg	42,5
Crude oil Brunei [Crude oil (resource)]	kg	42,45
Crude oil Bulgaria [Crude oil (resource)]	kg	42,05
Crude oil Cameroon [Crude oil (resource)]	kg	42,26
Crude oil Canada [Crude oil (resource)]	kg	41,89
Crude oil Chile [Crude oil (resource)]	kg	42,78
Crude oil China [Crude oil (resource)]	kg	42,84
Crude oil CIS [Crude oil (resource)]	kg	42,15
Crude oil Colombia [Crude oil (resource)]	kg	42,05
Crude oil Czech Republic [Crude oil (resource)]	kg	41,53
Crude oil Denmark [Crude oil (resource)]	kg	42,08
Crude oil ecoinvent [Crude oil (resource)]	kg	43,19
Crude oil Ecuador [Crude oil (resource)]	kg	42,09
Crude oil Egypt [Crude oil (resource)]	kg	42,39
Crude oil Equatorial Guinea [Crude oil (resource)]	kg	42,41
Crude oil France [Crude oil (resource)]	kg	42,43
Crude oil Gabon [Crude oil (resource)]	kg	42,41
Crude oil Germany [Crude oil (resource)]	kg	42,83
Crude oil Great Britain [Crude oil (resource)]	kg	42,33
Crude oil Greece [Crude oil (resource)]	kg	42,26
Crude oil Hungary [Crude oil (resource)]	kg	41,22
Crude oil India [Crude oil (resource)]	kg	41,41
Crude oil Indonesia [Crude oil (resource)]	kg	40,94
Crude oil Iran [Crude oil (resource)]	kg	42,29
Crude oil Iraq [Crude oil (resource)]	kg	42,54
Crude oil Ireland [Crude oil (resource)]	kg	42,33
Crude oil Italy [Crude oil (resource)]	kg	44,33
Crude oil Japan [Crude oil (resource)]	kg	42,8
Crude oil Kuwait [Crude oil (resource)]	kg	42,38
Crude oil Libya [Crude oil (resource)]	kg	43,74
Crude oil Malaysia [Crude oil (resource)]	kg	42,92
Crude oil Mexico [Crude oil (resource)]	kg	41,28
Crude oil Myanmar [Crude oil (resource)]	kg	42,05
Crude oil Netherlands [Crude oil (resource)]	kg	43,96
Crude oil New Zealand [Crude oil (resource)]	kg	39,28
Crude oil Nigeria [Crude oil (resource)]	kg	42,78
Crude oil Norway [Crude oil (resource)]	kg	42,83
Crude oil Oman [Crude oil (resource)]	kg	42,42
Crude oil Poland [Crude oil (resource)]	kg	42,57
Crude oil Qatar [Crude oil (resource)]	kg	43,4
Crude oil Romania [Crude oil (resource)]	kg	42,78
Crude oil Saudi Arabia [Crude oil (resource)]	kg	42,45
Crude oil Slovakia [Crude oil (resource)]	kg	41,53
Crude oil South Africa [Crude oil (resource)]	kg	43,06
Crude oil Spain [Crude oil (resource)]	kg	42,78
Crude oil Syria [Crude oil (resource)]	kg	44,27
Crude oil Taiwan [Crude oil (resource)]	kg	40,93
Crude oil Thailand [Crude oil (resource)]	kg	43,03
Crude oil Trinidad and Tobago [Crude oil (resource)]	kg	42,07
Crude oil Tunisia [Crude oil (resource)]	kg	43,04
Crude oil Turkey [Crude oil (resource)]	kg	42,43
Crude oil United Arab Emirates [Crude oil (resource)]	kg	43,11
Crude oil USA [Crude oil (resource)]	kg	41,94
Crude oil Venezuela [Crude oil (resource)]	kg	42,4

ADP f		
Problem oriented approach: baseline (CML, 2001), ADP fossil fuels (Oers et al., 2001)		
Flow	unit	according to calorific value
Hard coal (IISI) [Hard coal (resource)]	kg	30,5
Hard coal (in kg) [Hard coal (resource)]	kg	26,31
Hard coal (in MJ) [Hard coal (resource)]	MJ	1
Hard coal Australia [Hard coal (resource)]	kg	27,47
Hard coal Belgium [Hard coal (resource)]	kg	17,6
Hard coal Bosnia and Herzegovina [Hard coal (resource)]	kg	25,42
Hard coal Brazil [Hard coal (resource)]	kg	25,09
Hard coal Canada [Hard coal (resource)]	kg	27,36
Hard coal Chile [Hard coal (resource)]	kg	25,31
Hard coal China [Hard coal (resource)]	kg	25,4
Hard coal CIS [Hard coal (resource)]	kg	27,12
Hard coal Colombia [Hard coal (resource)]	kg	26,27
Hard coal Czech Republic [Hard coal (resource)]	kg	23,63
Hard coal ecoinvent [Hard coal (resource)]	kg	18,37
Hard coal France [Hard coal (resource)]	kg	26,81
Hard coal Germany [Hard coal (resource)]	kg	30,2
Hard coal Great Britain [Hard coal (resource)]	kg	24,75
Hard coal India [Hard coal (resource)]	kg	26,88
Hard coal Indonesia [Hard coal (resource)]	kg	23,69
Hard coal Italy [Hard coal (resource)]	kg	25,42
Hard coal Japan [Hard coal (resource)]	kg	22,31
Hard coal Malaysia [Hard coal (resource)]	kg	25,89
Hard coal Mexico [Hard coal (resource)]	kg	26,41
Hard coal New Zealand [Hard coal (resource)]	kg	27,47
Hard coal Poland [Hard coal (resource)]	kg	24
Hard coal Portugal [Hard coal (resource)]	kg	28,25
Hard coal South Africa [Hard coal (resource)]	kg	26
Hard coal South Korea [Hard coal (resource)]	kg	25,89
Hard coal Spain [Hard coal (resource)]	kg	30,62
Hard coal Turkey [Hard coal (resource)]	kg	27,42
Hard coal USA [Hard coal (resource)]	kg	27,7
Hard coal Venezuela [Hard coal (resource)]	kg	28,4
Hard coal Vietnam [Hard coal (resource)]	kg	25,89

ADP f		
Problem oriented approach: baseline (CML, 2001), ADP fossil fuels (Oers et al., 2001)		
Flow	unit	according to calorific value
Lignite (in kg) [Lignite (resource)]	kg	11,88
Lignite (in MJ) [Lignite (resource)]	MJ	1
Lignite Australia [Lignite (resource)]	kg	9,29
Lignite Austria [Lignite (resource)]	kg	10
Lignite Bosnia and Herzegovina [Lignite (resource)]	kg	7,63
Lignite Bulgaria [Lignite (resource)]	kg	10,85
Lignite Canada [Lignite (resource)]	kg	14,25
Lignite CIS [Lignite (resource)]	kg	13,95
Lignite Czech Republic [Lignite (resource)]	kg	11,14
Lignite ecoinvent [Lignite (resource)]	kg	9,26
Lignite France [Lignite (resource)]	kg	7,8
Lignite Germany [Lignite (resource)]	kg	9,82
Lignite Germany (Central Germany) [Lignite (resource)]	kg	10,1
Lignite Germany (Lausitz) [Lignite (resource)]	kg	9,48
Lignite Germany (Rheinisch) [Lignite (resource)]	kg	9,97
Lignite Greece [Lignite (resource)]	kg	6,7
Lignite Hungary [Lignite (resource)]	kg	7,5
Lignite India [Lignite (resource)]	kg	11,63
Lignite Macedonia [Lignite (resource)]	kg	7,63
Lignite Poland [Lignite (resource)]	kg	8,85
Lignite Romania [Lignite (resource)]	kg	7,63
Lignite Serbia [Lignite (resource)]	kg	7,63
Lignite Slovakia [Lignite (resource)]	kg	11,15
Lignite Slovenia [Lignite (resource)]	kg	9,8
Lignite Spain [Lignite (resource)]	kg	7,84
Lignite Thailand [Lignite (resource)]	kg	11,63
Lignite Turkey [Lignite (resource)]	kg	10,98
Lignite USA [Lignite (resource)]	kg	14,02
Metallurgical coal [Non renewable resources]	kg	26,31

ADP f		
Problem oriented approach: baseline (CML, 2001), ADP fossil fuels (Oers et al., 2001)		
Flow	unit	according to calorific value
Natural gas (IISI) [Natural gas (resource)]	kg	46
Natural gas (in kg) [Natural gas (resource)]	kg	44,08
Natural gas (in MJ) [Natural gas (resource)]	MJ	1
Natural gas Algeria [Natural gas (resource)]	kg	44,54
Natural gas Angola [Natural gas (resource)]	kg	43,85
Natural gas Argentina [Natural gas (resource)]	kg	42,30
Natural gas Australia [Natural gas (resource)]	kg	40,37
Natural gas Austria [Natural gas (resource)]	kg	45,24
Natural gas Bolivia [Natural gas (resource)]	kg	42,30
Natural gas Brazil [Natural gas (resource)]	kg	41,32
Natural gas Brunei [Natural gas (resource)]	kg	46,01
Natural gas Bulgaria [Natural gas (resource)]	kg	42,76
Natural gas Cameroon [Natural gas (resource)]	kg	43,85
Natural gas Canada [Natural gas (resource)]	kg	45,35
Natural gas Chile [Natural gas (resource)]	kg	43,28
Natural gas China [Natural gas (resource)]	kg	46,22
Natural gas CIS [Natural gas (resource)]	kg	36,03
Natural gas Colombia [Natural gas (resource)]	kg	37,80
Natural gas Czech Republic [Natural gas (resource)]	kg	37,84
Natural gas Denmark [Natural gas (resource)]	kg	47,16
Natural gas ecoinvent [Natural gas (resource)]	Nm3	34,50
Natural gas Ecuador [Natural gas (resource)]	kg	48,29
Natural gas Egypt [Natural gas (resource)]	kg	43,85
Natural gas France [Natural gas (resource)]	kg	40,20
Natural gas Gabon [Natural gas (resource)]	kg	43,85
Natural gas Germany [Natural gas (resource)]	kg	43,32
Natural gas Great Britain [Natural gas (resource)]	kg	47,21
Natural gas Greece [Natural gas (resource)]	kg	47,64
Natural gas Hungary [Natural gas (resource)]	kg	38,85
Natural gas India [Natural gas (resource)]	kg	47,66
Natural gas Indonesia [Natural gas (resource)]	kg	44,83
Natural gas Iran [Natural gas (resource)]	kg	44,79
Natural gas Iraq [Natural gas (resource)]	kg	42,83
Natural gas Ireland [Natural gas (resource)]	kg	42,78
Natural gas Italy [Natural gas (resource)]	kg	41,02
Natural gas Japan [Natural gas (resource)]	kg	44,47
Natural gas Kuwait [Natural gas (resource)]	kg	42,83
Natural gas Libya [Natural gas (resource)]	kg	43,85
Natural gas Malaysia [Natural gas (resource)]	kg	39,22
Natural gas Mexico [Natural gas (resource)]	kg	46,36
Natural gas Myanmar [Natural gas (resource)]	kg	44,12
Natural gas Netherlands [Natural gas (resource)]	kg	38,13
Natural gas New Zealand [Natural gas (resource)]	kg	37,41
Natural gas Nigeria [Natural gas (resource)]	kg	43,85
Natural gas Norway [Natural gas (resource)]	kg	47,13
Natural gas Oman [Natural gas (resource)]	kg	42,83
Natural gas Poland [Natural gas (resource)]	kg	43,09999911
Natural gas Qatar [Natural gas (resource)]	kg	42,83
Natural gas Romania [Natural gas (resource)]	kg	43,33
Natural gas Saudi Arabia [Natural gas (resource)]	kg	42,83
Natural gas Slovakia [Natural gas (resource)]	kg	45,02
Natural gas South Africa [Natural gas (resource)]	kg	43,85
Natural gas Spain [Natural gas (resource)]	kg	44,85
Natural gas Syria [Natural gas (resource)]	kg	39,83
Natural gas Taiwan [Natural gas (resource)]	kg	40,51
Natural gas Thailand [Natural gas (resource)]	kg	39,56
Natural gas Trinidad and Tobago [Natural gas (resource)]	kg	42,32
Natural gas Tunisia [Natural gas (resource)]	kg	46,19
Natural gas Turkey [Natural gas (resource)]	kg	45,30
Natural gas United Arab Emirates [Natural gas (resource)]	kg	41,26
Natural gas USA [Natural gas (resource)]	kg	38,99
Natural gas Venezuela [Natural gas (resource)]	kg	46,48

Application of existing (unspecific) characterization factors to specific mineral resource flows

For ADP elements, the same logic applies than for ADP fossil. CML only gives four values for the (unspecific) resources in relation to the element. As the characteristics of mineral resources are strongly depending on the kind and location of the deposit and the ore characteristics, the element value must be applied to the real ores existing in the earth crust as well.

Users and customers of GaBi ever since report or search for specific mineral ore resources with specific characteristics of specific deposits. Therefore, GaBi ever since has additionally many deposit specific ore resources. The adoption of the characterization factor is straight forward, as the reference is the element. So the following list is just the consequent and consistent application of existing (unspecific) characterization factors to specific resource flows of the same nature.

ADP e		
Problem oriented approach: baseline (CML, 2001), ADPelements (Oers et al. 2001)		
Flow	Unit	according to element content in Sb-Equivalent
Aluminium [Non renewable elements]	kg	1,09E-09
Anhydrite (Rock) [Non renewable resources]	kg	0,00E+00
Antimonite [Non renewable resources]	kg	7,18E-01
Antimony [Non renewable elements]	kg	1,00E+00
Antimony - gold - ore (0.09%) [Non renewable resources]	kg	9,22E-03
Argon [Non renewable elements]	kg	0,00E+00
Arsenic [Non renewable elements]	kg	2,97E-03
Barium [Non renewable elements]	kg	6,04E-06
Barium sulphate [Non renewable resources]	kg	3,00E-05
Basalt [Non renewable resources]	kg	0,00E+00
Bauxite [Non renewable resources]	kg	3,79E-10
Bentonit clay [Non renewable resources]	kg	0,00E+00
Bentonite [Non renewable resources]	kg	0,00E+00
Beryllium [Non renewable elements]	kg	1,26E-05
Bismuth [Non renewable elements]	kg	4,11E-02
Borax [Non renewable resources]	kg	5,38E-04
Boron [Non renewable elements]	kg	4,27E-03
Bromine [Non renewable elements]	kg	4,39E-03
Cadmium [Non renewable elements]	kg	1,57E-01
Cadmium ore [Non renewable resources]	kg	1,57E-03
Calcium [Non renewable elements]	kg	0,00E+00
Calcium chloride [Non renewable resources]	kg	1,74E-05
Chalk (Calciumcarbonate) [Non renewable resources]	kg	0,00E+00
Chlorine [Non renewable elements]	kg	2,71E-05
Chromium [Non renewable elements]	kg	4,43E-04
Chromium ore (39%) [Non renewable resources]	kg	1,73E-04
Chromium ore (Cr2O3 30%) [Non renewable resources]	kg	8,85E-05
Chromium ore (Cr2O3 40%) [Non renewable resources]	kg	1,33E-04
Chrysotile [Non renewable resources]	kg	5,49E-10
Cinnabar [Non renewable resources]	kg	7,96E-02
Clay [Non renewable resources]	kg	0,00E+00
Coalbed methane (in MJ) [Natural gas (resource)]	MJ	0,00E+00
Cobalt [Non renewable elements]	kg	1,57E-05
Cobalt ore (0.04%) [Non renewable resources]	kg	6,26E-09
Cobalt ore (0.067%) [Non renewable resources]	kg	1,05E-08
Colemanite ore [Non renewable resources]	kg	6,84E-04

ADP e		
Problem oriented approach: baseline (CML, 2001), ADPelements (Oers et al. 2001)		
Flow	Unit	according to element content in Sb-Equivalent
Copper [Non renewable elements]	kg	1,37E-03
Copper - Gold - Ore (1,07% Cu; 0,54 g/t Au) [Non renewable]	kg	4,27E-05
Copper - Gold - Silver - ore (0,51% Cu; 0,6 g/t Au; 1,5 g/t Ag)	kg	4,00E-05
Copper - Gold - Silver - ore (1,0% Cu; 0,4 g/t Au; 66 g/t Ag) [kg	1,13E-04
Copper - Gold - Silver - ore (1,1% Cu; 0,01 g/t Au; 2,86 g/t A	kg	1,89E-05
Copper - Gold - Silver - ore (1,13% Cu; 1,05 g/t Au; 3,72 g/t	kg	7,45E-05
Copper - Gold - Silver - ore (1,16% Cu; 0,002 g/t Au; 1,06 g/t	kg	1,72E-05
Copper - Gold - Silver - ore (1,7% Cu; 0,7 g/t Au; 3,5 g/t Ag)	kg	1,01E-04
Copper - Molybdenum - Gold - Silver - ore (1,13% Cu; 0,02%	kg	5,23E-03
Copper - Silver - ore (3,3% Cu; 5,5 g/t Ag) [Non renewable re	kg	5,16E-05
Copper ore (0.14%) [Non renewable resources]	kg	2,19E-06
Copper ore (0.2%) [Non renewable resources]	kg	2,73E-06
Copper ore (0.3%) [Non renewable resources]	kg	4,10E-06
Copper ore (1 %) [Non renewable resources]	kg	1,37E-05
Copper ore (1,13%) [Non renewable resources]	kg	1,78E-05
Copper ore (1.2%) [Non renewable resources]	kg	1,64E-05
Copper ore (1.28%) [Non renewable resources]	kg	1,75E-05
Copper ore (1.3 %) [Non renewable resources]	kg	1,75E-05
Copper ore (2%) [Non renewable resources]	kg	2,73E-05
Copper ore (4%) [Non renewable resources]	kg	5,46E-05
Copper ore (sulphidic, 1.1%) [Non renewable resources]	kg	1,54E-05
Copper, Cu 0.38%, Au 9.7E-4%, Ag 9.7E-4%, Zn 0.63%, Pb	kg	1,37E-03
Cyanite [Non renewable resources]	kg	3,67E-10
Diatomite [Non renewable resources]	kg	6,54E-12
Dolomite [Non renewable resources]	kg	2,63E-10
Feldspar (aluminium silicates) [Non renewable resources]	kg	0,00E+00
Ferro manganese [Non renewable resources]	kg	1,30E-06
Fluorine [Non renewable elements]	kg	0,00E+00
Fluorspar (calcium fluoride; fluorite) [Non renewable resource	kg	0,00E+00
Gallium [Non renewable elements]	kg	1,46E-07
Germanium [Non renewable elements]	kg	6,52E-07
Gold [Non renewable elements]	kg	5,20E+01
Gold deposit (1ppm) [Non renewable resources]	kg	5,20E-05
Granite [Non renewable resources]	kg	0,00E+00
Graphite [Non renewable resources]	kg	0,00E+00
Gravel [Non renewable resources]	kg	0,00E+00
Gypsum (natural gypsum) [Non renewable resources]	kg	3,59E-05
Heavy spar (BaSO4) [Non renewable resources]	kg	3,55E-06
Helium [Non renewable elements]	kg	0,00E+00
Helium, 0.08% in natural gas [Non renewable resources]	kg	0,00E+00
Ilmenite (titanium ore) [Non renewable resources]	kg	8,86E-09
Indium [Non renewable elements]	kg	6,89E-03
Inert rock [Non renewable resources]	kg	0,00E+00
Iodine [Non renewable elements]	kg	2,50E-02
Iron [Non renewable elements]	kg	5,24E-08
Iron ore (56,86%) [Non renewable resources]	kg	2,98E-08
Iron ore (65%) [Non renewable resources]	kg	3,41E-08

ADP e		
Problem oriented approach: baseline (CML, 2001), ADPelements (Oers et al. 2001)		
Flow	Unit	according to element content in Sb-Equivalent
Kaolin ore [Non renewable resources]	kg	2,88E-10
Kaolinite (24% in ore as mined) [Non renewable resources]	kg	2,33E-10
Kieserite (25% in ore as mined) [Non renewable resources]	kg	0,00E+00
Krypton [Non renewable elements]	kg	0,00E+00
Lava [Non renewable resources]	kg	0,00E+00
Lead [Non renewable elements]	kg	6,34E-03
Lead - Zinc - Silver - ore (5,49% Pb; 12,15% Zn; 57,4 gpt Ag)	kg	4,81E-04
Lead - zinc ore (4.6%-0.6%) [Non renewable resources]	kg	2,95E-04
Lead ore (5%) [Non renewable resources]	kg	3,17E-04
Lead, Pb 0.014%, Au 9.7E-4%, Ag 9.7E-4%, Zn 0.63%, Cu	kg	6,34E-03
Limestone (calcium carbonate) [Non renewable resources]	kg	0,00E+00
Lithium [Non renewable elements]	kg	1,15E-05
Lithium ore (3%) [Non renewable resources]	kg	3,44E-07
Magnesit (Magnesium carbonate) [Non renewable resources]	kg	5,77E-10
Magnesium [Non renewable elements]	kg	2,02E-09
Magnesium chloride leach (40%) [Non renewable resources]	kg	8,08E-06
Manganese [Non renewable elements]	kg	2,54E-06
Manganese ore [Non renewable resources]	kg	1,14E-06
Manganese ore (43%) [Non renewable resources]	kg	1,09E-06
Manganese ore (45%) [Non renewable resources]	kg	1,14E-06
Manganese ore (R.O.M.) [Non renewable resources]	kg	1,14E-06
Mercury [Non renewable elements]	kg	9,22E-02
Metamorphic stone, containing graphite [Non renewable resources]	kg	0,00E+00
Molybdenid disulfide (Mo 0.21%) [Non renewable resources]	kg	3,76E-05
Molybdenite (Mo 0,24%) [Non renewable resources]	kg	4,30E-05
Molybdenum [Non renewable elements]	kg	1,78E-02
Molybdenum ore (0,01%) [Non renewable resources]	kg	1,78E-06
Molybdenum ore (0.1%) [Non renewable resources]	kg	1,78E-05
Natural Aggregate [Non renewable resources]	kg	0,00E+00
Natural gas (in kg) [Natural gas (resource)]	kg	0,00E+00
Natural gas (in MJ) [Natural gas (resource)]	MJ	0,00E+00
Natural pumice [Non renewable resources]	kg	0,00E+00
Neon [Non renewable elements]	kg	0,00E+00
Nepheline [Non renewable resources]	kg	0,00E+00
Nickel [Non renewable elements]	kg	6,53E-05
Nickel ore (1,5%) [Non renewable resources]	kg	9,79E-07
Nickel ore (1.2%) [Non renewable resources]	kg	7,84E-07
Nickel ore (1.6%) [Non renewable resources]	kg	1,04E-06
Nickel ore (2.0%) [Non renewable resources]	kg	1,31E-06
Nickel ore (2.7%) [Non renewable resources]	kg	1,76E-06
Niobium [Non renewable elements]	kg	1,93E-05
Olivine [Non renewable resources]	kg	2,37E-08
Palladium [Non renewable elements]	kg	5,71E-01
Palladium deposit (7ppm) [Non renewable resources]	kg	3,99E-06
Perlite [Non renewable resources]	kg	1,69E-09
Perlite (Rhyolithe) [Non renewable resources]	kg	1,69E-09

ADP e		
Problem oriented approach: baseline (CML, 2001), ADPelements (Oers et al. 2001)		
Flow	Unit	according to element content in Sb-Equivalent
Phosphate ore [Non renewable resources]	kg	1,80E-06
Phosphorus [Non renewable elements]	kg	5,52E-06
Phosphorus minerals [Non renewable resources]	kg	5,52E-06
Phosphorus ore (29% P2O5) [Non renewable resources]	kg	6,98E-07
Platin deposit (3ppm) [Non renewable resources]	kg	6,65E-06
Platinum [Non renewable elements]	kg	2,22E+00
Potashsalt, crude (hard salt, 10% K2O) [Non renewable resources]	kg	1,33E-09
Potassium [Non renewable elements]	kg	1,60E-08
Potassium chloride [Non renewable resources]	kg	1,28E-05
Precious metal ore (R.O.M) [Non renewable resources]	kg	5,21E-05
Pyrite [Non renewable resources]	kg	0,00E+00
Quartz sand (silica sand; silicon dioxide) [Non renewable resources]	kg	7,85E-12
Raw pumice [Non renewable resources]	kg	0,00E+00
Rhenium [Non renewable elements]	kg	6,03E-01
Rutile (titanium ore) [Non renewable resources]	kg	1,67E-08
Sand [Non renewable resources]	kg	0,00E+00
Sandy soil [Non renewable resources]	kg	0,00E+00
Selenium [Non renewable elements]	kg	1,94E-01
Selenium deposit (0.025) [Non renewable resources]	kg	4,85E-05
Shale [Non renewable resources]	kg	0,00E+00
Shale gas (in MJ) [Natural gas (resource)]	MJ	0,00E+00
Silicon [Non renewable elements]	kg	1,40E-11
Silt [Non renewable resources]	kg	0,00E+00
Silver [Non renewable elements]	kg	1,18E+00
Silver deposit (20ppm) [Non renewable resources]	kg	2,37E-05
Slate [Non renewable resources]	kg	0,00E+00
Sodium [Non renewable elements]	kg	5,50E-08
Sodium carbonate (soda) [Non renewable resources]	kg	2,39E-08
Sodium chloride (rock salt) [Non renewable resources]	kg	1,64E-05
Sodium nitrate [Non renewable resources]	kg	1,49E-08
Sodium sulphate [Non renewable resources]	kg	4,35E-05
Soil [Non renewable resources]	kg	0,00E+00
Specular stone [Non renewable resources]	kg	4,46E-09
Spodumen (LiAlSi2 O6) [Non renewable resources]	kg	4,32E-07
Stone and gravel from land [Non renewable resources]	kg	0,00E+00
Stone from mountains [Non renewable resources]	kg	0,00E+00
Stone, sand and gravel from sea [Non renewable resources]	kg	0,00E+00
Strontium [Non renewable elements]	kg	7,07E-07
Sulphur [Non renewable elements]	kg	1,93E-04
Sulphur (bonded) [Non renewable resources]	kg	1,93E-04
Sylvine [Non renewable resources]	kg	0,00E+00

ADP e		
Problem oriented approach: baseline (CML, 2001), ADPelements (Oers et al. 2001)		
Flow	Unit	according to element content in Sb-Equivalent
Talc [Non renewable resources]	kg	3,89E-10
Tantalum [Non renewable elements]	kg	4,06E-05
Tellurium [Non renewable elements]	kg	4,07E+01
Thallium [Non renewable elements]	kg	2,43E-05
Thorium [Non renewable elements]	kg	0,00E+00
Thulium [Non renewable elements]	kg	0,00E+00
Tin [Non renewable elements]	kg	1,62E-02
Tin ore [Non renewable resources]	kg	1,62E-06
Tin ore (0,01%) [Non renewable resources]	kg	1,62E-06
TiO ₂ , 54% in ilmenite [Non renewable resources]	kg	1,67E-08
TiO ₂ , 54% in ilmenite, 2.6% [Non renewable resources]	kg	1,67E-08
TiO ₂ , 95% in rutile, 0.40% [Non renewable resources]	kg	1,67E-08
Titanium [Non renewable elements]	kg	2,79E-08
Titanium dioxide [Non renewable resources]	kg	1,67E-08
Titanium ore [Non renewable resources]	kg	1,67E-08
Tungsten [Non renewable elements]	kg	4,52E-03
Tungsten ore (1%) [Non renewable resources]	kg	4,52E-05
Ulexite [Non renewable resources]	kg	0,00E+00
Uranium ecoinvent [Uranium (resource)]	kg	1,40E-03
Uranium free ore [Uranium (resource)]	kg	1,13E-03
Uranium natural (in MJ) [Uranium (resource)]	MJ	2,50E-09
Uranium oxide (U ₃ O ₈), 332 GJ per kg, in ore [Uranium (resource)]	kg	1,19E-03
Uranium, fuel grade, 2291 GJ per kg [Uranium products]	kg	1,40E-03
Uranium, in ground [Uranium (resource)]	kg	1,40E-03
Vanadium [Non renewable elements]	kg	7,70E-07
Vanadium ore (V ₂ O ₅ 0.94%) [Non renewable resources]	kg	4,06E-07
Vermiculite [Non renewable resources]	kg	0,00E+00
Wollastonite [Non renewable resources]	kg	3,37E-12
Xenon [Non renewable elements]	kg	0,00E+00
Yttrium [Non renewable elements]	kg	5,69E-07

ADP e		
Problem oriented approach: baseline (CML, 2001), ADPelements (Oers et al. 2001)		
Flow	Unit	according to element content in Sb-Equivalent
Zinc [Non renewable elements]	kg	5,38E-04
Zinc - Copper - Lead - Ore (2.11% Zn 0.51% Cu 0.86% Pb)	kg	7,28E-05
Zinc - Copper - Lead - Ore (4% Zn 0.09% Cu 0.65% Pb) [No]	kg	7,50E-05
Zinc - Copper - Lead - Ore (5.37% Zn 0.22% Cu 0.2% Pb) [N]	kg	4,46E-05
Zinc - Copper - Lead - Ore (6.95% Zn 0.13% Cu 2.04% Pb)	kg	1,68E-04
Zinc - copper ore (4.07%-2.59%) [Non renewable resources]	kg	5,73E-05
Zinc - lead - copper ore (12%-3%-2%) [Non renewable resour]	kg	2,82E-04
Zinc - Lead - Silver - Ore (7,5% Zn; 4,0% Pb; 40,8 g/t Ag) [N]	kg	3,42E-04
Zinc - Lead - Silver - ore (8,54% Zn; 5,48% Pb; 94 g/t Ag) [N]	kg	5,05E-04
Zinc - Lead Ore (21.7%-5.6%) [Non renewable resources]	kg	4,72E-04
Zinc - lead ore (4.21%-4.96%) [Non renewable resources]	kg	3,37E-04
Zinc - lead ore (R.O.M) [Non renewable resources]	kg	3,37E-04
Zinc Ore (12.6% Zn) [Non renewable resources]	kg	6,78E-05
Zinc ore (3,98%) [Non renewable resources]	kg	2,14E-05
Zinc ore (4%) [Non renewable resources]	kg	2,15E-05
Zinc ore (8%) [Non renewable resources]	kg	4,30E-05
Zinc Ore (9.7-14% Zn 3.1-6.5% Pb) [Non renewable resource]	kg	3,68E-04
Zinc ore (sulphide, zinc 3,98%) [Non renewable resources]	kg	2,14E-05
Zinc ore (sulphidic, 4%) [Non renewable resources]	kg	2,15E-05
Zinc, Zn 0.63%, Au 9.7E-4%, Ag 9.7E-4%, Cu 0.38%, Pb 0.1	kg	5,38E-04
Zirconium [Non renewable elements]	kg	5,44E-06

Remark: Any value given for the mineral resources as “0” is on purpose, as these resources are not considered scarce in human time frames.

4.6.6 Renewables

Please refer to the separate document Agricultural LCA model background documentation 2020, which is also available on the Sphera home page at <http://www.gabi-software.com/index.php?id=8375>.

4.6.7 Electronics

The distinct characteristics of electronic and electro-mechanic components are complexity, sizeable numbers and the variety of part components. Considering the existing part components, more than 10 million components can be counted. An electronic subsystem (e.g., PWB – Printing Wiring Board) is often equipped with several hundreds of different components.

The demand exists to make datasets for electronic components available, since electronics are applied in various fields such as automotive, houses, consumer products, and information and communication systems. It is currently not possible from a timeframe and resource perspective to create an individual dataset for each of the 10 million electronic components. The challenge here is selection, which datasets to utilise, how to deal with the vast amount of parts and how to reduce the numbers of datasets by providing the representativeness of those datasets.

In order to make a statement about the representativeness of an electronic component, the whole scene must be understood. The extensive experience of the electronics team at Sphera facilitates representative component determination, after having analyzed hundreds of electronic boards and always/often/rarely-used components and their applications. Knowledge of often-used materials and most significant steps of component manufacture are also important. The identification of significant manufacturing steps is supported by other technical fields. If data are not directly acquired from the electronics supply chain, either similar technical processes or comparable technical fields in which the identified manufacturing processes have been applied, supporting the determination of the relevant environmental impact. Only the interaction of all three conditions: experience, knowledge about similar processes and knowledge concerning the market situation, make the identification of relevant and representative components with their technologies and materials possible.

Even though not all electronic components can be judged according to their representativeness, the most relevant causes of environmental potentials from groups of similar electronic components can be identified, after the investigation of a certain amount of products. For example, the difference in environmental impacts is possible to identify between semiconductors and resistors, or between active components (e.g., semiconductors, diodes and discrete transistors) and passive components (e.g., capacitors, resistors, inductions), or even by comparing different types of technologies (e.g., SMD (surface mount device) or THT (through hole technology)). The more knowledge is gained, the better and easier it is to identify which fields and components of electronic products cause significant and less significant environmental impacts.

In order to model representative electronic products, subsystems or components, environmental knowledge and availability of huge numbers of materials are necessary, such as metals, plastics and ceramics, since electronic products can consist of most elements in the periodic table. Additionally, a broad range of many technical manufacturing processes and their environmental causes are necessary to know, such as sputtering, lacquering, sintering, winding, soldering, clean room condition, etching, electrolysing, vacuum metal dispersion and many more.

As a result, a list of electronic components covers this vast milieu. Its representatively is distinguished by various specifications related to their function, size, housing types, material content and composition, as well as mounting technology.

Clearly structured nomenclature including all required information for component specification ensures the intended use of available datasets:

Examples for dataset nomenclature:

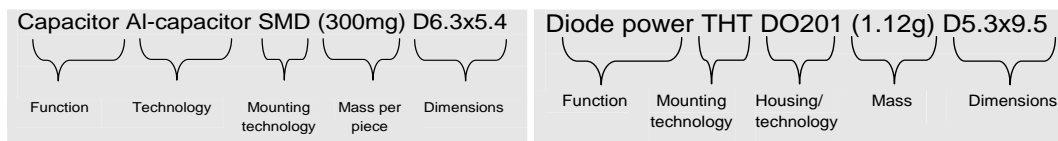

For representative LCI models of electronic assemblies and systems, like populated printed wiring boards, the following Modelling Principles are applied:

- Electronic components are modelled according to component-specific properties, e.g., function, case type, size, number of pins, die size, SMD/THT.
- Electronic components are modelled according to a functional unit “Number of pieces.”
- In the event that a dataset representing a component to be modelled is not available in the GaBi database, , informed assumptions are made by choosing electronic components that are most similar, and related to housing types, function and production processes. A component-scaling tool is available to support such a selection process.

Printed wiring boards (PWB) are mainly modelled by area (functional unit) due to fact that PWB dimensions and number of layers are the most sensitive parameters for PWB-related environmental impacts and primary energy use.

Modelling

Based on the necessity to model and assess electronic systems with justifiable effort, the electronics team of Sphera developed the modular system called Generic Modules system. The target is to establish a Generic Module for each group of electronic components, e.g., resistors, ceramic capacitors or substrates.

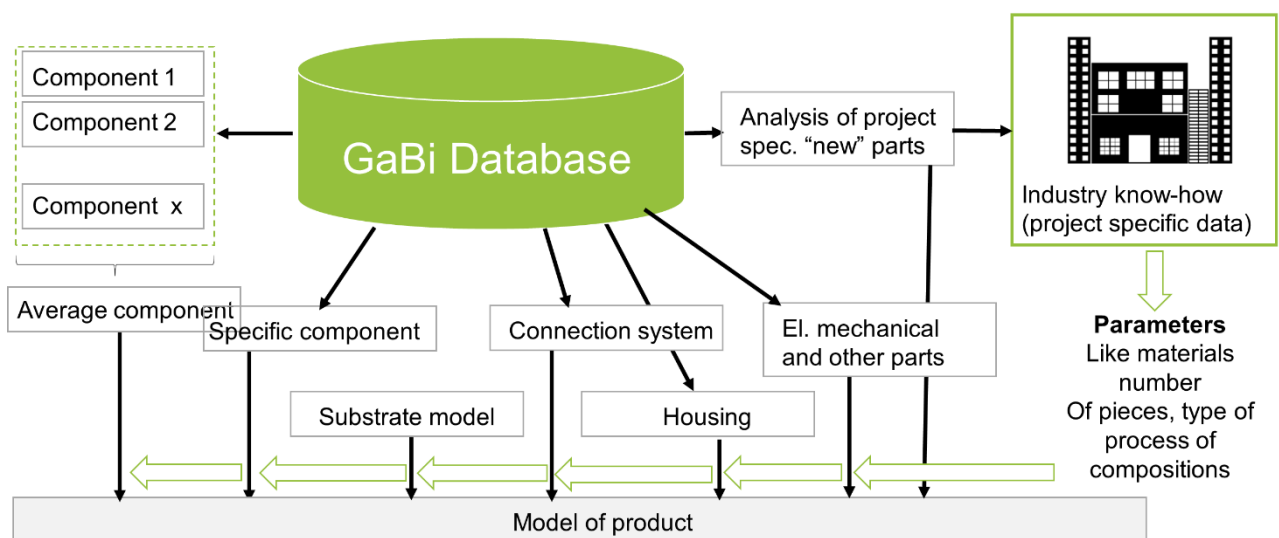

Figure 4-12: Creation of a model for an electronic product – modular structure via Generic Modules

The model based on Generic Modules of a typical electronic system follows a hierarchical structure. The system is divided into several subsystems. The subsystems themselves are modelled based on the Generic Modules, as presented in Figure 4-12.

Technical systems form the basis for highly flexible modules. With few variable parameters such as size, number of layers and type of finishing in the case of a PWB, these modules can be adapted to a specific product or system under consideration.

After the determination of the representative components and their relevant technologies, for typical electronic subsystems, a Generic Module is created: housing, substrate, connection system, electronic components and electro-mechanical parts:

Housing: Typical housings are made by injection moulding of plastics (e.g., PC/ABS) or are metal housings (e.g., from aluminium die casts or steel sheets). The models contain all relevant preliminary process steps. For plastic housings it is crude oil extraction, production of plastic granulate and the injection moulding itself, including the respective demand for auxiliaries, energies and transport in each process step.

Substrate: The substrate is the PWB without components or the connection system. PWBs are modelled according to the number of layers, size, weight and composition (e.g., content of copper, glass fibres, TBBA or Au/Ni finishing). If this information is not available, pre-defined average compositions may be used as described above.

Connection system: Usually solder pastes, formerly mainly SnPbAg and now typically lead-free solders, are used based on a number of varying metal solder elements.

Electronic components: An extensive database containing the material contents of the main groups of components such as resistors, capacitors, coils, filters, transistors, diodes and semiconductors are available. Seeing as millions of different components may be contained in electronic products, they are reduced to several representative components and are constantly updated and extended.

Electro-mechanical and other parts: This subsystem contains models of switches, plugs, heat sinks or shielding and other non-standard parts such as displays, keys or sensors.

The Generic Modules are adapted via variable parameters. The significant functional units used depend on the subsystem, e.g., piece for components, area for boards and assembly lines, kilograms for solders and electro-mechanics.

The GaBi database contains aggregated datasets for components, which are based on the above-described Generic Modules. Further datasets can be set up easily using the Generic Modules.

4.6.8 Recycling and other End-of-Life treatments

Resource conservation and keeping valuable materials in the technical life cycles are relevant aspects in analyzing the environmental performance of many materials.

After the life cycle phases of production and use/maintenance several options exist concerning the further application of used materials and products (like recycling, recovery and disposal or any share of each) or offsetting their secondary value.

According to ISO, only elementary flows (plus the product flows) describe a Life Cycle Inventory. Secondary materials such as scrap (like metal scrap or glass cullet) represent non-elementary flows and are linked to previous or subsequent product life cycles. Within a LCA study, these flows are typically modelled following methodological approaches such as cut-off approach, closed loop approach, open loop approach and value-corrected substitution approach.

Within the GaBi Databases [GABI] the cradle-to-gate data for metals (or container/float glass) still list the externally supplied secondary material inputs (e.g., carbon steel scrap sourced from merchants or other steelworks), if given and of significance regarding the overall environmental performance. This allows the user of the dataset to apply the methodological approach of choice to analyse in detail the potential/benefit of recycling along the life cycle of a product. Example life cycle models are provided within the GaBi Databases for user guidance [GABI].

In cases where an input or output of a secondary material is of no or very low relevance regarding the environmental life cycle performance of a material or product, the modelling of secondary material inputs or outputs is completed, using the “value of scrap” approach, to avoid misinterpretation²¹.

The “value of scrap” approach addresses the question of how to deal with the recycling of metal scrap in LCA/LCI. The principle idea behind the approach is to define the Life Cycle Inventory of metal scrap, describing the “value of scrap.”

The “value of scrap” is defined as the difference in LCI of the (theoretical) 100% primary and 100% scrap production routes in metal production, considering the process yield of the recycling step.

Datasets provided with GaBi with the “value of scrap” are carbon steel scrap by World Steel Association (worldsteel) and stainless steel scrap by the European Steel Association (EUROFER).

Furthermore, we provide datasets on “value corrected substitution”. The intent is to apply a value-corrected credit for the substitution of metals in open-loop recycling situations where the inherent properties of the material have been changed in the sense of down cycling. To apply

²¹ The possible (small) error made introduces much less uncertainty than the potential (large) error to be made, if left untreated.

the dataset, connect the EoL scrap flow (after collection and separation, but before remelting) to the input of this process flow of the type [Waste for recovery]. Then connect the primary metal dataset to be substituted, to the negative input flow of the type [Metals]. The negative input applies the appropriate credit for the scrap class stated in the process name (e.g., aluminium auto fragments, baled used beverage can, etc.). The parameter for the price ratio represents the ratio between the scrap class and the LME primary metal price, which may be changed by the user, if necessary, using the referenced sources.

Recycling

Two general different recycling cases can be found in LCA discussion: Closed loop recycling and open loop recycling.

Closed loop recycling involves the recycling, recovery or reuse of material in a quasi-identical second use, including the respective demand to do so.

Open loop recycling corresponds to the conversion of material from one or more products into a new product or other application, involving a change in the inherent properties of the material itself (often with quality degradation).

Recycling can be understood as allocation between different life cycles. Time must be taken into account for durable products and the current situation of production must be separated from that of future recycling options and possibilities. For production, the current market situation must be assessed (ratio of primary material to recycled material in current production). In parallel, the recycling potential reflects the gross “value” of the product that principally exists in EOL. The net recycling potential reflects the current secondary material use in the market situation (deducted from the theoretical “value”).

In the GaBi Databases, current secondary material use and recycling rates are modelled according to the individual commodity or material and the respective market situation. Please see the specific data and chapters below for details. GaBi focuses on consistency of recycling and end-of-life processes like incineration, landfill and wastewater treatment with all other life-cycle stages. Three generic models were therefore generated:

- 1) Waste incineration model
- 2) Landfill model
- 3) Wastewater treatment model

These models follow the general rules of the Modelling Principles. All models represent standard technologies and are based on parameterised unit processes. For the generation of datasets (e.g., DE: Landfill for inert matter), the models are specified according to the conditions as outlined in the dataset documentation. Included are country or region-specific background

datasets, country or region-specific process efficiencies and specific input information about the characteristics of waste and wastewater.

Incineration model

The incineration model is defined based on the treatment of average municipal solid waste (MSW). The thermal treatment of a single waste fraction like paper or plastic or even specific wastes like Polyamide 6 is not actually done in a waste-to-energy (WtE) plant. The model and settings for the average MSW allow the environmental burden (emissions and resource consumption of auxiliaries), energy production, as well as the credits (metal scrap recovery) to be attributed to a single fraction or specific incinerated waste within a standard MSW. The following figure gives an overview of the first level of the GaBi incineration model.

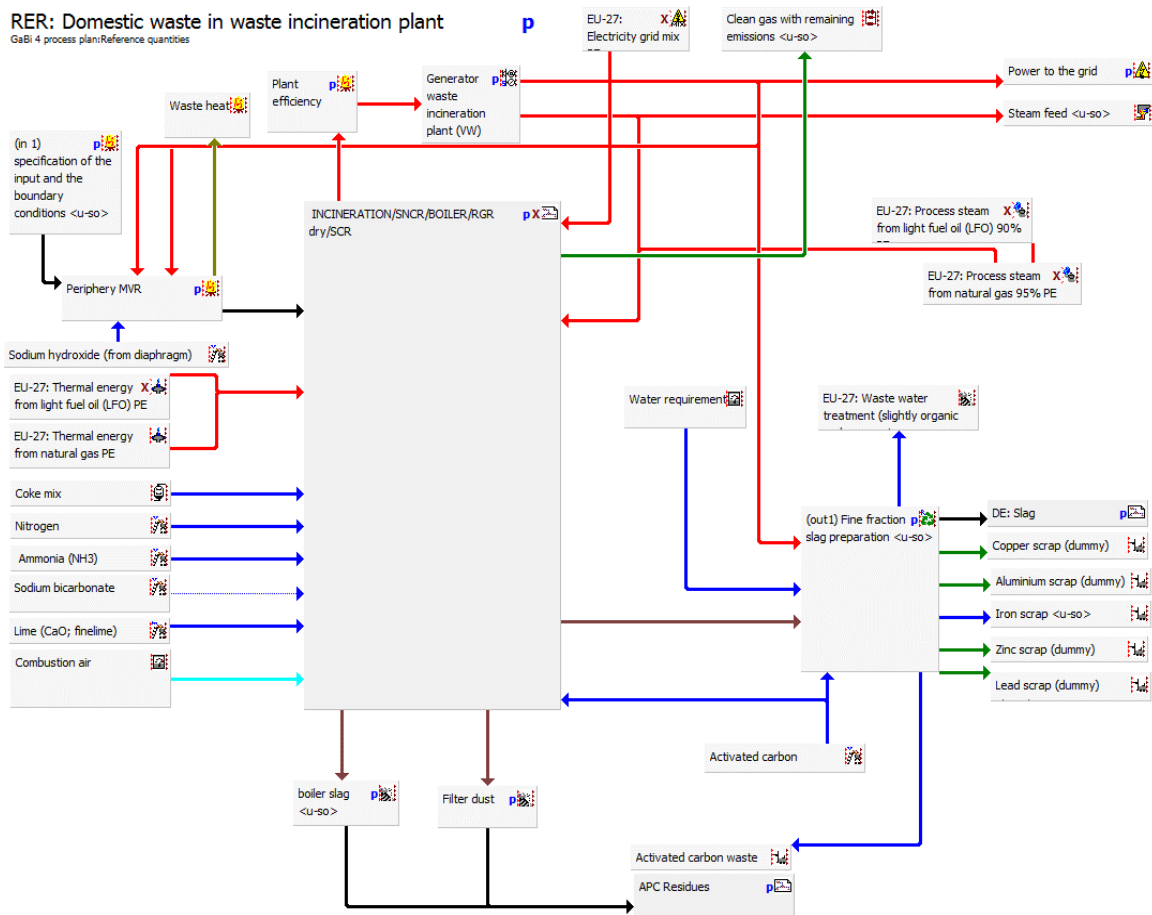

Figure 4-13: Exemplary incineration model with in GaBi (here average European domestic waste treatment with dry off-gas cleaning)

The output of energy products (electricity and steam) leaving the product system is dependent on the heating value of the specific input and the internal consumption of energy necessary to treat the specific waste. The internal energy consumption is calculated based on the elementary composition of the specific input (e.g., energy demand for flue gas treatment) and standard values (e.g., handling of waste before incineration). The gross energy efficiency and the share of

produced electricity and steam is taken from the country-/region-specific average WtE plant for municipal solid waste (MSW) in Germany or Europe.

Opening up the core plan “incineration/SNCR/Boiler/Off-gas treatment” of the previous figure will show further detail of the GaBi incineration model.

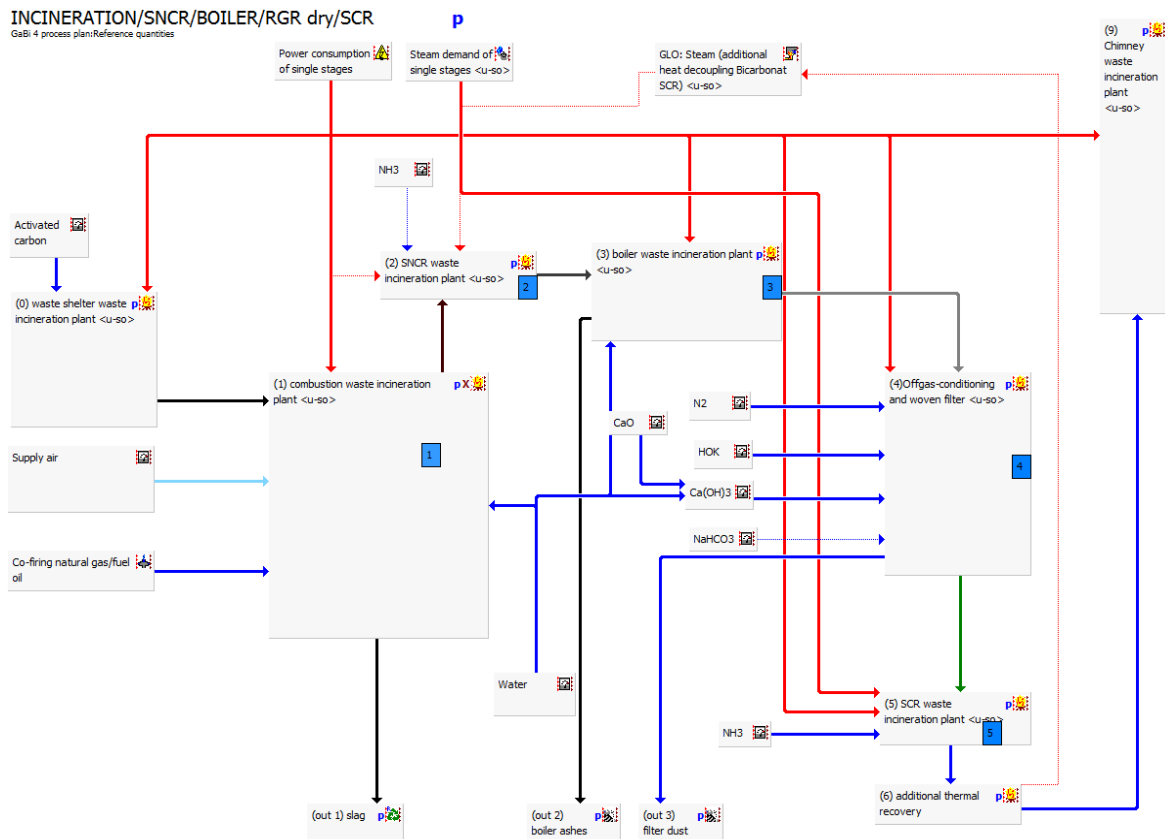

Figure 4-14:Details of incineration and dry off-gas cleaning in GaBi incineration model

The incineration model was set-up to account for two technologies (wet and dry off-gas treatment) and verified with measured data from a number of German and European incinerators, as well as data from literature. The heating value of the input can be specified or calculated based on the elementary composition of the input. The material flow in the plant is calculated using individual transfer coefficients for every element and stage of the incinerator. The transfer coefficients for the final release of the flue gas to the atmosphere is verified and adapted with literature data and real plant data of European and WtE plants.

For input specification in the model, the following elements and compounds can be used: Ag, Al, AlO_x, As, ash, Ba, Br, C_Carbonate (inorganic carbon), C_HC (fossil carbon), C_HB_Bio (biogenic carbon), Ca, Cd, Cl, CN, Co, Cr, Cu, F, Fe, H, H₂O, Hg, J, K, Mg, Mn, N, Na, NH₄, Ni, O, P, Pb, S, Sb, SiO₂, Sn, SO₄, Ti, Tl, V, Zn.

The modelled emissions to air in the flue gas of the incinerator are: As, Ba, Cd, Co, CO, CO₂ (fossil and biogenic), Cr, Cu, dioxins, HBr, HCl, HF, HJ, Hg, Mn, N₂O, NH₃, Ni, NMVOC, NO_x, particles, Pb,

Sb, Sn, SO₂, Tl, V, Zn. Most of the emissions leaving the system are input-dependent. That means there is a stoichiometric correlation between input and output. Other emissions are a function of the technology utilised and therefore independent of the specific input. The input-dependent emissions are linear to the elementary composition of the waste. The technology dependent emissions are constant in a specific range. Input-dependent parameters are the emissions CO₂, HCl, HF, SO₂ caused by the relevant input of these elements. The amounts of slag, boiler and filter ash produced, as well as recovered ferrous metal scrap, are also input-dependent. Technology dependent parameters are CO, VOC and dioxin emissions.

Ashes and filter residues that are dumped in specific hazardous waste underground dumps – as in the 2011 version – but are accounted for as “hazardous waste (deposited)” are to acknowledge EPD best practise.

The datasets already include the credits given for the recovery of ferrous metal scrap.

Landfill model

The elementary and system flows to and from the landfill site are allocated to the elementary content in the waste input. The amount of generated landfill gas is calculated based on the organic carbon content in the waste input and represents an average landfill gas composition.

Landfill (Commercial waste for municipal disposal; FR, GB, FI, NO) [p-agg] 
Process plant Reference quantities

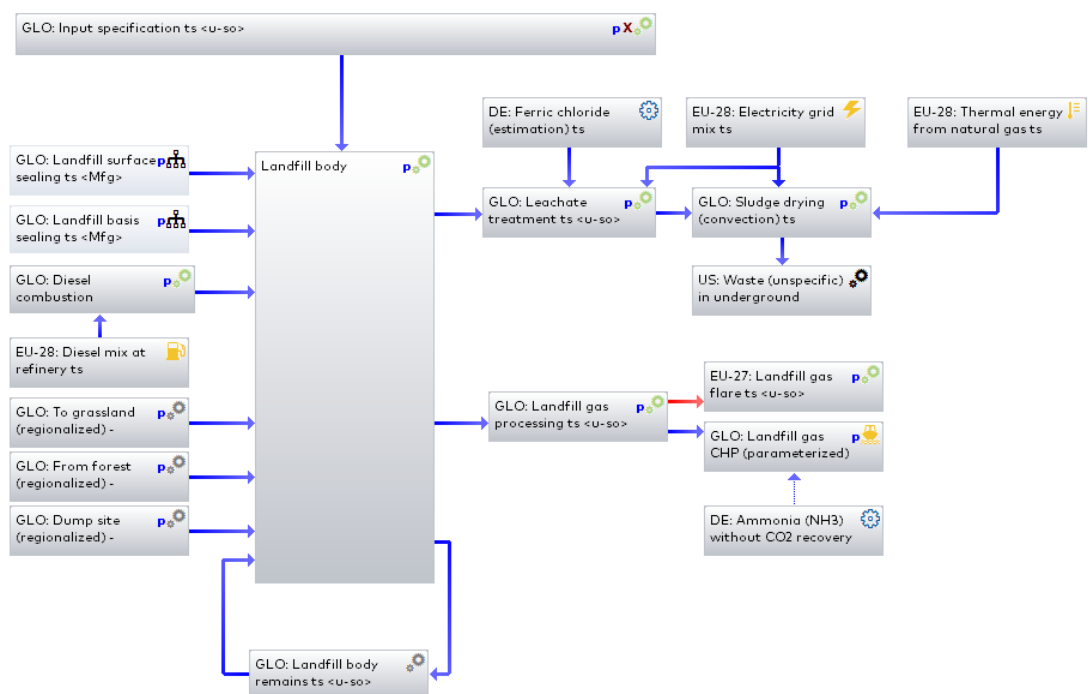

Figure 4-15: Exemplary landfill model in GaBi (here commercial waste composition for certain geographic example regions)

The input of auxiliaries for the landfilling of one kilogram of waste is partially constant for all types of wastes (e.g., energy for compacting, materials for the landfill construction) and partially dependent on the elementary composition of the waste (e.g., ferric chloride for the treatment of leachate). The inert landfill sites do not generate landfill gas, nor is the leakage technically treated before going to the receiving water.

Landfill gas losses/flare and recovery ratios were checked and adapted to reflect the latest information.

The landfill model is parameterised to allow the generation of different datasets according to the waste input and region/country specific details. Important parameters and parameter sets:

- elementary composition of the disposed waste
- different technologies for the sealing and cap (layers)
- differing surrounding conditions (e.g., precipitation)
- rates and treatment routes of collected landfill gas and CHP efficiencies and rates (combined heat and power production)
- rates of leakage collection and treatment efficiencies (COD and AOX)
- transfer coefficients to describe the fate of elements over a period of 100 years

The waste input can be specified by its elementary composition (27 elements) and additional waste-specific information (e.g., inert substances content, non-degradable carbon and nitrogen content).

The model of the landfill body calculates, based on the element specific transfer coefficients, the input dependent amount of substances and elements going to leakage collection, landfill gas and soil.

The amount and types of materials for the cap and sealing of the landfill site are adapted to specific situations (background processes, thickness of layers rates of leakage collection), where relevant and applicable.

The collected leakage is either going to a technical treatment (to minimise the organic compounds in the wastewater) or directly to the receiving water (landfill site for inert waste). In case of technical treatment of the leakage, the generated sludge is dried and disposed of in an underground deposit.

Part of the landfill gas is collected and either flared or used to produce electricity or both electricity and heat. The uncollected landfill gas is directly released to the atmosphere. The share of the different treatment route of landfill gas can be adjusted to the country or region-specific

situation. For simplification reasons, the landfill gas composition only represents the average useable landfill gas. The amount depends on the organic carbon content in the waste composition and the assumed degradation over 100 years.

Wastewater treatment model

The elementary and system flows to and from the wastewater treatment plant are allocated to the elementary content in the wastewater input.

The wastewater treatment represents an average/typical wastewater treatment from industrial processes. It contains mechanical, biological and chemical treatment steps for the wastewater (including precipitation and neutralisation), and treatment steps for the sludge (thickening, dewatering). The outflow goes directly to the receiving water (natural surface water).

Municipal waste water treatment with biotic CO₂-emission (Output: dried sludge) P
Process plant reference quantities

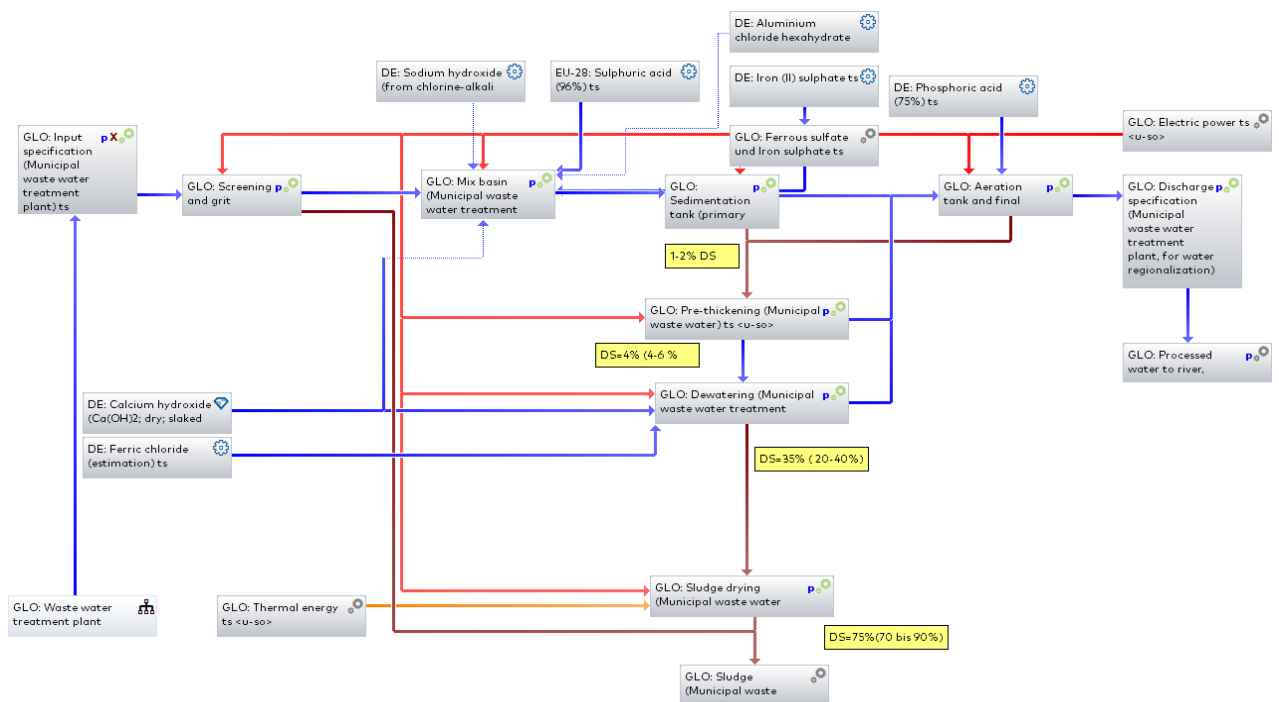

Figure 4-16: Exemplary wastewater treatment model in GaBi (here municipal wastewater for German setting)

The process steps take average elimination and transfer coefficients into account. The sewage passes through the bar screens for rag removal. In this section, automatic bar screen cleaners remove large solids (rags, plastics) from the raw sewage. Next, the sewage is transported to the grit tanks. These tanks reduce the velocity of the sewage so heavy particles can settle to the bottom. In the separator, suspended particles such as oils and fats are removed. The settlement tank can remove the larger suspended solids. FeSO_4 , and $\text{Ca}(\text{OH})_2$ are used as precipitant agents in the mixing tank to remove metals. $\text{Ca}(\text{OH})_2$ and H_2SO_4 regulate the pH value. The primary

clarifiers remove the suspended solids from the mixing tank prior to discharge to the aeration tanks. The aeration tanks provide a location where biological treatment of the sewage takes place. The activated sludge converts organic substances into oxidised products, which are settled out in the secondary clarifiers. Phosphoric acid is used as nutrient for micro-organisms. The cleared overflow in the secondary clarifiers goes to a natural surface water body (stream, river or bay). The settled solids, from the settlement tank, the primary clarifiers and secondary clarifiers, are pumped to the primary thickener where the solids are thickened (water content of the thickened sludge is 96%). The sludge is pumped to filter presses for dewatering, which use chemical flocculants to separate the water from the solids (water content of the dewatered sludge is 65%). In this dataset, sludge for agricultural application is produced. For this reason, the sludge is not dried and supplied after dewatering. The output is wet sludge (dry content is 35%) containing N, P₂O₅ and K₂O according to statistics and calculations which is included in the plan for the given fertilizer credit.

5 Review, documentation and validation

Data that is officially published in publications or a web page is not sufficient proof of its quality. Even if professional review processes are in place for journal publications, the scientific quality of the article or paper can be proven, and the “correctness” of the underlying data cannot be validated in most cases. Even if it is easier for the user to simply “cite” a data source, a validation or verification routine for the data is essential.

There is presently no specific ISO standard in existence for data quality reviews. The existing ISO standards ensure quality and consistency of LCA reporting.

5.1 Review procedures and check routines

The core principle of Sphera is to provide quality information. Sphera has therefore set up a review and validation procedure within its GaBi Database concept and management scheme based on the four quality check layers:

- Internal entry quality checks
- Internal resulting quality checks
- External resulting non-public quality checks
- External resulting public quality checks
- Additional External review activities:

Different parts of the GaBi Databases were reviewed by different external organisations, since 2012: The ILCD compatibility of selected GaBi processes across all branches was reviewed for the European Commission’s JRC by the Italian National Agency for new Technologies, Energy and Sustainable Economic Development (ENEA), Italy. In the light of the upcoming Environmental Footprint (EF) Initiative of the EU Commission, the Spanish “Centro de Investigaciones Energéticas, Medioambientales y Tecnológicas (CIEMAT)” reviewed our data with focus on energy systems. Both the two above reviews have been commissioned by the European Commission. Moreover, Sphera has delivered more than half of the official Environmental Footprint (EF) 2.0 databases to the European Commission from 2016 to 2017 and is currently working on version EF 3.0. The datasets are derived from GaBi Databases with some methodological adjustment in order to make the data EF conformant. All the EF datasets underwent an external, independent review, thereby assuring the quality of the underlying GaBi models. This covers the sectors energy, transport, packaging (non-plastic), plastics, End-of-Life (including recycling, energy-recovery, landfilling), minerals and metals, electrical and electronics.

To complement our responsibility concerning external reviews Sphera introduced a critical review process of its GaBi database with inspection and verification company DEKRA. As LCA continues to be used more broadly in industry, companies require increased accuracy, transparency and credibility of their data sources in order to make the best-informed decisions. Recognising this

and in order to ensure consistency and quality of its GaBi database, Sphera finalized the first round of an “ongoing critical review process with DEKRA”.

See Chapter 2.1 for more details. It is important to base the review of data and databases on ISO principles accompanied by practical experiences in data collection, data set-up, database maintenance and updates in industrial practises. Plausibility and technical routines in GaBi raw data²² and process data handling are the main instruments to avoid, detect and reduce errors.

These routines support data collection and systematic error identification in inventories by understanding the underlying technical process and being able to identify potentially incorrect or missing values and flows (conspicuous values, type faults, conversion/unit errors).

5.1.1 Technical information and documentation routines in GaBi

The checklist for the collected data and resulting unit process information, which is documented either on plan system level, in the unit process or in the resulting aggregated process:

- Data source (reproducibility), reliability of the sources, representativeness of the sources
- Technical conditions (state of the art, conventional process, established process, pilot plant, laboratory operation)
- Process integration: Stand-alone process or integrated into a large facility
- Calculation method (average, specific)
- Technically relevant process steps are represented on plan system level
- Types and quantity reactant/product
- Efficiency/stoichiometry of chemical reactions; monitoring of the rate of yield
- Types and quantity of by-products, wastes or remaining and its fate
- Emissions spectrum (relation between in- and outputs, comparison to similar processes)
- Types and quantity of circulating flows (purge, monomers, production recycling material)
- Auxiliary material and utilities
- Input chemicals and substances for end of pipe measures (lime, NH₃)

These technical information points help to identify gaps and enable balance checks and plausibility checks.

5.1.2 Important material and energy balances

The following balance checks are done with any unit process and plan system, to trace and eliminate gaps and errors.

- Energy balance: net or gross calorific value (sum of renewable and non-renewable)
- Mass balance (what goes in must come out)
- Element balance: often C or metal content (also check for raw material recovery)

²² Raw data is any data or metadata needed so set up an LCI dataset

- Reaction equations

5.1.3 Plausibility of emission profiles and avoiding errors

The basic principle is to avoid too high and too low values and/or missing emissions. The plausibility and error checking must therefore not only take place on the process level but also on the plan and supply chain level.

There are typical emissions for typical industrial operations for each type of process. These indications are used to monitor and compare similar processes. Knowing the frequent error sources is the best way to manage and avoid them.

Data entry with the wrong comma/point setting (factor 10, 100, 1000) results in figures that are too high or too low. New or updated data in GaBi is double-checked, individually by the data developer with existing or comparable datasets, and in the case of bigger data volumes, automatically (“GaBi process comparison tool”) by routine checks of the relevant impacts with the predecessor.

Another error source is data entry with wrong units:

- mg – µg or kg – t leads towards factor 1000 / 0.001 error
- MJ – kWh leads towards factor 3.6 / 0.28 error
- BTU – kWh leads towards factor 1000 / 0.001 error
- BTU – MJ leads towards factor 3000 / 0.0003 error

GaBi supports the avoidance of this error by offering automatic unit conversion.

If the emissions or impacts appear to be surprisingly **low**, the following checks are undertaken in GaBi database work:

- connection of significant processes back to the resource (aggregated dataset or plan system of upstream processes)
- modelling of fuels only, omitting combustion emissions in the unit process (thermal energy or emission modelling)
- transports are modelled but not adjusted to the correct distances
- unsuitable substitution used
- wastewater impacts not modelled (wastewater leaves untreated)
- burden free entry of secondary materials into the life cycle phase
- CO₂ balance not addressed (renewable), CO₂ intake or emission not/wrongly considered

If the emissions or impacts appear to be surprisingly **high**, the following checks are undertaken in GaBi database work:

- by-products not substituted or allocated
- system expansion not suitable (loss of focus or function added in unsuitable way)
- useful energy output (e.g., steam) not considered correctly

- waste treatment or wastewater treatment overestimated, scrap input modelled as pure primary route (sector-specific)
- CO₂ balance not addressed (renewable), CO₂ intake or emission not/wrongly considered

Plausibility and error checks are critically discussed and optimised in data-related projects with industrial customers and respective critical reviewers of our work, with our academic cooperation partners, IABP- University of Stuttgart and Fraunhofer IBP, as well as with independent testing and certification partners.

5.2 Documentation

Documentation is essential in order to assure reproducibility and transparency of the datasets, as well as to clarify the scope of the datasets and the possible applications.

In GaBi documentation, recommendations to mandatory and optional information, which are either based on international standards such as ISO 14040, ISO 14044 and other schemes, particularly ILCD and EF or on the experience of Sphera and IABP- University of Stuttgart. The requirements of ISO 14040 [ISO 14040: 2009] and 14044 [ISO 14044: 2006] are considered.

The metadata documentation of the datasets in “GABI database [GABI]” is based on the documentation recommendations of the “International Reference Life Cycle Data System” [ILCD 2010] Handbook of the European Commission’s JRC, document “Documentation of LCA data sets” that is still in place and use for EF 2.0 and EF 3.0 as well.

Please see the individual GaBi documentation [GABI] in the respective LCI processes of the GaBi database (example of documentation is shown in Chapter 5.2.3) or on the GaBi Webpage <http://www.gabi-software.com>.

5.2.1 Nomenclature

Consistent nomenclature is an essential aspect of the database quality. Any database object including impact characterization factors or flow characteristics like calorific values, flows, processes and plan systems must be properly named.

Flow and process names are especially important. Process and flow naming applies the EF/ILCD Nomenclature, after export to ILCD format also all elementary flows are mapped to the official ones of EF 2.0 and EF 3.0. The flows and processes in GaBi are moreover arranged in a hierarchy for storage.

The flow hierarchy is structured according to technical aspects (for non-elementary flows and resources) and according to emission compartments air, water and soil.

In general, all relevant LCI elementary flows (resources and emissions) in GaBi are pre-defined. Therefore, the number of elementary flows that must be newly defined by the user is few to none.

If a new process or new flow is created because it is not available in the database, consistency with existing processes or flows is kept.

In the GaBi database, flows and processes are bi-unique, which is an important basis of consistency and a prerequisite for data exchange.

5.2.2 Documentation of Flows

The documentation of flows is an important component of the inherent documentation of processes and LCI results. Flow documentation is an integral part due to the direct influence of the flow properties to the results of LCI and LCIA.

Flows in GaBi are (if suitable) documented by:

- Reference quantity
- Synonyms of the main flow name
- CAS number
- Sum formula
- Region or location of the flow, e.g., region Western Europe
- Field for general comments to add further information

Information for the flow such as synonyms and CAS number are documented in GaBi according to ILCD (see Figure 4-12).

Limited use flows

Within the GaBi database, Sphera takes special care that the flows used in the datasets:

- are consistently used,
- comply to relevant schemes, such as the ILCD/EF flow list (or are matched to the ILCD/EF flow list when exporting data in the ILCD format),
- avoid double counting,
- are consistently regionalised,
- lead to meaningful results for the LCIA methods listed in the documentation of the process,
- are modelled to their end-of-waste status so that aggregated datasets do not contain waste flows (please see also chapter 3.3.9 and 3.3.10 on waste modelling) and
- have a suitable reference unit that matches the unit in which it is usually measured.

Especially the datasets with the source “ts” or “ts/xxx” can be used without any extra attention needed.

It is however not possible for Sphera to fully control 3rd party datasets or to fully anticipate the special decision context in which a flow is used in an LCA project. With the service pack 40 Sphera has therefore introduced a new flag to raise the awareness of GaBi database  users to a handful of flows that need special attention and require a look in the flow documentation for more information on the flow.

This is a reaction to the growing interest of GaBi database users to comply with their LCA models to standards like the ILCD/EF flow list or growing questions about the usability of flows and 3rd party datasets within the decision context of the project.

The basic idea is:

- If you want to use a flow, watch out for the new flag.
- Then have a look in the documentation of the flow, which kind of problem might arise if you use it.
- Then decide if this is a problem at all, within your decision context, and whether you want to use this flow or not.

It is not the case that the marked flows are not to be used at all, but that their usability needs to be checked. The flow documentation gives you information about the possible problem and also about possible actions to avoid the problem.

An easy example:

In your LCA project you want to focus on the assessment of the health problems associated with very small particles in the air, as these came out to be most relevant for your case. Obviously, the emission flows used in your project need to carry information of the particle size. The flow “dust (unspecified)” lacks this information and using it will therefore not lead to meaningful results. If in your project however other environmental problem fields dominate that do not depend on the particle size, such as Global Warming, Acidification or Eutrophication, you may use “dust (unspecified)” without harm. Please note that you should document that choice of scope, so that your colleagues or other users of your data are aware of this restriction.

5.2.3 Documentation of LCI process data

The documentation of the LCI datasets in GaBi covers relevant technical and supply chain information that is necessary to understand the technological basis and background of the modelled system. Further, multiple metadata are given to enable the further use within important documentation schemes like ILCD, EPDs and EcoSpold. For further details, see the documentation tab in each dataset that provides you full ILCD/EF documentation of GaBi datasets and allows you to also accordingly document your own datasets and hand over fully documented datasets when you export them e.g., as ILCD formatted datasets.

Name: DE Electricity grid mix | LCI result

Parameter: LCA, VF, LCC: 2,8 EUR, LCWE, Documentation

Process information

Key information

Treatment, standards, routes: AC, technology mix

Mix and location types: consumption mix, at consumer

Further quantitative specifications: < 1kV

Synonyms: Power grid mix

General comment: The data set represents the average country or region specific electricity supply for final consumers, including electricity own consumption, transmission/distribution losses and electricity imports from neighboring countries. The national energy carrier mixes used for electricity production, the power plant efficiency data, shares on direct to combined heat and power generation (CHP), as well as transmission/distribution losses and own consumption values are taken from official statistics (International Energy Agency, and US-EPA eGRID for USA regions) for the corresponding reference year. Detailed power plant models were used, which combine measured (e.g. NOx) with calculated emission values (e.g. heavy metals). The inventory is partly based on primary industry data, partly on secondary literature data.

Technological representativeness

Technology description including background system: Foreground system: The national or regional specific electricity consumption mix is provided by the conversion of the different energy carriers to electricity and imports from neighbouring countries, as illustrated in the pie chart "Electricity Mix". The electricity is either produced in energy carrier specific power plants and/or combined heat and power plants (CHP). Also considered are the national and regional specific technology standards of the power plants in regard to efficiency, firing technology, flue-gas desulphurisation, NOx removal and de-dusting. The electricity provided by non-combustible renewable energy sources also considers the national or regional situation, such as solar radiation (photovoltaic), annual full load hours (wind power), and share of hydro power stations by type (run-of-river, storage and pumped storage). The fossil power plant models combine emission data from literature with calculated values for non-measured emissions e.g. organics or heavy metals. For the emissions CO₂, SO₂, NO_x, CO, CH₄, N₂O, NMVOC and particulate matter (PM) measured/calculated data are used, taken from national inventory reports, emission inventory data bases, utility companies and other sources. The calculation of other emissions within the models are based on energy carrier properties, transfer coefficients and power plant thermodynamics representing the applied flue gas treatment technologies and standards (flue gas desulphurisation, dust filter etc.). Combustion residues from solid fuels, such as gypsum, bottom ash or fly ash are assumed to be reused e.g. in construction work. Waste treatment for these substances is therefore not considered. Radioactive emissions from ashes are not considered in the coal power plant model. The energy carrier supply considers the whole supply chain of the energy carrier from exploration, production, processing and transport of the fuels to the power plants. The supply chain is modelled in specific national / regional energy carrier consumption mixes (i.e. domestic production and imports), and considers national / regional average energy carrier properties (e.g. elemental composition and energy content).

Included data sets: DE: Electricity from photovoltaic PE [Electricity from photovoltaic], DE: Electricity from wind power PE [Electricity from wind power], DE: Electricity from hydro power PE [Electricity from hydro power], DE: Electricity from waste PE [Electricity from waste], DE: Electricity from biomass PE [Electricity from biomass]

Technical purpose of product or process: Supply of 1 kWh low voltage (< 1kV) electricity to final consumers.

Electricity Mix - DE

Emission factors for power plants > 50 MW DE

Energy carrier specific power plant	Natural gas	Blast furnace gas	Biogas
CO ₂ [kg/TJ fuel input]	56,000	225,000	
CO [kg/TJ fuel input]	1.7	30.4	
SO ₂ [kg/TJ fuel input]	0.4	0.0	
NO _x [kg/TJ fuel input]	44.5	212.4	
In electricity data sets: efficiency electricity plant [%]	52.0	39.7	
In electricity data sets: overall efficiency CHP plant [%]	73.4	49.9	
In electricity data sets: share electricity to thermal energy within CHP plant [%]	53.4	95.4	
In thermal energy data sets: thermal efficiency heat plant [%]	100.0	100.0	
In process steam data sets: thermal efficiency heat plant [%]	85.0 ; 90.0 ; 95.0	85.0 ; 90.0 ; 95.0	85.0 ; 90.0 ; 95.0

Figure 5-1 :Example documentation in GaBi (excerpt) [GABI]

5.3 Validation

The validation procedures of GaBi Databases are implemented on different levels.

1) Consistency and Completeness of database objects

Consistency of flows and completeness of the necessary flow characteristics are validated internally at Sphera, following standard routine. Sphera provides several different databases consistent to our own databases. Routines and technical tools exist therefore to trace and identify possible errors and ensure consistency, completeness and biunique database entries.

2) Content on technical process level

The technical content is constantly validated in LCA work with GaBi data by related industry experts, branch experts or process operators. Validating technical content of datasets needs technical understanding. If companies provide data, Sphera validates the data (because it must fit in detail and consistency to the surrounding system) and, depending on the type and purpose of the data, IABP- University of Stuttgart or a third-party validator or reviewer is involved.

3) Methodological LCI approach

Methodological LCI approaches in GaBi Databases are based on relevant standards and reference works, and are presented and discussed in and benchmarked against different academic, political and professional frameworks (like e.g., ILCD 2010, NETZWERK 2011, PLASTICSEU 2011, UNEP/SETAC 2011, ISO 21930: 2007, PEF METHOD 2019) to ensure acceptance and applicability. A validation of methodological approaches is constantly conducted in the context of the use of GaBi data and process chain details within the given framework and the respective critical reviews of studies, which utilise the databases.

4) Methodological approach LCIA

New impact methods in GaBi are implemented preferably by involving the respective LCIA method developers, to implement the given method in the most suitable way. This implementation includes proactive critical discourse between scientific detail and practical applicability. The validation of the method is preferably conducted jointly by the developers and Sphera.

5) Content on LCI and LCIA level

In many LCA projects, reviews are undertaken and the background data (chains) are reviewed and discussed with the project group and with the reviewer. We grant reviewers access to the background systems under bilateral agreements. Sphera studies, GaBi results and dataset benchmarks are often publicly discussed in external field tests or in comparisons. A broad user community is constantly using, comparing, benchmarking, screening and reviewing GaBi data



and data results, which are published in various channels. User feedback is collected and incorporated into the database management routine.

6 Literature

- AFNOR XP P01-064-CN Association Française de Normalisation (AFNOR), 2014.
- AWARE The AWARE method: Available Water Remaining
<http://www.wulca-waterlca.org/>
- BAITZ 2002 Baitz, M.: Die Bedeutung der funktionsbasierten Charakterisierung von Flächeninanspruchnahmen in industriellen Prozesskettenanalysen. Ein Beitrag zur ganzheitlichen Bilanzierung. Dissertation. Shaker (Berichte aus der Umwelttechnik), Aachen, 2002.
- BOS 2019 Bos, U.: Operationalisierung und Charakterisierung der Flächeninanspruchnahme im Rahmen der Ökobilanz. Forschungsergebnisse aus der Bauphysik, Band 32. Dissertation. Fraunhofer Verlag, ISBN 978-3-8396-1432-7., Stuttgart, 2019.
- BECK, BOS, WITTSTOCK ET AL. 2010 Beck, T.; Bos, U.; Wittstock, B.: LANCA® – Calculation of Land Use Indicator Values in Life Cycle Assessment; 2010 <http://www.lbp-gabi.de/90-1-LANCA.html>.
- BERGER ET AL. 2018 Berger, M.; Eisner, S; van der Ent, R.; Flörke, M.; Link, A.; Poligkeit, J.; Bach, V.; Finkbeiner, M. (2018): Enhancing the Water Accounting and Vulnerability Evaluation Model: WAVE+. Environmental Science and Technology, 52 (18), pp. 10757-10766, doi.org//10.1021/acs.est.7b05164
- BRENTROP ET AL. 2000 Brentrop, F.: Methods to estimate on-field nitrogen emissions from crop production as an input to LCA studies in the Agricultural Sector. The International Journal of Life Cycle Assessment 5(6) 349-357.
- BORKEN ET AL. 1999 Borken, J.; Patyk, A.; Reinhardt, G. A: Basisdaten für ökologische Bilanzierungen – Einsatz von Nutzfahrzeugen in Transport, Landwirtschaft und Bergbau, Braunschweig: Vieweg, 1999.
- BOS ET AL. 2016 Bos, U.; Horn, R.; Beck, T.; Lindner, J. P.; Fischer, M.: LANCA® Characterization Factors for Life Cycle Impact Assessment, Version 2.0; 2016Online: <https://verlag.fraunhofer.de/bookshop/buch/LANCA/244600>.
- CML 2001 CML: CML's impact assessment methods and characterisation factors. Leiden University, Institute of Environmental Science (CML), 2001.
- DE LAURENTIIS ET AL. 2019 De Laurentiis, V., Secchi, M., Bos, U., Horn, R., Laurent, A., Sala, S. (2019): Soil quality index: exploring options for a comprehensive assessment of land use impacts in LCA. Journal of Cleaner Production, Volume 215.
- DREICER ET AL. 1995 Dreicer M., Tort V. and Manen P. (1995): ExternE, Externalities of Energy, Vol. 5 Nuclear, Centre d'étude sur l'Evaluation de la Protection dans le domaine nucléaire (CEPN), edited by the European Commission DGXII, Science, Research and development JOULE, Luxembourg.
- ECO-INDICATOR 95 2000 Eco-indicator 95: A damage oriented method for Life Cycle Impact Assessment Methodology Report nr. 199/36 A, PRé Consultants B.V., Amersfoort, The Netherlands, 2000.
- ECO-INDICATOR 99 2000 Eco-indicator 99: A damage oriented method for Life Cycle Impact Assessment Methodology Report nr. 199/36 A, PRé Consultants B.V., Amersfoort, The Netherlands, 2000.

ECOTRANSIT2010	IFEU Heidelberg, Öko-Institut, IVE / RMCON, EcoTransIT World, Ecological Transport Information Tool for Worldwide Transports: Methodology and Data, Berlin, Hannover, Heidelberg; Germany, 2010.
EMEP/CORINAIR 2002	Joint EMEP/CORINAIR Atmospheric Emission Inventory Guidebook, European Environment Agency, Third Edition, Copenhagen; Denmark, 2002.
EMEP/CORINAIR 2006	EMEP/CORINAIR Emission Inventory Guidebook – 2006, European Energy Agency, 2006.
EMEP/CORINAIR 2006B	EMEP/CORINAIR: Emission Inventory Guidebook: Road Transport, European Environment Agency, Copenhagen, 2006.
EN 15804 2019	Sustainability of construction works – Environmental product declarations – Core rules for the product category of construction products, 2019.
EN 15804 2014	Sustainability of construction works – Environmental product declarations – Core rules for the product category of construction products, 2014.
EPS 2015	EPS: A systematic approach to environmental strategies in product development (EPS). Version 2015 – www.ivl.se/eps .
EUROSTAT 2012	http://epp.eurostat.ec.europa.eu/portal/page/portal/eurostat/home/ .
FANTKE 2016	Fantke, P., Evans, J., Hodas, N., Apte, J., Jantunen, M., Jolliet, O., McKone, T.E. (2016). Health impacts of fine particulate matter. In: Frischknecht, R., Jolliet, O. (Eds.), Global Guidance for Life Cycle Impact Assessment Indicators: Volume 1. UNEP/SETAC Life Cycle Initiative, Paris, pp. 76-99. Retrieved Jan 2017 from www.lifecycleinitiative.org/applying-lca/lcia-cf/ .
FANTKE 2017	Fantke, P., Bijster, M., Guignard, C., Hauschild, M., Huijbregts, M., Jolliet, O., Kounina, A., Magaud, V., Margni, M., McKone, T.E., Posthuma, L., Rosenbaum, R.K., van de Meent, D., van Zelm, R., (2017). USEtox@2.0 Documentation (Version 1.1), http://usetox.org . https://doi.org/10.11581/DTU:00000011
FAO 2012	FAO and JRC: Global forest land-use change 1990–2005 , by E.J. Lindquist, R. D’Annunzio, A. Gerrand, K. MacDicken, F. Achard, R. Beuchle, A. Brink, H.D. Eva, P. Mayaux, J. San-Miguel-Ayanz & H-J. Stibig. FAO Forestry Paper No. 169. Food and Agriculture Organization of the United Nations and European Commission Joint Research Centre. Rome, FAO, 2012.
FINAT 2000	FINAT, A.G.: 2 nd ETAP Forum: Markets for Sustainable Construction. Opening Speech. A. Gonzáles Finat, Director, New and Renewable Sources of Energy, Energy Efficiency & Innovation, DG Transport & Energy, European Commission. Brussels: June 11 th , 2000.
FINKBEINER 2014	Finkbeiner, M.: Indirect land use change, BioResources 9 (3), 3755-3756.
FRISCHKNECHT ET AL. 2008	Frischknecht R., Steiner R. and Jungbluth N. (2008): The Ecological Scarcity method – Eco-Factors 2006. A method for impact assessment in LCA. Environmental studies no. 0906. Federal Office for the Environment (FOEN), Bern. 188 pp
GABI 2019	Sphera AG: GaBi Software-System and Database for Life Cycle Engineering, Leinfelden-Echterdingen, Germany,
GHGPC 2011	GHG Protocol Corporate Value Chain Accounting and Reporting Standard, WRI/WBCSD, 2011.
GHGPP 2011	Product Life Cycle Accounting and Reporting Standard, WRI/WBCSD, 2011.

- GUINÉE ET AL. 1996 LCA impact assessment of toxic releases; Generic modelling of fate, exposure and effect for ecosystems and human beings. (no. 1996/21) Centre of Environmental Science (CML) Leiden and National Institute of Public Health and Environmental Protection (RIVM), Bilthoven, May 1996.
- GUINÉE ET AL. 2001 Guinée, J. et. Al. Handbook on Life Cycle Assessment – Operational Guide to the ISO Standards. Centre of Environmental Science, Leiden University (CML); The Netherlands, 2001.
- GUINÉE ET AL. 2002 Handbook on Life Cycle Assessment: An operational Guide to the ISO Standards; Dordrecht: Kluwer Academic Publishers, 2002.
- HAUSCHILD 2003 Hauschild, M. Z.: Spatial differentiation in life cycle impact assessment – the EDIP-2003 methodology. Guidelines from the Danish EPA Participant(s), Technical University of Denmark, Department of Manufacturing Engineering and Management, Denmark, 2003.
- HBEFA 2010 Handbook Emission Factors for Road Transport (HBEFA), Version 3.1, Umweltbundesamt Berlin; BUWAL / OFEFP Bern; Umweltbundesamt Wien, <http://www.hbefa.net>, Berlin, Bern, Vienna / Germany, Switzerland, Austria, 2010.
- HORN AND MAIER 2018 Horn, R., Maier, S. (2018): Updated Characterization Factors (Version 2.5), <https://www.bookshop.fraunhofer.de/buch/LANCA/244600>.
- IBU 2011 Institut Bauen und Umwelt e.V. (IBU).
- IFEU 2010 IFEU Heidelberg, Energieverbrauch und Schadstoffemissionen des motorisierten Verkehrs in Deutschland 1960-2030 (TREMODO, v5), Heidelberg; Germany, 2010.
- IMO 2015 International Maritime Organization: Third IMO GHG Study 2014, Executive Summary and Final report, 2015.
- IKP 2003 Institut für Kunststoffprüfung und Kunststoffkunde der Universität Stuttgart, Abteilung Ganzheitliche Bilanzierung, 2003.
- ILCD 2010 European Commission-Joint Research Centre – Institute for Environment and Sustainability: International Reference Life Cycle Data System (ILCD) Handbook – General guide for Life Cycle Assessment – Detailed Guidance, European Union, 2010.
- ILCD 2011 European Commission-Joint Research Centre – Institute for Environment and Sustainability: International Reference Life Cycle Data System (ILCD) Handbook – Recommendations for Life Cycle Impact Assessment in the European context. First edition November 2011. EUR 24571 EN. Luxemburg. Publications Office of the European Union; 2011.
- IMPACT 2002 Impact 2002+ : École Polytechnique Fédérale de Lausanne, Lausanne, 2002.
- IPCC 2006 Intergovernmental Panel on Climate Change (IPCC) Revised Guidelines for National Greenhouse Gas Inventories from 2006.
- IPCC 2013 Myhre, G. D.; Shindell, F.-M.; Bréon, W.; Collins, J.; Fuglestedt, J.; Huang, D.; Koch, J.-F.; Lamarque, D.; Lee, B.; Mendoza, T.; Nakajima, A.; Robock, G.; Stephens, T. Takemura and H. Zhang, 2013: Anthropogenic and Natural Radiative Forcing. In: Climate Change 2013: The Physical Science Basis. Contribution of Working Group I to the Fifth Assessment Report of the Intergovernmental Panel on Climate Change [Stocker, T.F.; D. Qin; G.-K. Plattner; M. Tignor; S.K. Allen; J. Boschung; A. Nauels; Y. Xia; V. Bex and P.M. Midgley (eds.)]. Cambridge University Press, Cambridge, United Kingdom and New York, NY, USA.

ISRIC WISE 2002	Batjes, N. H.: ISRIC-WISE – Global Soil Profile Data (ver. 1.1). Wageningen, 2002, Online: http://library.wur.nl/isric/ .
ISO 14040: 2009	ISO 14040: Environmental management – Life cycle assessment – Principles and guidelines, 2009.
ISO 14021: 1999	Environmental labels and declarations – Self-declared environmental claims (Type II environmental labelling), 1999.
ISO 14025: 2006	Environmental labels and declarations – Type III environmental declarations – Principles and procedures, 2006.
ISO 14044: 2006	ISO 14044, Environmental management – Life cycle assessment – Requirements and guidelines, 2006.
ISO 14046	ISO Life cycle assessment – Water footprint – Requirements and guidelines. International Organization for Standardization, 2014.
ISO 14020: 2000	Environmental labels and declarations – General principles, 2000.
ISO 14064-1: 2006	Greenhouse gases – Part 1: Specification with guidance at the organization level for quantification and reporting of greenhouse gas emissions and removals, 2006.
ISO/TS 14067: 2013	ISO/TS 14067, Carbon Footprint of Products, 2013.
ISO 21930: 2007	Sustainability in building construction – Environmental declaration of building products
JOOS ET AL 2013	Joos F.; Roth R.; Fuglestvedt, J. S.; Peters, G. P.; Enting, I. G., Von Bloh, W.; Brovkin, V.; Burke, E. J.; Eby, M.; Edwards, N. R.; Friedrich, T.; Frölicher, T. L.; Halloran, P. R.; Holden, P. B.; Jones, C.; Kleinen, T.; Mackenzie, F. T.; Matsumoto, K.; Meinshausen, M.; Plattner, G.-K.; Reisinger, A.; Segschneider, J.; Shaffer, G.; Steinacher, M.; Strassmann, K.; Tanaka, K.; Timmermann, A.; Weaver, A. J. (2013). Carbon dioxide and climate impulse response functions for the computation of greenhouse gas metrics: a multi-model analysis. Atmospheric Chemistry and Physics, 13(5), 2793-2825.
KREISSIG & KÜMMEL 1999	Kreißig, J. und J. Kümmel: Baustoff-Ökobilanzen. Wirkungsabschätzung und Auswertung in der Steine-Erden-Industrie. Hrsg. Bundesverband Baustoffe Steine + Erden e.V., 1999.
KUPFER 2005	Prognose von Umweltauswirkungen bei der Entwicklung chemischer Anlagen, Dissertation, University of Stuttgart, 2005.
MILA I CANALS 2007	Method for assessing impacts on life support functions (LSF) related to the use of 'fertile land' in Life Cycle Assessment (LCA). Journal of Cleaner Production 15 (2007) 1426-1440.
MITCHELL 2003	Mitchell, T.D.: A comprehensive set of climate scenarios for Europe and the globe. TYN CY 1.1 data-est. Tyndall Centre for Climate Change Research, 2003 Online: http://www.cru.uea.ac.uk/~timm/cty/obs/TYN_CY_1_1.html .
NETZWERK 2011	Netzwerk Lebenszyklusdaten wird am Forschungszentrum Karlsruhe, 2011.
NF P 01 010: 2004	French EPD system: Norme française définissant le contenu et le mode de réalisation de la Fiche de Déclaration Environnementale et Sanitaire dans le cadre des produits de construction, December 2004.
OVID 2013	Finkbeiner, M.; OVID – Verband der Ölsaaten-verarbeitenden Industrie Deutschland/ Verband der Deutschen Biokraftstoffindustrie e.V. (VDB); Indirect Land Use Change (ILUC) within Life Cycle Assessment (LCA) – Scientific Robustness and Consistency with International Standards; 2013

PAS 2050 2011	Specification for the assessment of the life cycle greenhouse gas emissions of goods and services, BSI 2011.
PEF GUIDE 2013	European Commission (EC): COMMISSION RECOMMENDATION of 9 April 2013 on the use of common methods to measure and communicate the life cycle environmental performance of products and organisations (2013/179/EU) ANNEX II PRODUCT ENVIRONMENTAL FOOTPRINT (PEF) GUIDE Official Journal of the European Union Volume 56, L 124, 4.5.2013.
PEF METHOD 2019	Zampori, L. and Pant, R., Suggestions for updating the Product Environmental Footprint (PEF) method, EUR 29682 EN, Publications Office of the European Union, Luxembourg, 2019, ISBN 978-92-76-00654-1, doi:10.2760/424613, JRC115959.
PEFCR GUIDANCE 2017	European Commission (EC): Product Environmental Footprint Guidance – Guidance for the development of Product Environmental Footprint Category Rules (PEFCRs), Version 6.3 – November 2017.
PETERS ET AL. 2014	Improving odour assessment in LCA—the odour footprint. International Journal of Life Cycle Assessment 19:1891–1900, 2014.
PFISTER ET AL. 2009	Pfister, S.; Koehler, A.; Hellweg, S.: Assessing the Environmental Impacts of Freshwater Consumption in LCA. Environmental Science & Technology 43, 2009.
PFLIEGER AND ILG 2007	Pflieger, J.; Ilg, R.: Analyse bestehender methodischer Ansätze zur Berücksichtigung des Recyclings von Metallen im Rahmen der Ökobilanz, Netzwerk Lebenszyklusdaten Arbeitskreis METALLISCHE ROHSTOFFE, Universität Stuttgart/Forschungszentrum Karlsruhe, 2007.
PLASTICSEU 2011	Eco-profiles and Environmental Declarations PlasticsEurope, Version 2.0, April 2011.
POSCH 2008	Posch, M., Seppälä, J., Hettelingh, J.P., Johansson, M., Margni M., Jolliet, O. (2008). The role of atmospheric dispersion models and ecosystem sensitivity in the determination of characterisation factors for acidifying and eutrophying emissions in LCIA. Int J LCA (13) pp.477–486.
RABL AND SPADARO 2004	Rabl, A. and Spadaro, J. V: The RiskPoll software, version is 1.051, dated August 2004. www.arirabl.com .
RECIPE 2012	ReCiPe Mid/Endpoint method, version 1.08 October 2012; Online: http://sites.google.com/site/lciarecipe/characterisation-and-normalisation-factors .
RECIPE 2016	Huijbregts M. A. J. et al 2016. ReCiPe 2016. A harmonized life cycle impact assessment method at midpoint and endpoint level Report I: Characterization. RIVM Report 2016-0104. National Institute for Public Health and the Environment, the Netherlands.
RWTH 1990	Hrsg.: Rhein.-Westf. Technischen Hochschule Aachen: Spezifischer Energieeinsatz im Verkehr, Ermittlung und Vergleich der spezifischen Energieverbräuche, Forschungsbericht FE NR. 90 247/88, Aachen 1990.
SAOUTER 2018	Saouter E., Biganzoli F., Ceriani L., Pant R., Versteeg D., Crenna E., Zampori L. (2018). Using REACH and EFSA database to derive input data for the USEtox model. EUR 29495 EN, Publications Office of the European Union, Luxembourg, ISBN 978-92-79-98183-8, doi: 10.2760/611799, JRC 114227.
SEPPALA 2006	Seppälä, J., Posch, M., Johansson, M., Hettelingh, J.P. (2006). Country-dependent Characterisation Factors for Acidification and Terrestrial Eutrophication Based on Accumulated Exceedance as an Impact Category Indicator. Int J LCA 11(6): 403-416.

- SCHNEIDER 2011 Schneider, L., Berger, M. and Finkbeiner, M.: The anthropogenic stock extended abiotic depletion potential (AADP) as a new parameterization to model the depletion of abiotic resources; International Journal of Life Cycle Assessment (2011) 16:929–936, 2011.
- SCHWARZ ET AL. 1999 Schwarz, Winfried and Leisewitz, André: Emissionen und Minderungspotential von HFKW, FKW und SF6 in Deutschland, Im Auftrag des Umweltbundesamtes, Forschungsbericht 29841256, Frankfurt, 1999.
- SEPPÄLÄ ET AL. 2006 Country-Dependent Characterisation Factors for Acidification and Terrestrial Eutrophication Based on Accumulated Exceedance as an Impact Category Indicator. Int J LCA 11 (6) 403 – 416, 2006.
- STRUJIS ET AL. 2009 Struijs J., Beusen A., van Jaarsveld H. and Huijbregts M.A.J. (2009): Aquatic Eutrophication. Chapter 6 in: Goedkoop M., Heijungs R., Huijbregts M.A.J., De Schryver A., Struijs J., Van Zelm R. (2009): ReCiPe 2008 - A life cycle impact assessment method which comprises harmonised category indicators at the midpoint and the endpoint level. Report I: Characterisation factors, first edition.
- THYLMANN 2017 Thylmann, D., Kupfer, T.: Introduction to Water Assessment in GaBi Software, Version 2.0, 2017 <http://www.gabi-software.com/deutsch/support/latestupdate>
- TRACI 2012 Traci, Tool for Reduction and Assessment of Chemical and other environmental Impacts 2.1 (Traci), U.S. Environmental Protection Agency, 2012; Online: <http://www.epa.gov/nrmrl/std/sab/traci/>.
- TRACI 1996 TRACI: The Tool for the Reduction and Assessment of Chemicals and other environmental Impacts, US Environmental Protection Agency, U.S.A., 1996.
- UBA BERLIN 2004 UBA Berlin, BUWAL / OFEFP Bern, Umweltbundesamt Wien: Handbuch Emissionsfaktoren des Straßenverkehrs, Version 2.1, Berlin, 2004.
- UBP 2013 Swiss Eco-Factors 2013 according to the Ecological Scarcity Method. Federal Office for the Environment FOEN. Bern, 2013. <http://www.bafu.admin.ch/publikationen/publikation/01750>.
- UNEP/SETAC 2011 UNEP/SETAC: Global Guidance Principles for Life Cycle Assessment Databases – A basis for greener processes and products, 2011.
- UNEP/SETAC 2016 UNEP: UNEP-SETAC Life Cycle Initiative (2016) – Global Guidance for Life Cycle Impact Assessment Indicators. Volume 1. ISBN: 978-92-807-3630-4. Available at: <http://www.lifecycleinitiative.org/life-cycle-impact-assessment-indicators-andcharacterization-factors/>
- USETOX 2010 Rosenbaum, R. K. et al: USEtox – The UNEP/SETAC-consensus model: recommended characterisation factors for human toxicity and freshwater ecotoxicity in Life Cycle Impact Assessment. International Journal of Life Cycle Assessment 13(7): 532-546., 2008; USEtox™ model 1.01 and organic database 1.01, 2010.
- VAN OERS ET AL. 2002 Van Oers L., de Koning A., Guinee J.B. and Huppes G. (2002): Abiotic Resource Depletion in LCA. Road and Hydraulic Engineering Institute, Ministry of Transport and Water, Amsterdam.
- VAN ZELM ET AL. 2008 Van Zelm R., Huijbregts M.A.J., Den Hollander H.A., Van Jaarsveld H.A., Sauter F.J., Struijs J., Van Wijnen H.J. and Van de Meent D. (2008): European characterisation factors for human health damage of PM10 and ozone in life cycle impact assessment. Atmospheric Environment 42, 441-453.

- VBD 2003 Personal information: Versuchsanstalt für Binnenschiffbau e.V. (VBD), 2003 (renamed 2004 in Entwicklungszentrum für Schiffstechnik und Transportsysteme e.V. (DST)).
- WOLF&EYERER 2002 Wolf M.-A., Eyerer P. (2002): LCI modeling of renewable resource production systems; sensitivity analysis, scenario calculation, and Monte-Carlo-Simulation. Oral presentation and short paper in: Proceedings of the fifth International Conference on EcoBalance, Nov. 6 - Nov. 8 2002 Tsukuba, Japan.
- WORLD BANK 2012 <http://databank.worldbank.org/data/Databases.aspx>
- WMO 2014 World Meteorological Organisation (WMO) (2014), Scientific Assessment of Ozone Depletion: 2014, Global Ozone Research and Monitoring Project Report No. 55, Geneva, Switzerland, 2014.
- WSI, 2009 Pfister, S., Koehler, A., & Hellweg, S. (2009). Assessing the environmental impacts of freshwater consumption in LCA. Environmental science & technology, 43(11), 4098-4104.

7 Appendix A Description of result and impact categories

This chapter very briefly describes the impact assessment methodologies available in GaBi after the update 2020 (called quantities in the GaBi software). The description is divided into overall impact categories (e.g., global warming, acidification.) and the approach of each of the available impact methodologies (e.g., CML, ReCiPe) is described.

Methods covering only specific impact categories, e.g., USETox for toxicity and IPCC for global warming, are described under each impact category.

The description is focused on the LCIA methodologies, but most of the complete LCIA methodologies draw on background LCIA models and methods for each of the environmental impacts. Examples relating back to the original primary sources are listed in Table L for GWP.

Table L: LCIA GWP methods with primary sources

Impact	LCIA Methodology	Primary source – LCIA model/method
GWP	CML2001 version 4.8, August 2016	IPCC 2013 AR5, Table 8.A.1, GWP 100
GWP	EDIP 2003	TAR Climate Change 2001: The Scientific Basis (Third Assessment Report (TAR) from IPCC)
GWP	Environmental Footprinting; EF 2.0 and EF 3.0	IPCC 2013 AR5, Table 8.A.1, GWP 100
GWP	EN15804+A1	(CML-2013) IPCC 2007 AR4, Table 2.14.
GWP	EN15804+A2	(EF 3.0) IPCC 2013 AR5, Table 8.A.1, GWP 100; with different accounting of biogenic carbon compared to EF 3.0
GWP	IPCC 2013	IPCC 2013 AR5, Table 8.A.1, GWP 100
GWP	ISO 14067	IPCC 2013 AR5, Table 8.A.1, GWP 100
GWP	ReCiPe 2016 (H) v1.1, GWP 100	IPCC 2013 AR5, including climate carbon feedback. Table 8.7 and supplementary material table 8.SM.15.
GWP	ReCiPe 2016 (I) v1.1, GWP 20	AR5, Table 8.A.1, GWP 20 (excluding climate carbon feedback)
GWP	ReCiPe 2016 (E) v1.1, GWP 1000	Joos et al 2013

GWP	TRACI 2.1	IPCC 2007 AR4, Table 2.14.
GWP	UBP 2013	IPCC 2007 AR4, Table 2.14.

The International Reference Life Cycle Data System (ILCD) published 'Recommendations for Life Cycle Impact Assessment in the European context', which recommends the methodology evaluated as the best within the impact category [ILCD 2011]. This led to the set of impact categories that time available as 'Impacts ILCD/PEF recommendation v1.09' in GaBi.

During the Environmental Footprint (EF) framework, the ILCD work has been further developed and the latest version from the JRC is currently available under 'EF 3.0' in GaBi. The preceding version EF 2.0 is kept as it is since it is used for the first set of PEFCRs/OEFSRs which were developed in the EF pilot phase 2013-2019.

IMPORTANT NOTE, Environmental footprint impact methods:

With release of the GaBi Databases 2019 Edition (February 2019), the official EF 2.0 characterization factors are provided, as well as the mapping to the official units and official elementary flows via the ILCD export/import function.

Since release of the GaBi Service Pack 39 2019 (July 2019), the official EF 3.0 characterization factors are being provided.

EF 2.0 is the only version to be used for PEF/OEF results and to create EF data as ILCD export file. Do not use previous versions of EF characterization factors and ILCD zip archives anymore! Earlier versions of EF/ILCD LCIA methods and flow lists have no official status and datasets developed with earlier versions may not be claimed EF-conformant. **In case you have been using a previous version of EF characterization factors, please update any created dataset by re-export, respectively re-calculate results using the EF 2.0 in GaBi (datasets created by users should also be double-checked with recent official EF documents, before claiming conformance).** In case you need any support with this topic, please contact gabi-data@sphera.com.

EF 3.0 is used for developments during the ongoing European Commission's EF transition phase (i.e., for model and PEFCR development) until early 2022.

The EF 2.0 LCIA methods are outlined in Table M. The approach of each method is described in the appropriate chapter.

Table M: EF 2.0: set of recommended impact methods

Method	Description
Acidification	Accumulated Exceedance (AE). Change in critical load exceedance of the sensitive area in terrestrial and main freshwater ecosystems.
Climate Change - total	Global Warming Potential 100 years, based on IPCC AR5 including climate carbon feedback
Climate Change, biogenic	These are subsets of the total Climate Change covering the biogenic, fossil, and land use related part of the climate change. These three add up to the main climate change impact.
Climate Change, fossil	
Climate Change, land use and land use change	
Ecotoxicity, freshwater	Comparative Toxic Unit for ecosystems (CTUe). The potentially affected fraction of species (PAF) integrated over time and volume per unit mass of a chemical emitted (PAF m ³ year/kg).
Eutrophication, freshwater	Phosphorus equivalents: The degree to which the emitted nutrients reach the freshwater end compartment (phosphorus considered as limiting factor in freshwater).
Eutrophication, marine	Nitrogen equivalents: The degree to which the emitted nutrients reach the marine end compartment (nitrogen considered as limiting factor in marine water).
Eutrophication, terrestrial	Accumulated Exceedance (AE). The change in critical load exceedance of the sensitive area.
Human toxicity, cancer	Comparative Toxic Unit for human (CTUh). Estimated increase in morbidity in the total human population per unit mass of a chemical emitted (cases per kilogramme).
Human toxicity, non-cancer	Comparative Toxic Unit for human (CTUh). The estimated increase in morbidity in the total human population per unit mass of a chemical emitted (cases per kilogramme).
Ionising radiation, human health	Ionizing Radiation Potentials: The impact of ionizing radiation on the population, in comparison to Uranium 235.
Land Use	Soil quality index based on the LANCA methodology and respective characterization factors V2.3.
Ozone depletion	Ozone Depletion Potential (ODP) calculating the destructive effects on the stratospheric ozone layer over a time horizon of 100 years.
Particulate matter	Deaths due to kg of PM2.5 emitted. The unit is changed into 'Disease incidents' rather than 'Deaths'. However, the change happened after the beginning of the February 2018 update procedure and the change is not implemented until later in 2018
Photochemical ozone formation, human health	Photochemical ozone creation potential (POCP): Expression of the potential contribution to photochemical ozone formation.
Resource use, fossils	Abiotic resource depletion fossil fuels (ADP-fossil)
Resource use, mineral and metals	Abiotic resource depletion (ADP ultimate reserve).
Water use	m ³ water eq. deprived

Table N: EF 3.0: set of recommended impact methods

Method	Description
Acidification	Accumulated Exceedance (AE). Change in critical load exceedance of the sensitive area in terrestrial and main freshwater ecosystems.
Climate Change - total	Global Warming Potential 100 years, based on IPCC AR5 including climate carbon feedback
Climate Change, biogenic	These are subsets of the total Climate Change covering the biogenic, fossil, and land use related part of the climate change. These three add up to the main climate change impact.
Climate Change, fossil	
Climate Change, land use and land use change	
Ecotoxicity, freshwater - total	Comparative Toxic Unit for ecosystems (CTUe). The potentially affected fraction of species (PAF) integrated over time and volume per unit mass of a chemical emitted (PAF m ³ year/kg).
Ecotoxicity, freshwater inorganics	
Ecotoxicity, freshwater metals	
Ecotoxicity, freshwater organics	
Eutrophication, freshwater	Phosphorus equivalents: The degree to which the emitted nutrients reach the freshwater end compartment (phosphorus considered as limiting factor in freshwater).
Eutrophication, marine	Nitrogen equivalents: The degree to which the emitted nutrients reach the marine end compartment (nitrogen considered as limiting factor in marine water).
Eutrophication, terrestrial	Accumulated Exceedance (AE). The change in critical load exceedance of the sensitive area.
Human toxicity, cancer - total	Comparative Toxic Unit for human (CTUh). Estimated increase in morbidity in the total human population per unit mass of a chemical emitted (cases per kilogramme).
Human toxicity, cancer inorganics	
Human toxicity, cancer metals	
Human toxicity, cancer organics	
Human toxicity, non-cancer - total	Comparative Toxic Unit for human (CTUh). The estimated increase in morbidity in the total human population per unit mass of a chemical emitted (cases per kilogramme).
Human toxicity, non-cancer inorganics	
Human toxicity, non-cancer metals	
Human toxicity, non-cancer organics	
Ionising radiation, human health	Ionizing Radiation Potentials: The impact of ionizing radiation on the population, in comparison to Uranium 235.
Land Use	Soil quality index based on the LANCA methodology and respective characterization factors V2.5.

Method	Description
Ozone depletion	Ozone Depletion Potential (ODP) calculating the destructive effects on the stratospheric ozone layer over a time horizon of 100 years.
Particulate Matter	Impact on human health (disease incidence)
Photochemical ozone formation, human health	Photochemical ozone creation potential (POCP): Expression of the potential contribution to photochemical ozone formation.
Resource use, fossils	Abiotic resource depletion fossil fuels (ADP-fossil)
Resource use, mineral and metals	Abiotic resource depletion (ADP ultimate reserve).
Water use	m ³ water eq. deprived

7.1 Primary energy consumption

Primary energy demand (PED) is often difficult to determine due to the various types of energy sources. Primary energy demand is the quantity of energy directly withdrawn from the hydrosphere, atmosphere or geosphere or energy source without any anthropogenic changes. For fossil fuels and uranium, PED would be the amount of resources withdrawn expressed in their energy equivalents (i.e., the energy content of the raw material). For renewable resources, the energy characterised by the amount of biomass consumed would be described. PED for hydropower would be based on the amount of energy that is gained from the change in the potential energy of the water (i.e., from the height difference). The following primary energies are designated as aggregated values:

The total **“Primary energy consumption non-renewable,”** given in MJ, essentially characterises the gain from the energy sources: natural gas, crude oil, lignite, coal and uranium. Natural gas and crude oil will be used both for energy production and as material constituents, such as in plastics. Coal will primarily be used for energy production. Uranium will only be used for electricity production in nuclear power stations.

The total **“Primary energy consumption renewable,”** given in MJ, is generally accounted for separately and comprises hydropower, wind power, solar energy and biomass.

It is important that end use energy (e.g., 1 kWh of electricity) and primary energy are not confused with each other; otherwise, the efficiency loss in production and supply of the end energy will not be accounted for.

The energy content of the manufactured products will be considered feedstock energy content. It represents the still-usable energy content that can be recovered, for example, by incineration with energy recovery.

The primary energy consumption is available both as gross and net calorific value. The **“Gross calorific value”** represents the reaction where all the products of combustion are returned to the original pre-combustion temperature, and in particular condensing water vapour produced.

The **net calorific value** is the higher heating value minus the heat of vaporization of the water. The energy required to vaporize the water is not recovered as heat. This is the case for standard combustion processes where this re-condensation takes place in the surrounding environment. Table O below gives an overview of the primary energy categories present in GaBi.

Table O: Net and gross calorific value

	Non-renewable resources	+	Renewable resources	=	Total
Gross calorific value	Primary energy from non ren. resources (gross cal. value)	+	Primary energy from renewable raw materials (gross cal. value)	=	Primary energy demand from ren. and non ren. resources (gross cal. value)
Net calorific value	Primary energy from non ren. resources (net cal. value)	+	Primary energy from renewable raw materials (net cal. value)	=	Primary energy demand from ren. and non ren. resources (net cal. value)

7.2 Waste categories

In GaBi background databases waste is further treated for known waste pathways towards final emissions in incinerators or landfill bodies if suitable indications exist (e.g., according to waste directives).

If specific wastes are deposited without further treatment, they are indicated with the addition “deposited.”

If waste treatment routes are unknown, unspecific or not definable, GaBi documents the related specific waste flow and the specific waste amount with a waste star “*” meaning it can be further treated if the user knows the specific waste treatment pathway. Categories such as stockpile goods, consumer waste, hazardous waste and radioactive waste, group those specific waste flows together.

7.3 Climate Change – Global Warming Potential (GWP) and Global Temperature Potential (GTP)

The mechanism of the greenhouse effect can be observed on a small scale, as the name suggests, in a greenhouse. These effects also occur on a global scale. The occurring short-wave radiation from the sun comes into contact with the earth’s surface and is partially absorbed (leading to direct warming) and partially reflected as infrared radiation. The reflected part is absorbed by greenhouse gases in the troposphere and is re-radiated in all directions, including back to earth. This results in a warming effect at the earth’s surface.

In addition to the natural mechanism, the greenhouse effect is enhanced by human activities. Greenhouse gases, believed to be anthropogenically caused or increased, include carbon dioxide, methane and CFCs. Figure A-1 shows the main processes of the anthropogenic

greenhouse effect. An analysis of the greenhouse effect should consider the possible long term global effects.

The global warming potential is calculated in carbon dioxide equivalents (CO₂-Eq.), meaning that the greenhouse potential of an emission is given in relation to CO₂. Since the residence time of gases in the atmosphere is incorporated into the calculation, a time range for the assessment must also be specified. A usual period is 100 years.

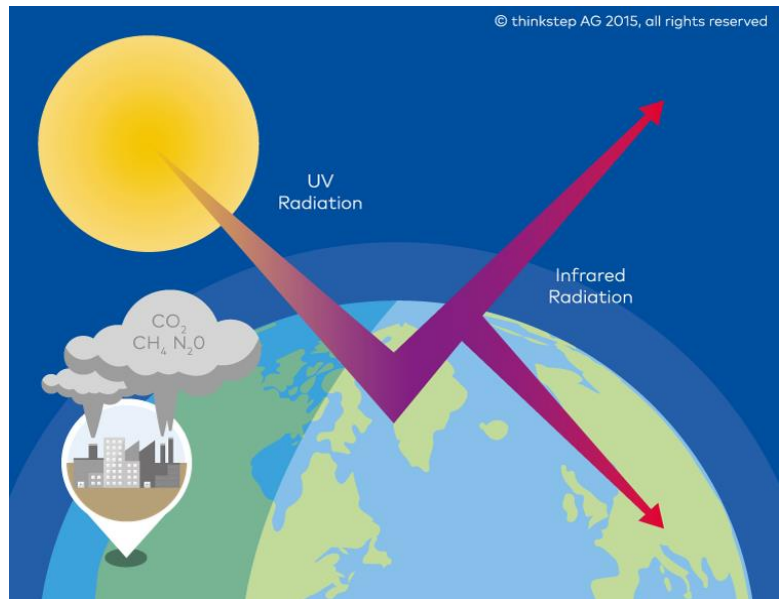

Figure A-1:Greenhouse effect

Biogenic carbon

For the comfort of the user, we applied some frequently used impact methods of “Global Warming Potential” (like CML and IPCC) with both approaches, including and excluding biogenic carbon flows. If biogenic carbon as an emission is accounted for, the respective CO₂ uptake from air (modelled as resources) is consistently modelled as well. Before interpreting and communicating results, the user should check for the specific goal, scope and modelling approach in his application case and choose an appropriate version.

If carbon uptake is released later as biogenic CO₂ or methane this is also accounted for; CO₂ with the factor 1 and methane with a factor 25-30 kg CO₂ eq./kg (depending on methodology). The carbon can also be stored e.g., in wood in buildings.

Excluding biogenic carbon means that CO₂ taken up by plants is excluded from the calculation; in practice by leaving it out of the calculation methods or giving it a factor 0. The same will be the case for biogenic CO₂ emission; it is left out or with a factor 0.

If the carbon is released as biogenic methane this necessitates an adjustment of the emission factor. The argument is that if we model carbon dioxide uptake which is later released as methane, then we need to have a 1:1 molar carbon balance. We therefore need:

$$1 \text{ mole CO}_2 = 44 \text{ g} : 1 \text{ mole CH}_4 = 16 \text{ g}$$

$$2.75 \text{ g CO}_2 : 1 \text{ g CH}_4$$

Consider a plant that sequesters 2.75 kg CO₂ and this carbon is eventually entirely released as 1 kg methane. If we model this system including the sequestered carbon, then the GWP calculation will be as follows:

- Sequestered CO₂ = 2.75 kg=> -2.75 kg CO₂eq
- Emission of CH₄ = 1 kg=> 25 kg CO₂eq
- Net emission = 25 - 2.75=> 22.25 kg CO₂eq

Therefore, if we set the sequestered CO₂ to zero, we need to give the biogenic CH₄ an emission factor of 22.25 kg CO₂ eq. to have the proper net emission factor when starting with a factor of 25kg CO₂ eq.

An overview of the GWP methods including and excluding biogenic carbon is given in Table P below. The Net CH₄ effect is the example calculated above.

Table P: Global warming incl. and excl. biogenic carbon, land use and aviation

Overall method	Specific version	Fossil emission	Biogenic		Land use change	Aviation
			CO ₂ uptake; CO ₂ + CH ₄ emis.	Net CH ₄ effect		
CML 2010- 2016	CML 2001 - Jan. 2016, Global Warming Potential (GWP 100 years)	x	x			x
	CML 2001 - Jan. 2016, Global Warming Potential (GWP 100 years), excl. biogenic carbon	x		x		x
	CML 2001 - Jan. 2016, Global Warming Potential (GWP 100 years), excl. bio. C, incl LUC, no norm/ weight	x		x	x	x
	CML 2001 - Jan. 2016, Global Warming Potential (GWP 100 years), incl. bio. C, incl LUC, no norm/ weight	x	x		x	x
	CML 2001 - Jan. 2016, Global Warming Potential (GWP 100 years), Land Use Change only, no norm/ weight				x	
EF	EF 2.0 + 3.0 Climate Change	x		x	x	
	EF 2.0 + 3.0 Climate Change (biogenic)			x		
	EF 2.0 + 3.0 Climate Change (fossil)	x				
	EF 2.0 + 3.0 Climate Change (land use change)				x	
EN 15804+A1	EN 15804 - Global Warming Potential (GWP)	x	x			x
EN 15804+A2	EN15804+A2 Climate Change	x		x	x	
	EN15804+A2 Climate Change (biogenic)			x		
	EN15804+A2 Climate Change (fossil)	x				
	EN15804+A2 Climate Change (land use change)				x	
EPS	EPS d and dx	x	CH ₄ only		x	x
IO2	IO2 + v2.1 - Global Warming 500yr - Midpoint					
IPCC	IPCC AR5 GWP 100, excl biogenic carbon	x		x		x
	IPCC AR5 GWP 100, excl biogenic carbon, incl Land Use Change, no norm/ weight	x		x	x	x
	IPCC AR5 GWP 100, incl biogenic carbon	x	x			x
	IPCC AR5 GWP 100, incl biogenic carbon, incl Land Use Change, no norm/ weight	x	x		x	x
	IPCC AR5 GWP 100, Land Use Change only, no norm/ weight				x	
ISO 14067	ISO 14067 GWP 100, Fossil	x				
	ISO 14067 GWP 100, Biotic		x			
	ISO 14067 GWP 100, Land Use				x	
	ISO 14067 GWP 100, Aviation					x
ReCiPe I, H, E	ReCiPe 2016 v1.1 Midpoint (H) - Climate change, default, excl biogenic carbon	x		x		
	ReCiPe 2016 v1.1 Midpoint (H) - Climate change, incl biogenic carbon	x	x			
	ReCiPe 2016 v1.1 Midpoint (H) - Climate change, excl. biog. C, incl LUC, no norm/ weight	x		x	x	
	ReCiPe 2016 v1.1 Midpoint (H) - Climate change, incl. biog. C, incl LUC, no norm/ weight	x	x		x	
	ReCiPe 2016 v1.1 Midpoint (H) - Climate change, LUC only, no norm/ weight				x	
TRACI	TRACI 2.1, Global Warming Air, excl. biogenic carbon	x		x		
	TRACI 2.1, Global Warming Air, incl. biogenic carbon	x	x			
	TRACI 2.1, Global Warming Air, excl. biogenic carbon, incl LUC, no norm/ weight	x		x	x	
	TRACI 2.1, Global Warming Air, incl. biogenic carbon, incl LUC, no norm/ weight	x	x		x	
	TRACI 2.1, Global Warming Air, LUC only, no norm/ weight				x	
UBP	UBP 2013, Global Warming	x				x
	UBP 2013, Global Warming, incl Land Use Change	x			x	
	UBP 2013, Global Warming, Land Use Change only				x	

IPCC

All LCIA methodologies have GWP factors, which have been determined from the International Panel on Climate Change (IPCC) as the basis of the GWP factors.

The entire set of factors from IPCC has been implemented; Global Warming Potential (GWP) with the time horizons of 20 and 100 years and Global Temperature Potential (GTP) with the time horizons of 20, 50, and 100 years [IPCC 2013].

GTP is modelling one step further in the cause-effect chain to give the result of temperature change following greenhouse gas emissions.

Two specific IPCC lists of GWP factors are available in GaBi based on Assessment Report 5 (AR5) [IPCC 2013]; one includes biogenic carbon and one excludes it.

EF (Environmental Footprint)

The EF climate change operates with GWP factors from AR5 with additional inclusion of climate carbon feedback. The EF climate change category provides subsets to separately assess the biogenic, fossil, and land use related part of the climate change. These three add up to the main climate change impact.

CML

CML uses the GWP factors published by IPCC. Several time perspectives are available (GWP20, GWP100, GWP500) with the GWPs for 100 years recommended as the baseline characterization method for climate change. In the implementation of the CML version in August 2016²³, the GWP factors are upgraded to AR5; earlier methods are based on Assessment Report 4 (AR4).

By default, CML includes biogenic carbon at the same level as fossil carbon, hence CO₂ uptake has a GWP of 1 kg CO₂ eq., and the subsequent release has the factor of 1 kg CO₂ eq. An additional version excluding biogenic carbon is implemented.

ReCiPe

ReCiPe 2016 [RECIPE 2016] was released in late 2016 and implemented in GaBi in 2017. An upgrade, ReCiPe 2016 v.1.1, was implemented in GaBi in 2018.

The ReCiPe methodology operates with both mid-point and end-point indicators:

²³ The CML version January 2016 is actually based on AR5 as well and implemented in GaBi. In this version CML had implemented AR5 with errors. These were corrected in CML Aug 2016.

Midpoint:

All three cultural perspectives of ReCiPe are included:

- Individual (I) uses the shortest time frame as the GWP20 values from AR5 [IPCC 2013]
- Hierarchical (H) covers what is considered the default timeframe of 100 years (GWP100) supplemented with Climate-carbon feedbacks from the supplementary material of AR5 [IPCC 2013].
- Egalitarian (E) operates with longest possible timeframe of 1000 years (GWP1000) as calculated by [JOOS ET AL 2013].

As default, ReCiPe operates excluding biogenic carbon and hence the biogenic methane has a slightly reduced GWP factor, like the calculation above.

A secondary GWP impact including biogenic carbon is added for each cultural perspective. This means including CO₂ uptake and biogenic CO₂ emission, plus giving biogenic methane emission a characterization factors identical to the fossil versions.

Endpoint

ReCiPe have three end-point categories; human health, terrestrial ecosystems, and aquatic ecosystems. Figure A-2 depicts the impact pathway of the mid- and endpoint factor [ReCiPe 2016]

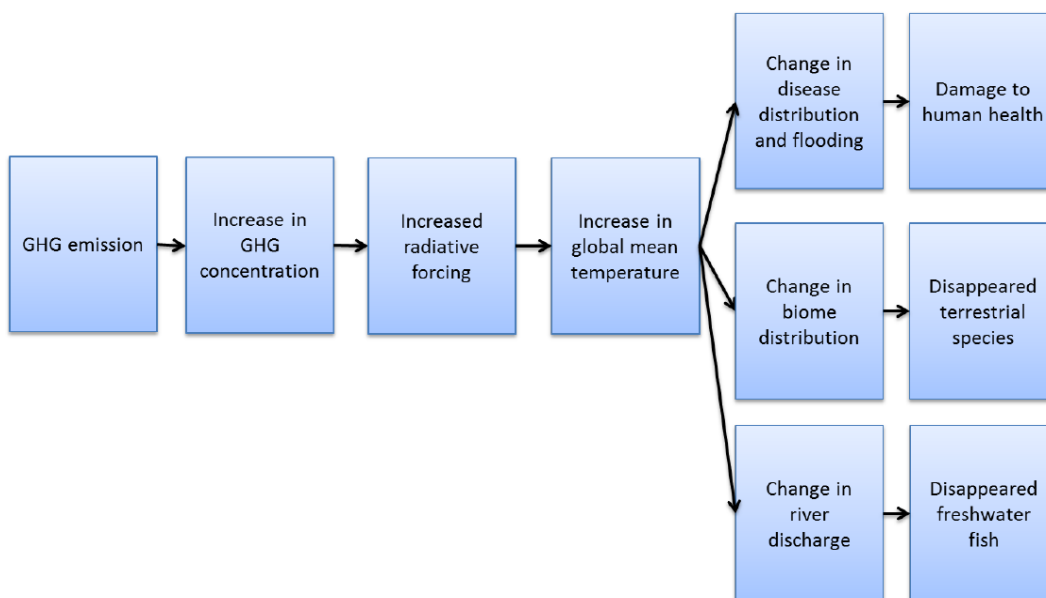

Figure A-2: Greenhouse effect impact pathway chain

Similarly to the midpoint method, an additional GWP method is implemented including biogenic carbon. The CO₂ uptake and biogenic CO₂ emission is given the same characterization factor as fossil CO₂ emission and the biogenic methane CF is changed to that of fossil methane.

TRACI 2.1

TRACI was updated to version 2.1 in the summer of 2012. The methodology utilises global warming potentials (GWPs) to calculate the potency of greenhouse gases relative to CO₂, according to the Assessment Report 4 (AR4) from IPCC. The default TRACI 2.1 method includes biogenic carbon emissions and uptakes. Similarly to CML and ReCiPe, the default version is supplied with the counterpart – here being TRACI GWP excluding biogenic carbon. CO₂ uptakes and biogenic CO₂ emissions are excluded, but based on correspondence with the authors of the TRACI 2.1 method the biogenic methane keeps the same CF as fossil methane emissions.

UBP 2013, Ecological Scarcity Method

The “ecological scarcity” method permits impact assessment of life cycle inventories according to the “distance to target” principle.

Eco-factors, expressed as eco-points per unit of pollutant emission or resource extraction, are normalised and weighted according to Swiss national policy targets, as well as international targets supported by Switzerland. For global warming, the Kyoto protocol governs the reduction target, and the IPCC factors translate into the other greenhouse gases [UBP 2013].

Biogenic CO₂ is excluded both on uptake and emission. However, biogenic methane is included with the same emission factors as fossil methane.

EPS 2015d(x)

The EPS method calculates Environmental Load Units equal to one Euro of environmental damage cost per kg emission including the gases contributing to climate change. For several of the halogenated substances there is a contribution to both ozone depletion and climate change. The cost represent the combined damage cost [EPS 2015].

Biogenic CO₂ is excluded both on uptake and emission. However, biogenic methane is included with the same emission factors as fossil methane.

EDIP 2003

The criteria applied in the EDIP methodology to determine if a substance contributes to global warming follow the IPCC’s recommendation. At one point, the EDIP method goes further than the IPCC’s recommendation by including contribution from organic compounds and carbon monoxide of petrochemical origin, which is degraded to CO₂ in the atmosphere. CO₂ emissions are evaluated for whether they constitute a net addition of CO₂ to the atmosphere, and not what they derive from fossil carbon sources, but rather from biomass, and simply represent a manipulation of part of the natural carbon cycle. [HAUSCHILD 2003]

EcolIndicator99

EcolIndicator99 works with three damage-oriented categories: Human health, ecosystem quality and resources. These categories are subdivided into mid-point indicators falling under human health impact from climate change, which here is considered equivalent to global warming. [GUINÉE ET AL. 2001]

The health-indicator is expressed as the number of Disability-Adjusted Life Years (DALYs), measuring the total amount of ill health, due to disability and premature death, attributable to specific diseases and injuries. The methodology document mentions several possible effects from climate change of which three are included in the impact classification:

- Exposure to thermal extremes with the outcome of altered rates of heat- and cold-related illnesses and death
- Effects on range and activity of vectors and infective parasites with subsequent disease incidences
- Sea-level rise, with population displacement and damage to infrastructure, and with the outcome of an increased risk of infectious disease and psychological disorders

These effects appear in one calculation factor of a number of DALYs per kg of substance emission.

Impact 2002+

The Impact 2002+ methodology operates with the same three damage-oriented impact categories as EcolIndicator99: Human health, ecosystem quality and resources. However, from the authors' point of view, the modelling up to the damage of the impact of climate change on ecosystem quality and human health is not accurate enough to derive reliable damage characterization factors. The interpretation, therefore, directly takes place at midpoint level, making global warming a stand-alone endpoint category with units of kg of CO₂-equivalents. The assumed time horizon is 500 years to account for both short and long-term effects. [IMPACT 2002]

7.4 Acidification Potential (AP)

The acidification of soils and waters occurs predominantly through the transformation of air pollutants into acids. This leads to a decrease in the pH-value of rainwater and fog from 5.6 to 4 and below. Sulphur dioxide and nitrogen oxide and their respective acids (H₂SO₄ und HNO₃) produce relevant contributions. Ecosystems are damaged, so forest dieback is the most well-known impact as indicated in Figure A-3.

Acidification has direct and indirect damaging effects (such as nutrients being washed out of soils or an increased solubility of metals into soils). But even buildings and building materials

can be damaged. Examples include metals and natural stones, which are corroded or disintegrated at an increased rate.

When analyzing acidification, it should be considered that although it is a global problem, the regional effects of acidification can vary.

CML

The acidification potential is given in sulphur dioxide equivalents ($\text{SO}_2\text{-Eq.}$). The acidification potential is described as the ability of certain substances to build and release H^+ ions. Certain emissions can also have an acidification potential, if the given S-, N- and halogen atoms are set in proportion to the molecular mass of the emission. The reference substance is sulphur dioxide.

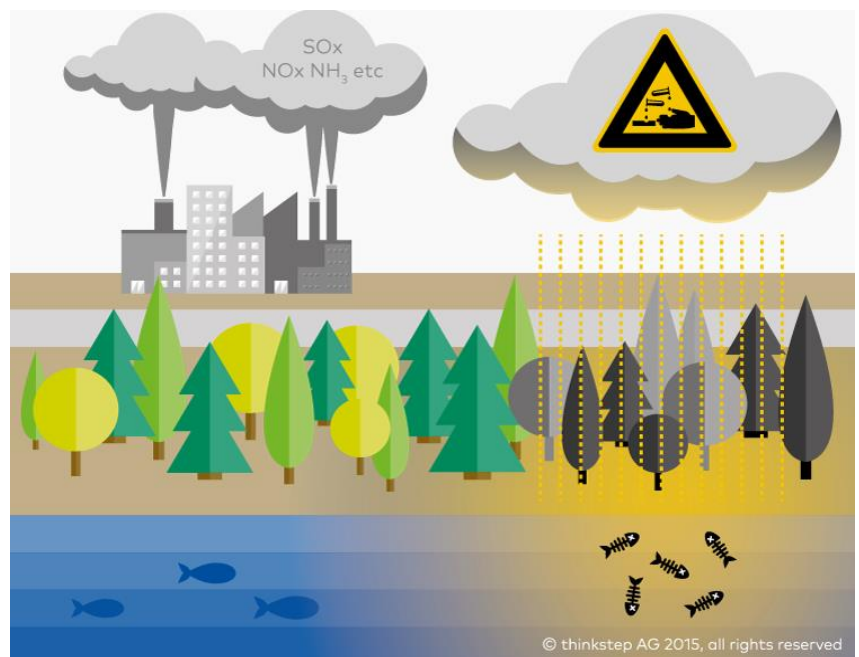

Figure A-3: Acidification Potential

The average European characterization factors of [CML 2001] are currently recommended as the best available practise. Regional factors have not been adopted as the baseline, because it is not always possible, nor desirable, to consider differences between emission sites in LCA.

It is therefore important that emission site-independent characterization factors become available, even for those impact categories for which local sensitivity is important. [GUINÉE ET AL. 2001]

EF (Environmental Footprint)

The EF setup uses Accumulated Exceedance (AE). AE uses atmospheric models to calculate the deposition of released acidifying and eutrophying substance per release country and relates this value to the capacity of the receiving soil to neutralize the effects. The method integrates both the exceeded area and amount of exceedance per kg of released substance [SEPPALA 2006 and POSCH 2008]. In GaBi, only a global value for the acidification is implemented.

ReCiPe

The ReCiPe methodology in version 1.08 and version 2016 v 1.1 uses SO₂-Eq. as in the CML methodology for a midpoint indicator. The Potentially Disappeared Fraction (PDF) of species in forest ecosystems on a European scale is used as endpoint indicator, which is similar to the EcoIndicator99 approach. [RECIPE 2012; RECIPE 2016]

TRACI 2.1

TRACI 2.1 utilises the existing TRACI methodology for acidification plus some additional substances. The calculations are performed for US conditions and the reference substance is kg SO₂ eq. [TRACI 2012]

UBP 2013, Ecological Scarcity Method

The method has adapted CML values as the approach for acidification [UBP 2013]

EPS 2015d(x)

The EPS method calculates Environmental Load Units equal to one Euro of environmental damage cost per kg of emission that are evaluated to have an acidification effect [EPS 2015].

EDIP 2003

Site-generic factors have been established as well as site-dependent factors for 44 European countries or regions. The acidification factors relate an emission by its region of release to the acidifying impact on its deposition areas.

The application of the EDIP2003 site-*generic* acidification factors is similar to the application of EDIP97 factors, which are also site-generic.

The site-generic as well as the site-dependent EDIP2003 acidification potentials of an emission are expressed as the area of ecosystem which is brought to exceed the critical load of acidification as a consequence of the emission (area of unprotected ecosystem = m² UES).

In comparison, the EDIP97 acidification potential is expressed as the emission of SO₂ that would lead to the same potential release of protons in the environment (g SO₂-Eq.) similar to the CML methodology. [HAUSCHILD 2003]

EcoIndicator99

For acidification, eutrophication and land-use the impacts are calculated using the Potentially Disappeared Fraction (PDF) of species. The PDF is used to express the effects on vascular plant populations in an area. The PDF can be interpreted as the fraction of species that has a high probability of no occurrence in a region due to unfavourable conditions. The fate and damage of emitted substances are calculated via computer models of the Netherlands.

Impact 2002+

The characterization factors for aquatic acidification are expressed in SO₂-equivalents and are adapted from the EDIP1997 methodology which also corresponds to the approach from CML. [IMPACT 2002]

7.5 Eutrophication Potential (EP)

Eutrophication is the enrichment of nutrients in a certain place. Eutrophication can be aquatic or terrestrial. Air pollutants, wastewater and fertilisation in agriculture all contribute to eutrophication as indicated in Figure A-4.

The result in water is an accelerated algae growth, which in turn, prevents sunlight from reaching the lower depths. This leads to a decrease in photosynthesis and less oxygen production. Oxygen is also needed for the decomposition of dead algae. Both effects cause a decreased oxygen concentration in the water, which can eventually lead to fish dying and to anaerobic decomposition (decomposition without the presence of oxygen). Hydrogen sulphide and methane are produced. This can lead to the destruction of the eco-system, among other consequences.

On eutrophicated soils, an increased susceptibility of plants to diseases and pests is often observed, as is degradation of plant stability. If the nitrification level exceeds the amounts of nitrogen necessary for a maximum harvest, it can lead to an enrichment of nitrate. This can cause, by means of leaching, increased nitrate content in groundwater. Nitrate also ends up in drinking water.

CML

Nitrate at low levels is harmless from a toxicological point of view. Nitrite, however, is a reaction product of nitrate and toxic to humans. The eutrophication potential is calculated in phosphate eq. (PO₄-Eq.). As with acidification potential, it is important to remember that the effects of eutrophication potential differ regionally.

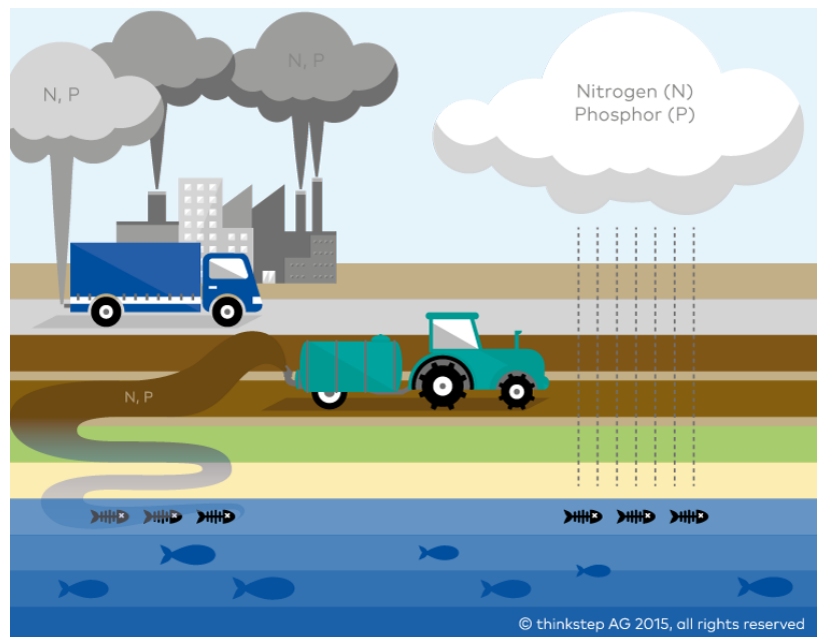

Figure A-4: Eutrophication Potential

All emissions of N and P to air, water and soil and of organic matter to water are aggregated into a single measure, as this allows both terrestrial and aquatic eutrophication to be assessed. The characterization factors in PO₄-equivalents, NO₃-equivalents and O₂-equivalents are all interchangeable, and PO₄-equivalents are used. [GUINÉE ET AL. 2001]

EF (Environmental Footprint)

The EF setup uses Accumulated Exceedance (AE) for terrestrial eutrophication and fraction of nutrients reaching freshwater end compartment (P) for freshwater eutrophication and fraction of nutrients reaching freshwater end compartment (N) for marine eutrophication.

AE uses atmospheric models to calculate the deposition of released eutrophying substance per release country and relates this value to the capacity of the receiving soil to neutralize the effects. The method integrates both the exceeded area and amount of exceedance per kg of released substance [SEPPALA 2006 and POSCH 2008].

The EF setup uses the EUTREND model as implemented in ReCiPe – with the fraction of nutrients reaching freshwater end compartment (P) and the fraction of nutrients reaching marine end compartment (N).

As spatialization is not integrated in GaBi other than for water use and land use, the method is only implemented with the generic factors provided in ILCD [ILCD 2011], EF 2.0 and EF 3.0 [PEF GUIDE 2013 and PEF METHOD 2019].

ReCiPe

ReCiPe operates with both mid-point and end-point indicators.

Mid-point indicators are divided into freshwater and marine eutrophication (marine was left out in ReCiPe 2016 v.1.0 but re-introduced in v.1.1). At the freshwater level, only phosphorous is included and at the marine level, only nitrogen is included.

As an endpoint, ReCiPe operates with species loss in freshwater on a European scale. [RECIPE 2012; RECIPE 2016].

TRACI 2.1

The characterization factors of TRACI 2.1 estimate the eutrophication potential of a release of chemical containing N or P to air or water relative to 1 kg N discharged directly to surface freshwater, therefore with the unit kg N eq. [TRACI 2012]

UBP 2013, Ecological Scarcity Method

The “ecological scarcity” method permits impact assessment of life cycle inventories according to the “distance to target” principle.

Eco-factors, expressed as eco-points per unit of pollutant emission or resource extraction, are normalised and weighted according to Swiss national policy targets, as well as international targets supported by Switzerland. For acidification, this is a 50% reduction target in Rhine catchment according to the OSPAR Commission. [UBP 2013]

EPS 2015d(x)

The EPS method calculates Environmental Load Units equal to one Euro of environmental damage cost per kg emission of substance as a combined cost of different environmental effects [EPS 2015].

EDIP 2003

The EDIP 2003 methodology distinguishes between aquatic and terrestrial eutrophication.

Aquatic eutrophication

The aquatic inputs are atmospheric deposition of nitrogen on soil and coastal seas, phosphorus and nitrogen supply to agricultural soils, phosphorus and nitrogen discharged with municipal wastewater. A computer model (CARMEN) calculates transport of the inlet nutrients to surface water.

The nitrogen and phosphorus sources have been allocated to each grid-element on the basis of the distribution of land uses in the given grid-element (arable land, grassland, permanent crops, forest, urban area, inland waters).

The transport of nutrient by rivers to sea is modelled assuming fixed removal rates of N and P in freshwater systems. [HAUSCHILD 2003]

Terrestrial eutrophication

Site-dependent factors have been established for 44 European countries or regions. The eutrophication factors relate an emission by its region of release to the acidifying impact on its deposition areas.

The site-generic terrestrial eutrophication factors are established as the European average over the 15 EU member countries in the EU15 plus Switzerland and Norway, weighted by the national emissions. The site-generic as well as the site-dependent EDIP2003 acidification potentials of an emission are expressed as the area of ecosystem whose inclusion exceeds the critical load of eutrophication as a consequence of the emission (area of unprotected ecosystem = m² UES). [HAUSCHILD 2003]

EcoIndicator99

For acidification, eutrophication and land-use the impacts are calculated using the Potentially Disappeared Fraction (PDF) of species. The PDF is used to express the effects on vascular plant populations in an area. The PDF can be interpreted as the fraction of species that has a high probability of no occurrence in a region due to unfavourable conditions. The fate and damage of emitted substances are calculated via computer models of the Netherlands. [ECO-INDICATOR 99 2000]

Impact 2002+

Midpoint characterization factors (in kg PO₄³⁻-equivalents) are given for emissions into air, water and soil with characterization factors taken directly from CML. No aquatic eutrophication damage factors (in PDF·m²·yr/kg emission) are given because no available studies support the assessment of damage factors for aquatic eutrophication. [IMPACT 2002]

7.6 Photochemical Ozone Creation Potential (POCP)

Despite playing a protective role in the stratosphere, ozone at ground level is classified as a damaging trace gas. Photochemical ozone production in the troposphere, also known as summer smog, is suspected to damage vegetation and material. High concentrations of ozone are toxic to humans.

Radiation from the sun and the presence of nitrogen oxides and hydrocarbons incur complex chemical reactions, producing aggressive reaction products, one of which is ozone. Nitrogen oxides alone do not cause high ozone concentration levels.

Hydrocarbon emissions occur from incomplete combustion, in conjunction with petrol (storage, turnover, refuelling) or from solvents (Figure A-5). High concentrations of ozone arise when temperature is high, humidity is low, air is relatively static and there are high concentrations of hydrocarbons. Today it is assumed that the existence of NO and CO reduces the accumulated ozone to NO₂, CO₂ and O₂. This means that high concentrations of ozone do not often occur near hydrocarbon emission sources. Higher ozone concentrations more commonly arise in areas of clean air, such as forests, where there is less NO and CO.

CML

In Life Cycle Assessments photochemical ozone creation potential (POCP) is often referred to in ethylene-equivalents (C₂H₄-Eq.). During analysis, it is important to note that the actual ozone concentration is strongly influenced by the weather and by the characteristics of local conditions.



Figure A-5: Photochemical Ozone Creation Potential

The most recent POCP factors are still the ones used for the original CML methodology with only a few adjustments. [GUINÉE ET AL. 2001]

EF (Environmental Footprint)

POCP is based on the ReCiPe 1.08 source in NMVOC equivalents. The dynamic model LOTOS-EUROS was applied to calculate intake fractions for ozone due to emissions of NO_x.

The mid-point characterization

factor for ozone formation of a substance is defined as the marginal change in the 24h-average European concentration of ozone (in kg/m³) due to a marginal change in emission (in kg/year). It is expressed as NO_x equivalents.

ReCiPe

The dynamic model LOTOS-EUROS was applied to calculate intake fractions for ozone due to emissions of NO_x.

The mid-point characterization factor for ozone formation of a substance is defined as the marginal change in the 24h-average European concentration of ozone (in kg/m³) due to a marginal change in emission (in kg/year). It is expressed as NMVOC-equivalents for ReCiPe 1.08 and changed to NO_x equivalents in ReCiPe 2016.

For ReCiPe 1.08 the end-point indicator is human health expressed as DALYs [RECIPE 2012]. ReCiPe 2016 operates with two endpoints for POCP; damage to human health (in DALYs) and damage to terrestrial ecosystems (in species*years) [RECIPE 2016].

TRACI 2.1

Impacts of photochemical ozone creation are quantified using the Maximum Incremental Reactivity (MIR) scale. This scale is based on model calculations of effects of additions of the VOCs on ozone formation in one-day box model scenarios representing conditions where ambient ozone is most sensitive to changes in VOC emissions. The emissions are normalised relative to ozone (O₃-equivalents). [TRACI 2012]

UBP 2013, Ecological Scarcity Method

Eco-factors, expressed as eco-points per unit of pollutant emission, are normalised against the entirety of Switzerland and weighted according to Swiss national policy targets. For POCP the target value is the average of three values [UBP 2013]:

Swiss Federal Air Pollution Control Ordinance's ambient limit values for ozone

The Swiss air pollution control strategy stipulates a reduction to the level of 1960 as a minimum target for NMVOCs

The environment ministers of Germany, Liechtenstein, Switzerland and Austria adopted a declaration setting the target of reducing NMVOC emissions by 70-80% from the level of the 1980s.

EPS 2015d(x)

The EPS method calculates Environmental Load Units equal to one Euro of environmental damage cost per kg of emission. The substances are often calculated for having multiple effects, e.g., VOCs contributing to both climate change and POCP [EPS 2015].

EDIP 2003

The EDIP2003 characterization factors for photochemical ozone formation have been developed using the RAINS model, which was also used for development of characterization factors for acidification and terrestrial eutrophication. Site-generic factors have been established, in addition to site-dependent factors for 41 European countries or regions. The photochemical ozone formation factors relate an emission by its region of release to the ozone exposure and impact on vegetation or human beings within its deposition areas. [HAUSCHILD 2003]

EcoIndicator99

In EcoIndicator99, the POCP expresses the incremental ozone concentration per incremental emission for specific VOC species normalised by the ratio for ethylene, equivalent to the CML approach. This is then calculated further via epidemiological studies to yield the end-point indicator of Disability Adjusted Life Years (DALYs). [ECO-INDICATOR 99 2000]

Impact 2002+

Photochemical oxidation (damage in DALY/kg emissions) is taken directly from Eco-indicator 99. Midpoints are given relative to air emissions of ethylene equivalent to CML. [IMPACT 2002]

7.7 Ozone Depletion Potential (ODP)

Ozone is created in the stratosphere by the disassociation of oxygen atoms that are exposed to short-wave UV-light. This leads to the formation of the so-called ozone layer in the stratosphere (15-50 km high). About 10% of this ozone reaches the troposphere through mixing processes. In spite of its minimal concentration, the ozone layer is essential for life on earth. Ozone absorbs

the short-wave UV-radiation and releases it in longer wavelengths. As a result, only a small part of the UV-radiation reaches the earth.

Anthropogenic emissions deplete ozone. This is well-known from reports on the hole in the ozone layer. The hole is currently confined to the region above Antarctica; however further ozone depletion can be identified, albeit not to the same extent, over the mid-latitudes (e.g., Europe). The substances that have a depleting effect on the ozone can essentially be divided into two groups; the chlorofluorocarbons (CFCs) and the nitrogen oxides (NO_x). Figure A-6 depicts the procedure of ozone depletion.

One effect of ozone depletion is the warming of the earth's surface. The sensitivity of humans, animals and plants to UV-B and UV-A radiation is of particular importance. Possible effects are changes in growth or a decrease in harvest crops (disruption of photosynthesis), indications of tumours (skin cancer and eye diseases) and a decrease of sea plankton, which would strongly affect the food chain. In calculating the ozone depletion potential, the anthropogenically released halogenated hydrocarbons, which can destroy many ozone molecules, are recorded first. The Ozone Depletion Potential (ODP) results from the calculation of the potential of different ozone relevant substances.

A scenario for a fixed quantity of emissions of a CFC reference (CFC 11) is calculated, resulting in an equilibrium state of total ozone reduction. The same scenario is considered for each substance under study where CFC 11 is replaced by the quantity of the substance. This leads to the ozone depletion potential for each respective substance, which is given in CFC 11-equivalents. An evaluation of the ozone depletion potential should take into consideration the long term, global and partly irreversible effects.

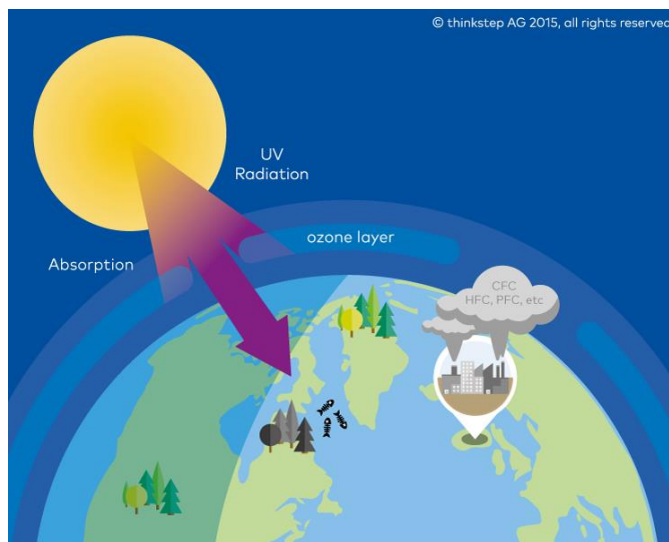

Figure A-6: Ozone Depletion Potential

CML

In CML, the ODPs published by the World Meteorological Organisation (WMO) from 2002 are used. [GUINÉE ET AL. 2001]

ReCiPe

The ODPs from Ecoindicator are used as equivalency factors, characterising substances at the midpoint level. As an end-point indicator, only damage to human health (skin cancer and cataracts) is addressed because uncertainty regarding other areas of protection was considered too large. In a new approach, the fate of a marginal increase of emission of ozone depleting substances and the resulting worldwide increase of UVB exposure is evaluated, taking into account population density, latitude and altitude. For characterization of damage, protective factors are accounted for, such as skin colour and culturally determined habits such as clothing. [RECIPE 2012]

TRACI 2.1

Within TRACI 2.1, the most recent sources of ODPs from WMO (World Meteorological Organization) are used for each substance. [TRACI 2012]

UBP 2013, Ecological Scarcity Method

The Swiss Chemicals Risk Reduction Ordinance prohibits the production, importation and use of ozone- depleting substances. Exemptions regarding importation and use are presently only in place for the maintenance of existing HCFC refrigeration equipment and for the recycling of HCFC refrigerants with a transitional period lasting until 2015.

The primary stocks formed in building insulation materials will continue releasing considerable amounts. No critical flow can therefore be derived directly from the wide-ranging ban on the consumption of ozone-depleting substances.

The tolerated emissions are taken as the basis for determining the critical flow. As the exemptions for HCFC use in existing refrigeration equipment terminate in 2015, the anticipated emissions in 2015 are used as the critical flow (the target). The current emissions are estimated to calculate the ecofactor.

Standard ODPs are used to convert this ecofactor to other ozone-depleting substances. [UBP 2013]

EF (Environmental Footprint)

The EF 3.0 setup uses the updated WMO factors of 2014 [WMO 2014].

EPS 2015d(x)

The EPS method calculates Environmental Load Units equal to one Euro of environmental damage cost per kg emission. For several of the halogenated substances there is a contribution to both ozone depletion and climate change and the cost represent the combined damage cost [EPS 2015].

EDIP 2003

The EDIP factors are calculated via the same principle as CML. [HAUSCHILD 2003]

EcoIndicator99

The fate of CFC11 was modelled and used to estimate the fate of other substances. Standard ODPs are used to relate this to reduction in ozone. The increase in UV radiation was then used to estimate the increase in eye cataract and skin cancer which is finally expressed as Disability Adjusted Life Years (DALYs). [ECO-INDICATOR 99 2000]

Impact 2002+

Midpoints (kg CFC-11-Eq. into air/kg emission) have been obtained from the US Environmental Protection Agency Ozone Depletion Potential List. The damage factor (in DALY/kg emission) for the midpoint reference substance (CFC-11) was taken directly from Eco-indicator 99. Damage (in DALY/kg emission) for other substances has been obtained by the multiplication of the midpoints (in kg CFC-11- Eq. into air/kg emission) and the CFC-11 damage factor (in DALY/kg CFC-11 emission). [IMPACT 2002]

7.8 Human and eco-toxicity

USETox

USETox is a scientific consensus model developed by those behind the CalTOX, IMPACT 2002, USES-LCA, BETR, EDIP, WATSON and EcoSense.

In 2005, a comprehensive comparison of life cycle impact assessment toxicity characterization models was initiated by the United Nations Environment Program (UNEP)–Society for Environmental Toxicology and Chemistry (SETAC) Life Cycle Initiative, directly involving the model developers of CalTOX, IMPACT 2002, USES-LCA, BETR, EDIP, WATSON and EcoSense.

The main objectives of this effort were (1) to identify specific sources of differences between the models' results and structure, (2) to detect the indispensable model components and (3) to build a scientific consensus model from them, which represent the recommended practise.

Based on a referenced database, it has now been used to calculate CFs for several thousand substances and forms the basis of the recommendations from UNEP-SETAC's Life Cycle Initiative regarding characterization of toxic impacts in life cycle assessment.

The model provides both recommended and indicative (to be used with more caution) characterization factors for human health and freshwater ecotoxicity impacts.

GaBi has a set of standard flows established through the LCA projects and models developed over the years. This flow list is expanded to include all the recommended characterization factors from USETox, supplemented with a few factors from the indicative group to allow for a consistent coverage of the GaBi standard flows. USETox is implemented in two versions – one including only the 'Recommended' factors and one with both the 'Recommended' and 'Interim' substances.

GaBi contains only one air compartment which is calculated as the average of the urban air and continental rural air from USEtox. The emission compartments of 'household indoor air' and 'industrial indoor air' are not implemented in GaBi.

The standard emission compartments in GaBi includes emission to industrial soil – an emission compartment not available in USEtox. This is modelled using the characterization factors for agricultural soil.

The USEtox characterization of direct application to wheat as crop is not implemented.

USEtox also contains end-point characterization factors that are not implemented in GaBi.

Finally, it is worth noticing that USEtox considers ecotoxicity towards freshwater organisms and also, when the direct emission compartment is air, soil or marine water. Terrestrial or marine organisms are currently not included.

USEtox calculates characterization factors for human toxicity and freshwater ecotoxicity via three steps: environmental fate, exposure and effects.

The continental scale of the model consists of six compartments: urban air, rural air, agricultural soil, industrial soil, freshwater and coastal marine water. The global scale has the same structure, but without the urban air.

The human exposure model quantifies the increase in amount of a compound transferred into the human population based on the concentration increase in the different media.



Figure A-7: Toxicity Potential

Human effect factors relate the quantity taken in to the potential risk of adverse effects in humans. It is based on cancerous and non-cancerous effects derived from laboratory studies.

Effect factors for freshwater ecosystems are based on species-specific data of concentration at which 50% of a population displays an effect.

The final characterization factor for human toxicity and aquatic ecotoxicity is calculated by summation of the continental- and the global-scale assessments.

The characterization factor for human toxicity is expressed in comparative toxic units (CTUh), providing the estimated increase in morbidity per unit mass of a chemical emitted (cases per kilogram).

The characterization factor for aquatic ecotoxicity is expressed in comparative toxic units (CTUe) and provides an estimate of the potentially affected fraction of species (PAF) integrated over time and volume per unit mass of a chemical emitted (PAF m³-day/ kg). [USETox 2010]

ReCiPe

The characterization factor of human toxicity and ecotoxicity is composed of the environmental persistence (fate) and accumulation in the human food chain (exposure), and toxicity (effect) of a chemical. The ReCiPe method uses an update of the model used in the CML methodology referred to as USES-LCA; used as v2.0 in ReCiPe 1.08 and v.3.0 in ReCiPe 2016 v1.1.

The recent version ReCiPe 2016 switched to using the USEtox database on the characteristics of the evaluated substances, but still performing the actual modelling the USES-LCA model.

The two potential human toxicity impacts (cancer and non-cancer) and three categories of ecotoxicity (freshwater, marine and terrestrial) are expressed as mid-point indicators relative to 1,4-Dichlorobenzol (kg DCB-Eq.).

The end-point indicators are expressed in DALYs for human toxicity and species loss for ecotoxicity. [RECIPE 2012; RECIPE 2016]

TRACI 2.1

The TRACI 2.1 methodology has incorporated the USEtox model to account for toxicity. [TRACI 2012]

EF (Environmental Footprint)

For EF 3.0, all characterization factors have been recalculated using REACH-related substance properties and the latest USEtox model. Safety factors for inorganic, metals, essential elements have been applied.

UBP 2013, Ecological Scarcity Method

The method has developed ecopoints per kg-emitted substance for only a limited amount of substances [UBP 2013]. The characterization factors are based on the USEtox model.

CML

The CML toxicity calculations are based on fate modelling with USES-LCA. This multimedia fate is divided into 3% surface water, 60% natural soil, 27% agricultural soil and 10% industrial soil. 25% of the rainwater is infiltrated into the soil.

The potential toxicities (human, aquatic and terrestrial ecosystems) are generated from a proportion based on the reference substance 1,4-Dichlorobenzol ($C_6H_4Cl_2$) in the air reference section. The unit is kg 1,4-Dichlorobenzol-Equiv. (kg DCB-Eq.) per kg emission [GUINÉE ET AL. 2002].

The identification of the toxicity potential is rife with uncertainties because the impacts of the individual substances are extremely dependent on exposure times and various potential effects are aggregated. The model is therefore based on a comparison of effects and exposure assessment. It calculates the concentration in the environment via the amount of emissions, a distribution model and the risk characterization via an input-sensitive module. Degradation and transport in other environmental compartments are not represented. [GUINÉE ET AL. 2001]

EPS 2015d(x)

The EPS method calculates Environmental Load Units equal to one Euro of environmental damage cost per kg substance emission. When a substance is contributing to more than one impact the factor is the combined cost [EPS 2015].

EDIP 2003

Toxicity impacts from EDIP 2003 are no longer included in GaBi, as the EDIP methodology has shifted to using the USETox methodology to assess toxicity impacts.

EcolIndicator99

For the fate analysis of carcinogenic substances causing damage to Human Health and ecotoxic substances causing damage to Ecosystem Quality, the European Uniform System for the Evaluation of Substances (EUSES) is used. Different environmental media (air, water, sediment, and soil) are modelled as homogeneous, well-mixed compartments or boxes.

Substances that cause respiratory effects are modelled with atmospheric deposition models and empirical observations.

The damage, expressed as the number of Disability-Adjusted Life Years (DALYs), measures the total amount of ill health, due to disability and premature death, attributable to specific diseases and injuries. [ECO-INDICATOR 99 2000]

Impact 2002+

Impact 2002+ expresses toxicity in a total of four mid-point impact categories; human toxicity (carcinogen and non-carcinogen effects), respiratory effects (caused by inorganics), aquatic ecotoxicity, and terrestrial ecotoxicity.

Damages are expressed in Disability-Adjusted Life Years for human effects and Potentially Disappeared Fraction (PDF) of species for ecotoxic effects. [IMPACT 2002]

7.9 Resource depletion

The abiotic depletion potential (ADP) covers some selected natural resources as metal-containing ores, crude oil and mineral raw materials. Abiotic resources include raw materials from non-living resources that are non-renewable. This impact category describes the reduction of the global amount of non-renewable raw materials. Non-renewable means a time frame of at least 500 years. The abiotic depletion potential is typically split into two sub-categories, elements and fossil (i.e., energy).



© thinkstep AG 2015, all rights reserved

Figure A-8: Resource depletion

Abiotic depletion potential (elements) covers an evaluation of the availability of natural elements like minerals and ores, including uranium ore. The reference substance for the characterization factors is typically antimony. Ongoing method developments look into dissipative approaches to resources, given the inherent method weakness of scarcity approaches, but also data uncertainties and open questions on the area of protection remain unresolved, without wide agreement.

CML

Three calculations of ADP (elements) from CML are integrated in GaBi:

- The baseline version based on ultimate reserve (i.e., the total mineral content in the earth crust)
- The reserve base which includes what is considered available in significant concentrations in the earth,
- The economic reserve based on what is evaluated as being economically feasible to extract.

GaBi contains resources that are not directly elemental. Examples are:

- mineral ore e.g., 8% zinc ore

- combined ores e.g., Zinc - Copper - Lead - Ore (4% Zn 0.09% Cu 0.65% Pb)
- minerals e.g., bauxite (Al₂O₃) for aluminium mining

Sphera has performed a stoichiometric calculation of the resource depletion of these types of resources.

The second sub-category is abiotic depletion potential (fossil), which includes the fossil energy carriers (crude oil, natural gas, coal resources). The actual list of characterization factors from CML contains only one example of each energy carrier with a specific calorific value but with a characterization factor equal to the lower calorific value. This principle is used to characterize all the GaBi fuels with MJ of lower calorific value. Uranium is accounted for in ADP (elements) and is not listed as a fossil fuel. [GUINÉE ET AL. 2001].

EF (Environmental Footprint)

The EF setup uses the same principle as CML, with the ultimate reserve chosen as variant. In the first implementation this included the stoichiometric calculation of additional resources as described above – a calculation that was removed in GaBi Databases for the version EF 2.0 to stay EF conformant, while this means to disregard some relevant resource elementary flows.

For the version EF 3.0, the above mentioned stoichiometric calculation of additional resources is implemented in GaBi again, while being EF conformant. When exporting a process dataset to ILCD format (and hence mapped at export to the EF 3.0 elementary flow list), flows with mixed ore content are split and mapped to the individual ore flows. In order to get consistent result calculations on an exported process dataset and on the same process within GaBi, flows with mixed ore content are now characterized in GaBi according to their ore content.

We anticipate that dissipative approaches may replace the scarcity approach.

ReCiPe

The marginal cost increase on the deposit level can be defined as the marginal average cost increase (\$/\$) due to extracting a dollar value of deposit (1/\$).

From the marginal cost increase factor on the deposit level, the cost increase factor on commercial metal level is calculated. The mid-point is then related to iron as iron equivalents (Fe-Eq.). The endpoint indicator is the economic value in \$. [RECIPE 2012]

Anthropogenic Abiotic Depletion Potential (AADP)

Conventional ADP indicators excluded materials stored in the technosphere, the anthropogenic stock. Total anthropogenic stock is determined as the accumulated extraction rate since the beginning of records in ~1900 until 2008 based on data from the U.S. Geological Survey. It is

assumed that the amount of materials mined before is negligible. This is split between employed and deposited stock.

Employed stock is the resource that is still in circulation. It is composed of resources in use and resources hibernating, which is resources in storage before eventually being discarded.

Expended stock is the total amount of resource that has been discarded. It is made up of deposited and dissipated stock. The deposited stock, e.g., in landfills, enables future recovery whereas the dissipated stock is emitted to the environment in a form that makes recovery almost impossible e.g., water emissions of metals.

The implemented AADP is the total anthropogenic stock (excluding the dissipated stock) added to the conventional ADP factors. It is indicated relative to antimony as has the unit kg Sb-eq. [SCHNEIDER 2011]

TRACI 2.1

The abiotic resource depletion in TRACI 2.1 focuses on fossil fuels with an approach taken from Ecoindicator. Extraction and production of fossil fuels consume the most economically recoverable reserves first, making continued extraction more energy intensive, hence the unit of MJ surplus energy. [TRACI 2012]

UBP 2013, Ecological Scarcity Method

Eco-factors, expressed as eco-points per MJ of energy consumption are used for energy. Minerals are not included. [UBP 2013]

EPS 2015d(x)

The EPS method calculates Environmental Load Units equal to one Euro of environmental damage cost per MJ of energy and per kg of mineral element/resource consumption [EPS 2015].

EDIP 2003

The former EDIP methodology, EDIP 1997, contained a resource category consisting of 87 resource quantities (minerals and fossil resources) without any classification or characterization. This category is omitted in the EDIP 2003 update. [HAUSCHILD 2003]

EcoIndicator99

The primary assumption in this method is that if the resource quality is reduced, the effort to extract the remaining resource increases. Plain market forces will ensure that mankind always exploits the resources with the highest quality. This means each time a kg of a resource is used, the quality of the remaining resources is slightly decreased and thus the effort to extract the remaining resources is increased. The damage to resources is measured in MJ of surplus energy,

which is defined as the difference between the energy needed to extract a resource now and at some specific point in the future. [ECO-INDICATOR 99 2000]

Impact 2002+

Characterization factors for non-renewable energy consumption, in terms of the total primary energy extracted, are calculated with the upper heating value. It is taken from ecoinvent (Frischknecht et al. 2003).

Mineral extractions in MJ surplus energy are taken directly from Eco-indicator. [IMPACT 2002]

7.10 Land Use

Land use and land conversion is considered a limited resource.



Figure A-9: Land use and conversion

LANCA®

Land is a limited resource. The LANCA method is integrated in GaBi via five indicators: Erosion resistance, mechanical filtration, physicochemical filtration, groundwater replenishment, and biotic production. The five indicators are available both as continuous land occupation and for land transformation. The land occupation and transformation is evaluated against the natural condition of the ecosystem. For European conditions, this is mostly forest.

The background is the LANCA® tool (Land Use Indicator Calculation Tool) based on country-specific input data and the respective land use types. A detailed description of the underlying methods can be found in [BOS ET AL. 2016] and [BECK, BOS, WITTSTOCK ET AL. 2010] and BOS 2019]

Land Use, Soil Organic Matter (SOM)

SOM (closely related to soil organic carbon, SOC) is basically a balance of the organic matter in soil related to the anthropogenic use of land for human activity. Initial organic content, as well as an annual balance of the organic matter in the soil, is necessary to calculate this [MILA I

CANALS 2007]. It is currently integrated via a set of generic factors for land occupation and transformation calculated by ILCD [ILCD 2011]. On a site-specific level, it can be calculated from LCI datasets as net CO₂ extracted from atmosphere minus carbon flows to water, and carbon uptake in products.

EF (Environmental Footprint)

The EF setup uses an aggregation, performed by the European Commission's JRC, of four indicators out of five provided by the LANCA methodology (Biotic production, Erosion resistance, Mechanical filtration, Groundwater regeneration) model as indicator for land use. The single indicators are rescaled, in order to have them without a unit, and afterwards weighted with the factors 1-1-1-1. In EF 2.0, the LANCA characterization factors V2.3 were used having only one reference situation per country. In EF 3.0, the LANCA characterization factors V2.5 were used using different reference situations and an improved rescaling of the single indicators.

EPS 2015d(x)

The EPS method calculates Environmental Load Units equal to one Euro of environmental damage cost per land use type based on loss of capacity for e.g., drinking water generation, loss of crop and wood production, and productivity loss due the increased heat in urban areas.

Land transformation is not included in EPS 2015, all impacts are allocated to the subsequent use of transformed land [EPS 2015].

7.11 Water use

In August 2014, a new standard under the 14000 series (environmental management) has been released by the ISO: ISO 14046 on Water Footprint [ISO 14046]. The standard specifies principles, requirements and guidelines related to water footprint assessment of products, processes and organizations based on life cycle assessment. A water footprint assessment conducted according to this international standard:

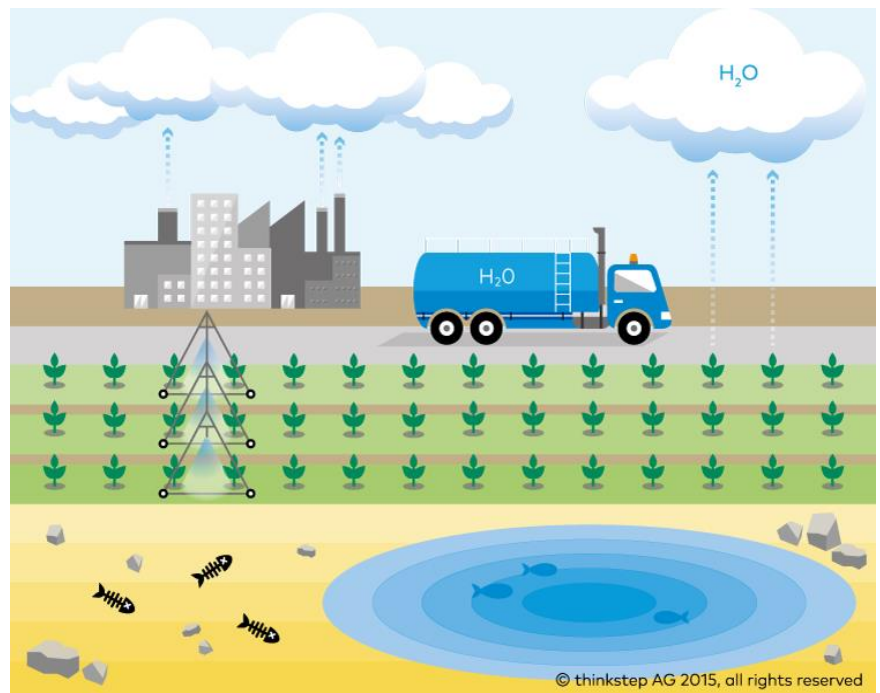

Figure A-10: Water depletion

- is based on a life cycle assessment (according to ISO 14044);
- is modular (i.e., the water footprint of different life cycle stages can be summed to represent the water footprint);
- identifies potential environmental impacts related to water;
- includes relevant geographical and temporal dimensions;
- identifies quantity of water use and changes in water quality;
- utilizes hydrological knowledge.

With this standard, regional impact assessment is officially introduced into the LCA world.

GaBi Freshwater Quantities

All water-related flows of GaBi LCI data are updated to enable consistent, high quality water modelling for water use assessments and water footprinting according to the upcoming ISO Water Footprint standard, the Water Footprint Network Manual and other emerging guidelines.

Four new water quantities were implemented to reflect the latest status of best practise in water footprinting and water assessments.

- Total freshwater consumption (including rainwater)
- Blue water consumption
- Blue water use
- Total freshwater use

Furthermore, we added a “Total freshwater consumption (including rainwater)” quantity in the light of the recommended ILCD methods carrying a characterised value according to the UBP method.

AWARE

AWARE is to be used as a water-use midpoint indicator representing the relative Available Water Remaining per area in a watershed, after the demand of humans and aquatic ecosystems has been met. It assesses the potential of water deprivation, to either humans or ecosystems, building on the assumption that the less water remaining available per area, the more likely another user will be deprived.

It is first calculated as the water Availability Minus the Demand (AMD) of humans and aquatic ecosystems and is relative to the area ($m^3 m^{-2} month^{-1}$). In a second step, the value is normalized with the world average result ($AMD = 0.0136 m^3 m^{-2} month^{-1}$) and inverted, and

hence represents the relative value in comparison with the average m³ consumed in the world (the world average is calculated as a consumption-weighted average). Once inverted, 1/AMD can be interpreted as a surface-time equivalent to generate unused water in this region. The indicator is limited to a range from 0.1 to 100, with a value of 1 corresponding to the world average, and a value of 10, for example, representing a region where there is 10 times less available water remaining per area than the world average. [AWARE]

Water Scarcity Index (WSI)

WSI operates with potential environmental damages of water use for three areas: human health, ecosystem quality, and resources. Focus is placed on the effects of consumptive water use as a function of total water availability.

The commonly used water to availability ratio (WTA) is initially calculated for each watershed, which is the fraction of available water (WA) used (WU) by each sector (WTA=WU/WA)

A weighting factor is applied to the WTA calculated for each watershed to account for variations in monthly or annual flows. The weighted WTA is then expressed as WTA* and the WSI is calculated as follows:

$$WSI = \frac{1}{1 + e^{-6.4WTA^* \left(\frac{1}{0.01} - 1 \right)}}$$

The WSI expresses the minimal water stress as 0.01. The distribution curve is adjusted so a WSI value greater than 0.5 is representative as a severely stressed area. [PFISTER ET AL. 2009]

WAVE+

The WAVE+ (Water Accounting and Vulnerability Evaluation) model is used for assessing local impacts of water use. The WAVE+ quantities can be used to assess impact of water consumption, and focus on blue water consumption only.

The method considers the basin internal evaporation recycling (BIER), i.e., the fraction of evaporation returning to the originating basin as rain. Potential local impacts of water consumption are quantified by means of the water deprivation index (WDI), which denotes the risk to deprive other users from using freshwater when consuming water [m³deprived/m³consumed]. In order to support applicability in water footprinting and life cycle assessment, BIER and WDI are combined to an integrated WAVE+ factor, which is provided on different temporal and spatial resolutions. In GaBi the aggregated annual country averages are implemented. For the assessment, the country specific water flows are multiplied with the corresponding characterization factors [BERGER ET AL. 2018].

EF (Environmental Footprint)

The EF setup uses the AWARE methodology as a measure for water scarcity.

EPS 2015d(x)

The EPS method only finds an environmental damage load when using fossil ground water. Other freshwater resources are not evaluated [EPS 2015].

7.12 Particulate matter formation (PM)

Riskpoll

The Riskpoll model evaluates human health impacts from primary particles emitted directly and from secondary particles formed in the air by emitted substances [RABL AND SPADARO 2004]. The reference unit is kg PM_{2.5} eq.

ReCiPe 1.08

The atmospheric fate was calculated using a combination of the models EUTREND and LOTOS-EUROS including effects of both primary and secondary particles. The reference unit is kg PM₁₀ eq.

TRACI 2.1

These intake fractions are calculated as a function of the amount of substance emitted into the environment, the resulting increase in air concentration, and the breathing rate of the exposed population. The increasing air concentrations are a function of the location of the release and the accompanying meteorology and the background concentrations of substances, which may influence secondary particle formation. Substances were characterised using PM_{2.5} as the reference substance.

EPS 2015d(x)

The EPS 2015 method calculates Environmental Load Units equal to one Euro of environmental damage cost per kg emission. The version 2015d includes the impact from secondary particle formation whereas version 2015dx excludes this impact [EPS 2015].

EF (Environmental Footprint)

The EF setup uses the unit deaths per kg of emission including the impact of secondary particle formation as a combination of the UNEP and Riskpoll model (FANTKE 2016).

7.13 Odour potential

An indicator called odour footprint considers the odour detection threshold, the diffusion rate and the kinetics of degradation of odorants [PETERS ET AL. 2014].

7.14 Normalization

Normalization relates each impact to a reference of a per capita or a total impact for a given area for a given year. An overview is given in Table P.

Table Q: Normalization references

Methodology	Impact calculated (year)	Area(s) covered
CML 2001	Total impact (2000)	World, Europe
ReCiPe 1.08, Ecoindicator	Per capita impact (2000)	World, Europe
TRACI 2.1	Per capita impact (2006)	USA, USA+Canada
EDIP 2003	Per capita impact (1994)	Europe
UBP 2013	Per capita impact (various)	Switzerland
USETox	Per capita impact (2004 Europe) (2002/2008 North America)	Europe, North America
PEF	Per Capita or global	World

Conversion between CML and ReCiPe is possible using a global population of 6,118,131,162 and a EU25+3 population of 464,621,109 in year 2000 [EUROSTAT 2012] [WORLD BANK 2012]. Notably the '+3' countries in EU25+3 are Iceland, Norway, and Switzerland.

The PEF normalization is using a global population of 6,895,889,018 in year 2010 to convert between global and person equivalents.

7.15 Weighting

The weighting attaches a value to each of the normalized values, giving a value-based importance to each impact. This can be based on political reduction targets or on the opinions of experts and/or nonprofessionals, for example.

ReCiPe

For the ReCiPe method, a weighting of the endpoint indicators is available from the authors based on one of the three cultural perspectives (E, H or I) or as an average (A). The midpoint indicators are not weighted.

Sphera (named "thinkstep")

In 2012 Sphera (at that time still PE International) sent out a questionnaire worldwide asking experts to value the main environmental impact categories on a 1-10 scale. The total number of respondents were 245 mainly consultants and academia and mainly from Europe and North America. Figure A-11 below gives an overview of the respondents with the area and color of each rectangle representing the number of people within each category.

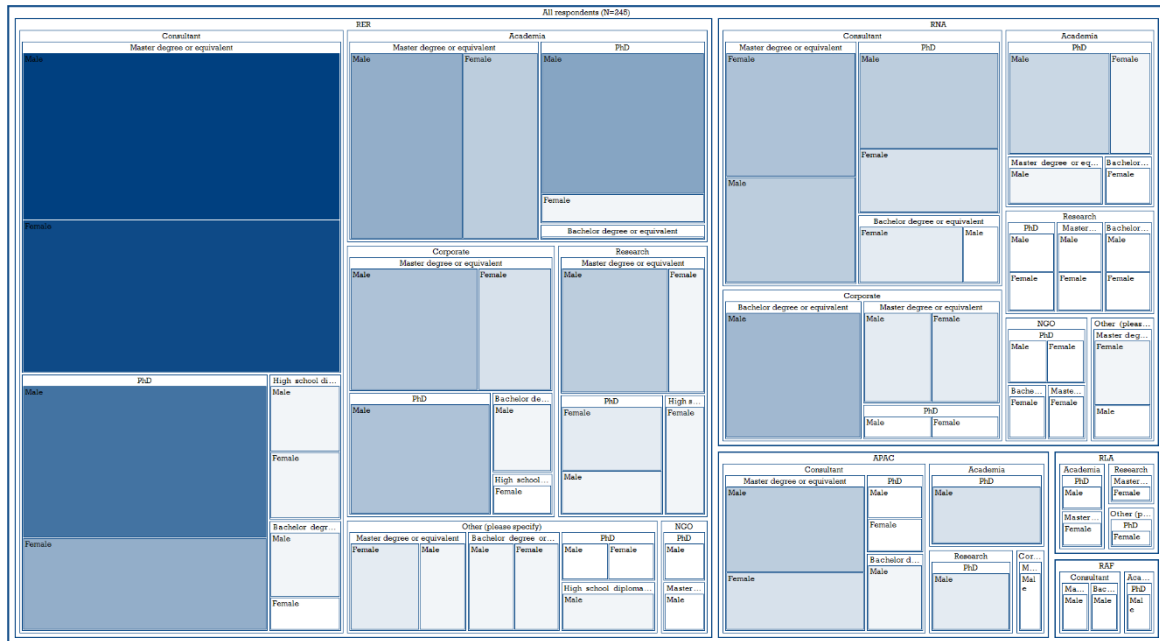

Figure A-11: Response to thinkstep Weighting 2012

The answers from the questionnaires led to the weighting factors in Table Q. The weighting factors are linked to the impact categories of CML and ReCiPe (Global + Europe), and for TRACI 2.1 (Global + North America). Additionally, the IPCC category for global warming is also included (Global + Europe + North America).

Table R: thinkstep Weighting 2012

Impact	Europe	North America	Global
Acidification	6.2	5.9	6.1
Eco-Toxicity	6.6	7.0	6.8
Eutrophication	6.6	6.6	6.6
Global Warming	9.3	9.5	9.3
Human Toxicity	6.9	7.5	7.1
Ionising Radiation	5.8	5.0	5.7
Ozone Depletion	6.2	6.1	6.2
Particulate Matter Formation	6.5	6.9	6.7
Photochemical Ozone	6.5	6.7	6.5
Resources, ADP elements	6.3	6.1	6.4
Resources, ADP fossil	6.9	6.7	7.0
Resources, Land Use	7.2	7.1	7.2
Water Footprint	7.9	8.4	8.0

EF (Environmental Footprint)

The EF setup in version 2.0 operates with two sets of weighting factors, one including the toxicity categories and one excluding the toxicity categories, as indicated in the table below.

Table S: Weighting factors including and excluding toxicity

Impact	Including toxicity	Excluding toxicity
Climate change	21.06	22.19
Ozone depletion	6.31	6.75
Human toxicity, cancer effects	2.13	-
Human toxicity, non-cancer effects	1.84	-
Particulate matter/Respiratory inorganics	8.96	9.54
Ionizing radiation, human health	5.01	5.37
Photochemical ozone formation, human health	4.78	5.1
Acidification	6.2	6.64
Eutrophication terrestrial	3.71	3.91
Eutrophication freshwater	2.8	2.95
Eutrophication marine	2.96	3.12
Ecotoxicity freshwater	1.92	-
Land use	7.94	8.42
Resource depletion: water	8.51	9.03
Resource depletion: mineral and metals	7.55	8.08
Resource depletion: fossil fuels	8.32	8.92

8 Appendix B List of active methods and impact categories

In Table T the most important impact categories available in GaBi and the corresponding latest LCIA methods are shown. Earlier versions and outdated methods available in GaBi are not listed in this table. The table contains information on the impact category, the version number, the method and the sources on which the respective classification and characterization factors are based.

Table T Impact categories and methods

Impact category	Version	Method	Classification and Characterization factor based on
CML 2001	Aug. 2016 ²⁴	Abiotic Depletion (ADP elements) ²⁵	van Oers et al. (2001)
CML 2001	Aug. 2016	Abiotic Depletion (ADP fossil)	van Oers et al. (2001)
CML 2001	Aug. 2016	Acidification Potential (AP)	Huijbregts (1999); (average Europe total, A&B)
CML 2001	Aug. 2016	Eutrophication Potential (EP)	Huijbregts (1999); (average Europe total, A&B)
CML 2001	Aug. 2016	Freshwater Aquatic Ecotoxicity Pot. (FAETP inf.)	Huijbregts (1999 & 2000)
CML 2001	Aug. 2016	Global Warming Potential (GWP 100 years) ²⁶	IPCC 2013 AR5
CML 2001	Aug. 2016	Human Toxicity Potential (HTP inf.)	Huijbregts (1999 & 2000); USEtox (Rozenbaum et al. 2008)
CML 2001	Aug. 2016	Marine Aquatic Ecotoxicity Pot. (MAETP inf.)	Huijbregts (1999 & 2000)
CML 2001	Aug. 2016	Ozone Layer Depletion Potential (ODP, steady state)	WMO (2003)
CML 2001	Aug. 2016	Photochem. Ozone Creation Potential (POCP)	Jenkin & Hayman (1999); Derwent et al. (1998) (high NOx); Andersson-Sköld et al. (1992) (low NOx)
CML 2001	Aug. 2016	Terrestrial Ecotoxicity Potential (TETP inf.)	Huijbregts (1999 & 2000)
EF	2.0	Acidification	Seppälä et al. (2006); Posch et al. (2008)
EF	2.0	Climate Change - total	IPCC 2013 AR5
EF	2.0	Climate Change, biogenic	IPCC 2013 AR5
EF	2.0	Climate Change, fossil	IPCC 2013 AR5
EF	2.0	Climate Change, land use and land use change	IPCC 2013 AR5

²⁴ All previous versions of CML2001 are stored in GaBi in the folder “previous versions of methods”

²⁵ Impact category available as “Ultimate”, “Economic Reserve” and “Reserve Base” version

²⁶ Impact category available as all combinations of “excl. biogenic carbon”, “incl. biogenic carbon”, “incl. LUC” and “incl. LUC (LUC only)”

Impact category	Version	Method	Classification and Characterization factor based on
EF	2.0	Ecotoxicity, freshwater	USEtox model (Rosenbaum et al. 2008)
EF	2.0	Eutrophication, freshwater	EUTREND model (Struijs et al, 2009b) as implemented in ReCiPe 2008
EF	2.0	Eutrophication, marine	EUTREND model (Struijs et al, 2009b) as implemented in ReCiPe 2008
EF	2.0	Eutrophication, terrestrial	Seppälä et al. (2006); Posch et al. (2008)
EF	2.0	Human toxicity, cancer	USEtox model (Rosenbaum et al. 2008)
EF	2.0	Human toxicity, non-cancer	USEtox 1.00 (Rosenbaum et al. 2008)
EF	2.0	Ionising radiation, human health	Frischknecht et al. (2000)
EF	2.0	Land Use	LANCA (as in Bos et al., 2016)
EF	2.0	Ozone depletion	WMO (2014) + integrations
EF	2.0	Particulate matter	Fantke et al. (2016) in UNEP (2016)
EF	2.0	Photochemical ozone formation, human health	LOTOS-EUROS model (Van Zelm et al, 2008) as implemented in ReCiPe 2008
EF	2.0	Resource use, fossils	van Oers et al. (2002)
EF	2.0	Resource use, mineral and metals	van Oers et al. (2002) (based on Guinée et al. 2002)
EF	2.0	Water use	Available WATER REMaining (AWARE) Boulay et al. (2016)
EF	3.0	Acidification	Seppälä et al. (2006); Posch et al. (2008)
EF	3.0	Climate Change - total	IPCC 2013 AR5
EF	3.0	Climate Change, biogenic	IPCC 2013 AR5
EF	3.0	Climate Change, fossil	IPCC 2013 AR5
EF	3.0	Climate Change, land use and land use change	IPCC 2013 AR5
EF	3.0	Ecotoxicity, freshwater - total ²⁷	USEtox 1.00 (Rosenbaum et al. 2008)
EF	3.0	Eutrophication, freshwater	EUTREND model (Struijs et al, 2009b) as implemented in ReCiPe 2008
EF	3.0	Eutrophication, marine	EUTREND model (Struijs et al, 2009b) as implemented in ReCiPe 2008
EF	3.0	Eutrophication, terrestrial	Seppälä et al. (2006); Posch et al. (2008)
EF	3.0	Human toxicity, cancer - total ²⁷	USEtox 1.00 (Rosenbaum et al. 2008)
EF	3.0	Human toxicity, non-cancer - total ²⁷	USEtox 1.00 (Rosenbaum et al. 2008)
EF	3.0	Ionising radiation, human health	Frischknecht et al. (2000)
EF	3.0	Land Use	LANCA (as in Bos et al., 2016)
EF	3.0	Ozone depletion	WMO (2014) + integrations
EF	3.0	Particulate matter	Fantke et al. (2016) in UNEP (2016)
EF	3.0	Photochemical ozone formation, human health	LOTOS-EUROS model (Van Zelm et al, 2008) as implemented in ReCiPe 2008

²⁷ Impact category available as "total" and the subcategories "Inorganic" "Metals" and "Organic"

Impact category	Version	Method	Classification and Characterization factor based on
EF	3.0	Resource use, fossils	van Oers et al. (2002)
EF	3.0	Resource use, mineral and metals	van Oers et al. (2002) (based on Guinée et al. 2002)
EF	3.0	Water use	Available WATER REmaining (AWARE) Boulay et al. (2016)
EN15804	+A1	<i>Environmental impact indicators</i>	
EN15804	+A1	Abiotic depletion potential for fossil resources (ADPF)	Oers, L.F.C.M., van & Koning, A., de & Guinée, J.B. & Huppes, G., (2002)
EN15804	+A1	Abiotic depletion potential for non fossil resources (ADPE)	Oers, L.F.C.M., van & Koning, A., de & Guinée, J.B. & Huppes, G., (2002)
EN15804	+A1	Acidification potential (AP)	Huijbregts, M. (1999b)
EN15804	+A1	Eutrophication potential (EP)	Heijungs, R., J. Guinée, G. Huppes, R.M. Lankreijer, H.A. Udo de Haes, A. Wegener Sleswijk, A.M.M. Ansems, P.G. Eggels, R. van Duin, H.P. de Goede, 1992
EN15804	+A1	Global warming potential (GWP)	IPCC 2007 AR4
EN15804	+A1	Ozone Depletion Potential (ODP)	WMO (2003)
EN15804	+A1	Photochemical Ozone Creation Potential (POCP)	Jenkin, M.E. & G.D. Hayman (1999); Derwent, R.G., M.E. Jenkin, S.M. Saunders & M.J. Pilling (1998)
EN15804	+A1	<i>Resource use indicators</i>	
EN15804	+A1	Input of secondary material (SM)	
EN15804	+A1	Non-renewable primary energy resources used as raw materials (PENRM)	
EN15804	+A1	Primary energy resources used as raw materials (PERM)	
EN15804	+A1	Total use of non-renewable primary energy resources (PENRT)	
EN15804	+A1	Total use of renewable primary energy resources (PERT)	
EN15804	+A1	Use of net freshwater (FW)	
EN15804	+A1	Use of non renewable secondary fuels (NRSF)	
EN15804	+A1	Use of non-renewable primary energy (PENRE)	
EN15804	+A1	Use of renewable primary energy (PERE)	
EN15804	+A1	Use of renewable secondary fuels (RSF)	
EN15804	+A1	<i>Output flows and waste categories</i>	
EN15804	+A1	Components for re-use (CRU)	
EN15804	+A1	Exported electrical energy (EEE)	
EN15804	+A1	Exported thermal energy (EET)	
EN15804	+A1	Hazardous waste disposed (HWD)	

Impact category	Version	Method	Classification and Characterization factor based on
EN15804	+A1	Material for Energy Recovery (MER)	
EN15804	+A1	Materials for Recycling (MFR)	
EN15804	+A1	Non-hazardous waste disposed (NHWD)	
EN15804	+A1	Radioactive waste disposed (RWD)	
EN15804	+A2	<i>Environmental impact indicators</i>	
EN15804	+A2	Acidification	Seppälä et al. (2006); Posch et al. (2008)
EN15804	+A2	Climate Change - total	IPCC 2013 AR5
EN15804	+A2	Climate Change, biogenic	IPCC 2013 AR5
EN15804	+A2	Climate Change, fossil	IPCC 2013 AR5
EN15804	+A2	Climate Change, land use and land use change	IPCC 2013 AR5
EN15804	+A2	Eutrophication, freshwater	EUTREND model (Struijs et al, 2009b) as implemented in ReCiPe 2008
EN15804	+A2	Eutrophication, marine	EUTREND model (Struijs et al, 2009b) as implemented in ReCiPe 2008
EN15804	+A2	Eutrophication, terrestrial	Seppälä et al. (2006); Posch et al. (2008)
EN15804	+A2	Ozone depletion	WMO (2014) + integrations
EN15804	+A2	Photochemical ozone formation, human health	LOTOS-EUROS model (Van Zelm et al, 2008) as implemented in ReCiPe 2008
EN15804	+A2	Resource use, fossils	van Oers et al. (2002)
EN15804	+A2	Resource use, mineral and metals	van Oers et al. (2002) (based on Guinée et al. 2002)
EN15804	+A2	Water scarcity	Available WATER REmaining (AWARE) Boulay et al. (2016)
EN15804	+A2	<i>Resource use indicators</i>	
EN15804	+A2	Input of secondary material (SM)	
EN15804	+A2	Non-renewable primary energy resources used as raw materials (PENRM)	
EN15804	+A2	Primary energy resources used as raw materials (PERM)	
EN15804	+A2	Total use of non-renewable primary energy resources (PENRT)	
EN15804	+A2	Total use of renewable primary energy resources (PERT)	
EN15804	+A2	Use of net freshwater (FW)	
EN15804	+A2	Use of non renewable secondary fuels (NRSF)	
EN15804	+A2	Use of non-renewable primary energy (PENRE)	
EN15804	+A2	Use of renewable primary energy (PERE)	
EN15804	+A2	Use of renewable secondary fuels (RSF)	
EN15804	+A2	<i>Output flows and waste categories</i>	

Impact category	Version	Method	Classification and Characterization factor based on
EN15804	+A2	Components for re-use (CRU)	
EN15804	+A2	Exported electrical energy (EEE)	
EN15804	+A2	Exported thermal energy (EET)	
EN15804	+A2	Hazardous waste disposed (HWD)	
EN15804	+A2	Material for Energy Recovery (MER)	
EN15804	+A2	Materials for Recycling (MFR)	
EN15804	+A2	Non-hazardous waste disposed (NHWD)	
EN15804	+A2	Radioactive waste disposed (RWD)	
EN15804	+A2	Biogenic carbon content	
EN15804	+A2	Biogenic carbon content in packaging	
EN15804	+A2	Biogenic carbon content in product	
EN15804	+A2	Optional indicators	
EN15804	+A2	Ecotoxicity, freshwater ²⁸	USEtox 1.00 (Rosenbaum et al. 2008)
EN15804	+A2	Human toxicity, cancer ²⁸	USEtox 1.00 (Rosenbaum et al. 2008)
EN15804	+A2	Human toxicity, non-cancer ²⁸	USEtox 1.00 (Rosenbaum et al. 2008)
EN15804	+A2	Ionising radiation, human health	Frischknecht et al. (2000)
EN15804	+A2	Land Use	LANCA (as in Bos et al., 2016)
EN15804	+A2	Particulate matter	Fantke et al. (2016) in UNEP (2016)
IPCC	AR5	GTP 20 ²⁹	IPCC 2013 AR5
IPCC	AR5	GTP 50 ²⁹	IPCC 2013 AR5
IPCC	AR5	GTP 100 ²⁹	IPCC 2013 AR5
IPCC	AR5	GWP 20 ²⁹	IPCC 2013 AR5
IPCC	AR5	GWP 50 ²⁹	IPCC 2013 AR5
IPCC	AR5	GWP 100 ²⁹	IPCC 2013 AR5
ISO 14067		GWP 100, Aviation	IPCC 2013 AR5
ISO 14067		GWP 100, Biotic	IPCC 2013 AR5
ISO 14067		GWP 100, Fossil	IPCC 2013 AR5
ISO 14067		GWP 100, Land Use	IPCC 2013 AR5
LANCA	v 2.5	Biotic Production Loss Potential (Occupation)	Baitz (2002); Bos et al. (2016); Beck, Bos, Wittstock et al. (2010); Bos (2019)
LANCA	v 2.5	Biotic Production Loss Potential (Transformation)	Baitz (2002); Bos et al. (2016); Beck, Bos, Wittstock et al. (2010); Bos (2019)
LANCA	v 2.5	Erosion Potential (Occupation)	Baitz (2002); Bos et al. (2016); Beck, Bos, Wittstock et al. (2010); Bos (2019)
LANCA	v 2.5	Erosion Potential (Transformation)	Baitz (2002); Bos et al. (2016); Beck, Bos, Wittstock et al. (2010); Bos (2019)

²⁸ Impact category available as "total" and the subcategories "Inorganic" "Metals" and "Organic"

²⁹ Impact category available as all combinations of "excl. biogenic carbon", "incl. biogenic carbon", "incl. LUC" and "incl. LUC (LUC only)"

Impact category	Version	Method	Classification and Characterization factor based on
LANCA	v 2.5	Groundwater Regeneration Reduction Potential (Occupation)	Baitz (2002); Bos et al. (2016); Beck, Bos, Wittstock et al. (2010); Bos (2019)
LANCA	v 2.5	Groundwater Regeneration Reduction Potential (Transformation)	Baitz (2002); Bos et al. (2016); Beck, Bos, Wittstock et al. (2010); Bos (2019)
LANCA	v 2.5	Infiltration Reduction Potential (Occupation)	Baitz (2002); Bos et al. (2016); Beck, Bos, Wittstock et al. (2010); Bos (2019)
LANCA	v 2.5	Infiltration Reduction Potential (Transformation)	Baitz (2002); Bos et al. (2016); Beck, Bos, Wittstock et al. (2010); Bos (2019)
LANCA	v 2.5	Physicochemical Filtration Reduction Potential (Occupation)	Baitz (2002); Bos et al. (2016); Beck, Bos, Wittstock et al. (2010); Bos (2019)
LANCA	v 2.5	Physicochemical Filtration Reduction Potential (Transformation)	Baitz (2002); Bos et al. (2016); Beck, Bos, Wittstock et al. (2010); Bos (2019)
NF EN 15804		Abiotic depletion potential (elements), complementary factors ³⁰	Developed in accordance to AFNOR XP P01-064-CN
NF EN 15804		Air pollution	Developed in accordance to AFNOR XP P01-064-CN
NF EN 15804		Water pollution	Developed in accordance to AFNOR XP P01-064-CN
ReCiPe 2016	v1.1	Climate change ^{31 32}	IPCC 2013 AR5
ReCiPe 2016	v1.1	Climate change Freshw Ecosystems ^{32, 33}	IPCC 2013 AR5
ReCiPe 2016	v1.1	Climate change Human Health ^{32, 33}	IPCC 2013 AR5
ReCiPe 2016	v1.1	Climate change Terrest Ecosystems, default, excl biogenic carbon ^{32, 33}	IPCC 2013 AR5
ReCiPe 2016	v1.1	Fine Particulate Matter Formation ³⁴	Van Zelm et al. (2016)
ReCiPe 2016	v1.1	Fossil depletion ³⁴	Vieira et al. (2012); Vieira et al. (2016)
ReCiPe 2016	v1.1	Freshwater Consumption ^{34 35}	Pfister et al. (2009); De Schryver et al. (2011); Hanafiah et al. (2011)
ReCiPe 2016	v1.1	Freshwater ecotoxicity ³⁴	Van Zelm et al. (2009, 2013)

³⁰ This impact category contains complementary characterization factors to CML 2001 Apr. 2013. The results of both impact categories have to be summed up.

³¹ ReCiPe 2016, Midpoint factors available for the Individualist (I), Hierarchist (H) and Egalitarian (E) perspectives

³² Impact category available as all combinations of “excl. biogenic carbon”, “incl. biogenic carbon”, “incl. LUC” and “incl. LUC (LUC only)”

³³ ReCiPe 2016, Endpoint factors available for the Individualist (I), Hierarchist (H) and Egalitarian (E) perspectives

³⁴ ReCiPe 2016, Midpoint and Endpoint factors available for the Individualist (I), Hierarchist (H) and Egalitarian (E) perspectives

³⁵ Impact category also available as “Freshw Ecosystems”, “Human Health” and “Terrest Ecosystems” version

Impact category	Version	Method	Classification and Characterization factor based on
ReCiPe 2016	v1.1	Freshwater Eutrophication ³⁴	Helmes et al. (2012); Azevedo et al. (2013)
ReCiPe 2016	v1.1	Human toxicity, cancer ³⁴	Van Zelm et al. (2009, 2013)
ReCiPe 2016	v1.1	Human toxicity, non-cancer ³⁴	Van Zelm et al. (2009, 2013)
ReCiPe 2016	v1.1	Ionizing Radiation ³⁴	Frischknecht et al. (2000); De Schryver et al. (2011)
ReCiPe 2016	v1.1	Land use ³⁴	De Baan et al. (2013); Elshout et al. (2014); Köllner et al. (2007); Curran et al. (2014)
ReCiPe 2016	v1.1	Marine ecotoxicity ³⁴	Van Zelm et al. (2009, 2013)
ReCiPe 2016	v1.1	Marine Eutrophication ³⁴	Not included
ReCiPe 2016	v1.1	Metal depletion ³⁴	Vieira et al. (2012); Vieira et al. (2016)
ReCiPe 2016	v1.1	Photochemical Ozone Formation, Ecosystems ³⁴	Van Zelm et al. (2016)
ReCiPe 2016	v1.1	Photochemical Ozone Formation, Human Health ³⁴	Van Zelm et al. (2016)
ReCiPe 2016	v1.1	Stratospheric Ozone Depletion ³⁴	WMO (2011)
ReCiPe 2016	v1.1	Terrestrial Acidification ³⁴	Roy et al. (2014)
ReCiPe 2016	v1.1	Terrestrial ecotoxicity ³⁴	Van Zelm et al. (2009, 2013)
TRACI	2.1	Acidification	Wenzel, H.; Hauschild, M. Z.; Alting, L. (1997)
TRACI	2.1	Ecotoxicity (recommended)	USEtox 1.00 (Rosenbaum et al. 2008)
TRACI	2.1	Eutrophication	Bare, J. C.; Norris, G. A.; Pennington, D. W.; McKone, T. (2003)
TRACI	2.1	Global Warming Air ³⁶	IPCC 2007 AR4
TRACI	2.1	Human Health Particulate Air	Humbert, S. (2009)
TRACI	2.1	Human toxicity, cancer (recommended)	USEtox 1.00 (Rosenbaum et al. 2008)
TRACI	2.1	Human toxicity, non-canc. (recommended)	USEtox 1.00 (Rosenbaum et al. 2008)
TRACI	2.1	Ozone Depletion Air	US Environmental Protection Agency (2008); WMO (1999, 2003)
TRACI	2.1	Resources, Fossil fuels	Goedkoop, M. and R. Spriensma (1999)
TRACI	2.1	Smog Air	Carter, W. (2007, 2008)

³⁶ Impact category available as all combinations of “excl. biogenic carbon”, “incl. biogenic carbon”, “incl. LUC” and “incl. LUC (LUC only)”

Impact category	Version	Method	Classification and Characterization factor based on
USEtox	2.12	Ecotoxicity (recommended and interim)	USEtox model (Rosenbaum et al. 2008)
USEtox	2.12	Ecotoxicity (recommended only)	USEtox model (Rosenbaum et al. 2008)
USEtox	2.12	Human toxicity, cancer (recommended and interim)	USEtox model (Rosenbaum et al. 2008)
USEtox	2.12	Human toxicity, cancer (recommended only)	USEtox model (Rosenbaum et al. 2008)
USEtox	2.12	Human toxicity, non-canc. (recommended and interim)	USEtox model (Rosenbaum et al. 2008)
USEtox	2.12	Human toxicity, non-canc. (recommended only)	USEtox model (Rosenbaum et al. 2008)
AWARE	1.2C	global average for unspecified water	WULCA (UNEP/SETAC Life Cycle Initiative)
AWARE	1.2C	high characterization factor for unspecified water	WULCA (UNEP/SETAC Life Cycle Initiative)
AWARE	1.2C	low characterization factor for unspecified water	WULCA (UNEP/SETAC Life Cycle Initiative)
AWARE	1.2C	OECD+BRIC average for unspecified water	WULCA (UNEP/SETAC Life Cycle Initiative)
AWARE	1.2	high characterization factor for unspecified water ³⁷	WULCA (UNEP/SETAC Life Cycle Initiative)
AWARE	1.2	low characterization factor for unspecified water ³⁷	WULCA (UNEP/SETAC Life Cycle Initiative)
AWARE	1.2	OECD+BRIC average for unspecified water ³⁷	WULCA (UNEP/SETAC Life Cycle Initiative)
WAVE+		high characterization factor for unspecified water ³⁷	Berger et al. (2018)
WAVE+		low characterization factor for unspecified water ³⁷	Berger et al. (2018)
WAVE+		OECD+BRIC average for unspecified water ³⁷	Berger et al. (2018)
WSI		high characterization factor for unspecified water ³⁷	Pfister et al. (2009)
WSI		low characterization factor for unspecified water ³⁷	Pfister et al. (2009)
WSI		OECD+BRIC average for unspecified water ³⁷	Pfister et al. (2009)

³⁷ Impact category available as “excl. Hydropower” and “incl. Hydropower” version

9 Appendix C Background information on uncertainty

The following chapter provides background information on uncertainty issues in LCA.

Aspects of data uncertainty due to variability in supply chains

While Chapter 1 addressed data and model uncertainty assuming that the practitioner has been able to select the most appropriate or ‘representative’ datasets for the product system under study, this chapter will attempt to quantify relevant aspects of uncertainty in background data due to its variability concerning technological and geographical representativeness.

As mentioned in the previous chapter, +/-10% uncertainty appears to be the minimum overall uncertainty, even if the model is set up with data of high quality containing few errors.

The model’s degree of representativeness regarding supply chains and technology routes depends on the specific situation under consideration. It varies due to factors including specific supplier companies and geographical/national import situations.

The correlation between the background data and the specific situation at hand can only be answered by performing a primary data collection for each specific supply situation and comparing it with the average situation represented by the background data.

The background data as such may be very precise and of extremely high representativeness within the situation where it was set up. The goal of this chapter is to estimate possible variations in background data due to the mismatch between the average and actual supply chain in a specific situation. To achieve this goal two types of possible misrepresentation introduced by the user of the data are assessed:

- the influence of varying the import/production country
- the influence of varying the technology route in the same country to supply the same material or substance

The analysis focuses on chemical products and intermediate products.

Disclaimer:

The following analyses are specific to the products and datasets available in the GaBi Databases and were done in 2016. The results cannot be generalised to other products or data sources.

Influence of varying import/production country for same technology

The following chemical substances were analyzed for their variability with regard to their geography.

Table U: Chemical substance GaBi datasets that were analyzed for result variability across various countries

Acetic acid from methanol	Hydrogen (Steam reforming fuel oil s)
Acetone by-product phenol methyl styrene (from Cumol)	Hydrogen (Steam reforming natural gas)
Adipic acid from cyclohexane	Maleic anhydride (MA) by-product PSA (by oxidation of xylene)
AH-salt 63% (HMDA via adipic acid)	Maleic anhydride from n-butane
Ammonium sulphate by-product caprolactam	Methyl methacrylate (MMA) spent acid recycling
Benzene (from pyrolysis gasoline)	Methyl methacrylate (MMA) from acetone and hydrogen cyanide
Benzene (from toluene dealkylation)	Methylene diisocyanate (MDI) by-product hydrochloric acid, methanol
Benzene by-product BTX (from reformat)	Phenol (toluene oxidation)
Caprolactam from cyclohexane	Phenol from cumene
Caprolactam from phenol	Phosphoric acid (wet process)
Chlorine from chlorine-alkali electrolysis (amalgam)	Phthalic anhydride (PAA) (by oxidation of xylene)
Chlorine from chlorine-alkali electrolysis (diaphragm)	Propylene glycol over PO-hydrogenation
Chlorine from chlorine-alkali electrolysis (membrane)	Propylene oxide (Cell Liquor)
Ethanol (96%) (hydrogenation with nitric acid)	Propylene oxide (Chlorohydrin process)
Ethene (ethylene) from steam cracking	Propylene oxide by-product t-butanol (Oxirane process)
Ethylbenzene (liquid phase alkylation)	p-Xylene (from reformat)
Ethylene glycol from ethene and oxygen via EO	Toluene (from pyrolysis gasoline)
Ethylene oxide (EO) by-product carbon dioxide from air	Toluene by-product BTX (from reformat)
Ethylene oxide (EO) by-product ethylene glycol	Toluene by-product styrene
Hexamethylene diamine (HMDA) via adipic acid	Toluene diisocyanate (TDI) by-product toluene diamine, hydrochloric acid (phosgenation)
Hydrochloric acid by-product methylene diisocyanate (MDI)	Xylene mix by-product benzene (from pyrolysis gasoline)

These routes were analyzed (as available) concerning process boundary conditions in various countries including:

Australia (AU), Belgium (BE), China (CN), Germany (DE), Spain (ES), France (FR), Great Britain (GB), Italy (IT), Japan (JP), Netherlands (NL), Norway (NO), Thailand (TH), United States (US)

The following figure shows the resulting maximum variations of all analyzed materials and substances. For simplicity, the respective technologies are kept constant and only the country of origin is varied. The figure shows the maximum variability across the various chemicals that have been analyzed, as well as the 90% and 10% percentiles.

Two cases were calculated for each route, assuming that the actual location of the supplier is unknown in a given LCA project. Choosing the dataset with the lowest burden while the one with the highest burden would have been appropriate ('choose min'; uncertainty = (min-max)/max) and vice versa ('choose max'; uncertainty = (max-min)/min). The resulting values are therefore the relative '**worst-case errors**' possible based on the datasets considered.

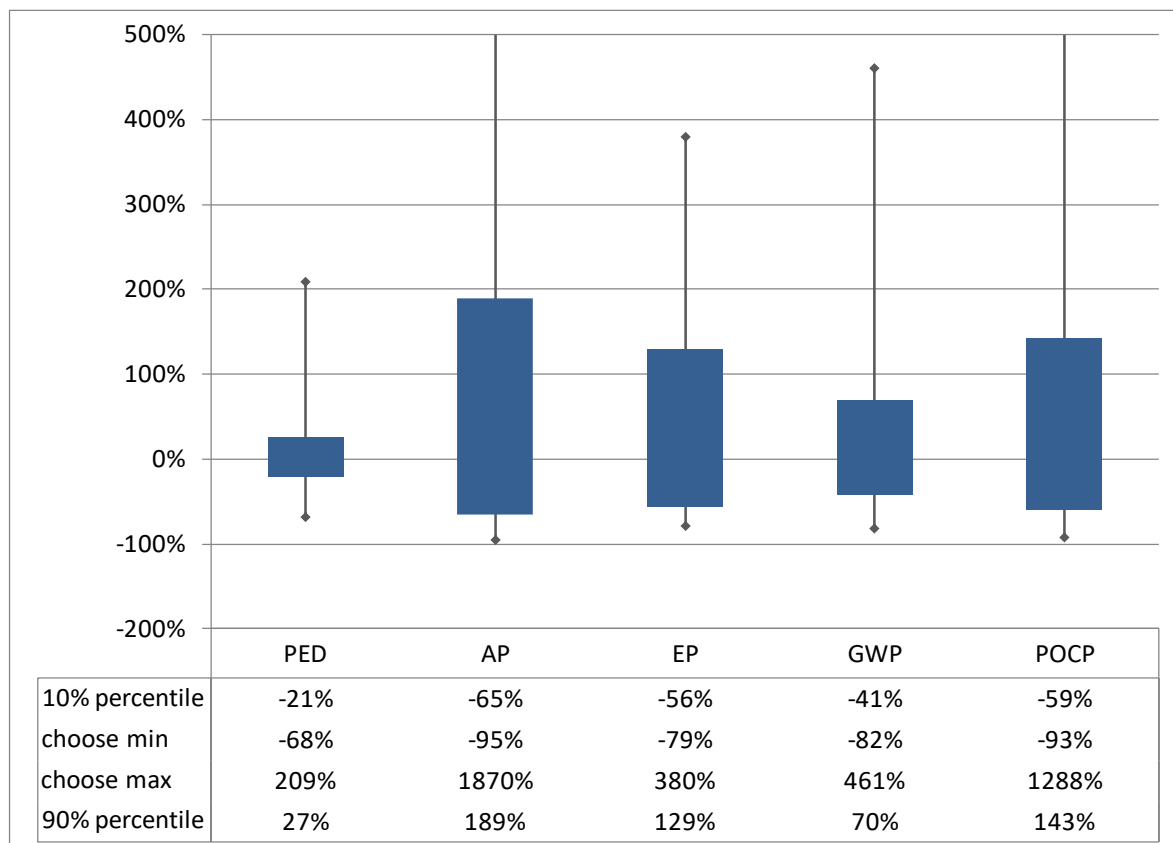

Figure B-12: Maximum errors regarding randomly chosen geography

Figure B-12 shows that when assuming that the technology route for a certain substance is known and the specific country of origin route is not, the maximum uncertainty of the related impacts is between -65% and **+189% for 90% of all chemical substances** for which different country-specific datasets are available in the GaBi Database.

When taking the background information of the GaBi Master DB in to account, the sensitivity concerning the country of origin appears to be more relevant for process chains where energy and the respective emissions from energy supply dominate the impacts. In selected cases, country-specific emissions or synthesis efficiencies and differences in country-specific upstream supply are also relevant.

Influence of varying technology in the same country

The following chemical substances were analyzed regarding their variability with regard to their technology route in the same country.

Table V: Chemical substance GaBi datasets that were analyzed for the result variation across various technology routes

Chlorine from chlorine-alkali electrolysis diaphragm	Ethylene-t-Butylether from C4 and bio ethanol
Chlorine from chlorine-alkali electrolysis membrane	Hexamethylene diamine via Adiponitrile
Chlorine from chlorine-alkali electrolysis amalgam	Hexamethylene diamine via adipic acid
Acetic acid from vinyl acetate	Hydrochloric acid primary from chlorine
Acetic acid from methanol	Hydrochloric acid by-product allyl chloride
Acrylamide catalytic hydrolysis	Hydrochloric acid by-product chlorobenzene
Acrylamide enzymatic hydration	Hydrochloric acid by-product epichlorohydrine
AH salt 63% HMDA from adipic acid	Hydrochloric acid by-product Methylene diisocyanate
AH salt 63% HMDA from acrylonitrile	Hydrogen Cracker
Ammonium sulphate by-product acetone cyanhydrin	Hydrogen Steam reforming fuel oil s
Ammonium sulphate by-product Caprolactam	Hydrogen Steam reforming natural gas
Benzene from pyrolysis gasoline	Maleic anhydride from n-butane
Benzene from toluene dealkylation	Maleic anhydride by-product phthalic anhydride
Benzene by-product BTX	Maleic anhydride from benzene
Benzene by-product ethine	Methyl methacrylate from acetone and hydrogen cyanide
Butanediol from ethine, H2 Cracker, allotherm	Methyl methacrylate spent acid recycling
Butanediol from ethine H2 Steam ref. natural gas, autotherm	Oleic acid from palm oil
Chlorodifluoroethane from 1,1,1-Trichloroethane	Oleic acid from rape oil
Chlorodifluoroethane by-product Dichloro-1-fluoroethane	Phenol by toluene oxidation
Dichloropropane by-product epichlorohydrin	Phenol by-product acetone
Dichloropropane by-product dichloropropane	Phosphoric acid (54%)

Ethanol catalytic hydrogenation with phosphoric acid	Phosphoric acid (100%)
Ethanol hydrogenation with nitric acid	Propylene oxide Cell Liquor
Ethylene glycol by-product Ethylene oxide	Propylene oxide Chlorohydrin process
Ethylene glycol of Ethene + oxygen via EO	Propylene oxide Oxirane process
Ethylene glycol from Ethyleneoxide	Toluene from pyrolysis gasoline
Ethylene oxide by-product carbon dioxide	Toluene by-product BTX
Ethylene oxide by-product ethylene glycol via CO2/methane	Toluene by-product styrene
Ethylene oxide by-product ethylene glycol via CO2/methane with CO2 use	Xylene from pyrolysis gasoline
Ethylene-t-Butylether from C4	Xylene from reformat

The following figure shows the resulting maximum errors across all analyzed materials and substances. Here, the respective countries of origin are kept constant and only the technology route is varied. The figure shows the maximum errors across the various chemicals analyzed, as well as the 90% and 10% percentiles.

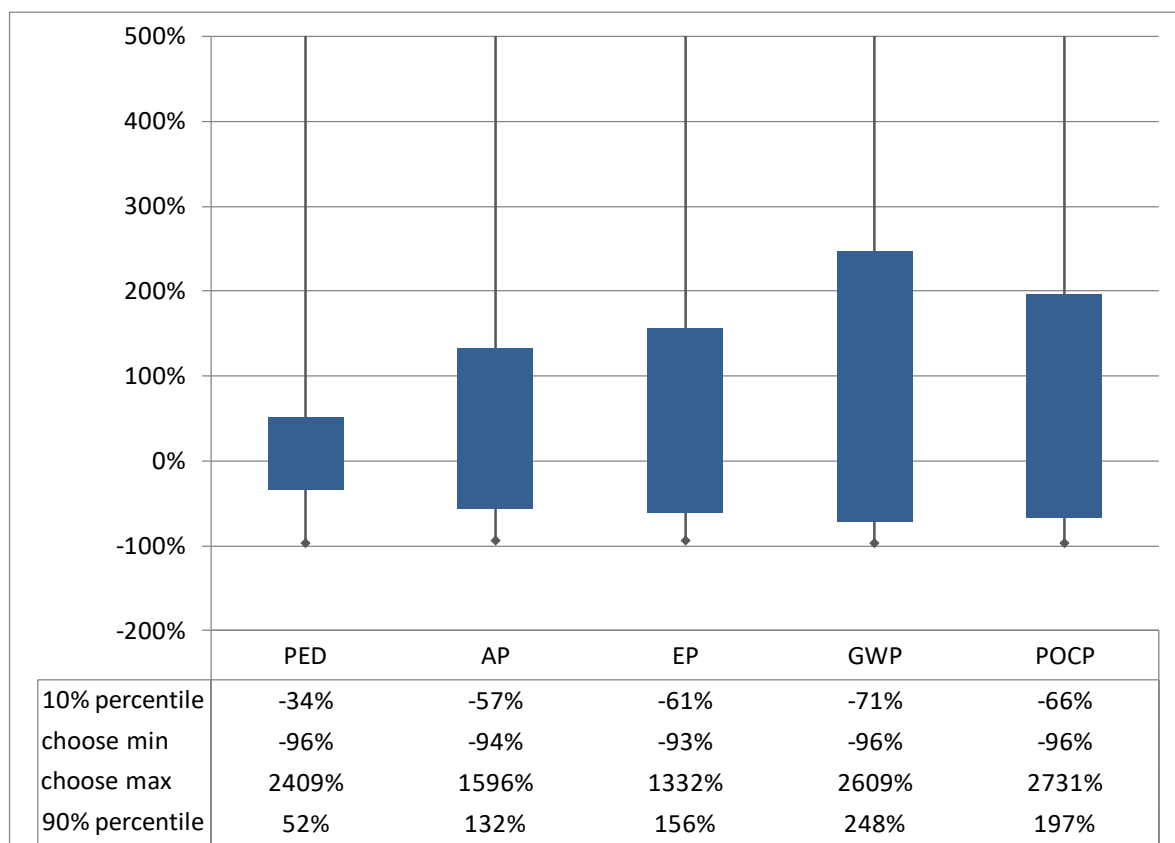

Figure B-13:Maximum errors regarding randomly chosen technology

Again, two cases were calculated for each country, assuming that the actual technology route of the supplier is unknown in a given LCA project: choosing the technology-specific dataset with the lowest burden while the one with the highest burden would have been appropriate ('choose min';

uncertainty = (min-max/max)) and vice versa ('choose max'; uncertainty = (max-min)/min). The resulting values are therefore again the relative '**worst-case errors**' possible based on the available datasets.

Figure B-13 shows that when assuming that the country of origin for a certain substance is known and the specific technology route is not, the errors of the related impacts falls **between -71% and +248% for 90% of all chemical substances** for which different technologies are available in the GaBi Database. Comparing the values to the ones in the previous part concerning geography, it is fair to state that it is worse to have an undefined specific technology route than an undefined country of origin, since all values are higher for the latter.



www.sphera.com

www.gabi-software.com

For more information contact us at:

<https://sphera.com/contact-us>

© 2021 Sphera. All Rights Reserved.