

ON-VEHICLE REPAIR FRONT TIMING CHAIN CASE

Exploded View

INFOID:000000006059294

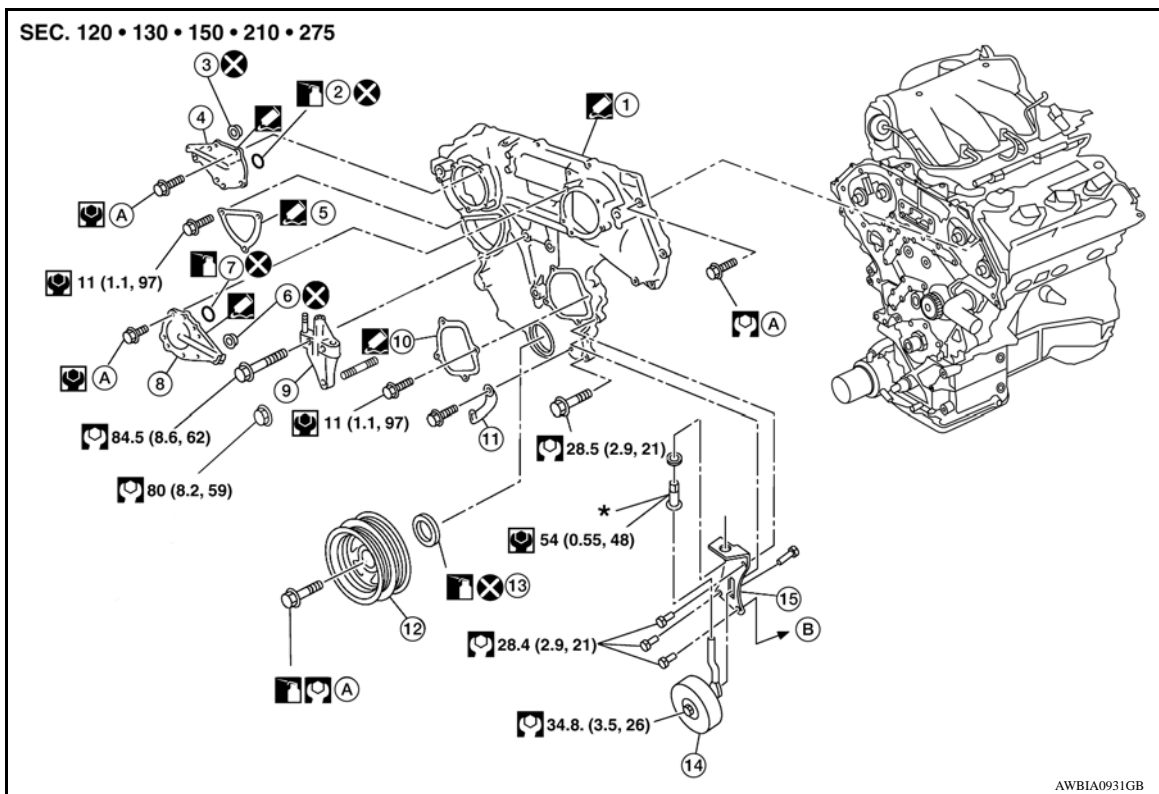

- | | | |
|-------------------------------|-------------------------------|-------------------------------|
| 1. Front timing chain case | 2. Seal ring | 3. Collared O-ring |
| 4. IVT control valve cover RH | 5. Chain tensioner cover | 6. Collared O-ring |
| 7. Seal ring | 8. IVT control valve cover LH | 9. RH engine mounting bracket |
| 10. Water pump cover | 11. Water hose clamp | 12. Crankshaft pulley |
| 13. Front oil seal | 14. Idler pulley | 15. Idler pulley bracket |
| A. Refer to Installation | B. To A/C compressor | |

Removal and Installation

INFOID:000000006059295

REMOVAL

1. Remove engine under cover. Refer to Service Manual, EI Section.
2. Drain the engine oil. Refer to Service Manual, LU Section.
3. Drain the engine coolant from the radiator. Refer to Service Manual, CO Section.
4. Drain the power steering fluid. Refer to Service Manual, PS Section.
5. Remove engine room cover.
6. Remove front air duct. Refer to Service Manual, EM Section.

FRONT TIMING CHAIN CASE

[VQ35DE]

< ON-VEHICLE REPAIR >

7. Remove battery tray. Refer to Service Manual, SC Section.
8. Remove upper radiator hose.
9. Disconnect engine coolant reservoir hose from the radiator and remove engine coolant reservoir.
10. Remove cooling fan assembly. Refer to Service Manual, CO Section.
11. Disconnect lower radiator hose from engine.
12. Disconnect the power steering fluid reservoir tank hose from the power steering pump and fluid cooler and remove the power steering fluid reservoir tank. Refer to Service Manual, PS Section.
13. Remove the front RH wheel and tire. Refer to Service Manual, WT Section.
14. Remove the fender protector side cover RH. Refer to Service Manual, EI Section.
15. Remove the drive belt. Refer to Service Manual, EM Section.
16. Remove the power steering pump. Refer to Service Manual, PS Section.
17. Remove the lower oil pan. Loosen the lower oil pan bolts using power tool in order as shown.

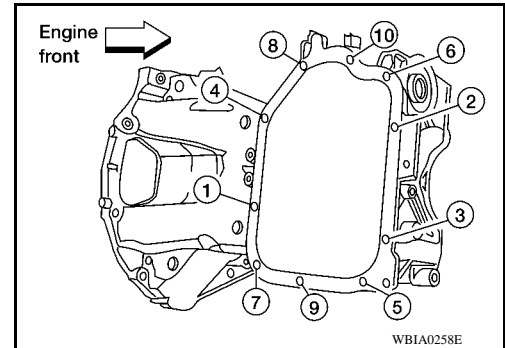

- a. Cut the sealant using Tool and remove the lower oil pan.

Tool number : KV10111100 (J-37228)

CAUTION:

- Be careful not to damage the mating surface.
- Do not insert a screwdriver, this will damage the mating surfaces.

- b. Slide the Tool by tapping its side with a hammer to remove the lower oil pan.

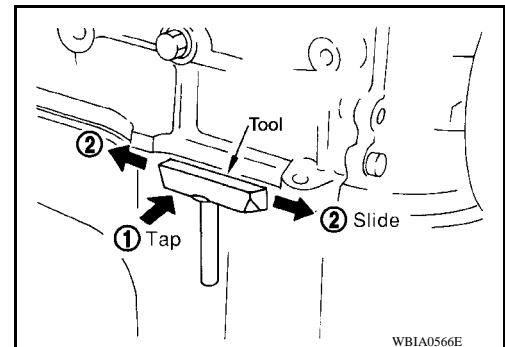

18. Remove upper oil pan bolts in reverse order as shown.

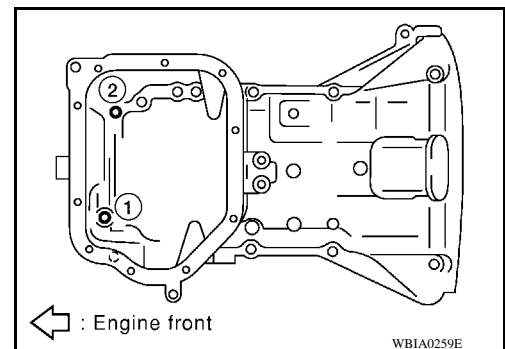

19. Remove the generator. Refer to Service Manual, SC Section.
20. Remove the A/C compressor bolts and position the A/C compressor aside. Refer to Service Manual, ATC or MTC Section.
21. Remove the generator bracket. Refer to Service Manual, SC Section.
22. Support the engine with suitable jack and remove the RH engine, mount and bracket. Refer to Service Manual, EM Section.
23. Remove the crankshaft pulley as follows:
 - a. Remove access plate and install Ring Gear Stopper Tool.

FRONT TIMING CHAIN CASE

< ON-VEHICLE REPAIR >

[VQ35DE]

Tool number : — (J-50288)

CAUTION:

Do not damage the ring gear teeth, or the signal plate teeth behind the ring gear, when setting the Tool.

- b. Loosen crankshaft pulley bolt so that there is a 10 mm (0.39 in) gap between bolt and crankshaft pulley.

CAUTION:

Do not remove crankshaft pulley bolt. Keep loosened crankshaft pulley bolt in place to protect the crankshaft pulley from dropping.

- c. Position a suitable tool at recess hole of crankshaft pulley to remove crankshaft pulley.

CAUTION:

Do not use a puller claw on the outside edge of the crankshaft pulley.

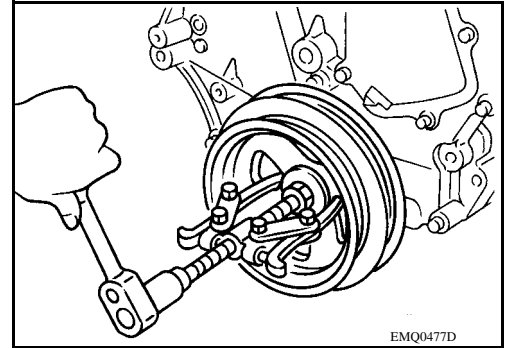

24. Disconnect the oil pressure switch harness connector.
25. Disconnect valve timing control harness connector.
26. Remove the Bank 1 (RH) (A) and Bank 2 (LH) (B) IVT control valve covers.

- Loosen the IVT control valve cover bolts in the reverse order as shown.

CAUTION:

The shaft in the IVT control valve cover is inserted into the center hole of the intake camshaft sprocket. Remove the IVT control valve cover by pulling straight out until the IVT control valve cover disengages from the camshaft sprocket.

- A: Bank 1 (Conventional RH bank)
- B: Bank 2 (Conventional LH bank)
- C: Dowel pin hole

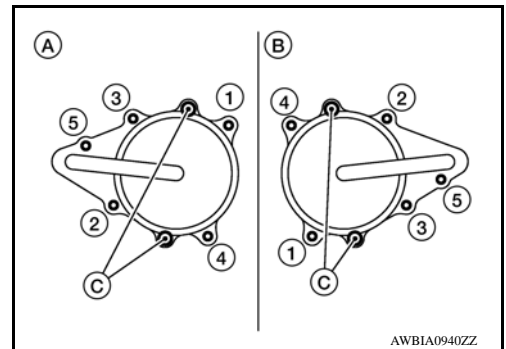

27. Remove the A/C idler pulley and bracket and the drive belt auto-tensioner.
28. If necessary, remove the idler pulley and water pump cover.
29. Remove the front timing chain case.

- a. Loosen the front timing chain case bolts in the order as shown.

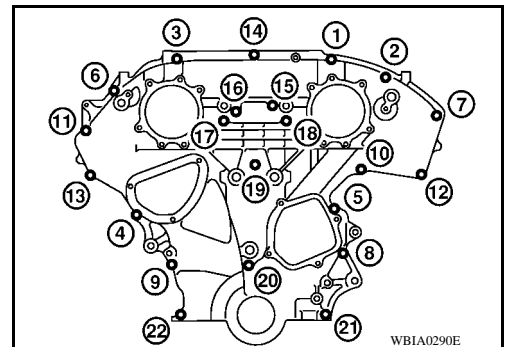

FRONT TIMING CHAIN CASE

[VQ35DE]

< ON-VEHICLE REPAIR >

- b. Insert the appropriate size tool into the notch (1) at the top of the front timing chain case as shown.
- c. Pry off the case by moving the suitable tool (2) as shown.

- Cut liquid gasket for removal using Tool.

CAUTION:

- Do not use a screwdriver or similar tool.
- After removal, handle carefully so it does not bend, or warp under a load.

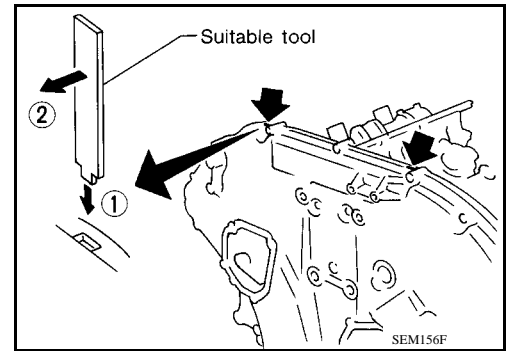

30. Remove O-rings from rear timing chain case.

CAUTION:

Use new O-rings for installation.

31. Remove the front oil seal from the front timing chain case using a suitable tool.

CAUTION:

Do not damage the front cover.

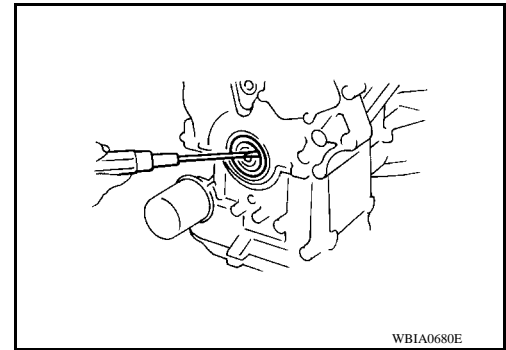

32. Remove all old Silicone RTV Sealant from all the bolt holes and bolts.

CAUTION:

Do not damage the threads or mating surfaces.

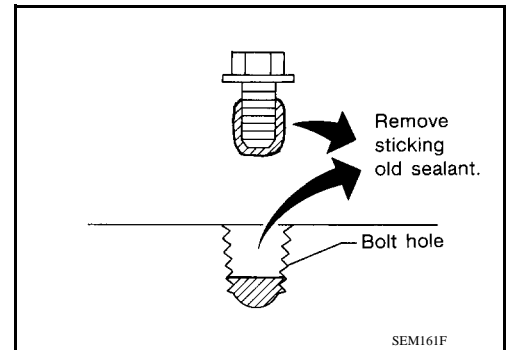

33. Use a scraper to remove all of the old Silicone RTV Sealant from the front timing chain case and opposite mating surfaces.

CAUTION:

Do not damage the mating surfaces.

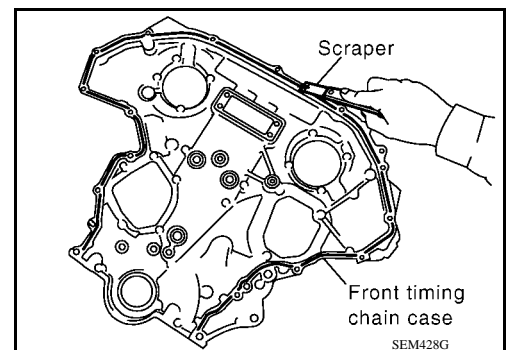

INSTALLATION

FRONT TIMING CHAIN CASE

[VQ35DE]

< ON-VEHICLE REPAIR >

1. Install dowel pins (right and left) into front timing chain case up to a point close to taper in order to shorten protrusion length.

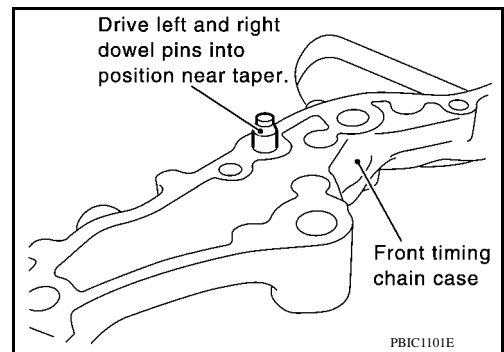

2. Install the new front oil seal on the front timing chain case. Apply new engine oil to the oil seal edges.

NOTE:

Install it so that each seal lip is oriented as shown.

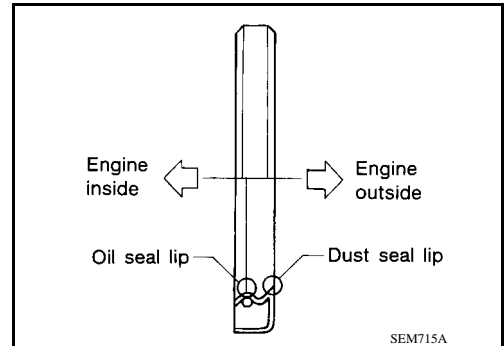

- a. Install the new front oil seal so that it becomes flush with the face with front timing chain case using suitable drift.

CAUTION:

Press fit straight and avoid causing burrs or tilting the oil seal.

NOTE:

Make sure the garter spring is in position and seal lip is not inverted.

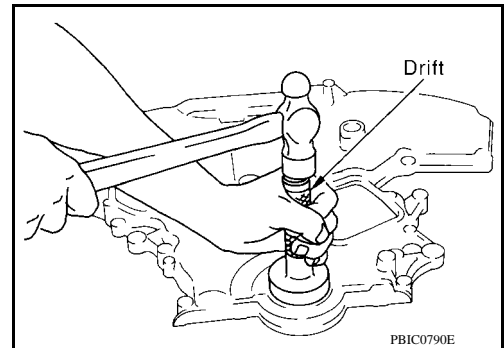

3. Install new O-rings on rear timing chain case.

CAUTION:

Use new O-rings for installation.

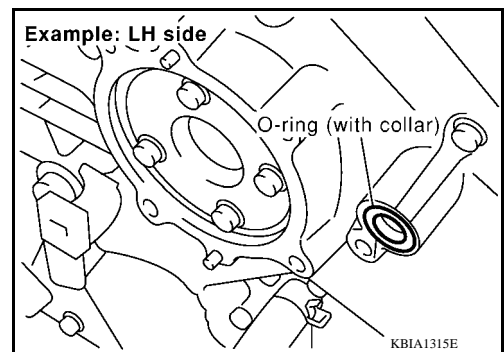

FRONT TIMING CHAIN CASE

[VQ35DE]

< ON-VEHICLE REPAIR >

4. Apply Silicone RTV Sealant to front timing chain case as shown.
- Use Genuine Silicone RTV Sealant, or equivalent. Refer to Service Manual, GI Section.
 - Before installation, wipe off the protruding sealant.
 - 2.6 - 3.6 mm (0.102 - 0.142 in) dia.

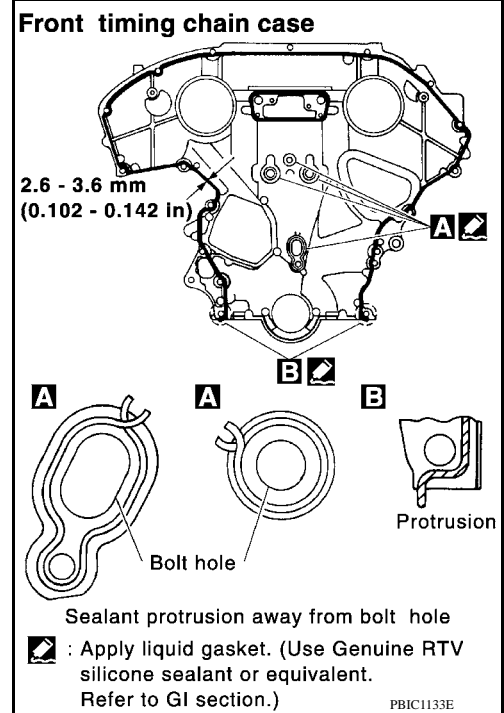

5. Apply Silicone RTV Sealant to top surface of oil pan (upper) as shown.
- Use Genuine Silicone RTV Sealant, or equivalent. Refer to XX-XX. *****.

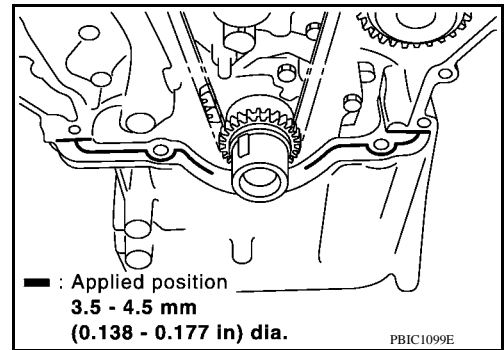

6. Install front timing chain case.
- a. Install lower end of front timing chain case tightly onto top surface of oil pan (upper).

CAUTION:

Be careful that oil pan gasket is in place.

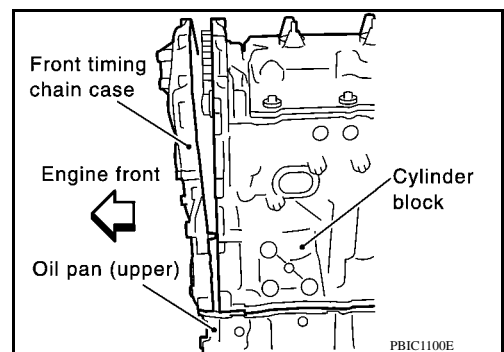

- b. While pressing front timing chain case from its front and top as shown, hammer dowel pin until the outer end becomes flush with surface using suitable tool.
- Install dowel pin on the rear timing chain case into dowel pin hole in front timing chain case.

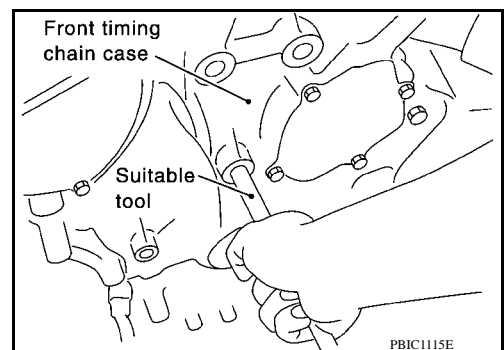

FRONT TIMING CHAIN CASE

< ON-VEHICLE REPAIR >

[VQ35DE]

7. Loosely install the front timing chain case bolts.

Bolt position	Bolt diameter
1, 2	: 8 mm (0.31 in)
3 – 22	: 6 mm (0.24 in)

8. Tighten the front timing chain case bolts in the order as shown.

- Retighten the front timing chain case bolts in the order as shown.

Bolt position	Tightening specification
1, 2	: 28.5 N·m (2.9 kg·m, 21 ft·lb)
3 – 22	: 12.8 N·m (1.3 kg·m, 9 ft·lb)

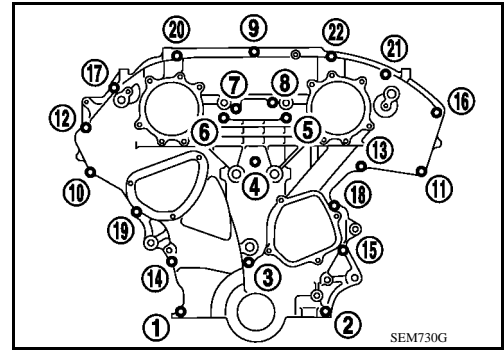

9. Install upper oil pan bolts as shown.

Upper oil pan bolts : 22.0 N·m (2.2 kg·m, 16 ft·lb)

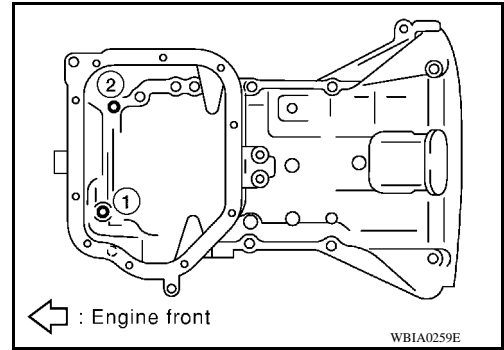

10. Install lower oil pan. Refer to Service Manual, EM Section.

11. Install IVT control valve covers as follows:

a. Install new collared O-rings in front cover oil hole (LH and RH sides).

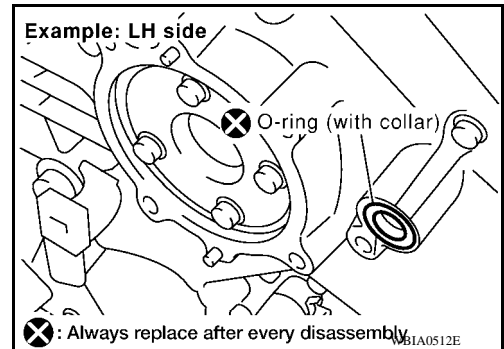

b. Install new seal rings on the IVT control valve covers.

c. Apply Silicone RTV Sealant to the IVT control valve covers.

- Use Genuine Silicone RTV Sealant, or equivalent. Refer to Service Manual, GI Section.

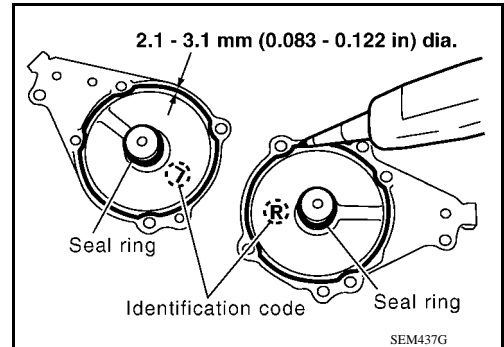

FRONT TIMING CHAIN CASE

[VQ35DE]

< ON-VEHICLE REPAIR >

- Being careful not to move the seal ring from the installation groove, align the dowel pins on the chain case with the holes to install the IVT control valve covers.
- Tighten the intake valve timing control valve cover bolts in the order as shown.
- A: Bank 1 (Conventional RH bank)
- B: Bank 2 (Conventional LH bank)
- C: Dowel pin hole

IVT control valve cover bolts : 11.3 N·m (1.2 kg-m, 100 in-lb)

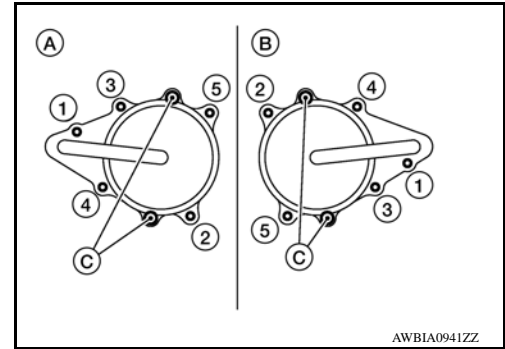

- Apply liquid gasket and install the water pump cover, if removed.
 - Use Genuine Silicone RTV Sealant or equivalent. Refer to Service Manual, GI Section.
- Install crankshaft pulley and tighten the bolt in two steps.
 - Lubricate thread and seat surface of the bolt with new engine oil.
 - Apply a paint mark for the second step of angle tightening.

Step 1 : 44 N·m (4.5 kg-m, 32 ft-lb)
Step 2 : 84° - 90° degrees clockwise

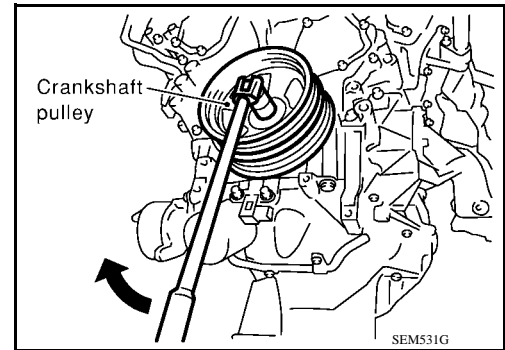

- Remove the Ring Gear Stopper Tool.

Tool number : — (J-50288)

CAUTION:

Do not damage the ring gear teeth, or the signal plate teeth behind the ring gear, when removing the Tool.

- Rotate crankshaft pulley in normal direction (clockwise when viewed from front) to confirm it turns smoothly.
- Installation of the remaining components is in reverse order of removal.

Inspection After Installation

INFOID:000000006059296

- Before starting engine, check oil/fluid levels including engine coolant and engine oil. If less than required quantity, fill to the specified level. Refer to Service Manual, MA Section.
- Use procedure below to check for fuel leakage.
- Turn ignition switch ON (with engine stopped). With fuel pressure applied to fuel piping, check for fuel leakage at connection points.
- Start engine. With engine speed increased, check again for fuel leakage at connection points.
- Run engine to check for unusual noise and vibration.
- Warm up engine thoroughly to make sure there is no leakage of fuel, exhaust gas, or any oils/fluids including engine oil and engine coolant.
- Bleed air from passages in lines and hoses, such as in cooling system.
- After cooling down engine, again check oil/fluid levels including engine oil and engine coolant. Refill to specified level, if necessary.
- Summary of the inspection items:

Item		Before starting engine	Engine running	After engine stopped
Engine coolant		Level	Leakage	Level
Engine oil		Level	Leakage	Level
Transmission/ transaxle fluid	A/T and CVT Models	Leakage	Level/Leakage	Leakage
	M/T Models	Level/Leakage	Leakage	Level/Leakage

FRONT TIMING CHAIN CASE

[VQ35DE]

< ON-VEHICLE REPAIR >

Other oils and fluids*	Level	Leakage	Level
Fuel	Leakage	Leakage	Leakage
Exhaust gas	—	Leakage	—

*Power steering fluid, brake fluid, etc.

TIMING CHAIN

< ON-VEHICLE REPAIR >

[VQ35DE]

TIMING CHAIN

Exploded View

INFOID:00000006059297

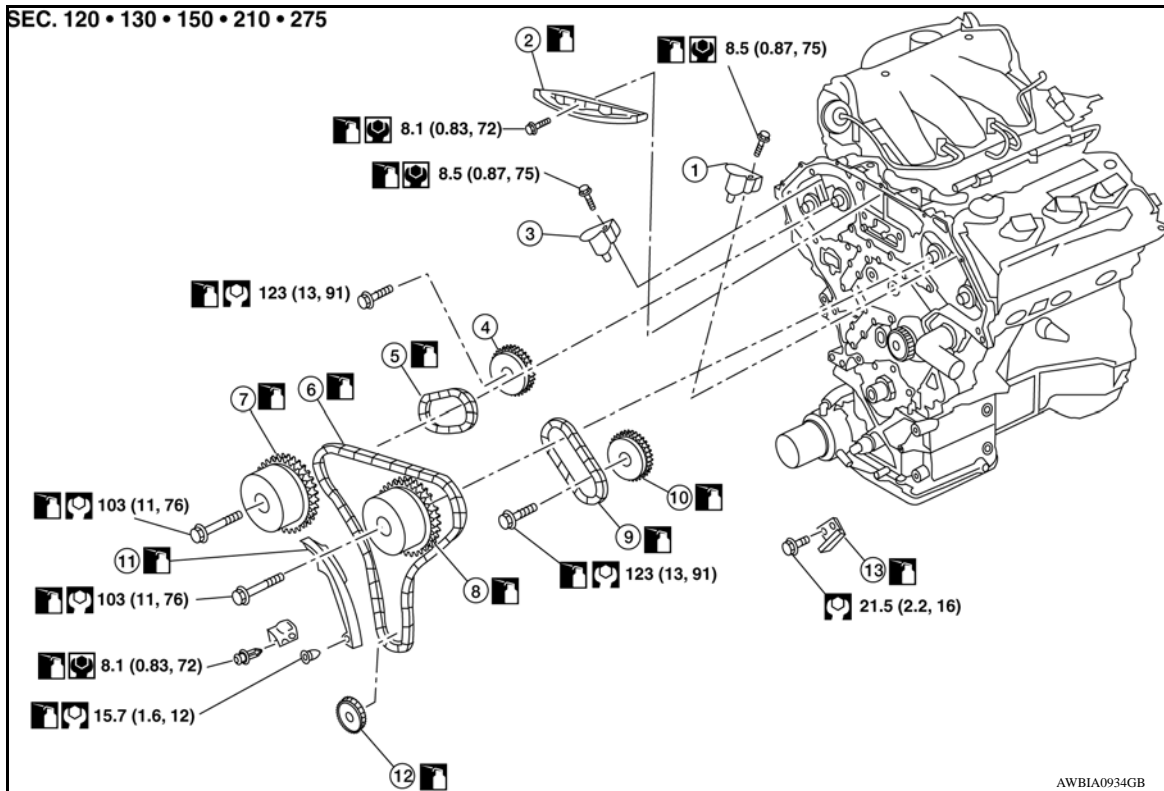

- | | | |
|--|-------------------------------|--|
| 1. Timing chain tensioner (secondary) (LH) | 2. Internal chain guide | 3. Timing chain tensioner (secondary) (RH) |
| 4. Camshaft sprocket RH (EXH) | 5. Timing chain (secondary) | 6. Timing chain (primary) |
| 7. Camshaft sprocket RH (INT) | 8. Camshaft sprocket LH (INT) | 9. Timing chain (secondary) |
| 10. Camshaft sprocket LH (EXH) | 11. Slack guide | 12. Crankshaft sprocket |
| 13. Tension guide | | |

CAUTION:

- After removing timing chains, do not turn the crankshaft and camshaft separately, or the valves will strike the pistons.
- When installing camshafts, chain tensioners, oil seals, or other sliding parts, lubricate contacting surfaces with new engine oil.
- Apply new engine oil to bolt threads and seat surfaces when installing camshaft sprockets, camshaft brackets, and crankshaft pulley.

NOTE:

It is not necessary to remove the rocker covers or intake manifold collector to remove or install the timing chain(s).

TIMING CHAIN

< ON-VEHICLE REPAIR >

[VQ35DE]

INFOID:000000006059298

Removal

1. Set No. 1 cylinder to TDC.
 - Rotate crankshaft pulley clockwise to align timing mark (grooved line without color) with timing indicator.

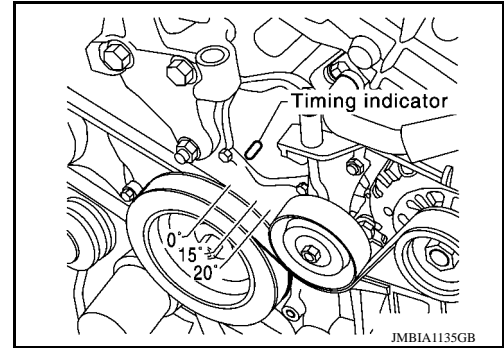

2. Remove front timing chain case. Refer to EM-1, Front Timing Chain Case.
3. Check timing chain markings to confirm No. 1 cylinder is at TDC of its compression stroke.
 - If not, remove Ring Gear Stopper Tool and turn crankshaft clockwise 360° (one revolution).
 - Re-install Ring Gear Stopper Tool.

Tool number : — (J-50288)

- If the original timing chain markings are not legible, use paint or equivalent to mark the timing chains to the sprockets.
4. If removing the timing chains (secondary), loosen camshaft sprocket bolts.
 5. Compress the timing chain tensioner (primary).
 - a. Pull lever down and release plunger stopper tab. Plunger stopper tab can be pushed up to release (coaxial structure with lever).

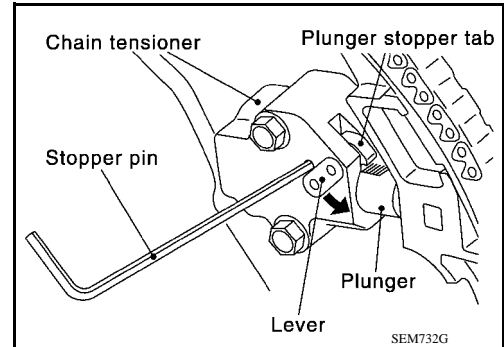

- b. Insert stopper pin into timing chain tensioner (primary) body hole to hold lever, and keep the stopper tab released.
- c. Depress the plunger into the tensioner body by pressing the slack guide.
- d. Keep the slack guide pressed and lock the plunger in by pushing the stopper pin through the lever and into the chain tensioner body hole.
 - Use stopper pin included with Tool J-50246.

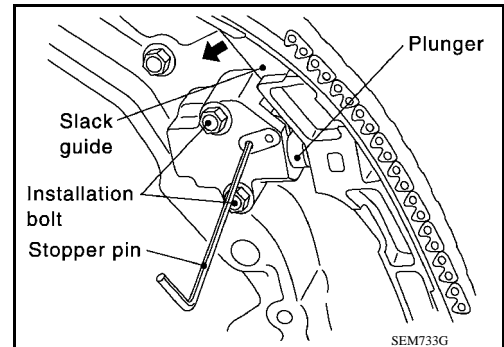

TIMING CHAIN

[VQ35DE]

< ON-VEHICLE REPAIR >

6. Remove the internal chain guide.
 - Slack guide does not need to be removed.

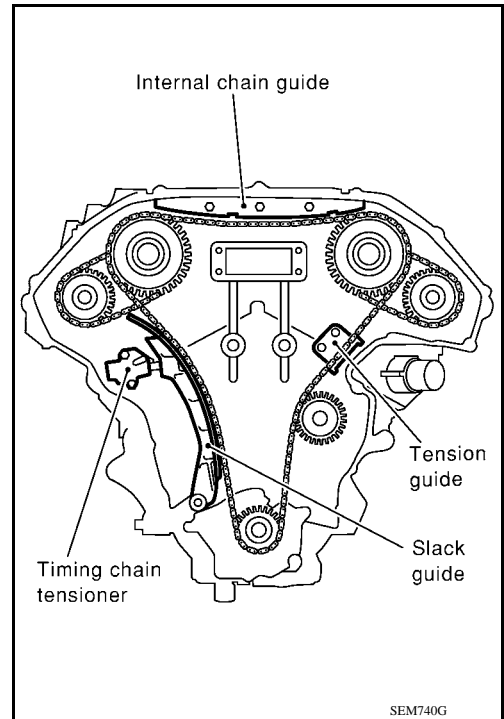

7. Remove timing chain (primary).

CAUTION:

After removing timing chains, do not turn the crankshaft and camshaft separately, or the valves will strike the pistons.

8. Remove crankshaft sprocket, if necessary.
9. Remove timing chain (secondary) and camshaft sprockets as follows:
 - a. Attach stopper pin (B) to the right (A) and left (C) timing chain tensioners (secondary) (1).

NOTE:

- Use stopper pins included with Tool J-50246.

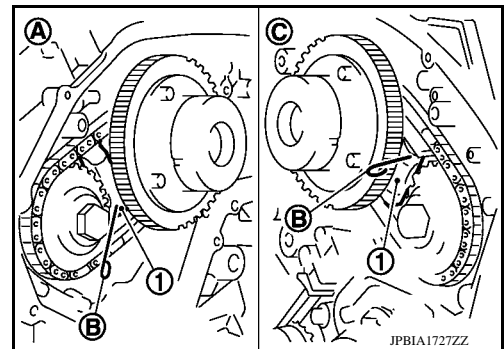

- b. Remove camshaft sprocket (INT and EXH) bolts.
- c. Remove the timing chains (secondary) together with camshaft sprockets (INT) and (EXH).
 - Turn camshaft slightly to secure slack of timing chain on timing chain tensioner (secondary) side.
 - Insert metal or resin plate [0.5 mm (0.020 in)] into guide between timing chain (secondary) and timing chain tensioner (secondary) plunger. Remove camshaft sprocket and timing chain (secondary) with timing chain removed from guide groove.

CAUTION:

Timing chain tensioner plunger can move while stopper pin is inserted in timing chain tensioner. Plunger can come out of tensioner when timing chain is removed. Use caution during removal.

NOTE:

Camshaft sprocket (INT) is a one piece integrated design with sprockets for timing chain (primary) and for timing chain (secondary).

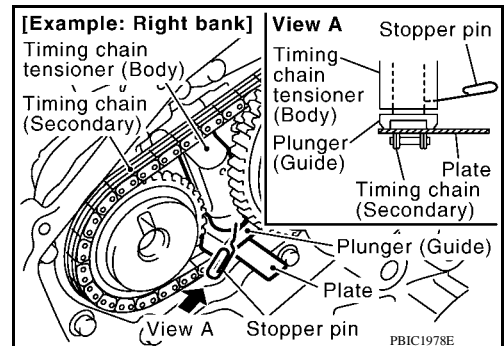

TIMING CHAIN

[VQ35DE]

< ON-VEHICLE REPAIR >

- When handling camshaft sprocket (INT), be careful of the following:
 - CAUTION:**
 - Handle carefully to avoid any shock to camshaft sprocket.
 - Do not disassemble. (Do not loosen bolts (A) as shown).

NOTE:

For removal of timing chain tensioner (secondary), refer to EM-20, Removal and Installation (Secondary Timing Chain Tensioner). [Removing camshaft bracket (No. 1) is required.]

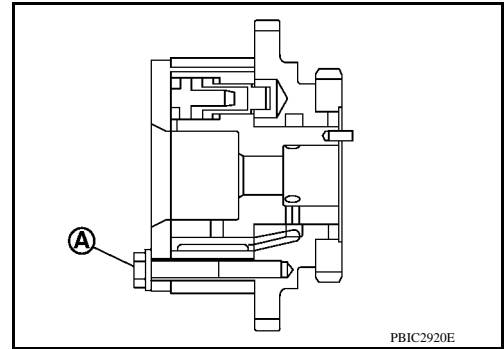

INFOID:000000006059299

Inspection

Check for cracks and any excessive wear at link plates. Replace chain if necessary.

- Inspect all timing chains and associated parts for wear or damage, replace as necessary.

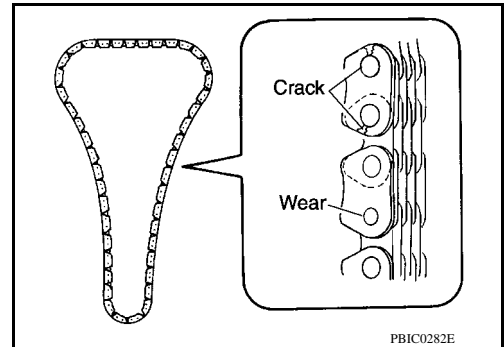

INFOID:000000006059300

Installation

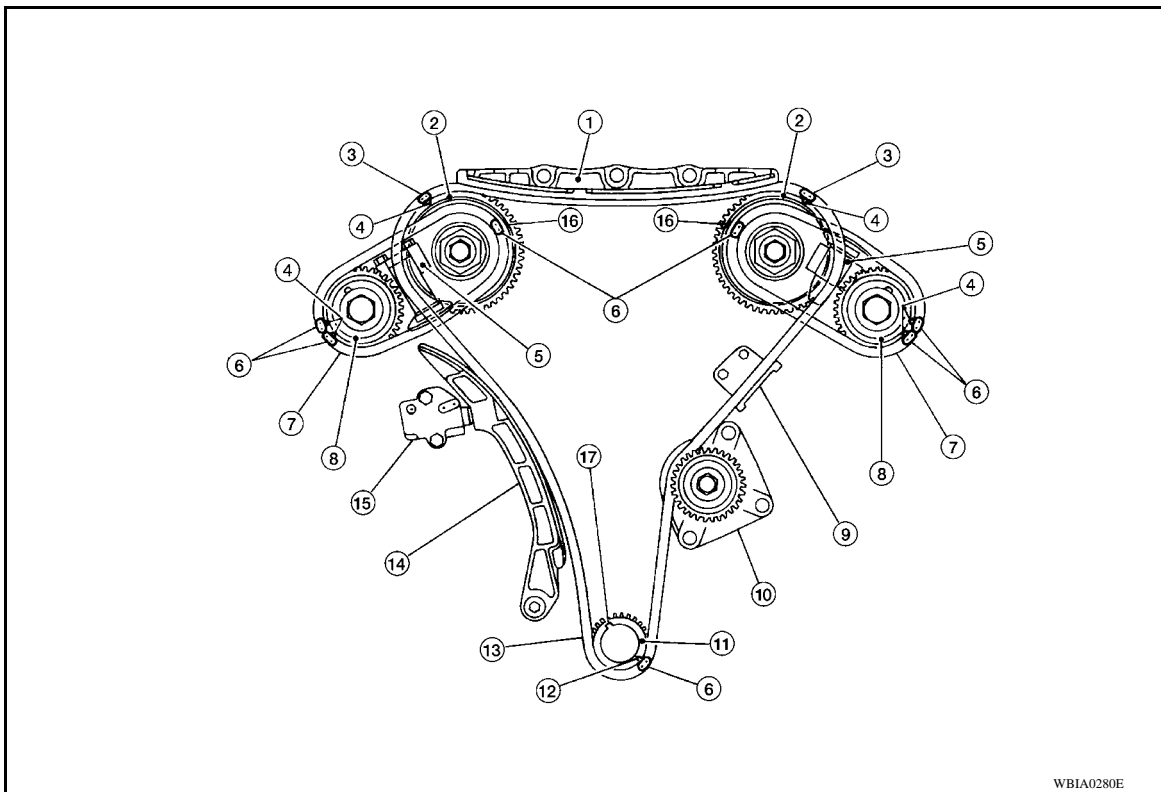

- | | | |
|-----------------------------|---------------------------------------|------------------------------|
| 1. Internal chain guide | 2. Camshaft sprocket (INT) | 3. Mating mark (copper link) |
| 4. Mating mark (punched) | 5. Timing chain tensioner (secondary) | 6. Mating mark (yellow link) |
| 7. Timing chain (secondary) | 8. Camshaft sprocket (EXH) | 9. Tension guide |
| 10. Water pump | 11. Crankshaft sprocket | 12. Mating mark (notched) |

TIMING CHAIN

[VQ35DE]

< ON-VEHICLE REPAIR >

- | | | |
|-----------------------------|--------------------|--------------------------------------|
| 13. Timing chain (primary) | 14. Slack guide | 15. Timing chain tensioner (primary) |
| 16. Mating mark (back side) | 17. Crankshaft key | |

NOTE:

The figure above shows the relationship between the mating mark on each timing chain and that on the corresponding sprocket, with the components installed.

1. Make sure that dowel pin hole, dowel pin of camshaft and crankshaft key are located as shown. (No. 1 cylinder at compression TDC)

• NOTE:

Though camshaft does not stop at the position as shown, for the placement of cam nose, it is generally accepted camshaft is placed for the same direction of the figure.

Camshaft dowel pin hole (intake side)

: At cylinder head upper face side in each bank.

Camshaft dowel pin (exhaust side)

: At cylinder head upper face side in each bank.

Crankshaft key

: At cylinder head side of right bank.

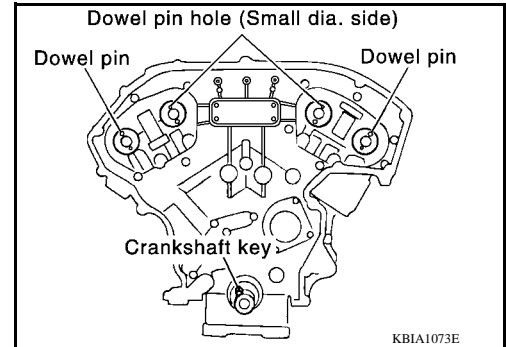

2. Install the timing chains (secondary) and camshaft sprockets as follows:

CAUTION:

Mating marks between timing chain and sprockets slip easily. Confirm all mating mark positions repeatedly during the installation process.

- a. Push plunger of timing chain tensioner (secondary) and keep it pressed in with stopper pin.
 - Use stopper pin included with Tool J-50246.

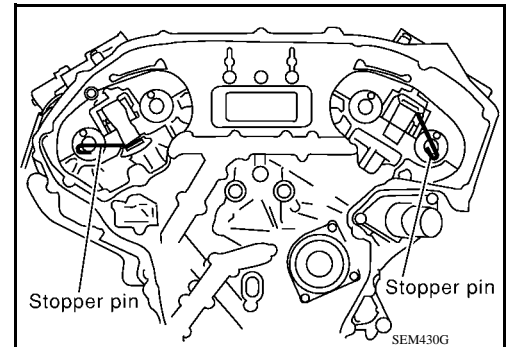

- b. Before installing timing chains (secondary) and camshaft sprockets, confirm mating marks are visible. If necessary, use paint or equivalent to re-mark the camshaft sprockets at each mating mark.

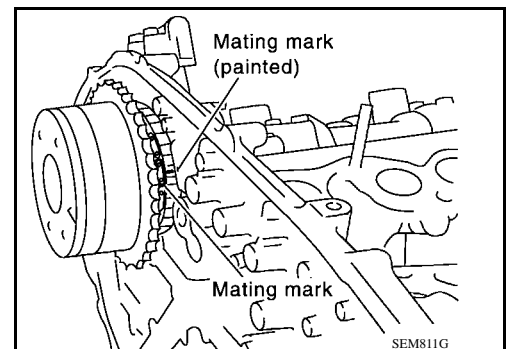

TIMING CHAIN

[VQ35DE]

< ON-VEHICLE REPAIR >

- c. Install timing chains (secondary) (8) and camshaft sprockets [INT (1) and EXH (9)].
- Left bank mating marks (6)
 - Align the timing chain mating marks (secondary) (2) (yellow color link) with the ones on camshaft sprockets (INT and EXH) (4), (5), (7) and (10) (punched), and install them.

NOTE:

- Mating marks for camshaft sprocket (INT) are on the back side of camshaft sprocket (secondary).
- There are two types of mating marks, circle (7), (10) and oval (4), (5) types. They should be used for the right and left banks, respectively.

Right bank : Use circle type (7) and (10).

Left bank : Use oval type (4) and (5).

- Align dowel pin (3) and pin hole on camshafts with the groove (11) and dowel pin on sprockets, and install them.
 - On the intake side, align pin hole on the small diameter side of the camshaft front end with dowel pin (3) on the back side of camshaft sprocket, and install them.
 - On the exhaust side, align dowel pin on camshaft front end with pin groove (11) on camshaft sprocket, and install them.
 - In case that positions of each mating mark and each dowel pin do not fit on mating parts, make fine adjustment to the position by slightly turning camshaft(s).
 - Bolts for camshaft sprockets must be tightened in the next step. Tightening them by hand is enough to prevent the dislocation of dowel pins.
- d. Confirm the mating marks are aligned, then finger tighten camshaft sprocket bolts. Final tightening will be done with all timing chains installed.
- e. Remove stopper pins out from timing chain tensioners (secondary).
3. Install timing chain (primary) as follows:
- a. Install the crankshaft sprocket.
- Make sure the mating marks on the crankshaft sprocket face front of engine.

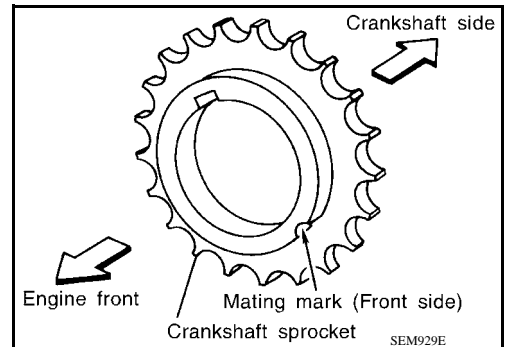
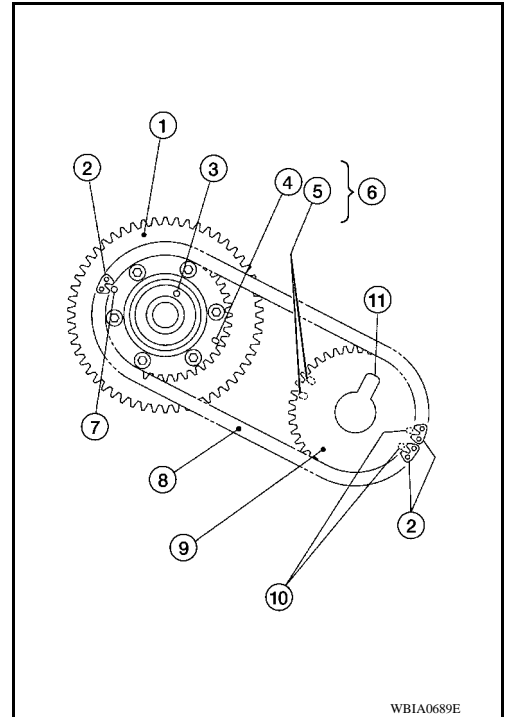

TIMING CHAIN

[VQ35DE]

< ON-VEHICLE REPAIR >

4. Install the timing chain (primary).
- Water pump (G).
 - Install timing chain (primary) so the mating mark (punched) (B) on camshaft sprocket (C) is aligned with the copper link (A) on the timing chain, while the mating mark (notched) (E) on the crankshaft sprocket (D) is aligned with the yellow one (F) on the timing chain, as shown.
 - When it is difficult to align mating marks of the timing chain (primary) with each sprocket, gradually turn the camshaft to align it with the mating marks.
 - During alignment, be careful to prevent dislocation of mating mark alignments of the secondary timing chains.

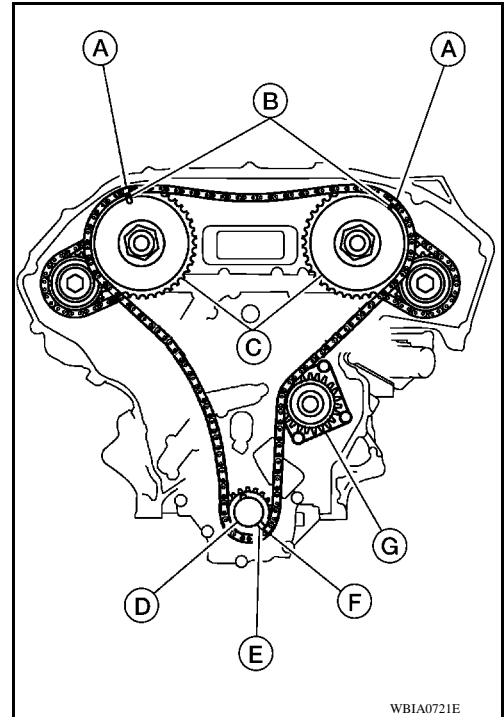

5. Install the internal chain guide.

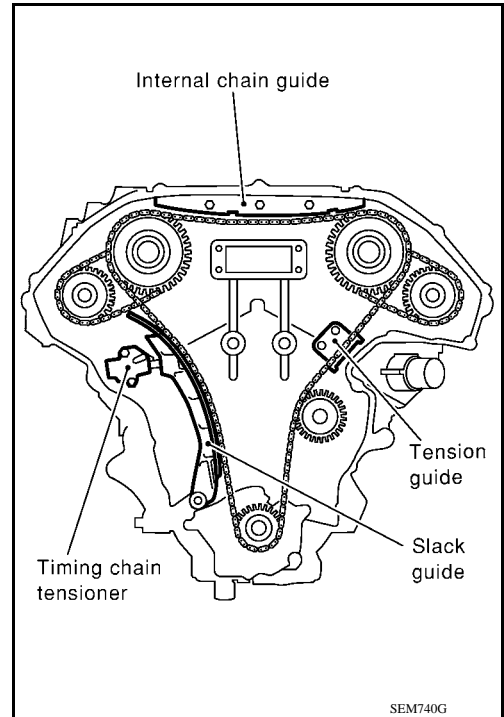

- If removed, reinstall slack guide.

CAUTION:

Do not overtighten slack guide bolts. It is normal for a gap to exist under the bolt seats when bolts are tightened to specification.

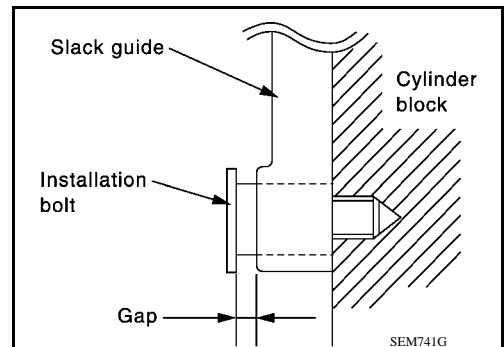

TIMING CHAIN

< ON-VEHICLE REPAIR >

[VQ35DE]

- Remove stopper pin from timing chain tensioner (primary).
6. Make sure again that the matching marks on the sprockets and the timing chain have not slipped out of alignment.
 7. Tighten camshaft sprocket bolts to specification with all timing chains installed and Ring Gear Stopper Tool holding the crankshaft.

Tool number : — (J-50288)

8. Install the front timing chain case. Refer to EM-1, Front Timing Chain Case.

Inspection After Installation

INFOID:000000006114295

- Before starting engine, check oil/fluid levels including engine coolant and engine oil. If less than required quantity, fill to the specified level. Refer to Service Manual, MA Section.
- Use procedure below to check for fuel leakage.
- Turn ignition switch ON (with engine stopped). With fuel pressure applied to fuel piping, check for fuel leakage at connection points.
- Start engine. With engine speed increased, check again for fuel leakage at connection points.
- Run engine to check for unusual noise and vibration.
- Warm up engine thoroughly to make sure there is no leakage of fuel, exhaust gas, or any oils/fluids including engine oil and engine coolant.
- Bleed air from passages in lines and hoses, such as in cooling system.
- After cooling down engine, again check oil/fluid levels including engine oil and engine coolant. Refill to specified level, if necessary.
- Summary of the inspection items:

Item		Before starting engine	Engine running	After engine stopped
Engine coolant		Level	Leakage	Level
Engine oil		Level	Leakage	Level
Transmission/ transaxle fluid	A/T and CVT Models	Leakage	Level/Leakage	Leakage
	M/T Models	Level/Leakage	Leakage	Level/Leakage
Other oils and fluids*		Level	Leakage	Level
Fuel		Leakage	Leakage	Leakage
Exhaust gas		—	Leakage	—

*Power steering fluid, brake fluid, etc.

TIMING CHAIN TENSIONER

< ON-VEHICLE REPAIR >

[VQ35DE]

TIMING CHAIN TENSIONER

Exploded View

INFOID:000000006059301

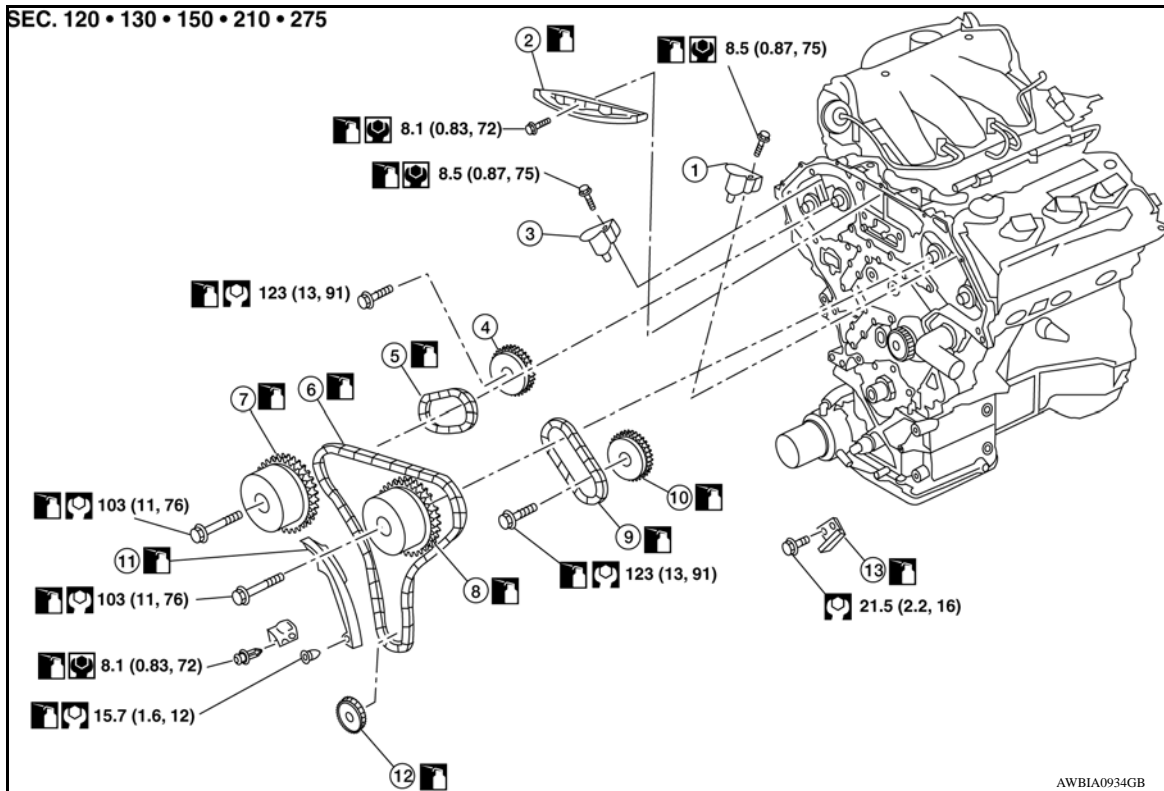

- | | | |
|--|-------------------------------|--|
| 1. Timing chain tensioner (secondary) (LH) | 2. Internal chain guide | 3. Timing chain tensioner (secondary) (RH) |
| 4. Camshaft sprocket RH (EXH) | 5. Timing chain (secondary) | 6. Timing chain (primary) |
| 7. Camshaft sprocket RH (INT) | 8. Camshaft sprocket LH (INT) | 9. Timing chain (secondary) |
| 10. Camshaft sprocket LH (EXH) | 11. Slack guide | 12. Crankshaft sprocket |
| 13. Tension guide | | |

Removal and Installation (Primary Timing Chain Tensioner)

INFOID:000000006059302

REMOVAL

- Remove the front RH wheel and tire. Refer to Service Manual, WT Section.
- Remove the fender protector side cover RH. Refer to Service Manual, EI Section.
- Support the engine with suitable jack and remove the RH engine insulator, mount and bracket. Refer to Service Manual, EM Section.

- Remove the Bank 1 (RH) IVT control valve cover.
 - Loosen the IVT control valve cover bolts in the order as shown.

CAUTION:

The shaft in the IVT control valve cover is inserted into the center hole of the intake camshaft sprocket. Remove the IVT control valve cover by pulling straight out until the IVT control valve cover disengages from the camshaft sprocket.

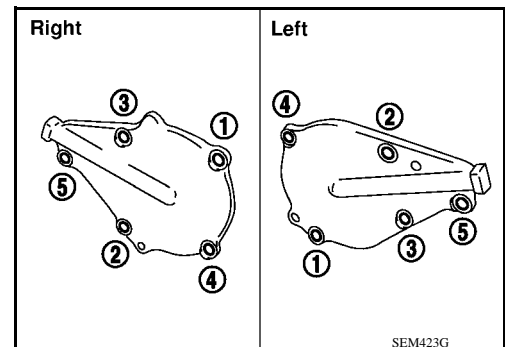

- Remove the primary timing chain tensioner as follows:

TIMING CHAIN TENSIONER

[VQ35DE]

< ON-VEHICLE REPAIR >

- a. Pull the lever (C) down to release the plunger stopper tab (B).
- b. Insert the stopper pin A into the tensioner body hole to hold the lever (C) and keep the plunger stopper tab (B) released.
- c. Compress the plunger (D) into the tensioner body (1) by pressing the slack guide (2).
- d. Keep the slack guide (2) pressed and lock the plunger (D) in by pushing the stopper pin A through the lever (C) and into the chain tensioner body hole.
 - Use stopper pin included with Tool J-50246.
- e. Remove timing chain tensioner bolts and then remove the timing chain tensioner.

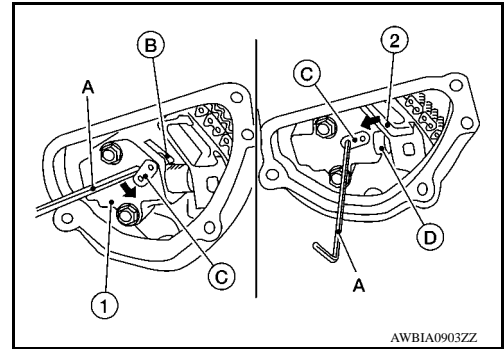

CAUTION:

Be careful not to drop timing chain tensioner bolts inside timing chain case.

INSTALLATION

Installation is in the reverse order of removal.

- When installing primary timing chain tensioner, push in plunger and keep it pressed in with stopper pin.
- Remove any dirt and foreign materials completely from the back and the mounting surfaces of primary timing chain tensioner.
- After installation, pull out stopper pin.
- When installing the IVT control valve covers perform the following steps.

1. Install IVT control valve covers as follows:

- a. Install new collared O-rings in front cover oil hole (LH and RH sides).

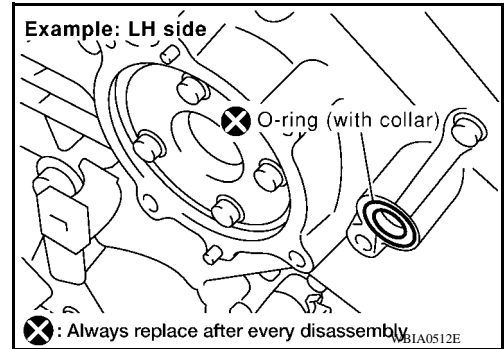

- b. Install new seal rings on the IVT control valve covers.
- c. Apply Silicone RTV Sealant to the IVT control valve covers.
 - Use Genuine Silicone RTV Sealant, or equivalent. Refer to Service Manual, GI Section.

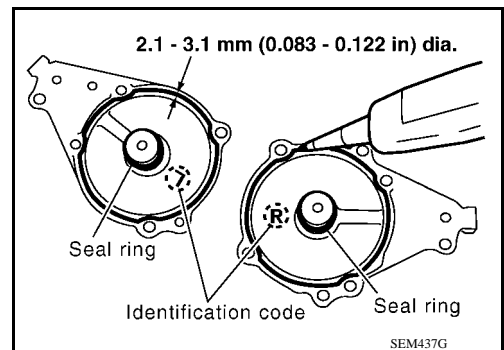

- Being careful not to move the seal ring from the installation groove, align the dowel pins on the chain case with the holes to install the IVT control valve covers.
- Tighten the intake valve timing control valve cover bolts in the order as shown.

IVT control valve cover bolts : 11.3 N·m (1.2 kg-m, 100 in-lb)

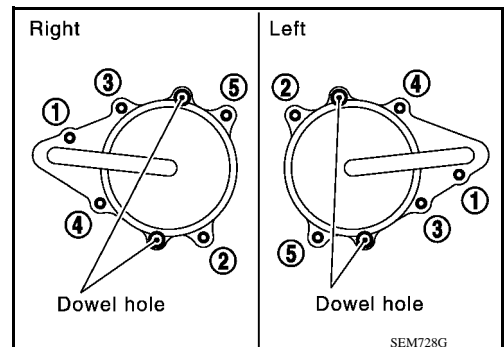

TIMING CHAIN TENSIONER

< ON-VEHICLE REPAIR >

[VQ35DE]

Removal and Installation (Secondary Timing Chain Tensioner)

INFOID:000000006059303

REMOVAL

1. Remove the timing chains (primary) and (secondary). Refer to EM-10, Timing Chain.
2. Remove the rocker covers. Refer to Service Manual, EM Section.
3. Remove the camshaft brackets (No. 1). Refer to Service Manual, EM Section.
4. Remove the secondary timing chain tensioners.

INSTALLATION

Installation is in the reverse order of removal.

Removal and Installation (Secondary Timing Chain Tensioner Shoe)

INFOID:000000006059304

REMOVAL

1. Remove the timing chains (secondary). Refer to EM-10, Timing Chain.
2. Remove the secondary timing chain tensioner shoe by evenly prying at base of shoe with suitable tool as shown.

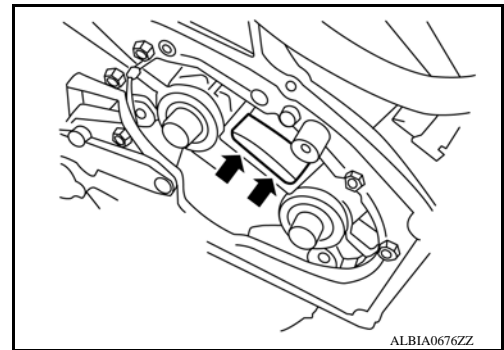

INSTALLATION

1. Install new secondary timing chain tensioner shoe using Tool (A) as shown.
 - Tighten the bolt until the secondary timing chain tensioner shoe is fully seated on the secondary timing chain tensioner.

CAUTION:

Do not overtighten bolt.

Tool number : — (J-50246)

2. Installation of the remaining components is in the reverse order of removal.

