

Miyano

BNE42 / 51

Fixed Headstock Type CNC Automatic Lathe

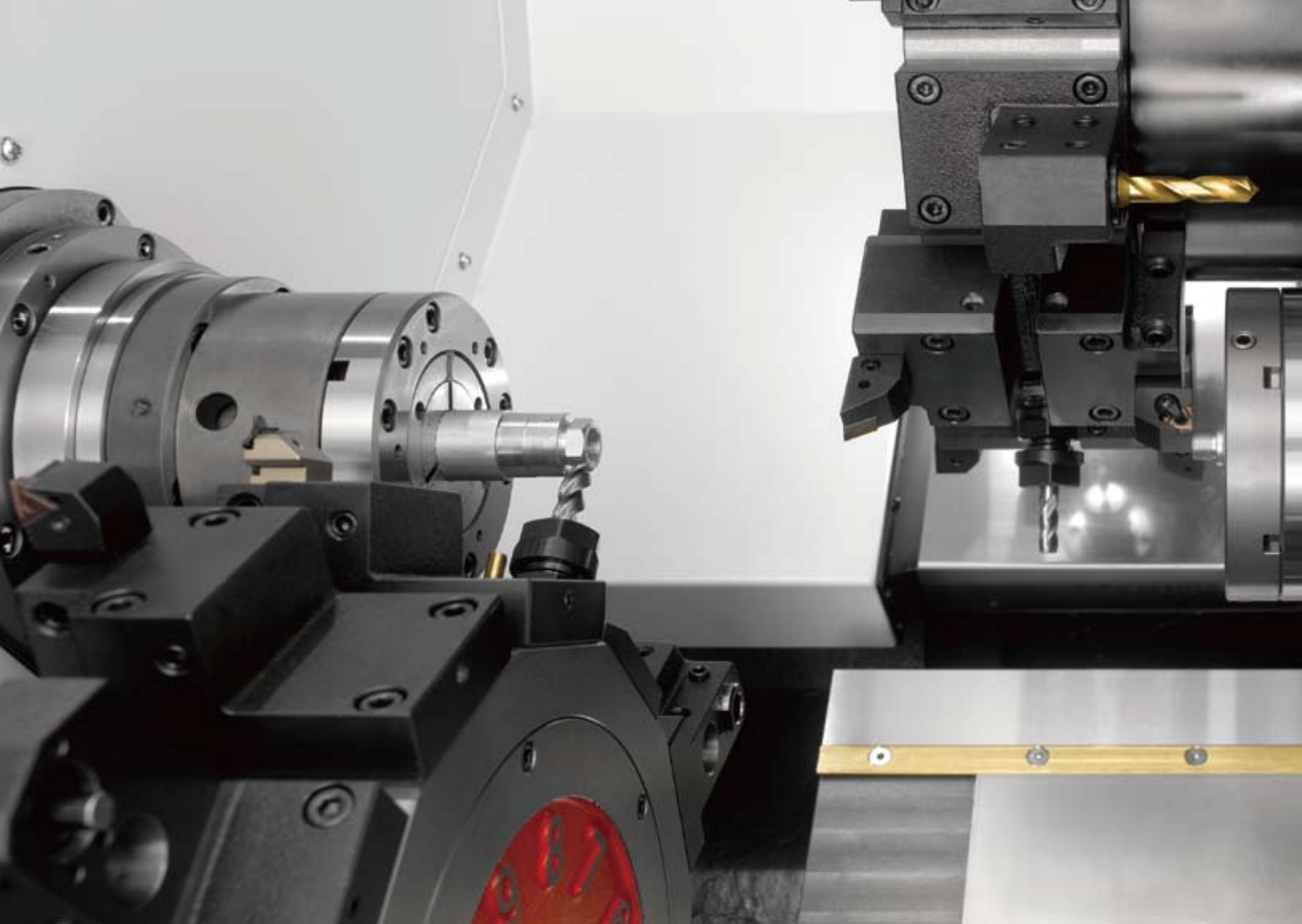



SY

Y Axis on Turret HD1

In addition to front / back integrated machining and multiple cutting achievable by the 2-spindle and 2-turret specification machines, the Y axis installed on turret HD1 (SY type) enables a greater variety of complex machining.

Ample Tool Stations

Installation of double tool holders on the 12-station turret allows two tools to be mounted at a single position, so you will never feel short of tools. (Common to S/SY types)

Powerful Tool

Revolving tools featuring a powerful machining torque of 20 Nm and high rotational speeds of up to 6,000 min⁻¹ can be mounted at all positions (12 positions) with independent drive. (Common to S/SY types)



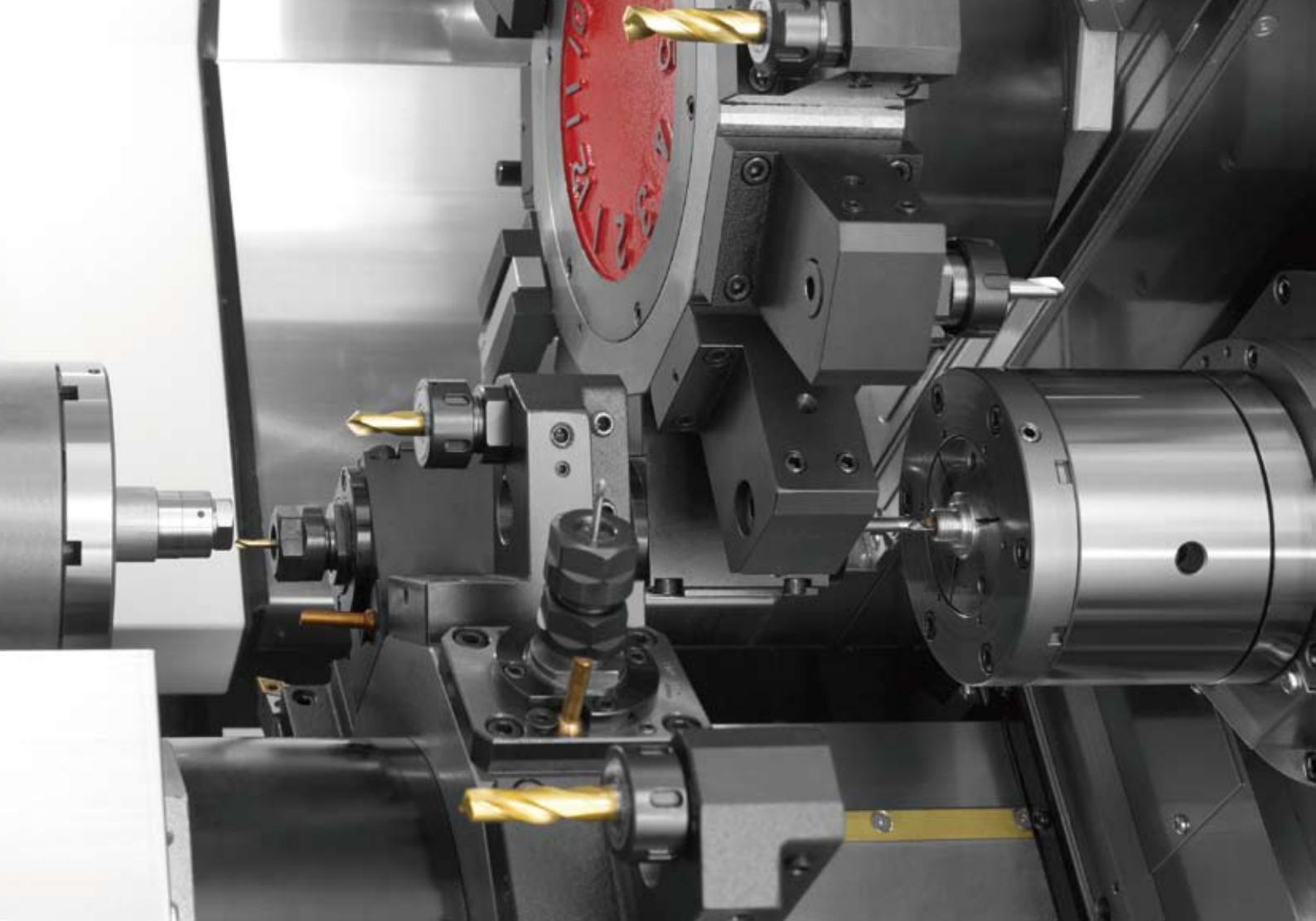

S

Two Spindle Capacities

BNE42 42mm

BNE51 51mm

and two versions S without Y axis and SY with Y axis to turret HD 1.

Revamped NC Unit

The new 31i-B NC unit simplifies the operation panel with less push buttons and support screens including "Machining Data", "Start Conditions" and "Tool Monitor" (option) enable further improvements in productivity by faster set-ups. (Common to S/SY types)

Newly Designed Covers

All the covers have been reviewed in detail and redesigned to improve ease of operation, including changing the splash guard to open inside the fixed cover. (Common to S/SY types)



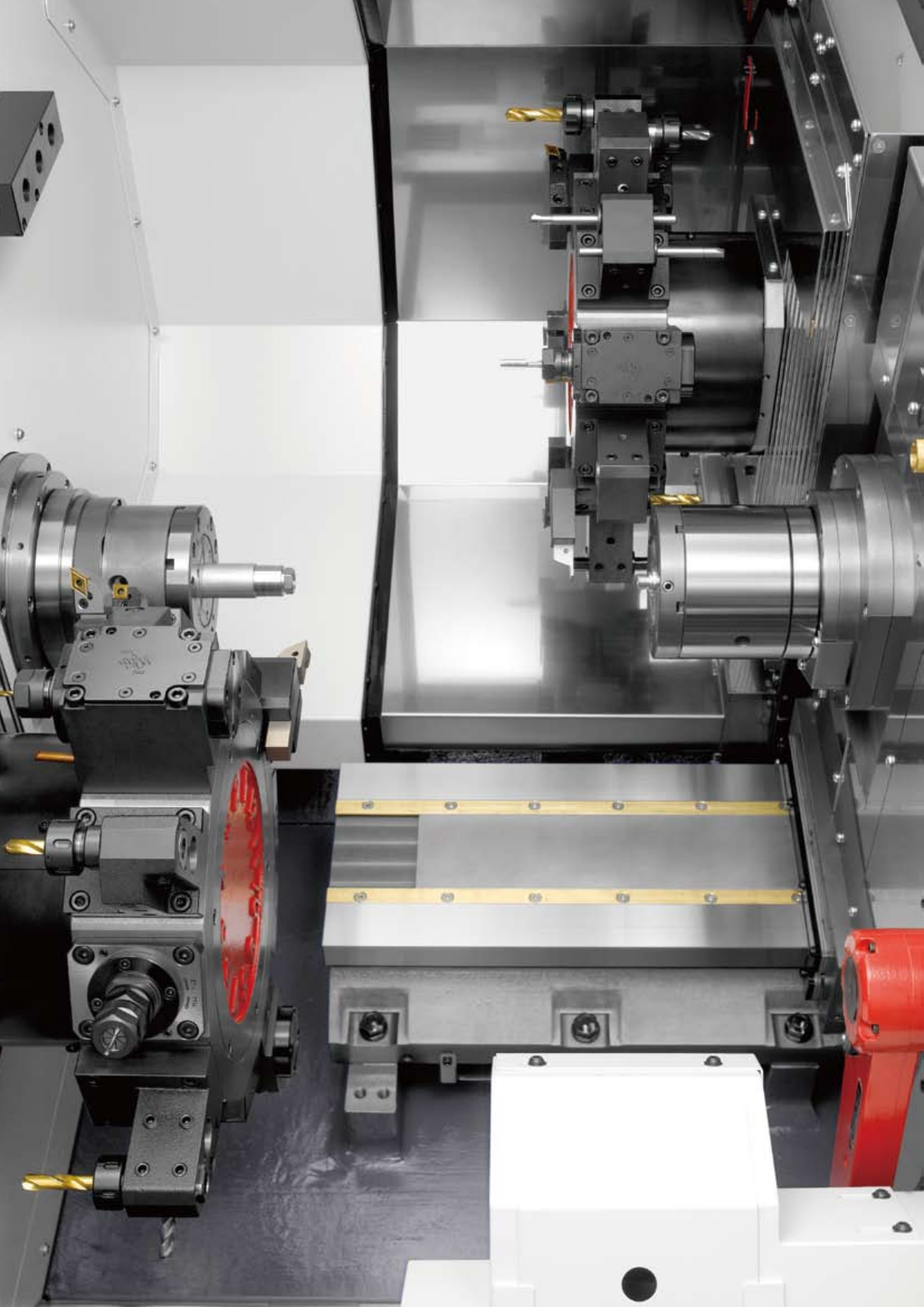

Strong Construction

The basic construction of the machine, that is the combination of the highly rigid precision scraped square guideways and the heavy slanted bed cast in one piece, is the base to support high precision, heavy cutting and long tool life even in complex machining.

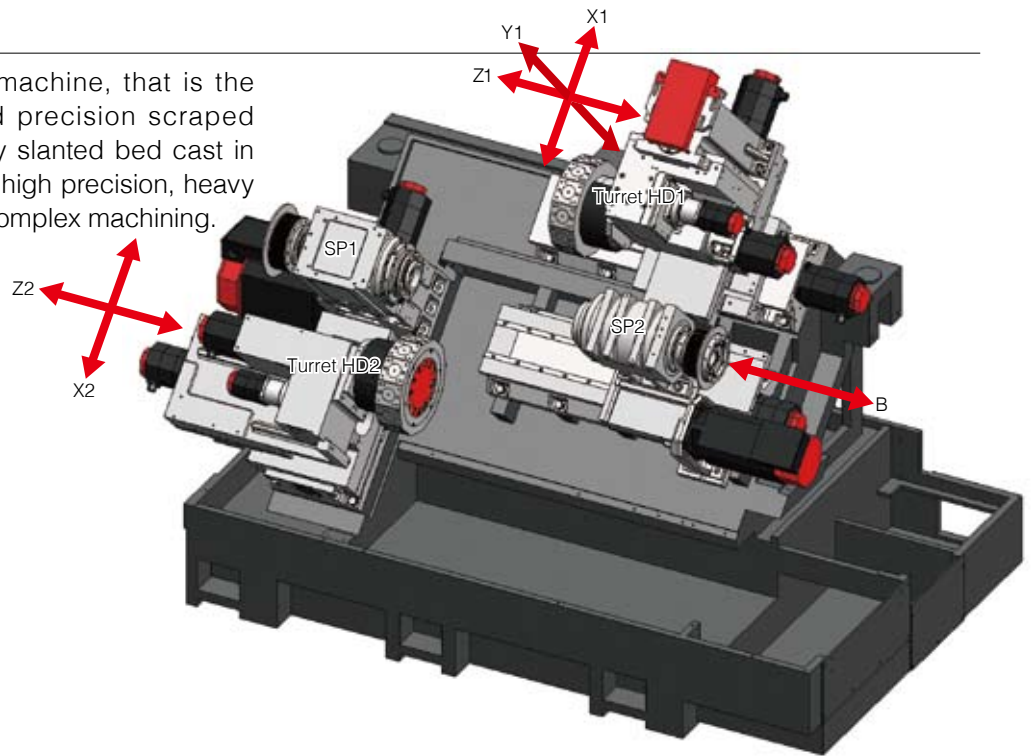

Turret

Indexing by a large-diameter curvic coupling, secure hydraulic turret clamping and rugged square guideways assure high precision and long life of the turret without compromise. This turret can accommodate revolving tools with a high machining torque of 20 Nm at all 12 positions.

Our unique tool holder mounting method using two location pins makes it easy to mount and remove tool holders and ensures exceptionally high re-mounting accuracy.

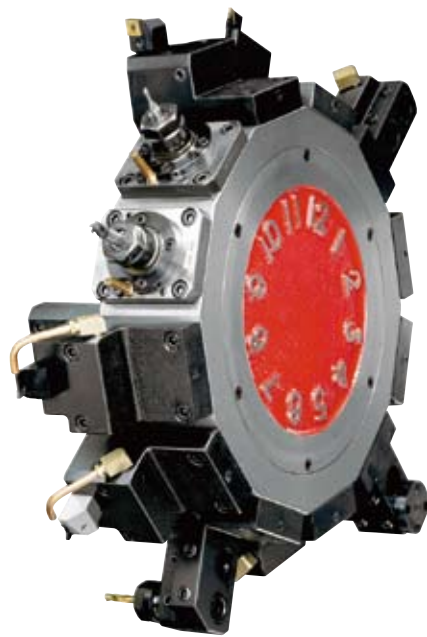

Spindle

The main spindle of the 51S / 51SY is supported by “ultra precision double-row cylindrical roller bearings” and “ultra precision angular contact ball bearings” at the front and by “ultra precision double-row cylindrical roller bearings” at the rear to suppress radial run-out and thermal displacement in the longitudinal direction as well as to provide high rigidity. This precision spindle is installed in a ground, high-precision quill type housing.

This spindle structure maintains sufficient rigidity to allow powerful machining and ensures stable thermal displacement characteristics thanks to less heat generation.

All spindles are manufactured in the dedicated in-house production line and undergo extended bench testing before being assembled into the machine to provide the stable machining accuracy for which Miyano is renowned.

Sectional view of type 51 spindle

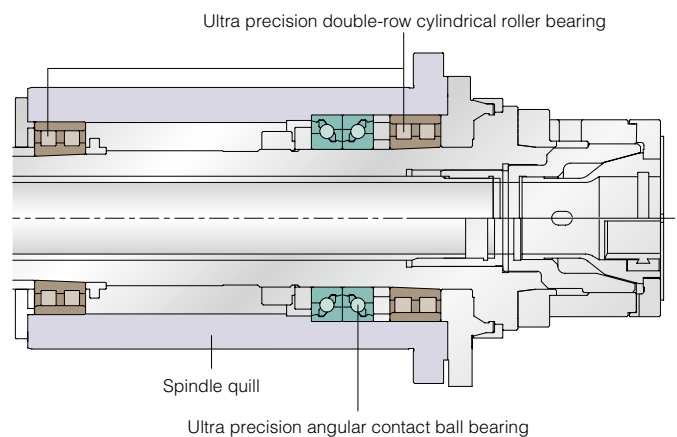

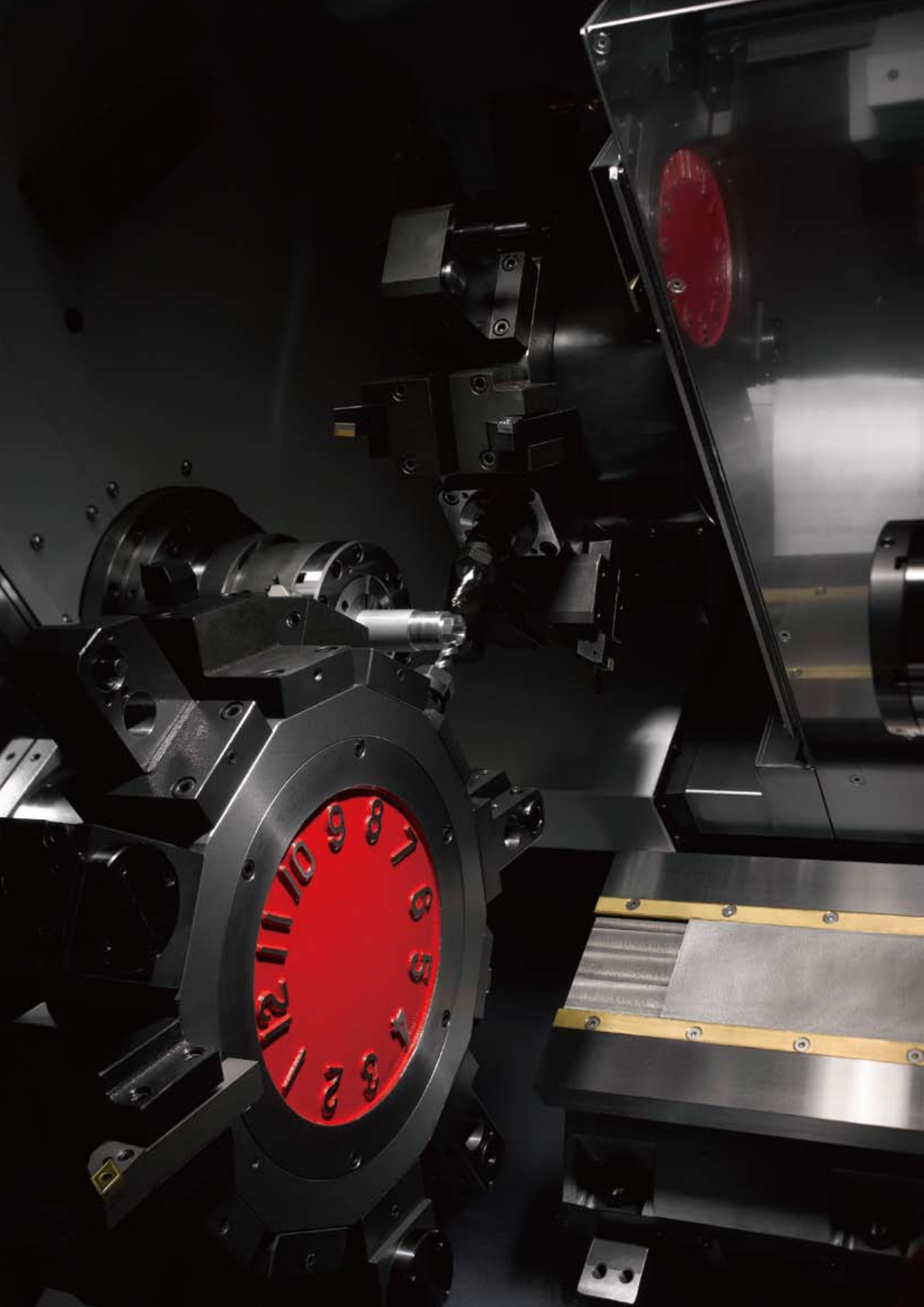

Machining Examples



Polygon machining (Optional)
Synchronizing the revolving tool speed with the spindle speed at two times permits polygon machining, such as two-, four- and six-sided machining, with a polygon cutter.



Large-diameter thread cutting using helical interpolation (Optional)
Large-diameter thread cutting can be done with a planetary tap using the helical interpolation function. (SY type)



Differential velocity cutting by revolving tools
In multiple cutting of inner and outer diameters, the optimum cutting speed can be obtained by controlling the revolving tool speed. A small-diameter drill is rotated in the forward direction to increase the relative speed between the drill and the workpiece, while a large-diameter drill is rotated in the reverse direction to decrease the relative speed.

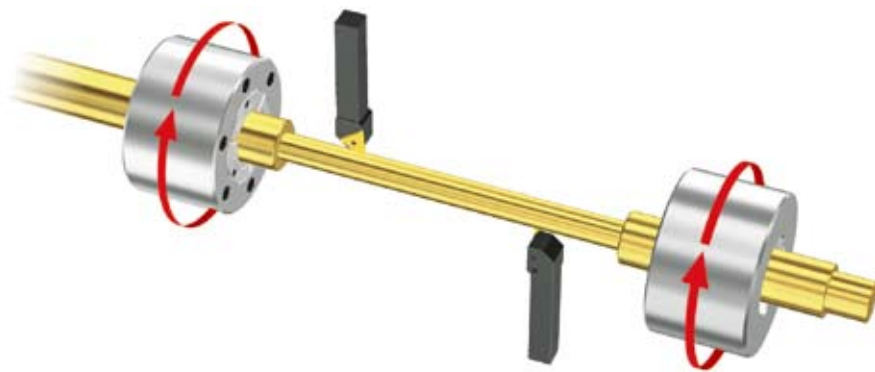

Long-shaft machining
The bar stock machined on the L spindle is pulled out by the R spindle and chucked in synchronization by the L and R spindles at the same time. Simultaneous machining / simultaneous complex machining is performed and then the workpiece is cut off. After that the machining at the R spindle side is performed and the finished product is pushed out of the R spindle by the next workpiece.

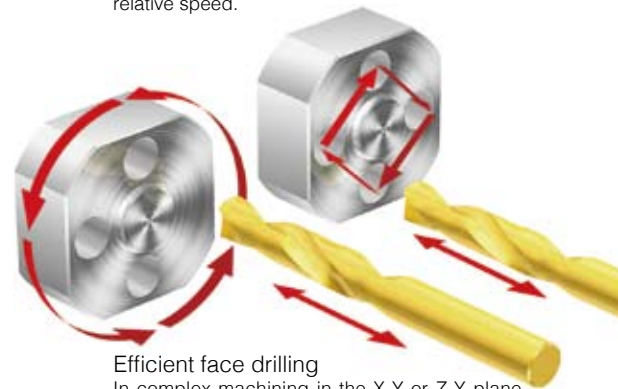

Efficient face drilling
In complex machining in the X-Y or Z-Y plane, using C axis control to index the drilling position takes a long time. Using the Y axis allows efficient drilling on the end face. (SY type)

Machining Patterns

Differential cut

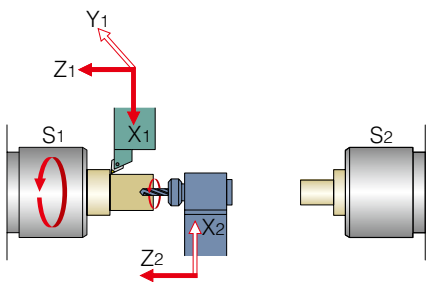

Center suport

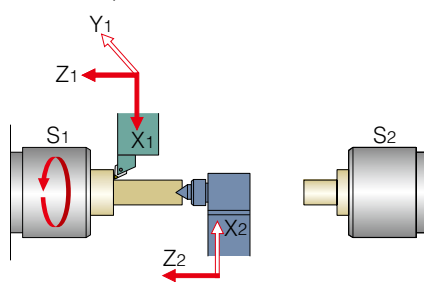

Drilling & tapping

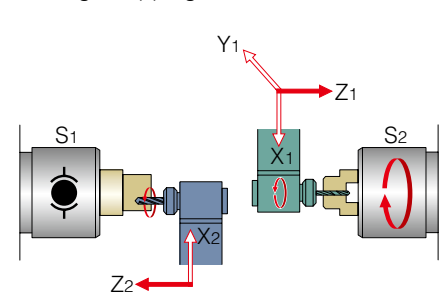

Long-shaft machining

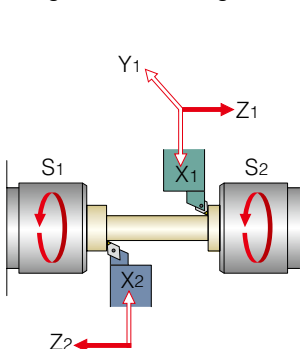

Balanced turning

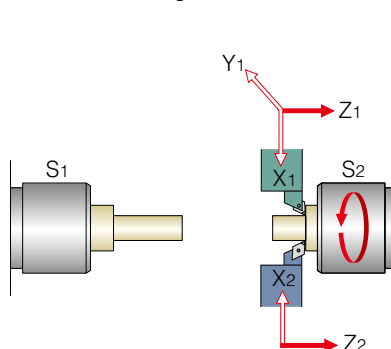

Simultaneous machining

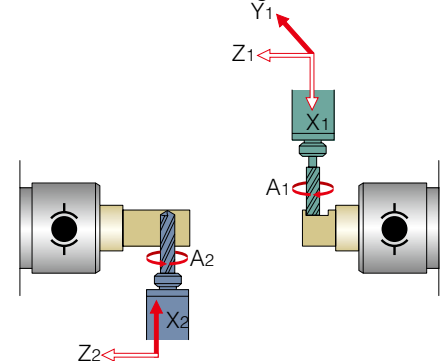

Tooling Area

BNE42
SY

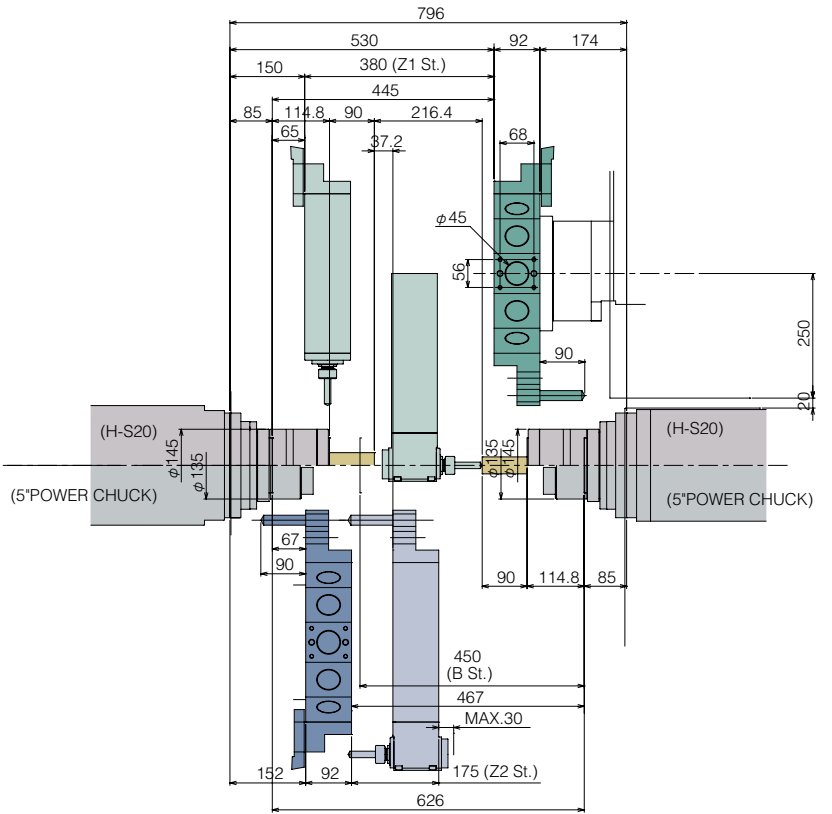
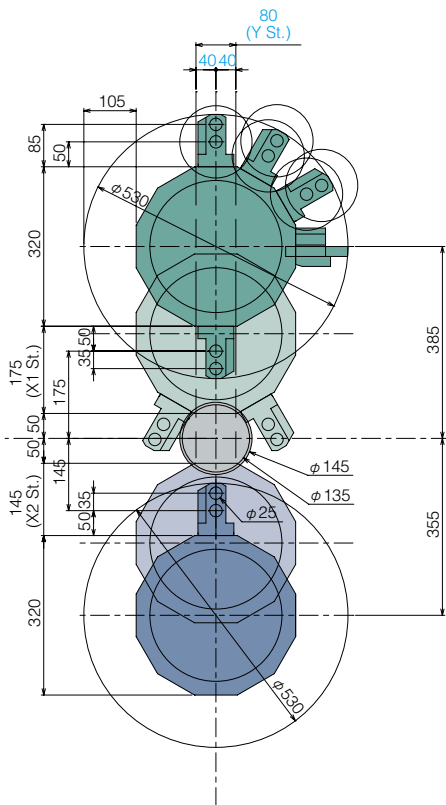

BNE51
SY

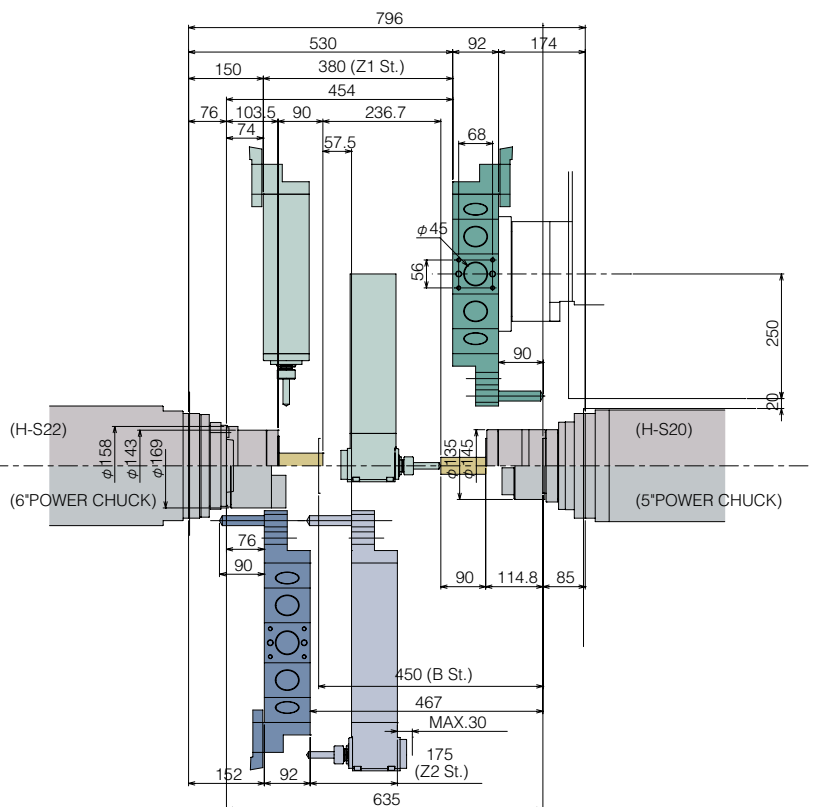
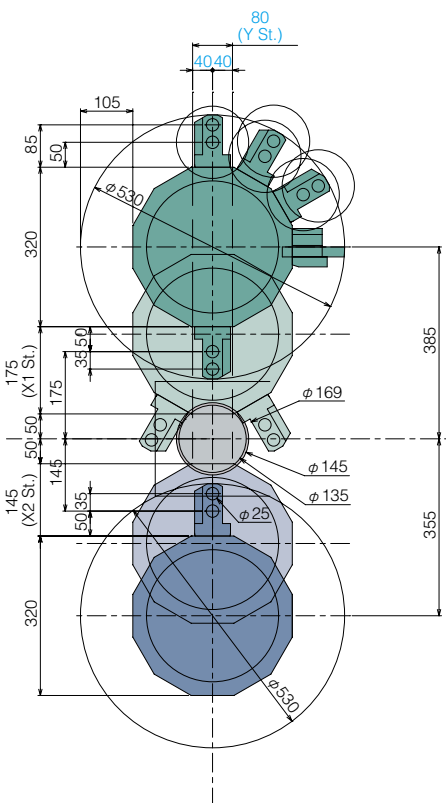

Tooling System

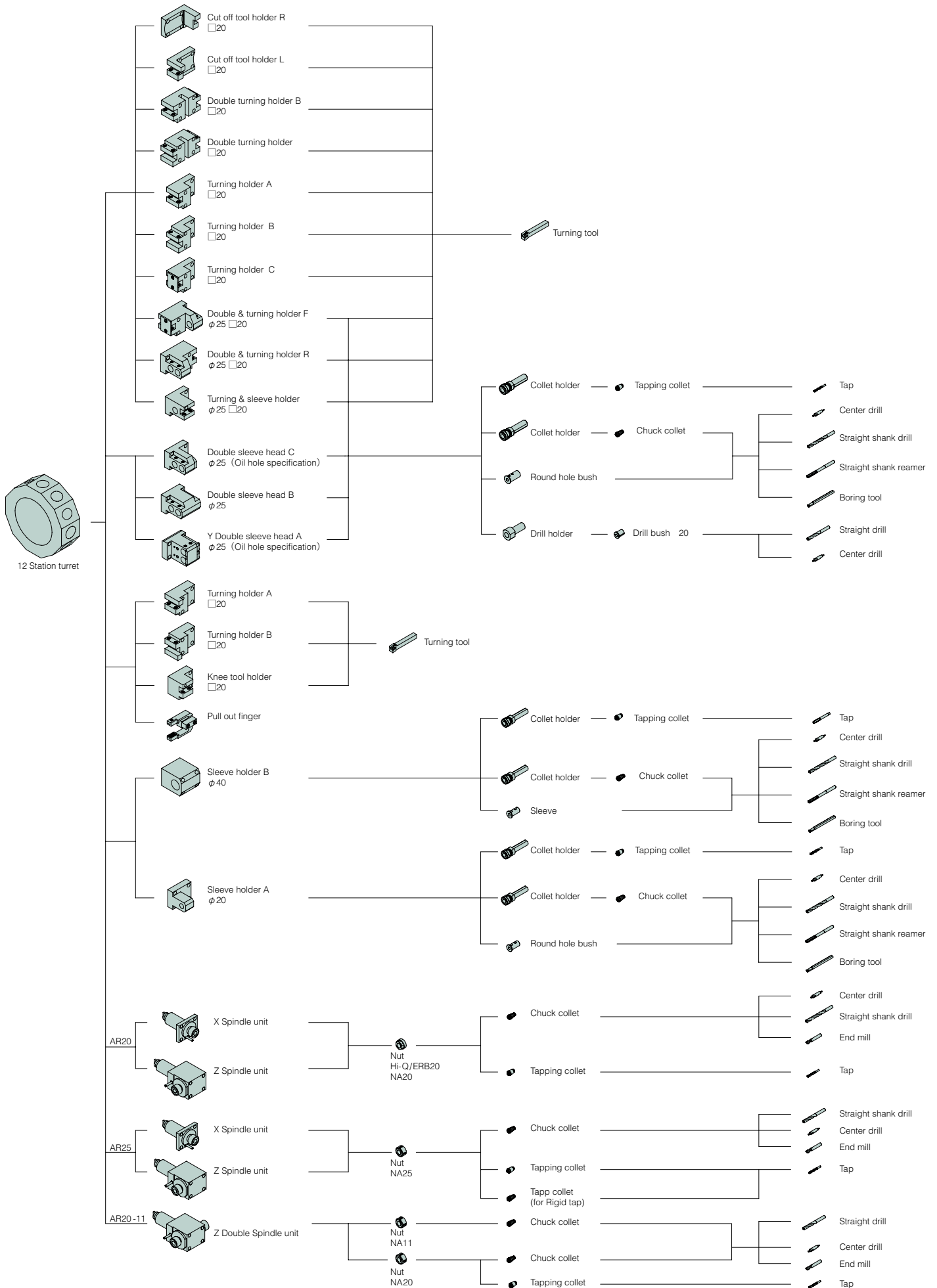

Accessories and Options

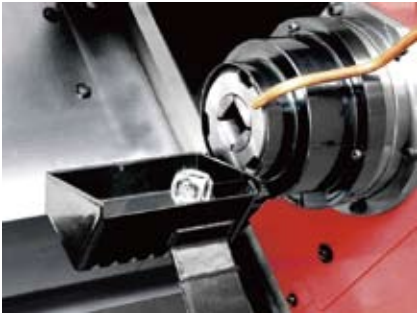

Part catcher

Catches finished workpieces without damaging them and transfers them to the part conveyor.



Revolving tool

Ensures high-power, stable milling at a torque of 20 Nm.



Automatic measuring device

Measures workpieces in the machine wirelessly using optical signal transmission.

Bar feeder

A range of barfeeders is available for short or long bars.



Chip conveyor

Ejects chips smoothly. Various types are available to suit the application.



External View

S

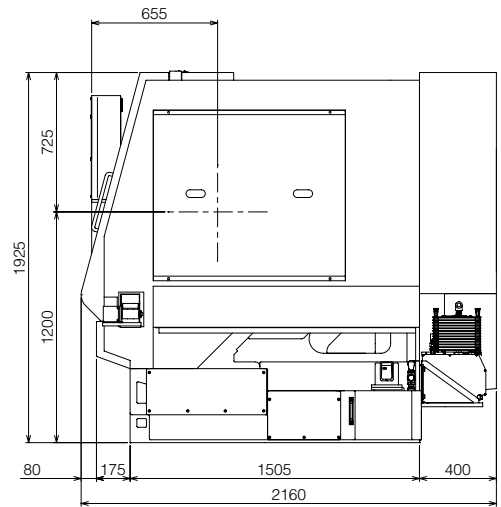
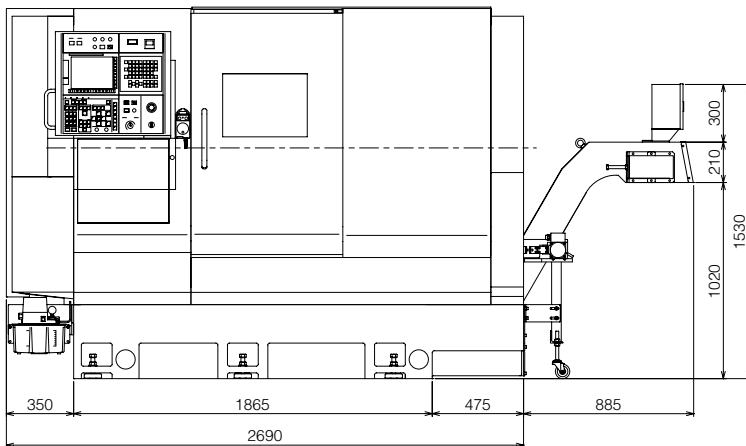

SY

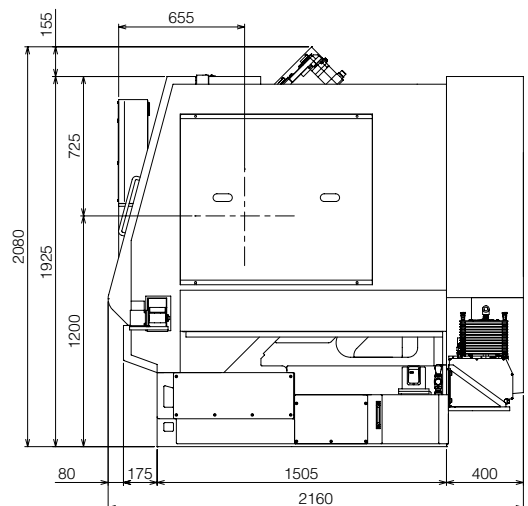
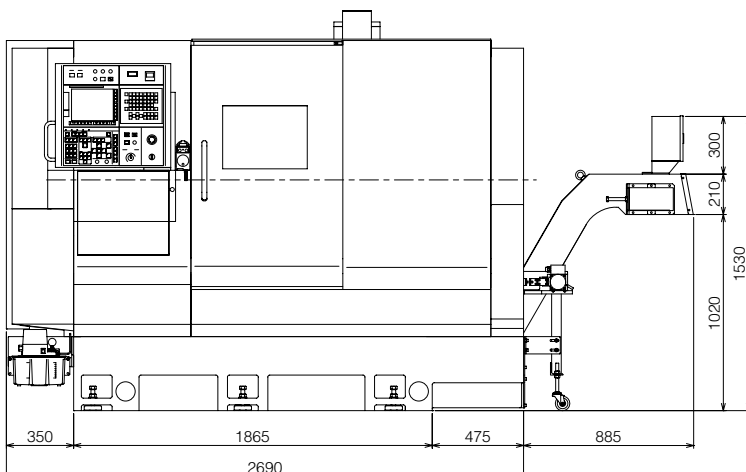

Support Screens



Machining data

Entering the machining length and position of the cut-off here makes it easier to measure geometry offsets and to mount tools.

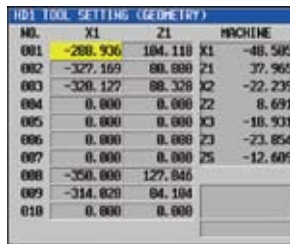

Tool setting

Used to measure geometry offsets. It can also be used for tool mounting support, to ensure that the overhang of all tools is fixed at a constant value.

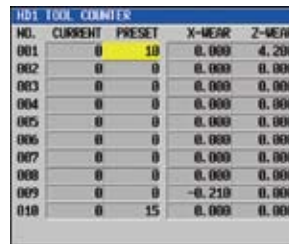

Tool counter

Informs you of the timing (count-up) for tool changes in accordance with the set tool counter stop value. You can also enter wear offsets.

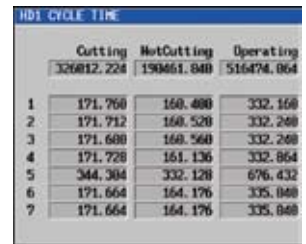

Cycle time

Allows you to measure the cutting time, non-cutting time and running time in each cycle.



Automatic running monitor (Spindle/ revolving tools)

Allows you to check the status of the spindle during automatic running.

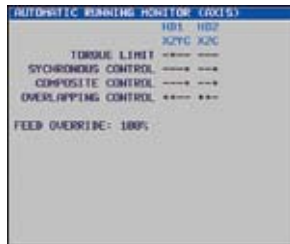

Automatic running monitor (axis)

Allows you to check the status of feed axes during automatic running.



Automatic running monitor (status)

Allows you to check the machining conditions during automatic running.



Start condition

Displays information on the start conditions for automatic running.

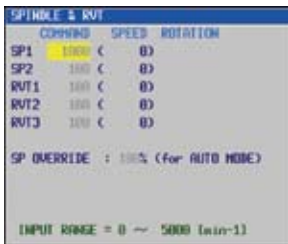

Spindle and revolving tool unit

Allows you to set the rotational speed (in manual operation) of the spindle and revolving tools, and to set the spindle override.

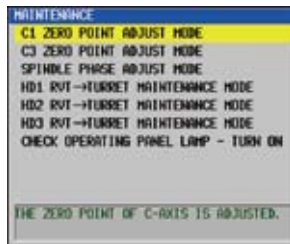

Maintenance

Used to turn the settings for maintenance ON and OFF.

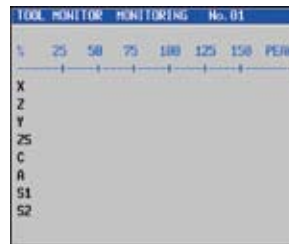

Tool monitor (option device)

Allows you to monitor tool wear and breakage by checking the current state of the machining and status of the cutting tools in terms of numerical values based on the sampling data.

NC Specifications

Model of NC	FS311-B 2 system
Axial control	HD1: X1, Z1, (Y1), C1, A1 HD2: X2, Z2, C2, A2, B2
Minimum setting unit	0.001mm, 0.001deg.
Interpolation functions	G01, G02, G03
Thread cutting	G32, G33, G92
Rapid feed override	0-100%
Feed rate override	0-150%
Feed rate per minute/Feed rate	G98/G99
program storage capacity	The sum total of 2 system:64Kbyte (160m)
Spindle function	S4 digit
Support function	M3digit
Constant surface speed control	G96
Tool function	Taabb (aa=Tool number and geometry, bb=Wear offset number)
Tool compensation number	32 pieces, 64 pieces(2 system)
Automatic operation	Automatic operation, MDI operation, Program number search, Sequence number search, Dry run, Single block, Optional stop (M01), Jog feed, Manual reference point return , Set up/ display function, Machine alarm message display, Self-diagnostic function,

	Periodical maintenance screen, Maintenance information screen, Help function,
	Actual speed display, Actual spindle speed and the T code display,
	Each group directory display.punch, Servo adjustment screen,
	Spindle adjustment screen, Hard & soft system configuration display.
Data input-and-output function	Memory card interface, USB memory interface.
Others	10.4" color LCD, Machine lock, Over travel, Stored stroke check, Chamfering ON/OFF, Backlash compensation, Synchronization / mixture control, Cs outline control, Spindle synchronous control, Superposition control, Polar coordinate interpolation, Optional block skip, Absolute command, Incremental command, A decimal point input, Coordinate system setup, Single form fixed cycle, The circle radius R command, Programmable data input.
Option	Cylindrical interpolation, Spindle rigid tap, Revolving tool rigid tap, Helical interpolation, Polygon turning, Work coordinate system, Inch / metric change, Tool nose radius compensation, Custom macro, Multiple repetitive cycles, Program storage capacity addition, Background editing, Tool nose radius compensation, Run hour and the number of parts display, Leader puncher interface, RS-232C port.

Machine specifications

Item		BNE-42S6	BNE-51S6	BNE-42SY6	BNE-51SY6	
Machining capacity						
Maximum work length		90mm				
Maximum bar diameter	SP1	42mm Dia.	51mm Dia.	42mm Dia.	51mm Dia.	
	SP2	42mm Dia.	42mm Dia.	42mm Dia.	42mm Dia.	
Spindle						
Number of spindles		2				
Spindle speed	SP1	6,000 min ⁻¹	5,000 min ⁻¹	6,000 min ⁻¹	5,000 min ⁻¹	
	SP2	5,000 min ⁻¹				
Spindle nose	SP1	Flat	A2-6	Flat	A2-6	
	SP2	Flat				
Draw tube Dia.	SP1	43 mm Dia.	52 mm Dia.	43 mm Dia.	52 mm Dia.	
	SP2	43 mm Dia.				
Type of collet chuck	SP1	H-S20/ DIN173E	H-S22/ DIN177E	H-S20/ DIN173E	H-S22/ DIN177E	
	SP2	H-S20/ DIN173E				
Power chuck size and type	SP1	5" (135 mm Dia.) Hydraulic	6" (169 mm Dia.)	5" (135 mm Dia.)	6" (169 mm Dia.)	
	SP2	5" (135 mm Dia.) Hydraulic				
Turret						
Number of turret		2				
Turret stations	HD1	12ST.				
	HD2	12ST.				
Shank size of square turning tool		20 mm Sq.				
Diameter of drill shank		25 mm Dia.				
Revolving tool						
Number of revolving tools		Max. 12+12				
Type of revolving tools		Single clutch				
Tool spindle speed range		Max. 6,000 min ⁻¹				
Feed rate						
Rapid feed rate	X1axis	18 m/ min				
	X2axis	16.2 m/ min				
	Z1axis	20 m/ min				
	Z2axis	18 m/ min				
	Y1axis		12 m/ min			
	Baxis	20 m/ min				
Slide stroke	X1axis	175 mm				
	X2axis	145 mm				
	Z1axis	380 mm				
	Z2axis	175 mm				
	Y1axis		±40 mm			
	Baxis	450mm				
Motors						
Spindle motor	SP1	15/ 11 kw (15min. /cont)				
	SP2	5.5/ 3.7 kw (15min. /cont)				
Revolving tool motor		2.2 kw 20 Nm				
Hydraulic operating motor		1.5 kw				
Lubricating motor		0.023 kw				
Coolant motor		0.25 kw				
High-pressure coolant motor		0.8/ 1.36 kw (50/ 60Hz)				
Turret index motor		0.75 kw				
Power supply						
Capacity		43 KVA	44 KVA	43 KVA	44 KVA	
Voltage		AC 200 V				
Air supply		0.5 Mpa				
Fuse		125 A				
Tank capacity						
Hydraulic oil tank capacity		10 L				
Lubricating oil tank capacity		4 L				
Coolant tank capacity		350 L				
Machine dimensions						
Machine height		1,925 mm			2,080 mm	
Floor space		W2,690xD2,160 mm				
Machine weight		7,600 kg	7,800 kg	7,600 kg	7,800 kg	
Optional accessories						
Spindle brake, Air blow, Work ejector, Automatic fire extinguisher, Automatic power shut-off, Chip box, Parts conveyor, Coolant level switch, High pressure coolant, Inner high pressure coolant & air blow, Tool setter, Parts Catcher, Parts Box, Collet chuck system, Chip conveyor, Total & preset counter, Oil mist collector, Signal tower, Filler tube, Spindle inner bushing, Bar feeder inner bushing, Cut-off confirmation, Parts carrier, Left over catcher, Drill checker.						

CITIZEN MACHINERY CO., LTD.

CITIZEN
Micro HumanTech

JAPAN	CITIZEN MACHINERY CO.,LTD. 4107-6 Miyota, Miyota-machi, Kitasaku-gun, Nagano-ken, 389-0206, JAPAN	TEL.81-267-32-5901	FAX.81-267-32-5908
SOUTH ASIA	CINCOM MIYANO ASIA SALES CO.,LTD. 1230 Rama 9 Road, Kwang Suanluang, Khet Suanuang, Bangkok 10250 THAILAND	TEL.66-23-745-226	FAX.66-23-745-228
KOREA	CINCOM MIYANO KOREA CO.,LTD. Room No.105 BYUCKSAN DIGITAL VALLEY I 212-16, Guro-3dong, Guro-gu, Seoul, KOREA	TEL.82-70-4337-1325	FAX.82-70-8220-8539
TAIWAN	CINCOM MIYANO TAIWAN CO.,LTD. 10Fl., No.174, Fuh Sing N. Rd., Taipei, TAIWAN	TEL.886-2-2715-0598	FAX.886-2-2718-3133
CHINA	CITIZEN (CHINA) PRECISION MACHINERY CO.,LTD. 10058, XINHUA ROAD OF ZHOUCUN, ZIBO, SHANDONG, P.R. CHINA	TEL.86-533-6150560	FAX.86-533-6161379
EUROPE-Germany	CITIZEN MACHINERY EUROPE GmbH Mettinger Strasse 11, D-73728 Esslingen, GERMANY	TEL.49-711-3906-100	FAX.49-711-3906-106
EUROPE-UK	CITIZEN MACHINERY UK LTD 1 Park Avenue, Bushey, WD23 2DA, UK	TEL.44-1923-691500	FAX.44-1923-691599
AMERICA	MARUBENI CITIZEN-CINCOM INC. 40 Boroline Road Allendale, NJ 07401, U.S.A.	TEL.1-201-818-0100	FAX.1-201-818-1877

URL:<http://cmj.citizen.co.jp/>

All specifications are subject to change without prior notice. This product is an export control item subject to the foreign exchange and foreign trade act. Thus, before exporting this product, or taking it overseas, contact your CITIZEN machine dealer. Please inform your CITIZEN machine dealer in advance of your intention to re-sell, export or relocate this product. For the avoidance of doubt products includes whole or part, replica or copy, technologies and software. In the event of export, proof of approval to export by government or regulatory authority must be evidenced to CITIZEN. You can operate the machines after the confirmation of CITIZEN. CITIZEN is a registered trademark of Citizen Holdings Co., Japan.