

F2000EX EASY	ATA 32 – LANDING GEAR AND BRAKING SYSTEM	02-32-00
CODDE 1		PAGE 1 / 2
DGT94085		ISSUE 3

02-32 ATA 32 – LANDING GEAR AND BRAKING SYSTEM

02-32-00 TABLE OF CONTENTS

02-32-05 GENERAL

- Introduction
- Sources
- Landing gear location

02-32-10 DESCRIPTION

- Landing gear
- Brakes
- Distribution

02-32-15 CONTROL AND INDICATION

- Control
- Indication
- Erroneous indications

02-32-20 SYSTEM PROTECTION

- Introduction
- Circuit breakers
- Wheels

02-32-25 NORMAL OPERATION

- Introduction
- GROUND operation
- IN-FLIGHT operation

02-32-30 ABNORMAL OPERATION

- Introduction
- Gear in transit with too long extension time
- Total loss of hydraulic power
- CAS messages

02-32-00	ATA 32 – LANDING GEAR AND BRAKING SYSTEM TABLE OF CONTENTS	F2000EX EASY
PAGE 2 / 2		CODDE 1
ISSUE 3		DGT94085

INTENTIONALLY LEFT BLANK

F2000EX EASY	ATA 32 – LANDING GEAR AND BRAKING SYSTEM GENERAL	02-32-05
CODDE 1		PAGE 1 / 4
DGT94085		ISSUE 3

INTRODUCTION

The Falcon 2000EX EASy has a retractable tricycle landing gear consisting of two dual tire main gears and one dual tire nose gear.

Each landing gear strut is equipped with dual radial tires.

Each main landing gear wheel houses a carbon brake assembly.

02-32-05	ATA 32 – LANDING GEAR AND BRAKING SYSTEM GENERAL	F2000EX EASY
PAGE 2 / 4		CODDE 1
ISSUE 3		DGT94085

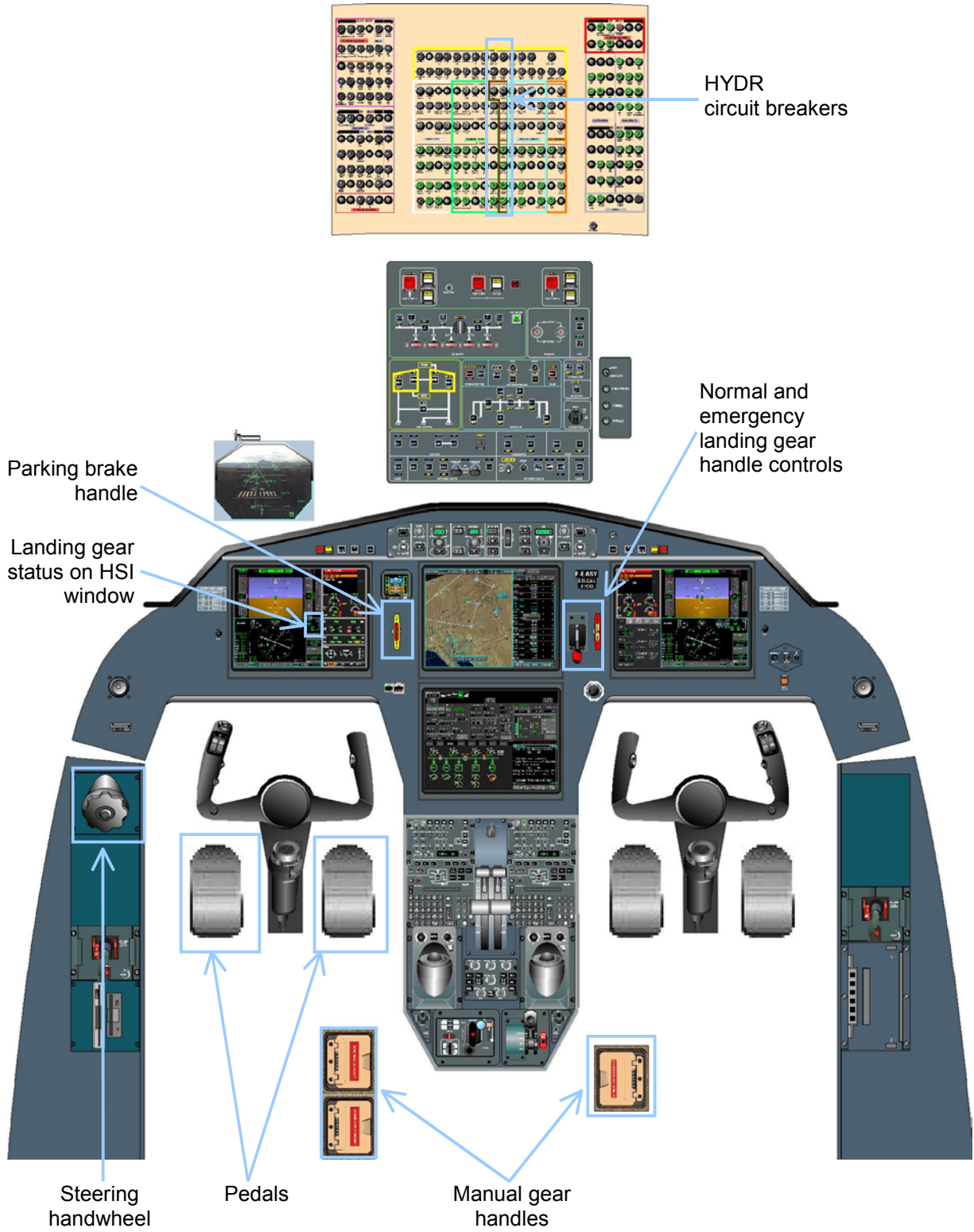

FIGURE 02-32-05-00 FLIGHT DECK OVERVIEW

F2000EX EASY	ATA 32 – LANDING GEAR AND BRAKING SYSTEM	02-32-05
CODDE 1		PAGE 3 / 4
DGT94085		GENERAL

SOURCES

In normal operation, landing gear is electrically controlled from the pilot station and hydraulically actuated. In emergency mode, landing gear is actuated only by hydraulic power. In free fall mode, the landing gear extends by gravity.

Braking system control and interfaces are provided through the brake pedals and parking brake handle.

Normal braking system needs hydraulic and electrical power, whereas parking brake only needs hydraulic power.

ELECTRICAL	HYDRAULIC
A1 bus	hydraulic reservoirs 1 and 2 parking brake accumulator (supplied by HYD 2) for parking and emergency braking.
A2 bus	
B1 bus	
B2 bus	
ESS bus	

LANDING GEAR LOCATION

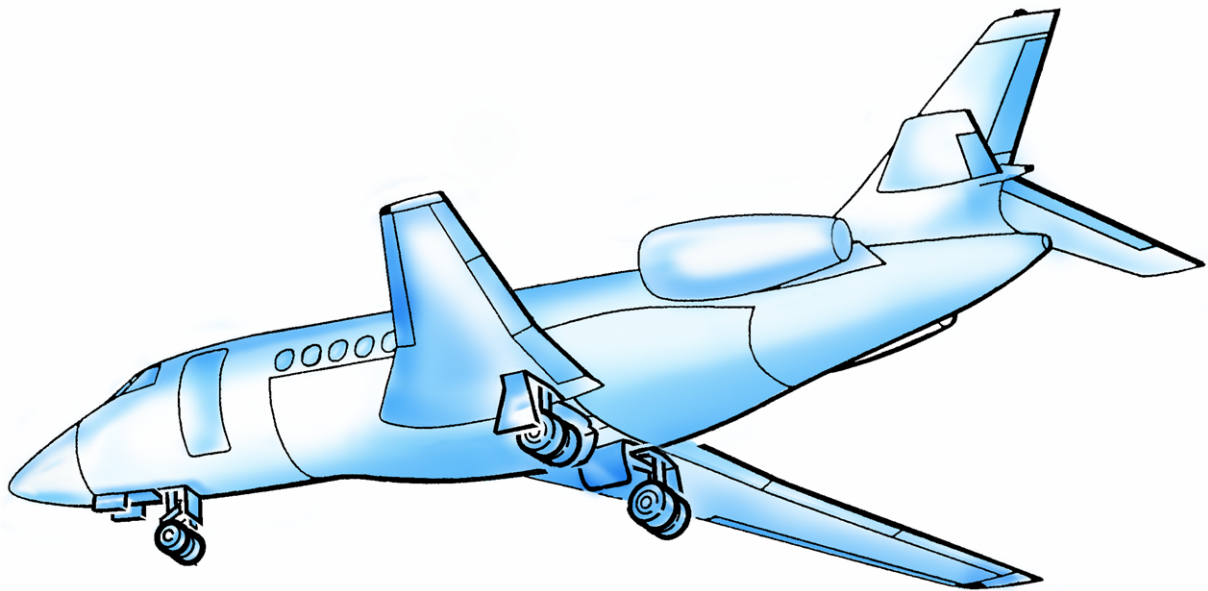

FIGURE 02-32-05-01 LANDING GEAR OVERVIEW DIAGRAM

02-32-05	ATA 32 – LANDING GEAR AND BRAKING SYSTEM GENERAL	F2000EX EASY
PAGE 4 / 4		CODDE 1
ISSUE 3		DGT94085

INTENTIONALLY LEFT BLANK

F2000EX EASY	ATA 32 – LANDING GEAR AND BRAKING SYSTEM DESCRIPTION	02-32-10
CODDE 1		PAGE 1 / 12
DGT94085		ISSUE 3

LANDING GEAR

NOSEWHEEL STEERING

The steering handwheel is located on the left console. When manually rotated, the handwheel actuates a control potentiometer to provide steering signals through the Braking and Steering Control Unit (BSCU) to the servo-valve on the steering assembly. The handwheel must be depressed to unlock and energize the steering selector valve. The nosewheels are steered from 0 to 60° and are equipped with a centering system allowing the gear centering for retraction and extension.

Nosewheel steering system uses HYD 1 system.

When the hydraulic power is not supplied to the steering system, the nosewheel shimmy effect is damped by the anti-shimmy system.

When the nose gear is retracted, the hydraulic pressure in the steering system drops to zero (no more control).

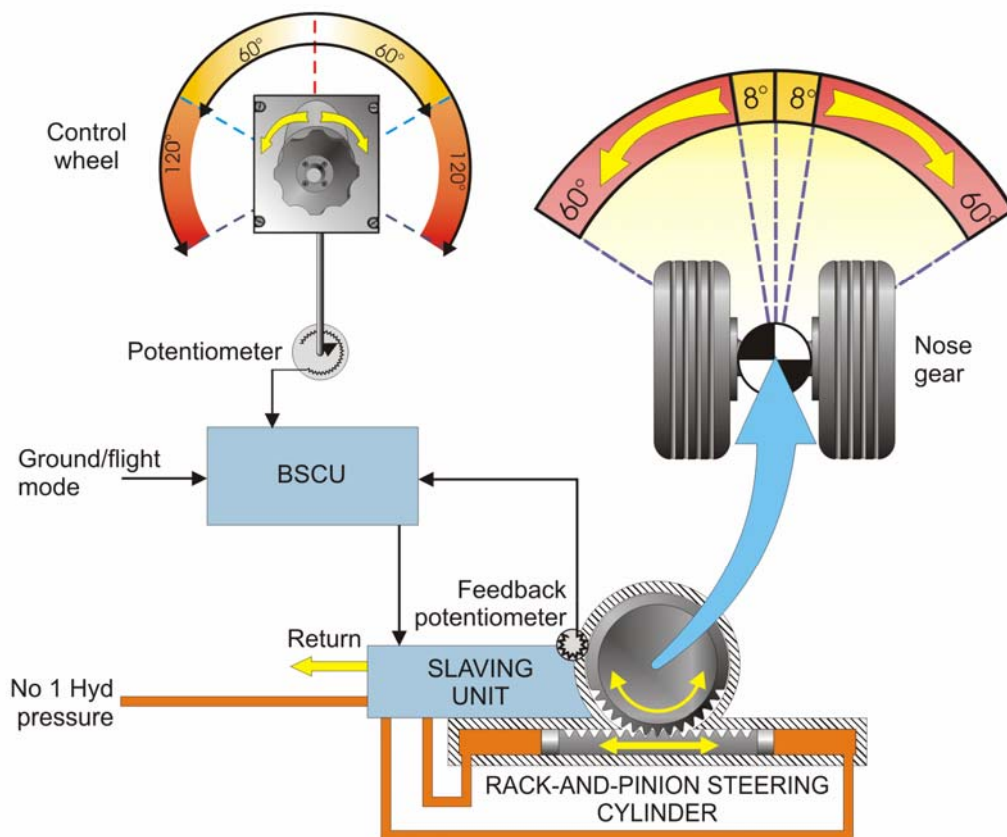

FIGURE 02-32-10-00 STEERING SYSTEM DIAGRAM

02-32-10	ATA 32 – LANDING GEAR AND BRAKING SYSTEM	F2000EX EASY
PAGE 2 / 12		CODDE 1
ISSUE 3		DESCRIPTION

MAIN GEAR

Each main landing gear primarily consists of a shock strut barrel housing a shock absorber (lower unit). The shock absorber is equipped with the axle, wheels and brake assemblies and is connected to the barrel with scissor links.

The design is optimized for maximum thermal performance and includes a deep draw conical wheel web for maximum brake energy.

The outboard end of each wheel hub is equipped with a drive cap carrying a drive blade which engages and drives the braking control system tachometer which is housed within the hollow axle.

Each main gear also features two flight/ground proximity sensors and two wheel speed transducers (dual channels) for the brake anti-skid system, one driven by each main wheel. When extended, the main gear is downlocked by an integral lock in the gear actuator and by continuously applied hydraulic pressure. When retracted, the gear is uplocked by mechanical lock units that are mechanically locked and hydraulically unlocked in the normal and emergency operating modes and mechanically unlocked in the free fall extension mode.

Each main gear is enclosed at retraction with a main door and a fairing door.

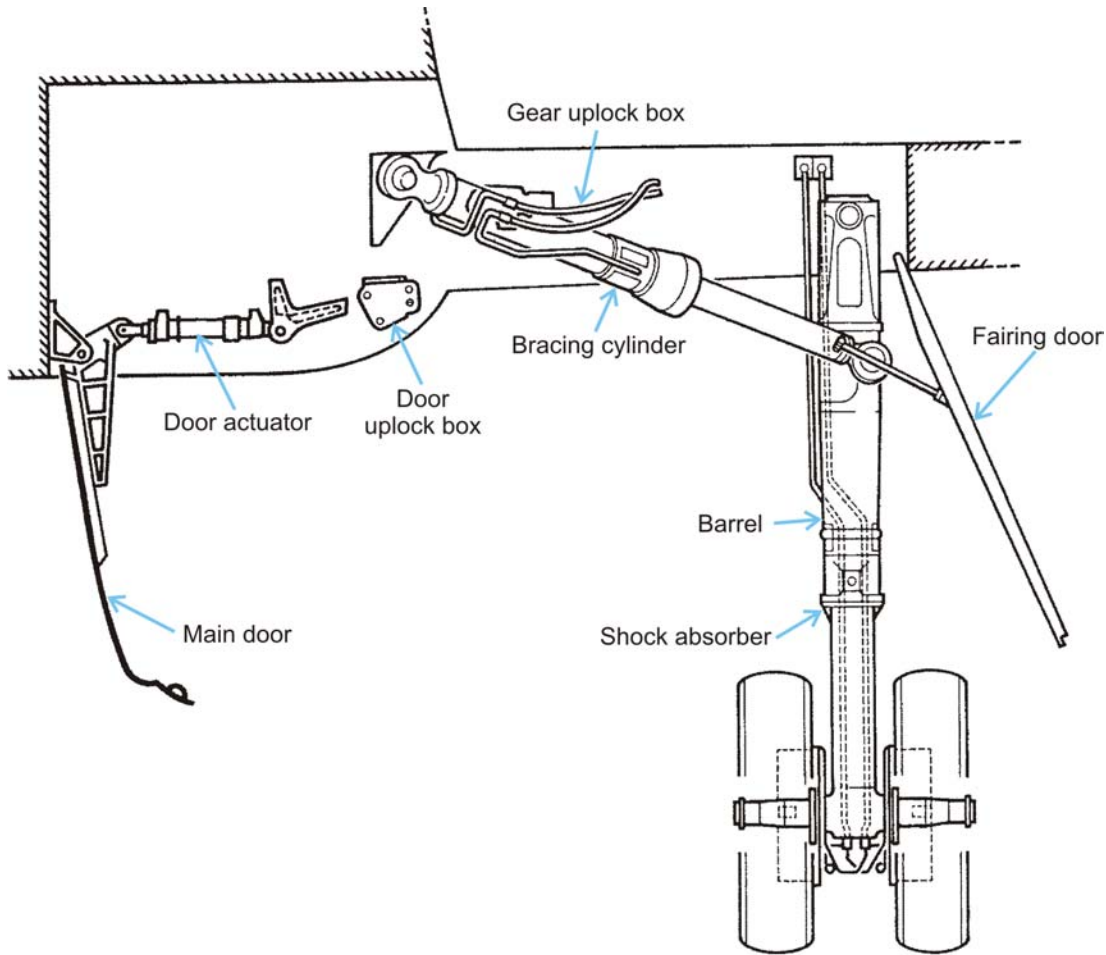

FIGURE 02-32-10-01 MAIN LANDING GEAR DESCRIPTION DIAGRAM

F2000EX EASY	ATA 32 – LANDING GEAR AND BRAKING SYSTEM	02-32-10
CODDE 1		PAGE 3 / 12
DGT94085		ISSUE 3

DESCRIPTION

MAIN GEAR TIRES

This airplane is equipped with tubeless radial tires.

NOSE GEAR

The nose gear includes an outer shock strut barrel housing a shock absorber. A rotating inner barrel is controlled by the steering mechanism.

The inner barrel and shock absorber are connected with scissor links. A hydraulically-actuated rack-and-pinion steering actuator within the inner barrel provides steering motion.

Four nose gear doors enclose the nose gear at retraction. The upper aft door is mechanically connected to the landing gear and to the airplane structure. The lower aft door is connected to the scissor links. Both doors move to enclose the rear area of the gear at retraction.

The two forward doors are mechanically actuated by rollers on the torque link lower arm, closing the doors at retraction.

The nosewheels must be equipped with chine tires.

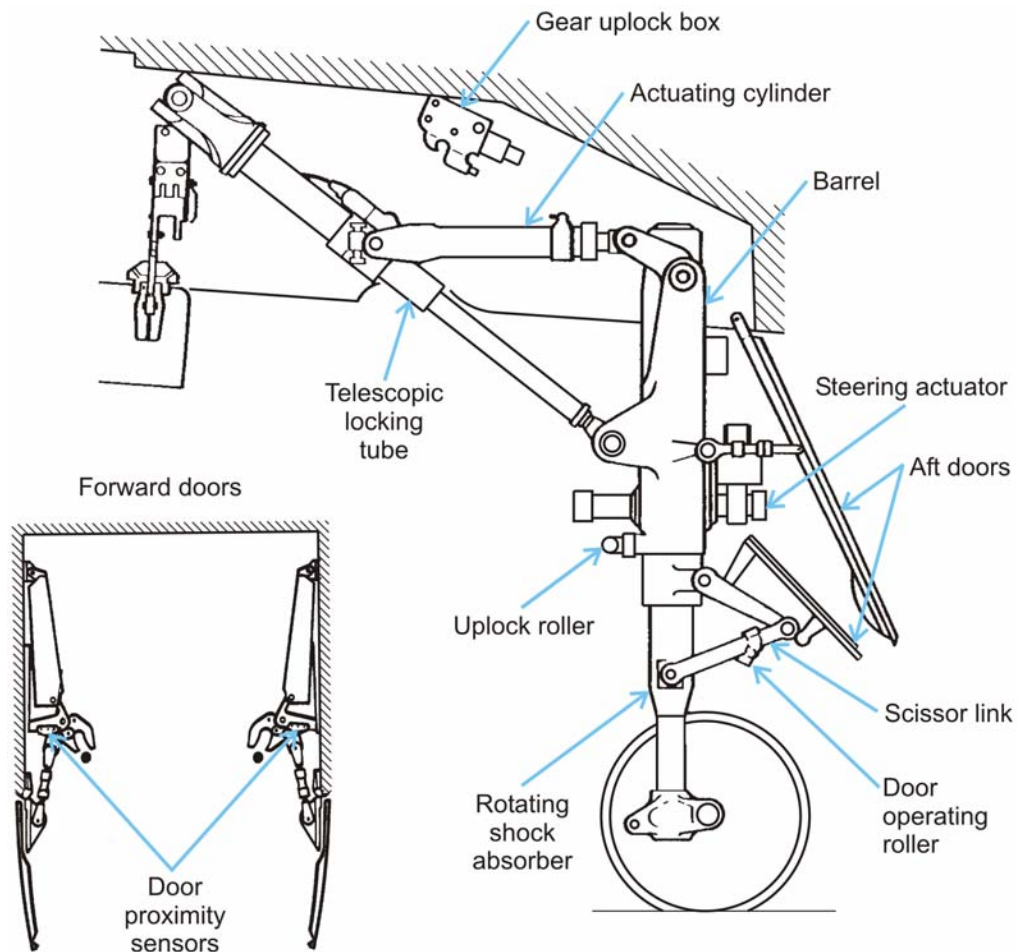

FIGURE 02-32-10-02 NOSE GEAR DESCRIPTION DIAGRAM

02-32-10	ATA 32 – LANDING GEAR AND BRAKING SYSTEM DESCRIPTION	F2000EX EASY
PAGE 4 / 12		CODDE 1
ISSUE 3		DGT94085

NORMAL GEAR OPERATION SEQUENCE

Landing gear extension and retraction sequence is controlled by proximity sensors on the door unlock units and on the main gear door actuators.

NOTE

The doors do not operate unless the gear is fully unlocked or downlocked.

The sequence of gear operation is:

- main doors open,
- gear extends or retracts,
- main doors close.

Proximity sensor status changes after the completion of an operation and the next operation is initiated.

The nose gear doors are not sequenced; they are mechanically actuated by nose gear movement.

During retraction sequence, the BSCU applies brake pressure to stop the rotation prior to main gear retraction and before the wheels enter the wheel well.

F2000EX EASY	ATA 32 – LANDING GEAR AND BRAKING SYSTEM DESCRIPTION	02-32-10
CODDE 1		PAGE 5 / 12
DGT94085		ISSUE 3

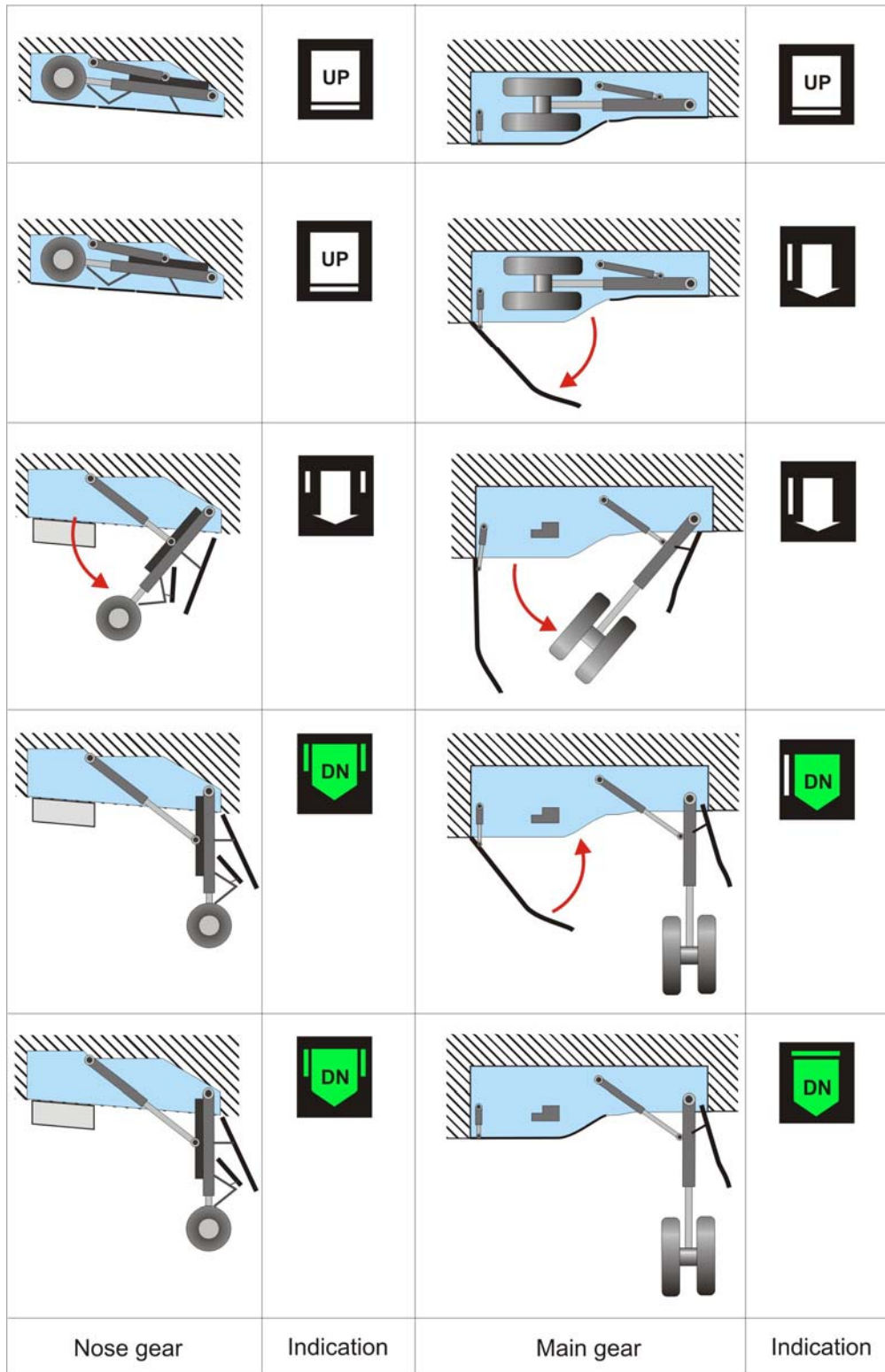

FIGURE 02-32-10-03 LANDING GEAR EXTENSION DIAGRAM

02-32-10	ATA 32 – LANDING GEAR AND BRAKING SYSTEM	F2000EX EASY
PAGE 6 / 12		CODDE 1
ISSUE 3		DGT94085
DESCRIPTION		

EMERGENCY CONTROL SYSTEM

The emergency control system uses pressure from the same hydraulic system and is provided as a means to extend the gear in case the normal control system has failed.

The system consists of a mechanical control which operates slide valves to connect simultaneously the normal control system pressure lines to:

- door latches,
- gear uplocks,
- actuators.

Although there is no sequencing, no wheel jamming will occur in case a tire comes in contact with a door.

When using emergency system, the doors stay open after full extension of the gear.

FREE FALL CONTROL SYSTEM

The free fall control system allows extension of the gear by gravity if the hydraulic system is inoperative. Extension takes place as follows:

- actuate the emergency gear handle to position the slide valves so as to allow fluid in the door and gear actuators to be directed to return lines,
- release the door latches and gear uplocks one at a time by pulling corresponding handles located on either side of the cockpit pedestal.

There is no sequence, the gears extend by gravity, and correct locking is achieved with the help of aerodynamic loads.

BRAKES

Each brake consists of a brake housing assembly (hydraulic supply) and a carbon composite hot section (heat sink). It is a three pair carbon brake assembly. The brakes are equipped with two sets of pistons working at the same time.

The pilot pedals act on two dual channel transducers; the copilot pedals are mechanically linked to pilot pedals.

F2000EX EASY	ATA 32 – LANDING GEAR AND BRAKING SYSTEM	02-32-10
CODDE 1		PAGE 7 / 12
DGT94085		ISSUE 3

BRAKING SYSTEM

General

The basic task of the Brake Control System is:

- to control hydraulic pressure on the aircraft brakes as a function of brake pedal position,
- to provide anti-skid protection to prevent deep tire skidding and minimize stopping distance.

The braking system provides two modes of operation:

- a normal mode, controlled by the brake pedals, which provides differential and progressive braking with anti-skid capability. This mode uses two laws: an acceleration feedback law and a pressure feedback law.
- An emergency mode, controlled by the park brake handle, which provides non-differential braking without anti-skid function.

Principle

The braking system uses brake pedal position transducers (electrical signals: “braking-by-wire”) and main wheel speeds supplied by tachometer generators.

The brake pedal position is converted in a deceleration rate, which is compared with the wheel deceleration rate to provide a brake pressure command. If a wheel is detected by the BSCU as entering a skid condition, brake pressure is released on this wheel to avoid the skid condition while maintaining maximum commanded brake pressure. The anti-skid system cannot be controlled by the pilot.

Normal braking is provided by two channels which are electrically and hydraulically independent:

- channel 1 is controlled by BSCU 1, powered by the essential electrical bus (ENG No 1 generator and battery), and uses hydraulic system No 1,
- channel 2 is controlled by BSCU 2, powered by the RH electrical bus (ENG No 2 generator) in parallel with LH electrical bus, and uses hydraulic system No 2.

In case of failure of one of the two channels (due to either an electrical or a hydraulic failure), the other system remains available and can provide braking and anti-skid functions.

If a failure occurs in both systems, the park brake handle can be used to stop the aircraft.

Even in case of total loss of hydraulic pressure, the back-up braking system can be used because it is fitted with a dedicated accumulator. When the accumulator pressure is less than 1,900 psi, a **BRAKE ACCU** CAS message is activated and the park brake can be applied at least six times.

The back-up system does not provide anti-skid protection.

02-32-10	ATA 32 – LANDING GEAR AND BRAKING SYSTEM	F2000EX EASY
PAGE 8 / 12		CODDE 1
ISSUE 3		DGT94085
DESCRIPTION		

Automatic airbrake extension

The braking system also provides signals for automatic airbrake activation.

The automatic mode commands automatic extension of airbrakes at touchdown and during rejected take-off. This feature can be disarmed by the crew if necessary. The purpose of this automatic function is to:

- enhance overall braking action during landing or rejected take-off,
- cancel potential bounces after touchdown.

The operation of this automatic mode depends on landing and rejected take-off logic elaborated by BSCU computers.

Brake temperature

BSCU computers monitor the individual wheel brake temperatures.

NOTE

The brake temperature is measured from 0 to 1,100°C. The accuracy of the measurement is of $\pm 25^\circ\text{C}$ below 665°C and of $\pm 50^\circ\text{C}$ from 665°C to 1,100°C.

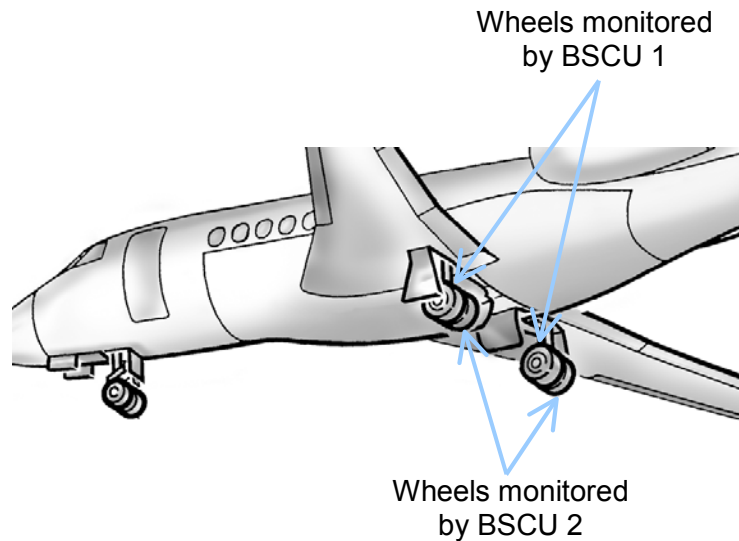

FIGURE 02-32-10-04 TEMPERATURE MONITORING

F2000EX EASY	ATA 32 – LANDING GEAR AND BRAKING SYSTEM DESCRIPTION	02-32-10
CODDE 1		PAGE 9 / 12
DGT94085		ISSUE 3

ANTI-SKID CONTROL

General

Anti-skid control modulates brake pressure as required to prevent deep tire skidding and achieve maximum braking effectiveness. The Brake Control System (BCS) is tuned to attenuate signals occurring at resonating frequencies of the landing gear.

Control of wheel skid is done by the BSCU with inputs from:

- wheel speed tachometers (one per wheel, i.e. two per leg),
- IRS (which compute airplane ground speed and deceleration).

The difference between these two values gives the wheel skid.

As a wheel begins to enter a skid condition, the BSCU commands the brake control valve to limit brake pressure as necessary to:

- avoid skidding,
- maintain maximum commanded braking.

If the wheel does not skid, there is no brake release order and the brake pressure corresponds to the pedal position. If the wheel skids but is not blocked, a brake release order is computed. If the wheel is blocked, a total brake release order is sent.

Tire burst

The braking system is protected against tire burst and tachometer failure.

When a tire bursts, the corresponding wheel is no longer in contact with the ground; its speed is thus considered as nil. A brake release order is then sent to the L/G leg resulting in a complete loss of braking efficiency on the relevant L/G.

After 0.4 sec of complete brake release on a wheel (or in the event of tachometer failure) the brake release order relative to the burst tire is gradually suppressed. The system only takes into account the remaining wheel speed.

Aquaplaning safety

If the wheel speed does not increase after touchdown, the aquaplaning safety mode inhibits braking.

02-32-10	ATA 32 – LANDING GEAR AND BRAKING SYSTEM DESCRIPTION	F2000EX EASY
PAGE 10 / 12		CODDE 1
ISSUE 3		DGT94085

PARKING BRAKE

The parking brake is designed to:

- keep the airplane at rest for parking purposes (handle in intermediate position),
- slow down and stop the airplane in case of normal brake failure,
- keep the airplane at rest with one engine at maximum thrust and the other at idle thrust (handle in fully pulled position).

It is supplied by HYD 2 system and is equipped with a dedicated accumulator.

The braking pressure is progressive and depends on handle position. It is not differential and does not include any anti-skid device.

NOTE

The ground run-up with two engines at full power is held by the normal braking system (pedals), with the two systems operating.

FAULT DETECTION AND STORAGE

Braking system interfaces with the avionics system to provide fault detection and maintenance diagnostic data transfer.

Each BSCU has the capability to detect internal and external faults related to the brake control system. In addition, each BSCU transmits maintenance data.

A check valve permits the system to avoid false failure detection due to pressure surges, especially during landing gear extension/retraction.

F2000EX EASY	ATA 32 – LANDING GEAR AND BRAKING SYSTEM DESCRIPTION	02-32-10
CODDE 1		PAGE 11 / 12
DGT94085		ISSUE 3

DISTRIBUTION

The landing gear is hydraulically actuated. There are two hydraulic systems.

➤ *for more information, refer to CODDE 1 / Chapter 02 / ATA 29.*

HYD 1 system supplies:

- No 1 brake system,
- landing gear and doors,
- nose wheel steering.

HYD 2 system supplies:

- No 2 brake system,
- parking brake,
- airbrakes.

The landing gear carbon disk brakes are powered independently by the two hydraulic systems.

HYD 2 system provides back-up braking with an accumulator for emergency braking.

Both braking systems incorporate an anti-skid system.

02-32-10	ATA 32 – LANDING GEAR AND BRAKING SYSTEM DESCRIPTION	F2000EX EASY
PAGE 12 / 12		CODDE 1
ISSUE 3		DGT94085

INTENTIONNALLY LEFT BLANK

F2000EX EASY	ATA 32 – LANDING GEAR AND BRAKING SYSTEM	02-32-15
CODDE 1		PAGE 1 / 8
DGT94085		ISSUE 3

CONTROL

FRONT PANEL

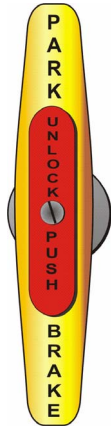

park brake handle

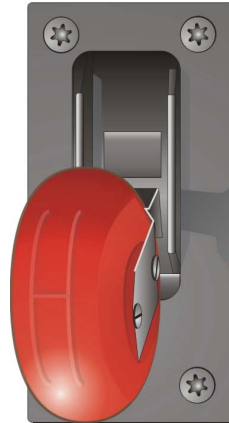

gear handle



emer pull gear handle

FIGURE 02-32-15-00 FRONT PANEL CONTROLS

FLOOR

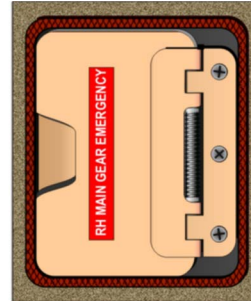
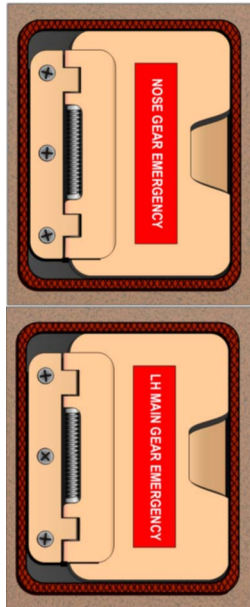



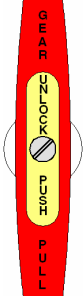
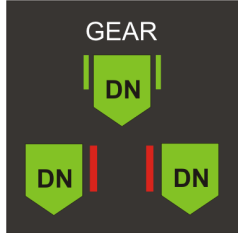
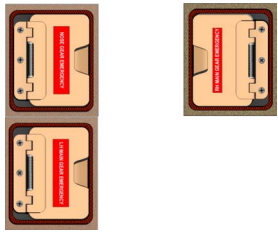
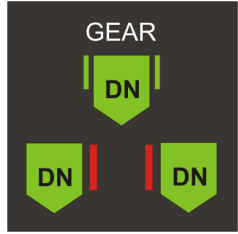

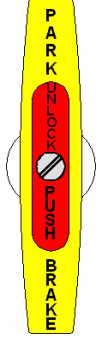
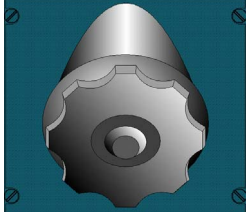

FIGURE 02-32-15-01 MANUALLY-ACTUATED GEAR HANDLES

CONTROL	FUNCTION	TO ACTIVATE	SYNOPTIC
	<p>Controls extension and retraction of the landing gear</p> <p>The handle is equipped with a red blinker to indicate abnormal gear status in the following conditions:</p> <ul style="list-style-type: none"> - at least one gear not downlocked - both throttles in low thrust position - speed below threshold (*) - altitude < 500 ft and radar altimeter valid, or radar altimeter invalid, <div style="border: 1px solid black; padding: 5px; text-align: center;"> <p>NOTE</p> <p>In this case, aural warning "GEAR" is activated.</p> </div> <p>or</p> <ul style="list-style-type: none"> - after a 20-sec delay, the landing gear position does not comply with control handle position <p>(*) Speed threshold:</p> <ul style="list-style-type: none"> - 150 kt decreasing speed - 155 kt increasing speed 	 <p style="text-align: center;">UP</p>	<div style="background-color: black; color: white; padding: 10px; text-align: center;"> <p>GEAR</p> <p style="font-size: 2em;">UP</p> <p style="font-size: 1.5em;">UP UP</p> </div> <p>Displayed for 10 sec after up-lock, then</p> <div style="background-color: black; color: white; padding: 10px; text-align: center;"> <p>GEAR</p> <p style="font-size: 1.5em;">UP</p> </div> <p>until airplane reaches:</p> <ul style="list-style-type: none"> - 18,500 ft climbing, - 18,000 ft descending <div style="background-color: black; color: white; padding: 10px; text-align: center;"> <p style="font-size: 2em;">GEAR</p> <p style="font-size: 1.5em;">DN DN</p> </div> <p>Displayed above 18,000 / 18,500 ft</p>
		 <p style="text-align: center;">DOWN</p>	<div style="background-color: black; color: white; padding: 10px; text-align: center;"> <p>GEAR</p> <p style="font-size: 1.5em;">DN DN</p> </div>

F2000EX EASY	ATA 32 – LANDING GEAR AND BRAKING SYSTEM	02-32-15
CODDE 1		PAGE 3 / 8
DGT94085		ISSUE 3

CONTROL	FUNCTION	TO ACTIVATE	SYNOPTIC
	Actuates emergency gear extension. No sequencing is performed and the doors remain open. For gear extension only	To activate, push the yellow part to unlock then pull the handle.	
	Provide manual unlocking of the gears and the main gear inner doors for free fall emergency extension (gravity extension)	To activate, raise the cover and pull the handle.	
	<ul style="list-style-type: none"> - The pilot pedals send the pilot braking order to the braking system - It is common to the two braking channels 		No associated synoptic
	<p>Mechanically activates braking through HYD 2 system</p> <p>There are two locking detents:</p> <ul style="list-style-type: none"> - one for park braking and stand-by brake - one for run-up (on one engine) 	<ul style="list-style-type: none"> - To set to first detent, pull the handle to the stop - To set to second detent, push the unlock button and pull the handle fully 	No associated synoptic.
	Actuates a control potentiometer to provide steering signals through the BSCU to the torque motor on the steering assembly	To activate the steering before turning, the hand-wheel needs to be pushed in.	No associated synoptic

02-32-15	ATA 32 – LANDING GEAR AND BRAKING SYSTEM CONTROL AND INDICATION	F2000EX EASY
PAGE 4 / 8		CODDE 1
ISSUE 3		DGT94085

INDICATION

Gear and configuration indications can be found on PDU, in the right upper side of the HSI window.



FIGURE 02-32-15-02 HSI WINDOW

NORMAL STATUS

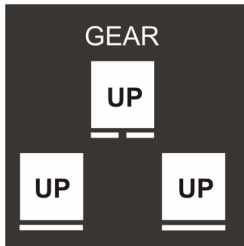

Gear up and locked.
Gear doors closed.

Displayed for 10 sec after retraction

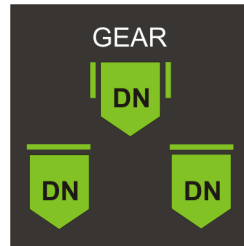

Gear down and locked.

Left and right main gear doors are closed.

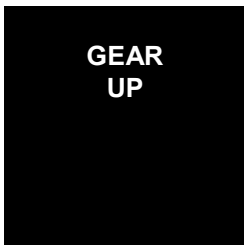

Gear up and locked.
Gear doors closed.

Displayed under 18,000 ft.

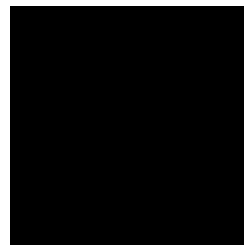

Gear up and locked.
Gear doors closed.

Displayed above 18,000 ft

F2000EX EASY	ATA 32 – LANDING GEAR AND BRAKING SYSTEM CONTROL AND INDICATION	02-32-15
CODDE 1		PAGE 5 / 8
DGT94085		ISSUE 3

When all gears are up for more than 10 sec, a GEAR UP annunciation is displayed and the gear symbol is removed.

The GEAR UP indication is no longer displayed when the altitude on the pilot flying side is above 18,500 ft if climbing and above 18,000 ft if descending.

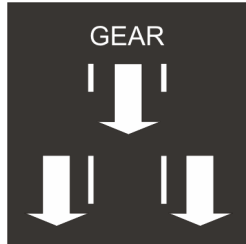

Gear handle selection is gear down.
Gears are unlocked and in transition.
Gear doors are open.

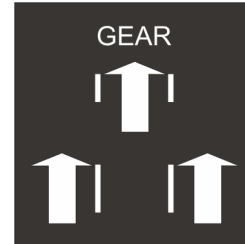

Gear handle selection is gear up.
Gears are unlocked and in transition.
Gear doors are open.

ABNORMAL STATUS

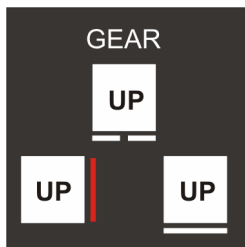

Gears are up and locked.
Left main gear door remains open.

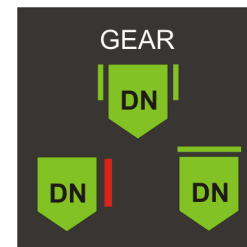

Gears are down and locked.
Left main gear door remains open.

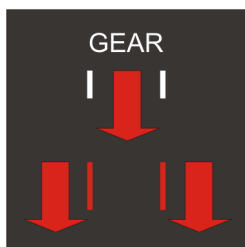

Gear handle selection is gear down.
20 sec have elapsed and gears are not indicated down and locked.

In this case, gear handle light blinks and **LANDING GEAR** is displayed.

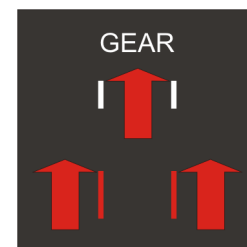

Gear handle selection is gear up.
20 sec have elapsed and gears are not indicated up and locked.

In this case, gear handle light blinks and **LANDING GEAR NOT UP** is displayed.

02-32-15	ATA 32 – LANDING GEAR AND BRAKING SYSTEM CONTROL AND INDICATION	F2000EX EASY
PAGE 6 / 8		CODDE 1
ISSUE 3		DGT94085

REMINDER STATUS

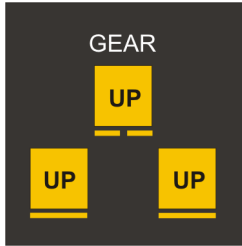

Approach conditions are fulfilled. Gear is up and locked and gear doors are closed. In this case, aural warning and gear handle light are activated.

INVALID DATA



Data transmitted by avionics are declared invalid.

SEQUENCE

Starting with the gear in the UP and LOCKED position



Gear uplocked and door closed



Gear in transit and door open



Gear downlocked and door open during transit



Left or right gear downlocked and door closed



Nose gear downlocked

Starting with the gear in the DOWN and LOCKED position



Left or right gear downlocked and doors closed



Gear in transit and door open



Gear uplocked and door open



Gear uplocked and door closed

F2000EX EASY	ATA 32 – LANDING GEAR AND BRAKING SYSTEM CONTROL AND INDICATION	02-32-15
CODDE 1		PAGE 7 / 8
DGT94085		ISSUE 3

BRAKE TEMPERATURE

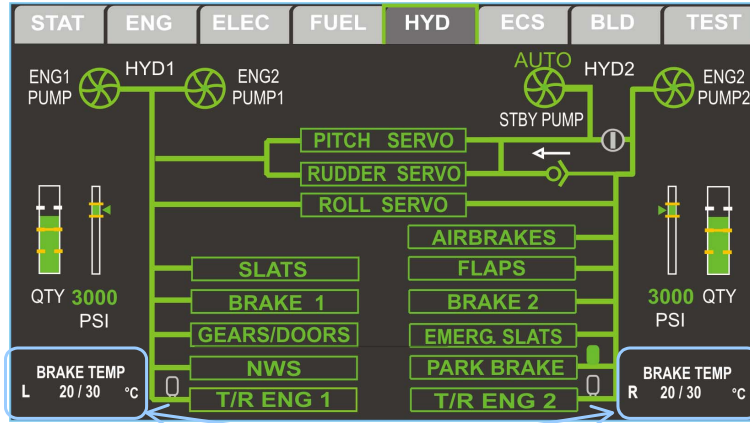

Brake temperature indicators

FIGURE 02-32-15-03 HYDRAULICS SYNOPTIC

ERRONEOUS INDICATIONS

NOSE GEAR TRANSITION

During the nose gear transition, current display logic is incomplete (see figure below). This logic will be corrected in post-certification load.

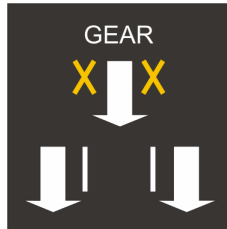

FIGURE 02-32-15-04 NOSE GEAR TRANSITION SYMBOLS

REMINDER STATUS

Current display logic is incomplete. This logic will be corrected in post-certification load.



FIGURE 02-32-15-05 GEAR UP IN APPROACH CONDITIONS

02-32-15	ATA 32 – LANDING GEAR AND BRAKING SYSTEM CONTROL AND INDICATION	F2000EX EASY
PAGE 8 / 8		CODDE 1
ISSUE 3		DGT94085

MAU FAILURE

The worst failure cases are double or triple failure cases. The indications are conservative, and avoid to get into unsafe situation.

This logic will be corrected in post-certification load.

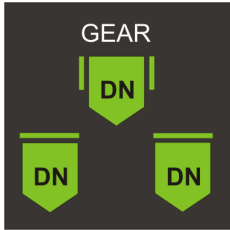
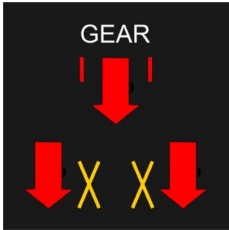
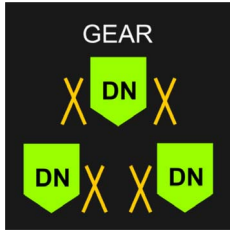
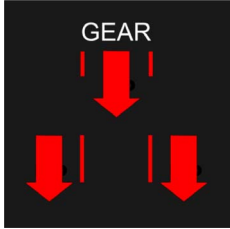
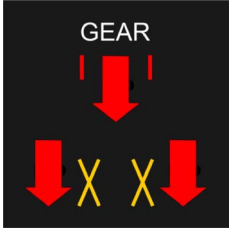
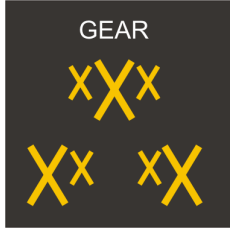
AIRPLANE CONFIGURATION	DISPLAY WARNING	NO MAU FAILURE	MAU 1A+B FAILURE	MAU 2A+B FAILURE
HANDLE DOWN + LANDING GEAR DOWN	HSI		 Arrows white then red after 20 sec	
	CAS	N / A	None	None
	Aural warning	N / A	None	None
	Handle light	N / A	None	None
HANDLE DOWN + LANDING GEAR NOT DOWN	HSI	 Arrows white then red after 20 sec	 Arrows white then red after 20 sec	
	CAS	LANDING GEAR	None	None
	Aural warning	"GEAR"	None	"GEAR"
	Handle light	Flashing	Flashing	None

F2000EX EASY	ATA 32 – LANDING GEAR AND BRAKING SYSTEM SYSTEM PROTECTION	02-32-20
CODDE 1		PAGE 1 / 2
DGT94085		ISSUE 3

INTRODUCTION

The landing gear and braking system are protected by circuit breakers. The wheels are protected against overheat and overpressure.

CIRCUIT BREAKERS

The circuit protection is provided by conventional trip-free circuit breakers located above the overhead panel.



FIGURE 02-32-20-00 CIRCUIT BREAKER PANEL

02-32-20	ATA 32 – LANDING GEAR AND BRAKING SYSTEM SYSTEM PROTECTION	F2000EX EASY
PAGE 2 / 2		CODDE 1
ISSUE 3		DGT94085

WHEELS

The main wheels incorporate:

- three push-in fusible plugs for overheat protection,
- over-inflation protection plug,
- fourteen large ventilation holes to promote increased air circulation for cooling,
- and scalloped key bosses for reduced wheel temperature.

Nose wheel has an over-inflation protection plug.

F2000EX EASY	ATA 32 – LANDING GEAR AND BRAKING SYSTEM NORMAL OPERATION	02-32-25
CODDE 1		PAGE 1 / 2
DGT94085		ISSUE 3

INTRODUCTION

In the following, typical ground and in-flight situations have been selected to help the crew to understand the symbols provided in the various panels and display.

GROUND OPERATION

AIRPLANE ON THE GROUND, PARKING BRAKE APPLIED



FIGURE 02-32-25-00 HSI WINDOW, AIRPLANE ON GROUND, PARKING BRAKE APPLIED

CONTROL POSITION	RESULT
Landing gear handle down	Gear down <three green>
Parking brake applied	PARK BRAKE ON in CAS area

02-32-25	ATA 32 – LANDING GEAR AND BRAKING SYSTEM NORMAL OPERATION	F2000EX EASY
PAGE 2 / 2		CODDE 1
ISSUE 3		DGT94085

IN-FLIGHT OPERATION



FIGURE 02-32-25-01 HSI WINDOW AFTER TAKE-OFF

CONTROL POSITION	RESULT
Landing gear handle up	Gear up and doors closed UP symbols for 10 sec

F2000EX EASY	ATA 32 – LANDING GEAR AND BRAKING SYSTEM ABNORMAL OPERATION	02-32-30
CODDE 1		PAGE 1 / 2
DGT94085		ISSUE 3

INTRODUCTION

In the following, typical abnormal situations have been selected to help the crew to understand the symbology provided in the various panels and displays.

GEAR IN TRANSIT WITH TOO LONG EXTENSION TIME



FIGURE 02-32-30-00 HSI WINDOW, GEAR IN TRANSIT WITH TOO LONG EXTENSION TIME

CONTROL POSITION	RESULT
Landing gear handle down	If gear not downlocked after 20 sec: - gear handle flashing - red arrow replacing gear symbol

02-32-30	ATA 32 – LANDING GEAR AND BRAKING SYSTEM ABNORMAL OPERATION	F2000EX EASY
PAGE 2 / 2		CODDE 1
ISSUE 3		DGT94085

TOTAL LOSS OF HYDRAULIC POWER

LANDING GEAR

In case of total hydraulic power loss, the landing gear can still be extended manually with the three emergency gear handles.

BRAKING SYSTEM

In case of total hydraulic power loss, braking is still possible, using parking brake handle, thanks to the brake accumulator.

CAUTION

Do not go beyond the first parking brake detent during landing roll.

CAS MESSAGES

CAS MESSAGE	DEFINITION
BOTH BRAKE SYSTEM	Total failure of both brake systems. Only emergency park braking is available
BRAKE ACCU	Hydraulic pressure in parking brake system is less than 1,900 psi
BRAKE CMPTR .. FAULT CODE	On ground, a failure message that may affect dispatch was recorded by BRAKE computer (1/2)
BRAKE PRESS	Pressure is detected in one brake while pedals are at rest
BRAKE .. FAIL	Failure of braking system (1/2)
LANDING GEAR	Landing gear failed to extend completely 20 seconds after commanded down
LANDING GEAR NOT UP	Landing gear failed to retract completely 20 seconds after commanded up
NWS FAILED	Failure of nose wheel steering systems
BRAKE CMPTR .. FAULT CODE	In flight, a failure message has been recorded by the brake computer system (1/2)
PARK BRAKE ON	On ground, indication that parking brake is applied