

Example 9: Seismic Zone 1 Design Example

Problem Statement

Most bridges in Colorado fall into the Seismic Zone 1 category. Per AASHTO, no seismic analysis is required for structures in Zone 1. However, seismic criteria must be addressed in this case. This example illustrates the seismic-specific code requirements associated with bridges in Zone 1, including:

AASHTO
4.7.4

- Determination of seismic zone
- Horizontal connection forces
- Minimum support length requirements
- Substructure transverse reinforcement requirements

This example bridge is a skewed, 2-span, steel I-girder bridge supported by semi-integral abutments and a multi-column pier, with a drop style pier cap and each column supported by a single caisson (see Figures 1 and 2). The caisson reinforcing clear cover allows the same reinforcing cage diameter to be used for both column and caisson.

Fixed Type 1 bearings are used at the pier while expansion Type 1 bearings are used at the abutments. Anchor bolts projecting through a sole plate are assumed as the restraint mechanism at the bearings, with the holes in the sole plate slotted in the longitudinal direction at the abutments. Note that integral abutments would typically be specified for a bridge with this span arrangement, but expansion abutments are included for illustrative purposes.

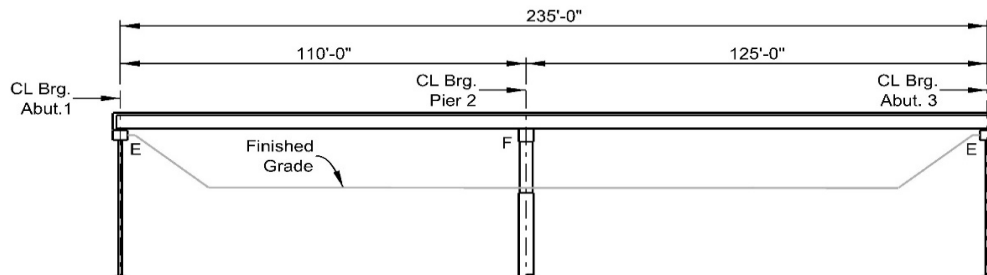

Figure 1 - Bridge Layout and Longitudinal Fixity

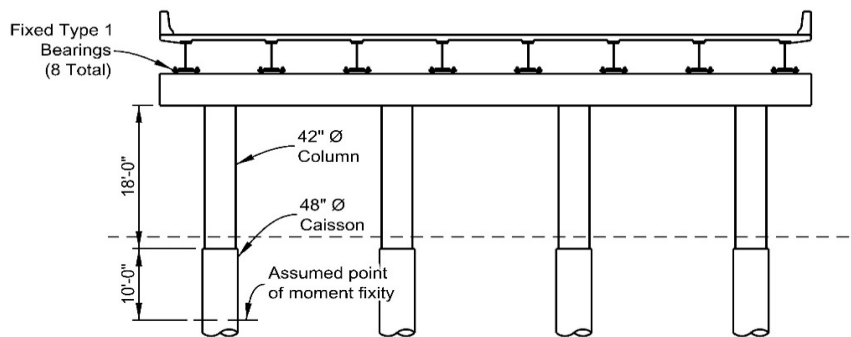

Figure 2 - Pier 2 Elevation

Givens

Total Bridge Length, L =	235.00	ft.	
Pier 2 Column Height, H =	18.00	ft.	See Figure 2
Bridge Skew, S =	5.00	degrees	
Abutment Support Length =	36.00	in.	
Extreme Event I LL Factor, γ_{EQ} =	0.00		AASHTO 3.4.1
Earthquake Load Factor, γ =	1.00		AASHTO 3.4.1
Permanent Vertical Reaction at Abut. 1, R_1^1 =	494	kip per Abutment	
Permanent Vertical Reaction at Pier 2, R_2^1 =	1759	kip per Pier	
Permanent Vertical Reaction at Abut. 3, R_3^1 =	561	kip per Abutment	
Column Diameter, D =	42.0	in.	
Column Clear Cover =	2.00	in.	
Caisson Diameter, D_c =	48.0	in.	
Caisson Clear Cover =	5.00	in.	
Assumed Depth to Moment Fixity ² =	10.00	ft.	See Figure 2
f'_c , Column =	4.50	ksi	
f'_c , Caisson =	4.00	ksi	
f_y =	60.00	ksi	

Seismic Design Parameters:³

Site Class =	D	A_s =	0.165 g
PGA =	0.103 g	S_{DS} =	0.338 g
S_s =	0.212 g	S_{D1} =	0.127 g
S_1 =	0.053 g		

¹ These values are the unfactored total for the support.

² Assumed for this example, Designers should determine analytically for each project.

³ Provided by Geotechnical Engineer for an event with a 7% probability of exceedance in 75 years.

Determination of Seismic Zone

Bridges are assigned to seismic zones based on the S_{D1} parameter and Table 3.10.6-1 in AASHTO, re-created here:

Acceleration Coefficient, S_{D1}	Seismic Zone
$S_{D1} \leq 0.15$	1
$0.15 < S_{D1} \leq 0.30$	2
$0.30 < S_{D1} \leq 0.50$	3
$0.50 < S_{D1}$	4

Since $S_{D1} = 0.127 < 0.15$, the bridge is located in Seismic Zone 1.

Horizontal Connection Force:

AASHTO 3.10.9.2

For bridges in Zone 1, the horizontal design connection force is a function of the acceleration coefficient, A_S .

Since $A_S = 0.165 \geq 0.05$, the minimum horizontal design connection force is 0.25 times the vertical reaction due to tributary permanent load and the tributary live loads assumed to exist during an earthquake. For this example, the tributary live load is assumed to be zero. See BDM Section 3.12 for guidance on the value of γ_{EQ} to use when performing a seismic analysis for bridges in other seismic zones.

This calculation is performed for both longitudinal and transverse directions.

Longitudinal Direction

Since the abutment bearings allow expansion in the longitudinal direction, the superstructure is restrained only by the 8 fixed bearings at Pier 2. Any passive soil resistance that may develop behind the abutments is ignored. The design connection force in the longitudinal direction at Pier 2 is 0.25 times the sum of the permanent vertical reactions at all supports.

$$\begin{aligned} \text{Tributary reaction at Pier 2} &= R_1 + R_2 + R_3 \\ &= 2814 \text{ kip} \\ 0.25 \text{ times reaction} &= 704 \text{ kip} \end{aligned}$$

The factored horizontal design connection force for each bearing:

$$= 1.0 * 704 / 8 = 88.0 \text{ kip}$$

Transverse Direction

The superstructure is restrained in the transverse direction at all three supports. Therefore, the design connection forces in the transverse directions are a function of the permanent vertical reactions at each support. Each support has 8 bearings.

$$\begin{aligned} \text{Tributary reaction for Abutment 1, } R_1 &= 494 \text{ kip} \\ 0.25 \text{ times reaction} &= 124 \text{ kip} \end{aligned}$$

The factored horizontal design connection force for each bearing at Abutment 1:

$$= 1.0 * 124 / 8 = 15.5 \text{ kip}$$

$$\begin{aligned} \text{Tributary reaction for Pier 2, } R_2 &= 1759 \text{ kip} \\ 0.25 \text{ times reaction} &= 440 \text{ kip} \end{aligned}$$

The factored horizontal design connection force for each bearing at Pier 2:

$$= 1.0 * 440 / 8 = 55.0 \text{ kip}$$

$$\begin{aligned} \text{Tributary reaction for Abutment 3, } R_3 &= 561 \text{ kip} \\ 0.25 \text{ times reaction} &= 140 \text{ kip} \end{aligned}$$

The factored horizontal design connection force for each bearing at Abutment 3:

$$= 1.0 * 140 / 8 = 17.5 \text{ kip}$$

Resolution of Horizontal Connection Forces

Because the bearing devices provide horizontal restraint for the bridge, Designers should verify the capacity of the following items with respect to the connection force: the girder to sole plate connection, the sole plate to anchor bolt connection, the anchor bolt, and anchor bolt anchorage into concrete.

The transverse and longitudinal connection forces determined above are simplified approximations AASHTO allows for Zone 1, in lieu of performing a refined seismic analysis using stiffness based force distribution. As such, the horizontal and longitudinal connection forces need not be combined as described in AASHTO 3.10.8, the provisions of which are predicated on a perpendicular seismic analysis.

Adequate resistance of the connection force shall be verified at any connection (not necessarily just bearing devices) whose failure could cause loss of support or structure instability, as described in AASHTO C3.10.9.2. Previous versions of AASHTO required that the connection force be addressed from the point of application through the substructure and into the foundation elements. However, the 2015 Interim Revisions to AASHTO removed this requirement.

Minimum Support Length Requirements

AASHTO 4.7.4.4

Because no longitudinal restraint is provided at Abutment 1 or 3, the support lengths must meet the requirements of AASHTO 4.7.4.4. Note that bearings with anchors in slotted holes are not considered restrained in the direction of the slots.

The minimum support length, N, measured normal to the centerline of bearing is:

$$N = (8 + 0.02L + 0.08H)(1 + 0.000125 * S^2)$$

AASHTO
4.7.4.4-1

where:

- L = Length of bridge deck to the adjacent expansion joint or to the end of the bridge deck
- H = Average height of columns supporting the bridge deck from the abutment to the next expansion joint (definition for abutments only)
- S = Skew of support measured from line normal to span (degrees)

$$N = (8 + 0.02 * 235' + 0.08 * 18')(1 + 0.000125 * 5^2)$$

$$N = 14.2 \text{ in.}$$

The percentage of N required for a given seismic zone and A_S is shown in AASHTO Table 4.7.4.4-1. For Seismic Zone 1 and with $A_S = 0.165$, 100% of N (14.2 inches) is required. The support length provided is 36 in., thus the minimum support requirements are satisfied.

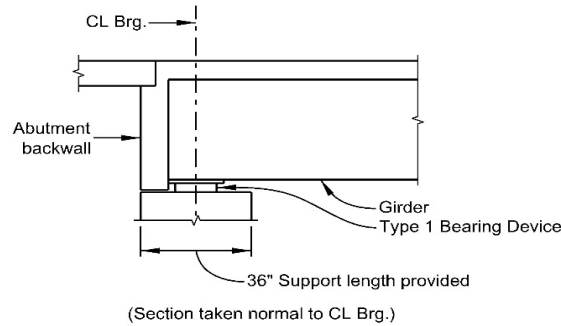

Figure 3 - Abutment Support Length

Substructure Transverse Reinforcement Requirements

AASHTO 5.11

In addition to connection force requirements, for bridges in the high end of Seismic Zone 1 where the response acceleration coefficient S_{D1} is greater than 0.10, transverse confinement reinforcement is required in the expected plastic hinge regions. AASHTO 5.11.2 assumes the plastic hinges zones to be located at the top and bottom of columns. However, the actual locations of plastic hinges depend on support geometry and boundary conditions and must be determined on a project-specific basis. Transverse confinement reinforcement need only be provided in the expected plastic hinge regions.

AASHTO 5.11.2

Since $S_{D1} = 0.127$, confinement reinforcement as specified in AASHTO 5.11.4.1.4 and 5.11.4.1.5 must be provided.

Transverse Reinforcement for Confinement at Plastic Hinges

AASHTO 5.11.4.1.4

Seismic hoop or spiral transverse reinforcement is required in the expected plastic hinge regions. Per BDM Section 5.4.9, CDOT prefers spirals for confinement reinforcement of round elements.

For a circular member, the volumetric ratio, ρ_s , of spiral reinforcement shall satisfy either of the following:

$$\rho_s = \frac{4A_{sp}}{D_{core}s} \geq 0.45 * \left(\frac{A_g}{A_c} - 1 \right) \frac{f'_c}{f_y} \quad \text{AASHTO 5.6.4.6-1}$$

$$\rho_s = \frac{4A_{sp}}{D_{core}s} \geq 0.12 \frac{f'_c}{f_y} \quad \text{AASHTO 5.11.4.1.4-1}$$

where:

- f'_c = specified 28-day compressive strength of concrete (ksi)
- f_y = minimum yield strength of reinforcing (ksi) ≤ 75.0 ksi
- A_g = gross area of concrete section (in.²)
- A_c = area of the core measured to the outside diameter of the spiral (in.²)
- A_{sp} = cross-sectional area of spiral or hoop (in.²)
- D_{core} = core diameter of column measured to the outside of spiral or hoop (in.)
- s = pitch of spiral or vertical spacing of hoops (in.)

Recall that:

Column Diameter, D =	42.0	in.
Column Clear Height, H =	18.0	ft.
Column Clear Cover =	2.00	in.
Caisson Diameter, D _c =	48.0	in.
Caisson Clear Cover =	5.00	in.

Column Spiral:

$$D_{core} = D - 2 * (\text{clear cover})$$

$$D_{core} = 38.0 \text{ in.}$$

$$A_g = \pi \left(\frac{D}{2} \right)^2$$

$$A_g = 1385 \text{ in.}^2$$

$$A_c = \pi \left(\frac{D_{core}}{2} \right)^2$$

$$A_c = 1134 \text{ in.}^2$$

The volumetric ratio of spiral reinforcement, ρ_s, must satisfy either of the following:

$$\rho_s \geq 0.45 * \left(\frac{1385 \text{ in.}^2}{1134 \text{ in.}^2} - 1 \right) \frac{4.5 \text{ ksi}}{60 \text{ ksi}} \quad \text{AASHTO 5.6.4.6-1}$$

$$\geq 0.0075$$

$$\rho_s \geq 0.12 \frac{4.5 \text{ ksi}}{60 \text{ ksi}} \quad \text{AASHTO 5.11.4.1.4-1}$$

$$\geq 0.0090$$

$$\rho_{s, \text{min}} = 0.0075$$

AASHTO 5.11.4.1.5 limits the spacing of confinement reinforcement to 1/4th the member diameter, D, or 4.0 in. The 4.0 in. maximum spacing controls.

$$\text{Try \#5 spirals at pitch, } s = 4.00 \text{ in.}$$

$$\text{\#5 diameter} = 0.625 \text{ in.}$$

$$\text{Spiral diameter, } d_s = D_{core} - 0.625"$$

$$d_s = 37.38 \text{ in}$$

The required area of one leg of the spiral, A_{sp}:

$$A_{sp} = \frac{\rho_{s, \text{min}} * s * D_{core}^2}{4 * d_s} \cong \frac{\rho_s * s * D_{core}}{4}$$

$$A_{sp} = 0.29 \text{ in.}^2$$

As a #5 bar has a cross-sectional area of 0.31 in.², using #5 spirals at a 4.0 in. pitch satisfies the confinement requirements.

AASHTO
5.11.4.1.4

Lap splices of the confinement reinforcement in the hinge zone are not permitted; rather, splices shall be made by full-welded splices or by full-mechanical connections. AASHTO C5.11.4.1.4 also recommends spacing longitudinal bars a maximum of 8 in. to help confinement (see Figure 4).

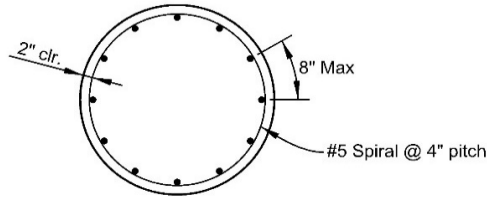

Figure 4 - Column Confinement Reinforcement

Caisson Spiral:

$$\text{Core diameter, } D_{\text{core}} = D_c - 2 * (\text{clear cover})$$

$$D_{\text{core}} = 38.0 \text{ in.}$$

$$A_g = \pi \left(\frac{D_c}{2} \right)^2$$

$$A_g = 1810 \text{ in.}^2$$

$$A_c = \pi \left(\frac{D_{\text{core}}}{2} \right)^2$$

$$A_c = 1134 \text{ in.}^2$$

The volumetric ratio of spiral reinforcement, ρ_s , must satisfy either of the following:

$$\rho_s \geq 0.45 * \left(\frac{1810 \text{ in.}^2}{1134 \text{ in.}^2} - 1 \right) \frac{4.0 \text{ ksi}}{60 \text{ ksi}}$$

$$\geq 0.0179$$

AASHTO
5.6.4.6-1

$$\rho_s \geq 0.12 \frac{4.0 \text{ ksi}}{60 \text{ ksi}}$$

$$\geq 0.0080$$

AASHTO
5.11.4.1.4-1

$$\rho_s, \text{ min} = 0.008$$

Try #5 spirals at pitch, $s = 4.00 \text{ in.}$

#5 diameter = 0.625 in.

Spiral diameter, $d_s = D_{\text{core}} - 0.625"$

$$d_s = 37.38 \text{ in.}$$

The required area of one leg of the spiral, A_{sp} :

$$A_{\text{sp}} = \frac{\rho_s, \text{ min} * s * D_{\text{core}}^2}{4 * d_s} \cong \frac{\rho_s * s * D_{\text{core}}}{4}$$

$$A_{\text{sp}} = 0.31 \text{ in.}^2$$

A #5 spiral at a 4.0 in. pitch satisfies the confinement requirements (see Figure 5).

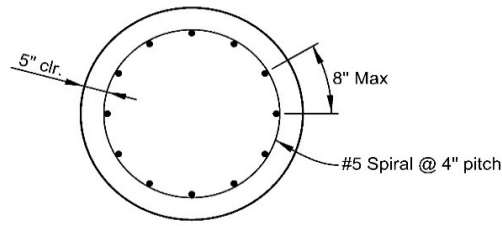

Figure 5 - Caisson Confinement Reinforcement

AASHTO
5.11.4.1.5

Spacing of Transverse Reinforcement for Confinement

AASHTO 5.11.4.1.5 gives guidance on the required lengths where confinement reinforcement is required. As the example column and caisson have similar flexural stiffnesses and capacities, their seismic behavior, including location of plastic hinges, is expected to be similar to that of a pile bent. Therefore, the provisions of AASHTO 5.11.4.1.5 that pertain to pile bents are followed. Further, the column clear height parameter is increased by the assumed depth to fixity to more accurately reflect the bending height of the column/caisson element.

At the top of the column, confinement reinforcement must be provided over a length not less than:

- the maximum cross-sectional column dimension,

$$\text{Column Diameter, } D = 3.50 \text{ ft.}$$
- 1/6th of the bending height of the column/caisson,

$$1/6*(H+10') = 4.67 \text{ ft.} \quad < \text{Controls}$$
- or 18 in.

$$18.0 \text{ in.} = 1.50 \text{ ft.}$$

And extend into the adjoining pier cap for a distance not less than:

- one-half the maximum column dimension

$$D/2 = 1.75 \text{ ft} \quad < \text{Controls}$$
- or 15 in.

$$15.0 \text{ in.} = 1.25 \text{ ft}$$

AASHTO
5.11.4.3

In accordance with the provisions for pile bents, confinement reinforcement must be provided in the caisson over a length extending from 3.0 times the diameter below the point of moment fixity in the caisson to a height of one diameter, but not less than 18 in., above the mud line.

Figure 6 shows the resulting hinge zones and reinforcement.

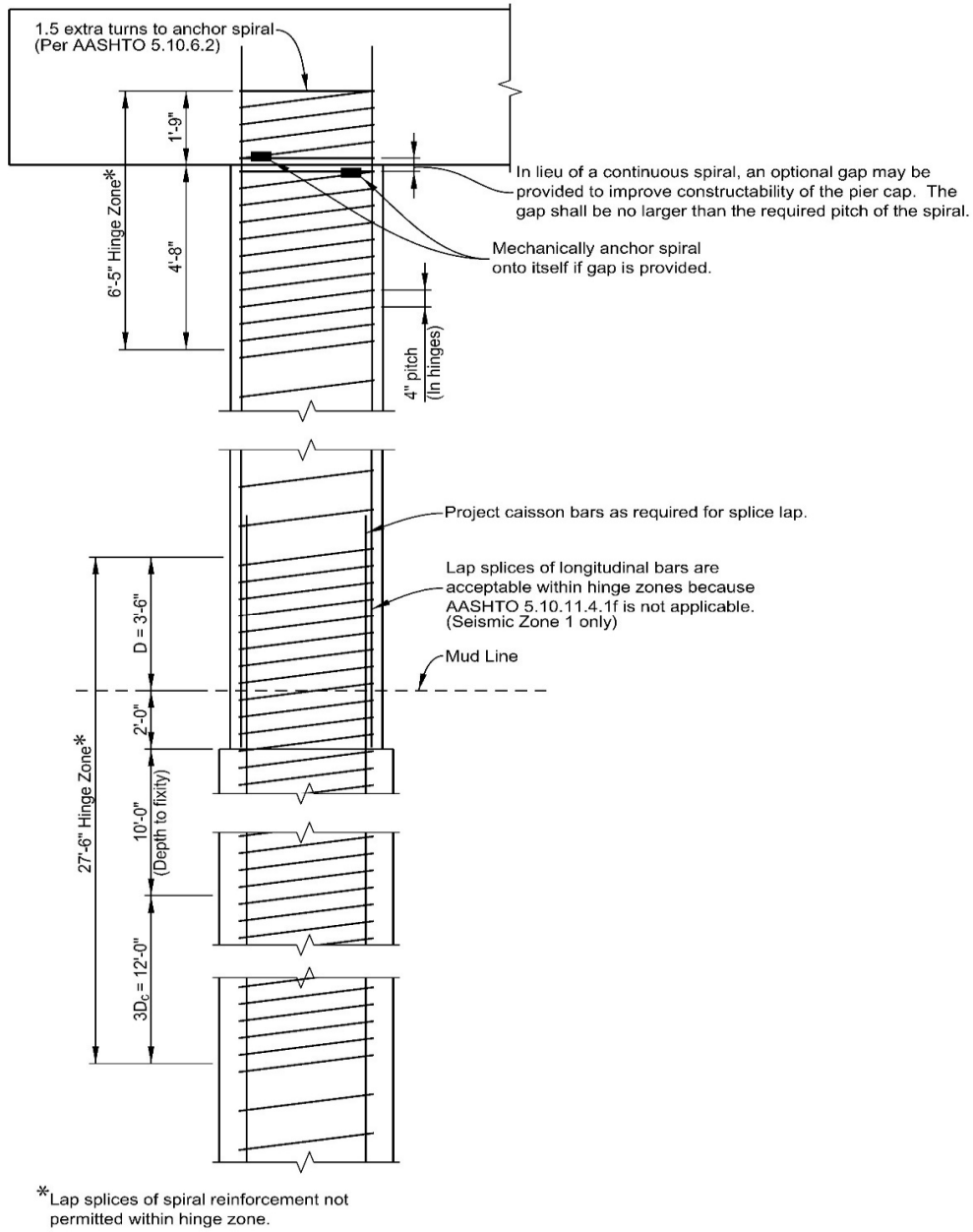

Figure 6 - Hinge Zone Reinforcement

Conclusion

Horizontal design connection forces and minimum seat lengths are typically critical for bridges that use bearing devices, which the example bridge highlighted. Guidelines for other common CDOT situations with respect to horizontal connection forces are as follows:

- Standard CDOT integral abutments that are designed and detailed per BDM Section 11.3.1 are considered restrained in all directions and may be assumed to meet horizontal design connection force requirements by inspection.
- The typical CDOT “pinned” piers where the girders are embedded in concrete pier diaphragms that are connected to the pier cap with a single line of dowels, require Designers to check the doweled connection to the diaphragm for the horizontal connection force. Shear friction at the pier diaphragm to pier cap interface should be used as the resistance.

The example also showed the transverse confinement reinforcement requirements (applicable when $0.10 \leq S_{D1} \leq 0.15$) for the common CDOT configuration of a single caisson supporting each column of a multi-column pier, and where the caisson and column are of similar size. The following guidelines are applicable to other common CDOT substructure configurations, when $0.10 \leq S_{D1} \leq 0.15$:

- Transverse confinement reinforcement for hinging need not be specified at the tops of columns that exhibit cantilever behavior in both horizontal directions, regardless of the S_{D1} magnitude. This is because a plastic hinge cannot form where there is no significant moment development possible.
- For the situation where a significantly larger caisson is used under each column and the column bars are embedded into the caisson, the lower hinge during an earthquake is likely to occur at the bottom of column, not within the caisson. In this case, the hinge zone for the column may use the actual clear column height to establish the upper and lower column hinge zone limits. The caisson is then considered an adjoining member, and the column’s confinement reinforcement should be extended into the caisson as required in AASHTO 5.11.4.3. The caisson’s transverse reinforcement need not meet the special requirements for confinement at plastic hinges.
- For the situation where a caisson is significantly smaller than the column that is used, and the caisson bars project into the column, the lower hinge during an earthquake is likely to occur in the caisson. The “pile bent” criteria shown in the example should be used to establish the top and bottom hinge zone limits, except that confinement reinforcement need not be provided for the bottom of column as no plastic hinge is expected there. The caisson transverse confinement reinforcement should be extended into the column as required in AASHTO 5.11.4.3 for adjoining members.

Example 9 followed AASHTO LRFD provisions for Seismic Zone 1. As an alternative, Designers may follow the *AASHTO Guide Specifications for LRFD Seismic Bridge Design*. Note that the equivalent to AASHTO LRFD Seismic Zone 1 is Seismic