

ESCALATORS &
MOVING WALKS
planning guide

ThyssenKrupp Elevator Americas



ThyssenKrupp

Keeping You in Motion.

The world is in constant motion. Every day sees a growing flow of active people winding their way through urban landscapes. This flow creates high demands in a fast-paced environment, and ThyssenKrupp Elevator’s escalators and moving walks convert chaos into simple pleasure.

Escalators and moving walks are an indispensable part of a mobile society. Whether in department stores, train stations, modern stadiums, luxury casinos, hotels, office complexes or airports, ThyssenKrupp Elevator products keep people moving safely and effectively in virtually all areas of public life.

This planning guide has been prepared to introduce you to ThyssenKrupp Elevator’s escalators and moving walks, while assisting you with the layout of your projects. Our vertical transportation experts look forward to working with you to implement new and creative ideas.

For additional assistance with your escalator planning needs, contact your local ThyssenKrupp Elevator representative or call (877) 230-0303.

Sustainability.

ThyssenKrupp Elevator’s journey toward sustainability has shown us that we can address today’s needs without compromising the needs of future generations. Our ability to address industry requirements through the development of sustainable products and practices and achieve our own goals through reduction in material use, energy and waste, encourages us to see where this journey can take us.

ThyssenKrupp Elevator recognizes the great potential for reducing the environmental impact of existing escalators through modernization and upgrades, which can increase energy efficiency, reduce contaminants and eliminate unnecessary waste.

We offer controllers that incorporate E-Save Technology™, which provides 25-30% energy savings when compared to conventional escalator controls. This fully ASME A17.1 code-compliant product continually monitors passenger load and provides the precise amount of power required. When the escalator is under light or no load, the power to the motor is reduced, effectively lowering energy consumption and costs. When passenger load increases, the power to the motor accelerates for a smooth and efficient ride. All of this takes place while maintaining the rated speed of the escalator.

Table of Contents

Commercial Duty Escalator	4-5
Heavy Duty Escalator	6-7
Transit Duty Escalator	8
Moving Walks	9
I.MOD	10-11
Escalator & Moving Walks Options	12
Overview	13
Dimensions and Data	14
Safety Manual	15-16
Installation Possibilities	17-18
Preparations by Others	19-22
Section and Plan View	23
Work by Others	24

About ThyssenKrupp Elevator.

ThyssenKrupp Elevator Americas is the largest producer of elevators in the Americas, with over 13,500 employees, more than 200 branch and service locations, and sales of over 2.7 billion US dollars. ThyssenKrupp Elevator Americas oversees all business for the operations in the USA, Canada, Central and South Americas. It is a subsidiary of ThyssenKrupp Elevator AG. The Elevator Technology business area brings together the ThyssenKrupp Group’s global activities in passenger transportation systems. With 44,000 employees, sales of 7.1 billion US dollars in fiscal 2009/2010 and customers in 150 countries, ThyssenKrupp Elevator is one of the world’s leading elevator companies.

ThyssenKrupp USA, Inc. and its subsidiaries account for approximately 17,500 employees and annual sales of 6.7 billion US dollars in fiscal year 2009/2010. Through its predecessor companies, ThyssenKrupp has been a part of the US industrial landscape for over 170 years.

Overview: Escalator and Moving Walks

Commercial Duty Escalators

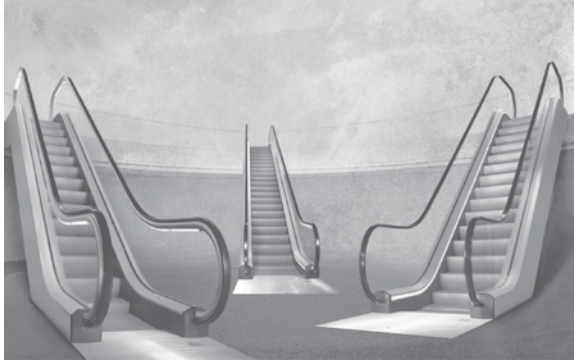

Two models, one distinction.

More design features for modern buildings, including under-handrail lighting, stainless steel or custom powder-coated finishes. All models combine attractive design with the latest escalator technology for increased comfort and safety. Available for both indoor and outdoor applications.

Heavy Duty Escalators



Never have high-traffic escalators looked so good.

Whether with a glass or metal balustrade, the heavy-duty models are made to direct the traffic of tomorrow. Economical, robust and featuring advanced technology, our heavy-duty line is designed specifically for high-traffic, higher-rise institutional applications. Available for both indoor and outdoor applications.

Transit Duty Escalators



Our most powerful model.

Extremely capable and designed for reliable 24-hour service, this escalator was designed for subway and other extreme high-traffic applications, designed with travel heights up to 164'-0" (50 m). Fully APTA (American Public Transit Association) compliant. Available for both indoor and outdoor applications.

Moving Walks



Innovative walks.

A range of lighting systems and balustrade profiles make ThyssenKrupp Elevator moving walks the perfect complement for shopping malls, exhibition centers and airports. Its innovative design, coupled with state-of-the-art engineering and technology, gives it exemplary qualities for adapting to the prevailing architecture. Available for both indoor and outdoor applications.

ThyssenKrupp Elevator outdoor application escalators include as a minimum :

Galvanized truss structure, protective chain covers, automatic lubrication, handrails with nylon sliders, stainless steel handrail guides, oil/water separator in lower pit floor and stainless steel fasteners for all exposed surfaces.

Restrained and inviting.

Conspicuously discreet: The Velino Commercial Duty escalator features a design oriented, slim line balustrade. The remarkable lightness of the Velino is due to its 40-inch high balustrade and innovative, almost invisible, handrail guide which leaves the impression that the handrail rides directly on the glass.

The Velino escalator's cultured reserve and clean lines never place it in competition with the surrounding architecture. Rather, it leaves the architect with the opportunity to establish carefully placed accents in both new and existing environments.

Remarkable. Dependable.
That is what you get from the ThyssenKrupp Elevator label.



Velino: Commercial Duty Escalator

Enduring and elegant.

A machine that moves thousands of people every day must be properly equipped to do so. The Velino Commercial Duty escalator is a workhorse, available with a reinforced aluminum under-handrail profile that can take any passenger volume in stride.



ThyssenKrupp's Velino escalator proves that stability and elegance are not mutually exclusive. The balustrade's 3/8" (10mm) thick tempered safety glass panels and optional under-handrail lighting provide the Velino escalator with striking aesthetics while performing under the most demanding of conditions.

We have, however, given the Velino escalator more than just an attractive look. It is the most technologically advanced escalator currently available. Dual CPU controllers and optional VVF drive technology keep the Velino products at the front of the class.

The Velino escalator is also available with a hi-deck, stainless steel balustrade design suitable for building locations where glass balustrades may not be desirable; such as where walls or other building structures are directly adjacent to the escalators.

Convincing over short and long distances.

With its discreet 40-inch high glass balustrade, ThyssenKrupp's heavy-duty Tugela escalator fits perfectly into every environment. As much as it flatters the eye of the observer, it pampers the user with incomparable ride comfort. This escalator is typically designed for higher-rise applications [$>33'-0"$ (10058 mm)] and locations where heavy crush loads are the norm, such as convention centers, stadiums and airports. Increased motor and chain sizing, combined with modified handrail drive and tension carriage design, separate the Tugela from the Velino product line.

Naturally, the reinforced balustrade is made of tempered safety glass, making it resistant to bumps and knocks from bags and cases. Moreover, a world of customized options is available, including diverse glass colors and optional under handrail lighting.

No matter what ideas you have in mind for your heavy-duty escalator, we assure you that these can be achieved with the Tugela escalator.



Tugela: Heavy Duty Escalator

Always on track for success.

ThyssenKrupp's Tugela escalator has performance and efficiency that are evident from a distance. But to regard it as a pure power packet would do it an injustice: its stainless steel, high-deck balustrade design will complement every enclosed environment.

Constructed for demanding operational requirements in large transport facilities or underground railway stations, the Tugela escalator will handle all of your needs.

From tropical climates to the most frigid regions, ThyssenKrupp's escalators have you covered. Warm-weather climates do not affect Tugela's perfection in performance. And for cold-temperature areas, we offer an optional integrated heating package to melt ice and snow to assure passenger safety. This feature is available on all ThyssenKrupp Escalator models.

Our escalators are made individually to suit the specific building design parameters.



The one that sets the masses in motion.

There are moments in the life of an escalator when it would be ill advised to stop; for example, when large numbers of people are taking it by storm. Wherever such moments arise, ThyssenKrupp's Victoria transit duty escalator is the ideal solution.

The Victoria transit duty escalator is the strongest, most powerful ThyssenKrupp model. Its purpose-developed chain with external 4" rollers accommodates rises up to 164'-0" (50 m). With its specially reinforced drive system, it is capable of maximum performance at full-load capacity around-the-clock.

Minimum failure rates, maximum safety standards and optimum servicing simplicity allow for problem-free operation. No wonder the Victoria is constantly putting in an appearance at the most frequented places in the world: railway stations, airports, subway stations, and wherever else there's plenty of life - day in, day out.

Available with glass or high deck balustrades, ThyssenKrupp's Victoria product is fully APTA compliant.

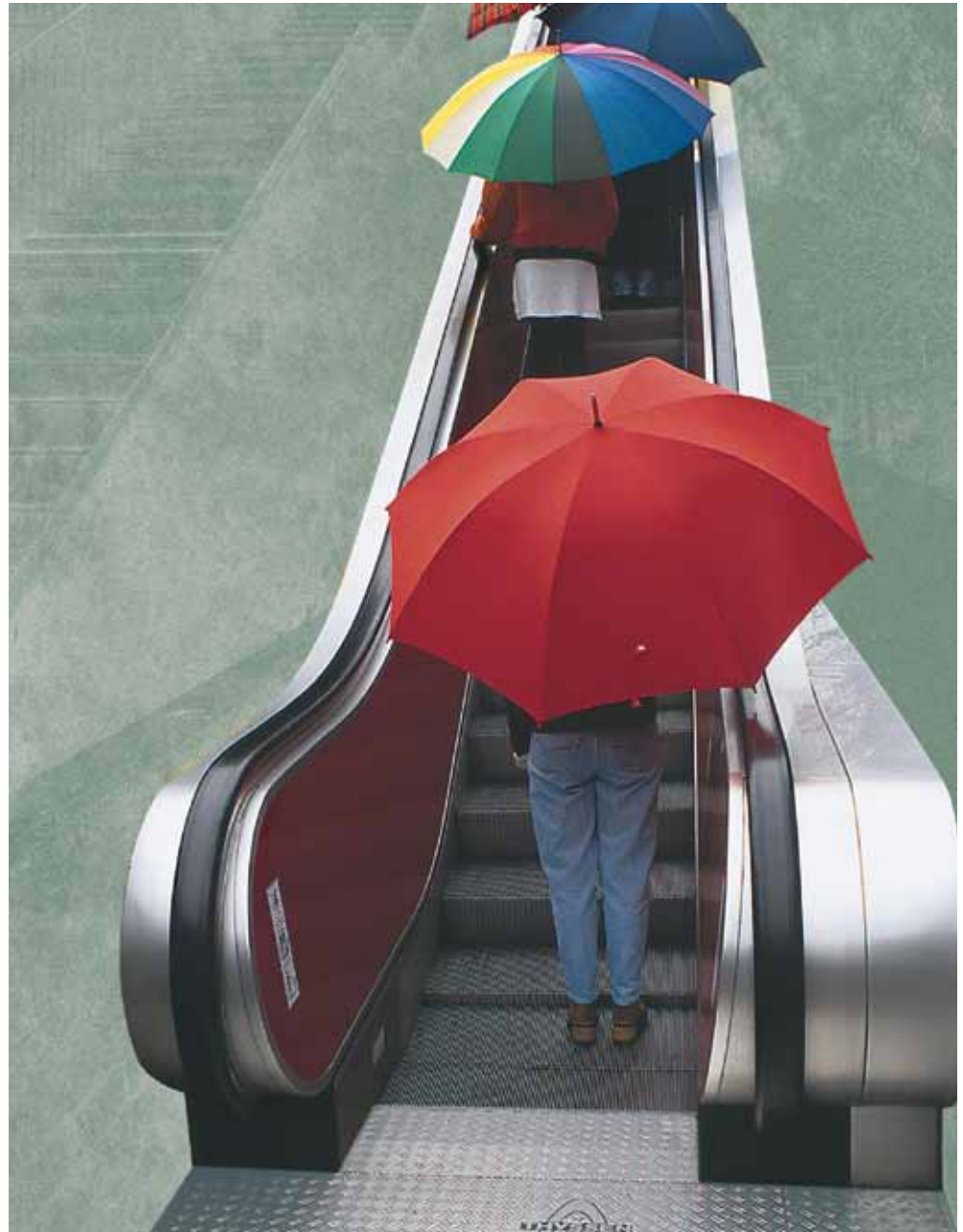

Orinoco: Moving Walks

Reliable and resilient.

Airports increasingly play a major role in modern urban life. They are transport hubs for an endless flow of people on a round-the-clock basis. It is therefore no surprise that moving walks made by ThyssenKrupp are frequently found in these sensitive locations.



ThyssenKrupp Elevator's Orinoco moving walk, with its continuous 40-inch high 3/8-inch thick tempered safety glass balustrade or high deck stainless steel, takes knocks and bumps from suitcases, bags and luggage in stride.

The qualities of this moving walkway, however, are not limited to its exterior attributes. Quality at ThyssenKrupp Elevator has always been the sum total of all factors. Hidden away on the inside is new conveyor technology that delivers the highest reliability which is essential to meet present day requirements.

A workhorse like this, however, need not look like one. Therefore, a multitude of design options allows the moving walk to harmonize perfectly with any type of architecture.

Modernization.

We define a *modernization* of an escalator or moving walk as a process wherein the existing truss structure is *retained* while all other components are removed and replaced with new proven *heavy-duty* components.

Often, building access limitations prevent the replacement of the entire escalator or moving walk structure. In this case, we will *modernize* your equipment. Our I.MOD is a perfect solution, as it also allows you to retain existing custom cladding finishes which match the lobby aesthetics while providing new escalator performance.

In addition to our industry-leading reliability and safety standards, our I.MOD package is part of ThyssenKrupp Elevator's environmental initiative. It provides a choice of two energy-saving control systems; both of which reduce electrical consumption by approximately 30%. Lubrication free chains are also standard equipment with our I.MOD package.

ThyssenKrupp Elevator is dedicated to continually evolving technology and being an industry leader in escalator design, manufacturing, installation *and modernization*.

I.MOD Process.

Removal of the existing escalator's components including the following:

- Floor plates, combplate assemblies
- Handrails, handrail drive system
- Balustrades, skirts, deckings, mounting hardware
- Steps, chains, axels, rollers
- Step tracks and structure
- Motor, gear box, brake
- Main drive sprocket assembly, lower tension carriage systems
- Controls, piping, electrical equipment

The existing truss is cleaned, repainted and prepared for the installation of the new I.MOD component package. Heavy duty upper, lower and incline modules are installed and aligned. Following module installation, all new escalator components and finishes are installed and adjusted.

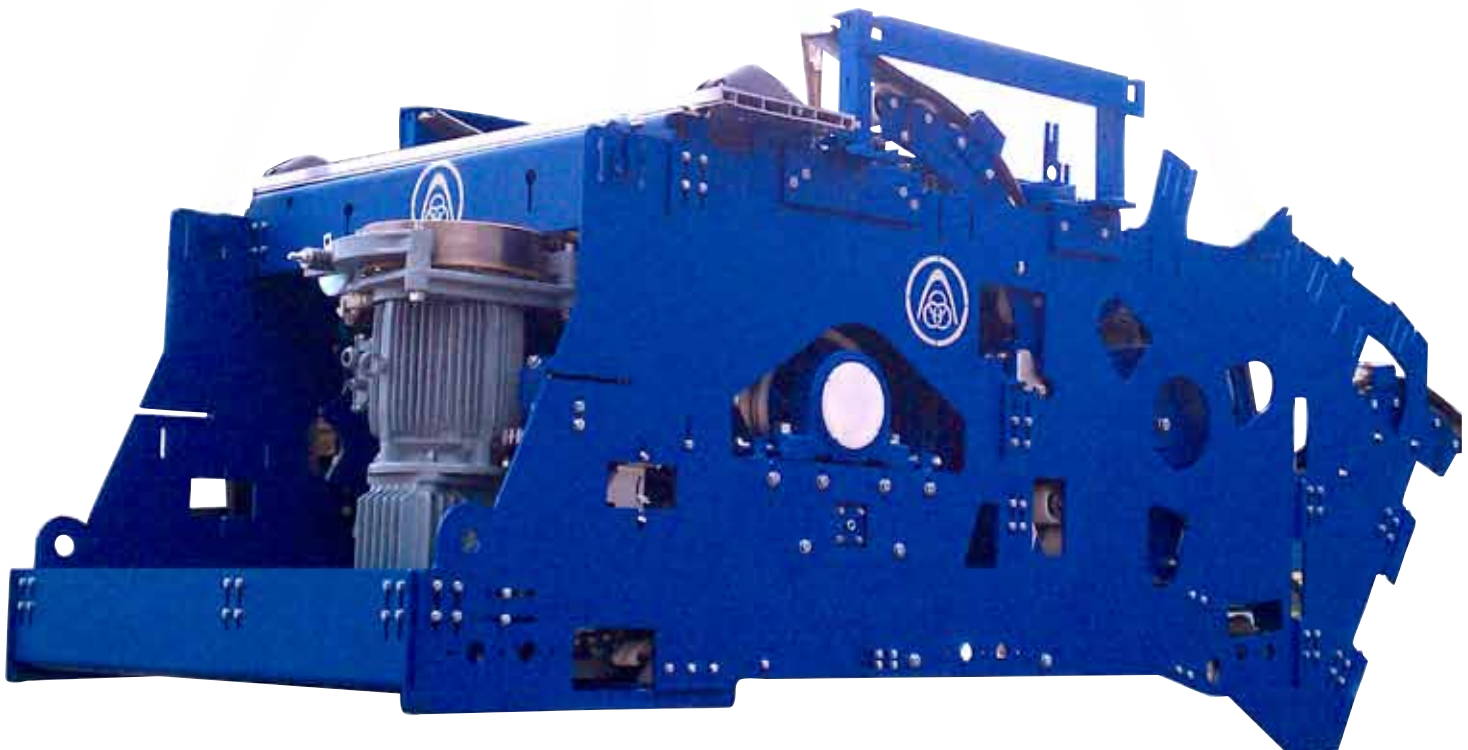

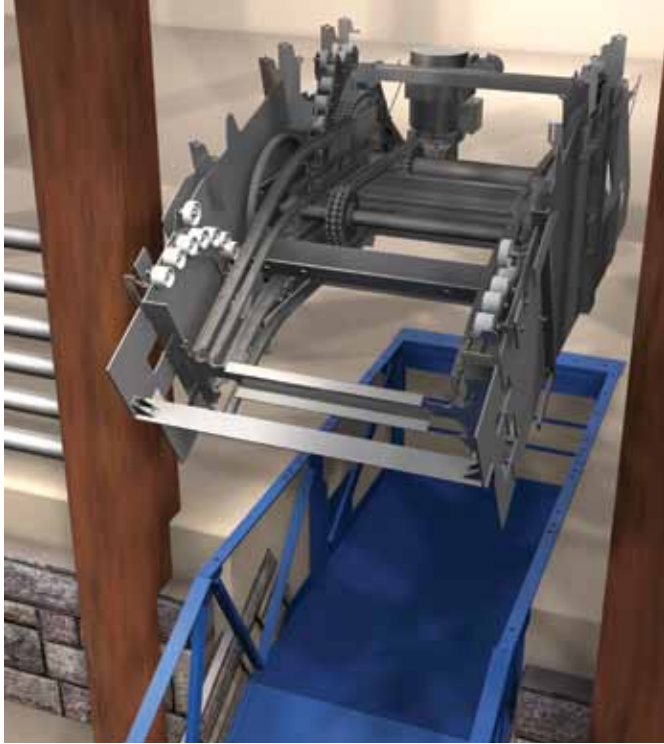

Upper Module

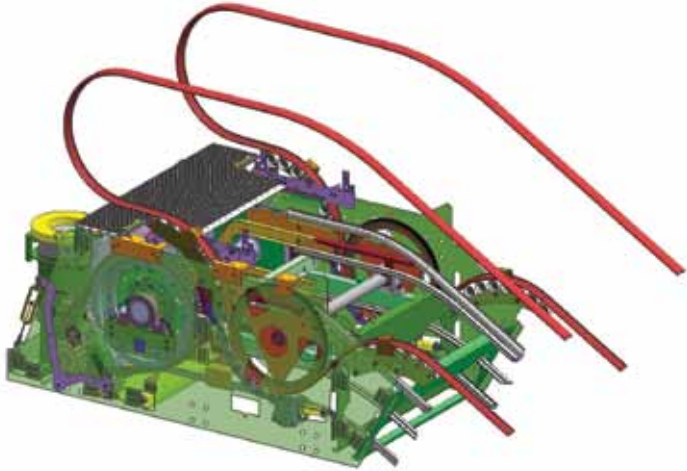

Lower Module

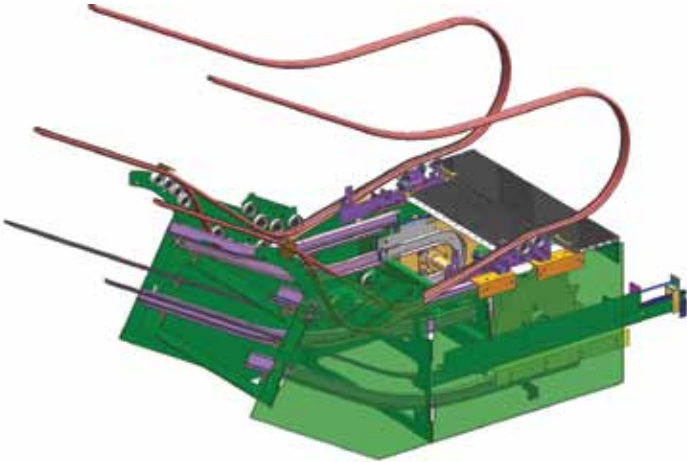

Note: All dimensions in parentheses are in millimeters unless otherwise indicated. Dimensional data shown here comply with the current ASME A17.1 and CSA B44 Safety Code for Elevators. Local codes may vary from the national codes. Consult your local ThyssenKrupp Elevator representative for details.

Escalator and Moving Walk Options

Skirt variants - available in black carbon steel:

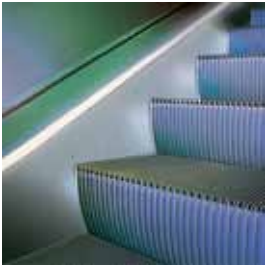

Anti-friction coated skirts with skirt-band lighting.

Extremely durable:

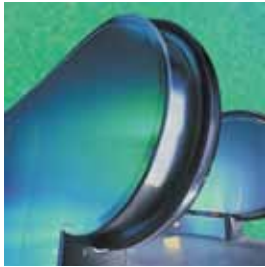

The robust high deck, metal balustrade can take almost anything.

Skirt brushes:



Factory-installed skirt brushes keep passengers at a safe distance.

Visual:

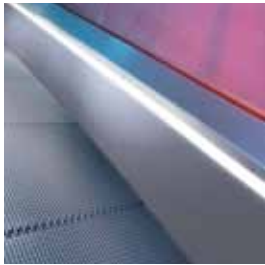

The optional skirt-band lighting provides a continuous line of illumination. LED lighting is available.

Reduced to essentials:

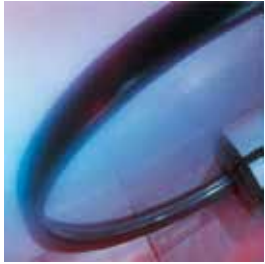

The Orinoco moving walk newel.

Increased durability:



Optional handrail profile provides extra stability and strength.

Outer cladding variants:



Stainless steel

Floor plates:



Aluminum black ribbed

Skirt decking profiles:

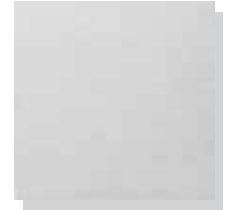

Brushed stainless steel



Mirror



Aluminum plain ribbed



Aluminum



Glass



Stainless steel structure-etched

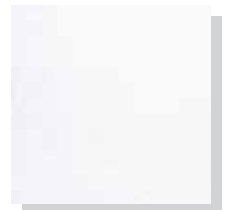

Powder coated

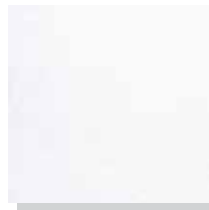

Powder coating



Aluminum checker plate



Anodized silver

Step & Pallet variants:



Powder coated silver with yellow demarcation as required by ASME/ANSI/CSA codes.

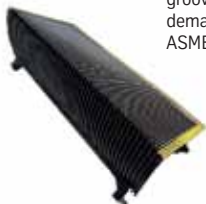

Powder coated black grooves with yellow demarcation as required by ASME/ANSI/CSA codes.

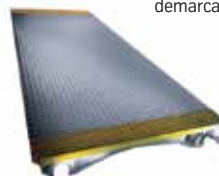

Powder coated silver with optional yellow demarcation.



Powder coated black grooves with optional yellow demarcation.

Note: All dimensions in parentheses are in millimeters unless otherwise indicated. Dimensional data shown here comply with the current ASME A17.1 and CSA B44 Safety Code for Elevators. Local codes may vary from the national codes. Consult your local ThyssenKrupp Elevator representative for details.

1. Travel speeds and transport capacities

Escalators and moving walks can continuously move passengers. Consequently, their transport capacity is much greater than that of elevators.

Travel speed of escalators is limited by code to 100 f/m (0.5 m/s). For moving walks with 0-8 degree inclination, the speed can be increased up to 180 f/m (0.9 m/s).

The chart illustrates the discrepancy between theory and practice: The theoretical transport capacity is useful during the selection procedure. In practice, only approximately 80% of this figure is achieved.

For example, passengers tend to be hesitant at higher rises and higher speeds when stepping onto the step or pallet band. Even with larger step or pallet widths, the possibility to pass is not always utilized. Even so, higher speeds and wider steps or pallets, ensure travel comfort and a considerable reduction of travel time.

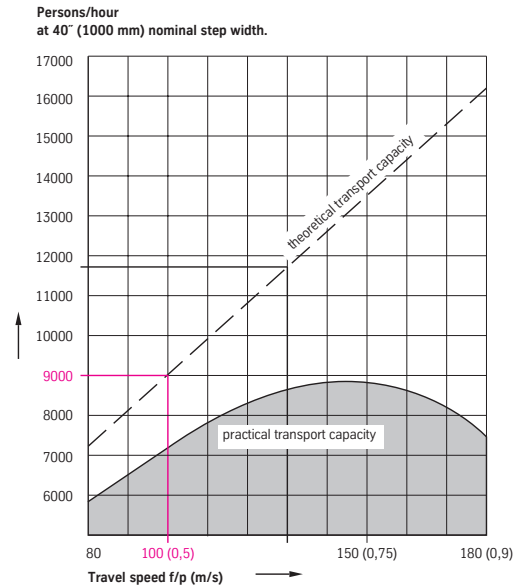

2. Travel heights and inclinations.

Escalators

With a rise of only 6'-0" (1829), an escalator can considerably improve access to the building for the visitor. Furthermore, ThyssenKrupp Elevator has designed escalators to reach a rise of 164'-0" (50 m). Code limits the inclination angle to 30° in the US and Canada.

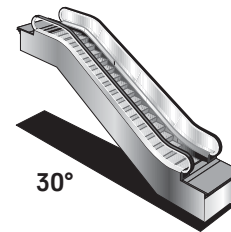

Moving Walks

Inclined moving walks typically used in shopping center and retail applications are permitted a maximum angle of 12°. For extended travel distances, e.g. trade fairs and airports, horizontal moving walks which enable the use of wider pallets are the most efficient option.

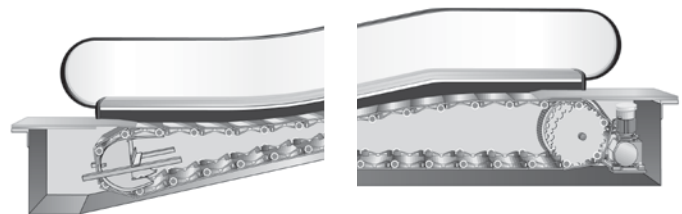

3. Step and pallet widths.

An optimum choice needs to be made here: Neither excessively wide nor narrow steps or pallets represent a balanced ratio between the space required and the transport capacity, between travel comfort and cost.

Based on the cross-sections, you can see the required space of your escalators and moving walks. A clearance of 1 1/4" (30mm) for installation must be added to the dimensions on either side of the escalator or moving walk. The standard escalator step width for the North American market is 40" (1000 mm).

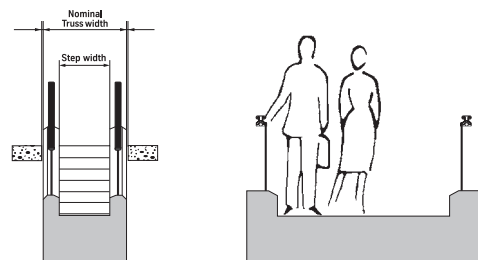

Escalators:

Code Reference for North America: Latest ANSI A17.1/CSA-B44.
EN115 available for other jurisdictions.

Inclination and rise.

	VELINO	TUGELA	VICTORIA
Angle of inclination	30°	30°	30°
Rise	Up to 33'-0" (10.05 m)	Up to 65'-7" (20 m)	Up to 164'-0" (50 m)

Theoretical transport capacities and dimensions for all escalators.

Nominal Step Width	Truss Width	Pit Width	Persons per hour (theoretical)
			100 f/m (0.5 m/s)
24" (600 mm)	3' - 8 1/4" (1124 mm)	3' - 10" (1168 mm)	4500
32" (800 mm)	4' - 4 3/8" (1330 mm)	4' - 6 3/4" (1391 mm)	6750
40" (1000 mm)	5' - 1/4" (1530 mm)	5' - 2 5/8" (1591 mm)	9000

Moving Walks:

Inclination and rise.

ORINOCO FS 982/983	
Angle of inclination	0-6°, 10°, 12° (Max.)
Length	Up to 656'-2" (200 m)
Rise (12°)	Up to 29'-7" (9 m) ¹

Theoretical transport capacities and dimensions for all moving walks.

Nominal Pallet Width	Truss Width	Pit Width	Persons per hour (theoretical)	Persons per hour (theoretical)
			100 f/m (0.5 m/s)	125 f/m (0.65 m/s)
32" (800 mm)	4' - 4 1/4" (1337 mm)	4' - 6 3/4" (1391 mm)	6750	8775
40" (1000 mm)	5' - 1/4" (1530 mm)	5' - 2 5/8" (1591 mm)	9000 or 900	11700
48" (1200 mm)	5' - 8 1/4" (1734 mm)	5' - 10 5/8" (1794 mm)	11250 or 900	14625
56" (1400 mm)	6' - 4 1/4" (1937 mm)	6' - 6 5/8" (1997 mm)	13500 or 900	17550
64" (1600 mm)	7' - 1/4" (2140 mm)	7' - 2 5/8" (2200 mm)	15750 or 900	20475

Greater transport lengths or rises on request

Note: A maximum inclination of 12° is permitted for moving walks. If the pallet width exceeds 40" (1000 mm), a maximum inclination of 4° is permitted by code.

Note: For moving walks with 0° inclination, a maximum pallet width of 64" (1600 mm) is permitted.

1. Safety zone.

The entry and exit zone shall be kept clear of all obstacles. The width of the zone shall be not less than the width between the centerlines of the handrail plus 8" (200 mm). The length of the zone, measured from the end of the newel, shall be no less than twice the distance between the centerlines of the handrail. Space shall be provided to accommodate all traffic in the safety zone.

Note: These dimensions are absolute minimums.

STEP WIDTH	SAFETY ZONE WIDTH	SAFETY ZONE LENGTH
24" Step Width	3' - 5"	5' - 6"
32" Step Width	4' - 1"	6' - 10"
40" Step Width	4' - 9"	8' - 2"

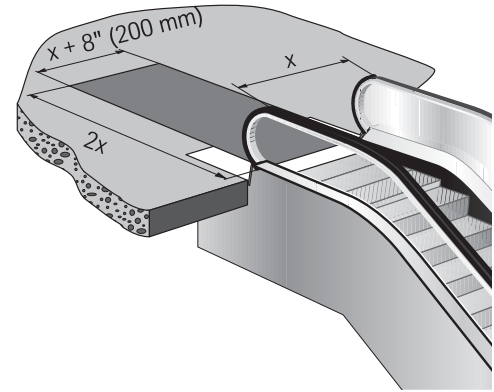

2. Additional deck barricade.

The use of a railing or an additional deck barricade located at a height of 35" (900 mm) prevents people from getting onto the escalator or moving walk from the outside of the balustrades, when outer decking exceeds 5" (127 mm), "Supplied by others".

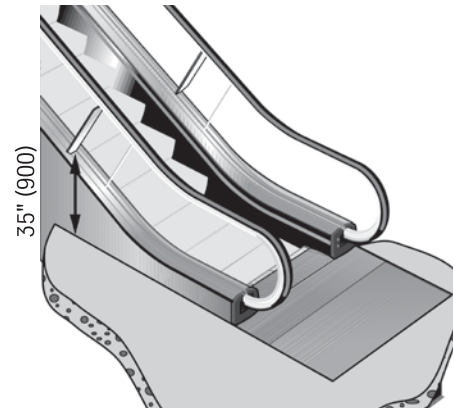

3. Infill panels.

With parallel escalators or moving walks, the maximum distance between the balustrades can be 4" (100 mm). With a larger distance, an infill panel is required.

Note: According to the diagram, an infill panel must be installed, "Supplied by others".

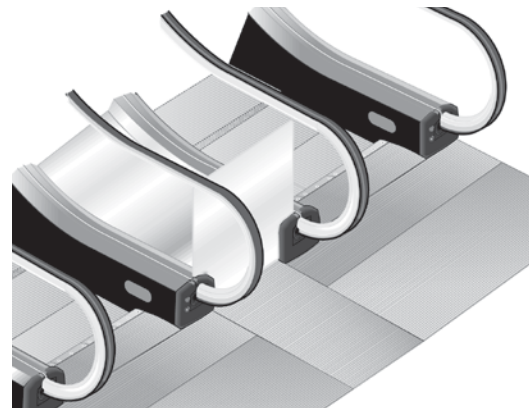

4. Skirt brushes.

Skirt brushes are intended to prevent passenger foot entrapment within the step/skirt running clearance. Factory-installed skirt brushes are featured on all ThyssenKrupp Elevator's escalators.

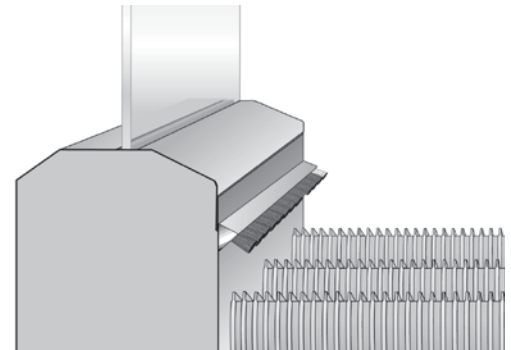

5. Clear height above steps.

The clearance above the step or pallet band must be at least 7' - 0" (2134 mm) at every location as required by code.

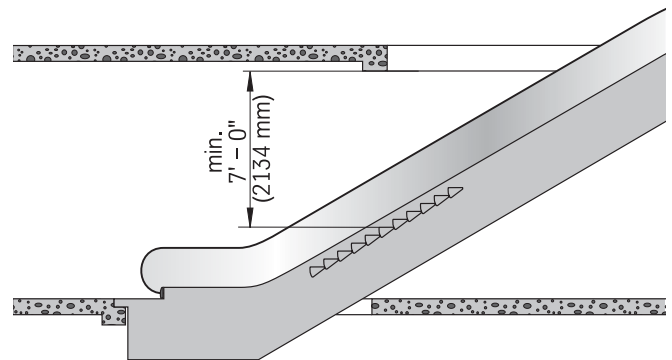

6. Lighting.

In order for passengers to step safely onto escalators, the step or pallet band must be adequately lit. The ambient building lighting must be at least 50 Lux along all parts of the step band. ThyssenKrupp additionally offers various additional lighting options.

For example:

1. Above the balustrade (under handrail)
2. Integrated in the skirt band (skirt lighting)
3. At the comb-plates (combplate lighting)

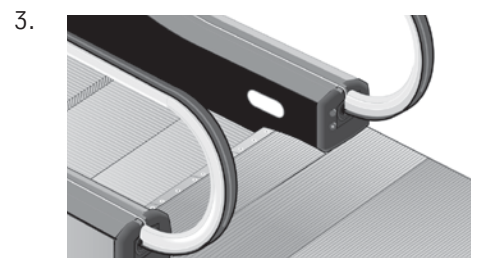
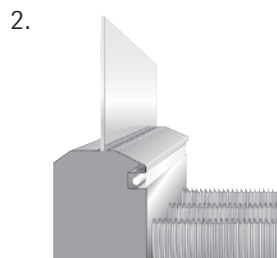
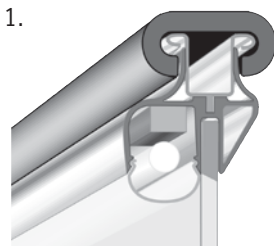

Planning for Perfection Installation Possibilities

Examples showing arrangements.

There are various possibilities for positioning escalators in a building. Shown are several examples of the most frequently used arrangements. Depending on the requirement, you can decide whether passengers are to be conveyed quickly from floor to floor or whether they may be led through promotional areas.

ThyssenKrupp escalators are designed so that they can be operated in both directions. That is why at the planning stage, you do not need to decide the direction of travel.

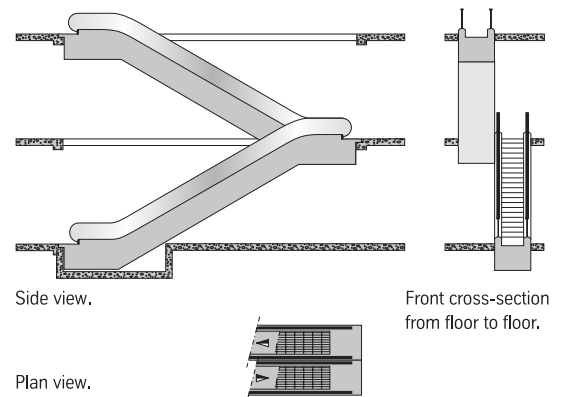
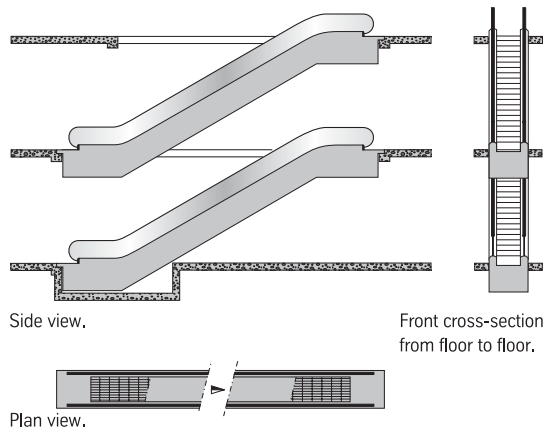

Escalator in one direction of travel (route interrupted): With this arrangement, the passengers are guided past promotional areas. To go from one floor to the next, they are forced to walk back along the side of the escalator.

Escalators in one direction of travel (continuous): Quickly and easily, the passengers move from floor to floor through short changeover paths.

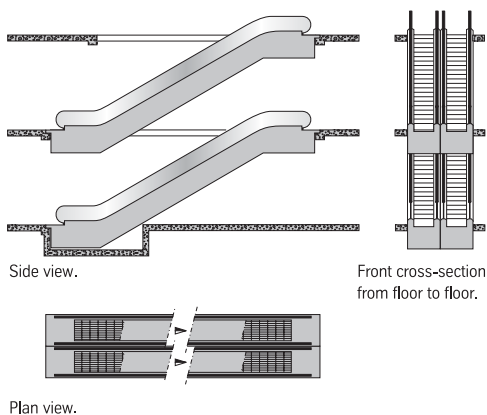

Escalators for both directions of travel: This arrangement is characterized by increased travel comfort for the customers, since escalators are available for the upward and downward direction. The promotional areas on both sides of the escalators are given greater attention.

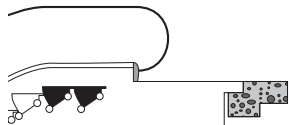

Standard 2 - Flat Step Configuration

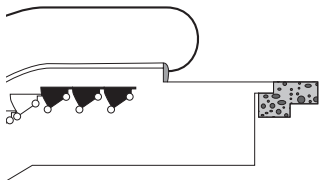

Optional 3 - Flat Step Configuration Used typically for rises greater than 25' - 0" (7620 mm).

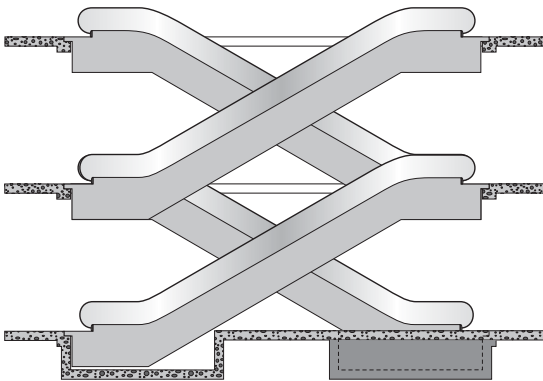

Side view.

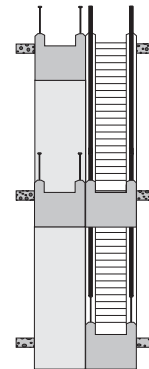

Front cross-section from floor to floor.

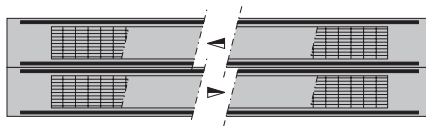

Plan view.

Criss-cross arrangement: The passengers can get to and from the upper floors quickly and easily through short changeover paths.

Moving Walks:

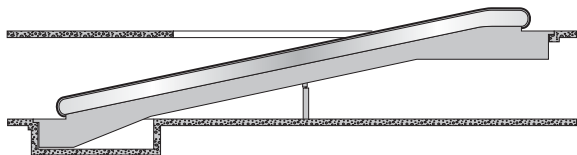

Side view.



Plan view.

Inclined moving walks in parallel.

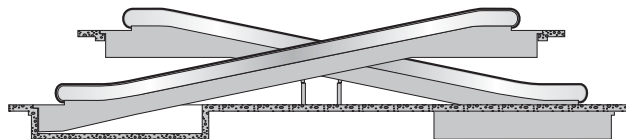

Side view.



Plan view.

Criss-cross arrangement: Moving walks with top and bottom transition curve in criss-cross arrangement.



Side view.

Horizontal moving walk.



Side view.

Ramped horizontal moving walks: Where no continuous pit is possible. The inclination of the ramp can be up to 12° [maximum 4° when pallet width exceeds 40" (1000 mm)].

Additional notes:

- ❖ Upper well ventilation is not required for escalators and moving walks.
- ❖ A lower pit-floor cut-out is required to house the oil-water separator for outdoor applications.

Note: All dimensions in parentheses are in millimeters unless otherwise indicated. Dimensional data shown here comply with the current ASME A17.1 and CSA B44 Safety Code for Elevators. Local codes may vary from the national codes. Consult your local ThyssenKrupp Elevator representative for details.

Planning for Perfection Preparations by Others

Perfect planning also includes optimum installation planning. That is why on the following pages we have listed everything that needs to be planned and carried out on site, to ensure easy installation of your escalators and moving walks.

This is especially true in existing, occupied buildings where the escalator or moving walk needs to be replaced. ThyssenKrupp is the industry leader in the removal and replacement of escalators and moving walks. With our experience, we will provide a time-saving removal or replacement strategy combined with a custom truss design to suit the existing well way, reducing inconvenience for tenants and building traffic flow.

1. Installation timing.

Whenever possible, schedule escalator delivery to take place prior to the installation of subsequent floor slabs, ceilings, roofs and any other overhead obstructions.

2. Access openings, transport route load capacity.

Normally, escalators / moving walks are moved in by crane through a suitable overhead opening. In most cases, this allows the equipment to be assembled off-site, in turn removing the manpower, material crates and disruption from the way of other subcontractors. Another option is to bring the escalator / moving walk in through a suitable opening at the ground floor. It is important that the route to the assembly location within the building is free of obstacles and level, and the ceiling can support the hoist load. Otherwise, appropriate shoring must be provided.



Minimum building access opening of 11'-6" (3.5 m) x 11'-6" (3.5 m).

An escalator [e.g. with a travel height of 17'-6" (5.3 m)], at an angle of 30°, weighs approximately 18,000 lb (8165 kg). Therefore please check that the floor of the building will bear the transport weight of your escalator. Otherwise, additional floor under-pinning support will be required during the installation period.

Completely assembled escalator. Dimensions To Be Confirmed.

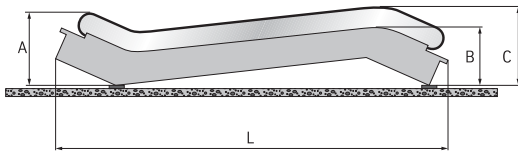

Transport length L
Transport height A: with balustrade
B: with balustrade removed
C: balustrade only removed from the upper section

Split escalator. Dimensions To Be Confirmed.

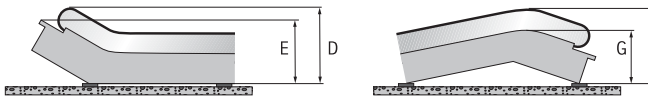

Transport height D: with balustrade
E: without balustrade
F: with balustrade



3. Special delivery.

In order to deliver your system into the building and to assemble it ready for use in a timely manner, take note of the following during the planning stage:

- ❖ In most cases it is not possible to bring the complete escalator / moving walk into the building. In this case we dismantle the balustrades before delivering the escalators / moving walks.
- ❖ Some escalators / moving walks are so long that they have to be installed in sections. In this case, we manufacture a split escalator / moving walk at the factory and joins the truss sections together on site.

4. Overhead openings.

We will notify you of the location and size of the required ceiling/roof openings. Please ensure the required opening dimensions are made available.

5. Top and bottom supports. (Seismic zones vary)

When you design the support recesses please take into account the support loads. They are shown on the installation drawing, i.e. at those locations where the supports of your escalator (or your moving walk) will be placed, the supports must be able to bear the weight of the escalator including 105lbs/ft² traffic load. When preparing the supporting structures, the dimensions and reactions indicated on our installation plans must be precisely adhered to.

Side view through the support with details (Non-Seismic)

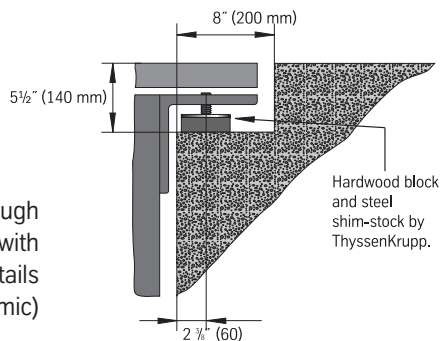

Note: All dimensions in parentheses are in millimeters unless otherwise indicated. Dimensional data shown here comply with the current ASME A17.1 and CSA B44 Safety Code for Elevators. Local codes may vary from the national codes. Consult your local ThyssenKrupp Elevator representative for details.

6. Intermediate supports.

Intermediate supports are needed on escalators with a considerable travel height and on long moving walks. We will inform you if an intermediate support is required and will assist with determination of its location.

Typically, an intermediate support is required:

- 2 flat steps design: $H > 26'-6"$ (8077 mm)
- 3 flat steps design: $H > 24'-10"$ (7569 mm)

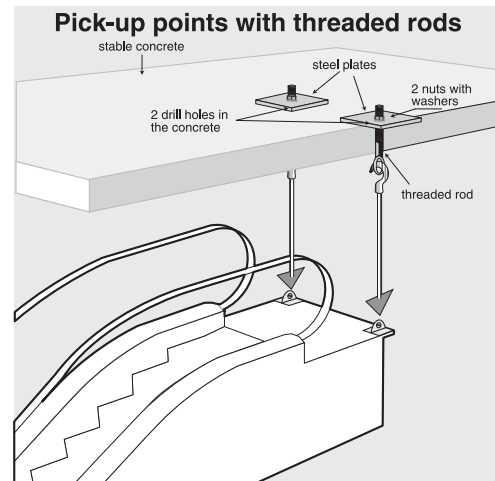
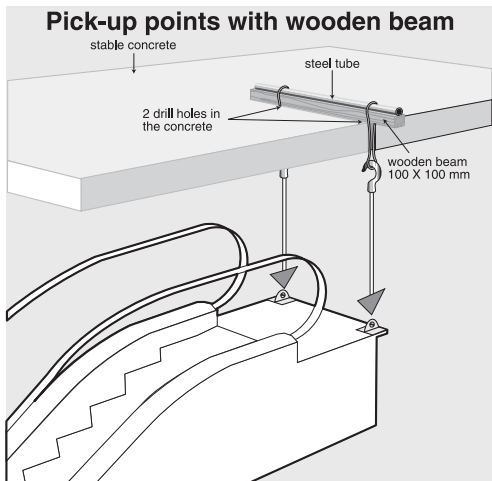
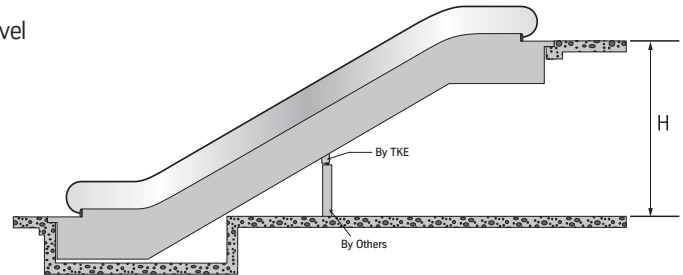

7. Pick-up points by others.

You will be responsible for fitting pick-up points for hoisting and supporting the escalator during assembly. Speak to your local TKE representative for size and location. These should be located exactly above the center of the supporting points. For systems with several supporting structures please plan for additional pick-up points above the intermediate supports. All pick-up points must be capable of taking a load strain of 11,240 lb (50 KN).

8. Truss cladding.

The exterior cladding of the truss (unless otherwise specified) is by others. Weight of cladding not to exceed 10 lb/ft² (48.82 kgf/m²).

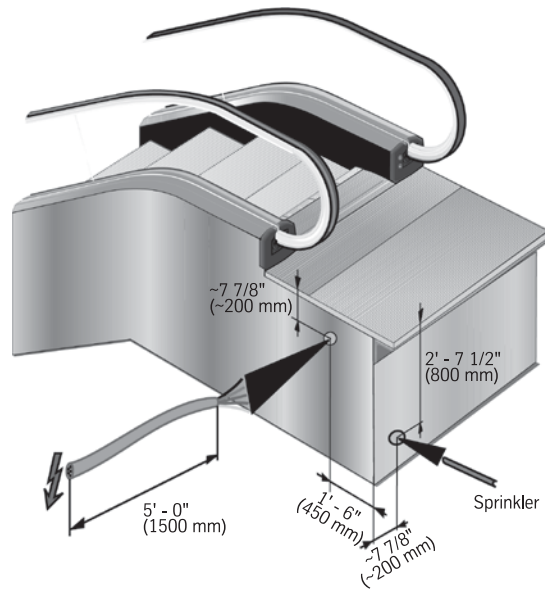

9. Electrical connection.

Our diagram shows where escalators and moving walks are connected to the power supply. Power supply is always located at the upper well. Please note that electrical cables are inserted at a distance of 1'-6" (450 mm) on the side of the support and that the length of the cable on the inside of the escalator must be about 5'-0" (1500 mm). With complex controls, such as those usually required for escalators and moving walks in transit installations, the escalator control equipment may be installed in a separate room. The power supply cable must be installed in this separate control room. In case of additional soffit lighting, a separate power supply must be provided in time. The power connection must be provided by an authorized electrician assigned by the owner's representative.

In the case where escalator truss or comb plate heaters are provided, a separate 220 VAC power supply is required.

10. Sprinkler piping.

An optional safety feature is the installation of a sprinkler piping within the escalator or moving walk.

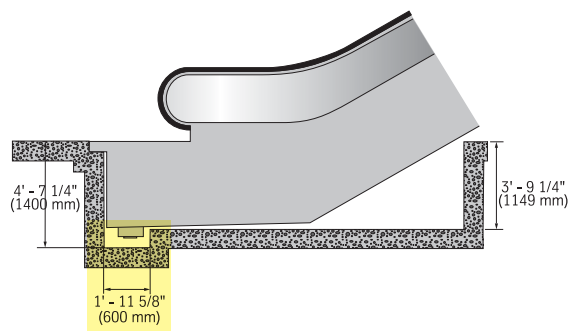

11. Oil/Water separator.

A type-proofed oil/water separator is essential for escalators and moving walks which are designed for outdoor exposure. ThyssenKrupp supplies an oil/water separator in the lower well for all outdoor-exposure products. At the construction site, a recess and drain must be provided for the oil separator in the pit.

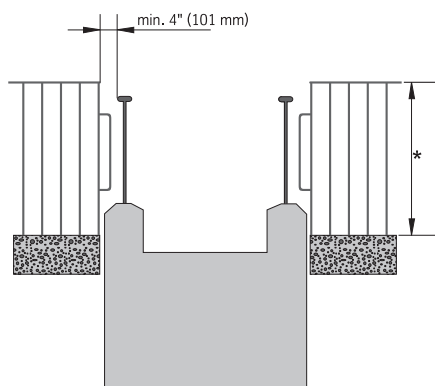

12. Railing by others.

In the threshold areas of the escalators, a railing must be installed by others. The distance to the escalator handrail must be at least 4" (101 mm).

* **Ornamental protective handrail by others, height determined by local code. Typically: 42" (1067mm)**

Escalator and Moving Walk Section and Plan Views

Escalator Section View, 30°, 2 flat step configuration

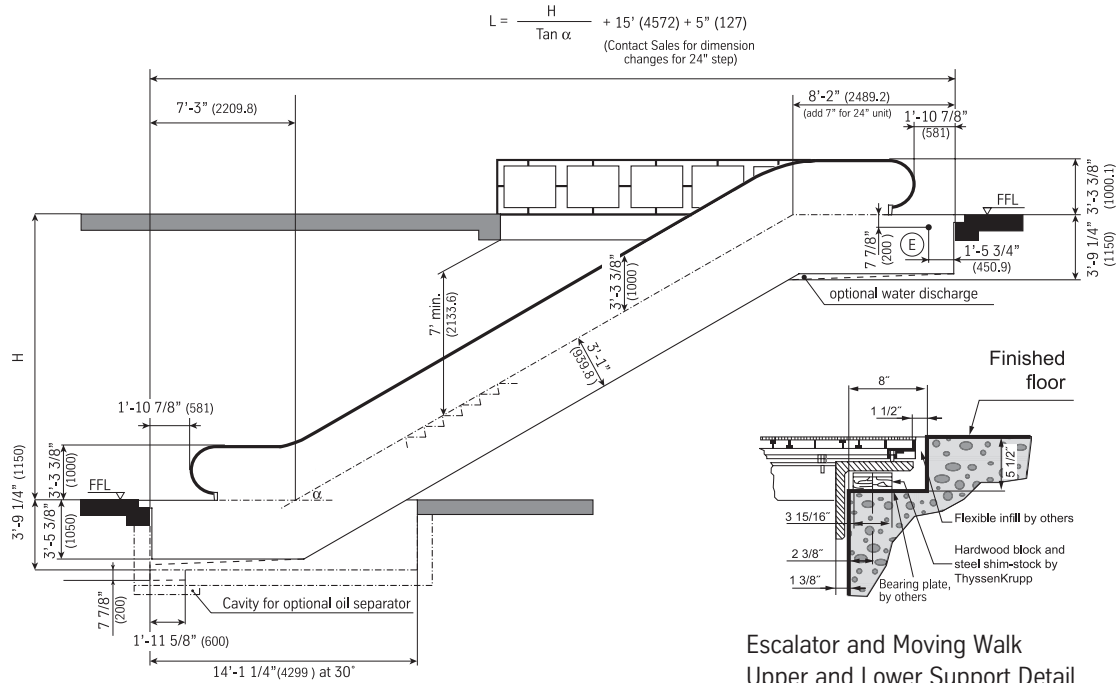

Escalator/Moving Walk Plan View



Escalator Dimensions

K	L	M	N
24"	3' - 8 1/4"	7' - 7"	2' - 9"
32"	4' - 4 1/4"	8' - 11"	3' - 5"
40"	5' - 0 1/4"	10' - 3"	4' - 1"

Moving Walk Dimensions

K	L	M	N	A	B	C
40"	5' - 0 1/4"	10' - 3"	4' - 1"	< 39' - 8"	< 39' - 8"	< 39' - 8"
48"	5' - 8 1/4"	11' - 7"	4' - 9"	< 42' - 3"	< 42' - 3"	< 42' - 3"
56"	6' - 4 1/4"	12' - 11"	5' - 5"	< 45' - 3"	< 45' - 3"	< 45' - 3"
64"	7' - 1/4"	14' - 3"	6' - 1"	< 48' - 3"	< 48' - 3"	< 48' - 3"

Moving Walk Section View

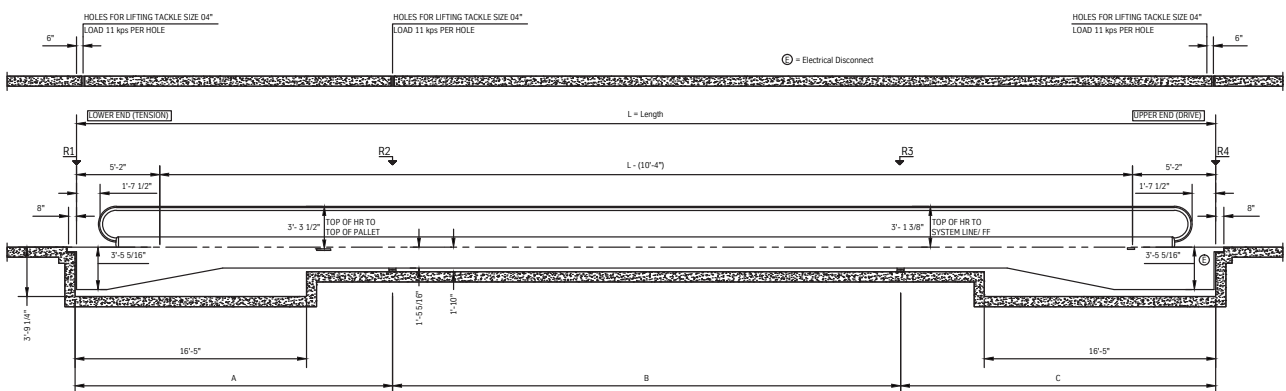

Note: All dimensions in parentheses are in millimeters unless otherwise indicated. Dimensional data shown here comply with the current ASME A17.1 and CSA B44 Safety Code for Elevators. Local codes may vary from the national codes. Consult your local ThyssenKrupp Elevator representative for details.

Work by others: Escalators and Moving Walks

Escalators

- A. Provision of proper building dimensions and suitable floor openings, properly framed with suitable reactions and finished in accordance with escalator shop drawings. Variations not to exceed +1"-0" at any point.
- B. Supporting structure for the escalators and enclosure walls, external railing, guards, closures, shutters and smoke barriers as required.
- C. Waterproof lower well space and provide lower pit drainage (as required).
- D. Fire-rated exterior cladding of truss and finish from the edges of escalator deck covers, including ends, sides and bottom of truss in accordance with applicable and standard weight restrictions. (max. 10 lbs. per square foot)
- E. Access panels or doors to interior of escalator if required by unusual layout conditions.
- F. Provision of flexible in-fill and finished flooring adjacent to floor plates and escalator after installation.
- G. Cutting of floors, walls, ceilings or partitions together with any repairs made necessary by such cutting.
- H. Painting and finish work required beyond that included in this section.
- I. Electrical service to upper well including 3 phase main power supply and lockable, fused disconnects to each controller. Provide single phase 120 VAC electrical service and lockable, fused disconnect for light and convenience outlet in the upper well and all other electrical devices that are not a part of the escalator proper but may be required by local authorities. Separate 220V AC to be supplied with lockable, fused disconnect for truss and/or comb plate heating when required.
- J. Provision of wiring and conduit from the closest wellway of each escalator group or single escalator to the firefighter's control room and/or console as required. Coordinate with escalator contractor for size, number and location of conduit.
- K. Other work required for installation of the escalator(s) including, but not limited to, required changes to sprinklers, lighting, electrical, air conditioning and heating systems. Provide barriers for open wellways during construction per OSHA regulations.
- L. Protect escalator truss, steps, landing plates, balustrades, handrail, and special metal finishes from damage during construction.

Moving Walks

- A. Provision of proper building dimensions and suitable floor openings, properly framed with suitable reactions and finished in accordance with moving walk shop drawings. Variations not to exceed +1"-0" at any point.
- B. Supporting structure for the moving walks and enclosure walls, external railing, guards, closures, shutters and smoke barriers as required.
- C. Waterproof lower well space and provide lower pit drainage (as required).
- D. Fire-rated exterior cladding of truss and finish from the edges of moving walk deck covers, including ends, sides and bottom of truss in accordance with applicable and standard weight restrictions. (max. 10 lbs. per square foot)
- E. Access panels or doors to interior of moving walk if required by unusual layout conditions.
- F. Provision of flexible in-fill and finished flooring adjacent to floor plates and moving walk after installation.
- G. Cutting of floors, walls, ceilings or partitions together with any repairs made necessary by such cutting.
- H. Painting and finish work required beyond that included in this section.
- I. Electrical service to upper well including 3 phase main power supply and lockable, fused disconnects to each controller. Provide single phase 120 VAC electrical service and lockable, fused disconnect for light and convenience outlet in the upper well and all other electrical devices that are not a part of the moving walk proper that may be required by local authorities.
- J. Provision of wiring and conduit from the closest wellway of each moving walk group or single moving walk to the firefighter's control room and/or console as required. Coordinate with moving walk contractor for size, number and location of conduit.
- K. Other work required for installation of the moving walk(s) including, but not limited to, required changes to sprinklers, lighting, electrical, air conditioning and heating systems. Provide barriers for open wellways during construction per OSHA regulations.
- L. Protect moving walk truss, steps, landing plates, balustrades, handrail, and special metal finishes from damage during construction.
- M. All engineering costs to determine and identify structural load capacities and restrictions will be by others.

ThyssenKrupp Elevator

P.O. Box 2177, Memphis, TN 38101

Phone (877) 230-0303

thyssenkruppelevator.com | version 01.11

All illustrations and specifications are based on information in effect at time of publication approval. ThyssenKrupp Elevator reserves the right to change specifications or design and to discontinue items without prior notice or obligation. Copyright © 2011 ThyssenKrupp Elevator Corporation.

