

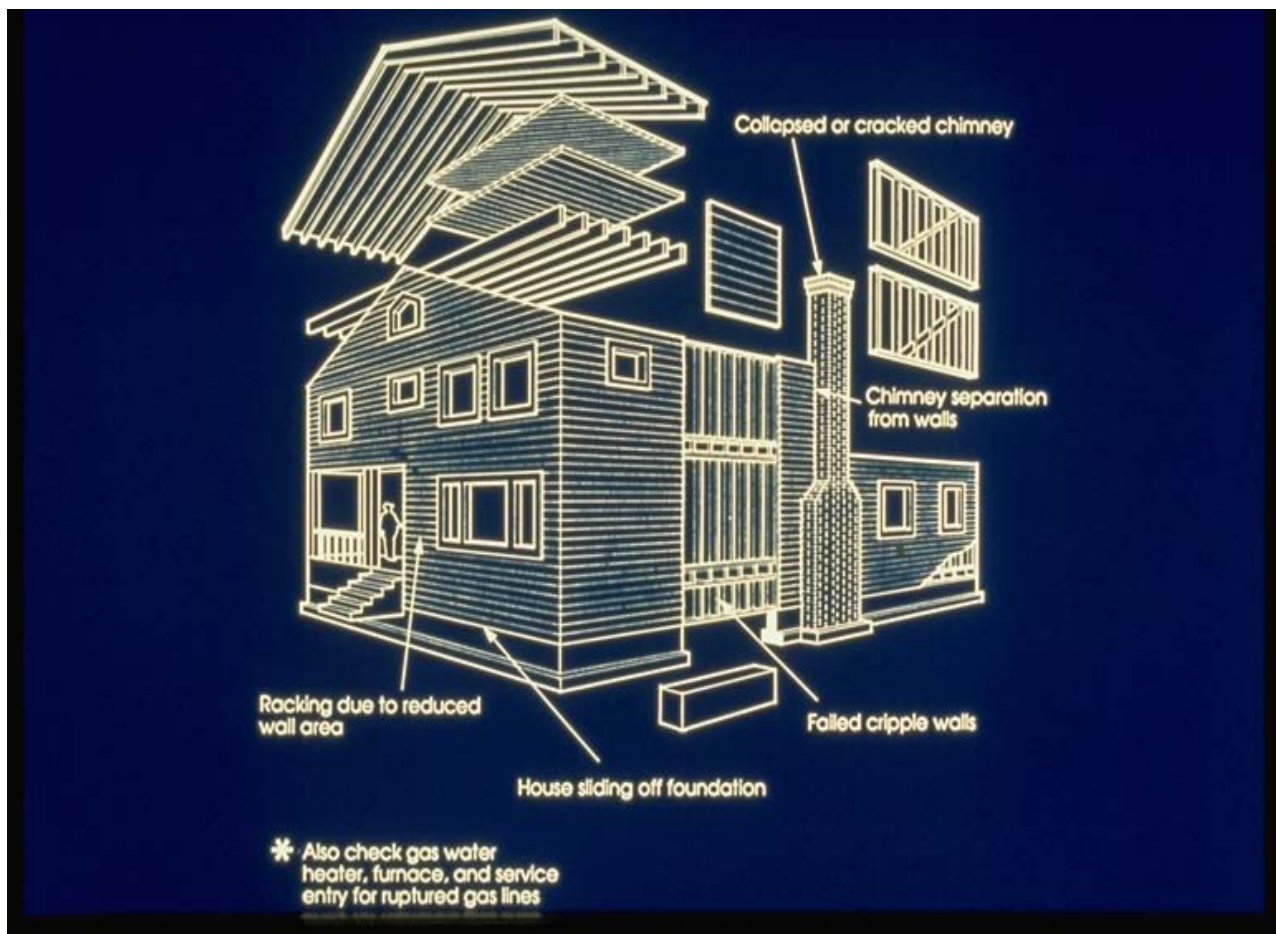

EARTHQUAKE HOME RETROFIT HANDBOOK

HOW TO COMPLETE AN EARTHQUAKE RETROFIT PLAN FOR WOOD-FRAME RESIDENTIAL BUILDINGS



SECTION 3 - TABLE OF CONTENTS

INTRODUCTION	1
PURPOSE OF THE GUIDE TO COMPLETING AN EARTHQUAKE RETROFIT PLAN FOR WOOD FRAME RESIDENTIAL BUILDINGS	1
Standard Earthquake Home Retrofit (SEHR) Planset Format	3
Does your home qualify to use the Standard Earthquake Home Retrofit (SEHR) Planset?	3
What if your home does not qualify?	3
Do I Need A Building Permit?	3
How Many Copies of my Plan Must Be Submitted to Obtain A Building Permit?	4
HOW TO COMPLETE YOUR EARTHQUAKE RETROFIT PLAN	5
SUMMARY OF RETROFIT TASKS	5
DETAILED TASK DESCRIPTIONS	8
Task 1. Drawing the foundation outline	8
Task 2 Replacing sections of damaged concrete foundation wall	10
Task 3. Anchoring the sillplate to the foundation wall	11
Task 4. Bracing the pony walls	17
Task 5. Connecting the floor framing system to the pony wall or foundation wall	23
REVIEW OF THE STEPS FOR COMPLETING AN EARTHQUAKE RETROFIT PLAN	26
OBTAINING A BUILDING PERMIT AND FINISHING THE PROJECT	27
Building Permit Issuance	27
Beginning Work	27
Required Inspections	27
Additional Inspections	27
APPENDIX A: DEFINITIONS OF COMMON CONSTRUCTION TERMS	28
APPENDIX B: BASIC CONCEPTS FOR EARTHQUAKE RESISTANT DESIGN	29
APPENDIX E: NAIL SIZES	49

FIGURES

Figure 1 Side view of a typical retrofit wall section. Numbers refer to the drawings on the SEHR Planset	6
Figure 2 Isometric view of a typical retrofit, showing foundation anchor bolts, pony wall bracing, and framing clips, from inside the basement or crawlspace.	7
Figure 3 Sample rough sketch of foundation outline (view from above)	8
Figure 4 Installing anchor bolts through the sill plate and into the foundation, using a rotohammer.	12
Figure 5 Sample manufacturers sheet for anchor side plates.	13
Figure 6 Mechanical anchor bolt for connecting the sill plate to the foundation wall.	15
Figure 7 Illustration of the movement of a sample wall section in response to earthquake shaking, called side-sway.	17
Figure 8 Pony wall failure after the 1994 Northridge Earthquake from excessive side sway.	17
Figure 9 Pony wall without structural panels to strengthen the wall to resist excessive side-sway	18
Figure 10 Installing structural panels on all perimeter walls helps prevent the walls from collapsing, keeping the house on its foundation	18
Figure 11 How to cut out a section of structural panel to accommodate piping, etc.	20
Figure 12 An example of overdriven nails. Nails should be driven flush with the surface of the structural panel.	22
Figure 13 Illustration of a framing clip installed between the floor framing system and the underlying sill plate showing the applied load generated by the force of the earthquake along the clip's long direction.	24

Disclaimer

The information in the Earthquake Home Retrofit Handbook is based on current practice and standards for the retrofit of existing buildings. Practice and standards may change as new information is learned. No guarantee is made that the use of the information in the series will prevent all losses in all earthquakes. Liability for any losses caused by earthquakes or as a result of applying the information in these publications is specifically disclaimed.

Introduction

Purpose of The Guide to Completing an Earthquake Retrofit Plan for Wood Frame Residential Buildings

This booklet gives you step-by-step instructions for an earthquake retrofit project with the Standard Earthquake Home Retrofit (SEHR) Planset. Damage to homes in the 1994 California Northridge Earthquake show that incorrect or incomplete retrofits are “as bad as having no retrofit at all” (FEMA Seismic Retrofit Training Handbook 1998). To be effective, the earthquake retrofit of your home should at least conform to the minimum prescriptive requirements in the standard plan. Prescriptive means that the information in the plan must be applied in the exact manner described. Table 1 (SEHR Planset, Section III) provides a summary of the minimum prescriptive requirements. Contact your local building department to find out how to obtain copies of the SEHR Planset (or Planset).

The information in this booklet does not teach you how to design an earthquake retrofit, but it does explain how to apply the Planset’s simplified construction methods to complete your retrofit project and to select construction materials according to the plan’s minimum prescriptive requirements. Not all details in the SEHR Planset will work for your building, so you will need to select the details applicable to the framing system of your specific building.

Retrofitting your home according to the minimum prescriptive requirements in the SEHR Planset will reduce the likelihood that the building will shift on its foundation, but structural retrofitting will not necessarily prevent all earthquake damage.

Steps for Completing an Earthquake Retrofit Plan

First complete the Home Assessment Checklist to determine if your home qualifies to use the SEHR Planset and to identify the general type of retrofit work that must be done before developing a detailed earthquake retrofit plan for your home retrofit project. This is explained in detail in Chapter 2, and the Checklist can be found on the Planset.

You will then use the rest of this guide to

- (1) Draw your Earthquake Retrofit Plan Drawing in the space provided on the SEHR Planset in the permit application packet and mark the scale used.
- (2) Select the Drawing Details reference numbers and the structural panel layout and mark them on your foundation outline.
- (3) Make a note about the materials you will use to implement each drawing detail.

Your completed earthquake retrofit plan drawing will address all of the following elements in the standard plan **that apply to your building’s condition:**

- repairing or replacing damaged parts of the foundation
- anchoring the sill plate to the underlying foundation wall with anchor bolts or anchor side plates
- strengthening the pony walls with structural panels
- connecting the floor framing to the underlying sill plate or pony wall using framing clips

This chapter will explain how to follow the "Sample Plan Drawing" shown on the SEHR Planset (Section IIa) as a guide for the preparation of your earthquake retrofit plan. The foundation outline you draw in Task 1 will be annotated with the appropriate information and plan details to address the conditions that exist in the home to be retrofit. If you choose to draw your earthquake retrofit plan on a separate sheet of paper, you will need to transfer it to the space provided on the SEHR Planset.

At that time, you will be ready to submit your completed earthquake retrofit plan to the building department for plan review and processing of your permit.

Obtaining a Building Permit and Finishing the Project

You must have a building permit before you retrofit your home. The permit process ensures that the proposed plan is reviewed and that installation has been performed in accordance with the voluntary minimum prescriptive requirements in the SEHR Planset. The inspection provides you quality control of work performed.

Once you have completed the SEHR Planset, take two copies of both the Planset, the Drawing Details, and the Home Assessment Checklist to the building department. Many copy stores have equipment to copy the larger sized sheets of paper. Department staff will review the Home Assessment Checklist and your Earthquake Retrofit Plan Drawing. They may ask questions about the project to make sure that no critical issues have been overlooked. When the building permit is issued, you will receive an approved copy of your earthquake retrofit planset.

Building Permit Issuance

If your Standard Earthquake Home Retrofit (SEHR) Planset and your attached drawing details are in order, the sheets will be stamped approved and a building permit issued upon payment of the required fees. Fees for an earthquake retrofit project permit are based on the value of the project. Fees vary from one jurisdiction to another, and many have lowered costs for retrofitting. A home that requires additional work to improve poor existing conditions, such as installing a new foundation, may require higher permit fees to cover the more expensive and complex project. An "Inspection Record Card" will be provided for use by the building inspector.

Beginning Work

With the permit in hand, you, the homeowner, may decide to complete the work or you may choose to hire a contractor. As every jurisdiction is different, check with your local building department on the length of time allowed to complete work under your permit.

Required Inspections

Have the project address and the permit number available and let the inspector know if it is for Project Impact-related bolting or pony wall bracing. Building department staff will visit your home to inspect the retrofit work. Generally one inspection will be completed after the anchor bolts are installed and one inspection after the pony wall bracing is installed. The contractor, or you as homeowner if you are doing

the work yourself, is responsible to call your local building department or division inspector when you are ready for these inspections. Inspection will focus on work-related to the earthquake retrofit project.

Additional Inspections

If unusual structural conditions or site problems are uncovered after work begins, and these problems necessitate additional field inspections by the building department, supplemental fees may be assessed to cover the cost of the additional inspections. The building department will advise you beforehand if this need arises.

SEHR Planset Format

Depending on your local jurisdiction, the 2002 SEHR Planset comes in two formats. It is either printed on four (30 x 42) or twenty (11 x 17). The SEHR Planset contains three sections: Section I – The Home Assessment Checklist, Section II - Earthquake Retrofit Plan Drawing (sample and instructions), and Section III - General Notes followed by the Planset Drawing Details. The General Notes section includes a detailed description of retrofit materials and installation requirements as well as a brief summary of the retrofit's purpose, scope, and definition. The Planset Drawing Details provides detailed construction drawings, showing how to carry out the retrofit work. This booklet shows how a homeowner or contractor can use the information on the Planset sheets to complete an earthquake retrofit plan. Space is provided on the Planset (Section IIb) to draw your plan.

Does your home qualify to use the SEHR Planset?

The guidelines and plan details in the SEHR Planset apply to one-, two-, and three-story wood-frame, residential buildings that meet the qualification criteria in the Home Assessment Checklist found on the Planset. The completed checklist must be submitted as part of your building permit application. The Guide for Completing the Home Assessment Checklist (Chapter 2) provides help in using the checklist to determine if your home qualifies to use the SEHR Planset.

What if your home does not qualify?

If your home does not qualify to use the SEHR Planset, alternate earthquake retrofit methods and materials may be used when approved by the building official. You may need to hire a licensed design professional (such as an engineer or architect) to design an alternate earthquake retrofit plan to address your home's specific needs. Your local building department may be able to help you decide if you can use the SEHR Planset or identify resources that can help you make that decision. An example of such a circumstance is that some jurisdictions may still allow a permit for a SEHR Planset when 1 or 2 of the 4 perimeter walls need an engineers stamp.

<p>The retrofit method contained in the SEHR Planset may be inadequate to prevent serious structural damage to homes that do not qualify to use the plan's simplified approach.</p>

Do I Need A Building Permit?

You must get a building permit before you start the work on your earthquake retrofit. Call your local building department for permit information. Use of the Planset should reduce the amount of time needed to obtain a building permit. The intent of the program is to provide an expedited permit process. Review of your home's earthquake retrofit plan by the building department can help identify inappropriate applications of the plan's prescriptive methods. The plan reviewer may be able to suggest alternate solutions or planning resources to assist you.

How Many Copies of My Plan Must Be Submitted to Obtain A Building Permit?

Generally the local building department will require two copies of your completed Standard Earthquake Home Retrofit (SEHR) Planset be submitted, including the completed Home Assessment Checklist.

Your completed SEHR Plansets should include:

- (1) the Earthquake Retrofit Plan Drawing with your specific drawing in the space provided showing a dimensioned outline of your home's foundation wall with the numbers of the drawing details you will use to carry out the work marked on the appropriate location on the outline;
- (2) the Planset pages showing all the drawing details you will use, and any additional drawing details you prepared or had prepared by a design professional to address conditions not covered by the drawings on the SEHR Planset.

How to Complete Your Earthquake Retrofit Plan Drawing

Summary of Retrofit Tasks

Figure 1 and 2 show a typical side and front view, respectively, of a wall strengthened to meet the minimum prescriptive requirements in the SEHR Planset. The numbers marked on Figure 1 refer to the number of the drawing details on the Planset. This booklet helps you determine which of the drawing details on the planset are relevant to your home's retrofit plan.

You will need to complete five tasks to prepare your Earthquake Retrofit Planset.

Task 1. Draw the foundation outline.

Task 2. Select method of replacing sections of damaged concrete foundation wall, if necessary.

Task 3. Select method of anchoring the sill plate to the foundation wall.

Task 4. Select method of strengthening the pony wall.

Task 5. Select method of connecting the floor framing system to the pony wall or to the foundation wall.

You may skip a task only if your home already meets the plan requirement being addressed. Detailed guidance and information for completing each task can be found on pages 7 through 25.

If you use alternate construction methods, you must prepare drawing details showing how the work will be done. You may need a licensed design professional (such as an architect or engineer) to design alternate construction methods. Label each alternate detail to be used and mark the number on your plan.

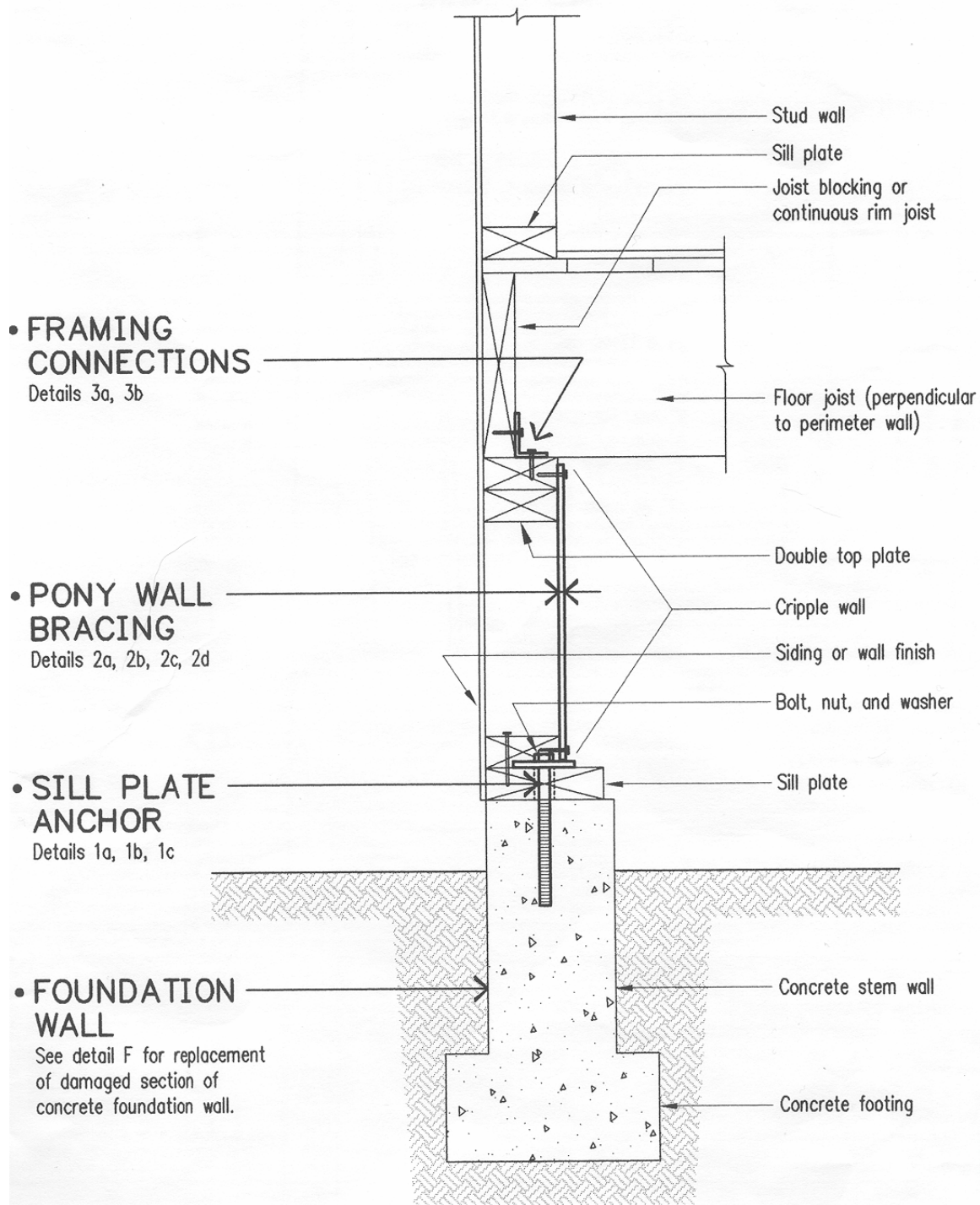
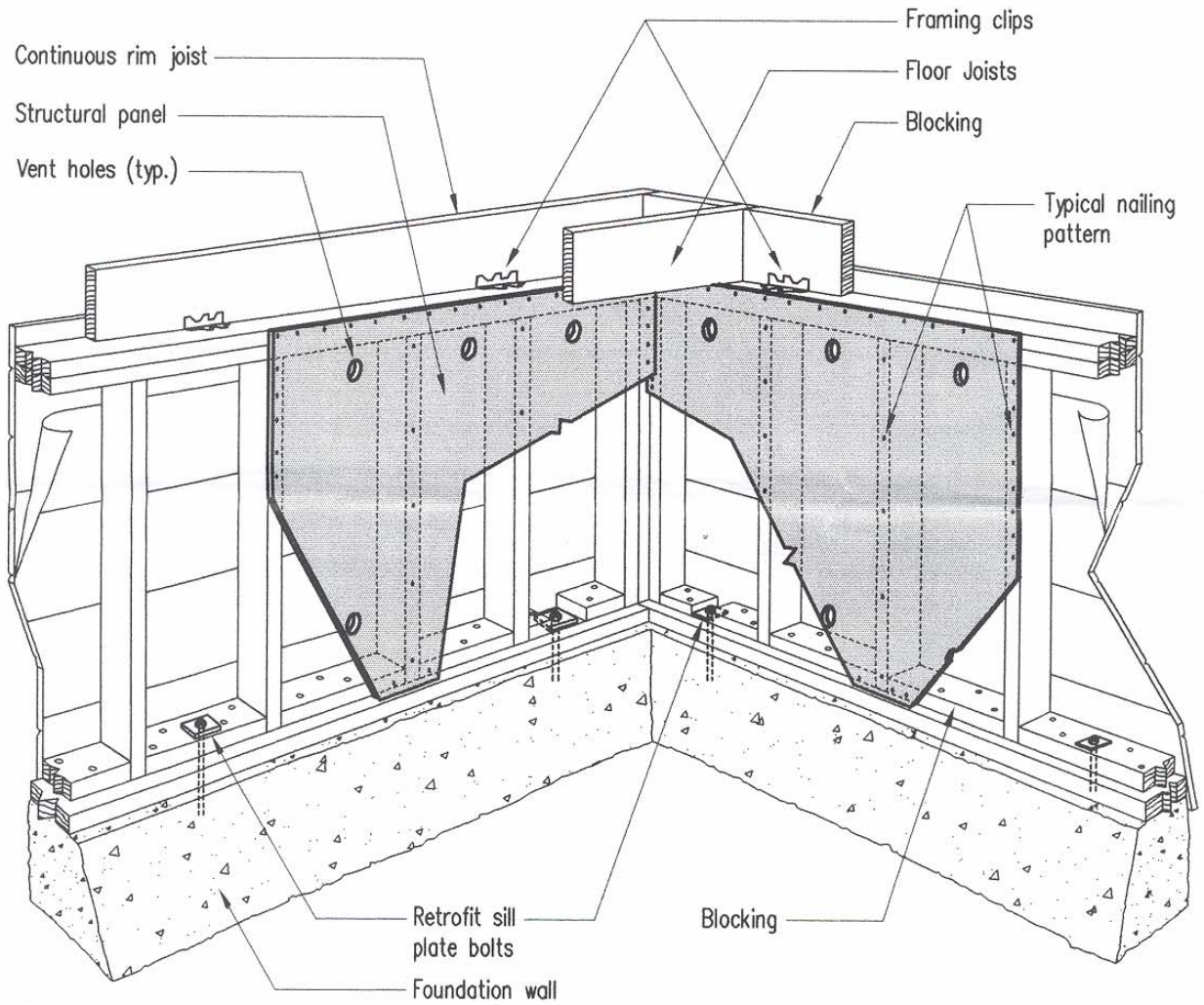

Figure 1 Side view of a typical retrofit wall section. Numbers refer to the drawings on the drawing details to meet various conditions.



Notes:

1. This sketch shows a sample wall section that has undergone a typical seismic strengthening retrofit.
2. This is a general sketch and is not intended to supersede requirements contained in the Standard Home Earthquake Retrofit Plan or in the specific installation details.

FRONT VIEW (isometric)

Figure 2 Isometric view of a typical retrofit, showing foundation anchor bolts, pony wall bracing, and framing clips, from inside the basement or crawlspace.

Detailed Task Descriptions

On the following pages are detailed instructions for completing the five tasks needed to complete your Earthquake Retrofit Plan Drawing.

Task 1. Drawing the foundation outline.

The SEHR Planset was provided to you at a Home Retrofit Class or from the building department in their permit application packet. In the space provided on the Planset (Section IIb), draw a detailed outline of the home's exterior foundation wall. Show the length of each exterior foundation wall segment, the height of all pony walls, the location of foundation wall obstructions and openings, and the direction of run (orientation) of floor joists and joist beams. In Tasks 2 through 5, you will identify and mark on your foundation outline the number of each standard plan detail you will use in your retrofit. You will also mark on the foundation outline where structural panels will be installed to brace pony walls. When all the drawing details and the structural panel layout are marked on the foundation outline, you will have completed your Earthquake Retrofit Plan Drawing. To see a completed sample, refer to Section IIa of the Planset. Figure 3 (below) shows another sample, this one a rough layout of a foundation wall.

Step 1. Measure the length of each segment of exterior foundation wall.

Use a tape measure of sufficient length. Some portions of the house, such as porch walls and additions, may not rest on the foundation. You must show these areas on your foundation outline for your plan to be complete. The initial drawing can be a rough sketch with the measurements rounded off to the nearest foot. Figure 3 is a sample rough sketch.

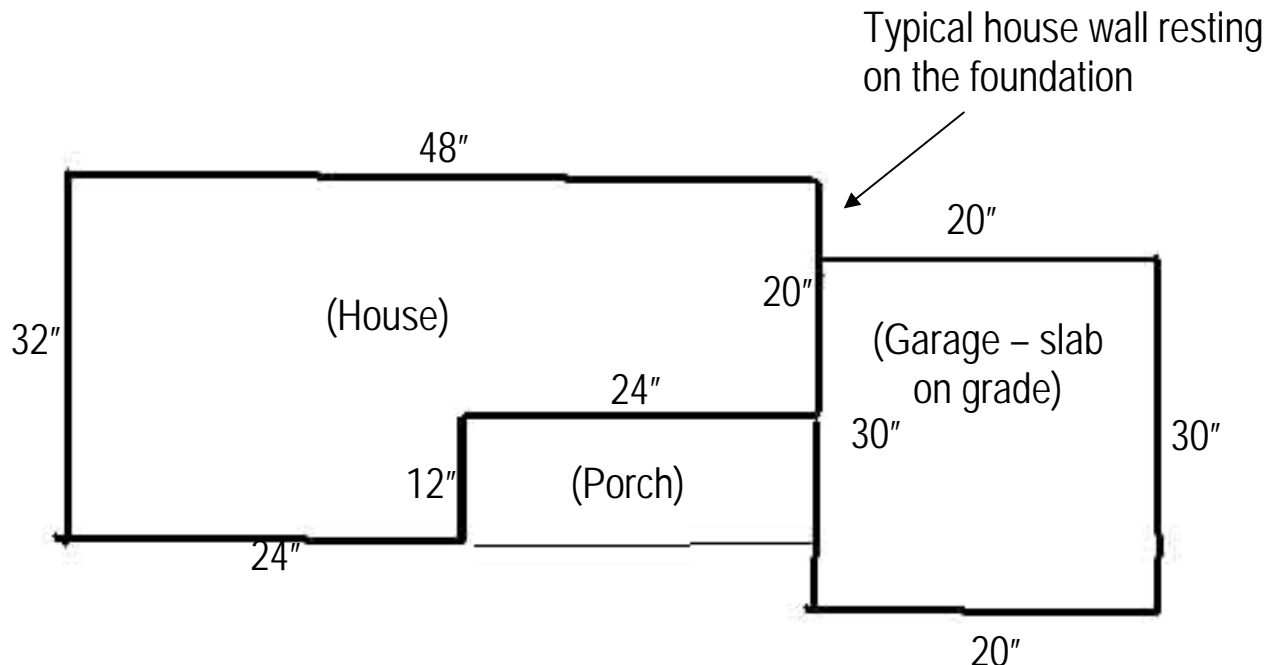

Figure 3 Sample rough sketch of foundation outline (view from above)

Step 2. Draw the foundation outline to scale.

Once the lengths of all the perimeter walls of the house have been measured and sketched as shown in Figure 3, prepare a precise drawing to scale using either graph paper or the grid lines in the space provided on the Earthquake Retrofit Plan Drawing (Section IIb). Check the box on the Drawing to indicate that the scale being used equals either one foot per square (4 feet per inch) or two feet per square (8 feet per inch).

Step 3. Mark the location of all foundation wall obstructions and openings on the foundation outline.

Certain elements along the perimeter of the house may interrupt the continuity of the foundation walls or pony walls. You should check the underfloor or basement area for openings in the foundation wall for fireplace and chimney footings; crawlspace openings; vent openings; gas and electrical meters, panels or piping; and any other breaks in the foundation wall caused by objects or openings that may project through sections of the foundation wall. Show on the scaled foundation outline the size and location of each perimeter wall obstruction or opening. Make sure to identify any area that is built on a concrete slab-on-grade or that does not have an underfloor space, such as an attached garage.

Step 4. Show the direction (the orientation) of all floor joists and beams.

The orientation of the floor joists and beams with respect to the pony wall or foundation wall determines the specific plan element needed to connect the floor framing system to the supporting structure.

End of Task 1

You have now completed a detailed drawing showing an outline of the home's foundation with obstructions and openings in the foundation wall and the direction of run (orientation) of all floor joists and beams noted.

Task 2 Select method of replacing sections of damaged concrete foundation wall, if necessary.

The second task in completing your Earthquake Home Retrofit Planset (SEHR) is to identify how you will replace a damaged section of a continuous concrete perimeter foundation wall that may have been determined to be damaged or in poor condition. To qualify to use the SEHR Planset, the foundation should be of concrete or reinforced masonry in good condition. Damaged or weak sections must be replaced before completing the earthquake retrofit work. Some weaknesses in the concrete foundation wall may not be identified until the retrofit work is being done.

A home that rests directly on the ground without an approved foundation or that has a foundation system made-up only of wood posts supported on isolated pad footings (post and pier construction) needs to have a new foundation system installed as approved by the building official. Discontinuous foundations and unreinforced masonry foundations need to be evaluated by a licensed design professional (such as an architect or engineer). When approved by the building official, these foundations may be strengthened according to the recommendations in the evaluation report rather than replaced.

Step 1. Select the concrete foundation replacement detail – Drawing Detail F.

Drawing Detail F on the SEHR Planset shows a simplified construction method that you may use to replace a section of damaged concrete foundation.

Step 2. Review the material information on the SEHR Planset: Section III - General Notes and read Section E.

All concrete shall be fully cured and hardened, uncracked and in sound condition. A screw driver may be used to probe the concrete to identify weakened sections. Some weaknesses in the foundation will become apparent when trying to install anchor bolts. A hole drilled into weakened concrete may become too large to hold the anchor bolt. Sometimes a chemical anchor installed using adhesives to hold the anchor bolt will provide a secure attachment. Concrete with excessive cracking, deterioration or damage shall be replaced. All new concrete replacement footings shall be of 2500 psi (pounds per square inch), or can also be 5½ sacks per cubic yard, minimum compressive strength.

Step 3. Review the installation information in Section F.

Proper shoring and sequence of replacement must be provided to avoid weakening the structure and creating a hazard for occupants or passers by. When existing footings and stem walls are replaced in sections, the person performing the work shall take care to insure that all reinforcing steel shall be lapped a minimum of 24 inches and shall be doweled into the existing concrete with adhesive or drypack a minimum of 8 inches. Note that the anchor bolt used in newly poured concrete has a J-shape to provide greater resistance to being pulled out during earthquake shaking.

End of Task 2

Task 3. Select method of anchoring the sill plate to the foundation wall

The third task is to identify how you will anchor the sill plate to the foundation. Anchoring the sill plate to the foundation prevents displacement of the framed walls relative to the underlying foundation wall. The standard plan detail you will use to anchor the sill plate to the foundation depends in part upon the amount of working space above the sill plate. Homes built before 1965 rarely have an anchored foundation that meets the plan requirements. Many homes built between 1965 and 1975 do have anchored foundations. However, a few homes built as recently as 1980 may be inadequately anchored. If existing bolt are found, they may need washers replaced with square plate washers (which perform better in an earthquake).

Section III - General Notes, Section G

Step 1. Select the applicable sill plate anchor detail(s) from the Plan Detail Reference Sheet – Plan Details 1a, 1b, 1c, and 1d.

A pony wall of at least 27 inches is needed to operate a common rotary hammer drill held in the upright position to install mechanical bolts or chemical anchors vertically into the sill plate (Fig. 4). Some special rotary hammer drills are designed to install vertical bolts into smaller spaces. Standard Plan Detail 1a on the Plan Detail Reference Sheet (Sheet 2), shows the installation of mechanical bolts or chemical anchors vertically through the sill plate.

When the pony wall is less than 27 inches you may be able to nail the top of an L-shaped side anchor plate into the sill plate using Plan Detail 1d on the Plan Detail Reference Sheet. The mechanical bolt or chemical anchor may then be installed into the side of the foundation wall through the holes in the side anchor plate.

If no pony wall is present above the sill plate, a flat side plate (Plan Detail 1c) or an adjustable side plate (Plan Detail 1d) may be used. The mechanical bolt or chemical anchor may be installed into the side of the foundation wall as in Plan Detail 1c. Unlike Plan Detail 1a and 1b there is not enough space to install mechanical bolts, chemical anchors, or nails vertically into the side plate used in Plan Detail 1c.

Several types of manufactured anchor side plates are designed for specific foundation and sill plate conditions. Figure 5 shows a sample manufacturer's sheet for an anchor side plate. The L-shaped plate, the flat plate, and the adjustable plate discussed above represent three common types. Using more than one type of plate may be necessary and is permitted. How far the sill plate is set back from the inside face of the foundation wall, as well as from any framing obstructions above the sill plate or the pony wall, will dictate what type of anchor plate can be used.

On your foundation outline, mark the number and location of each standard plan detail to be used to anchor the sill plate to the foundation.



Figure 4 Installing anchor bolts through the sill plate and into the foundation, using a rotohammer.
(Photo from Tom Hall)

UFP Universal Foundation Plate

The UFP10 Retrofit Foundation Plate cuts installation time in half. Designed to connect when the mudsill is offset from the foundation up to 2½" or extended beyond the foundation up to ½".

The UFP may be used in place of the FA, HFA and FAP connectors.

MATERIAL: 14 gauge.

FINISH: Galvanized. May be ordered HDG, check with our factory. See Corrosion Information, page 6-7.

INSTALLATION: • Use all specified fasteners; see General Notes.

- Loads are based on test results using Simpson's SDS½x3 screws, which are supplied with the UFP10.
- Alternate lag screws will not achieve published loads.

• Refer to T-ANCHORSPEC for post-installed anchorage solutions.

CODES: See page 12 for Code Listing Key Chart.

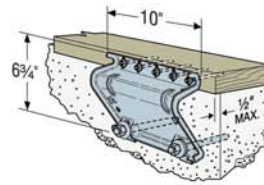

UFP10 installed on a Straight Foundation with ½" Offset Mudsill

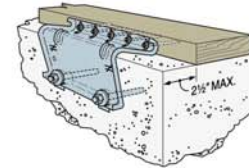

UFP10 installed on a Straight Foundation

U.S. Patent
5,732,519

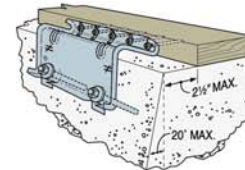

UFP10 installed on a Trapezoid Foundation

Model No.	Max Spacing to replace Anchor Bolt ½" or ¾" dia.	Fasteners		Allowable Load Parallel to Plate (133)	Code Ref.	
		Anchor Bolt Qty	Anchor Bolt Dia			
UFP10-SDS3	6'	2	½	5-SDS½x3	1340	30, 96

1. Allowable loads have been increased 33% for earthquake or wind loading, with no further increase allowed. Reduce where other load durations apply.
2. Each anchor bolt requires a standard cut washer.

FA/FAP/HFA/FSA Foundation Anchors

This series is for retrofit or new construction. These products may be used together as a system or in individual applications, designed and tested for earthquake and high wind conditions.

FA and HFA Foundation Anchors eliminate vertical drilling by nailing into the top of the mudsill. They facilitate installation when vertical space is limited, and resist forces between the foundation and mudsill. The FAP Plate connects the mudsill to the foundation. Designed to provide lateral load resistance.

FJA Foundation Joist Anchor nails or bolts directly into floor joist, and provides a direct connection between the foundation and joist. It provides uplift and lateral resistance. FSA Foundation Stud Anchor nails or bolts to floor joist, or nails to stud. Plywood shearwall may require notching with stud-to-foundation installation.

MATERIAL: FAP—7 gauge; all others—12 gauge

FINISH: Galvanized. May be ordered HDG, check with our factory. See Corrosion Information, page 6-7.

INSTALLATION:

- Use all specified fasteners; see General Notes.
- Select and install concrete anchor bolts in accordance with the manufacturer's recommendations.
- Use the RFB#4x6 with Epoxy-Tie for the anchorage system.

CODES: See page 12 for Code Listing Key Chart.

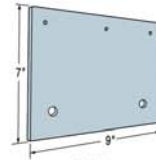

FAP (screws not included)

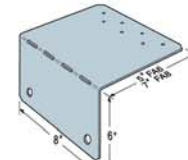

FA8 (FA6 similar)

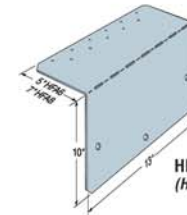

HFA6 (HFA8 similar)

Available with additional corrosion protection. Check with factory.

Model No.	Max Spacing to Replace Anchor Bolts		Fasteners		Allowable Loads DF/SP						Code Ref.	
	½"	¾"	Anchor Bolt Qty	Anchor Bolt Dia	(133)			(160)				
					Uplift	F ₁	F ₂	Uplift	F ₁	F ₂		
FAP	5½"	4"	2	½	3-SDS½ x 2½" + shim thickness	—	950	365	—	950	365	97
FA6	2½"	1½"	2	½	7-10dx1½"	—	400	515	—	400	515	8, 97, 121
FA8					7-10dx1½"	—	400	515	—	400	515	
HFA6	6"	6"	3	½	11-10dx1½"	—	1350	365	—	1400	365	9, 121
HFA8					11-10dx1½"	—	1350	365	—	1400	365	
FJA	—	—	2	½	8-10dx1½"	1000	185	60	1205	185	60	8, 36, 91, 121
					2-½MB	575	185	60	690	185	60	
FSA	—	—	2	½	8-10dx1½"	1000	—	—	1205	—	—	
					2-½MB	575	—	—	690	—	—	

1. Allowable loads have been increased 33% and 60% for earthquake or wind loading with no further increase allowed; reduce where other load durations govern.
2. For redwood mudsills, reduce F1 on HFA to 1215 lbs, and 840 lbs on FAP.
3. Spacing to be specified by the Designer.
4. FAP shall use a minimum SDS wood screw length of 2½" plus the shim thickness.
5. The shim must be fastened to the mudsill by means other than the FAP wood screw.
6. See page 20 for SDS wood screw information.
7. FAP may be installed with ½" HDG lag bolts. Follow code requirements for predrilling.
8. NAILS: 10dx1½" = 0.148" dia. x 1½" long.
See page 16-17 for other nail sizes and information.

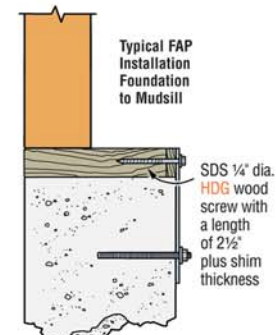

Typical FAP Installation Foundation to Mudsill

SDS ½" dia. HDG wood screw with a length of 2½" plus shim thickness

Add a shim between plate and sill when space is between ¼" and 1½". When space exceeds 1½" use the FA or HFA. The shim must be fastened to the mudsill by means other than the FAP SDS wood screw.

Figure 5 Sample manufacturer's sheet for anchor side plates. Carefully review material requirements in the SEHR Planset Section III - General Notes to verify that the hardware meets the allowable loads specified in the plan (F1 at least 850 for ½ inch bolt). Closer spacing is required for hardware with lower allowable load values in order to meet plan requirements. (NOTE: This drawing may show one-manufacture's product, but you can use equal or better approved products.)

Step 2. Read the material information in the SEHR Planset Section III - General Notes

Further explanations are that new anchors shall conform to ASTM (which will be stamped on the anchor) if existing anchors are not severely rusted or corroded. Install additional anchors as needed. All anchors shall have a minimum lateral load capacity of 635 lbs which is equivalent to a 1/2 inch bolt and a minimum load capacity of 980 lbs which is equivalent to a 5/8 inch bolt if installed in 2000 psi concrete at the minimum edge distance and depth of embedment per this planset's General Notes. All proprietary anchors shall have current International Code Conference (ICC) or equivalent approval. The size and spacing of all anchors used must meet the minimum prescriptive requirements in the SEHR Planset (Table 1).

There are two primary types of anchor bolts used to attach the sill plate to the underlying foundation wall: mechanical and chemical anchors. Note that square bearing plate washers are required for each.

Two main examples of mechanical anchors are the expansion bolt and screw anchor. Both anchors are placed in a pre-drilled hole of a specified size. The expansion bolt is hammered into the hole and the tightening of the bolt is what causes a connection between the anchor and sides of the hole. A screw anchor has self-undercutting, threaded teeth, which cut a channel into the walls of the hole as the anchor is screwed in place. Mechanical anchors develop shear and/or tension resistance to applied loads without grout, adhesive or drypack.

A chemical anchor is a threaded rod fastener that derives its holding strength from a chemical adhesive compound placed between the wall of the hole and the embedded portion of the anchor. Chemical anchor compounds are organic compounds comprised of resin and hardener, that form adhesives when blended together. Examples of adhesive compounds include epoxies, polyurethane, polyesters, methyl methacrylate and vinyl esters.

Chemical or mechanical anchors may be used interchangeably in concrete of average or better quality. Concrete of weaker quality may be indicated by spalling during drilling or setting of expansion bolts or failure of anchors to reach the minimum torque required. We recommend that you drill one hole and test expansion bolt before drilling all holes (making holes wider is difficult). Chemical anchors must be used in weaker quality concrete. This requirement does not waive the need to replace existing concrete foundations when damaged, deteriorated, or of unsuitable quality.



Figure 6 Mechanical anchor bolt for connecting the sill plate to the foundation wall. Note that square plate washers are required. In this photo, worker is cleaning out drilled holes using a brush and a vacuum. Also note the importance of protective safety equipment being used in these photos. (Photo from Tom Hall)

Step 3. Read the installation information in Section III - General Notes.

Mechanical bolts and chemical anchors must be embedded at least 4 inches vertically into the concrete foundation. Mechanical bolts and chemical anchors installed horizontally to attach a side plate to the foundation wall must not penetrate more than 2/3 the thickness of the stem wall or generally about 4 inches. Follow the manufacturer's installation requirements. The drilled hole must be of the correct diameter and cleaned of dust before insertion of anchor or bolt. Concrete dust in the hole may prevent the anchor bolt from being completely installed. Expansion bolts must be properly tightened to set the expanding portion of the assembly. The concrete must be able to engage the expanding portion without cracking.

Table 1 (Section III-General Notes) summarizes the minimum requirements for anchors and identifies the size and spacing for bolts and plates on the basis of the number of stories above the sill plate. Where obstructions (such as pipes or ducts) prevent the installation of bolts, the distance between bolts in the remainder of the sill must be reduced in order to provide the minimum number of bolts for the full length of the wall. However, do not install bolts closer than 12 inches on center.

Manufactured mechanical bolts, chemical anchors, and anchor side plates must be installed in accordance with the manufacturers' requirements. The size and spacing must meet the minimum prescriptive requirements listed on Table 1 (Section III – General Notes).

End of Task 3

Task 4. Select a method of strengthening the pony walls.

Pony walls are extremely vulnerable to earthquake damage unless they are properly strengthened. Most pony walls are constructed as wood-framed stud walls with some form of exterior sheathing and some lateral bracing. Homes built in Washington before 1975 generally do not have pony walls adequately strengthened to prevent earthquake-induced damage. However, some homes built as recently as 1985 may have inadequately strengthened pony walls. Without proper strengthening, pony walls may collapse due to excessive movement of the floor above the pony wall in response to earthquake shaking. This movement is called “side sway” (Fig. 7) and reflects the use of materials lacking sufficient strength and stiffness to resist the back and forth movement of the ground underneath the home. Figure 8 shows a pony wall that has not been strengthened with structural panels to prevent excessive side sway.

The SEHR Planset requires that pony walls be strengthened with structural panels to form a shear wall that will resist the excessive movement that can occur when earthquake shaking moves the home back and forth (Fig. 9). The foundation tends to move with the ground. The overlying building tends to lag behind the ground movement, displacing the home relative to the underlying foundation wall. Anchor bolts will help hold the home to the foundation. However, they will not prevent the collapse of the pony wall. Structural panels increase the pony wall's strength and stiffness to resist that collapse.

Pony walls on houses built before the early 1980s may have horizontal sheathing and/or siding installed directly on the pony wall studs (on the exterior side). Others may have "let-in" diagonal braces (typically 1 inch x 4 inch) in addition to the siding. Neither of these have sufficient strength and stiffness to resist earthquake-induced collapse of the pony wall. However, existing diagonal sheathing across the face of the pony wall studs will provide adequate strengthening if the boards are nailed to each stud they cross and to the top and bottom plates.

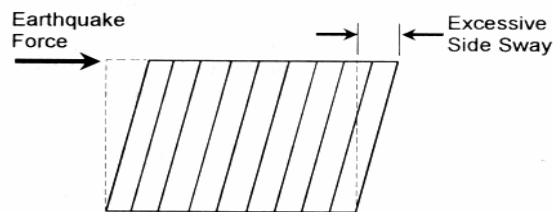

Figure 7 Illustration of the movement of a sample wall section in response to earthquake shaking. The displacement of the wall is called “side sway”.



Figure 8 Pony wall failure after the 1994 Northridge Earthquake from excessive side sway. (Photo from FEMA)



Figure 9 A pony wall without structural panels which are needed to strengthen it to resist excessive side sway.
(Photo by Tom Hall)



Figure 10 Installing structural panels on all perimeter walls helps prevent the walls from collapsing, keeping the house on its foundation. (photo from Tom Hall)

Step 1. Select the applicable pony wall strengthening detail(s) from the Planset – Drawing Details 2a, 2b, 2c, 2e, 2f.

Four plan details are provided showing how to install structural panels to strengthen the pony wall (Details 2a, 2b, 2c, 2e, 2f). Determine which wall sections require the installation of structural panels and assign the appropriate detail numbers "2a", "2b", "2c", "2e", or "2f" to those locations on your scaled foundation outline. These details are most appropriate for a home with a crawlspace or basement with unfinished walls. There will be an additional expense and effort required to install pony wall bracing in finished basement areas. The finishing will need to be removed and replaced.

Detail 2a shows the installation detail for a home in which the sill plate is the same width as the studs in the pony wall. This detail shows that the structural panels can be nailed directly to face of the sill plate and the face of the pony wall.

Detail 2b shows the installation detail for a home in which the sill plate is wider than the studs in the pony wall or the sill plate is embedded in the foundation. Blocking the full width between the studs in the pony wall is required to provide a surface to which the lower edge of the structure panels are nailed. This added blocking must be nailed to the existing sill plate below.

Detail 2c shows how to install structural panels on the exterior face of the pony wall studs. In this order the existing exterior siding and sheathing should be carefully removed and the wall repaired after installation of the panels. This approach may be practical where the interior face of the pony wall is not easily accessible, such as in a finished basement.

If a thicker structural panel is used to provide a flush wall surface, then care must be taken to use the appropriate sized nails to ensure the same wall strength will be achieved as for the prescribed panel thickness and nailing. If you are using $\frac{3}{4}$ " plywood then use galvanized 10d common nails (see Appendix) at 6" on center. If you need clarification, contact your local building department.

Detail 2e shows how to add blocking at the top of a pony wall to provide the regular nailing surface if the top plate is missing.

Detail 2f is a supplement for two and three-story houses, with pony walls, that do not meet Project Impact minimum requirements for the following:

- 2:1 aspect ratio in structural panels (length:height), and/or
- the percentage per pony wall to be braced with structural panels (Section III, Table 1).

Through the use of holdown hardware in panel sections less than 2:1, and an increase in the amount of fasteners required overall, Detail 2f offers a reduction to the percentage of pony wall that needs to be braced per wall. Refer to the Table for Detail 2f for more information.

Choosing Detail 2f effects all connections along a given pony wall. For instance, selecting this detail for a north wall condition means that all areas of structural upgrade along the north wall will follow these minimum prescriptive requirements.

Before selecting this detail, read it carefully and review the text and drawings provided in Detail 2f: Problem, Solution, Detail, and Table, as each of these contain necessary information. The requirements for Detail 2f apply only to the walls for which they are selected.



Figure 11 Refer to Drawing Detail 2d to determine how to cut-out a section of the structural panel to accommodate piping, etc. (Photo from Ben Emam)

Step 2. Read the material information on the SEHR Planset Section III - General Notes

The SEHR Planset requires that you use a nominal ½ inch or 15/32 inch wood structural panel rated as APA Rated Sheathing or APA Structural 1 Rated Sheathing or an equivalent rated by another trade association. The structural panel must be classed as Exposure 1 for durability and have a span rating of 32/16. Plywood and Oriented Strand Board (OSB) are both types of wood structural panels. Whichever one is used must meet these specifications.

When using plywood, a structural panel with a minimum of 4 plies is required. Plywood structural panels labeled CDX refer to grade-C and grade-D veneer with Exposure 1 durability. CDX plywood that meets the prescribed thickness, span rating, and number of plies may be used to strengthen the pony wall.

Structural panel products should be protected from moisture if stockpiled in a location exposed to moisture for a long period of time. Otherwise, loss of strength may occur.

Nails To achieve the appropriate shear strength, you must use 8d common nails with a minimum shank diameter of 0.131 inch to fasten your structural panels to the pony walls. Nails with a smaller shank diameter, such as 8d box nails, will not provide the minimum strength required in the prescriptive plan.

Step 3. Read the installation information on the SEHR Planset Section III - General Notes

You must install structural panels to strengthen pony walls on each pony wall section according to the Summary of Minimum Prescriptive Requirements on Table 1. To determine how much of the pony wall must be covered with structural panel, refer to the appropriate row on Table 1 (one-story, two-story, or three-story). Remember that a pony wall over 18 inches high must be treated as a story. A home with one-story and a 24 inch pony wall must be anchored and strengthened as a two-story home.

The amount and location of wood structural panels needed to strengthen the pony wall must meet the requirements specified on Table 1. When physical conditions, such as large window openings, prevent the installation of the required amount of wood structural panel, design assistance from a licensed design professional (such as an engineer or architect) may be needed.

Identify the following information needed to determine the structural panel layout; in Task 1 you completed the foundation outline. Now you will mark the following information to determine structural panel layout.

- (a) how much of the pony wall area that must be strengthened,
- (b) the minimum required length of each structural panel to be installed, and
- (c) where the structural panels must be placed to achieve the required panel spacing for each wall section.

On the scaled foundation outline, show the location and spacing of all the required structural panels that you will install in your retrofit. When structural conditions prevent the installation of the required number and size of structural panels according to the prescriptive plan, you will need to prepare an alternate structural layout plan with the assistance from a licensed design professional such as an engineer or architect.

Fasten structural panels with 8d common nails at 4 inches on-center at all edges and at 12 inches on-center at intermediate studs. An 1/8 inch gap should exist at vertical joints between structural panels to allow for product expansion. Two nails minimum should be driven into each stud. Nails should be driven so that the top of the nail is flush with the surface of the structural panel. Overdriven nails will reduce the shear strength of the panel by reducing the effective thickness and allowing the panel to buckle more easily when stressed. If nails are installed too close to the panel edge, that may allow the nail to pull through the panel during earthquake shaking. (Fig. 12) Install nails a minimum of 1/2 inch from the edge of existing studs, and where this dimension cannot be met, add a new stud adjacent to the existing stud. **Screws should not be substituted for nails.** Screws lack the flexibility of nails and may shatter rather than yield under shaking. For similar reasons of potential brittle failure, glue should not be substituted for nails, or used at all when fastening structural panels.



Figure 12 An example of overdriven nails. Nails should be driven flush to the surface of the structural panel, like the top one, and need to be a minimum ½” from the panel edge. (Photo from Tom Hall)

Per plan drawing, here’s an exercise to determine the amount of sheathing needed to strengthen the pony wall.

This exercise focuses on determining the amount and spacing of structural panels needed to strengthen the 39- foot-long pony wall segment shown on the right hand side of the Sample Plan Drawing (Section IIa of the Planset). The Sample Plan Drawing is for a home with one-story above the pony wall and a pony wall of varying height.

Step 1. Refer to the foundation outline to determine the height of the pony wall. The foundation outline in the Sample Plan shows this pony wall to be 24 inches high. Therefore, the pony wall must be counted as one-story for the purpose of determining how much structural panel is needed to strengthen the pony wall. Therefore, that side of the home should be strengthened using the minimum prescriptive requirements for two-stories.

Step 2. Summary of Minimum Prescriptive Requirements (Section III – General Notes, Table 1). Select Row 2 for requirements for a two-story home. Then, look under the column titled "pony wall strengthening requirements for individual wall sections" to identify the percentage of the wall that must be braced.

Table 1 (or Section III – General Notes, Section “i”) tells you that:

- At least 50% of the wall length shall be strengthened. (70% for a home with tile roof, stucco walls, or brick veneer.)
50% of the 39-foot-long wall shown on the Sample Plan is about 20 feet; therefore, at least 20 linear feet of structural paneling must be installed on this portion of the foundation wall.

- **Structural panel lengths shall be equal to twice the height of the pony wall but never less than 48 inches.** (Section III - General Notes, Section “i”, #1)
The pony wall height is 24 inches. Therefore the minimum length of each plywood panel must be twice that, or 48 inches (4 feet).
- Structural panels shall be installed at each end of the wall section.
A 48-inch-long panel is shown installed at each end of the 39-foot wall on the Sample Plan. So far, a total of 8 linear feet (96 inches) of structural panel has been placed on the pony wall. Thus, the location of the remaining 12 feet of the total strengthening requirement of 20 feet now must be marked on the foundation outline. Three 4 foot panels would meet the remaining requirements.
- Structural panels should be nearly equal in length and nearly equally spaced along each wall section. The exact layout will depend upon conditions along the wall.

Additional explanations for this exercise.

- The panels marked on the foundation outline are not all the same length as required in the minimum prescriptive standards. This is acceptable in order to accommodate actual field framing conditions and minimum percentage panel requirements. The panels should be *nearly* equal in length and *nearly* equally spaced along the wall.
- The 12-foot-long wall at the bottom left of the Sample Drawing on the SEHR Planset (Section IIa) is braced with two 4-foot -long panels. This far exceeds the 50% strengthening requirement for that wall. However, because the prescriptive standard requires installation of at least one panel of minimum length at the end of each wall section at the corners of buildings, the amount of structural panel shown placed along the pony wall is correct.
- The length of perimeter wall obstructions must be included when calculating the total length of structural panel required. For example, a wall that has 30 feet of pony wall and 10 feet of brick fireplace foundation is considered to be 40 feet in length. If it is supporting a one-story house, strengthening would be required along 20 feet of the pony wall.

End of Task 4

Task 5. **Select the method for connecting the floor framing system to the pony wall or foundation wall**

The floor framing system needs to be connected to the underlying pony wall. If there is no pony wall, the framing system needs to be connected to the sill plate. Lack of these connections may result in movement of the house off the pony wall or the foundation wall.

Step 1. Select framing connection detail from the SEHR Planset Details 3a, 3b, 3c, 3d, 3e and 2e

The Planset shows framing connections between the floor framing system and the underlying sill plate or pony wall. Drawing Detail 3a applies when the floor joist is perpendicular to the foundation wall. Drawing Detail 3b applies when the floor joist is parallel to the foundation wall.

A number of variations exist in conditions between the floor framing system and the underlying foundation wall or pony wall. Planset 3c, 3d, and 3e address common variations from characteristics of homes qualifying to use the prescriptive plan. The building official will need to determine if your use of one of these details provides an adequate solution for your home

- Plan Detail 2e – There are no pony wall top plates and the perimeter rim joist rests directly on top of the studs in the pony wall.
- Plan Detail 3c and 3d – There is no blocking between the floor joists of a cantilevered floor section at the point where the joists rest upon the pony wall or sill plate. This plan detail shows the installation of new joist blocking to provide a place to attach the framing clip.
- Plan Detail 3e – Parallel floor joists are too close to the sill plate or pony wall to allow access for the installation of framing clips.

Step 2. Read the material information on the SEHR Planset Section III - General Notes.

All framing clips shall be of minimum 18 gauge galvanized steel, a minimum 4-1/2 inch length and approved under ICC or equivalent for wood frame construction. The earthquake load capacity in the long direction must meet or exceed 385 lbs in dry lumber (Fig. 13).

Step 3. Review the installation information on the SEHR Planset Section III - General Notes.

The standard plan requires that you install metal framing clips at regular intervals along the perimeter of the underfloor framing system. The distance between clips depends upon the number of stories (Table 1). All metal connections and hardware must be installed as instructed by the manufacturer and in accordance with the requirements of these retrofit standards. The retrofit standard for spacing the framing clips ranges from a maximum of 32 inches on center for a one-story home to a maximum 16 inches on center for a three-story home (Table 1). In most one-story homes this means that one framing clip will be installed between every other floor joist bay. You will need a tape measure and marker to lay out this spacing when the floor joist is parallel to the foundation wall because there are no floor joists resting on the sill plate or pony wall to use as a guide.

The framing clips should be nailed to the top of the sill plate or pony wall and to the face of the continuous rim joist or joist blocking with 8d common, 1½ -inch-long joist hanger nails. Nails longer than 1½ inches should not be used to fasten the clips to the sill plate because they will over-penetrate the thickness of the 2x member, which could result in nails piercing exterior siding.

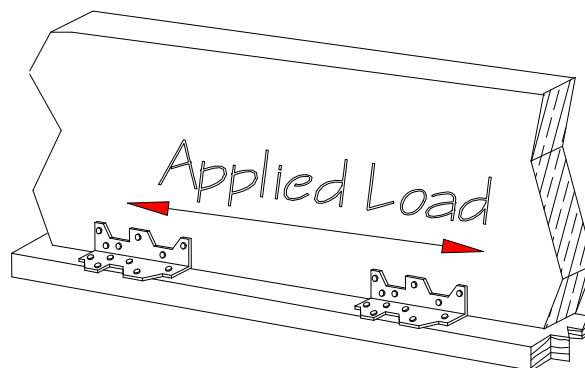

Figure 13 Illustration of a framing clip installed between the floor framing system and the underlying sill plate. The applied load generated by the force of the earthquake along the clip’s long direction is marked.

All round nail holes in the framing clips must be used in order to develop the load capacity required by the retrofit plan. Because of space limitations in this area of your home's floor framing system, you will need to use a special nailing tool such as a "palm nailer" to properly install this retrofit hardware.

Most houses have a continuous rim joist ranging in size from a nominal size of 2-inch-by-6-inch to a size of 2-inch by 10-inch located at the outside edge of the floor framing system. Other houses may have full depth 2x blocking between the floor joists. The framing clips may be nailed directly to a continuous rim joist or the 2x blocking. If there is no continuous rim joist or no full depth joist blocking, you must install 2x blocking between the joists to provide a place to attach the framing clips. The retrofit standard for installing joist blocking ranges from installation between alternate joists for a one-story home to installation between all joists for a three-story home (Section III – General Notes, Table 1).

REVIEW OF THE STEPS FOR COMPLETING AN EARTHQUAKE RETROFIT PLAN

Complete the Home Assessment Checklist to determine if your home qualifies to use the SEHR Planset and to identify the general type of retrofit work that must be done before developing a detailed earthquake retrofit plan for your home retrofit project.

You then use the rest of this guide to

- (1) Draw your Earthquake Retrofit Plan Drawing in the space provided on the SEHR Planset in the permit application packet and mark the scale used.
- (2) Select the Drawing Details reference numbers and the structural panel layout and mark them on your foundation outline.
- (3) Make a note about the materials you will use to implement each drawing detail.

Your completed earthquake retrofit plan drawing will address all of the following elements in the standard plan **that apply to your building's condition:**

- repairing or replacing damaged parts of the foundation
- anchoring the sill plate to the underlying foundation wall with anchor bolts or anchor side plates
- strengthening the pony walls with structural panels
- connecting the floor framing to the underlying sill plate or pony wall using framing clips

Make sure you have followed the "Sample Plan Drawing" shown on the SEHR Planset (Section IIa) as a guide for the preparation of your earthquake retrofit plan. The foundation outline you drew in Task 1 should be annotated with the appropriate information and plan details to address the conditions that exist in the home to be retrofit. Transfer your earthquake retrofit plan to the space provided on the SEHR Planset if you drew it on a separate sheet of paper.

You are ready to submit your completed earthquake retrofit plan to the building department for plan review and processing of your permit.

OBTAINING A BUILDING PERMIT AND FINISHING THE PROJECT

You must have a building permit before you retrofit your home. The permit process ensures that the proposed plan is reviewed and that installation has been performed in accordance with the voluntary minimum prescriptive requirements in the SEHR Planset. The inspection provides you quality control of work performed.

Once you have completed the SEHR Planset, take two copies of both the Planset, the Drawing Details, and the Home Assessment Checklist to the building department. Many copy stores have equipment to copy the larger sized sheets of paper. Department staff will review the Home Assessment Checklist and your Earthquake Retrofit Plan Drawing. They may ask questions about the project to make sure that no critical issues have been overlooked. When the building permit is issued, you will receive an approved copy of your earthquake retrofit planset.

Building Permit Issuance

If your Standard Earthquake Home Retrofit (SEHR) Planset and your attached drawing details are in order, the sheets will be stamped approved and a building permit issued upon payment of the required fees. Fees for an earthquake retrofit project permit are based on the value of the project. Fees vary from one jurisdiction to another, and many have lowered costs for retrofitting. A home that requires additional work to improve poor existing conditions, such as installing a new foundation, may require higher permit fees to cover the more expensive and complex project. An "Inspection Record Card" will be provided for use by the building inspector.

Beginning Work

With the permit in hand, you, the homeowner, may decide to complete the work or you may choose to hire a contractor. As every jurisdiction is different, check with your local building department on the length of time allowed to complete work under your permit.

Required Inspections

Have the project address and the permit number available and let the inspector know if it is for Project Impact-related bolting or pony wall bracing. Building department staff will visit your home to inspect the retrofit work. Generally one inspection will be completed after the anchor bolts are installed and one inspection after the pony wall bracing is installed. The contractor, or you as homeowner if you are doing the work yourself, is responsible to call your local building department or division inspector when you are ready for these inspections. Inspection will focus on work-related to the earthquake retrofit project.

Additional Inspections

If unusual structural conditions or site problems are uncovered after work begins, and these problems necessitate additional field inspections by the building department, supplemental fees may be assessed to cover the cost of the additional inspections. The building department will advise you beforehand if this need arises.

APPENDIX A: Definitions of Common Construction Terms

Anchor side plate--A metal plate or plates used to connect the sill plate or floor framing to the side of a concrete stem wall when conditions prevent anchor or bolt installation vertically through the sill plate.

Chemical anchor--A fastener placed in hardened concrete that derives its holding strength from a chemical adhesive compound placed between the wall of the hole and the embedded portion of the anchor. Chemical adhesive compounds are organic compounds, composed of resin and hardener, that form adhesives when blended together. Examples of chemical adhesive compounds include epoxies, polyurethanes, polyesters, methyl methacrylates and vinyl esters.

Pony wall--A wood-framed stud wall extending from the top of the foundation to the underside of the lowest floor framing. Also called a cripple wall or knee wall.

Embedment depth-- The depth of the anchor into the concrete.

Expansion bolt --A mechanical fastener placed in hardened concrete designed to expand in a self-drilled or pre-drilled hole of a specified size and engage the sides of the hole in one or more locations to develop shear and/or tension resistance to applied loads without grout, adhesive or drypack.

Installation torque--The amount of force applied to an anchor in order to create required load values.

Mechanical anchor—A fastener placed in hardened concrete that derives its holding strength by a mechanical interface between the anchor and the walls of the concrete hole without grout, adhesive, or drypack. Examples of mechanical anchors include expansion bolts and screw anchors.

Minimum concrete edge distance--The measure between the free edge of the concrete and the centerline of the bolt at which the concrete will not break away when the anchor is set or loaded in service. Minimum edge distances for anchors are given in the product approval

Holdown—Hardware used to resist overturning and tension forces. Used in pairs at the opposite ends of structural panel framing, holdowns connect stud framing to the concrete foundation. Holdowns require chemical anchoring and are not a replacement for the typical foundation anchor bolts. See product information for additional requirements and installation recommendations.

Oriented strand board (OSB)--A mat-formed structural panel product composed of thin rectangular wood strands or wafers arranged in oriented layers and bonded with waterproof adhesive.

Perimeter foundation--A foundation system that is located under the exterior walls of a building.

Plan detail--An individual drawing of a specific portion of construction containing dimensions, notes, and other information necessary to guide the work to be done.

Plywood--A structural panel product composed of sheets of wood veneer bonded together and with the grain of adjacent layers oriented at right angles to one another.

Screw anchor—A mechanical fastener with hardened self-undercutting, threaded teeth, designed to screw into a pre-drilled hole of a specified size in hardened concrete, achieving shear and/or tension resistance by a threaded interlock between its teeth and the concrete hole without grout, adhesive or drypack.

Snug tight--The condition when the full surface of the plate washer is in contact with the wood member and begins to slightly indent the wood surface.

Torque-set anchor--An expansion anchor whose wedge or sleeve engages the concrete base material in the drilled hole by the application of torque and where the amount of torque applied controls the degree of anchorage.

Wood structural panel--A structural panel product composed primarily of wood and meeting the requirements of United States Voluntary Product Standard PS 1 and United States Voluntary Product Standard PS 2.

APPENDIX B: Basic Concepts for Earthquake Resistant Design

Earthquake Shaking

When an earthquake occurs, the ground beneath a building shakes in all directions. How strong the shaking is at the building site and how much damage is produced depends on the following factors:

- **The “size” of the earthquake.** The size of an earthquake is usually described either by a number recording the ground motion, called magnitude, or by a description of the level of damage observed at a particular site, called the intensity.

The magnitude of an earthquake is similar to the number of watts used to indicate the strength of a light bulb. The initial magnitude reported by different earthquake monitoring centers may vary slightly due to the different locations of the recording devices used to calculate the magnitude. These minor differences are resolved when the recorded signals for a number of earthquake monitoring centers are combined. The earthquake’s magnitude will be reported as a single number (ie. 6.7) and is often used to calculate the amount of energy released by the earthquake.

The intensity of an earthquake is similar to the brightness of a light bulb observed at different locations relative to the bulb. The intensity of an earthquake is measured using a scale (written in Roman numerals) of increasing numbers representing increasing levels of observed damage to people and structures. Each earthquake may produce different intensities in different locations, based on the additional factors described below. The intensity assigned to a particular event will represent the greatest amount of damaged observed, called the maximum intensity.

- **The depth of the earthquake.** A shallow earthquake will typically cause the most severe damage near the epicenter, which is the point on the Earth’s surface directly above the earthquake’s point of origin. A deep earthquake of the same magnitude will cause less damage near the epicenter because the point of origin is now farther from the surface, but it will typically cause damage over a larger area.
- **The distance of the building from the fault causing the earthquake.** A fault is a weakness in the Earth’s brittle outer layer along which movement occurs. Sudden slip along a fault generates the shaking we call an earthquake. The distance to the place along the fault where slip occurred, called the hypocenter, is important in determining the resulting shaking. Buildings close to the fault will usually feel stronger shaking than those farther away.
- **The composition of the soil at the building site.** Hard, rocky or firm ground will tend to shake the most in response to rapid back and forth movements. A short, stiff building also shakes more strongly in response to rapid back and forth movements. Thus, a short stiff building like an Unreinforced Masonry building will typically sustain greater damage when shaken rapidly on a firm site. Soft sandy or clayey soil will tend to shake more in response to slower back and forth motions. A tall, flexible building shakes more strongly in response to slower ground motions. Thus, a tall, flexible building like a high rise will typically sustain greater damage when shaken more slowly on a soft site. This matching of ground motion to the natural period of vibration of the building producing stronger (amplified) motions is called resonance.

Building Forces

The size of the shaking generated in a building during an earthquake will depend upon the building's size and type of building materials as well as the ground accelerations produced by the earthquake's shaking. A large, heavy building will generate more force when set into motion by earthquake ground shaking than a small, light building. Force may be calculated by multiplying the building's weight times the ground acceleration caused by the earthquake's shaking.

During an earthquake the ground shakes back and forth. This causes forces to act on a building in all directions. The building's foundation tends to move with the ground. The overlying building tends to lag behind. This tendency of the building to lag behind the ground's motion is called inertia. Imagine a person in a speeding car. If the car stops suddenly, the person's inertia continues the forward movement of the body against the seat belt. If the car speeds up quickly, the person's inertial force resists the movement and the body is pressed into the seat as the car moves forward. An earthquake may repeat this sudden back and forth movement many times, weakening the building and possibly leading to collapse.

Building forces are greatest between the foundation and the first floor of the building. At this location the total weight of each overlying floor, walls and roof adds together, resulting in the highest level of force experienced by the building. This is also where the movement between the foundation and overlying building shifts back and forth relative to each other. For this reason, strengthening the connections between the foundation and the first floor of the building is the most important part of an earthquake home retrofit.

Horizontal Force Resisting System

Roof and floor systems are the horizontal elements of a house's earthquake force-resisting system. These horizontal elements are called diaphragms. The floor and roof systems transfer the horizontal, side-to-side earthquake forces to the vertical elements of a house (the walls) which, in turn, transfer the forces to the foundation and then the ground. This connected system allowing the transfer of forces through each building element to the ground is called the complete load path.

Weak walls do not do a good job of transferring the horizontal forces from the roof and floors to the foundation. Large picture windows, garage doors and other openings that weaken the ability of the wall to transfer the earthquake loads to the foundation may result in collapse of that floor. Also, inadequate materials and connections weaken the ability of the walls to transfer forces. These weaknesses can be especially damaging in the foundation area. Weak pony walls and inadequately bolted foundation sill plates are usually the most vulnerable to earthquake damage because they are located where the forces in the building are typically strongest due to the weight of the overlying structure and to the inertial movement between that structure and the foundation.

Horizontal Force Resisting System

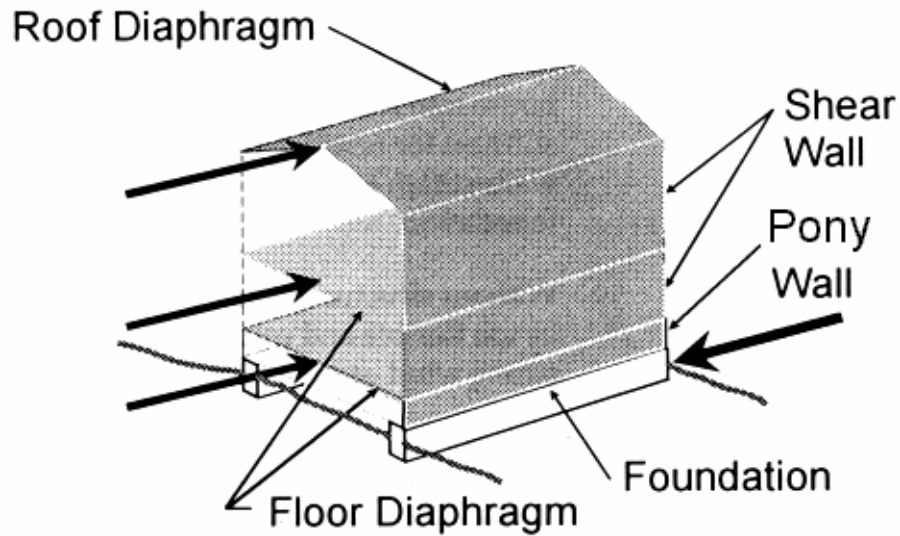





Need for Retrofit

Building code design requirements for earthquake resistance have improved dramatically in the last few decades, but there are many thousands of homes in communities throughout the Pacific Northwest that were constructed prior to the development of modern earthquake design requirements. These homes usually have weakness in their foundation to first floor connections that require strengthening in order for the structure to resist the potential forces of a major earthquake.

APPENDIX C: NAIL SIZES

FULL SCALE NAIL CHART

COMMON	Wire Diam.	Wire Gage	LENGTH	
16d	.162	8	3 1/2"	
★ 12d	.148	9	3 1/4"	
10d	.148	9	3"	
8d	.131	10.25	2 1/2"	

This chart can be used as a reference to check nail sizes.

Note: DO NOT USE 8d (.113) BOX NAILS.

★ 12d common and 16d sinker nails are interchangeable. They are identical wire diameter and length, but differ only in head shape.