



# DESIGN AND ANALYSIS OF WHEEL RIM

J.L.Miren Kisshan\* , K.Sankara Narayanan,  
Ben Mathew Augustine, Dr. D.Vijayanapathy  
Department of Mechanical Engineering  
Saveetha School of Engineering,  
Saveetha Institute of Medical and Technical Sciences,  
Chennai

June 4, 2018

## **Abstract**

Wheels are one of the important components in the vehicle. The two wheeler, there are two types of wheels used. One is alloy wheel and another one is spokes wheel. Mostly alloy materials are used for fabricate the wheel rim. The main reason used for the alloy material is increase the efficiency of the two wheeler by reducing the weight. This project is to create the motor bike wheel rim model by using SOLIDWORKS software and the created model is analyzed by the ANSYS workbench software. The structures and system are evaluated by the ANSYS tool. In the ANSYS workbench analysis is simple for the complex structures. Visualization, pre-processing and analysis are the three process involved in the ANSYS. In this project aluminium magnesium alloy and steel alloy are chosen for the motor bike wheel rim. The Fatigue analysis is chosen for find the life and safety of the wheel rim. For the both materials the maximum force is applied.

**Keywords:**wheel rim, solidworks, ansys, analysis and Fatigue tool.

## 1 INTRODUCTION

In every modern vehicle it has part which is fully integral from the bearing. It is known as wheel development. In vehicle running condition, wheels are encountered by the dynamic loads and static loads by the help of the suspension system. In the vehicles, wheels are used for move the vehicle while it supporting a mass. A two wheeler wheel rim is shown in the figure 1. It is rotates in their own axis by the circular shape.



Figure 1: Alloy wheel rim

The rolling of the axle friction which overcomes from the facilitating motion is known as wheel. The external force or gravity needs for moment of the wheel its own axis. The flywheel, steering wheel and ships wheel are also works at the same mechanism. The important thing for wheel is economy and safety. Because humans are used the vehicle economically and safely. For designing and optimization of wheel have four technical problems. They are performance, manufacturability, weight and style of the wheel rim. Aluminium alloy, magnesium alloy and steel are used to fabricate the wheel rim. Some vehicle wheel rims are also made by the titanium material. The wheel rim design is based on the loading conditions which are applied over the rim.

## 2 MATERIALS AND METHODOLOGY

The designed motor cycle wheel rim was import to the ANSYS workbench. In the ANSYS workbench software the material was selected. In this paper, aluminium magnesium alloy and steel alloy D6AC was selected in the ANSYS workbench software.

### 2.1 Methodology

The motor bike wheel rim was created in the SOLIDWORKS software. The created bike wheel rim was analysed in the ANSYS workbench 15.0 software. In the ANSYS workbench, the motor bike wheel rim was analysis for it is life by the fatigue analysis with two different materials. The results of the both materials are compared with each other.

## 3 MODELLING

The motor cycle wheel rim model was created by the SOLIDWORKS 16 software. The wheel rim dimensions are taken from the present motor bike (Honda shine) wheel rim. This method is known as reverse engineering method. The created motor bike wheel rim was shown in the figure no 2.

## 4 ANALYSIS

The ANSYS software is carried out the motor bike wheel rim analysis using FEA method. The motor bike wheel rim 3D model was created by the SOLIDWORKS software. The created 3d model was saving in the Step format. The maximum numbers of engineering problems are solved by the numerical analysis technique of the FEM. In this paper ANSYS workbench 15.0 is used for fatigue analysis the motor bike wheel rim with various boundary conditions. The import design from solidworks is shown in the figure no 3.

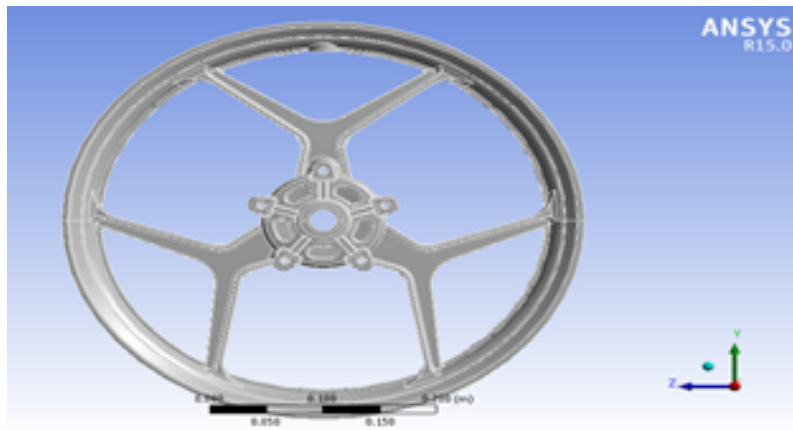

Figure 2: 3D model of the wheel rim

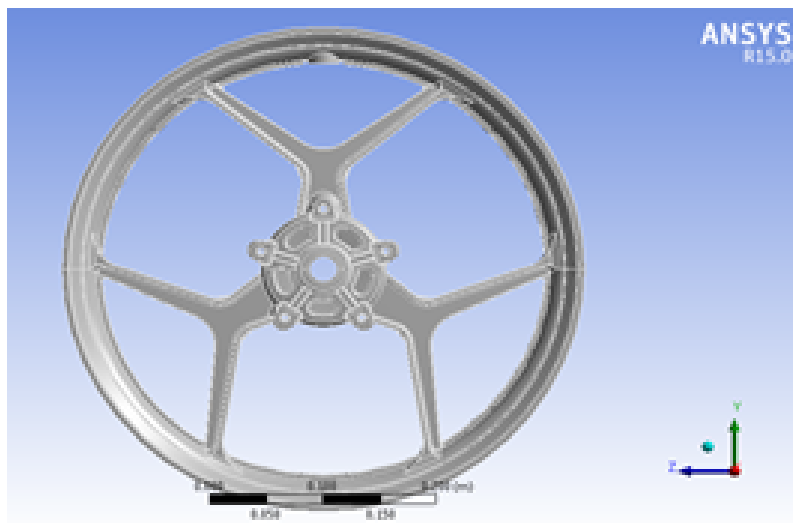

Figure 3: Wheel rim import to ANSYS

## 4.1 Meshing

For the drastic changes of the model is based on the meshing. It is suitable or common one for all parts in the computer simulation. The nodes are created in the meshing. In the analysis, different methods and tools are used for meshing the model. The fine meshing of the wheel rim is shown in the figure no 4.

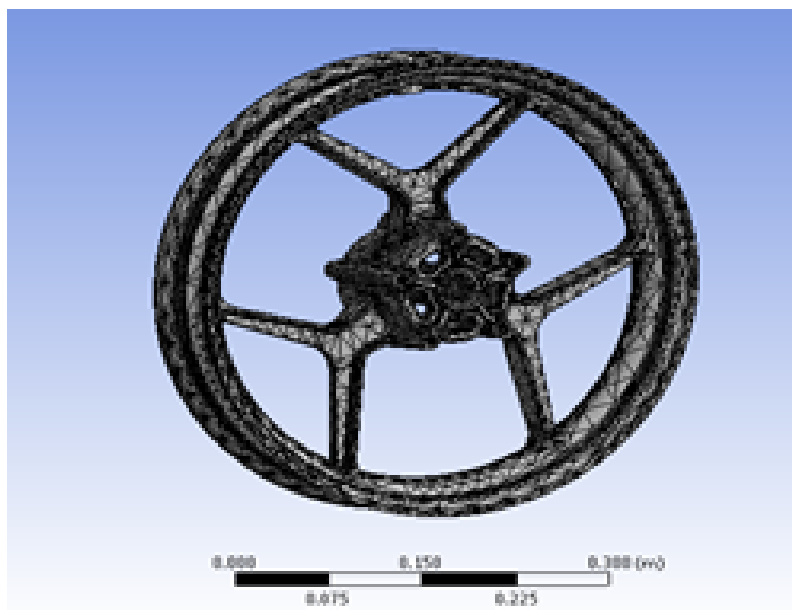

Figure 4: Wheel rim mesh

## 5 RESULT AND DISCUSSION

### 5.1 Total deformation

The total deformation of the aluminium magnesium alloy and steel alloy are shown in the above figure no 5. The both materials are analysed in the same boundary conditions. The pressure and load are applied in the wheel rim.

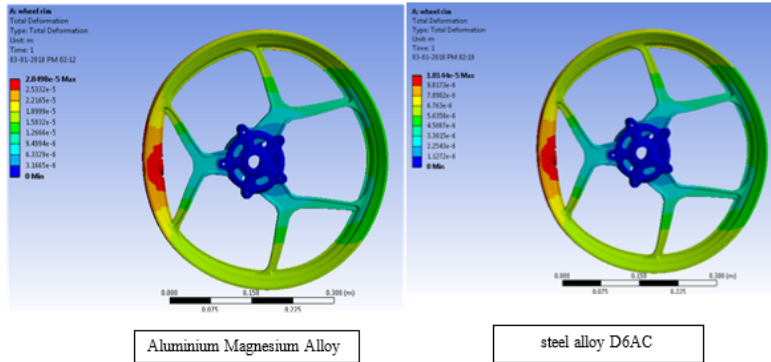

Figure 5: Total deformation

### 5.2 Safety factor

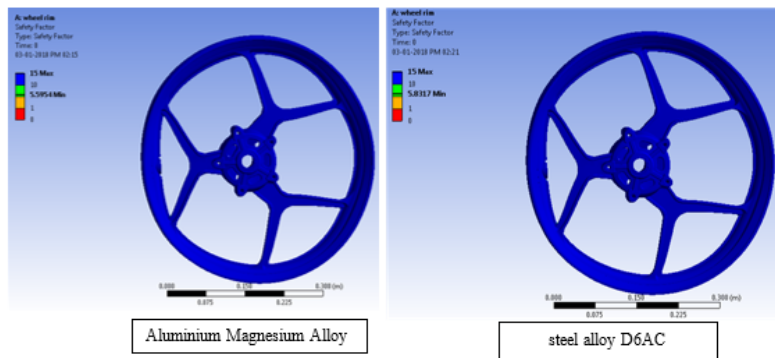

Figure 6: Safety factor

Safety factor is important one for every component. The figure no 6 shows the safety factor for the aluminium magnesium alloy and steel alloy. Both material has maximum 15 safety factor. But the average factor safter of steel alloy is more than the aluminium magnesium alloy.

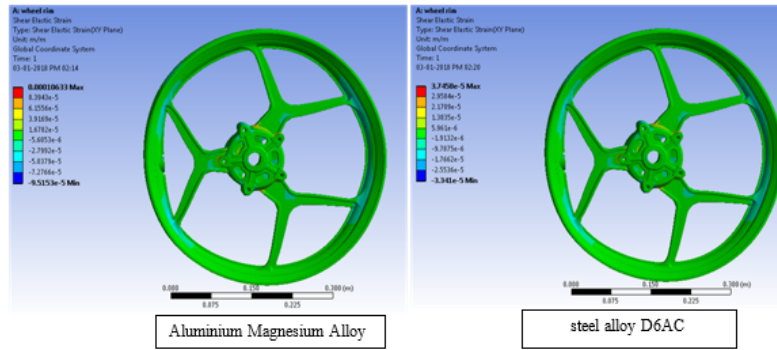

Figure 7: Shear elastic strain

5.3 Shear Strain

The elastic strain of the motor bike is important result because the change in dimension is also safety factor. The figure no 7 shows the shear elastic strain of the aluminium magnesium alloy and steel alloy.

5.4 Shear Stress

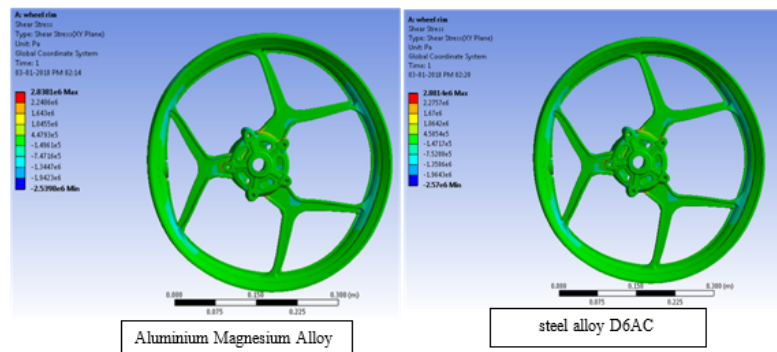

Figure 8: Shear elastic stress

The component strength is based on the stress capability. The shear stress of the aluminium magnesium alloy and steel alloy are

shown in the figure no 8. The both materials are analysed by the same boundary conditions.

### 5.5 Life

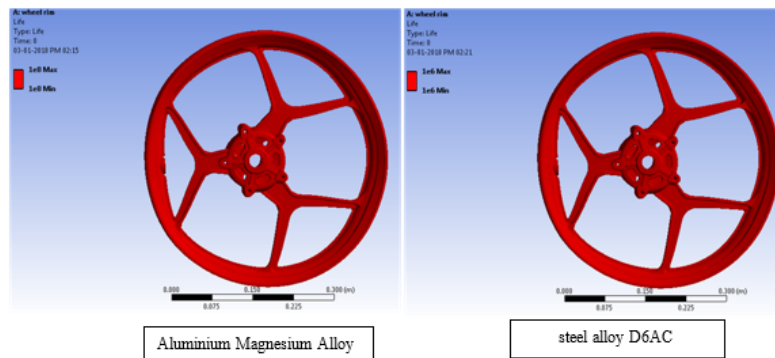

Figure 9: Life of the wheel rim

Life of the wheel rim analysed done by the fatigue analysis method. The component or wheel rim life is calculated in the figure no 9. By the above result the aluminium magnesium alloy has more life time than the steel alloy D6AC.

Table 1: Result and Discussion

Results	Aluminium Magnesium Alloy	steel alloy D6AC
Life	$1 e^8$	$1 e^6$
Shear stress	$2.8381 e^6 \text{ pa}$	$2.14888 e^6 \text{ pa}$
Shear strain	0.00010633	$3.7458 e^{-5}$
FOS min	5.595	5.831
Total deformation	$2.8490 e^{-5} \text{ m}$	$1.0144 e^{-5} \text{ m}$

The motor bike wheel rim was analysed by the ANSYS workbench software. The results of the both aluminium magnesium alloy and steel ally are showed in the above figures. The results values are noted in the table no for comparing each other. The results are getting by the same boundary conditions. In the above table the motor bike wheel rim life, safety factor, shear strain, shear stress and deformation are noted with the units.



## 6 CONCLUSION

The motor bike wheel rim was successfully created by the SOLIDWORKS software. The created model was analysed by the ANSYS workbench software. The fatigue analysis is done in this paper. The both aluminium magnesium alloy and steel alloy are analysed in the same boundary conditions. By the result by the above result the aluminium magnesium alloy has more life time than the steel alloy D6AC. The aluminium magnesium withstand in more stress. But the steel alloy has less deformation than the aluminium magnesium alloy. By the comparison the aluminium magnesium alloy is more suitable for the wheel rim.

## References

- [1] Karthi, V., Ramanan, N., & Hillary, J. J. M. (2014). Design and analysis of alloy wheel rim. *International Journal of Innovative Research in Science, Engineering and Technology*, 3(2), 71-77.
- [2] Daniel Antony C , Prince Jerome Christopher J.(2016). Design and Analysis of Two Wheeler Alloy Wheel Rim Using Composite Materials. *International Journal of Innovative Research in Science, Engineering and Technology*, (5)5.
- [3] Tejas Mulay, Harish Sonawane, Prof. P. Baskar. Design And Analysis Of Two Wheeler Front Wheel Under Critical Load Conditions. *International Journal of Application or Innovation in Engineering & Management (IJAIEEM)*, 3(5), 2319 4847.
- [4] P. Meghashyam, S. Girivardhan Naidu and N. Sayed Baba. Design and Analysis of Wheel Rim using CATIA & ANSYS. *International Journal of Application or Innovation in Engineering & Management (IJAIEEM)*, 2(8), 2319 4847.
- [5] K. Srinivasa Rao, M .Rajesh, G.Sreedhara Babu .Design And Analysis Of Alloy Wheels. *International Research Journal of Engineering and Technology (IRJET)*, 4(6), 2395-0072.
- [6] G.Radhakrishnana, V.R.Palaniappana, M.Manivannanb, S.Mayakannanc M.Magudeswarand, S.A.Srinivasand.Design

and Analysis of Wheel Rim with Spiral Flexures. South Asian Journal of Engineering and Technology Vol.2, No.23 (2016) 162-170.

- [7] Turaka.venkateswara Rao , 2,Kandula. Deepthi , 3,K.N.D.Malleswara Rao. Design & Optimization of a Rim Using Finite Element Analysis. International Journal of Computational Engineering Research (IJCER), 04(10), 2250-3005.
- [8] V.Dharani kumar, S.Mahalingam, A.Santhosh kumar. Review on Fatigue Analysis of Aluminum Alloy Wheel under Radial Load for Passenger Car. IJEDR, Volume 3(1), 2321-9939.
- [9] S. Chaitanya, B.V.Ramana Murty .Mass Optimization of Automobile Wheel Rim. International Journal of Engineering Trends and Technology (IJETT) Volume 26 Number 3- August 2015.



