

Honeywell

COMPONENT MAINTENANCE MANUAL

Part No. 066-50007

DESCRIPTION AND OPERATION

1. Description (TASK 34-42-37-870-801-A01)

A. **General** (Subtask 34-42-37-870-001-A01)

- (1) This section contains descriptive information covering the ALA-52B Radio Altimeter (ALA-52B). The ALA-52B is shown in Figure 1 (GRAPHIC 34-42-37-99B-802-A01).

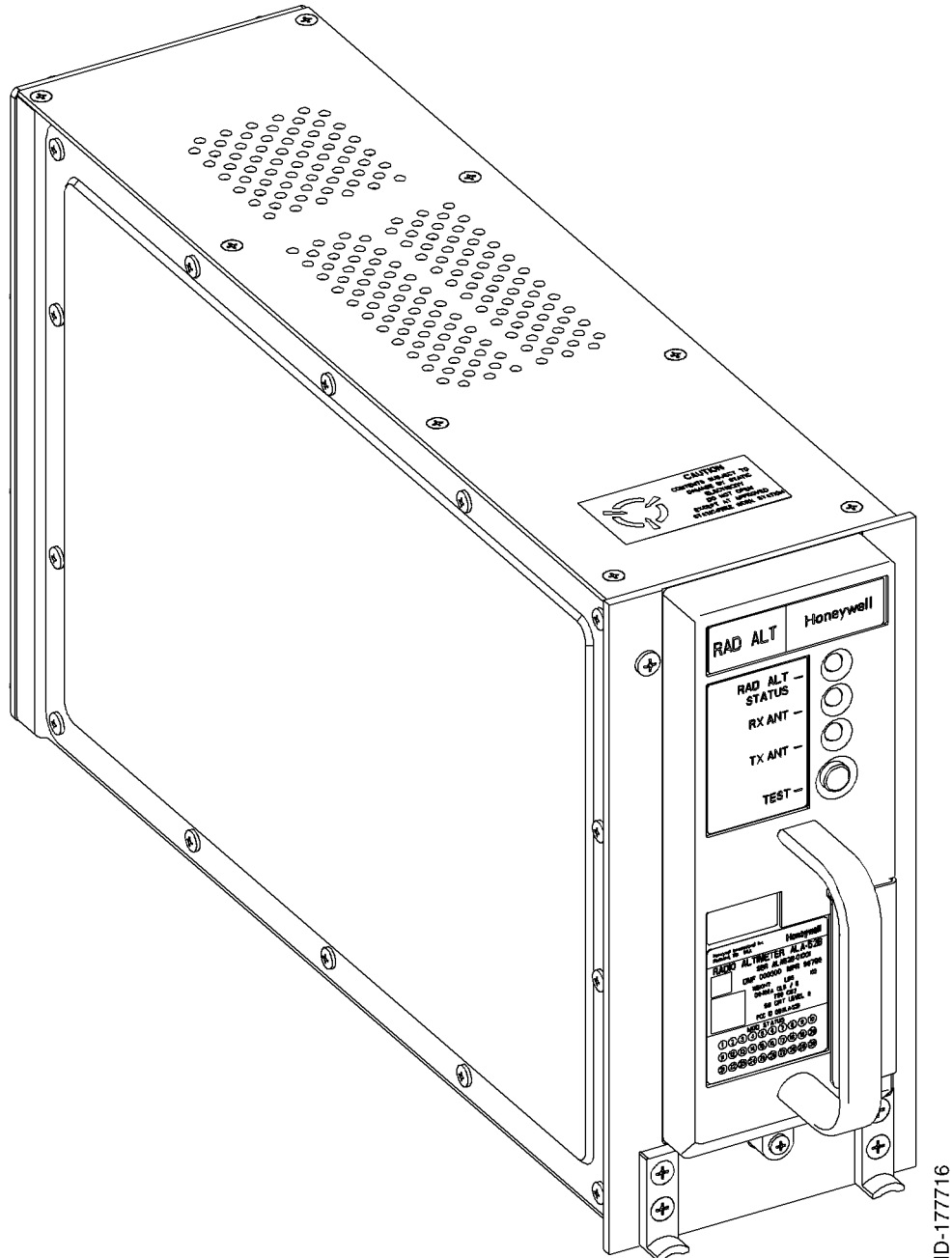

Figure 1. (Sheet 1 of 1) ALA-52B Radio Altimeter (GRAPHIC 34-42-37-99B-802-A01)

EFFECTIVITY _____
ALL

34-42-37

Page 1
10 Oct 2007

Honeywell

COMPONENT MAINTENANCE MANUAL

Part No. 066-50007

- (2) The ALA-52B is part of the Honeywell ALA-52B Radio Altimeter System. The ALA-52B is a lightweight, solid-state, digital airborne altimeter designed to provide accurate, digital height measurements above terrain during aircraft approach, landing, and climb-out phases. It is a low-range altimeter that incorporates two different and independent microprocessors, one of which performs the primary altitude computation while the second independently verifies the computation by comparison.

2. Configuration (TASK 34-42-37-870-802-A01)

A. Overview (Subtask 34-42-37-870-002-A01)

- (1) Table 1 lists the features contained in the ALA-52B. Table 2 contains a brief description of each feature.

Table 1. ALA-52B Configurations

Honeywell Part Number 066-50007	Features			Maximum Weight (Lbs/Kg)
	Basic Unit	Fault Memory	CMC Compatible	
-1111	X	X	X	8.6/3,9

Table 2. ALA-52B Features

Feature	Description
Basic Unit	Airborne solid-state radio altimeter that incorporates two different and independent microprocessors, one of which performs the primary altitude computation while the second independently verifies the computation by comparison. The altitude information is supplied to the AFCS and height displays on the instrument panel. The front panel contains LEDs that indicate the operating status of the unit. The front panel also provides a user interface for test and troubleshooting, including a test button and an RS-232C 25-pin "D" connector. The RS-232 front panel connector is used for testing the ALA-52B through a front panel adapter.
Fault Memory	A nonvolatile, single-chip fault memory that allows the recording of faults associated with a particular flightleg. Sixty-four flight legs are available with each flight leg made up of a flightleg information header containing a fault record section for recording ten airborne faults and three ground faults. When all flight legs are used, the oldest flight leg is reused.
CMC Interface	The ALA-52B interfaces fault memory and BITE data between radio altimeter and line maintenance CMC for the purpose of extracting maintenance information and initiating tests. Designed to conform with ARINC 429 interfaces, and ARINC 604.

EFFECTIVITY _____
ALL

34-42-37

Page 2
10 Oct 2007

Honeywell

COMPONENT MAINTENANCE MANUAL

Part No. 066-50007

3. Leading Particulars (TASK 34-42-37-870-803-A01)

A. Unit Specifications (Subtask 34-42-37-870-003-A01)

(1) Table 3 lists the leading particulars for the ALA-52B.

Table 3. ALA-52B Leading Particulars

Characteristics	Description
Form Factor	ARINC 600 3 MCU
Dimensions	14.04 in. (35,66 cm) long by 3.56 in. (9,04 cm) wide by 7.64 in. (19,41 cm) high
Weight	8.6 lb (3,9 Kg) maximum
Power Requirements	30W, +28 V dc
Temperature:	
• Operating	5 to +158 °F (-15 to +70 °C)
• Storage	-67 to +185 °F (-55 to +85 °C)
Cooling	ARINC 600 forced air
Humidity	Zero to 95% relative humidity at 122 °F(50 °C)
Altitude	50,000 ft (15,240 m) above mean sea level
Warm-up period	Stable operation within 6 seconds
Frequency Range	4.235 to 4.365 GHz
Transmit Power	+26 dBm (nominal at antenna port)
Operating Range of Altitudes	-20 to 5000 ft (-6,1 to 1524 m)
Accuracy	±1.5 ft (0,46 m) or 2%, whichever is greater
Data Outputs	ARINC 429 range and CMC interface
Aircraft Installation Delays	40, 57, 80 ft
Pitch Limits	±20°
Roll Limits	±40°
Doppler Error	Compensated using dual slope FM ramp
Self-Test	Automatic in-flight, manual from discrete, ARINC 429, or front panel
Integrity Monitoring	Continuous self-monitoring establishes operational status at all altitudes
Fault Reporting	Conforms to Boeing 777 formats

B. Environmental Certification (Subtask 34-42-37-870-004-A01)

(1) The ALA-52B meets the environmental conditions of the RTCA document number DO-160E, Environmental Conditions and Test Procedures for Airline Electronic/Electrical Equipment and Instruments. Refer to Table 4.

EFFECTIVITY _____
ALL

34-42-37

Page 3
10 Oct 2007

Honeywell

COMPONENT MAINTENANCE MANUAL

Part No. 066-50007

Table 4. Environmental Certification Categories of ALA-52B

Test	Category
Temperature and Altitude	A2/B2
In-Flight Loss of Cooling	Z
Temperature Variation	B
Humidity	A
Operational Shocks and Crash Safety	B
Vibration	S
Vibration Curves	B
Explosion Atmosphere	X
Waterproofness	X
Fluids Susceptibility	X
Sand and Dust	X
Fungus Resistance	X
Salt Spray	X
Magnetic Effect	A
Power Input	A
Voltage Spike	A
Audio Frequency Conducted Susceptibility - Power Inputs	R
Induced Signal Susceptibility	ZC
Radio Frequency Susceptibility (Radiated and Conducted)	WE
Emission of Radio Frequency Energy	M
Lightning Induced Transient Susceptibility	ZZZZZ
Lightning Direct Effects	X
Icing	X
Electrostatic Discharge	A
Fire, Flammability	C
NOTE: Category X = Test not applicable.	

EFFECTIVITY _____
ALL

34-42-37

Page 4
10 Oct 2007

Honeywell

COMPONENT MAINTENANCE MANUAL

Part No. 066-50007

4. Brief Description of Equipment (TASK 34-42-37-870-804-A01)

A. **Mechanical Description** (Subtask 34-42-37-870-005-A01)

- (1) The ALA-52B is contained in a standard ARINC Characteristic 600, 3-MCU case with side panels. Electrical connection to the aircraft wiring is made through an ARINC 600, series number one, multiple-section connector centered vertically.
- (2) Table 5 lists all modules and assemblies in the unit. Figure 2 (GRAPHIC 34-42-37-99B-803-A01) shows the location of the modules and assemblies.

Table 5. Module and Assembly Designations

Module/Board	Honeywell Part Number	Reference Series	Connectors
Final Assembly	700-1796-001	---	W4, W6, W8, W11, W20, W21
• Rear Interconnect CCA	722-4667-002	1200	J1001, J1212, J1214, W2, W23
Main Processor CCA	722-4703-002	2000	J2001, J2002, J2003, J2005 thru J2012
Power Supply Module	710-0366-001	---	---
• Input CCA	722-4767-001	3100	P3102, W6, J3108
• Output CCA	722-4577-005	3300	J3302, P3310, P3313
Front Panel	700-1784-001		
• LED CCA	722-4692-002	4000	J4001, J4002, J4003, W5, W9
Monitor Processor Module	300-90234-0502	6000	J6018, J6043, J6044, J6045
RF Assembly	727-0026-001	9000	W4, W6, W7, W20, W21
• RF Module CCA	722-4656-005	9000	J9039, P9033

EFFECTIVITY _____
ALL

34-42-37

Page 5
10 Oct 2007

Honeywell

COMPONENT MAINTENANCE MANUAL

Part No. 066-50007

Blank Page

EFFECTIVITY

ALL

34-42-37

Page 6
10 Oct 2007

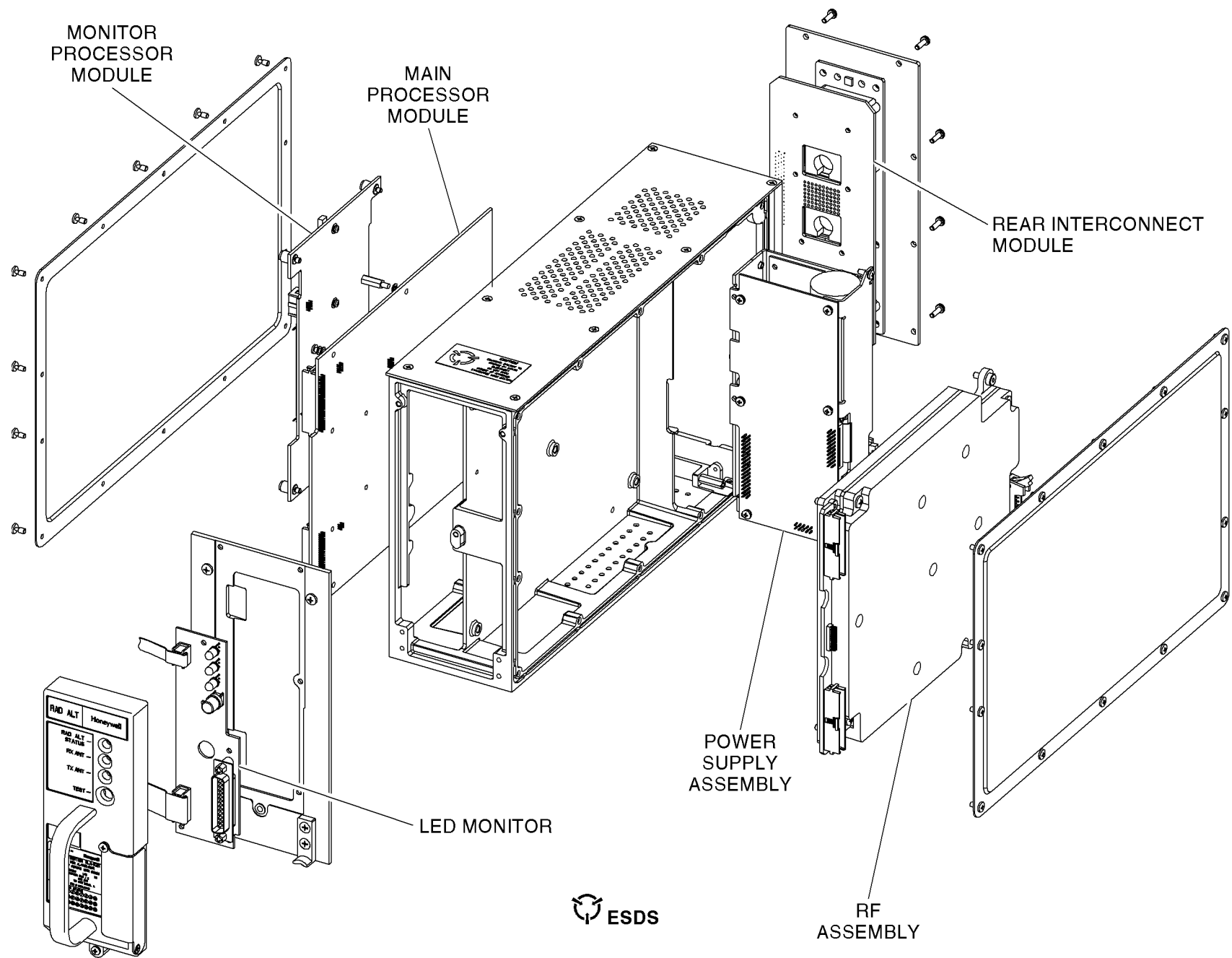

Figure 2. (Sheet 1 of 1) Module and Assembly Location (GRAPHIC 34-42-37-99B-803-A01)

ID-177717

Honeywell

COMPONENT MAINTENANCE MANUAL

Part No. 066-50007

B. Electrical Description (Subtask 34-42-37-870-006-A01)

- (1) Figure 3 (GRAPHIC 34-42-37-99B-804-A01) shows the ALA-52B interconnections in the aircraft. Antenna cabling is determined by the setting of the AID strap pins in the middle plug. The round trip delay from the ALA-52B transmitter port to the receiver port is set to the AID value for the return signal that corresponds to a reading of zero feet.
- (2) The middle plug also contains the ARINC 429 altitude bus outputs that connect to the AFCS, cockpit altitude indicators. Data recording equipment in the form of a flash card is available for in-flight test, though normally it is not required. For most installations, ARINC 429 bus number 1 is connected to the Flight Management Control Computer, and ARINC 429 bus number 2 is connected to the altitude indicators on the instrument panel. ARINC 429 I/O is also provided for interface with the CMC.

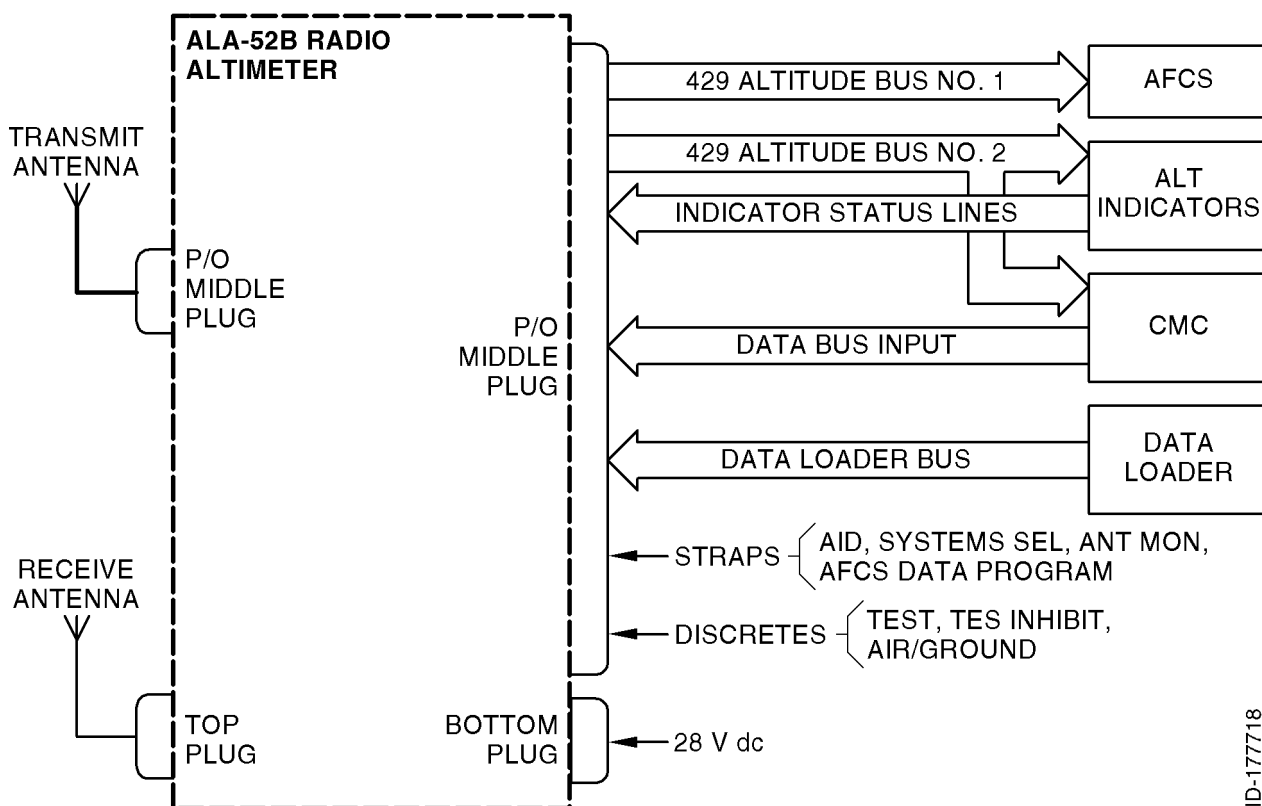

ID-177718

Figure 3. (Sheet 1 of 1) ALA-52B Block Diagram (GRAPHIC 34-42-37-99B-804-A01)

- (3) Besides the AID strap pins, system select strap pins are provided to designate the installed equipment as unit number 1, 2, or 3. The antenna monitor strap pin enables antenna monitoring, and the AFCS data program strap pins set the mode of operation of the ARINC 429 altitude buses in case an ALA-52B failure is detected.
- (4) Discrettes from other systems provide test activation, the inhibiting of test, and air/ground indication.
- (5) An RS-232 port on the ALA-52B front panel (not shown) provides an attachment for a hand-held tester for additional ramp test information, and shop test interface.

EFFECTIVITY _____
ALL

34-42-37

Page 9
10 Oct 2007

Honeywell

COMPONENT MAINTENANCE MANUAL

Part No. 066-50007

5. Theory of Operation (TASK 34-42-37-870-805-A01)

A. Overall Operation (Subtask 34-42-37-870-007-A01)

- (1) The basic objective of the ALA-52B is to provide accurate height above the ground terrain with a high degree of integrity during the approach, landing, and climb out phases of aircraft operation. This is accomplished by transmitting a frequency modulated continuous signal to the ground.
- (2) The frequency modulation is a linear dual slope ramp. During the time required for the transmitted signal to bounce off the ground and return to the aircraft, the transmitted signal has changed frequency. When the transmitted signal is mixed with the return signal bounced up from the ground, a baseband signal is produced at a frequency that represents the difference between the transmitted and returned signal frequencies. Since this difference frequency is proportional to the delay between the transmitted and received signals, it is also proportional to the altitude of the aircraft.
- (3) The difference frequency signal is amplified sufficiently and applied to two independent DSPs. The amplifier gain increases with frequency to compensate for attenuation due to increased range. The DSPs perform FFT and extract the lowest peak frequency. This process is repeated periodically. The results are averaged and verified in the microprocessors before being supplied to the 429 altitude data buses.
- (4) The verified digital altitude information is then routed to the peripheral equipment where it is further processed for pilot display, ground proximity warning, and AFCS usage.

B. Block Diagram (Subtask 34-42-37-870-008-A01)

- (1) RF Module
 - (a) The RF module, controlled by the main processor, transmits and receives the altimeter signal. BITE circuitry is included to both test and continuously monitor the RF module functions.
 - (b) The process of generating a transmission is driven by a VCO based PLL that is controlled by a DDS. The transmitter chain supplies the receiver LO as well as the required input for the calibration circuitry. The transmitted signal is radiated from the transmit antenna located on the underside of the aircraft.
 - (c) The transmitted signal, after bouncing off the ground below the aircraft, is collected by the receive antenna.
 - (d) A pair of RF switches are provided to channel the calibrated 300-foot delay element signal through the receiver during self-test. The self-test operation performs a full transmitter and receiver check. The self-test operation is activated manually by the pilot or automatically when the ALA-52B is acquiring a signal.
 - (e) The received signal is mixed with the part of transmitted signal, producing a difference frequency signal that is amplified and fed to an A/D converter on the main processor module.

EFFECTIVITY _____

ALL

34-42-37

Page 10
10 Oct 2007

Honeywell

COMPONENT MAINTENANCE MANUAL

Part No. 066-50007

(2) Main Processor Module

- (a) The main processor module controls the radio altimeter operation, performs signal processing of the difference frequency and test signals, and controls the aircraft interfaces and the data displayed on the front panel.
- (b) The main processor provides all the control signals to generate an up-down linear ramped frequency-modulated carrier wave output, determines the mode of operation, and provides all RF control signals. It also processes the difference frequency signals digitally. The return signal and test signals are converted to digital data streams using an A/D converter. In addition, the main processor module performs BITE, I/O, flash card interface, and monitor processor module interface functions.
- (c) The main processor module is divided into three major sections: the DSP section, the 486 CPU microprocessor section, and the I/O section.
- (d) When replacing the main processor module, refer to the Alignment Procedure, in the TESTING AND FAULT ISOLATION (PGBLK 34-42-37-1000) section and the SW Data Recording and Loading in the REPAIR (PGBLK 34-42-37-6000) section of this manual.

1 DSP Section

- a The DSP section is used to process the analog outputs from the RF module and to generate some of the control signals to the RF module for transmit modulation, automatic gain control, and test signals. The difference frequency signal from the RF module is digitized using a 12-bit A/D converter. The A/D converter is also used to monitor signals from the BITE test points on the RF module and the power supply voltages. The digitized data from the A/D converter is stored in a FIFO memory device which is accessed by the DSP. The DSP processes the difference frequency and calibration frequency into altitude information. Data is exchanged with the CPU section through a dual-port RAM, providing maximum throughput of both processors.

2 CPU Section

- a The CPU section does frame-to-frame processing of the altitude data from the DSP section providing the resulting altitude to the I/O section. The microprocessor in the CPU section controls all major functions of the radio altimeter. Programmable logic devices serve as the microprocessor controller and provide the interfaces to the memory devices (boot routine, program, fault, and data), the data recorder/data loader flash card, and the front panel display driver.

3 I/O Section

- a The I/O section provides the two ARINC 429 altitude outputs as well as ARINC 429 interfaces with other aircraft systems including the CMC. All discrete inputs external to the radio altimeter are processed by the I/O section. The I/O section also generates the external discrete outputs, which are buffered to prevent damage to the processor circuitry. The

EFFECTIVITY _____

ALL

34-42-37

Page 11
10 Oct 2007

Honeywell

COMPONENT MAINTENANCE MANUAL

Part No. 066-50007

I/O section also contains an RS-232C production test interface. This test interface is also used to update serial number, part number and configuration memory as applicable, utilizing a stand-alone PTM tool or integrated PTM tool in the Quantum Line Tester, when the main processor module is replaced.

- (3) Monitor Processor Module
 - (a) The monitor processor module provides a second signal processing path using a DSP. The DSP processes the received signal and calibration signal supplied in digital form from the Main Processor A/D converter. Also present are a clock, an ARINC 429 receiver/selector, and static memory.
 - (b) The primary function of the monitor processor module is to provide the ALA-52B with the integrity that permits Category III operations by acting as an independent monitor for the main processor altitude computations.
- (4) Power Supply Module
 - (a) The power supply module is a self-contained, high-efficiency, switching power supply that converts the 28 V dc aircraft power into the required +5 V dc, +12 V dc, and -12 V dc, operating voltages. A power-down interrupt signal provides advanced notice of a power loss allowing the processors to temporarily retain their status.
- (5) Rear Interconnect Module
 - (a) The Rear Interconnect module provides interface between the ARINC connector, the main processor, and the power supply modules. Lightning protection for I/O signals is provided on the Rear Interconnect.
- (6) Display Data Module
 - (a) The display data module is mounted behind the front panel and provides an interface to an operator through LEDs, which are visible from the front of the ALA-52B. In addition to the LEDs, the module has a pushbutton switch and a connector.
 - (b) The connector is used for testing the ALA-52B through a compatible test set or test panel.
- (7) Memory Card Interface Connector
 - (a) The ALA-52B ALA transceiver is provided with a connector for a PCMCIA flash card for programming the unit at the factory or service shop.

6. Detailed Theory of Operation (TASK 34-42-37-870-806-A01)

A. General (Subtask 34-42-37-870-009-A01)

- (1) See the appropriate schematic for the ALA-52B Radio Altimeter subassemblies described in this section. All electrical signals are shown in uppercase characters. If the signal does not contain such a suffix, then the signal is generally a dual-state signal such as a clock or data bus.
- (2) There are six subassemblies of the ALA-52B Radio Altimeter described in this section. They are:

EFFECTIVITY _____

ALL

34-42-37

Page 12
10 Oct 2007

Honeywell

COMPONENT MAINTENANCE MANUAL

Part No. 066-50007

- RF module
- Main processor module
- Monitor processor module
- Power supply assembly
- Rear interconnect module
- Front panel module.

B. RF Module (Subtask 34-42-37-870-010-A01)

(1) General

- (a) The RF module transmits and receives FM modulated C-Band signals that are used to determine the altitude above the ground. When the transmitted signal is mixed with the return signal bounced up from the ground, a baseband signal is produced at a frequency that represents the difference between the transmitted and return signal frequencies. The baseband signal frequency is directly proportional to the altitude above the ground. This analog baseband signal is the primary output from the RF Module. A simplified block diagram of the RF circuitry is shown in Figure 4 (GRAPHIC 34-42-37-99B-805-A01)
- 1 The transmitted signal, centered at 4.3 gigahertz with a maximum possible span of +/-100 megahertz is radiated from the transmit antenna located on the underside of the aircraft, and is subsequently (after bouncing off the ground) collected by the receive antenna. A directional coupler picks off some of the transmit signal which is mixed with the received signal, producing a difference signal that is amplified, filtered and fed to an analog-to-digital converter on the Main Processor module.
 - 2 BITE circuitry is also included to both test and continuously monitor the RF module functions. A portion of the transmit signal is also fed into a bulk acoustic wave device that provides a reflected signal calibrated to a time delay equivalent to 300 feet (0.616usec). Cal mixer extracts a signal corresponding to the difference frequency between transmit and delay element signals. The difference frequency signal is fed through a multiplexer to the A/D converter on the Main Processor board for calibration and self-test purposes
 - 3 The PLD receives control signals from the DSP of the Processor Module and directs them to appropriate circuitry on the RF module. A major function of this PLD is to control the DDS which provides a nearly ideal linear frequency sweep as a reference signal to the PLL within the transmitter chain.

EFFECTIVITY _____

ALL

34-42-37

Page 13
10 Oct 2007

Honeywell

COMPONENT MAINTENANCE MANUAL

Part No. 066-50007

Blank Page

EFFECTIVITY

ALL

34-42-37

Page 14
10 Oct 2007

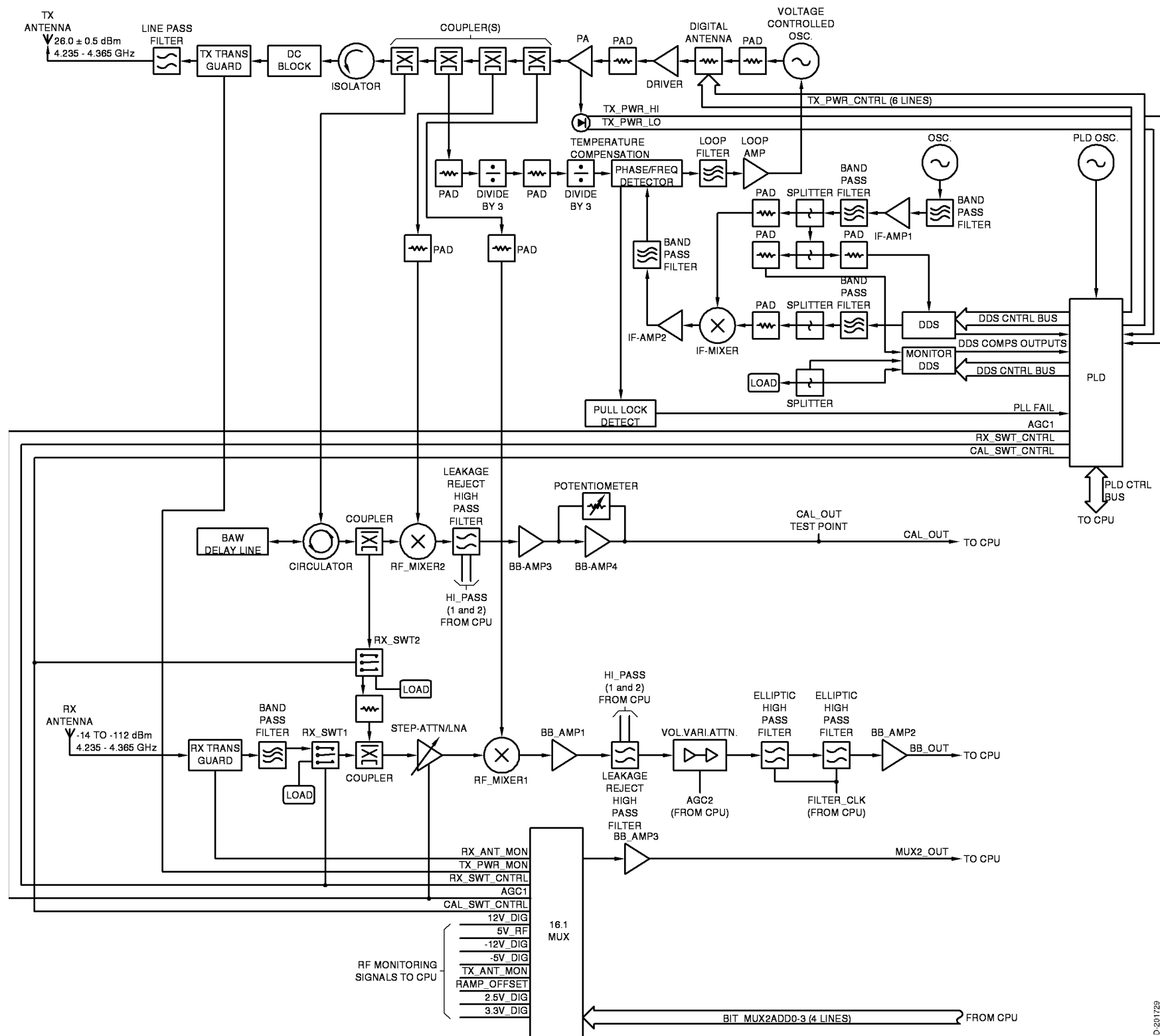

Figure 4. (Sheet 1 of 1) RF Module Block Diagram (GRAPHIC 34-42-37-99B-805-A01)

ID-201729

EFFECTIVITY
ALL

Honeywell

COMPONENT MAINTENANCE MANUAL

Part No. 066-50007

(2) Transmitter Chain

- (a) The transmitter chain is driven by a VCO based PLL that is controlled by a DDS. The transmitter chain supplies the receiver LO as well as the required input for the calibration circuitry. The DDS is programmed by the PLD which is controlled by the Processor Module. A second DDS, called the monitor DDS is driven with the same frequency set-up as the main DDS in order to provide a comparison reference to the main DDS. The lock-detect signals from the compared DDSs and the PLL are used by the PLD to monitor the failure modes of the DDSs and the transmitter chain.

1 Reference Oscillator

- a The transistor based oscillator is powered by a 128 megahertz single tone crystal, Y1 and amplified by a X3 multiplier, Q5 to 384 megahertz. The 384 megahertz signal is filtered by a comb-line filter and amplified by a gain block, U14 and filtered again before providing the clock signal to the DDSs (U18, U32) and an LO signal to the IF mixer (U24). Two 3 decibel splitters are employed to split the signal into three outputs, two with equal amplitude and phase at 0 dBm and one with 3 dBm. The 0 dBm signals are used to reference the DDSs(DDS1-REF, DDS2-REF). 3 dBm signal is used as IF_LO signal.

2 DDS

- a Both of the DDSs (U18, U32) are driven by the PLD (U512) to generate a frequency sweep between 82.66 megahertz to 104.88 megahertz (approximate maximum sweep) with the external reference clock 384 megahertz. The main DDS (U32) output is feeding the IF mixer as well as the PLD where it is compared with that from the monitor DDS.
- b The linear frequency ramp generator U32 includes an on-chip comparator. The comparator signals are square waves. The bandwidth is greater than 200 megahertz and has a common-mode input range of 1.3 volts to 1.8 volts. This signal helps eliminate phase noise and jitter.
- c The linear frequency ramp generator U32 output frequency range is 82.66 megahertz to 104.88 megahertz. The DDS frequency sweep output (DDS_OUT) on U32-20 and -21 is routed through, transformer T3, a 120 megahertz low pass filter and a 3 decibel coupler to mixer U24. The signal from the ramp generator is mixed with the 384 megahertz IF signal so that the linear frequency modulation is translated up in frequency to 466.66 megahertz to 488.88 megahertz. These frequencies correspond to 4.200 gigahertz and 4.400 gigahertz divided by 9 in the PLL circuit.

3 IF Mixer:

- a The DDS_OUT signal and the IF_LO signal are routed to IF mixer U24. The output on U24-4 has a frequency range of 466.6 megahertz – 488.8 megahertz(upper sideband). The output of U24 is routed through an amplifier U27 and a 477 megahertz bandpass filter to PFD U33-3.

EFFECTIVITY _____

ALL

34-42-37

Page 17
10 Oct 2007

Honeywell

COMPONENT MAINTENANCE MANUAL

Part No. 066-50007

4 PLL

- a The PLL consists of PFD (U33), loop filter (U28), VCO (G1), digital attenuator(U20), preamp (U19), power amplifier (U12) and two successive divide by 3 frequency dividers (U21, U25) for a total frequency division by 9. The power amplifiers and the digital attenuator are included in the PLL in order to improve the phase linearity of the overall transmitter. The loop bandwidth is approximately 1 megahertz which is required by the fast sweep and the desired ramp linearity. An external PLL lock detect circuitry which is driven from the PFD U33 provides the status of the PLL to the PLD.
- b The phase-frequency detector PFD U33 is used in low noise phase locked loop. It detects the phase/frequency difference between the 477 megahertz signal provided by the upconverted DDS signal and the frequency divided signal derived from the 4.3 gigahertz VCO to generate output pulses that are proportional to the phase and frequency difference between the two signals. The reference signal is the RF output of U24 from the 477 megahertz bandpass filter (466.6 to 488.9 megahertz) applied to U33-3. The second signal is the PLL_FDBK_VCO and the compliment PLL_FDBK_NVCO from frequency divider U25. The phase-frequency detector U33 uses the phase difference between the two signals to supply frequency up and down pulses to comparator U28. The output of U28, a dc voltage, is used to tune the VCO G1.

5 VCO

- a The VCO G1 has a range of 4.2 to 4.4 gigahertz. The power output is a typical 5.0dBm typical from a single supply of +3 .3 V DC. The control voltage from U28 on G1-22 (VTUNE) increases the output frequency of the VCO as the voltage increases. The control voltage range is 3.5 to 7.0 V dc.

6 Digital Attenuator

- a The RF output of VCO G1 is routed to digital attenuator U20-2. Digital attenuator U20 has a range of 2.4 to 8.0 gigahertz, with an insertion loss of less than 3.8 decibel and attenuation accuracy is ± 0.5 decibel. The attenuator can be set between 0 to 31.5 decibels with 0.5 decibel steps. Six control voltage inputs, switch between 0 and +3 to +5 V dc, are used to select each attenuation state. The digital attenuator U20 is controlled by the PLD U512 for dynamic power control that is required for board to board variation and temperature variation.

7 Driver Amp, Power Amp and Power Detector

- a The RF output of Digital Attenuator U20-2 is connected to driver amplifier U19-3. The driver amplifier U20 provides about 20 decibels of gain and the PA U12 27 decibels of gain. Both operate with 5 volt supply and consume about 130 mA and 600 mA respectively. The PA provides an internal power detector which uses an external temperature

Honeywell

COMPONENT MAINTENANCE MANUAL

Part No. 066-50007

compensation circuitry. The temperature compensated circuit drives two comparators whose output is sent to PLD U512, which in turn control the digital attenuator to control the power. The temperature compensated detector enables the power to be controlled within +/-1 decibel over the operating temperature range. PA U12 is capable of delivering up to 29 dBm power.

8 Couplers

- a The RF output of the power amplifier U12 is on U12-12. The output is routed through three 23-decibel couplers and one 33-decibel coupler. The three 23 decibel coupled signals are used for Receive Mixer LO U12, Cal Mixer LO U11 and for calibration signal generation using BAW device U6. 33 decibel coupler is used to sample the output signal and feed back to the PFD U33 through frequency dividers U21 & U25. There exist two more 23 decibel couplers for test signal injection before LNA, U7.
- b Each directional coupler consists of two microstrip coupled lines with a gap dimension of which depends on the coupling requirements. The coupling length is quarter wavelength and one port of each directional coupler is terminated by 50 ohm shielded resistors (R10, R36, R88, R89, R90, R121). The printed structure of coupler provides 0.25 decibel maximum loss.

9 Isolator

- a An isolator, U17 is placed between the Power Amplifier and the Transmit antenna to minimize reflections from the transmit antenna and associated cables and connectors and improve the VSWR. This is a SMT device and provides 20 decibel minimum isolation with 0.5 decibel of maximum insertion loss.

10 Low-Pass Filter

- a A printed microstrip low pass filter is employed to attenuate the harmonics up to 18 gigahertz. This filter provides 30 decibel and 15 decibel for 2nd and 3rd harmonics respectively and a maximum insertion loss of 0.25 decibel. The return loss of this filter is better than 18 decibel. The output of the low-pass filter is routed to transmit antenna connector J1004-1.

11 DC block and the Transguards

- a A high-voltage matched capacitor circuitry and transguard are used in the transmitter chain to provide protection transmitter amplifier and the DC antenna monitoring circuit from voltage transients which are caused by lightning.

12 RF FPGA

- a The FPGA supports a 24 bit serial interface between the DSP and RF module. The DSP uses the DATA_IN and DATA_CLK signals to transfer 24 bit serial data sequences to the FPGA that provide it with

EFFECTIVITY _____

ALL

34-42-37

Page 19
10 Oct 2007

Honeywell

COMPONENT MAINTENANCE MANUAL

Part No. 066-50007

- system select information, control the U1 Receive RF switch with the RX_SWT_CTRL signal, control the U3 Calibration RF switch with the CAL_SWT_CTRL signal and control power to the U7 LNA with the RF_AGC signal. The FPGA returns received DATA_IN data on the DATA_OUT line when RDATA_EN is low and the FSYNC signal when RDATA_EN is high.
- b The FPGA generates the FSYNC and DOWN_UP signals based on the system select information provided by the 24 bit serial interface. The frequency of the DOWN_UP signal is 145 Hz for system select 1, 150 Hz for system select 2 and 155 Hz for system select 3. The FSYNC frequencies are one-half the DOWN_UP frequencies. Assertion of the RAMP_CLR signal cause the FSYNC and DOWN_UP signals to be held low.
 - c The FPGA gets ramp rate information by reading ADC U510 using the A2D_CS, A2D_SCLK and A2D_DOUT signals. The ADC input is the DAC12_0 signal and its voltage is proportional to the ramp rate required by the DSP.
 - d The FPGA programs the main DDS U32 using the DDS1_CS, DDS1_SDIO and DDS1_SCLK signals. The DDS1_SDO signal provides the FPGA readback capability of the DDS internal registers. Signals DDS1_RESET and DDS1_IOSYNC are used to reset the DDS. Similar signals support the monitor DDS U18.
 - e Both DDS are programmed with identical ramp information based on system select and the ramp rate information from the ADC. For system select 1 the DDS are programmed such that the lower transmitter frequency is held constant at 4.235 gigahertz, for system select 2 the upper transmitter frequency is held constant at 4.365 gigahertz and for system select 3 the transmitter frequency range is held centered at 4.3 gigahertz.
 - f The FPGA FUD signal is used to initially program the DDS for a single 4.3 gigahertz transmitter frequency. During normal operation the FPGA PS0 signal is then used to program the DDS registers with new ramp rate and frequency range data. The PS0 signal also controls the ramp frequency direction of the DDS.
 - g The FPGA uses the TX_PWR_DET_LO and TX_PWR_DET_HI signals from comparator U514 to level the transmitter power. The FPGA periodically adjusts the TX_5dB_CTRL to TX_16dB_CTRL signal lines in .5 decibel steps until both TX_PWR_DET_LO and TX_PWR_DET_HI signals are high.
 - h The FPGA provides limited fault detection reporting to the main processor module via the FAULT_EB and FAULT_EF signals. Via the bite fault multiplexer U4 when the tri-state FAULT_EB signal is pulled low the LRU will generate an EB fault and similarly polarity changes in FAULT_EF signal will cause the LRU to report an EF fault. Only when

EFFECTIVITY _____

ALL

34-42-37

Page 20
10 Oct 2007

Honeywell

COMPONENT MAINTENANCE MANUAL

Part No. 066-50007

the RF_AGC signals at FPGA pins 27 and 24 miss-compare will the EF fault be generated. Transmitter leveling faults, miss-compare faults between the two DDS outputs, 384 megahertz clock frequency or 20 megahertz clock frequency(G500) accuracy faults, or transmitter PLL loop faults occurring when the PLL_LOCK_DET signal goes low cause the EB fault to be generated.

(3) Receiver Chain

(a) The heart of the receiver chain is the double balanced mixer. The signal received from the Rx Antenna is mixed with a sample of the transmitter signal to produce a low frequency signal that is proportional to the altitude to the ground. An LNA with bypass switch is employed to adjust the LNA gain between the two states as required by the received signal amplitude.

1 DC block and Receive Transguards

a The BPF provides the required dc block for the receiver chain while the transguard provides protection for the antenna monitoring circuit from voltage transients which are caused by lightning.

2 Bandpass Filter

a The receiver input is from RX antenna connector J1005-1. The receive RF signal from the antenna is routed through a 4.3 gigahertz bandpass filter. This printed bandpass filter uses parallel coupled, half-wave long microstrip resonators, coupled along half of their length with the adjacent resonators. The seven-resonator bandpass filter provides 2.5 decibel loss in the bandpass and 50 decibel attenuation for the multilayer spiral parasitic signal at 5.03 gigahertz and overall out of band attenuation to reject out of band HIRF up to 18 gigahertz.

3 Receive/Calibration switches

a The output of the bandpass filter is routed to the LNA through the RF switch U1. The RF switch U1 is a broadband high isolation, non-reflective SPDT. The receiver and calibration switches (U1 and U3) provide the facility to channel the appropriate signal through the receiver chain and are used for the self-test and noise floor test. The switches are non-reflective, high isolation switches and provides about 50 decibel of isolation at 4.3 gigahertz with 1.5 decibel insertion loss. The high isolation on the PCB is achieved through co-planner wave guide design instead of microstrip.

b The RF switch operates with complementary negative control voltage logic of -5 to 0 V dc and does not need bias supply. Control signals are generated by the PLD through CMOS level shifters (U2) since the PLD operates with 3.3volts. The switch control voltages are also being monitored by the MUX U4.

c The control of the RF switch is by the control signals on U1-15 and -16. Refer to Table 6 for the U1 control truth table. The RF1 output is not used and grounded through resistor R5.

EFFECTIVITY _____

ALL

34-42-37

Page 21
10 Oct 2007

Honeywell

COMPONENT MAINTENANCE MANUAL

Part No. 066-50007

Table 6. U1 Control Truth Table

Control Input		Signal Path State	
U1-16 (A)	U1-15 (B)	RFC to RF1	RFC to RF2
High	Low	On	Off
Low	High	Off	On

4 Low Noise Amplifier/Step Attenuator

a The receiver front-end C-Band low noise amplifier, U7 has a typical noise figure of 1.8 decibel and provides 12 decibel of gain for lower level signals (high altitudes), and 6 decibel attenuation (total loss 18 decibel) for the higher level signals (low altitudes). The amplifier is under the binary control of the PLD U512. The low noise amplifier insures with minimum noise figure for signals received at high altitudes.

5 RX Mixer

a The receive mixer (U10) is a double balanced mixer with built-in LO amplifier and work with +2 dBm of typical LO signal. This provides 8 decibels of conversion loss, 32 decibels LO/RF isolation, and 25 decibels LO/IF isolation. In the receive path, the RF signal on U10-8 is from the Rx antenna through the RF Switch U1. The LO signal to U10-1 is from the 23 decibels coupler on the output of the power amplifier U12-12. The two signals are mixed to provide the IF baseband signal (IF_TO_BB) on U10-5.

(4) Cal Signal Chain

(a) A directional coupler picks off some of the transmitter signal and feeds it to a bulk acoustic wave device that provides a reflected signal calibrated to a time delay equivalent to 300 feet (0.616usec). Calibration mixer extracts a signal at the difference frequency between transmit and delay element signals. The output is filtered and amplified and processed by the CPU for calibration and self-test purposes.

1 Delay-Line

a The 300-foot Bulk acoustic wave SMT delay line U6 with 0.603 to 0.616 usec delay consists of a cylindrical rod of quartz crystal for the propagation of an acoustic wave. This one- port delay line uses only one transducer for both input and output and therefore we have included a circulator that properly directs the input to the BAW and output of the delayed signal to the calibration mixer. The circulator prevents the transmitter sample signal from directly being applied to the calibration mixer. The BAW delayed signal incurs 28 to 38 decibels of insertion loss at 4.3 gigahertz.

2 Circulator

a The circulator, U5 is a counterclockwise SMT device and provides 22 decibels minimum isolation at 0.5 decibels maximum insertion loss. A

Honeywell

COMPONENT MAINTENANCE MANUAL

Part No. 066-50007

portion of the transmit signal is supplied to port-1, which in turn feeds the delay-line at port-2 to produce the delayed signal. The reflected signal is extracted from port-3 and fed to the cal mixer.

3 Calibration Mixer

- a The device used for calibration mixer U11 is the same as receive mixer U10. In the calibration path, the RF signal on U11-8 is from the circulator U5 output. The LO signal, CAL_LO_MIX on U11-1 is from the 23 decibels coupler on the output of the power amplifier U12-12. The two signals are mixed to supply the IF calibration baseband signal (CAL_TO_BB) on U11-5.

(5) IF Sections

- (a) U506, U507, and U505 are the calibration output amplifier chain. U506 acts as a selectable high-pass filter controlled by HI_PASS1 and HI_PASS2 signals which comes from the DSP. In the case of the calibration signal, it allows for increased high pass filtering in the response to the calibration IF. With switch 2 (S2) of U506 open, C532 is not part of the circuit and the high pass response is determined by C533. With S2 closed, C532 is then in parallel with C533 and is the dominant factor in determining the response of the input stage of the filter.
- (b) The input signal CAL_TO_BB goes through C533, which gives it a high-pass response. The signal then goes into U507 which is a non-inverting amplifier with a gain of 20.
- (c) The output of U507 goes to C534 which produces a high-pass response. This is also selectable by HI_PASS2. With switch 4 (S4) of U506 open, R66 is not part of the circuit and the response is determined by C534 and R536. With S4 closed, the response is determined by C534 and the parallel combination of R536 and R66 to determine the cutoff frequencies/response. The output goes to U504, which is an inverting amplifier with a gain of 2. This gain can be adjusted using the pot R34. Next, the output goes through C512 for high-pass filtering and becomes CAL_OUT, which goes to the differential amplifiers in the DSP section.
- (d) The IF input signal IF_TO_BB is ac coupled to transistor Q1, which is a common emitter amplifier. The output from the collector of Q1 is filtered by C36 (low-pass) and C528 (high-pass) and then it is applied to high-pass amplifier U505. Overall, Q1 and U505 have 30 decibels of gain and low noise. The output of U505 goes through R533 and then into a selectable high-pass filters which is determined by HI_PASS1 and U506. With switch 1 (S1) and U505 open, C45 is not part of the circuit and the response is determined by C531 and the input impedance of U502 which is 100-ohms. With S1 closed, C45 is in parallel with C531 and becomes the dominant capacitor for the response. The response is essentially C45 and 100 ohms. The output of the high-pass filter goes to U502-A, which is a 40 decibels gain voltage controlled amplifier. It is controlled by the IF_AGC which comes in on pin 28 of J21. The voltage at pin 16 of U502-A and pin 9 of U502-B varies from 0 to 2.5 volts.
- (e) The gain of U502 can varied from 0 decibel gain to 40 decibels gain. The output of U502-A goes through a high-pass filter (C505) and then it is routed to the pin

EFFECTIVITY _____

ALL

34-42-37

Page 23
10 Oct 2007

Honeywell

COMPONENT MAINTENANCE MANUAL

Part No. 066-50007

7 of U502-B. U502-B is a 0 to 40 decibels voltage controlled amplifier. Its gain goes from 0 to 40 decibels gain when the input on pin 9 goes from 1.25 to 2.5 volts. Overall, from pin 2 of U502-A to pin 11 of U502-B, there is up to 80 decibels gain available depends up on the IF_AGC control signal. The output is low-pass filtered through R503 and C503 and goes into the first of two switched capacitor filters.

- (f) U500 and U501 are switched capacitor elliptical filters which have a response equivalent to an eight-pole elliptical filter. The cutoff is determined by the FILTER_CLK which comes from the DSP section. The cutoff is at 43 KHz. The output of these filters have an uncommitted op-amp with which resistors R1, R2, R3, and capacitors C1 and C2, are a dual, two-pole low-pass filter to reduce the amount of clock noise on the output. The output of U500 is connected to U501, which is essentially the same circuit, to give it a very sharp cut-off to prevent high frequencies going to the DSP. The output at pin 5 of U501 goes through high-pass filter C507 to pin 3 of amplifier U503 which has a gain of 15 decibels. The output of U503 goes through R22 and is the BASEBAND_OUT which goes to the DSP section.

(6) BITE MUX

- (a) The BITE MUX U4 is a CMOS latched 16-bit to 1 analog multiplexer. The BITE MUX has different voltages on its inputs which are monitored by the DSP section. On input 1 (S1) and 2 (S2), 2.5V and 3.3 volts going to the RF section are monitored. Also, input 2 (S2) provides FAULT_EB signal which can be decoded to a set of RF circuitry failures. Inputs 3 (S3) thru 4 (S8) are the RX_SWT_CNTRL signal voltage which is monitored. Input 7 (S7) is the FAULT_EF signal voltage which is monitored. Input 7 (S6) is the CAL_SWT_CNTRL signal voltage which is monitored. Input 8 (S8) is the RF_AGC signal voltage which is monitored. Input 9 (S9) is the +12_DIG volts which is monitored. Input 10 (S10) is the +5V_RF which is monitored. Input 11 (S11) is the -12_DIG volts which is monitored. Input 12 (S12) is the -5_DIG volts which is monitored. Input 13 (S13) is the TX_ANT_MON which is monitored and should look like a short when connected to an antenna. Input 14 (S14) is the RX_ANT_MON which is monitored and should look like a short if its connected. Input 15 (S15) is the RAMP_OFFSET signal voltage which is monitored. Input 16 (S16) is the TX_POWER_MON which is monitored. U508-A is a buffer amplifier to buffer the output going to the DSP section.

(7) Power Supply Filtering

- (a) The power supply filtering consists of L507, L501, L505, and L504. RF CCA contains voltage regulators U13, U16, U22, U23, U29, U30, U34, U509 & U515 linear regulators to generate a clean +1.8V, +2.5V, +3.3V, +5.0V, +10V, and -5V for various RF and Digital ICs. U5 is switching regulator to convert 12V to +6V DC with 85 percent efficiency. This device contains internal short circuit protection also.

EFFECTIVITY _____

ALL

34-42-37

Page 24
10 Oct 2007

Honeywell

COMPONENT MAINTENANCE MANUAL

Part No. 066-50007

C. Main Processor Module (Subtask 34-42-37-870-011-A01)

(1) General

- (a) See Figure 2004 (GRAPHIC 34-42-37-99B-814-A01) for a schematic diagram on the Main Processor Module.
- (b) The main processor module:
 - Controls the radio altimeter operation
 - Does signal processing of the difference frequency and test signals
 - Controls the aircraft interfaces and the data displayed on the front panel.
- (c) The main processor module is divided into three major sections:
 - 486 microprocessor section
 - I/O section
 - DSP section.

(2) 486 Microprocessor Section

(a) General

- 1 The 486 microprocessor section (CPU section) does frame-to-frame processing of the altitude data from the DSP section and supplies the altitude to the I/O section. Programmable logic devices serve as the microprocessor controllers and are the interfaces to:
 - Memory devices (boot routine, program, fault, and data)
 - Data recorder/data loader flash card
 - Front panel display driver.
- 2 The microprocessor U39, in the CPU section, controls all major functions of the radio altimeter. Microprocessor U39 is an Intel® 486 SX microprocessor, which does not have a math coprocessor. The CLK signal on U39-123 is the fundamental timer and the internal operational frequency for the microprocessor.
- 3 Address lines A31 thru A2, together with the byte enables BE0* thru BE3*, define the physical area of memory or I/O space accessed. Address lines A31 thru A4 (2) are used to drive addresses into the microprocessor to do cache line validations. Address lines A31 thru A2 are not driven during bus or address hold. The byte enable signals BE0* thru BE3* indicate active bytes during read and write cycles.
- 4 On the first cycle of a cache fill, the external system assumes that all byte enables are active. Data lines D31 thru D0 are the data lines for the microprocessor U39. Data lines D0 thru D7 define the least significant byte of the data bus while lines D24 thru D31 define the most significant byte of the data bus. Data parity pins DP0 thru DP3 are connected to VCC through pull-up resistors because the system does not use parity.

EFFECTIVITY _____

ALL

34-42-37

Page 25
10 Oct 2007

Honeywell

COMPONENT MAINTENANCE MANUAL

Part No. 066-50007

- 5 A temperature sensor is used for the data log for temperature. It is for BIT and is used to log the temperature when a failure happens. This is used in debug.
- (b) Microprocessor Control
- 1 Programmable logic device U52 and integrated peripheral controller U22 are the heart of the Main Processor CCA. The bus controller U52 has all the logic signals and timing needed to do chip selects and control microprocessor U39. Oscillator Y1 is a 24 megahertz clock, which is divided by 2. This supplies 12 megahertz to microprocessor U39. The 24 megahertz is used because there are two edges used to control the timing.
- 2 The 5-volt monitor and watchdog timer U28 reset gives over and under voltage protection. It is set for about 5 to 7 percent of the upper 5 volts, which is needed for the microprocessor U39. When the voltage falls below 4.75 volts or rises above 5.25 volts, the reset happens and holds the microprocessor in reset.
- 3 Crystal G2, on integrated peripheral controller U22-72, is a 32.768 kilohertz crystal. It is used to control the real time clock for the software. It also controls timing and tagging information.
- (c) Microprocessor Memory
- 1 Data RAMs U40, U47, U53 and U61 are 128K X 32 CMOS static RAMs. The data RAMs are backed up by +5 Volts for 20 seconds, which decreases power-up time. The chip select, on pin 22 of each device, is used to make sure there are no inadvertent writes to each RAM. The chip selects are held high to disable the RAM as the power goes down. This makes sure that no exterior writes happen to the RAM.
- 2 Flash memories U16, U17, U25, and U26, are used to store the program. These memories are read/write and can be rewritten as long as 12 volts is applied to the device. The flash memories 12-volt switch circuit consists of transistor Q6 and the associated components. The flash memories 12-volt switch is controlled to make sure that no inadvertent writes happen during operation. It is a switch needed to turn on the 12 Volts to the flash memory.
- 3 Devices U2, U3, U9 and U10 are the byte swapping logic. There are two independent buses to accommodate 32-bit and 16/8 bit devices. The FAST 32-bit bus only talks with the program/data memories. The SLOW bus talks to all other I/O peripherals. For the 32-bit microprocessor U39 to talk to any 8- or 16-bit devices, the 16- and 8-bit memories need external byte swapping logic to route data to the appropriate data lines. Separate buses distribute capacitance loading and thus lower signal noise.
- 4 Devices U4, U11 and U60 are address buffers. Half of U11 is used to buffer other signals for increased drive and to make sure that the signals are clean going to other sections of the module. Address buffer U60 is the control signals buffer, which is all the signals that go to either the I/O section or the DSP section. The signals are pulled up to make sure that no noise gets on the line and inadvertently actuates the signal.

EFFECTIVITY _____

ALL

34-42-37

Page 26
10 Oct 2007

Honeywell

COMPONENT MAINTENANCE MANUAL

Part No. 066-50007

- 5 The D flip-flops U42 and U48 are used in the I/O discretes circuit. On U48, the FLASH_WR_ENABLE discrete is used to switch 12 volts. The DSP_RESET discrete and RS232_RST discrete are used on two different peripherals. Another discrete is the LCD_LITE_EN, which turns on the backlight on a plug-in test display. Device U42 makes up the input discretes, which monitor various inputs from the data card and some of the test buttons from the front panel.
- 6 Device U59 is a 32K byte CMOS EEPROM. This is the storage site for configuration memory and fault memory recorded during the flight legs.
- 7 The BOOT block flash memory U50 is where microprocessor U39 gets the start-up information and power up. Device U50 is a 128K X 8 flash memory and a switch. The switch has two settings: SHOP_MODE and NORMAL_MODE. The flash memories are not preprogrammed.
- In the SHOP_MODE, the switch lets 12 volts access the BOOT block section. This is done so that in flight (even if the 12 volts is inadvertently turned on) the BOOT code can not be overridden. It can only be done in the shop and the unit has to be open.
 - In the NORMAL_MODE, part of the BOOT code can be overridden but that is not essential to the unit so memory cannot be lost.
- 8 A UART U65 does parallel-to-serial conversion on data characters received from the microprocessor. The microprocessor can read the complete status of the UART U65 at any time during the functional operation. When CS0 and CS1 are high and CS2 is low, the chip is selected. This enables communication between the UART and the microprocessor.
- 9 When the interrupt output pin U65-33 goes high when any one of the following interrupt types has an active high condition and is enabled through the interrupt enable register:
- Receiver Line Status
 - Received Data Available
 - Transmitter Holding Register Empty
 - MODEM Status.
- 10 The INTR signal is reset low upon the appropriate interrupt service or a master reset operation.
- 11 Connector J8 is the 34-pin power supply connector. The +24, +5, +12, and -12 volts have filter capacitors and inductors. The PWRDN_INT* signal on J8-4 is buffered by two Schmitt trigger inverters and a pull-up resistor and capacitor. This is the power supply signal that tells the unit that the 200 milliseconds power hold-up is about to go down, and to store all the information before all power is lost.
- 12 Connector J12 is the in-circuit programmable connector. This connector is used to program microprocessor U52 and U70, the circuit card PLDs.

EFFECTIVITY

ALL

34-42-37

Page 27
10 Oct 2007

Honeywell

COMPONENT MAINTENANCE MANUAL

Part No. 066-50007

Microprocessor U52 and U70 can be reprogrammed as many times as needed.

(3) I/O Section

(a) General

- 1 The I/O section of the Main Processor Module supplies the necessary signal level conversion, bipolar to TTL and TTL to bipolar. The I/O section also does the serial to parallel and parallel to serial conversion needed to transfer ARINC 429 and discrete input/output information between the I/O module and the main processor data bus.

(b) ARINC 429 Inputs

- 1 The ARINC 429 receivers 1 and 2 are in U20. The ARINC 429 receivers 3 and 4 are in U27. The ARINC 429 receivers 1, 2, 3 and 4 are dual 429 receivers used to convert the bipolar input signals from standard 429 levels (+12 to -12 V dc) to standard TTL levels (0 to +5 V dc) needed for proper operation.
- 2 There are four ARINC 429 inputs to ARINC 429 receivers 1 and 2, U20. They are:
 - `FREQ_FUN_SEL INPUT_PORTA_A` (J6-41)
 - `FREQ_FUN_SEL INPUT_PORTA_B` (J6-42)
 - `FREQ_FUN_SEL INPUT_PORTB_A` (J6-49)
 - `FREQ_FUN_SEL INPUT_PORTB_B` (J6-50).
- 3 The TTL level serial data output from U20-5, -8, -12, -15 dual receiver U20 is applied to XCVR LSI U49-19, -20, -21, -22. The serial data is shifted into internal registers and stored as 8-bit parallel bytes. When a valid word is received, a processor interrupt IOINT signal is asserted at U49-27.
- 4 The microprocessor U39 responds to this interrupt by the addresses SA2 and SA3 on U49-6 and -7. Signal IOCS1 on U49-5 is asserted low. The W/R SA4 signal on U49-2 is asserted high. This selects U49 and the data byte is placed onto the IO_DATA bus (D0-D7) The D0-D7 I/O data bus lines are applied to the lower section of bidirectional 429 data buffer U37, which interfaces XCVR LSI U49 to the microprocessor slow data bus.
- 5 The ARINC 429 receivers 3 and 4 operate the same as the ARINC 429 receivers 1 and 2 and are not described.

(c) ARINC 429 Outputs

- 1 There are two ARINC transmitters on the Main Processor CCA. ARINC 429 transmitter 1 is U66. ARINC 429 transmitter 2 is U67. The outputs of transmitter 1 are `CMC_OUTPUT_A` and `CMC_OUTPUT_B` on J6-61 and -62. The outputs of transmitter 2 are `429_OUTPUT_#0_A` and `429_OUTPUT_#0_B` on J6-55 and -56. Because 429 signal processing is identical for both outputs, only transmitter 1, U66, is described.

EFFECTIVITY _____

ALL

34-42-37

Page 28
10 Oct 2007

Honeywell

COMPONENT MAINTENANCE MANUAL

Part No. 066-50007

- 2 To transmit, the main processor places a data byte on the I/O data bus through bidirectional 429 data buffer U37. Bidirectional 429 data buffer U37 addresses and selects 429 LSI #1 U49 and asserts WR low. The data byte present at the data inputs to U37, is clocked out as a serial TTL level data bit stream from LSI#1 U49-3 and -4. The serial data stream is applied to ARINC 429 transmitter U66-6 and -23. Transmitter U66 converts the TTL input to a bipolar output at U66-13 and -17. The bipolar output from U66 is routed through J6-61 and -62 to the rear interconnect board.
- 3 The bipolar output from U66-13 and -17 is also routed through multiplexer U56 and fed back as 429_BITE_INPUT_A and 429_BITE_INPUT_B to 429 receiver U27-4 and -6. The signal is converted to TTL levels and applied to LSI U49-25 and -26. This allows the main processor to read and verify the transmitted data.

(d) Discrete Inputs

- 1 The 16 discrete inputs from the rear interconnect module are applied to the main processor module at pins 15 thru 30 of connector J6. Eight of the 16 input lines are applied to the inputs of discrete input latch U38 through diode networks and resistor divider network R36. The other eight lines are applied to discrete input latch U38 through diode network and resistor divider network RR27. The outputs from discrete input latch U38 are placed directly on the microprocessor slow data bus.
- 2 Resistor divider networks R27 and R36 lower the bipolar level signals to TTL levels. The diode networks supply over-voltage protection for the U38 inputs.

(e) Discrete Outputs

- 1 Discrete output data is placed on the microprocessor slow data bus and applied discrete output/429 TX setup latch U69. The data is latched and transferred to the 1Q and 2Q outputs of U69. The control signals TX1EN and IOCS5 at U69-25 and -48 are asserted. The 1Q outputs of U69 are used as strobe and sync pulses to select 429 transmitters 1 thru 4 on the I/O control bus.
- 2 The 2Q outputs are the discrete data lines, which are applied to power driver U32. The 2Q outputs from power driver U32 are unregulated 24-volt signal levels that are transmitted to the rear interconnect module through connector J6.

(f) Shut Down Logic

- 1 Two discrete are present on the rear connector, but are not connected internally. The unit is strapped for interrupt mode. One discrete is strapped high the other discrete is strapped low. In the interrupt mode the high and low discrete is applied through a diode network and resistor divider network R27 to the A and B sections of logic gate U68 where it is inverted to produce a high INT_ENABLE signal on I/O control bus. Logic gate U68 inverts the high signal back to its original low status before it is latched into discrete input latch U38.

EFFECTIVITY _____

ALL

34-42-37

Page 29
10 Oct 2007

Honeywell

COMPONENT MAINTENANCE MANUAL

Part No. 066-50007

- 2 The high INT_ENABLE signal on I/O control bus is applied to the C and D sections of U68. The outputs of U68C and U68D are determined by the state of the MON1 and MON2 signals at pins 9 and 12. In normal operational conditions (no failures or errors detected), the MON1 and MON2 lines are low, and do not affect the operation of 429 transmitters U66 and U67.
- 3 If a failure is detected, the monitor processor may assert a high MON1 or a high MON2 signal, which produces a low output from U68C or U68D. These low outputs are applied to the CLOCK (pin 25) and SYNC (pin 4) inputs of 429 TX #1 U66 and 429 TX #2 U67 to shut down the transmitters.

(4) DSP Section

(a) General

- 1 See Figure 5 (GRAPHIC 34-42-37-99B-806-A01) for a block diagram of the DSP section. The DSP section is used to process the analog outputs from the RF module. The DSP section also generates some of the control signals to the RF module for:
 - Transmit modulation
 - Automatic gain control
 - Test signals.

(b) Analog Input Circuits

- 1 The baseband signal (DETRX1), which is the output from the RF on the RF control module, goes into differential amplifier U45A. Differential amplifier U45A buffers the output that goes to analog MUX U46-6. Differential amplifier U45B is another buffer on the same signal, which buffers the signal that goes to the monitor processor.
- 2 Differential amplifier U36A buffers the calibration output signal (DETRX2 from the RF control module. It buffers the signal going into analog MUX U46-7. Another differential amplifier is U36B, which buffers the calibration output signal goes to the monitor processor.
- 3 Multiplexer U46 is a CMOS latched eight channels-to-one analog multiplexer. It switches between the calibration output signal and the baseband signal or any of the other inputs. In normal operation U46 alternately samples the calibration output signal and the baseband signal. The output of U46 goes to U57, which is a 12-bit A/D converter. Converter U57 output is controlled by the MUX addresses 0 thru 2, which are generated by the DSP I/O controller U70.

(c) Analog to Digital Conversion Circuits

- 1 See Figure 6 (GRAPHIC 34-42-37-99B-807-A01) for a block diagram of the DSP section. The analog signals from the RF module are digitized in 12-bit A/D converter U57. The A/D converter is also used to monitor signals from the BITE test points on the RF module and the power supply voltages. The digitized data from the A/D converter is stored in FIFO memory devices U18 and U29, which are accessed by the DSP. The output of the FIFOs goes

EFFECTIVITY _____

ALL

34-42-37

Page 30
10 Oct 2007

Honeywell

COMPONENT MAINTENANCE MANUAL

Part No. 066-50007

to the DSP_DATA [31:0] bus where the microprocessor has access to the contents of the FIFO.

- 2 Another mode of operation is byte sampling. The microprocessor determines that it wants to look at either the RX_MUX on J10/J2-20 from the RF control module or the bit MUX U43. This allows the microprocessor to monitor different voltages. The BIT output has a MUX on the RF control module, which allows the microprocessor to monitor RF test points.
- 3 The BIT MUX U43 enables a monitor of the power supply voltages +24, +12, and -12 and also a loop back DAC output (DAC8_0). Inputs DSPBD0, 1 and 2 are used to determine which one of the inputs is monitored. The DSP U15 writes to a latch inside the MUX U43 to select which of the 8 inputs it is going to look at.

(d) DSP Memory Circuits

- 1 The output of the FIFOs U18 and U29 is accessed by U15, which is the DSP. The DSP processes the difference frequency and calibration frequency into altitude information
- 2 Memory devices U6, U7, U12, and U23 are 32 k X 8 SRAMs, which make up the program/data memory. These are zero wait state memories that use 15 nanosecond RAMs that are 32 k deep. This makes a 32 k by 32-bit RAM array where the program is stored after boot up.
- 3 Dual ported RAM U33 is a where the communications between the DSP and the main processor takes place. It is 4 k deep by 8-bit wide where by the main processor and DSP can access any location. It is partitioned so the DSP does not access the main processor portion of the RAM. This is where all the commands from the main processor go to the DSP, and the altitude spectrum data from the DSP goes to the main processor.

(e) Data Buffers and Latches

- 1 Device U44 is a 16-bit data bus buffer. This is divided into two 8-bit functions. The U44 (1A) and U44 (1B) function buffers the lower 8-bits of the data bus. On U44 (1B) there is a DSPD0 signal, which is not buffered, that passes through U44 and comes out as DSPBD0, which is buffered. The other function U44 (2A) and U44 (2B) reads the discrete inputs from the RF control module. RF1_FIN0 and RF2_FIN0 are functions, which are defined, on the RF control module.
- 2 Latch U35 is a 16-bit latch, which supplies latched outputs to the RF control module. Data outputs DSPBD0 thru DSPBD7 is the buffered data bus and DSPD8 thru DSPD15 is unbuffered data. Outputs DSPL0 thru DSPL15 go through 5 megahertz low pass filters U14 and U58. They are then routed to the two connectors going to the RF control module.

(f) Digital to Analog Circuits

- 1 DAC U41 is a quad 8-bit device. Output 0 of U41 goes through another filter U30 and is routed to the RF control module on connector J10-28, as IF AGC voltage. This voltage allows the DSP to control the gain of the receiver IF.

EFFECTIVITY _____

ALL

34-42-37

Page 31
10 Oct 2007

Honeywell

COMPONENT MAINTENANCE MANUAL

Part No. 066-50007

Output 2 goes out on J10-22, which is RAMP_REF. Each D/A converter output VOUTA for example, is addressed by setting DSPA0 and DSPA1 to a zero and then writes the value on the DSP data bus (the lowest seven bits). Then VOUTB writes a one to A0 and a zero to A1, and then writes the value.

- 2 DAC U24 is a quad 12-bit device. The value for the output is written on the data line D0 thru D11. Each output is accessed by:
 - A write to an address A0 or A1
 - Selection of one output
 - Placement of the value on the data bus outputs.
- 3 Digital-to-analog converter U24 is double buffered on the input, so there is a LDAC function (U24-7), which is controlled by the I/O controller U70. When the microprocessor writes to the latch, it goes through an input latch. When the LDAC goes low, the input latch is written to the output. This function is there so that all the outputs are synchronized. Each of these outputs goes to quad SPST analog switch U19.
- 4 Quad SPST analog switch U19 along with U13 make up a quad sample and hold circuit. When the DAC changes voltage, the switch U19 opens and the capacitors hold the previous value. Once the DAC settles out, U19 closes and samples the output of the DAC. Device U13 is a quad op-amp buffer for the capacitors. These outputs go to U30, which is a low pass filter. Output VOUTA from the DAC, after it is sampled, goes to the RF control module and is used for the RAMP_REF on the RF control module.

(g) DSP Control

- 1 The I/O controller U70 is a high-density in- CPLD. It is programmed by the JTAG inputs, which go to a connector on the main microprocessor.
- 2 This I/O controller CPLD U70 has many functions, one is to control which input is sampled, like the analog MUX U46 on the input. The main processor generates a timer clock, which is DSPCLK1. The DSPCLK1 controls the sample rate of the analog-to-digital converters.
- 3 The DSPCLK1 goes into a state machine in the I/O controller U70. The I/O controller U70 generates the address to be sampled and the sample command SAMPLE. This goes to the input signal MUX U46 and to the 12 BIT A/D converter U57. The I/O controller U70 generates an A/DSC signal. The A/DSC* goes to the A/D converter which starts the conversion.
- 4 The MUX address lines 0 thru 2 determine which input is sampled. The A/D converter U57 has an end-of-conversion output, which goes high when the conversion is over. The I/O controller U70 generates an A/DOE signal, which goes to the FIFOs U18 and U29 where the DSP can read them.
- 5 Another function of the I/O controller U70, based on the timer clock DSPCLK1, is to generate a sample command. The sample command goes to the analog switch U19, which tells it when to sample the output of the 12-bit DAC U22.

EFFECTIVITY

ALL

34-42-37

Page 32
10 Oct 2007

Honeywell

COMPONENT MAINTENANCE MANUAL

Part No. 066-50007

- 6 Another function is chip select generation, which is `_CS0` thru `_CS8`. These are decodes of the address inputs `DSPA0` thru `DSPA4` and `DSPA20` thru `DSPA23`, to generate `DSPCS0` thru `DSPCS8`. Another function tied to the timer clock `DSPCLK1` is `LDAC`, which, is the command to load the output latch of the 12-bit DAC `U24`.
- 7 Another function of the I/O controller `U70` is to generate the serial clock out (`SCLKOUT`) and serial data out (`SDATOUT`) signals. The signals go to the RF control module. On the serial port from the DSP the frame is ANDed with the clock to generate a gated clock on `SCLKOUT`. The gated clock on `SCLKOUT` signal is routed with `SDATOUT` through low pass filters `U31` and `U64`.
- 8 The `SCLKOUT` signal is used to load the ramp generator with the ramp value to be used in that sweep. It lets the read back of the `DATA_OUT_FSYNC`. The data is then read back through input that goes into the I/O controller `U70` (`SD2IN`). It is put onto the `RX_CLK`, `RX_FRAME`, and `RX_DATA` so verification of data sent out was loaded properly into the ramp generator.

EFFECTIVITY _____

ALL

34-42-37

Page 33
10 Oct 2007

Honeywell

COMPONENT MAINTENANCE MANUAL

Part No. 066-50007

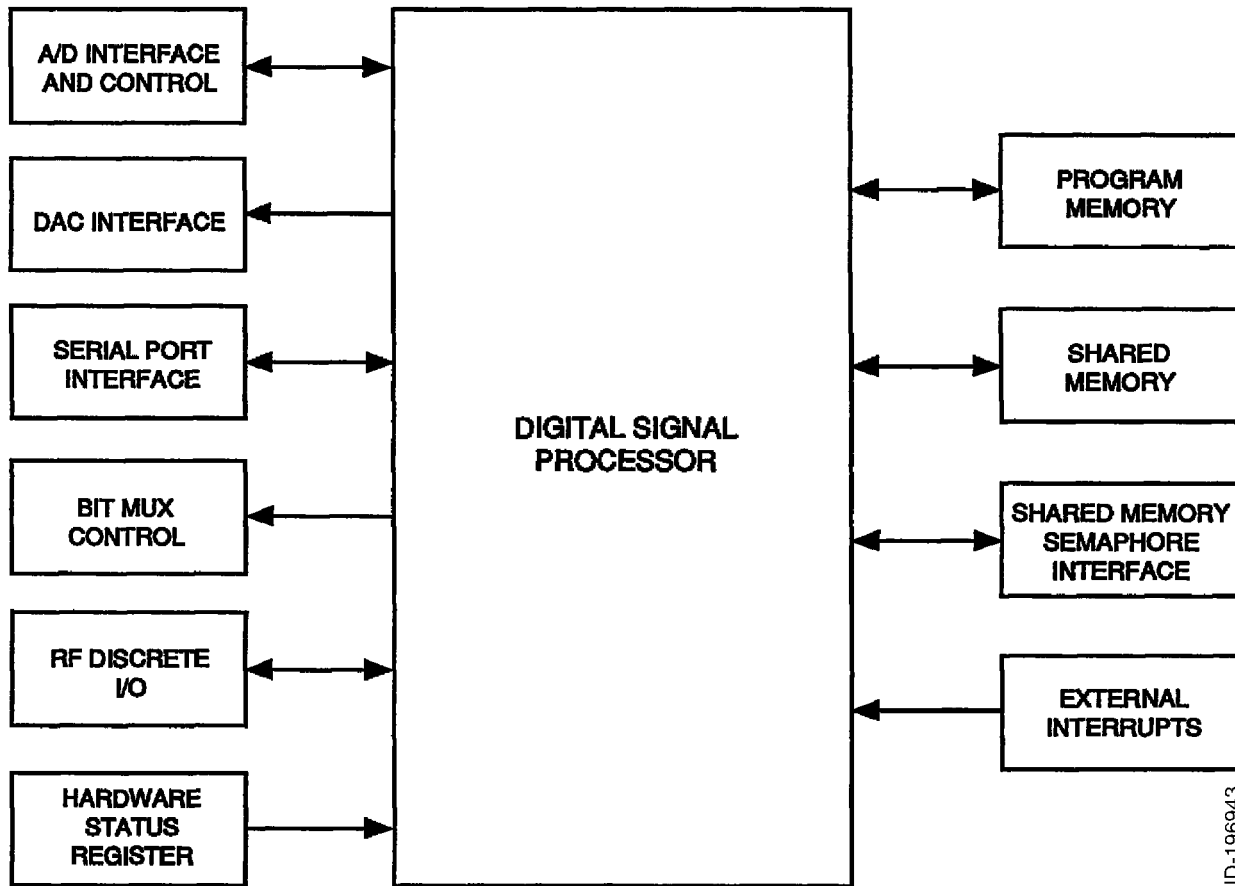

Figure 5. (Sheet 1 of 1) DSP Block Diagram (GRAPHIC 34-42-37-99B-806-A01)

EFFECTIVITY _____
ALL

34-42-37

Page 34
10 Oct 2007

Honeywell

COMPONENT MAINTENANCE MANUAL

Part No. 066-50007

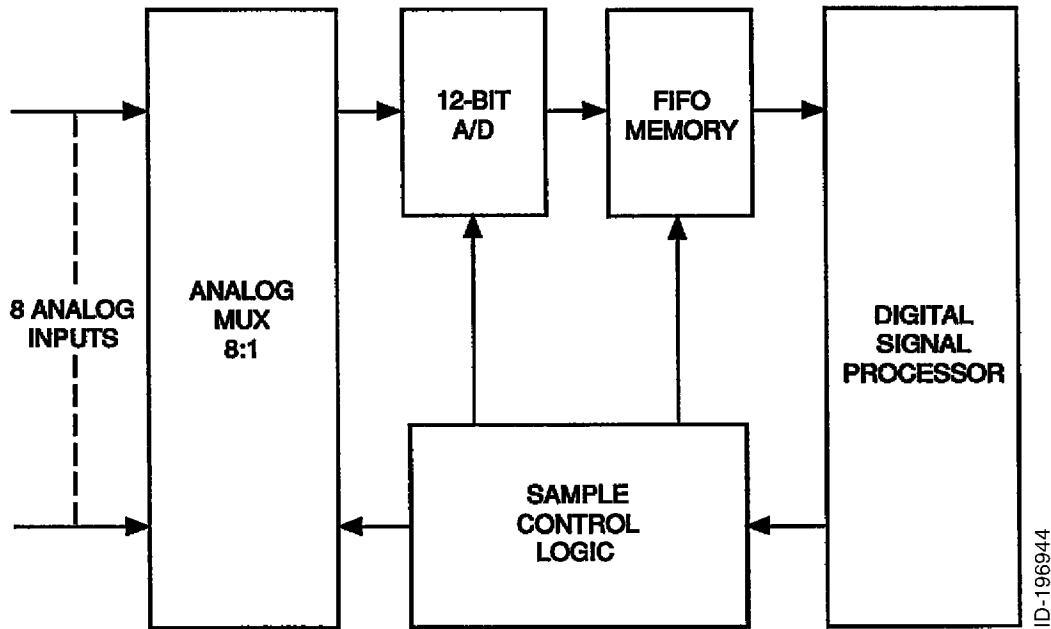

Figure 6. (Sheet 1 of 1) Input Filter Module (GRAPHIC 34-42-37-99B-807-A01)

EFFECTIVITY _____
ALL

34-42-37

Page 35
10 Oct 2007

Honeywell

COMPONENT MAINTENANCE MANUAL

Part No. 066-50007

D. Monitor Processor Module (Subtask 34-42-37-870-012-A01)

(1) General

- (a) The main component of the monitor processor module is the Monitor Processor CCA. See Figure 2003 (GRAPHIC 34-42-37-99B-813-A01) for the schematic diagram of the monitor processor CCA. See Figure 7 (GRAPHIC 34-42-37-99B-808-A01) for the overall block diagram of the monitor processor CCA.
- (b) The Monitor Processor CCA supplies a second signal processor path. It uses a DSP. The DSP processes the received signal and calibration signal, supplied in digital form, from the main processor A/D converter. Also present are a clock, an ARINC 429 receiver/selector, and static memory.
- (c) The Monitor Processor CCA monitors how the main processor module processes the signals. There are three interfaces between the main processor module and the Monitor Processor CCA:
 - Shared memory interface
 - 429 interface
 - DSP serial interface.

EFFECTIVITY _____

ALL

34-42-37

Page 36
10 Oct 2007

Honeywell

COMPONENT MAINTENANCE MANUAL

Part No. 066-50007

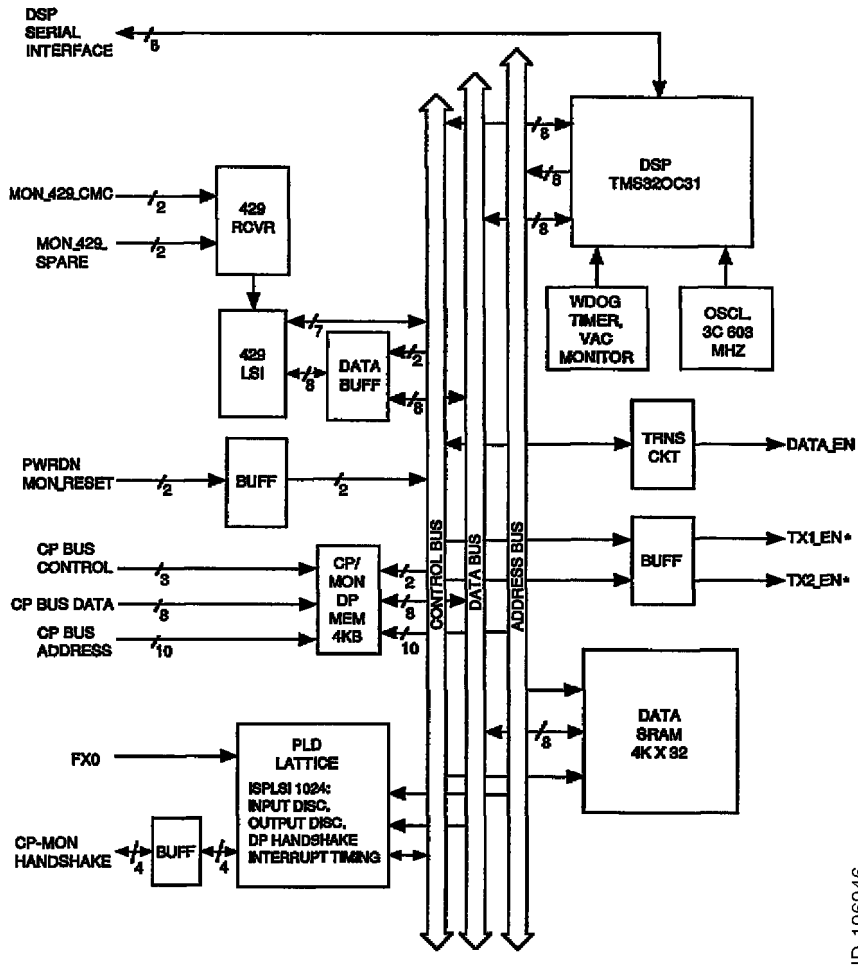

Figure 7. (Sheet 1 of 1) Monitor Processor Block Diagram (GRAPHIC 34-42-37-99B-808-A01)

EFFECTIVITY _____
ALL

34-42-37

Honeywell

COMPONENT MAINTENANCE MANUAL

Part No. 066-50007

(2) Shared Memory Interface

- (a) The shared memory on the Monitor Processor CCA is the interface to the main processor module. Two hardware semaphores located in the programmable logic device U1 supply control of the interface. There is no nonvolatile memory on the monitor processor module.
- (b) The Monitor Processor CCA gets the program through the shared memory interface, which is dual port RAM U1. After power-up the signal MON_RESET (U11-48) is held active. The main processor module loads the monitor program in the shared memory. Then the main processor takes the monitor out of reset, which causes MON_RESET to go high. The DSP automatically loads its program to the static RAMs U5, U6, U8, and U9.
- (c) Programmable logic device U11 is a logic device, which is programmed on the module by connector J6043 connector. Figure 8 (GRAPHIC 34-42-37-99B-809-A01) is a block diagram of U11.
- (d) Inside the programmable logic device U11 device are:
 - Reset logic function
 - Interrupt timing
 - Input discrete
 - Output discrete
 - Chip select generation for the ARINC 429 and dual port RAM
 - ARINC 429 interfaces
 - Data enable and address lines LA2, LA3 and LA4
 - Watchdog timer logic
 - Boot ready logic
 - Shared memory logic.
- (e) The communications for the shared memory is done with two flip-flops implemented in the programmable logic device as shown in Figure 8 (GRAPHIC 34-42-37-99B-809-A01). The signal definitions are as follows:
 - 1 CM_REQ — CP to MON Request
 - Input pulse from CP
 - Latched to generate CM_IRQ.
 - 2 CM_IRQ — CP to MON Interrupt
 - Active high interrupt to MON, generated from CM_REQ signal from CP
 - Routed to CP/MON connector to be read by CP before next message is sent
 - Can also be read by MON as Input Discrete Bit DO
 - Cleared by CM_REL.
 - 3 CM_REL — Clear CP to MON Interrupt

EFFECTIVITY

ALL

34-42-37

Page 38
10 Oct 2007

Honeywell

COMPONENT MAINTENANCE MANUAL

Part No. 066-50007

- Any write to Address 60 0000C or reset clears the CP to MON interrupt.
- 4 MC_REQ — MON to CP Request
- Any write to Address 60 0010 sets MON to CP Interrupt.
- 5 MC_IRQ — MON to CP Interrupt
- Active high interrupt to CP, sent through CP/MON connector
 - Read by MON before next message is sent as D1 of Input Discretes
 - Generated by MC_REQ, cleared by MC_REL.
- 6 MC_REL — Clear MON to CP Interrupt
- Input pulse from CP/MON connector clears MON to CP Interrupt
 - Reset also clears the interrupt.
- (f) Each flip-flop has a request, clear, and a latched output. The latch of the communication from main processor to monitor processor has a CM prefix on the signal (control to monitor). In the other direction, the flip-flop has a MC prefix on the signal (monitor to main). CM_IRQ and MC_IRQ are the latched outputs.
- (g) When the main processor requests attention from the monitor processor CCA, it sends a request signal CM_REQ to the input U11-3. The signal is then latched and becomes CM_IRQ and remains latched until the monitor processor module services the interrupt, and issues a clear signal. Once the latch is cleared, CM_IRQ goes disabled.

EFFECTIVITY _____

ALL

34-42-37

Page 39
10 Oct 2007

Honeywell

COMPONENT MAINTENANCE MANUAL

Part No. 066-50007

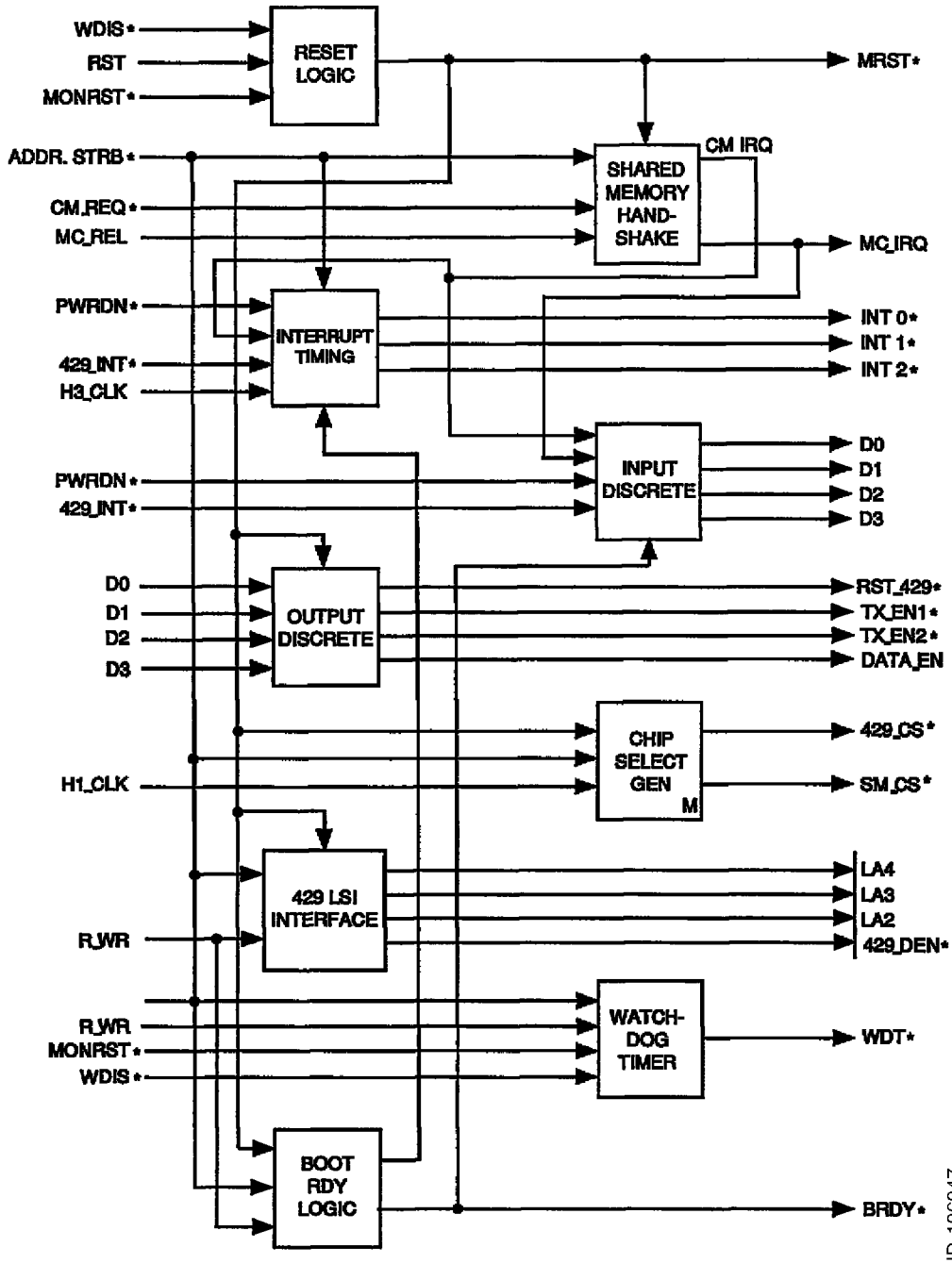

Figure 8. (Sheet 1 of 1) U11 Functional Block Diagram (GRAPHIC 34-42-37-99B-809-A01)

EFFECTIVITY
ALL

34-42-37

Page 40
10 Oct 2007

Honeywell

COMPONENT MAINTENANCE MANUAL

Part No. 066-50007

(3) 429 Interface

- (a) The Monitor Processor CCA listens to the 429 transmitters on the main processor module. There are two modes, interrupt and continuous.
 - 1 In the interrupt mode if there is something wrong with either module, the monitor processor module automatically shuts off the 429 transmitters on the main processor module.
 - 2 In the continuous mode, the monitor processor module will not shut off the transmitters.
- (b) The signals that are used to shut off the transmitters are:
 - XMON_BUS_DIS_#1 (J6018-74)
 - XMON_BUS_DIS_#2 (J6018-75)
 - XMON_DATA_ENABLE (J6018-76).
- (c) In a default, as long as there is power to the monitor processor module the transmitters are turned off.
- (d) Device U10 is the ARINC 429 LSI and U12 is the ARINC 429 receiver. Receiver U12 receives the transmitter signals from the main processor module. LSI U10 processes the signals. The programmable logic device does the ARINC 429 interrupt timing U11.
- (e) The transistor Q1 supplies the drive to the monitor data enable discrete and to a default position, which turns the transmitters on the main processor module off.

(4) DSP Serial Interface

- (a) The DSP serial interface is connector J6045, which is two DSPs that communicate with each other directly. One is on the Monitor Processor CCA, which is U3. The other DSP is on the main processor CCA.
- (b) The monitor processor module DSP U3 is be reset by:
 - External reset from the main processor module
 - 5 volt supply dipping below threshold value
 - Watchdog timer reset.
- (c) After monitor DSP U3 is reset by either the 5-volt monitor or the watchdog timer, it stays reset until main processor issues a reset. When WDIS test point is strapped to ground, both the 5-volt monitor and the watchdog timer are disabled. In addition, BOOT RDY is written to in order to enable the watchdog function. Until then, watchdog cannot cause reset.
- (d) Device U4 is the supervisor and reset circuit, which has:
 - Watchdog timer functions
 - Reset function
 - Over-voltage monitor function.
- (e) The output reset signal goes to the programmable logic device U11.

EFFECTIVITY _____

ALL

34-42-37

Page 41
10 Oct 2007

Honeywell

COMPONENT MAINTENANCE MANUAL

Part No. 066-50007

- (f) Device U7 is an address decoder, which generates memory chip select. Device U13A generates the ready signal for the DSP U3. Connector J6045 is an emulator connection used for development.

E. Power Supply Assembly (Subtask 34-42-37-870-013-A01)

(1) General

- (a) The power supply assembly is a self-contained, high-efficiency, switching power supply that converts the +28 V dc aircraft power into the needed dc operational voltages. Three voltages are supplied:
- + 5 V dc
 - +12 V dc
 - -12 V dc.
- (b) The power supply assembly contains two modules:
- Power supply input module
 - Power supply output module.
- (c) See Figure 2008 (GRAPHIC 34-42-37-99B-818-A01) for a schematic diagram of the power supply input module. See Figure 2009 (GRAPHIC 34-42-37-99B-819-A01) for a schematic diagram of the power supply output module.

(2) Power Supply Input Module

- (a) See Figure 2008 (GRAPHIC 34-42-37-99B-818-A01) for a schematic diagram of the power supply input module. The aircraft + 28 V dc power is applied to the input module through connector J3108, pins 1 thru 4. The aircraft + 28 V dc voltage is applied to hot swap controller U1. Hot swap controller U1 is an 8-pin hot swap controller that allows a board to be safely inserted and removed from a live unit. The hot swap controller uses N-channel pass transistor Q1 so that the board supply voltage can be ramped up at a programmable rate.
- (b) The voltage on hot swap controller U1-1 is used to supply under-voltage lockout. When the voltage ON pin, U1-1, is pulled below 1.233V an under-voltage condition is detected. The GATE on U1-6 is pulled low to turn the transistor Q1 off. When the ON pin, U1-1, rises above 1.313V low-to-high threshold voltage, the transistor Q1 is turned on again.
- (c) The voltage on hot swap controller U1-2 (FB) is the power good comparator input. It monitors the output voltage with an external resistive divider R3 and R4. When the voltage on the FB pin is lower than the high-to-low threshold of 1.233V, the PWRGD pin U1-3 is pulled low. This pin is not used on this module.
- (d) The voltage on hot swap controller pin U1-5 is the timing input. External timing capacitors, C3, C6, and C13 at this pin programs the maximum time U1 is allowed to remain in current limit. When the part goes into current limit, a 77-microamp pull-up current source starts to charge the timing capacitors. When the voltage on the TIMER pin reaches 1.233V, the GATE pin (U1-6) is pulled low. The pull-up current is turned off and a 3 microamp pull-down current discharges the capacitors. When the TIMER pin falls below 0.5 Volts, the GATE pin either turns

EFFECTIVITY _____

ALL

34-42-37

Page 42
10 Oct 2007

Honeywell

COMPONENT MAINTENANCE MANUAL

Part No. 066-50007

on automatically or turns on once the ON pin is pulsed low to reset the internal fault latch. If the ON pin is not cycled low, the GATE pin remains latched off.

- (e) The voltage on hot swap controller pin U1-6 is the high side gate drive for the N-channel transistor Q1. An internal charge pump guarantees at least 10 volts of gate drive for supply voltages above 20 volts and 4.5 volts gate drive for supply voltages between 10.8 and 20 volts. The rising slope of the voltage at the GATE U1-6 is set by an external capacitor C5 connected from the GATE pin to GND and an internal 10A pull-up current source from the charge pump output.
 - (f) When the current limit is reached, the GATE pin voltage adjusts to maintain a constant voltage across the sense resistor while the timer capacitor starts to charge. If the TIMER pin voltage exceeds 1.233V, the GATE pin is pulled low. The GATE pin is pulled to GND when the ON pin is pulled low, the VCC supply voltage drops below the 8.3V under-voltage lockout threshold or the TIMER pin rises above 1.233V.
 - (g) The voltage on hot swap controller pin U1-7 is the current limit sense. A sense resistor R8 is placed in the supply path between VCC and SENSE. The current limit circuit regulates the voltage across the sense resistor to 47 millivolts if the voltage on U1-2 is 0.5V or higher. If the voltage on U1-2 drops below 0.5V, the voltage across the sense resistor decreases linearly and stops at 12 millivolts when U1-2 is 0V. To defeat current limit, short the SENSE pin to the VCC pin.
 - (h) The 28 V dc output of the power supply input module is applied to the power supply output module through connector J3302.
- (3) Power Supply Output Module
- (a) See Figure 2009 (GRAPHIC 34-42-37-99B-819-A01) for a schematic diagram of the power supply output module. The power supply output module converts the 28 V dc from the hot swap controller into the three power supply voltages, +5 V dc, +12 V dc, and -12 V dc.
 - (b) Each of the power supplies in the power supply output module use a PWM controller and two switching transistors to develop each voltage. Table 7 lists the PWMs and the transistors.

Table 7. Power Supply Components

Power Supply	PWM	Transistors
+5 V dc	U2	Q3 and Q4
+12 V dc	U1	Q1 and Q2
-12 V dc	U3	Q5 and Q6

- (c) All three of the supplies operate the same and only the +5 V dc supply is described in this section.
- (d) The 28 V dc from the hot swap controller is applied to PWM U2-15. The PWM U2 is a high-voltage, wide input (10 to 55 Volts) synchronous, step-down converter. Table 8 lists the pins of the PWM and the function of each pin.

EFFECTIVITY _____

ALL

34-42-37

Page 43
10 Oct 2007

Honeywell

COMPONENT MAINTENANCE MANUAL

Part No. 066-50007

Table 8. PWM Pin Functions

PWM Pin	Function
U2-15 (VIN)	+28 V dc input voltage
U2-2 (RT)	Sets the internal oscillator ramp charge current and switching frequency with resistor R23 and capacitor C36.
U2-1 (KFF)	Sets the output voltage and the slope of the voltage ramp with resistor R25.
U2-6 (SD/SS)	Soft start programming pin
U2-4 (SYNC)	Synchronization input
U2-7 (VFB)	Inverted input to the error amplifier
U2-12 (SW)	Used for over-current sense
U2-16 (ILIM)	Current limit pin, used to set the over-current threshold.
U2-8 (COMP)	Output of the error amplifier, input to the PWM comparator.
U2-10 (LDRV)	Gate drive for the N-channel synchronous rectifier Q4. This pin switches from MOSFET Q4 on to ground, MOSFET Q4 off
U2-14 (HDRV)	Floating drive for the high-side P-channel MOSFET Q5. This pin switches from MOSFET Q3 off to MOSFET Q3 on

- (e) The 28 V dc is converted to an ac voltage by the switching action of transistors Q3 and Q4. Transistor Q3 is a P-channel MOSFET device. It is turned on and off by the voltage on U2-14 (HDRV). Transistor Q4 is an N-channel MOSFET device. It is turned on and off by the voltage on U2-10 (LDRV).
- (f) The ac voltage generated by transistors Q3 and Q4 is rectified by diodes D14 and D15. The rectified dc voltage is filtered by L2 and capacitors C30 thru C35.

F. Rear Interconnect Module (Subtask 34-42-37-870-014-A01)

- (1) See Figure 2006 (GRAPHIC 34-42-37-99B-816-A01) for a schematic diagram of the rear interconnect module. The rear interconnect module supplies the antenna connections, power, and signal/data paths between the rear connector of the unit and the ALA-52B internal circuits.
- (2) The power supply input lines are straight through connections between rear connector J1-BP-9 to pins 1 thru 4 of connector J14.
- (3) The I/O signal lines are grouped on the schematic diagram into four categories:
 - ARINC 429 inputs
 - ARINC 429 outputs

EFFECTIVITY _____

ALL

34-42-37

Page 44
10 Oct 2007

Honeywell

COMPONENT MAINTENANCE MANUAL

Part No. 066-50007

- Discrete inputs
 - Discrete outputs.
- (4) Wirewound resistors, 100 ohm, 1 watt, along with TVS devices provide lightning protection for all ARINC inputs.
 - (5) All ARINC outputs have TVS devices to provide lightning protection. The lightning current limiting is provided by the connected LRUs.

G. Front Panel Module (Subtask 34-42-37-870-015-A01)

- (1) See Figure 2005 (GRAPHIC 34-42-37-99B-815-A01) for a schematic diagram of the LED CCA. The LED CCA is an interface to an operator by the use of three LEDs and a test switch.
- (2) The LEDs D1, D2, and D3 display either red or green light when turned on. The LED D1 shows the radio altimeter status. The LED D2 shows the receive antenna status and D3 shows the transmit antenna status. The test switch S1 is used to test the entire unit operation.
- (3) A front panel connector is used for a handheld remote device or to program the unit.

EFFECTIVITY _____

ALL

34-42-37

Page 45
10 Oct 2007

Honeywell

COMPONENT MAINTENANCE MANUAL

Part No. 066-50007

Blank Page

EFFECTIVITY

ALL

34-42-37

Page 46
10 Oct 2007

Honeywell

COMPONENT MAINTENANCE MANUAL

Part No. 066-50007

TESTING AND FAULT ISOLATION

1. **Planning Data** (TASK 34-42-37-99C-801-A01)

A. **Reason for the Job** (Subtask 34-42-37-99C-001-A01)

- (1) Use the test procedures in this section to do tests and fault isolate the ALA-52B.
- (2) The function of the test procedures is to find if there is a failure in the operation of the ALA-52B.

B. **Job Setup Data** (Subtask 34-42-37-99C-002-A01)

- (1) You can use equivalent alternatives for the special tools, fixtures, equipment, and consumable materials. The user must find equivalent alternatives.
- (2) Refer to Table 1001 for the specified special tools, fixtures, and equipment in this section. If this section refers to online data, refer to that data for the specified special tools, fixtures, and equipment.

Table 1001. Special Tools, Fixtures, and Equipment

Number	Name
11730A	RF power sensor cable (CAGE 1MY97)
300-90273-0504	memory card interface module (CAGE 97896)
704-2899-001	ALA-52B ATP cable (CAGE 97896)
8074177-0001	ISP programming cable (CAGE 97896)
951-0409-00X	COMNAV RTS (CAGE 97896)
951-0423-001	front panel interface adapter (CAGE 97896)
998-3804-5XX	ATP software (CAGE 97896)
998-3853-503 (or later)	Delta software (CAGE 97896)
	Microsoft Windows 2000 or above (optional source)
ALT 52A	Altitude simulator (CAGE 97896)
CA1267-60	RA power meter cable (CAGE 1UKX3)
CA1267-60	RA spectrum analyzer cable (CAGE 1UKX3)
E4418B	RF power meter (CAGE 1MY97)
E9304A	RF power sensor (CAGE 1MY97)
FSEB30 or FSIQ7	Spectrum analyzer (CAGE 82199)
Version 16.x	LSC isp VM system software (CAGE 66675)

EFFECTIVITY _____

ALL

34-42-37

Page 1001
10 Oct 2007

Honeywell

COMPONENT MAINTENANCE MANUAL

Part No. 066-50007

WARNING: BEFORE YOU USE A MATERIAL, REFER TO THE MANUFACTURERS' MATERIAL SAFETY DATA SHEETS. SOME MATERIALS CAN BE DANGEROUS.

CAUTION: DO NOT USE MATERIALS THAT ARE NOT EQUIVALENT TO HONEYWELL SPECIFIED MATERIALS. MATERIALS THAT ARE NOT EQUIVALENT CAN CAUSE DAMAGE TO THE EQUIPMENT AND CAN MAKE THE WARRANTY NOT APPLICABLE.

- (3) Refer to Table 1002 for the specified consumable materials in this section. If this section refers to online data, refer to that data for the specified consumable materials.

Table 1002. Consumable Materials

Number	Name
Not applicable	Not applicable

2. **Procedure** (TASK 34-42-37-810-801-A01)

A. **Job Setup** (Subtask 34-42-37-810-001-A01)

WARNING: BEFORE YOU USE A MATERIAL, REFER TO THE MANUFACTURERS' MATERIAL SAFETY DATA SHEETS. SOME MATERIALS CAN BE DANGEROUS.

CAUTION: DO NOT USE MATERIALS THAT ARE NOT EQUIVALENT TO HONEYWELL SPECIFIED MATERIALS. MATERIALS THAT ARE NOT EQUIVALENT CAN CAUSE DAMAGE TO THE EQUIPMENT AND CAN MAKE THE WARRANTY NOT APPLICABLE.

CAUTION: THE ALA-52B CONTAINS ESDS ITEMS. USE INDUSTRY APPROVED PRECAUTIONS.

- (1) Obey the precautions.
- (2) Refer to Table 1003 for a list of test procedures that are included in this section.

Table 1003. Test Procedures

Procedure Part Number	Revision	Used On Part Number	Reference
076-1132-001	B	066-50007-1111	Figure 1001 (GRAPHIC 34-42-37-99B-810-A01)

B. **Testing of the ALA-52B** (Subtask 34-42-37-810-002-A01)

- (1) Use Figure 1001 (GRAPHIC 34-42-37-99B-810-A01) to do a test of the ALA-52B, Part No. 066-50007-1111.

C. **Job Close-up** (Subtask 34-42-37-810-003-A01)

- (1) Not applicable.

EFFECTIVITY _____
ALL

34-42-37

Page 1002
10 Oct 2007

Honeywell

COMPONENT MAINTENANCE MANUAL

Part No. 066-50007

Table of Contents

- 1.0 INTRODUCTION**
 - 1.1 PURPOSE
 - 1.2 IDENTIFICATION AND DESCRIPTION
 - 1.3 SCOPE
 - 1.4 GENERAL NOTES
 - 1.5 SPECIAL NOTES
- 2.0 DELETED**
- 3.0 EQUIPMENT AND SOFTWARE REQUIRED**
 - 3.1 REQUIRED HARDWARE
 - 3.2 FACILITIES
 - 3.3 SYSTEM SOFTWARE
- 4.0 ENVIRONMENT**
- 5.0 QUALITY ASSURANCE PROVISIONS**
 - 5.1 CALIBRATION
 - 5.2 INSPECTION
 - 5.3 ACCEPTANCE
- 6.0 PREPARING FOR TEST**
 - 6.1 TEST PLATFORM SOFTWARE INSTALLATION
 - 6.2 TEST PLATFORM SETUP
 - 6.3 PREPARING COMNAV RTS GSE FOR UUT TEST
- 7.0 UNIT SOFTWARE LOADING**
 - 7.1 PCMCIA PROGRAMMING
 - 7.2 LATTICE PART PROGRAMMING
 - 7.3 CONFIGURATION MEMORY INITIALIZATION
- 8.0 UNIT ALIGNMENT**
- 9.0 ACCEPTANCE TEST PROCEDURE**
- APPENDIX A ALA-52B TEST SETUP**

Figure 1001. (Sheet 1 of 12) ALA-52B Test Procedure (GRAPHIC 34-42-37-99B-810-A01)

EFFECTIVITY _____

ALL

34-42-37

Page 1003
10 Oct 2007

Honeywell

COMPONENT MAINTENANCE MANUAL

Part No. 066-50007

1.0 INTRODUCTION

1.1 Purpose

This document defines the Acceptance Test Procedure to certify the functionality of ALA-52B, Honeywell Part Number 066-50007. All tests defined herein have pass/fail criteria, and the results of the tests are recorded in the automatic test report generated each time the Acceptance Test sequence is performed. A failure of any test constitutes failure of the LRU acceptance. This test procedure also details the setup and usage of the CommNav RTS platform and CommNav RTS test software.

1.2 Identification and Description

The Unit-Under-Test (UUT) defined is ALA-52B, Honeywell Part Number 066-50007. This test procedure defines all automatic test procedures. Microsoft® Windows® application test software, installed in 951-0409-00x test systems with proper configuration for the UUT, is used to perform the required tests. Details for the setup and usage of the 951-0409-00x and applicable RTS test software are described in this test procedure.

1.3 Scope

The software installed on the 951-0409-00x controls all of the tests automatically. The testing is limited to those requirements defined in the Test Specification (TS), refer to paragraph 2.0.

1.4 General Notes

- a. Interpret drawing per ASME Y14.100-2000.
- b. This document was produced using Microsoft® Word 2003. All Figures were created using the drawing program that is included with Word.
- c. Computer screen images in the document are for pictorial representation only and represent a visual recognition pattern for the items shown. Textual content in these figures is not required to meet legibility requirements when reproduced. These figures are intended to show general concepts and may not represent the actual screen image.

1.5 Special Notes

- a. Ensure that each item of test equipment in use is within its designated calibration period prior to commencement of this test procedure as per the local-shop calibration laboratory operating procedure.
- b. Ensure that all software installed is a current revision.
- c. Trademarks
 - Microsoft is a registered trademark of *Microsoft Corporation*.
 - MS-DOS is a registered trademark of *Microsoft Corporation*.
 - Windows is a trademark of *Microsoft Corporation*.
 - Word for Windows is a trademark of *Microsoft Corporation*
- d. Acronyms and Abbreviations pertaining to this document are:

Figure 1001. (Sheet 2 of 12) ALA-52B Test Procedure (GRAPHIC 34-42-37-99B-810-A01)

EFFECTIVITY _____

ALL

34-42-37

Page 1004
10 Oct 2007

Honeywell

COMPONENT MAINTENANCE MANUAL

Part No. 066-50007

ARINC	Aeronautical Radio Incorporated
ATP	Acceptance Test Procedure
CommNav	Communication and Navigation
DLL	Dynamic Link Library
GSE	Ground Support Equipment
ITS	Integrated Test System
LRU	Line Replaceable Unit
RTE	Redmond Test Engineering
RTS	Redmond Test System
TRD	Test Requirements Document
RtsMuee	Redmond Test System Multi-Unit Execution Engine
UUT	Unit Under Test

Table 1

2.0 DELETED

Table 2 Deleted

3.0 EQUIPMENT AND SOFTWARE REQUIRED

The following equipment and software or its equivalent is authorized for use with this procedure.

Figure 1001. (Sheet 3 of 12) ALA-52B Test Procedure (GRAPHIC 34-42-37-99B-810-A01)

EFFECTIVITY

ALL

34-42-37

Page 1005
10 Oct 2007

Honeywell

COMPONENT MAINTENANCE MANUAL

Part No. 066-50007

3.1 Required Hardware

Equipment Description	Model or Part Number	Manufacturer(s)
COMNAV RTS	951-0409-00X	Honeywell
ALA-52B ATP Cable	704-2899-001	Honeywell
Memory Card Interface Module	300-90273-0504	Honeywell
Front Panel Interface Adapter	951-0423-001	Honeywell
RF Power Meter	E4418B	Agilent
AGILENT RF POWER SENSOR	E9304A	Agilent
RF POWER SENSOR CABLE	11730A	Agilent
SPECTRUM ANALYZER	FSEB30 or FSIQ7	Rohde & Schwarz
CABLE, RA SPECTRUM ANALYZER	CA1267-60	FEDERAL CUSTOM CABLE
CABLE, RA Power Meter	CA1267-60	FEDERAL CUSTOM CABLE
Altitude Simulator	ALT 52A	Bendix
ISP Programming Cable	8074177-0001	Honeywell
Parallel Cable DB25 M/M		Any

Table 3

3.2 Facilities

115 VAC, 60 Hz, 20 Amp

3.3 System Software

The following software should be installed on the Test Platform control PC:

- Microsoft Windows 2000 or above
- Driver software.
- DELTA software PN 998-3853-503 or later.
- ATP software 998-3804-5xx
- LSC ispVM System Software Version 16.x.

4.0 ENVIRONMENT

Testing shall be performed under the following environmental conditions.

Ambient Temperature of 60 to 85 F.

Relative Humidity 20% to 60%

5.0 QUALITY ASSURANCE PROVISIONS

5.1 Calibration

Ensure that the 951-0409-00X Platform in use is within its designated calibration period prior to commencement of this acceptance Test.

5.2 Inspection

Examine the inspection records compiled during manufacture of the unit, for both completeness and acceptability

Figure 1001. (Sheet 4 of 12) ALA-52B Test Procedure (GRAPHIC 34-42-37-99B-810-A01)

EFFECTIVITY

ALL

34-42-37

Page 1006
10 Oct 2007

Honeywell

COMPONENT MAINTENANCE MANUAL

Part No. 066-50007

5.3 Acceptance

At the completion of the ALA-52B ATP sequence, a test log will be created and stored on the system hard drive in folder C:\Test Report\ALA\Formal\ALA-52B ATP. The file name format will be 'nnnnnYYYYMMDDHHMMSS.txt' where 'nnnnn' is the LRU serial number. Example file name: 0378720060925012159.txt Additional test logs will be stored in C:\Test Report\ALA\Formal\sequence name or C:\Test Report\ALA\User\sequence name depending on whether the sequence is a formal or user defined sequence. The formal sequences are denoted by a lock symbol indicating that they cannot be modified.

6.0 PREPARING FOR TEST

6.1 Test Platform Software Installation

NOTE: The following is applicable ONLY on an initial setup, one-time basis. If this is a new installation, do it now. If not, verify current revisions in section 3.3 of this procedure and move to section 6.2

- a. Install Microsoft Windows 2000 or above as described in the Microsoft Windows documentation.
- b. Install the Drivers setup disk for DELTA system
- c. Install the DELTA software PN 998-3853-503 or later.
- d. If no ATP icon on desktop installs ATP software 998-3804-5xx

6.2 Test Platform Setup

- a. Ensure that the LRU cable is connected to the Test Platform front panel. Refer Appendix-A and Appendix B for Tester Setup. Install the UUT into the station by inserting the UUT into the appropriate LRU Tray
- b. Ensure that the UUT connector is firmly seated and locked.

6.3 Preparing CommNav RTS GSE for UUT Test

Verify the following equipment is turned on:

- a. Test Platform Main Power
- b. PXI Chassis Power
- c. DC Power Supply(s) Power
- d. AC Power Supply(s) Power
- e. PC Power. (Note: PC power MUST be applied AFTER the PXI Chassis power)

If a printer is used, verify the printer is connected to the PC.

NOTE: The printer is optional. The ALA-52B ATP will execute if the printer is present or not, but to produce a hard copy of the ATP results, a printer is needed.

Figure 1001. (Sheet 5 of 12) ALA-52B Test Procedure (GRAPHIC 34-42-37-99B-810-A01)

EFFECTIVITY _____

ALL

34-42-37

Page 1007
10 Oct 2007

Honeywell

COMPONENT MAINTENANCE MANUAL

Part No. 066-50007

7.0 Unit Software Loading

7.1 PCMCIA Programming

NOTE: Check the parts list of the Monitor Processor to find the latest version the diskette XU11.

NOTE: Check the parts list of the ALA-52B to find the Flash Card which contains the latest version of flight resident software.

1. Assure that the jumpers on J11 of the Main Processor are in positions 1-2 and 3-4 (not positions 5-6 and 7-8).
2. Insert the Flight Resident Software flasheard into the Memory Card Interface Module. Install the Memory Card Interface Module onto J7 of the Main Processor Module.
3. Use the Parallel Cable to connect the Front Panel Interface Adapter to the LRU front panel. Connect P4 of the ATP cable to the Front Panel Interface Adapter.
4. Double click the shortcut "CommNav RTS Test Executive" either from the desktop or from Start->Programs->RTS->CommNav RTS Test Executive to launch the CommNav RTS Software. Once the Test Executive (RtsMuee) window opens, the UUT options are shown (see Figure 1).

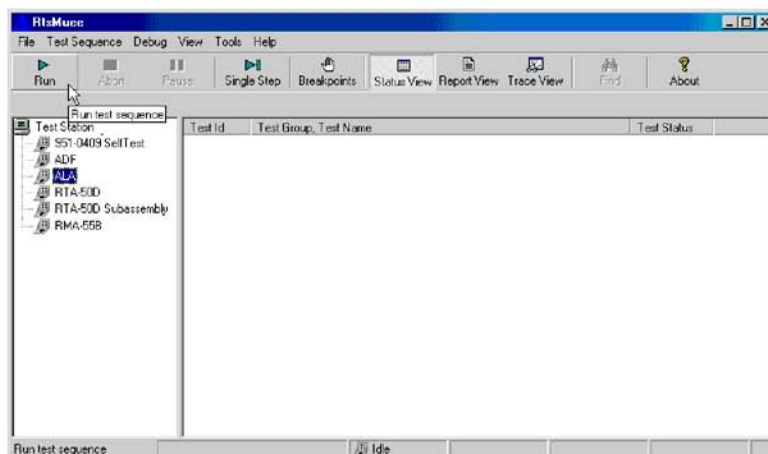

Figure 1. RTSMuee Start-up Menu

5. Click on the **Run** button after highlighting the appropriate UUT under **Test Station** in the navigation window.
6. The Sequence Selection dialog will open (see Figure 2). Select the POWER-ON-OFF sequence.

Figure 1001. (Sheet 6 of 12) ALA-52B Test Procedure (GRAPHIC 34-42-37-99B-810-A01)

EFFECTIVITY
ALL

34-42-37

Page 1008
10 Oct 2007

Honeywell

COMPONENT MAINTENANCE MANUAL

Part No. 066-50007

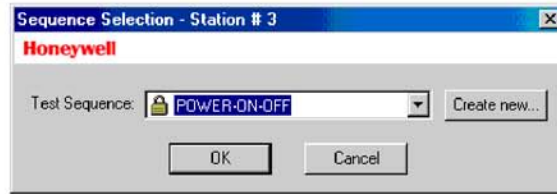

Figure 2. Sequence selection

- 7 When the ATP Configuration window appears enter the Operator Name, the UUT Serial Number, and select the part number of the UUT. Select **Continue**.

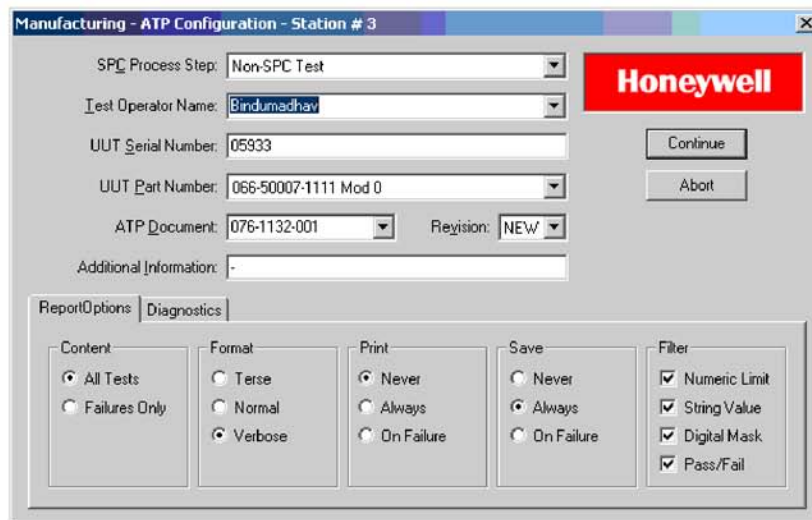

Figure 3. ATP Configuration window

- 8 After the ATE applies power to the LRU the display on the Front Panel Interface Adapter should show instruction "Press Start". Press either button to load the boot flash program.
- 9 When the "Boot Load" is complete disable LRU power by selecting **Yes** in the dialog shown below (see Figure 4).
- 10 Move the jumpers from the shop mode to the normal mode on the Main Processor board (from positions 1-2 and 3-4 to positions 5-6 and 7-8 on J11). Enable LRU power by again selecting **Yes** in the dialog (see Figure 4).
- 11 Follow the instructions on the display of the Front Panel Interface Adapter. The LRU software load will take several minutes. Remove the flash card when prompted to do so but leave the power on.

Figure 1001. (Sheet 7 of 12) ALA-52B Test Procedure (GRAPHIC 34-42-37-99B-810-A01)

EFFECTIVITY

ALL

34-42-37

Page 1009
10 Oct 2007

Honeywell

COMPONENT MAINTENANCE MANUAL

Part No. 066-50007

NOTE: After card removal the LRU will automatically start verification of the loaded flash memory which will also require several minutes.

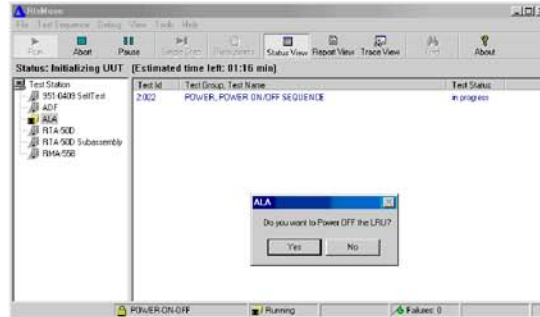

Figure 4. Toggle LRU Power

7.2 Lattice Part Programming

NOTE: Check the parts list of the ALA-52B to identify the Monitor Cable W8.

- 1 Disable LRU power by selecting **Yes** in the power toggle dialog (see Figure 4).
- 2 Remove the Memory Card Interface Module from the Main Processor Module.
- 3 Connect the Monitor Cable W8 per the ALA52B drawing.
- 4 Connect the ISP Programming Cable to the Monitor Processor ISP programming connector J43.

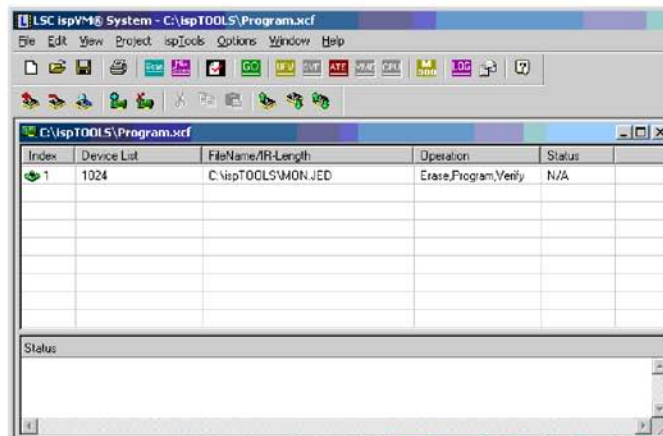

Figure 5. Lattice Programming

Figure 1001. (Sheet 8 of 12) ALA-52B Test Procedure (GRAPHIC 34-42-37-99B-810-A01)

EFFECTIVITY
ALL

34-42-37

Page 1010
10 Oct 2007

Honeywell

COMPONENT MAINTENANCE MANUAL

Part No. 066-50007

- 5 Enable LRU power by selecting **Yes** in the power toggle dialog (see Figure 4).
- 6 Double click the shortcut "ispVMSystem" either from the desktop or from Start->Programs->Lattice Semiconductor-> ispVMSystem to launch the Lattice Programming Software.
- 7 The ISPVM system window should display (see Figure 5). It may be necessary to select "C:\ISPTools\Program.xcf" from the File menu to obtain the setup shown.
- 8 Select the **GO** icon to begin programming. Verify the status is "PASS" on programming completion.
- 9 Select "C:\ISPTools\Checksum.xcf" from the File menu. The "Operation" shown in the ISPVM system window should change to "Calculate Checksum".
- 10 Select the **GO** icon. Verify that the checksum agrees with the LRU shop order.
- 11 Disable LRU power and exit the power toggle program by selecting **No** in the power toggle dialog (see Figure 4).
- 12 Disconnect the ISP Programming Cable from the Monitor Processor.

7.3 Configuration Memory Initialization

-  LRU HW CONFIGURATION INTTIALIZE - run this sequence on newly assembled units after software loading.

- 1 Click on the **Run** button after highlighting the appropriate UUT under **Test Station** in the navigation window (see Figure 1).
- 2 The Sequence Selection dialog will open. Select the LRU HW CONFIGURATION INTTIALIZE sequence (see Figure 6).

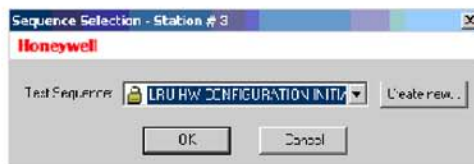

Figure 6. Configuration Memory Initialization Sequence

- 3 When the ATP Configuration window appears (see Figure 3). Verify that the LRU information is correct.

Note. The initialization operation will write the serial number and part number into LRU memory along with the default settings.

- 4 Select **Continue**. Verify that a pass status is achieved.

Figure 1001. (Sheet 9 of 12) ALA-52B Test Procedure (GRAPHIC 34-42-37-99B-810-A01)

EFFECTIVITY _____

ALL

34-42-37

Page 1011
10 Oct 2007

Honeywell

COMPONENT MAINTENANCE MANUAL

Part No. 066-50007

8.0 Unit Alignment

-  ALA-52B ALIGNMENT - run this sequence prior to ATP or to correct an ATP failure.
- 1 Click on the **Run** button after highlighting the appropriate UUT under **Test Station** in the navigation window (see Figure 1).
- 2 The Sequence Selection dialog will open. Select the ALA-52B ALIGNMENT sequence (see Figure 7).

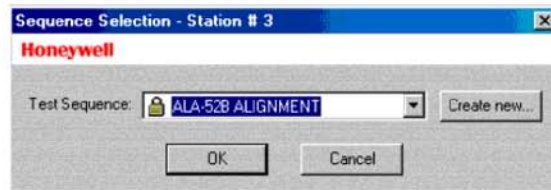



Figure 7. ALA-52B Alignment Sequence

- 3 When the ATP Configuration window appears select **Continue**. Verify that a pass status is achieved for all four alignment steps.

Note. In the first alignment step the operator will be prompted to enter the two digit AGC1 value, which is on a label fixed to the RF assembly CCA near the front of the LRU.

9.0 Acceptance Test Procedure

-  ALA-52B ATP - final acceptance test prior to shipping
- 1 Click on the **Run** button after highlighting the appropriate UUT under **Test Station** in the navigation window (see Figure 1).
- 2 The Sequence Selection dialog will open. Select the ALA-52B ATP sequence (see Figure 8).

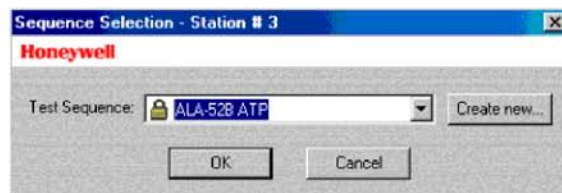

Figure 8. ALA-52B ATP Sequence

NOTE: Figure 3 shows the preferred ATP report option settings in the ATP Configuration window.

- 3 When the ATP Configuration window appears (see Figure 3) verify that the LRU information is correct. Select **Continue** to start the test. The status icon at the bottom of Test Executive window will indicate that the executive is "Running".

Figure 1001. (Sheet 10 of 12) ALA-52B Test Procedure (GRAPHIC 34-42-37-99B-810-A01)

EFFECTIVITY
ALL

34-42-37

Page 1012
10 Oct 2007

Honeywell

COMPONENT MAINTENANCE MANUAL

Part No. 066-50007

NOTE: The executive performs equipment self-checks before beginning to test the LRU. This can take several minutes.

- 4 After the LRU tests begin the operator will be prompted to press the LRU self test button and then to answer some questions. After this the test can run unattended. On test completion the status icon at the bottom of Test Executive window will indicate that the executive is "Idle".
- 5 On test completion verify that a pass status is indicated on the test report.

NOTE: Consult the appropriate routing documentation to determine which test step to execute.

Figure 1001. (Sheet 11 of 12) ALA-52B Test Procedure (GRAPHIC 34-42-37-99B-810-A01)

EFFECTIVITY _____

ALL

34-42-37

Page 1013
10 Oct 2007

Honeywell

COMPONENT MAINTENANCE MANUAL

Part No. 066-50007

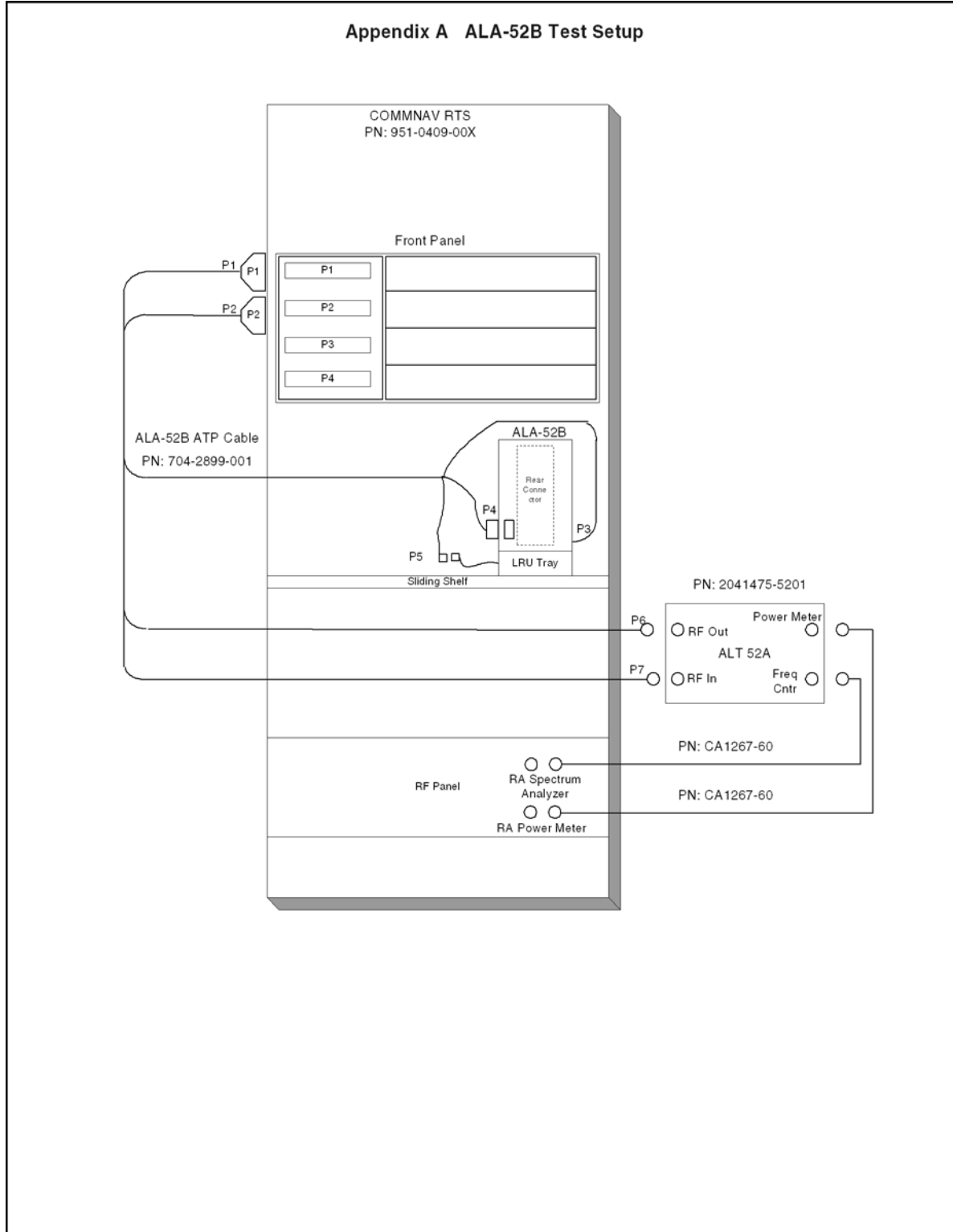

Figure 1001. (Sheet 12 of 12) ALA-52B Test Procedure (GRAPHIC 34-42-37-99B-810-A01)

EFFECTIVITY _____
ALL

34-42-37

Page 1014
10 Oct 2007