Operator's Manual

Hyfrecator[®]2000

ELECTROSURGICAL UNIT

Serving the Physician Since 1937



#11

© 1998 CONMED Corporation

310 Broad Street
Utica, New York 13501 U.S.A.

For Technical Services or Return Authorization Phone:
303-699-7600 / 1-800-552-0138 Extension 5274
Fax 303-699-9854

For Customer Services or to order parts phone:
1-800-448-6506 / 315-797-8375 / Fax 315-735-6235
or contact your CONMED Representative.

European Authorized Representative
MDSS GmbH
Burckhardtstr 1
D - 30163 Hannover
Germany

The revision level of this manual is specified by the
highest revision letter found on either the inside front
cover or enclosed errata pages (if any).

Manual Number 7-900-OM-ENG Rev. -

Unit Serial Number _____

MANUAL ERRATA	MODEL: Hyfrecator 2000	MANUAL P/N: 7-900-OM-ENG
REVISION LEVEL: C	CO NO.: 10484	DATE: 08/10/2007

EFFECTIVITY: All units

DESCRIPTION: Make the following changes to the Hyfrecator 2000 Operator Manual (English):
Changed corporate address shown on inside front cover.

- **WAS:** ...310 Broad St.
 Utica, New York 13501...
- **NOW:** ...**525 French Road**
 Utica, New York **13502**...

Changed European sales address shown on inside front cover.

- **WAS:** ...MDSS GmbH
 Burckhardstr 1
 D – 30163 Hannover...
- **NOW:** ...MDSS GmbH
 Schiffgraben 41
 D – **30175** Hannover...

The revision level of this manual is specified by the highest revision letter found on either the inside front cover or enclosed ERRATA pages.

MANUAL ERRATA	MODEL: Hyfrecator 2000	MANUAL P/N: 7-900-OM-ENG
REVISION LEVEL: B	ECN NO.: 8431	DATE: 7/21/04

EFFECTIVITY: All units.

NOTE: This errata supercedes errata revision A, previously released.

DESCRIPTION:

Pages 17 - 18, Section 9 - Maintenance; subsection "Sterilization of Accessories" is revised as follows:

Delete all existing text in this section and replace with:

"For sterilization of Hyfrecator accessories, refer to the Instructions for Use insert included with the accessory.

NOTE: It is not advisable to cold sterilize surgical electrodes due to potential corrosion.

NOTE: Non-sterile Electrolase® Tips are not validated for sterilization. Do not attempt to sterilize these tips.

NOTE: Do not sterilize the footswitch (Cat. No. 7-900-4).

Page 19, Section 10 - Optional Accessories, Item 6 is revised as follows:

Change "(Cat. No. 7-800-6)" to "(Cat. No. 7-900-6)".

Page 19, Section 11 - Warranty is revised as follows:

Change "A ninety (90) day warranty is provided for standard and optional accessories." to "A ninety (90) day warranty is provided for standard and optional accessories except as defined in the Instructions for Use included with the accessory."

Delete "The ninety (90) day warranty includes the power up/down switching handle and cord."

The revision level of this manual is specified by the highest revision letter found on either the inside front cover or enclosed ERRATA pages.

Hyfrecator2000

Table of Contents

Section	Title	Page
-	Introduction	1
1	Inspection	1
2	Safety Precautions and Warnings	1
3	Operating Controls and Indicators	4
4	Operation of Your Instrument	7
5	Suggestions for First-Time Operation	7
6	Terminology for Systems Configuration	8
7	Terminology for Procedural Configuration	10
8	Applications	12
9	Maintenance	17
10	Optional Accessories	18
11	Warranty	19
12	In Case of Difficulty	20
13	Repair and Return Policy	20
14	Environmental Protection	20
15	Specifications	21
16	Symbols	22
17	Index of Reference Material	23
18	Performance Graphs	23

Figure	Title	Page
1	Front, Side and Bottom Panel Controls	4
2	Back Panel Controls	6
3	Monoterminal Without a Dispersive Plate Configuration	8
4	Monoterminal with Dispersive Plate Configuration	9
5	Bipolar Configuration	9
6	Desiccation	10
7	Epilation	10
8	Fulguration	11
9	Monoterminal Coagulation	11
10	Bipolar Coagulation	11
11	Peak Voltage vs. Setting	23
12	Power Out vs. Display	23
13	Load Regulation Curves	24



Introduction

Congratulations on your purchase of the CONMED HYFREATOR® 2000 . The HYFREATOR® was introduced in 1937 and has become the world leader in office-based electrosurgery. With the latest model, the HYFREATOR® 2000, CONMED has refined the concept and utilized today's technology to produce the finest machine of its kind.

Safe and simple to use, the HYFREATOR® 2000 has a wide range of applications - from dermatology and gynecology to ophthalmology and urology. The HYFREATOR® 2000's state of the art electronic circuitry utilizes two microprocessors to provide unsurpassed output power accuracy and patient safety. Whether it's full power for broad surface coagulation, or low power in one-tenth watt increments for delicate facial procedures, the HYFREATOR® 2000 provides the precision you demand. Internal self-diagnostic tests are performed every time you turn on the HYFREATOR® 2000 and the power output is monitored continuously during operation. This makes the HYFREATOR® 2000 one of the safest office-based electrosurgery units in the world. Compatible with your existing HYFREATOR® accessories, such as bipolar forceps and reusable electrodes, the HYFREATOR® 2000 features an ergonomic design and contemporary style that complements modern office decor.

Section 1 - Inspection

The CONMED HYFREATOR® 2000 has been thoroughly tested and inspected before shipment from the factory. Please check the unit before using for any damage that may have occurred in transit to you. If any damage is evident, please immediately contact the Authorized CONMED Distributor from whom you purchased the unit.

In addition, please compare the accessories you receive with the standard accessories listed below. If an item is missing, please notify your CONMED Distributor.

To activate your warranty, return the enclosed warranty card to CONMED Corporation within 10 days of receipt of your invoice.

Standard Accessories

Description	Catalog Number
Starter box of Non-Sterile, Electrolase® Blunt Tips	7-101-12
Starter box of Non-Sterile, Electrolase® Sharp Tips	7-100-12
Power Up\Down Switching Handle and Cord	7-800-5
Non-Sterile Sheaths	7-796-18
Sterile Sheaths	7-796-19
Wall Mount Kit	7-796-20
Operator's Manual and Warranty Card	7-900-OM
Common Dermatologic Procedures Videotape	7-900-21

Section 2 - Safety Precautions and Warnings

Users are warned against the use of the HYFREATOR® 2000 on patients with implants such as metal pins, metal joints, etc. Check with attending physician for patient's medical history before using the HYFREATOR® 2000.

The use of the HYFREATOR® 2000 on patients with cardiac pacemakers is potentially hazardous. The high frequency energy of the HYFREATOR® 2000 output may interfere with the action of the pacemaker. Precautions should be taken to ensure that the patient's well-being is maintained in the event of such interference. We recommend that the manufacturer of the pacemaker be consulted for advice before using the HYFREATOR® 2000 on a patient with a pacemaker. These precautions also apply to clinical personnel with cardiac pacemakers.



Electrosurgery should NEVER be performed in the presence of flammable anesthetics, flammable prep solutions or drapes, oxidizing gases such as Nitrous Oxide (N₂O), or in oxygen-enriched environments. The risk of igniting flammable gases or other materials is inherent in electrosurgery and cannot be eliminated by device design. Precautions must be taken to restrict flammable materials and substances from the electrosurgical site, whether they are present in the form of an anesthetic, life support, skin preparation agent, or are produced by natural processes within body cavities, or originate in surgical drapes, tracheal tubes, or other materials. There is a risk of pooling of flammable solutions in body depressions such as the umbilicus and in body cavities, such as the vagina. Any excess fluid pooled in these areas should be removed before the equipment is used. Attention should be called to the danger of ignition of endogenous gases. Some materials, for example, cotton, wool and gauze, when saturated with oxygen may be ignited by sparks produced in normal use of the Hyfrecator ® 2000.

To avoid alternate site burns or potential shock, remove all metal objects from treatment area before using the HYFREATOR® 2000. It is not advisable to use this instrument in the proximity of jewelry, eyeglasses, digital watches, portable radios, pocket calculators, hearing aids, etc.

Do not use monopolar electrosurgery on small appendages or other parts of the body having a relatively small cross sectional area, as in circumcision or finger surgery, as it can cause thrombosis and other unintended injury to tissue proximal to the surgical site. IEC 60601-2-2 (3rd Edition) indicates the use of bipolar techniques may be desirable for use in those situations in order to avoid unwanted coagulation. Note, however, that AAMI Standard HF18-1993 currently contraindicates both monopolar and bipolar electrosurgery for circumcisions.

The tips of recently activated accessories may be hot enough to burn the patient or ignite flammable material. Temporarily unused active electrodes should be stored in the holder on the Hyfrecator® 2000 or in an electrically insulated, flame resistant container to prevent injury due to hot tips or accidental activation of the footswitch. The unused active electrode should never be placed on the patient.

The output power selected should be as low as possible and activation times should be as short as possible to achieve the desired surgical effect.

Electrosurgical leads (active, bipolar or return) should not be allowed to contact the patient, staff, or other electrical leads connected to the patient.

When uncertain of the proper control setting for the power level in a given procedure, start with a low setting and increase as required.

Do not place liquid containers on top of the unit. Wipe spilled liquids off the unit immediately. To prevent inadvertent entry of liquids, do not operate this unit except in its normal upright position.

To prevent cross-infection, do not reuse disposable (single use) accessories.

Used electrosurgical tips should be disposed of as sharp biological hazards per your local and hospital regulations.

Studies have shown that smoke generated during electrosurgical procedures may be harmful to surgical personnel. These studies recommend using a surgical mask and adequate removal of the smoke using a surgical smoke evacuator or other means.

Interference produced by the operation of the Hyfrecator® 2000 may adversely influence the operation of other electronic equipment.

Regularly inspect accessories for damage. In particular, electrode cables and endoscopically used accessories should be checked for possible damage to the insulation.

Use only accessories that have been approved for use with the Hyfrecator® 2000. Do not use accessories that fail to meet the minimum peak voltage requirements per Fig 11 , Peak Voltage vs. control settings. It is recommended to use only accessories rated at the maximum peak voltage, for a given mode.



Failure of the unit could result in an unintended increase of output power.

When used, the neutral electrode (patient plate) should be reliably attached with the entire surface area in contact with the patient's body and as close to the operating field as possible. When not in use, the neutral electrode should be disconnected from the Hyfrecator® 2000 to avoid accidental burns.

Apparent low output or failure of the Hyfrecator® 2000 to function correctly at normal operating settings may indicate a faulty green wire ground connection. This could be due to a faulty power cord, loose connections inside the unit, the use of a two wire extension cord, or the use of a three-to-two prong adapter. These faults can result in a burn if the patient plate is used and is not in good contact with the patient. If the neutral electrode (patient plate) is being used, the low power may be due to faulty application or poor contact in its connections. In this case, the application of the neutral electrode and its connections should be checked before selecting a higher power.

Skin to skin contact (for example, between the arms and body of the patient) should be avoided by the insertion of dry gauze or other suitable means.

When the Hyfrecator® 2000 and physiological monitoring equipment is used simultaneously on the same patient, any monitoring electrodes should be placed as far as possible from the surgical electrodes. Needle monitoring electrodes are not recommended. In any case, monitoring systems incorporating high frequency current limiting devices are recommended.

The use of flammable anesthetics or oxidizing gases such as nitrous oxide (N₂O) and oxygen (O₂) should be avoided if a surgical procedure is carried out in the region of the thorax or the head, unless these agents are sucked away or flammable anaesthetic-proof equipment is used. The Hyfrecator® 2000 is not flammable anaesthetic-proof equipment.

Do not use the Handswitched Pencil with a footswitch. The unconnected switch connector can arc to nearby objects or personnel and cause a burn.

Connect the generator electrical cord to a properly grounded receptacle. Do not use extension cords or two wire adapters.

Do not connect wet accessories to the generator.

The Hyfrecator® 2000 must be mounted vertically to reduce the possibility of spilled liquids entering the chassis and adversely affecting the safety of the unit.

Anesthesia

As in other types of surgery, the amount and type of anesthetic required for procedures depends upon the site of the operation and the tolerance of the patient. Small lesions can sometimes be removed without anesthetics when they are not in sensitive areas. Do not use explosive or flammable anesthetics due to the presence of the spark created by the HYFREATOR® 2000. Similarly, when the site is cleaned with alcohol or other flammable cleansing agents, dry the surface thoroughly before proceeding.

Monoterminal Shock

In all electrical devices where a current is emitted from the instrument, the current must have a return path. The return path for monoterminal applications is through the patient's body, to the ground and back to the instrument. In this mode, if any portion of the patient's body comes in contact with a grounded metal object, such as a chair or metal rail, the current will take the path of least resistance and a slight shock may be felt. To minimize the possibility of shocking during monoterminal applications:

- Do not let your patient come in contact with any grounded metal objects.
- Position the electrode on or close to the patient before activating the output.
- For procedures using the dispersive plate, do not allow the patient to break contact with the dispersive plate when the unit is activated.
- If the physician or nurse must touch the patient, place hand on the patient before activating the HYFREATOR® 2000. Do not break contact during activation. To lessen the possibility of a shock, wear gloves at all times and continue to avoid contact with grounded metal objects.



Section 3 - Operating Controls and Indicators

Figure 1: Front, Side and Bottom Panel Controls

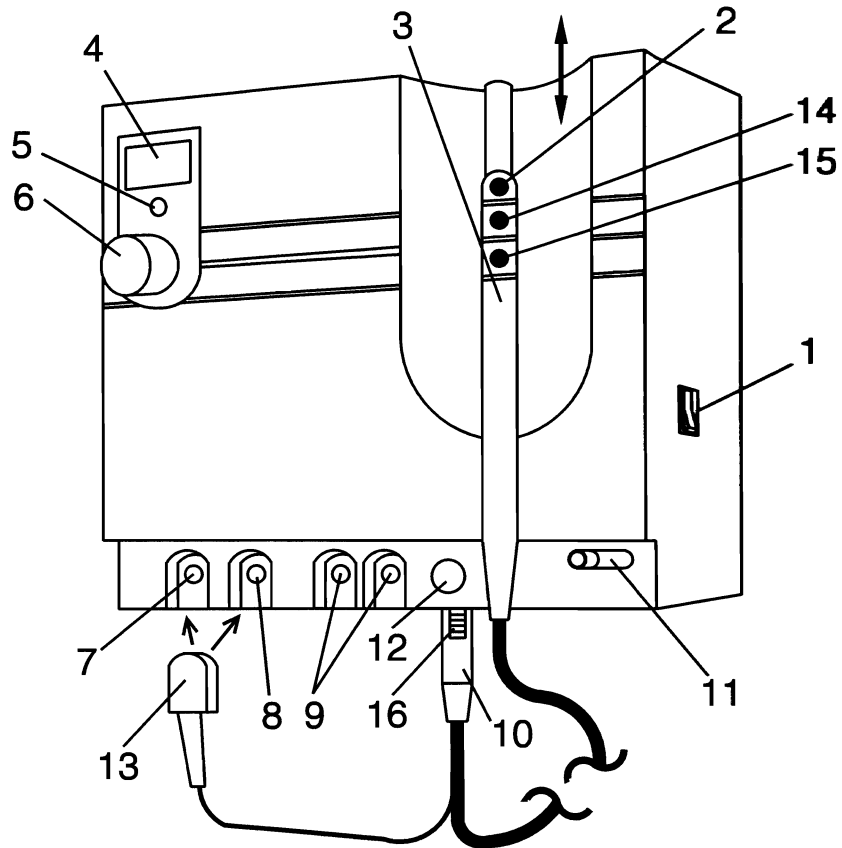

HAND-CONTROL SETUP

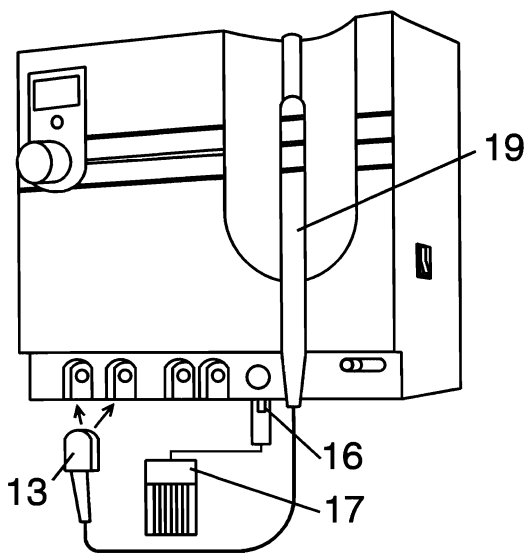

FOOT-CONTROL SETUP

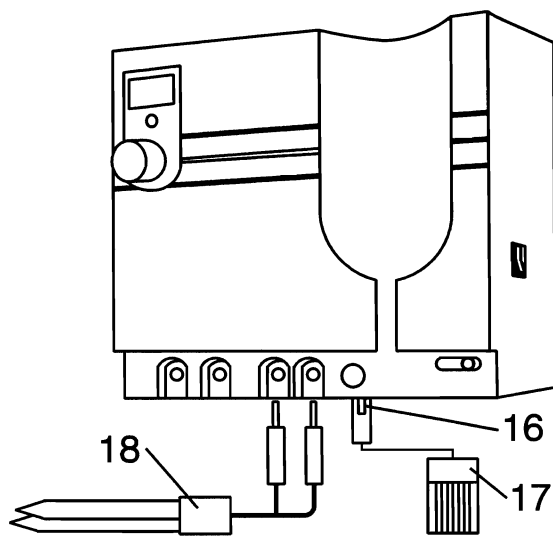

BIPOLAR SETUP



Front, Side and Bottom Panel Controls

1. **ON/OFF SWITCH**
Turns unit on or off. When the Hyfreicator® 2000 is turned on, the unit automatically “powers up” to the setting last used.
2. **POWER ACTIVATION BUTTON**
When pressed, high frequency energy is emitted from the electrode. Additionally, an audible tone is generated and the active “on” indicator light illuminates.
3. **POWER UP/DOWN SWITCHING HANDLE AND CORD**
Remove or insert the power handle in the indicated direction.
4. **POWER OUTPUT INDICATOR**
Displays the power setting for the mode presently selected. Each mode automatically retains it’s own independent power setting that is set when the mode is selected again.
5. **ACTIVE “ON” INDICATOR**
Illuminates when the power activation button is pressed.
6. **POWER KNOB**
Increase power by rotating clockwise; decrease power by rotating counter-clockwise. Power is advanced by one watt increments in High and Bipolar modes, and in the Low mode at a power level greater than 10 watts. Power is advanced in one-tenths of a watt when less than ten watts in the Low mode.
7. **HIGH OUTPUT TERMINAL**
Insert the power up/down switching handle and cord single pin into this outlet for heavy desiccation and fulguration procedures requiring high intensity. Provides between zero and 35 watts with high voltage.
8. **LOW OUTPUT TERMINAL**
Insert the power up/down switching handle and cord single pin into this outlet for light desiccation and fulguration procedures requiring low intensity. Provides between zero and 20 watts with a voltage lower than the high output terminal.
9. **BIPOLAR OUTPUT TERMINAL**
For coagulation procedures using forceps. When using forceps, the forceps plug into both bipolar outlets (a footswitch is required when forceps are utilized). Bipolar provides between zero and 35 watts with a voltage lower than the high or low output terminals.
10. **SWITCHING CONNECTOR**
The power up/down switching handle and cord socket plugs into this connector.
Be sure to align the connector pins before inserting.
NOTE: The optional footswitch plugs into this same connector.
11. **TERMINAL SELECTOR SWITCH**
Selects the desired output terminal and output mode. Output displayed will be the last setting used.
12. **PATIENT PLATE**
If a patient plate (also called neutral electrode or dispersive plate) is required or preferred for High or Low mode operation, depending upon the surgical procedure, simply plug the dispersive plate into this connector.
13. **RF PLUG (Single Pin Accessory Plug)**
Used to connect the HI or LO output terminal to the handle. This plug must be connected to an Output terminal for the pencil to deliver current. Note that both the Handswitching and Footswitching Pencils use the same RF plug connection.
14. **POWER UP BUTTON**
Press this button to increase the power setting for the selected mode.

(continued on next page)

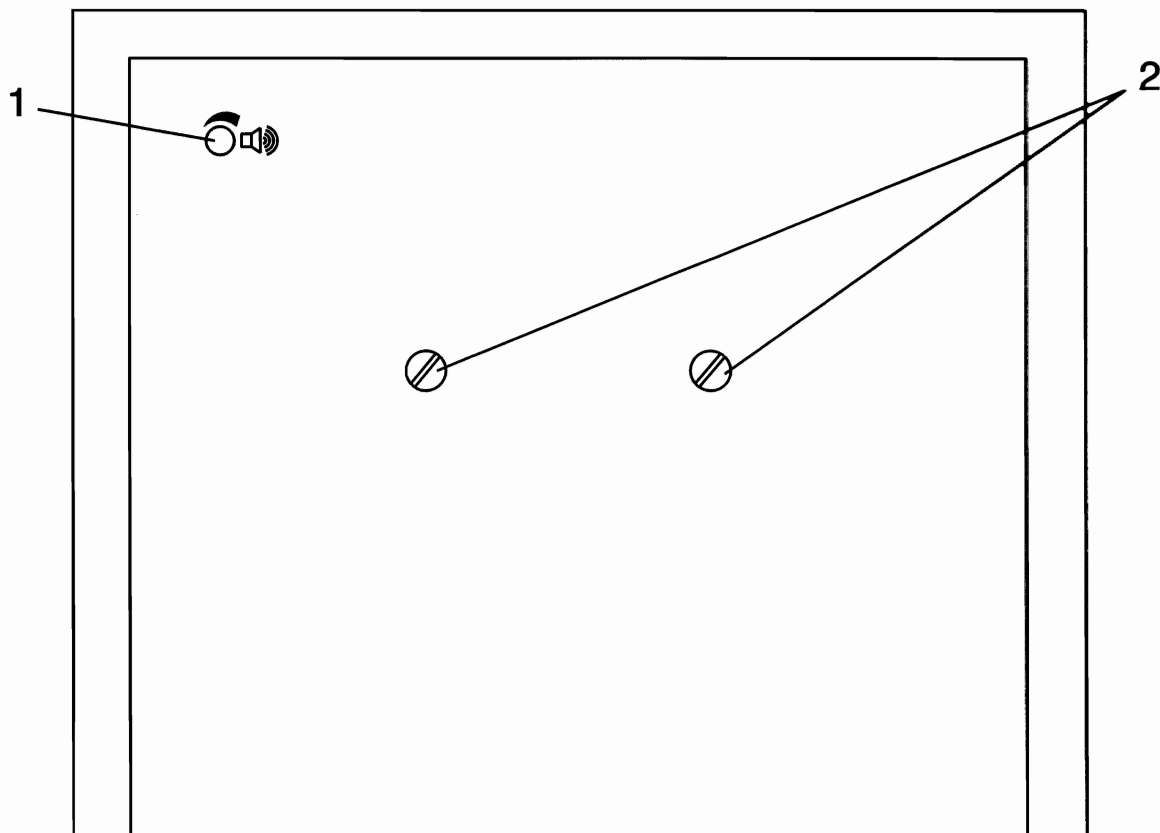

Figure 2: Back Panel Controls

**15. POWER DOWN BUTTON**

Press this button to decrease the power setting for the selected mode.

16. RELEASE BUTTON

To remove an accessory switching connector, press this button to release the accessory, then pull the connector straight away from the unit.

17. FOOTSWITCH

Used to activate the unit when a Footswitched Pencil or Bipolar Forceps are used.

18. BIPOLAR FORCEPS

Must be used with a footswitch for activation.

19. FOOTSWITCHED PENCIL

Use when footswitch activation is preferred.

Back Panel Controls**1. VOLUME CONTROL**

Adjusts volume of the audible tone generated when the power activation button is pressed. To increase volume, insert a screwdriver and rotate clockwise until resistance is felt. Do not force adjustment past the resistance point. For safety reasons, the tone cannot be completely turned off.

2. WALL MOUNTING STUDS

Used with standard wall mounting kit, Cat. No. 7-796-20 (see the mounting kit for instructions). Instrument may also be mounted on optional mobile pedestal stand (Cat. No. 7-796-1). Note: The 7-796-20 mounting kit must be used to mount the unit on the mobile pedestal stand.



Section 4 - Operation of Your Instrument

1. The Hyfrecator 2000® should be mounted vertically with at least 2" (5cm) clearance around the top and sides of the unit. Approximately 5" (13cm) should be allowed at the bottom of the unit for access to the accessory connections. Adjust the volume to an acceptable level before mounting, because the volume control is at the back of the unit. Refer to the supplied Wall Mount Kit, or optionally, the Mobile Pedestal Stand instructions for additional information.
2. Verify that the Hyfrecator 2000® is the correct mains voltage and frequency by checking the serial number plate on the back of the unit.
3. Plug power cord into connector on the bottom of the HYFREACATOR® 2000.
4. Plug power cord into a grounded electrical outlet. A solid ground is necessary for safe and effective operation of the Hyfrecator 2000®.
5. Align and insert the four-pin connector from the switching handle or the footswitch into the connector on the bottom of the unit. To release the connector, press the release button and pull.
6. Slide Mode Selector Switch to HI, LO, or BI as indicated for the procedure. NOTE: This selection will also preset the power setting last used in that mode. These settings are retained, even when the unit is turned off.
7. Insert the RF Plug (for HI or LO operation) or the Bipolar plugs (for Bipolar operation) into the output jack(s) uncovered by the Mode Selector Switch.
8. Insert an Electrolase® Disposable Electrode or other Hyfrecator® accessory electrode into the active end of the switching handle.
9. Turn the on/off switch to the "on" (or "1") position. The HYFREACATOR® 2000 will then begin a self-diagnostic test sequence. During this time, the HYFREACATOR® 2000 will perform various function and safety checks. These tests consist of a rotating pattern appearing in the Power Output Indicator, and four brief beeps before the last used power setting appears. NOTE: If a fault is detected during these tests, a continuous tone will sound and a Fault Code will appear in the Power Output Indicator. Refer to Section 12 in this manual if a fault occurs.
10. Adjust the power output for the selected mode to the desired wattage using either the Power knob on the front panel or the UP/DOWN buttons on the power switching handle. This adjustment only affects the selected mode. The power output setting will be retained permanently upon activation or after 3 seconds of inactivity. NOTE: The power output controls have a rapid speed feature to make large power changes. Rapid speed is engaged by holding down either the up/down buttons or by rapid rotation of the power knob. Fine adjustment is achieved by brief button presses or by slow power knob rotation.
11. The selected output will be sent to the accessory electrode upon pressing either the pencil activation button (for handswitching accessories); or the footswitch (for footswitching accessories). Activation is indicated by the blue light and a continuous audible tone. Note: Tone volume may be set to the desired level, but not silenced, by the screwdriver adjustment on the rear of the unit.
12. When the procedure is complete, turn the on/off switch to "off" (or "0") position.

Section 5 - Suggestions for First-Time Operation

Before using the HYFREACATOR® 2000 clinically, we suggest the following experiment:

Hold a quarter-pound piece of room temperature beef or chicken firmly in hand or place it on a table and touch it with your hand to improve the path of electrical flow. Starting with a low power setting, experiment as follows. (If you are not familiar with desiccation, fulguration or coagulation, please see the Terminology for Procedural Configuration section):

- **Desiccation:** In the monoterminal without a dispersive plate mode, using an Electrolase Tip, touch the meat and turn on the current for one to five seconds. Use different intensities with the low and the high output terminals. Cut the meat open with a scalpel and view the depth of penetration. A mild blanching of the tissue is sufficient for most conditions.



- **Fulguration:** Using either the low or high output terminals, bring the electrode near, but not touching the meat (one to three mm). Use various settings and observe the different degrees of fulguration that can be produced. Short bursts of a spark alternated with short cooling periods are most acceptable to the patient. Continuous application of the spark creates heat that may become intolerable. Cut the meat open at the fulgurated spots to view the relatively shallow effect.
- **Coagulation:** If you have purchased the optional cord and dispersive patient plate or the forceps and footswitch, you may wish to experiment with the effects of monoterminial and bipolar coagulation. You will find that monoterminial coagulation produces very deep effects while bipolar coagulation produces relatively superficial effects.

A training tape covering basic dermatological procedures utilizing the HYFREATOR® 2000 is included with the unit. Additional copies are available from your Authorized CONMED Distributor (Cat. No. 7-900-21).

Section 6 - Terminology for Systems Configuration

Monoterminial (monopolar) without Dispersive Plate

The vast majority of HYFREATOR® 2000 procedures use monoterminial techniques without a dispersive plate. They are easily set up, provide excellent results and do not require any accessory equipment. The current flows from either the high or low output terminals to the electrode, then passes to the patient. The electricity "completes the circuit" by seeking its own ground through the patient to the table and across the floor, returning to your unit via the electrical outlet (see Figure 3). Monoterminial procedures without a dispersive plate produce desiccation and fulguration.

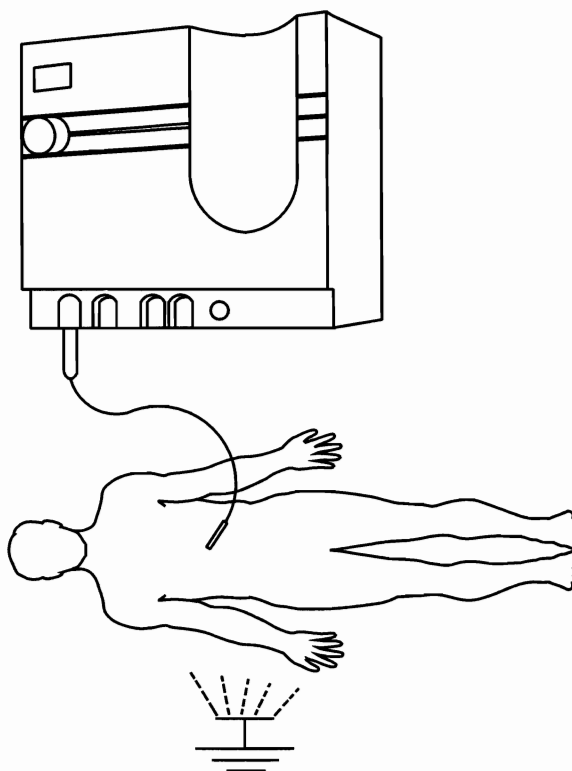

Figure 3: Monoterminial Without a Dispersive Plate Configuration



Monoterminal (Monopolar) with Dispersive Plate

Monoterminal applications with a dispersive plate (See Figure 4) are less common than monoterminal applications without a dispersive plate. Here, the high-frequency current starts from either the high or low output terminals, then travels through an electrode to your patient, where it exits through the dispersive patient plate and returns directly to the unit. Monoterminal applications with a dispersive plate improve the coagulation efficiency by providing a better path for the current flow. Its use is indicated when more effective coagulation is desired. The power setting should be reduced when a dispersive plate is used until the surgeon becomes accustomed to the increased coagulation efficiency that the dispersive plate provides. NOTE: The bipolar terminals should not be used in this application.

It is important that the dispersive plate has maximum contact area with the patient, and that contact is maintained whenever activation occurs. Do not allow the patient to break contact while the unit is activated, or a burn could result at the last point of contact.

Place the dispersive plate under a well vascularized muscle mass that is thoroughly clean and dry. Clean and shave site as necessary to provide adequate electrical connection. Avoid placement over scar tissue, bony prominences or other areas where pressure points on small areas might develop.

Bipolar

For bipolar configurations, the current flow is similar to monoterminal techniques, except the electricity never spreads deeply into the tissue. Instead, forceps - or other highly specialized electrodes - keep the current flow on the surface, travelling from one tine of the forceps to the other (see Figure 5). Bipolar techniques produce coagulation and are recommended for procedures requiring more efficient coagulation or hemostasis. NOTE: Bipolar forcep procedures require the use of a footswitch.

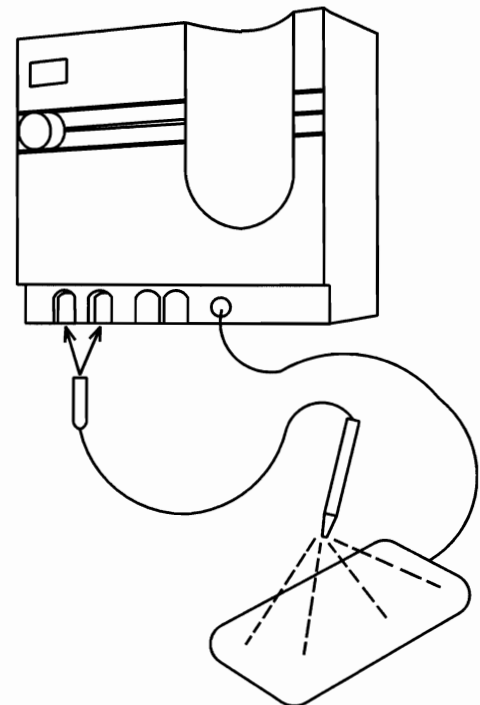

Figure 4: Monoterminal with Dispersive Plate Configuration

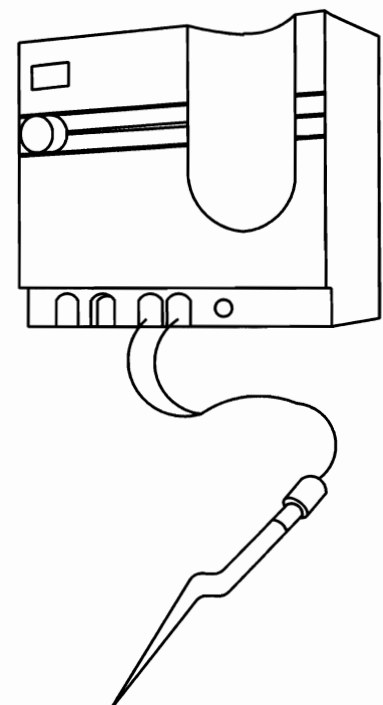

Figure 5: Bipolar Configuration



Section 7 - Terminology for Procedural Configuration

Desiccation

Desiccation comes from the Latin word “desiccare”, meaning to dry. It is a monoterminial ~~without a~~ dispersive plate technique. The electrode either touches, or is inserted into the tissue. ~~The current evaporates~~ the cellular fluids, blanching the area treated (see Figure 6). Typically, the depth of blanching is ~~greater with~~ desiccation than with fulguration.

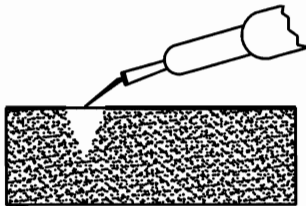

Figure 6: Desiccation

NOTE: Continued electrodesiccation at increased intensity will result in tissue destruction ~~and clearing~~.

NOTE: Epilation by thermolysis is a special form of desiccation where a fine-wire electrode ~~(product~~ number 714) destroys hair follicle. This procedure uses the low terminal at very low power ~~settings~~ (see Figure 7).

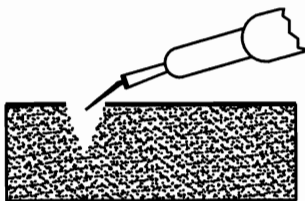

Figure 7: Epilation

- Application - As the power and/or time of treatment increases, the amount of ~~desiccation also increases~~. You must, however, consider the effects of the size of the electrode, especially ~~when inserting an electrode~~ needle. For instance, a large diameter needle requires more power and time to ~~produce the same effect as a~~ small needle.
- Healing - Small lesions usually heal completely in one to three weeks. First, ~~granulation forms on the base~~, then epithelializes. A crust forms and sloughs off in seven to ten days. ~~Large lesions may produce two to~~ three successive crusts.

NOTE: In an area of good blood supply and abundant subcutaneous tissue, ~~healing will be rapid~~.

- Post-Operative Care - Small lesions may not require dressing. Larger areas of ~~destruction will require~~ antiseptic dressing and medication until the wound is epithelialized. As in ~~any surgical procedure~~, large open wounds should be protected against secondary infection.



Fulguration

Fulguration comes from the Latin word “fulgur”, meaning an act of lightning. It is a monoterminal without a dispersive plate technique where the electrode is held slightly away from the surface being treated (see figure 8), resulting in sparking to the surface. When delicately fulgurating, you must precisely position the point of the active electrode close to the area being treated or the electrical arc may divert to adjacent tissue areas. If desired, you can quickly fulgurate broad areas by holding the electrode further from the skin. Fulguration limits tissue destruction to a shallow area under the spark and is normally characterized by an eschar.

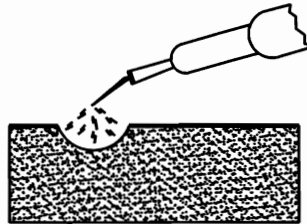

Figure 8: Fulguration

- Application - Factors such as power, treatment time, electrode size and the moisture content of the tissue influence the area and depth destroyed with one application. Additionally, the distance between the electrode and the tissue is important.
- Post-Operative Care - Same as desiccation.
- Healing - Same as desiccation.

Coagulation

Coagulation derives from the Latin word “coagulare”, meaning to clot. As seen in Figures 9 and 10, there are two types of coagulation:

Monoterminal Coagulation - Uses the dispersive patient plate (also called a “return electrode” or an “indifferent electrode”) as seen in Figure 9.

Bipolar Coagulation - A technique where the current flows between two closely placed electrodes as seen with the forceps in Figure 10. A dispersive patient plate is not used.

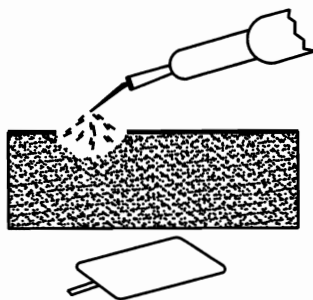

Figure 9: Monoterminal Coagulation

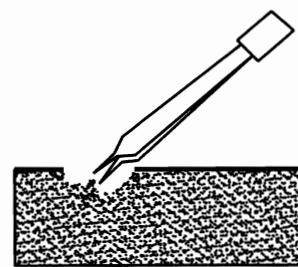

Figure 10: Bipolar Coagulation



- Application - The two types of coagulation have different effects on tissue. In the first case, the dispersive patient plate deeply draws the current into the tissue. The current efficiently flows through the patient back to the HYFRECATOR® 2000 producing heavy dehydration at the electrode site. Conversely, the use of bipolar forceps during bipolar coagulation produces the least tissue damage with the current remaining on the surface as it flows from one tine to the other.
- Healing - same as desiccation.
- Post-Operative Care - same as desiccation.

Section 8 - Applications

Dermatology

BENIGN LESIONS

The HYFRECATOR® 2000 can destroy a variety of benign skin lesions. With its wide range of power settings, the HYFRECATOR® 2000 treats even the most delicate facial lesions as well as the thickest scaling lesions of the trunk. Some of the clinical applications include:

- **Acrochordon (skin tag):** Electrodesiccation or fulguration quickly destroys these lesions. The remaining char is removed with a gauze pad or curette.
- **Actinic Keratoses:** These pre-malignant lesions respond well to light electrofulguration. Since these lesions occur on exposed surfaces, a cosmetic result is essential. Using a low power setting will help you control the destruction and ensure a satisfactory cosmetic result.
- **Adenoma Sebaceum:** Treat each papule with desiccation using a low power setting.
- **Angiokeratoma:** Superficial desiccation is generally sufficient.
- **Angiomas, Capillary:** Superficial desiccation or fulguration is usually quite successful in treating these lesions. The remaining char may be wiped away with a gauze pad.
- **Angiomas Cavernous:** Electrodesiccation may satisfactorily treat small lesions. Multiple needle insertions are usually necessary.
- **Angiomas, Spider:** Electrodesiccation of the centrum, from which the telangiectatic vessels radiate cosmetically, removes the lesions.
- **Condyloma Acuminatum (Venereal Wart):** Condylomata respond quickly to electrofulguration. Anesthesia is generally required and care must be taken to avoid post-operative infection in the warm, moist genital area.
- **Fibroma:** Light electrodesiccation or fulguration easily destroys small pedunculated fibromas.
- **Keratoacanthoma:** After a deep shave or "scoop" biopsy for diagnosis, the base of this lesion should be electrofulgurated to achieve hemostasis and destroy any residual tumor.



- **Lymphangioma:** These uncommon tumors may respond to electrodesiccation or fulguration.
- **Molluscum Contagiosum:** These viral lesions resolve quickly with electrodesiccation.
- **Pyogenic Granuloma:** This loose vascular tissue responds well to electrofulguration.
- **Seborrheic Keratoses:** These are perhaps the most common and most cosmetically annoying skin tumors in adults. Their presence is often associated with old age. Initial fulguration enables you to easily wipe away the charred remains with a gauze pad or gentle curette. The cosmetic result is usually excellent. Multiple small seborrheic keratoses of the face in young blacks (dermatosis papulosa nigra) may be treated without anesthesia using a low power setting. While excellent cosmetic results are achievable, it is prudent to initially treat one or two as a therapeutic cosmetic test.
- **Sebaceous Papules:** Seen in rosacea and older, oily-skinned patients, these lesions may be removed by light electrofulguration.
- **Syringomas:** Very light fulguration, followed by gentle curettage, may be curative. Test one or two lesions initially as a cosmetic trial.
- **Telangiectasias:** Facial telangiectasias respond well to gentle electrodesiccation. Use LOW terminal at low power settings at one or more sites along their length. This procedure has several advantages over more costly laser treatments and less controllable sclerosing injections. Leg lesions, however, are more recalcitrant to electrosurgery and more likely to recur.
- **Common Warts (Verrucae Vulgaris):** Most common warts respond to electrofulguration and curettage of the base. Special care must be given to warts that occur over specifically located nerves. Such sites include the digital nerves or those that occur on weight-bearing surfaces like the foot (Verruca Plantaris). Care should be taken to avoid excessively deep tissue destruction which may result in painful scarring.
- **Filiform Warts:** Electrodestruction of the pedicle near its base yields a high cure rate with excellent cosmesis.
- **Flat Warts (Verrucae Plana):** Flat warts respond well to light electrofulguration.

MALIGNANT LESIONS

If malignancy is suspected take a biopsy before treatment by electrosurgery for histopathologic examination. The most common skin cancers are basal and squamous cell carcinomas. Appropriately selected ones may be treated easily, quickly and effectively with curettage and electrofulguration. You usually need to repeat the procedure once or twice at the same sitting to achieve a high cure rate. The tumors you wish to treat generally should be less than two centimeters in diameter, occurring on a sun-exposed site (face, arms, upper back, lower legs) and not involving a body fold (such as the alar groove or inner canthus of the eye). When lesions are chosen appropriately, as noted above, very acceptable cure rates for electrosurgery can be achieved. In addition, electrosurgery has the advantage of being easy to learn, simple to perform and cost-effective. Cosmesis is quite acceptable and, in many cases, may be preferable to the cosmetic results of excisional surgery or radiotherapy.

- **Basal Cell Carcinoma:** Obtain a shave biopsy before electrosurgery. After initial tumor delineation with a curette, fulguration is performed and followed by thorough removal of the necrotic debris with additional curettage. Curettage and fulguration is typically repeated once or twice.



- **Bowen's Disease (Squamous Cell Carcinoma in Situ):** These lesions respond to the same techniques for basal cell carcinomas. Since these lesions may extend further laterally than they clinically appear, anesthesia should extend one to two centimeters beyond the visible lesions.
- **Bowenoid Papulosis:** Occurring on the genitals, these papules respond to electrofulguration.
- **Squamous Cell Carcinoma:** The same techniques are again employed as with basal cell carcinoma. You should only treat lesions arising in sun-damaged areas. Squamous cell carcinomas arising in non-sun-exposed skin and in mucous membranes are more aggressive biologically.

Plastic Surgery

Many surgeons use the HYFREATOR® 2000 for hemostasis in plastic and reconstructive surgery. It saves time and produces minimal tissue reaction compared to other methods. Coagulation occurs by touching each bleeding point with an electrodesiccating current. Because blood will dissipate the energy, a sponge should be used prior to application.

Gynecology

- **Vaginal Cysts:** Treat these cysts by first excising an oval strip and emptying the contents, then use a strong desiccating current to cauterize the interior. Gartner cysts extending near the vault and alongside the cervix respond to this method.
- **Condylomata of the Vulva:** You can effectively destroy these warts as you would destroy the various types of warts on the surface of the body. (see Venereal Warts under Dermatology and Urology).
- **Cervical Polyps:** Cervical polyps up to two centimeters in diameter respond to desiccation of the base without the need for a local anesthetic. If shallow, a fulgurating spark may blanch them thoroughly. Polyps extending into the cervical canal may require more than one treatment. Remember that endocervical and intrauterine polyps may be present. Dilation and curettage of the uterine cavity under general anesthesia may be indicated. As with all such lesions, preliminary biopsy is advisable.
- **Pruritus Vulvae:** By fulgurating the entire surface using a strong current, excellent results can be achieved. Take care to prevent urethral stenosis.
- **Urethral Tumors:** The majority of urethral tumors are benign and respond readily to desiccation. However, treatment should be thorough to avoid recurrence.
- **Cervical Erosion:** Many cervical erosions are asymptomatic and require no treatment. However, if the erosions produce symptoms such as increased discharge or pain, you should treat them effectively with desiccation, fulguration or coagulation. Typically, this is done without the need for a local anesthetic.
- **Cervicitis:** A strong desiccating current effectively destroys the entire infected mucosa, although more than one treatment is usually necessary.
- **Bartholin's Cysts or Abscesses:** Aspiration alone may cure the condition, if this fails, incise the cyst or abscess, evacuate its contents and coagulate the cyst wall using a fulgurating spark. Recurrent cysts respond to marsupialization.
- **Nabothian Cysts:** Puncture these infected glands and cysts with a sharp needle point, then desiccate.
- **Skene's Glands:** Insert a sharp point into the abscess or cyst, then desiccate using a strong current. The wound closes by granulation.



Dental and Oral Surgery

- **Apicoectomy:** To prepare for an apicoectomy, insert a fine desiccating needle electrode (Cat. No. 705A) slightly beyond the apex of the tooth, then apply the desiccating current to the infected area. The resulting coagulation reduces capillary bleeding and minimizes the spread of infection during later root resection.
- **Buccal Gingival Caries:** Soft, infected gingival tissue responds to desiccating currents.
- **Cysts, Mucous:** Small cysts of the mouth respond to epilation. An application of the desiccating current for a few seconds will boil out the mucous fluid and destroy the cyst lining. Results are excellent with minimal scarring.
- **Dentin Desensitization:** Fulguration desensitizes hypersensitive exposed dentin. Spray the area with a topical anesthetic before the first treatment, then fulgurate with a weak current. Only two treatments are usually required.
- **Frenectomy:** Intense fulguration of the superfluous tissue under local anesthesia reduces abnormal labial frenum.
- **Hemostasis:** To control bleeding after exodontia, desiccation or fulguration with a small ball electrode (Cat. No. 727) can be most effective.
- **Gingivectomy:** The removal of gingival tissue, such as the exposure of the gingival margin, the preparation for taking hydrocolloid impressions and papillectomies and the elimination of gum flaps, responds to both electrodesiccation and fulguration.
- **Root Canal Sterilization:** The dental electrode (Cat. No. 705A) can sterilize the pulp chamber after first removing the debris. Use one-second bursts of fulguration and gradually move the electrode deeper into the chamber and root canal.

Ophthalmology

- **Chalazion (Meibomian Cysts):** To treat these cysts, first anesthetize the area. Next, incise and evacuate the cysts.
- **Entropion:** Treat each nodule by inserting a very fine needle point electrode (Cat. No. 714). Use a low-powered desiccating current. Treat only a small portion at each session.
- **Xanthelasma:** These cholesterol deposits respond effectively to light desiccation or light fulguration. Several treatments are preferable to avoid any scarring.
- **Burn Entropion:** Light fulguration is recommended.
- **Spastic Entropion:** Following surgical incision and desiccation to separate it from the orbicularis oculi muscle, desiccate the muscle lightly until it is a light brownish-green color. Suture and dress the wound with antibiotic ointment.



Otolaryngology

- **Adenoid - Hypertrophied Remnants:** Coagulate small areas under local anesthesia and repeat the process until the hypertrophied areas are completely destroyed.
- **Epistaxis:** Electrodesiccation is very effective for hemostasis. Anesthetize the areas and carefully identify the vessels. Bring the electrode into direct contact with the ruptured arteriole and use a light current. Exercise care to avoid excessive tissue damage that could result in perforation of nasal septum. For that reason, it is inadvisable to treat both sides simultaneously.
- **Granular Pharyngitis:** Desiccate each point using a mild desiccating current.
- **Nasal Polyps:** Desiccate these polyps at the base.
- **Hemostasis in Tonsilloadenoidectomy:** Use either monoterminial or monopolar coagulation. The monoterminial technique uses the HIGH output. Bleeding is controlled with a sponge dampened with epinephrine (Adrenalin) 1:1,000 before activation of the electrode. Use a ball electrode (Cat. No. 727) as the active electrode.
- **Tonsil Tag Destruction:** Bipolar coagulation, using a specialized electrode (Cat. No. 789CC), can destroy tonsillar tissue. Insert the double needles into the tissue and destroy the tissue between them.
- **Turbinate Shrinkage:** Use either monoterminial or monopolar coagulation. The monoterminial mode uses a fine needle with a long, insulated sheath (Cat. No. 716). Monopolar coagulation uses the same electrodes along with the Dispersive Patient Plate (Cat. No. 7-900-7) to complete the circuit.

Proctology

- **Fissure-in-ano:** Spray a fairly strong fulgurating current over the involved tissue. Healing is prompt, but there is some discomfort during the first three days. Do not destroy the tissue too deeply. Instruct your patient to keep the area clean and to apply an antiseptic ointment.
- **Hemorrhoids:** Some authorities advocate bipolar coagulation for office management of hemorrhoids. Individually distend the hemorrhoids with a fluid solution and then coagulate.
- **Ischiorectal:** Incise and drain these lesions, then desiccate the wall with strong current.
- **Papilloma:** Small papillomas readily respond by inserting a fine needle electrode, but a fairly strong current is needed. Larger polyps within the bowel are better treated with snares and an electro-surgical cutting current.

Urology

- **Bladder:** Desiccation or fulguration of various growths within the bladder are well established urological techniques. Use a cystoscope and a continuous flow of water. (Check with the manufacturer of your cystoscope to determine compatibility with the HYFREATOR® 2000).
- **Vasectomy:** After your patient has been anesthetized, the lumen of the vas deferens can easily be desiccated, minimizing any peripheral damage to the surrounding muscle layers.
- **Venereal Warts:** Venereal warts and other small polypoid tumors respond to desiccation. Insert the sharp, fine needle point electrode into the base of the growth, intermittently applying the current until the tissue mildly blanches. It is not necessary to remove the desiccated tissue, as epithelization occurs beneath it.



Section 9 - Maintenance

The HYFREATOR® 2000 should be tested by qualified service personnel on a periodic basis. CONMED suggests examination of the unit at least every 12 months.

NOTE: All internal service should be performed by qualified service personnel only.

External Cleaning

To keep your instrument performing at its best, external cleaning should be performed on a regular basis.

To clean the external case of the HYFREATOR® 2000 and the up/down switching handle and cord:

- Moisten a lint-free cloth with a mixture of mild soap and water.
- Clean all external surfaces with this solution.
- Dry all surfaces thoroughly using a clean, lint-free cloth.

Soap-based solutions, rather than harsh chemicals, are recommended cleaning agents for the HYFREATOR® 2000. Evaporative solutions are preferred so as to limit exposure of internal electrical components. Material characteristics of the unit do not allow for gas, steam or cold sterilization techniques.

Sterilization of Accessories

7-800-5 Handswitching Handpiece

NOTE: Do not autoclave the power up/down switching handle and cord, cat. no. 7-800-5.

Sterilization in an ethylene oxide gas sterilizer with EO/HCFC mixture has been validated in accordance with EN ANSI/AAMI/ISO 11135:1994, *Medical Devices - Validation and Routine Control of Ethylene Oxide Sterilization* for the following ETO cycle parameters:

Condition:	After removing the used electrode, remove any obvious debris accumulated during use from the handpiece and cable with a sponge or towel moistened with a mild soap and water solution. Rinse thoroughly with water and allow to dry. (Do not immerse in fluids.) Place the handpiece in a peel-pack breather bag and on an open tray.
Mixture:	EO/HCFC-124@90:10.
Concentration:	550mg/L minimum to 650mg/L maximum
Temperature:	130 degrees F (55 degrees C), not to exceed 145 degrees F (63 degrees C).
Vacuum:	25 inches Hg minimum to 27 inches Hg maximum.
Pressure:	12 psi maximum.
Time:	2 hours
Humidity:	30% RH minimum to 80% RH maximum.
Aeration:	8 hrs. @ 140 degrees F (60 degrees C) OR 12 hrs. @ 120 degrees F (50 degrees C).

For further information or instructions, please refer to the AORN Recommended Practices Committee's "Proposed Recommended Practices for Sterilization in the Practice Setting", published in *AORN Journal*, July, 1994 (Vol. 60, No. 1, pages 109-119) and/or ANSI/AAMI ST35:1991, *Good Hospital Practice: Handling and Biological Decontamination of Reusable Medical Devices*.



7-800-6 Footswitching Handpiece

The reusable, autoclavable footswitching handpiece is steam sterilizable (see instructions below). This accessory requires the use of a footswitch (Cat. No. 7-900-4) to activate the HYFREATOR® 2000.

Also note that if a footswitch is utilized, a sterile disposable non-switching handpiece (Cat. No. 137657) and a reusable adapter (Cat. No. 670-3) can be used with the HYFREATOR® 2000.

To steam sterilize footswitching handpiece and electrodes:

- Place accessories in autoclavable packaging or wrap with a cloth.
- Autoclave at 121°C (250°F) +/- 3°C (+/- 16°F) for 15 minutes minimum/20 minutes maximum.
- Remove accessories from the autoclave and allow to cool for 30 minutes minimum.

NOTE: It is not advisable to cold sterilize surgical electrodes due to potential corrosion.

NOTE: Non-sterile Electrolase® Tips are not validated for sterilization.

Do not attempt to sterilize these tips.

NOTE: Do not sterilize the footswitch (Cat. No. 7-900-4).

Section 10 - Optional Accessories

1. ELECTROLASE® (Cat. Nos. 7-100-12, non-sterile Electrolase® Sharp, 7-100-8, sterile Electrolase® Sharp, 7-101-12, non-sterile Electrolase® Blunt, 7-101-8, sterile Electrolase® Blunt).

ELECTROLASE® TIPS - THE SOLUTION TO CROSS CONTAMINATION & ACCIDENTAL NEEDLE STICKS

Contrary to popular belief, the use of an electrodesiccator does not self-sterilize the electrode. For example, the British Journal of Dermatology reported that "Contaminated electrodes [with Herpes Simplex] were not sterilized by electrical discharge and virus transfer to skin samples was demonstrated after contact treatment." Also, according to a recent article in the Journal of the American Academy of Dermatology, the use of disposable electrodes can prevent the "transmission of hepatitis B and other viral-associated infections, such as AIDS."^{2,3}

Electrolase® Tips are disposable single use electrodes for use with your HYFREATOR® 2000. They offer a safe, economical solution to the threat of potential cross contamination or accidental transfer of a virus to you or your staff. For your convenience, Electrolase® Tips are available in both Sharp and Blunt configurations: the Sharp configuration is for pinpoint procedures and the Blunt configuration is for broad based coagulation. The tips are also available in both non-sterile and sterile packaging. Non-sterile Electrolase® Tips should be used in treating patient when a "hospital clean" environment is satisfactory. Sterile Electrolase® Tips are available for work requiring a "sterile field."

The HYFREATOR® 2000 comes with a starter box of non-sterile Electrolase® Sharp Tips and a starter box of non-sterile Electrolase® Blunt Tips.

2. HYFREATOR PENCIL SHEATHS: (Cat. No. 7-796-18). Disposable non-sterile, clear plastic sheaths protect the handpiece body from external contamination during procedures.
3. STERILE HANDPIECE SHEATH (Cat. No. 7-796-19) Disposable sterile, clear plastic sheaths protect the handpiece body from external contamination during procedures.



4. MOBILE PEDESTAL STAND (Cat. No. 7-796-1). Provides the ability to roll the HYFREATOR® 2000 from one location to another. The stable five-legged steel stand has a durable protective coating. This accessory requires the use of the wall mounting kit, cat. no. 7-796-20.
5. FOOTSWITCH: (Cat. No. 7-900-4). The Footswitch can be used to power activate the HYFREATOR® 2000. The Footswitch plugs into the switching connector at the base of the unit. A non-switching handle and cord or forceps delivers power to your patient. Most Hyfrecator users prefer the convenience and speed of hand switching pencils and footswitches are required only when you use certain specialized electrodes and handles such as forceps, or when you require extremely precise activation.
6. FOOT/NON-SWITCHING HANDLE AND CORD: (Cat. No. 7-800-6). Identical to standard switching pencil without the power activation and up/down buttons. This handle can be sterilized and requires the use of a footswitch.
7. DISPERSIVE PATIENT PLATE: (Cat. No. 7-900-7). Required for Monoterminal coagulation procedures. This stainless steel return plate requires no gels or adhesive.
8. DISPOSABLE HYFREATOR PENCIL AND ADAPTER: (Cat. No. 137657 for the pencil and 670-3 for the adapter). Sterile disposable pencil with 10-foot cord and needle electrode inserted. The pencil fits into the reusable adapter which fits into the desired output mode.
9. REUSABLE SUCTION COAGULATOR: (Cat. No. 137307). Busey Frazier Tip, reusable suction coagulator with detachable 10ft. cord.
10. BIPOLAR FORCEPS: A variety of reusable forceps are available for bipolar procedures. Ask your Authorized CONMED Distributor for details. Forceps require the use of a Bipolar Cord, Cat. No. 7-801-11
11. REUSABLE ELECTRODES: A variety of reusable electrodes for particular procedures are available. Ask your Authorized CONMED Distributor for details.
12. HYFREATOR® 2000 TRAINING VIDEO *Common Dermatologic Procedures* (Cat. No. 7-900-21). A 15 minute physician training tape covering basic dermatologic procedure such as the treatment of moles, warts, skin tags, seborrheic keratoses, telangiectasis and skin cancers.
13. HYFREATOR® 2000 SERVICE MANUAL (Cat. No. 7-900-SM): Contains parts lists, schematics, maintenance instructions, calibration procedures, theory of operation and troubleshooting guide. It is designed to be used with this manual.

Section 11 - Warranty

As manufacturer of the CONMED HYFREATOR® 2000 and other high quality medical equipment, CONMED warrants all of its products to be free from defects in material and workmanship under normal operation and use. The warranty period for the CONMED HYFREATOR® 2000 is twelve (12) months to the product's original owner.

NOTE: The warranty card must be returned by the original owner to CONMED within ten (10) days of receipt of the invoice.

A ninety (90) day warranty is provided for standard and optional accessories. The ninety (90) day warranty includes the power up/down switching handle and cord. There is no warranty on disposable, single-use items.

The warranty is limited to the repair or replacement (at the manufacturer's discretion) of any HYFREATOR® 2000 (or part thereof) that is returned to the manufacturer within the specified warranty period and which, after examination, is found to be defective.



Transportation of the HYFRECATOR® 2000 must be prepaid by the sender. The unit will be returned prepaid to the owner by the same manner of transportation used in shipping the product to the manufacturer.

The warranty does not apply to any product, or integral part thereof, that has been altered or serviced by anyone other than the manufacturer. Nor does it apply toward any product that has been damaged as a result of accident, abuse, misuse or negligence on the part of the user.

Section 12 - In Case of Difficulty

The HYFRECATOR® 2000 has two microprocessors for control and safety functions. If either of the microprocessors discovers a problem during the power on self-diagnostic check, the unit will inhibit operation and display an error code in the power display.

If an error code appears in the power display window (either "E0" through "E9" or "-0" through "-F"), turn the unit off and wait a few seconds before turning the unit back on. This may clear the problem.

If the error code is "E7", either one of the buttons on the Power Up/Down Switching Handle was pressed or the footswitch was activated when the HYFRECATOR® 2000 was turned on or the accessory is defective. Turn the power switch off and disconnect the accessory. If the HYFRECATOR® 2000 powers up normally without the accessory connected, the accessory is defective. Replace the defective Power Up/Down Switching Handle or the defective footswitch.

If the error code is "-7", the HYFRECATOR®2000 detected that either the activation button, or the Power Up/Down Switching handle was pressed, or the footswitch was activated while the output power was being changed. Do not attempt to activate the unit during power changes.

If the error code cannot be cleared, the unit must be returned for service. Refer to Section 13, Repair and Return Policy for instructions.

Section 13 - Repair and Return Policy

HYFRECATOR® 2000 units and any standard or optional accessories should not be returned to the manufacturer for warranty or non-warranty repair without prior authorization. A "Return Authorization" (RA) number will be issued by CONMED Customer Service department upon request. To receive an RA number, please call (800) 552-0138 or 303-699-7600, extension 5274, or fax 303-699-9854.

NOTE: Any merchandise returned to CONMED without a Return Authorization number will not be accepted by the receiving department and will be returned to the sender.

The CONMED Warranty and Return Policy for the HYFRECATOR® 2000 supersedes all other warranties either expressed or implied and shall be governed and executed under the laws for the State of New York, U.S.A.

Section 14 - Environmental Protection

The shipping container and packing material should be retained in the event the unit must be returned for factory service. At the end of the equipment's life, it should be disposed of in accordance with your local regulations. Component materials are:

- Thermoplastic enclosure and stainless steel mounting plate.
- Thermoset printed wiring boards containing miscellaneous electronic components.
- Power transformer made of steel and copper.
- Mains cord and pencil accessory made of thermoplastic and copper.
- Accessory electrodes are stainless steel and thermoplastic.
- Electrodes contaminated with biological waste should be disposed of as biologically hazardous material.
- Shipping container and packing material are a combination of cardboard and plastic film.



Section 15 - Specifications

PARAMETER

CHARACTERISTICS

Primary Power Requirements

Model 7-900-100	100V \pm 10% 50/60 Hz 0.9 A
Model 7-900-115	115V \pm 10% 50/60 Hz 0.8 A
Model 7-900-220	220V \pm 10% 50/60 Hz 0.5 A
Model 7-900-230	230-240V \pm 10% 50/60 Hz 0.5 A

Dimension and Weight

Depth:	4 inches (102 mm)
Width:	8.75 inches (222 mm)
Height:	7.5 inches (190 mm)
Weight:	6 pounds (2.7 kg)

Functional Characteristics

Mode	Max Power Setting (Watts)	Max Voltage (Vpp)	Rated Load (Ohms)	Repetition Frequency (KHz)
HI	35	8000	1000	24.4
LO	20	3000	500	32.3
BI	35	3000	500	32.3

Power Accuracy at Rated Load

LO and BI: 0 to 10 W: Greater of 90 mW or 10% of setting
10 to maximum setting: 10% of setting

HI: Greater of 1 W or 10% of setting

NOTE: Instrumentation errors can be great enough to exceed these limits. For best results, the same instruments should be used for calibration, as well as checking.

RF Frequency:	450 KHz \pm 50KHz (open circuit)
Output Wave Shape:	Clipped, damped sinusoidal
Line Regulation:	\pm 5% at at max. power for a \pm 10% line voltage
Duty Cycle:	Intermittent: 30 sec. on, 30 sec. off
Audio:	Adjustable from >45 dba to \geq 65 dba at 1 meter
Display Settings:	
Low Output Terminal	
0-10 range:	0.1 watt increments
10-20 range:	1 watt increments
Bipolar & High Output Terminals	
0-35 range:	1 watt increments
60 Hz Leakage:	50 microamps max. third wire of line cord open
Mains Power Cord:	18 AWG/3 105°C 300V / IEC-320-C13 connector, 10 ft. (3m)
Environmental	
Operating Temperature Range:	+10 degrees to +40 degrees C
Relative Humidity:	10% to 95% non-condensing
Storage Restrictions:	-40 degrees to +70 degrees C, 95% humidity N.C.

Approvals: UL 544, Medical and Dental Equipment, E68077
EN 60601-1 / IEC 60601-1

Protection: BF Defibrillator, Class 1

Specifications subject to change without notice.



Section 16 - Symbols



Power On/Off



CAUTION: To reduce the risk of an electric shock, do not remove the back cover of the instrument. Refer all servicing to qualified service personnel.



CAUTION: Site is a source of high voltage.



CAUTION: Before using instrument, read operating manual.



Equipment is classified as Type BF; it has an internal electrical power source that provides an adequate degree of protection against electric shock, particularly in regard to the allowable leakage current and the reliability of the Protective Earth connection.



Explosion risk if used with flammable anesthetics.



This equipment intentionally supplies non-ionizing RF energy for physiological effect.



Neutral electrode referenced to earth.



Lo Monopolar Coagulation



Hi Monopolar Coagulation



Bipolar Coagulation



Speaker Volume Control



RF Power Adjustment



Patient Plate Connection



Handswitch Connection

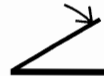

Footswitch Connection

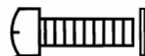

Wall Mount Screw Location

IPX1

Drip-proof Enclosure



Section 17 - Index of Reference Material

1. Clover, G.B. and Peutherer, J.E., "Herpes Simplex Virus Dispersal by Hyfrecator Electrodes," *British Journal of Dermatology*, Dec., 1987, Vol 177, p. 627.
2. Sheretz, E. F. et al, "Transfer of Hepatitis B Virus by Contaminated Needle Electrodes after Electrodesiccation in Simulated Use," *Journal of the American Academy of Dermatology*, Dec., 1986, Vol. 15, No. 6, p. 1246.
3. Sebben, Jack, E., Cutaneous Electrosurgery, *Year Book Medical*, Chicago, IL, 1988.

Section 18 - Performance Graphs

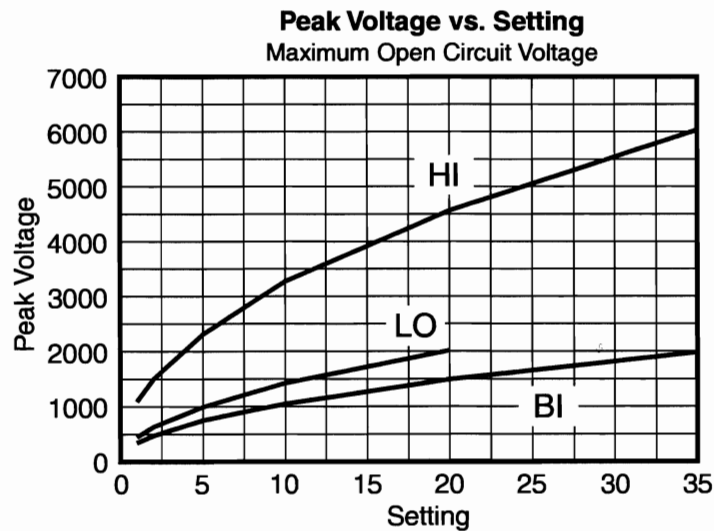

Figure 11

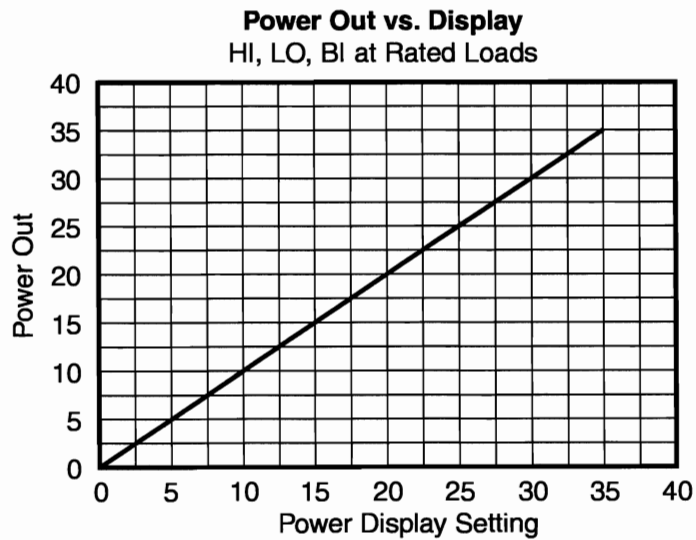

Figure 12



Figure 13: Load Regulation Curves

