

**CHAPTER 10
SUPPLEMENTAL INFORMATION**

10.1 INTRODUCTION

This chapter shall be a collection of Supplemental Memorandums expanding topics that require further explanation. Each supplement shall be contained in a subsequent section starting in section 10.2 and shall contain the title of the supplement and the date of issuance.

For example, 10.X Supplement on XYZ Topic/Item dated month/day/year. The issuer of the supplement memorandum shall always be the Bridge Inspection Engineer or the State Bridge Engineer. The supplement may also be in the form of an email sent to all individuals participating in the Bridge Inspection Program. All supplements shall be summarized in the table below and shall be continually updated in the table as well as in the succeeding sections.

Supplemental Memorandum Log Index		
Section Number	Supplemental Item	Date of Issue
Section 10.2	Coding for Multi beam bridges	05/01/2009
Section 10.3	Team Member Initials on Inspection reports	11/01/2009
Section 10.4	Superstructure Coding for NE Bulb Tee Pre-stressed Girder Bridges	01/15/2010
Section 10.5	Shielding Reporting and Coding	02/16/2011
Section 10.6	Coding Clarification for Parapets and Bridge Railing	11/12/2013
Section 10.7	Inspect What You Can...When It Is Due!	11/17/2014
Section 10.8	BRI: Definitions and Method of Measuring Length of Span	4/6/16
Section 10.9	NBIS Data Uploading Process Change	9/25/17

Chart 10-1: Supplemental Memorandum Log Index

10.2 CODING FOR MULTI BEAM BRIDGES ISSUED 5/1/09

THE COMMONWEALTH OF MASSACHUSETTS
MASSACHUSETTS HIGHWAY DEPARTMENT
INTEROFFICE MEMORANDUM

TO: Bridge Inspection Staff

THRU: Alexander K. Bardow, P.E., Director of Bridges and Structures 

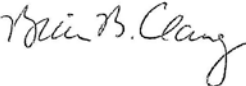
FROM: Brian B. Clang, P.E., Bridge Inspection Engineer 

DATE: May 1, 2009

RE: Coding for Multi Beam Bridges

There has been a bit of inconsistency with the inspection reporting for multi beam or multi girder bridges. I have noticed that inspectors will use either Item 59.1 Stringers or Item 59.4 Girders or Beams on their reports for these types of structures. This memo is an attempt to standardize our approach to coding these elements.

I recommend that longitudinal elements that span from superstructure to superstructure should be called Stringers (Item 59.1), whereas longitudinal elements that span from substructure to substructure should be called either Beams or Girders (Item 59.4).

In some cases how you define the supporting elements can get a little complicated. How should we define cross girders or bents? Should they be defined as superstructure or substructure? The key for me is the presence of bearings. Cross girders that are supported by bearings should be considered superstructure elements. The element that supports the bearings would be the substructure for that system. Bents should be considered to be substructure units.

The classic case for the use of stringer coding will be in a stringer/floorbeam structural system such as on trusses. The floorbeams are obviously considered to be superstructure elements. For Beam/Girder descriptions I offer the following clarification. If the beam/girder element is a rolled beam shape, then it should be referred to as "beam". If the beam/girder element is made of built-up components/shapes (welded, riveted, or bolted), then it should be referred to as "girder". A pre-stressed AASHTO type IV beam should be coded as a "beam". A larger pre-stressed shape like a New England Bulb Tee should be coded as a "girder".

There are probably structural systems that do not fit the above descriptions. For such cases use your best judgment based upon the guidelines offered above.

BBC/bbc

10.3 TEAM MEMBER INITIALS ON INSPECTION REPORTS ISSUED 11/1/09

THE COMMONWEALTH OF MASSACHUSETTS
MASSDOT, HIGHWAY DIVISION
INTEROFFICE MEMORANDUM

TO: Bridge Inspection Staff

THRU: Alexander K. Bardow, P.E., Director of Bridges and Structures 

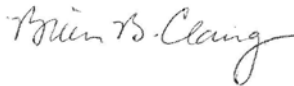
FROM: Brian B. Clang, P.E., Bridge Inspection Engineer 

DATE: November 1, 2009

RE: Team Member initials on Inspection Reports

Effective this date all inspection reports completed shall be initialed by each Team Member who assisted the Team Leader with the inspection. By initialing the report the Team Member confirms that he/she participated during the inspection and that the individual has read the final inspection report.

BBC/bbc

10.4 SUPERSTRUCTURE CODING FOR NE BULB TEE PRE-STRESSED GIRDER BRIDGES ISSUED 1/15/10

**THE COMMONWEALTH OF MASSACHUSETTS
DEPARTMENT OF TRANSPORTATION – HIGHWAY DIVISION
INTEROFFICE MEMORANDUM**

TO: Bridge Inspection Staff

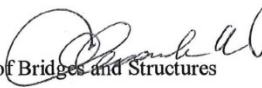
THRU: Alexander K. Bardow, P.E., Director of Bridges and Structures 

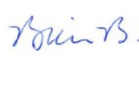
FROM: Brian B. Clang, P.E., Bridge Inspection Engineer 

DATE: January 15, 2010

RE: Superstructure Coding for NE Bulb Tee Pre-stressed Girder Bridges

There has been a bit of confusion about the correct coding for Pre-stressed concrete New England Bulb Tee girder superstructures. I have been advised that inspectors have questions on the correct coding for Item 43 – Structure Type. This memo will clarify our position.

Item 43 is a three digit entry. The first digit (material) is straight forward: either 5 - Pre-stressed concrete, or 6 - Continuous pre-stressed concrete. The confusion is in the second and third digit (design type). Inspectors have considered using either 02 – Girder, or 04 - Tee beam. The interest in calling it a tee beam bridge may lie in the name of the beam shape: bulb tee.

Please be advised that the correct coding for a New England Bulb Tee design type is “Girder”. The proper coding for Item 43 would be either 502 or 602.

BBC/bbc

10.5 SHIELDING REPORTING AND CODING ISSUED 2/16/11

**THE COMMONWEALTH OF MASSACHUSETTS
DEPARTMENT OF TRANSPORTATION – HIGHWAY DIVISION
INTEROFFICE MEMORANDUM**

TO: Bridge Inspection Staff

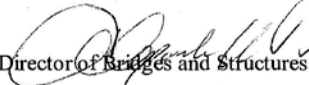
THRU: Alexander K. Bardow, P.E., Director of Bridges and Structures 

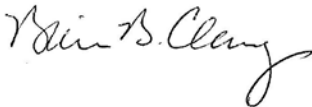
FROM: Brian B. Clang, P.E., Bridge Inspection Engineer 

DATE: February 16, 2011

RE: Shielding Reporting and Coding

It has become more common for District Bridge Maintenance to install shielding on the underside of bridges over roadways where there is potential for spalling concrete falling onto traveled ways below. I feel that the shielding should be identified on our inspection reports: type, location and overall condition.

For the time being please create a new Deck sub element no. **58.14 - Shielding** on page 1 of your reports. Indicate a numerical condition rating and deficiency coding on page 1 as appropriate and provide a written description in the text portion of the report (even if the condition is better than fair). The written description should at a minimum indicate the type of shielding used (material) and the limits. The main shielding materials in use are as follows:

Timber
Expanded Metal
Fabric Wrap

It is hoped that consistent reporting will allow accurate searches for shielded bridges when necessary. Please be sure to use one of the underlined words when describing the shielding material, allowing us to search for the key words. If other materials are in use indicate the materials as appropriate. Shortly we hope to have sub element 58.14 added into the 4D reports.

Thank you for your cooperation.

BBC/bbc

10.6 CODING CLARIFICATION FOR PARAPETS AND BRIDGE RAILING ISSUED 11/12/13

**MASSACHUSETTS DEPARTMENT OF TRANSPORTATION
HIGHWAY DIVISION
INTEROFFICE MEMORANDUM**

TO: Bridge Inspection Staff

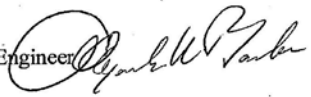
THRU: Alexander K. Bardow, P.E., State Bridge Engineer 

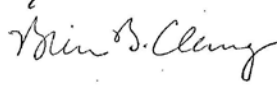
FROM: Brian B. Clang, P.E., Bridge Inspection Engineer 

DATE: November 12, 2013

RE: Coding Clarification for Parapets and Bridge Railing

There has been a bit of inconsistency with inspection reporting for parapets and bridge railing. The confusion may exist because popular bridge inspection references have historically used the terms interchangeably. For instance the FHWA's Bridge Inspector's Training Manual 90, under Section 7.7.1 Bridge Barriers list examples of bridge railings that include solid concrete parapets and steel and aluminum railings. It also presents Figure 7-15 which shows a pigeonhole parapet as an example of a bridge railing.

A general rule of thumb is offered for determining if any given bridge barrier is a parapet or a railing: "If you can pass your arm through the barrier system than it is a railing. If you cannot, then it is a parapet." For example, the S3-TL4 (three rails with or without pickets) railing is obviously a railing and a CF-PL2 (solid concrete "Jersey" barrier) is a parapet. The CT-TL2 (concrete "Texas" rail) would be a railing because of the openings.

There are many situations where we do have both parapets and railings, such as a single steel rail mounted on a low concrete parapet. Another example would be when a railing is mounted on a concrete base. In such cases we would prefer that the rail be coded as a railing and the base be coded as a parapet.

Attached is a series of sketches of some of the more typical bridge rail systems in use in Massachusetts with our recommended coding of components.

There are definitely bridge rail systems that do not fit the above descriptions. For such cases use your best judgment based upon the guidelines offered in the attachment.

Thank you for working with me to standardize our NBIS coding.

BBC/bbc

Attachment

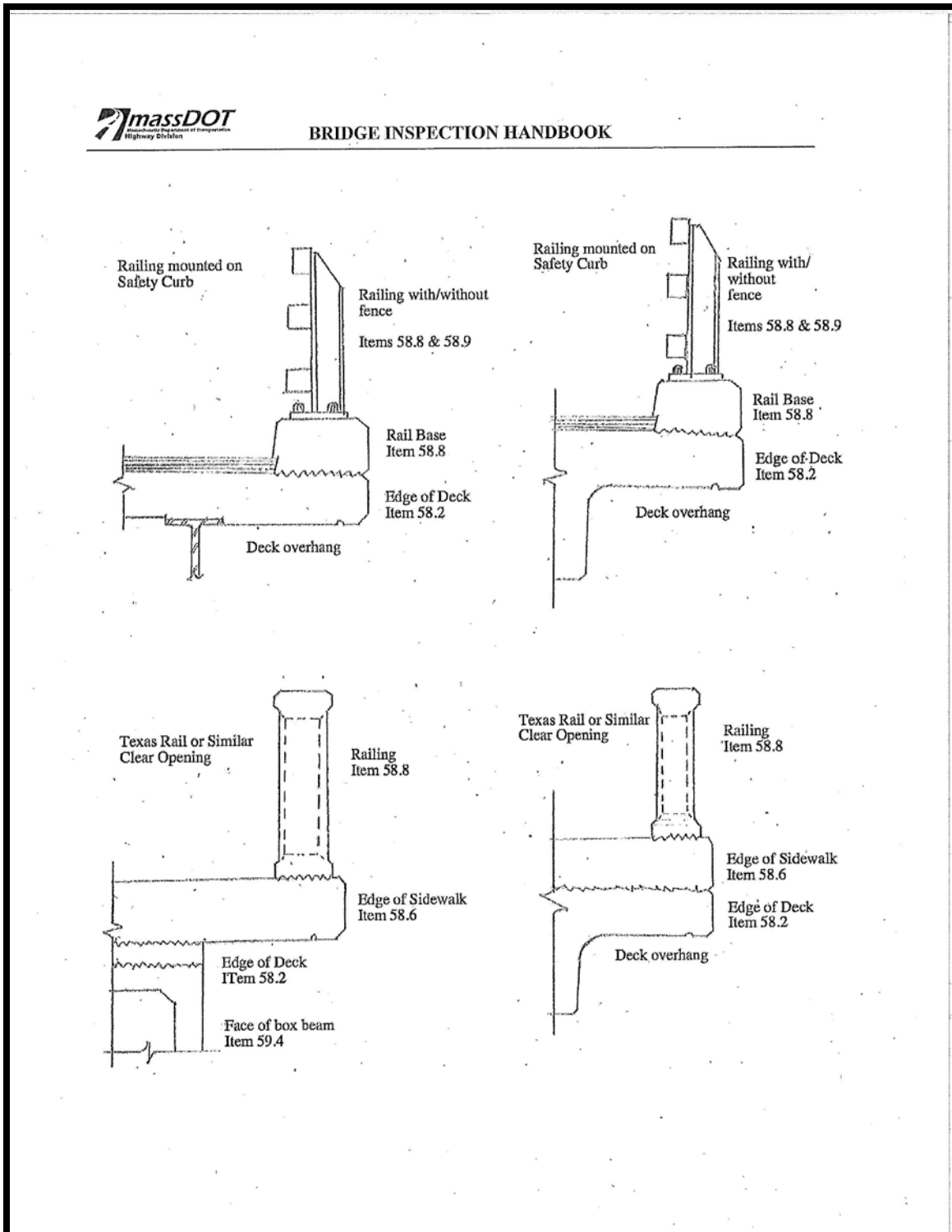

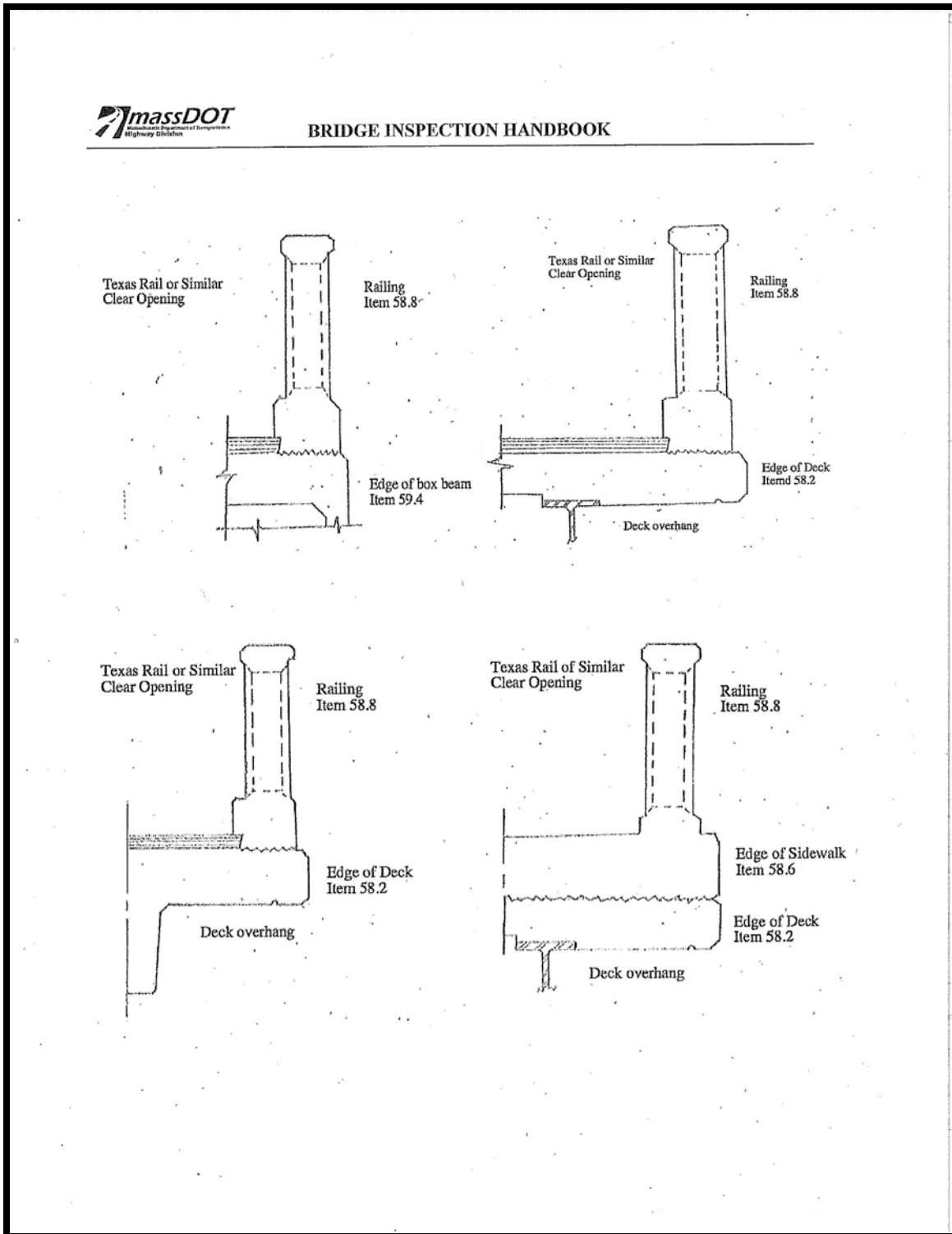

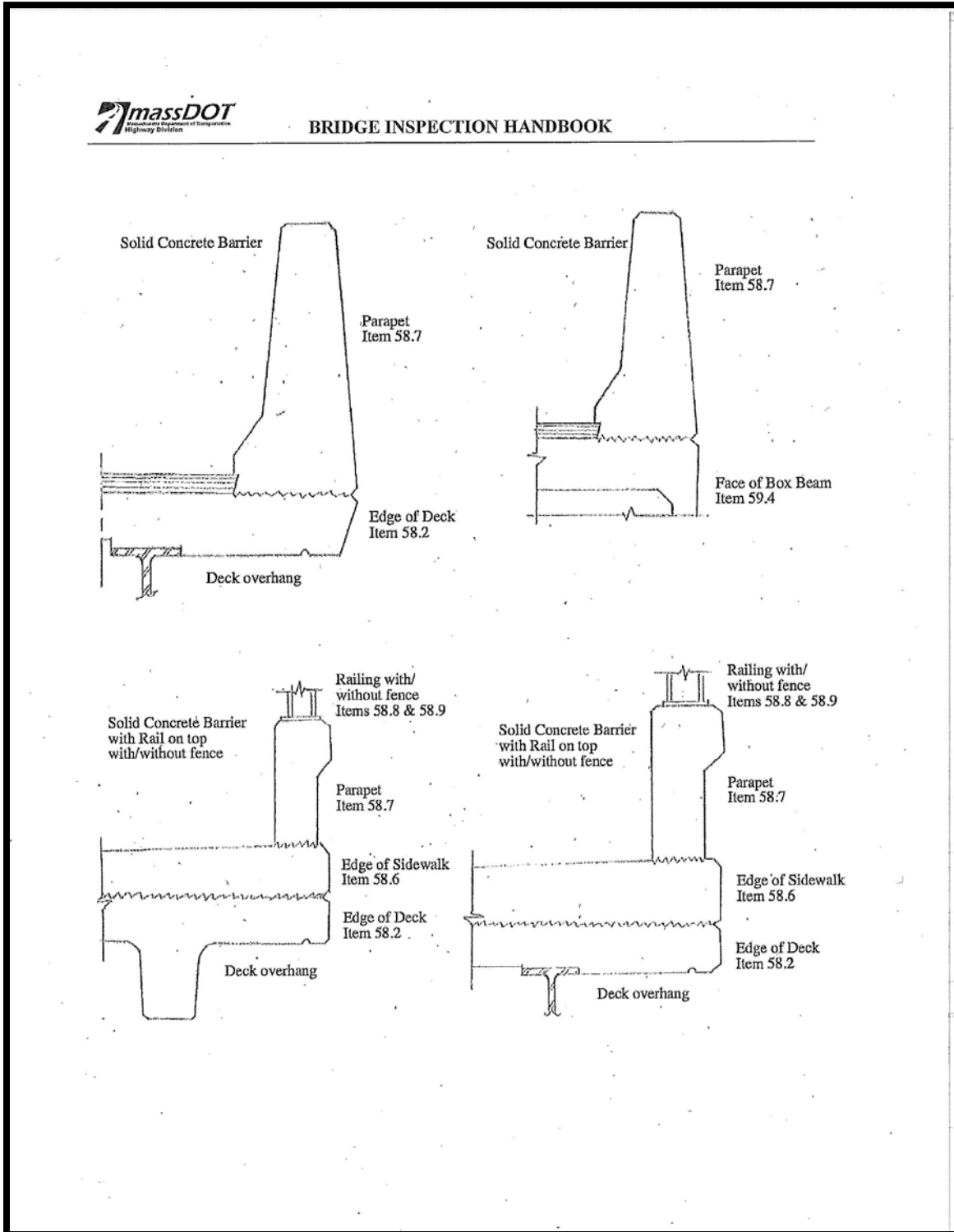

Attachment 10-6: Coding Supplement for Parapets and Bridge Railing dated 11/12/13, Page 4 of 5

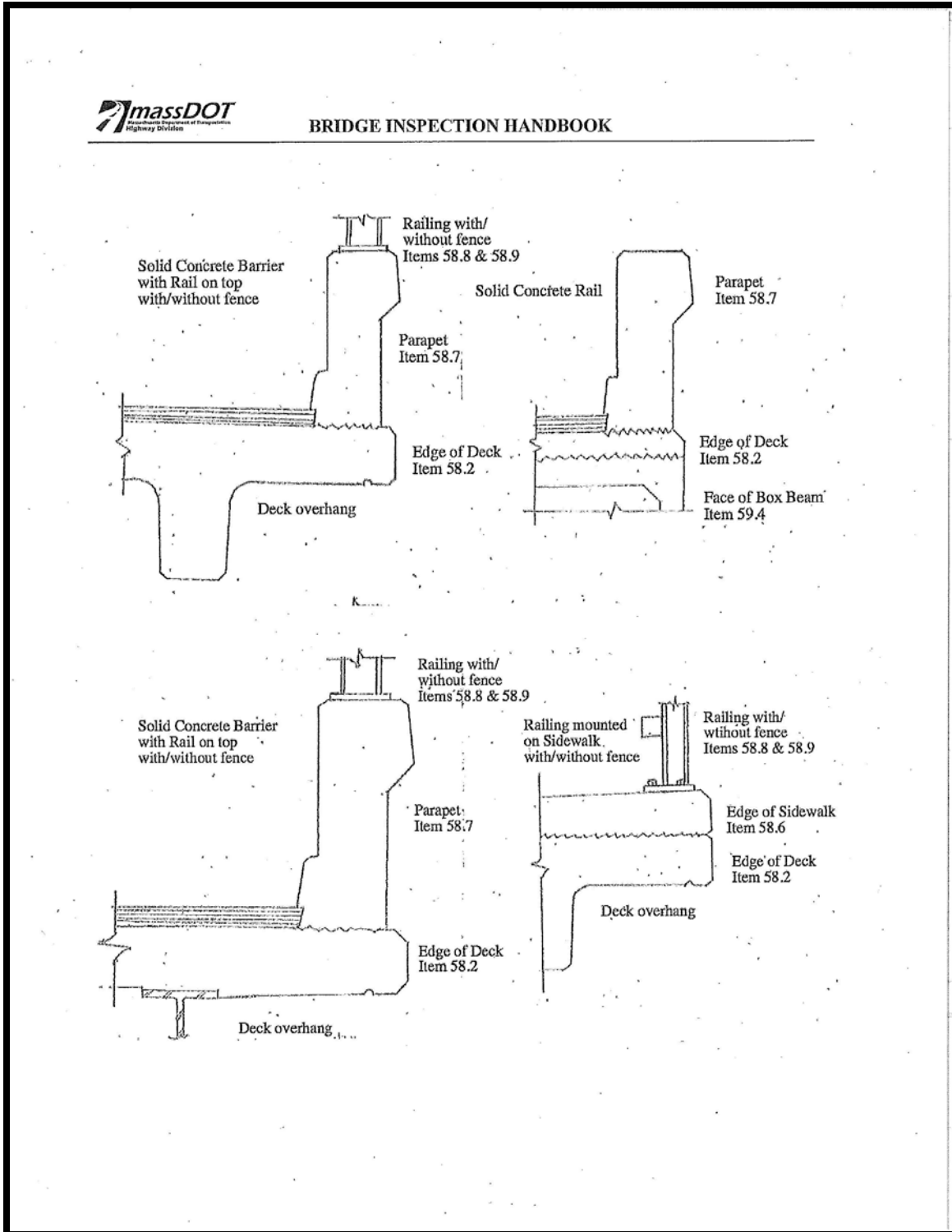



Attachment 10-6: Coding Supplement for Parapets and Bridge Railing dated 11/12/13, Page 5 of 5

10.7 INSPECT WHAT YOU CAN ...WHEN IT IS DUE ISSUED 11/17/14

MASSACHUSETTS DEPARTMENT OF TRANSPORTATION
HIGHWAY DIVISION
INTEROFFICE MEMORANDUM

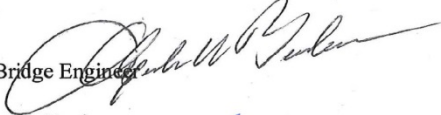
TO: Bridge Inspection Staff

THRU: Alexander K. Bardow, P.E., State Bridge Engineer 

FROM: Brian B. Clang, P.E., Bridge Inspection Engineer 

DATE: November 17, 2014

RE: Inspect What You Can... When It Is Due!

Often access to bridges for our safety inspections is delayed or interrupted. Typical examples include Railroad right-of-way access permit delays and active construction operations/phasing. Other reasons could include high water flows or heavy snow accumulation. I would like to remind all that our safety inspections should be completed when they are due as per NBIS and MassDOT criteria.

If any portion of the structure can still be accessed during the month that the NBIS inspection is due then proceed with the inspection. Whatever cannot be inspected during that month will have to be put off until access is possible or is granted. An inspection report should be prepared for the elements inspected. A comment should be included in the general comments section of the report describing the areas of the bridge that were not inspected at this time and the reason for the delay. The inspection report should carry the first date that the field inspection was started.

If the follow up inspection is within the next month then the inspectors should hold off completing the report until all of the condition information is obtained. The completed inspection report should carry the first date that the field inspection was started, not the follow up date.

If the follow up inspection is expected to be later than the next month then the TL should complete the inspection report as is. Items 58, 59, 60 and 62 should be coded for the conditions noted during the first inspection. The Team Leader should return to the bridge when access is available and complete an "Other" inspection report for the areas of the bridge not accessed previously. When assigning condition ratings for Items 58, 59, 60 or 62 as applicable at the completion of the Other Inspection the team should consider the entire bridge, not just the areas inspected during the follow-up inspection.

Thank you for working with me to ensure timely safety inspections and compliance with NBIS and MassDOT inspection frequency criteria.

10.8 BRI: DEFINITIONS AND METHOD OF MEASURING LENGTH OF SPAN
ISSUED 4/6/16

**MASSACHUSETTS DEPARTMENT OF TRANSPORTATION
HIGHWAY DIVISION
INTEROFFICE MEMORANDUM**

TO: Bridge Inspection Staff

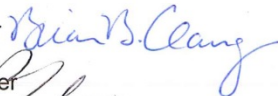
THRU: Brian B. Clang, P.E., Bridge Inspection Engineer 

FROM: Alexander K. Bardow, P.E., State Bridge Engineer 

DATE: April 6, 2016

RE: BRI: Definitions and Method of Measuring Length of Span

As part of MassDOT's BRI inspection program and in anticipation of the Municipal Bridge Program, I have put together guidance on how to determine if a bridge is a BRI. The information contained within this memorandum gives a definition of BRI, provides relevant references, and provides guidance on how and where to measure the span length to determine if a structure is a BRI, NBI or not. The intent is to make sure that everybody is going about determining BRI's consistently.

Since this guidance is going out after the start of our BRI inspections, those bridges that have been inspected and are currently in the inventory as BRIs would have to be re-measured in compliance with these guidelines.

BRI: Definitions and Method of Measuring Length of Span

What is a BRI?

A "BRI" is a highway bridge structure that meets the Massachusetts General Laws (MGL) definition of a bridge but not the federal definition of a bridge. MGL recognize structures having a span greater than 10 feet as bridges, but federal regulations define a bridge as a structure having a span greater than 20 feet. MassDOT uses the category code of "BRI" in order to identify and track MGL definition bridges in its inventory.

References

MGL Chapter 85 Section 35 (relevant provisions):

No bridge on a public highway having a span in excess of ten feet, ... , shall be constructed or reconstructed by any county or town except in accordance with plans and specifications therefor approved by the department. Said department shall approve or alter to meet its approval all such plans submitted to it and shall determine the maximum load which any such bridge may safely carry...

Federal regulations, 23CFR Part 650 Subpart C, National Bridge Inspection Standards (NBIS):

Bridge: A structure including supports erected over a depression or an obstruction, such as water, highway, or railway, and having a track or passageway for carrying traffic or other moving loads, and having an opening measured along the center of the roadway of more than 20 feet between undercopings of abutments or spring lines of arches, or extreme ends of openings for multiple boxes; it may also include multiple pipes, where the clear distance between openings is less than half of the smaller contiguous opening.

How is a structure determined to be a BRI?

MGL Ch 85 Sec 35 only requires that a bridge have a span in excess of 10 feet. The engineering definition of the term “span” refers to the distance between adjacent centerlines of bearings. However, MGL Ch 85 Sec 35 is primarily concerned with authorizing MassDOT to approve bridge plans prepared by municipalities and to determine a bridge’s safe load carrying capacity. As a result, it provides no guidance on where to measure the span, nor does it provide guidance on how to measure the span for structures that do not have defined centerlines of bearings, such as culverts, arch bridges or in the case of pipes that perform the function of a bridge. To address these questions, MassDOT defaults to the NBIS definition requirements.

Therefore, a BRI is determined as follows:

1. It must be on and carry a public highway.
2. All span measurements are taken along the centerline of the roadway.
3. For bridges that have defined centerlines of bearings, measure the total distance from the centerline of bearings on one abutment to the centerline of bearings on the other abutment. (See Figure 1)
4. For bridges that do not have defined centerlines of bearings, such as arches, culverts and those bridges where the ends of the beams are encased so that there is no centerline of bearings, measure the clear opening between the breastwalls of abutments, the spring lines of arches, or extreme ends of openings for multiple boxes. (See Figures 2a, 2b, 2c)
5. For bridges that consist of large size pipes, measure the maximum diameter of the pipe, or, in the case of multiple pipes, the maximum total distance across all pipes provided that the clear distance between pipes is less than half the diameter of the smaller contiguous pipe. (See Figure 3)

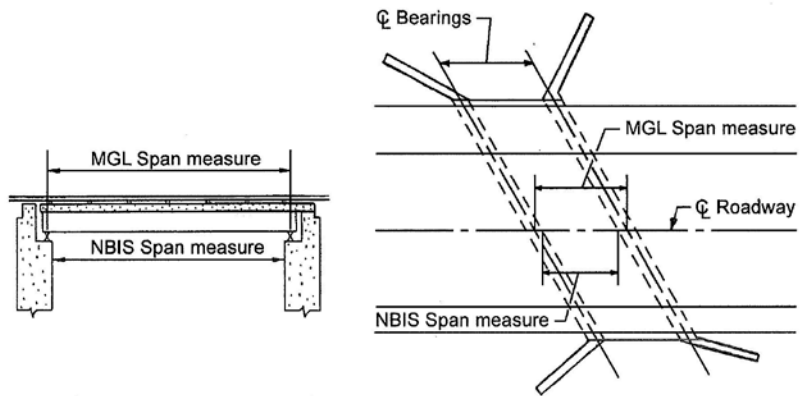

NOTE: Since the MGL Span and the NBIS Span measures are different, the MGL Span measure may exceed 20 feet while the NBIS Span measure may be less than 20 feet. In this instance, the bridge would still be considered a BRI because it does not meet federal definition of a bridge.

Figure 1: Bridges with Defined Centerlines of Bearings

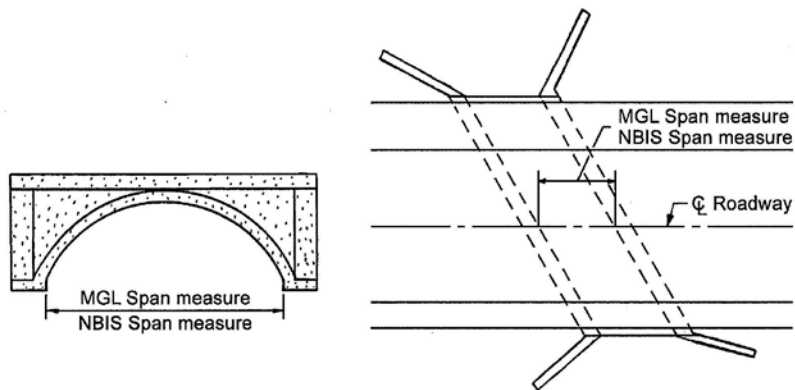
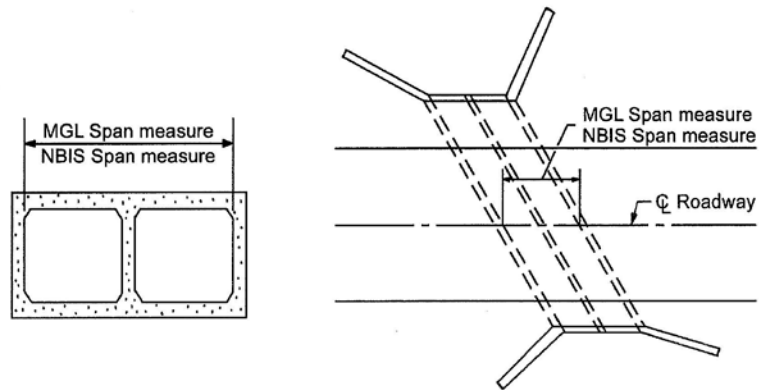

Figure 2a: Arch Type Bridges



NOTE: This also includes three sided frame type culverts.

Figure 2b: Culvert Type Bridges

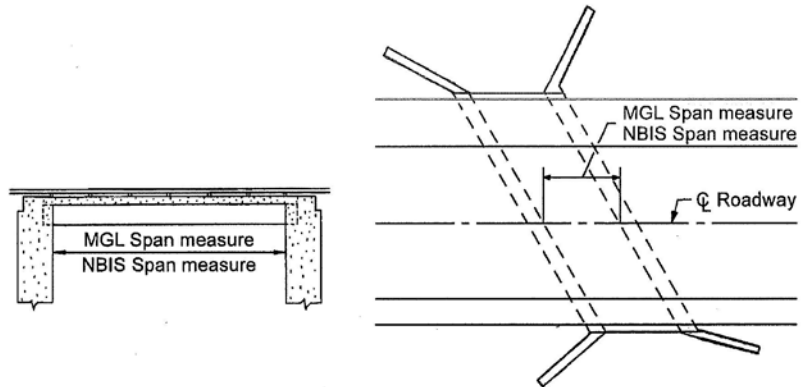
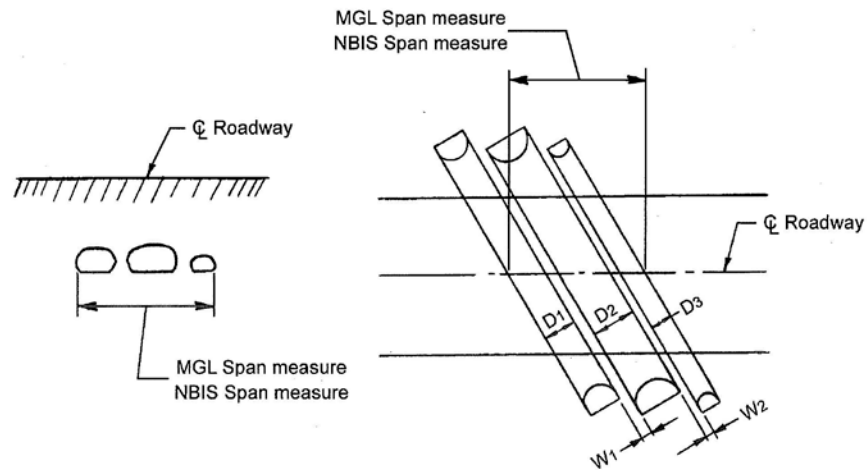

Figure 2c: Bridges without Defined Centerlines of Bearings



NOTE: In order for the MGL Span measure to be taken as shown above, W1 must be less than $\frac{1}{2}$ D1 and $\frac{1}{2}$ D2 and W2 must be less than $\frac{1}{2}$ D2 and $\frac{1}{2}$ D3. If, for instance, W2 were greater than $\frac{1}{2}$ D3, then the span measure would only include D1, W1, and D2. This method of measure also applies to multiple opening Clapper type structures, where a stone slab sits on thick piers.

Figure 3: Multiple Pipe Culvert Structures

AKB/akb

10.9 NBIS DATA UPLOADING PROCESS CHANGE ISSUED 9/25/17

MASSACHUSETTS DEPARTMENT OF TRANSPORTATION
HIGHWAY DIVISION
INTEROFFICE MEMORANDUM

TO: Bridge Inspection Personnel and Consultants

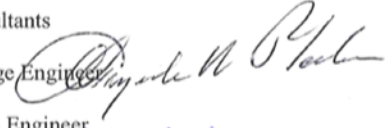
THRU: Alexander K. Bardow, P.E., State Bridge Engineer 

FROM: Brian B. Clang, P.E., Bridge Inspection Engineer 

DATE: September 25, 2017

RE: NBIS Data Uploading Process Change

In order to assure compliance with the FHWA National Bridge Inspection Program metric to have inspection data uploaded into 4D within 90 days of the inspection, we will be instituting a process change. Beginning September 29, 2017 pertinent NBI data will be automatically uploaded into 4D when an inspection report is marked "ready for review". This process change is necessary so that all inspection data, statewide, is uploaded into the bridge inspection database within the required time frame.

Note that only the Team Leader for the inspection or his or her DBIE will be able to check the report ready for review. Other inspectors assisting with the preparation of the report, such as Team Members will not be able to complete this step.

The Team Leader will be presented with a Confirmation dialog box containing a reminder that the action will update the SI&A and list the items to be updated. For example a Routine report will update items 41, 58, 59, 60, 61, 36A, 36B, 36C, 36D, and 90. The automatic upload will be completed for Routine, Routine Arch, Culvert, Fracture Critical, Special Member, Underwater and Underwater Low Clearance reports.

As you can surely appreciate, it is very important that the report is fully completed, that all coding data is complete and accurate when the Team Leader marks it ready for review.

The DBIE will still be able to make changes to the data if necessary following his or her review. When the DBIE completes the review of the report and approves it in 4D, any changed data from the original upload will be automatically revised as necessary.

Thank you for working with me to ensure compliance with NBIS criteria.

BBC/bbc