

CDL Skills Test

# PRE-TRIP Inspection

Engine Compartment +1 Axle

Side and Back of Truck +1 Axle

Connections and Trailer +1 Axle

External Light Check

In-Cab with Brake Check

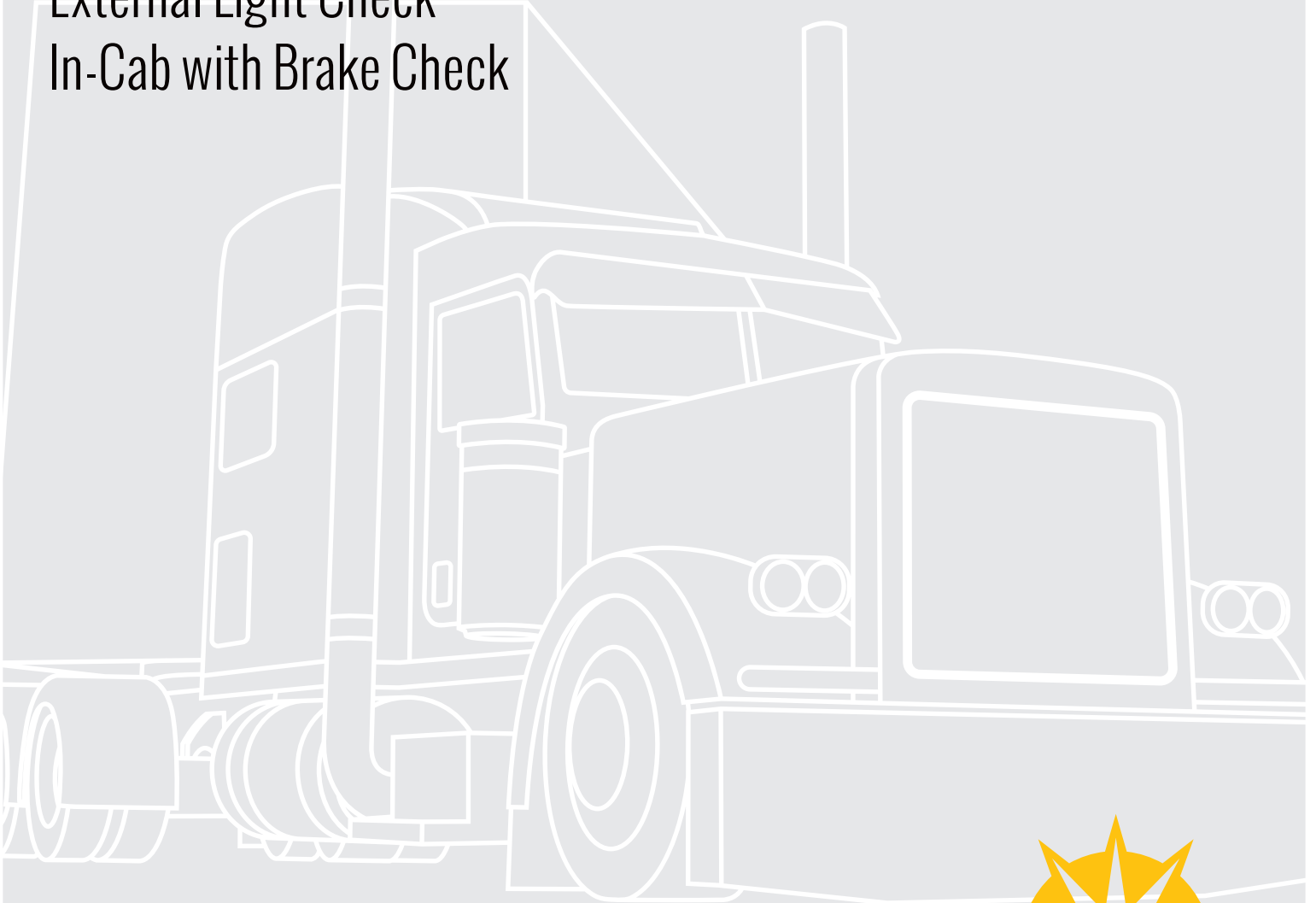

7505 Dahlia St. Commerce City, CO 80022 303-227-7841

**CDL COLLEGE**

# Engine Compartment + 1 Axle

**ABC**–Abrasions, Bruises, Cuts    **BBC**–Bent, Broken, Cracked    **Not Leaking**–air and liquid-holding parts  
**Wear Gloves**–touch every part you inspect    **Order**–inspect from the top down and from the center out

Make It Easy: **3 Fluids, 3 Components, Belts and Hoses; Axle Last**

## Leaks, Leans, Lights (3 L's) 3 Fluids

Stand in front of the truck. Ensure there are no **LEAKS** underneath the engine compartment.

Make sure the truck isn't **LEANING** to one side which could indicate a suspension problem or low tire pressure.

Lastly, verify that the **LIGHTS** on the front of the truck are the proper color, securely mounted, not cracked or dirty, and have no moisture inside.

*Check front of truck for any other damage. Tell the tester that you'll note all damage on your DVIR (Driver Vehicle Inspection Report).*

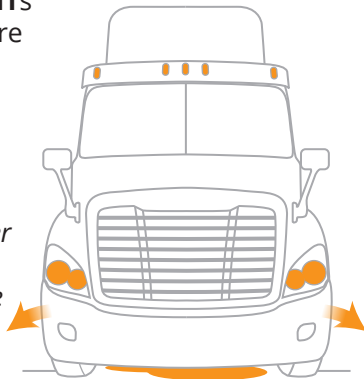

**Coolant:** verify proper level, not leaking, securely mounted, not BBC; check the **hoses** for splits or cuts and ensure they are securely mounted.

**Oil:** indicate where the dipstick is located and that the oil is at the proper level.

**Power Steering fluid:** not leaking, proper level, securely mounted, not BBC; check the **hoses** for splits or cuts and ensure they are securely mounted.



## 3 Components

**Alternator:** not BBC and must be securely mounted; wires are securely mounted and not frayed. Belt or gear driven, belt has no more than 1/2" to 3/4" of play, no splits or cuts.

**Water Pump:** (follow large pipe from bottom of radiator to find w.p.) securely mounted, not BBC; not leaking, belt or gear driven, belt has no more than 1/2" to 3/4" inch of play and has no splits or cuts.

**Air Compressor:** not BBC and must be securely mounted; no audible leaks and belt or gear driven. If belt-driven, belt has no more than 1/2" to 3/4" inch of play and has no splits or cuts.

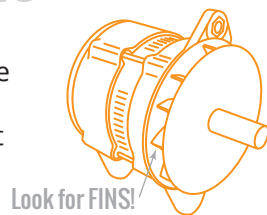

Look for FINS!

*Not all water pumps look the same. Follow the large hose from the bottom of the radiator.*

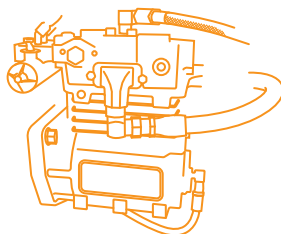

## Belts and Hoses

After properly inspecting the **power steering hose** and the **coolant hose**, tell the tester that you would inspect all remaining hoses the same way.

After properly inspecting the **alternator belt**, tell the tester that you will inspect all remaining belts the same way.

# Engine Compartment cont'd

**ABC**–Abrasions, Bruises, Cuts    **BBC**–Bent, Broken, Cracked    **Not Leaking**–air and liquid-holding parts  
**Wear Gloves**–touch every part you inspect    **Order**–inspect from the top down and from the center out

Make It Easy: **3 Fluids, 3 Components, Belts and Hoses; Axle Last**

## Steering

**Power Steering Box:** not BBC, no leaks, securely mounted, all hardware present, none missing; **hose** no ABC's, securely mounted.

**Pitman Arm:** not BBC, securely mounted, all hardware in place none missing. Castle nuts not BBC, cotter pins in place.

**Drag Link:** not BBC, securely mounted, castle nuts not BBC, cotter pin in place. Bushings: no ABC's, properly greased.

**Upper and Lower Control Arms and Tie Rod:** not BBC, securely mounted, all hardware present.

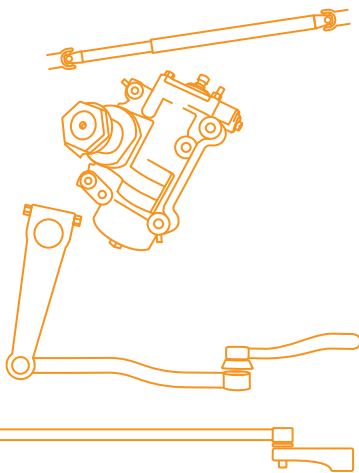

## Suspension

**Spring mounts:** spring mounts and hardware are not BBC, securely mounted to frame.

**Leaf Springs:** not BBC, securely mounted, no scissoring.

**U-bolts:** not BBC, securely mounted, no shiny metal, nuts in place not BBC.

**Shock absorber:** not BBC, securely mounted, no leaks, rubber bushings no ABC's.

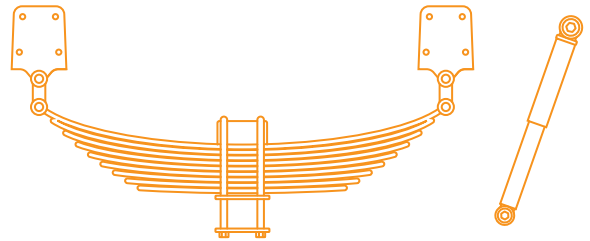

## Brakes

**Brake Hose:** hose to brakes chamber not split or cut, no audible leaks, securely mounted.

**Brake Chamber:** not BBC, securely mounted, no audible leaks, all hardware in place none missing.

**Slack Adjuster:** not BBC securely mounted, no missing pins, pushrod has no more than 1" of play and is at a 90° angle to brake chamber.

**Brake Drum:** not BBC, securely mounted, no blueing from heat.

**Brake Pads:** not BBC, securely mounted, no less than 1/4" of pad.

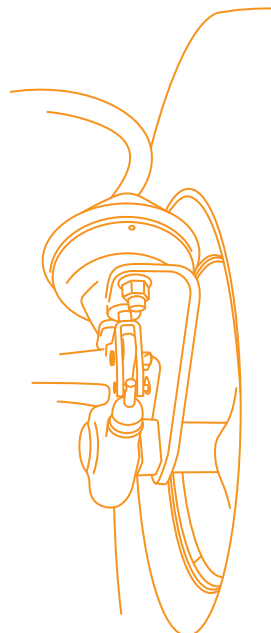

## Wheel/Tire

**Wheel inside:** not BBC, securely mounted, no illegal welds, bead is undamaged.

**Tire:** sidewalls have no ABC's; tread depth is 4/32" min., evenly worn, check inflation w/ air gauge (do not kick tires); no re-treads on steers.

**Wheel outside:** not BBC, securely mounted, no illegal welds, bead is undamaged.

**Valve Stem:** not BBC, securely mounted, metal cap.

**Lug Nuts:** not BBC, securely mounted, no rust trails or spidering, none missing.

**Hub Seal:** not BBC, securely mounted, not leaking, hardware in place not loose; explain how to check oil level.



# Side and Back of Truck + 1 Axle

**ABC**–Abrasions, Bruises, Cuts    **BBC**–Bent, Broken, Cracked    **Not Leaking**–air and liquid-holding parts  
**Wear Gloves**–touch every part you inspect    **Order**–inspect from the top down and from the center out

Make It Easy: **Inspect from Top to Bottom, Front to Rear; Axle Last**

## Side and Back of Truck

**Mirror:** securely mounted, not BBC, all hardware in place none missing.

**Door:** securely mounted, not BBC, opens and closes, hinges securely mounted, not BBC, rubber seal securely mounted, no ABC's; glass not BBC.

**Steps:** securely mounted, not BBC, hold my weight, not excessively dirty.

**Fuel tank:** securely mounted, not BBC, not leaking, cap is tight.

**Exhaust:** securely mounted, not BBC, all hardware present, no evidence of leaks (exterior soot).

**Cat Walk and Steps:** securely mounted, not BBC, not excessively dirty; steps securely mounted, not BBC, free of debris.

**Frame:** securely mounted, not BBC, no illegal welds.

**Drive Shaft:** securely mounted, not BBC, U-joints securely mounted, not BBC, no foreign objects.

**Rear lights:** proper color, securely mounted, not cracked or dirty, no moisture inside the lense.

**Mud Flap:** securely mounted, not BBC, all hardware in place none missing; mud flap not split or cut, 6" from tire, 8" from ground.

**Space:** enough space between rear of truck and landing gear for turns.

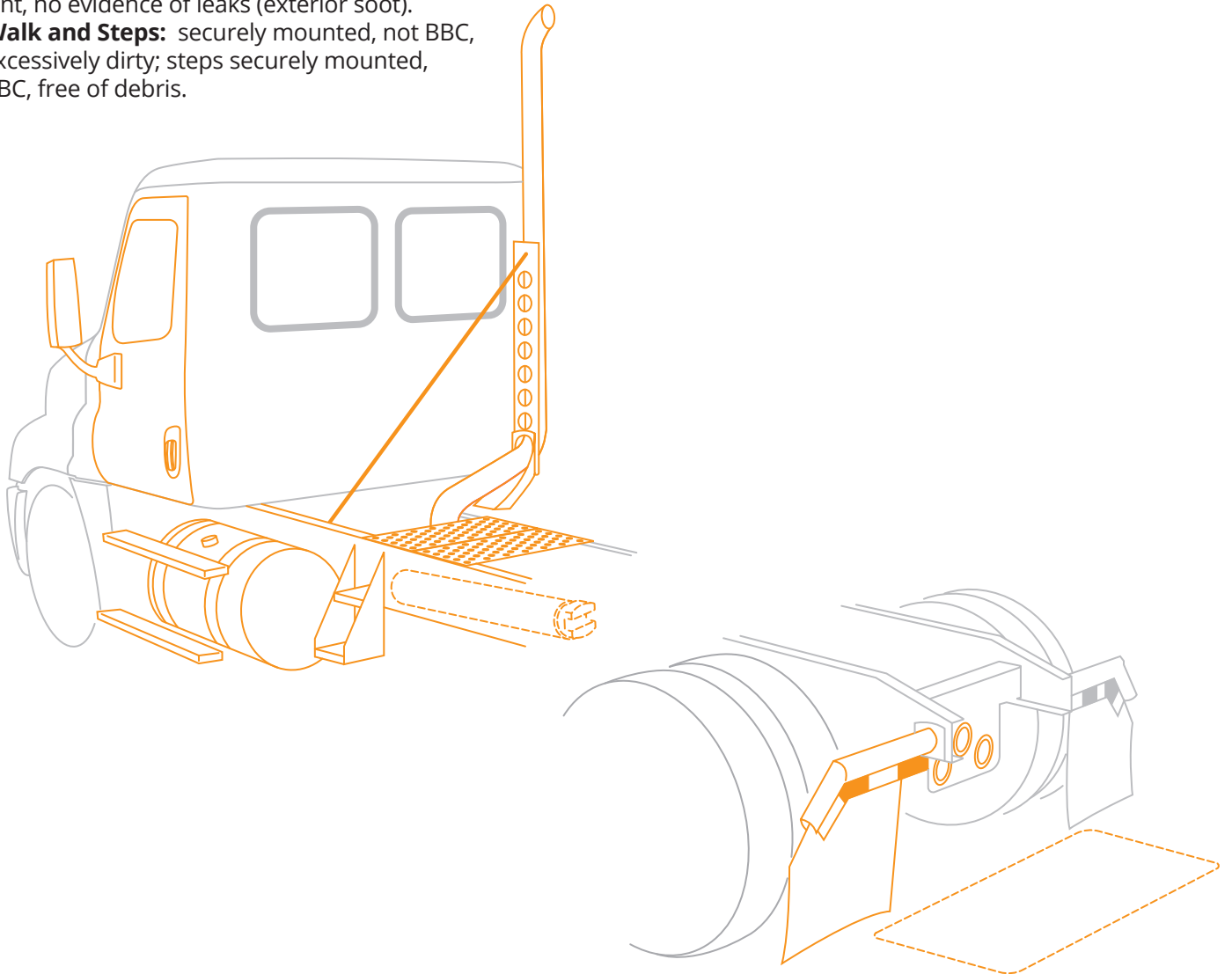

# Side and Back of Truck cont'd

**ABC**–Abrasions, Bruises, Cuts    **BBC**–Bent, Broken, Cracked    **Not Leaking**–air and liquid-holding parts  
**Wear Gloves**–touch every part you inspect    **Order**–inspect from the top down and from the center out

Make It Easy: **Inspect from Top to Bottom, Front to Rear; Axle Last**

## Axle

**Note**–not all axles are the same. You must determine which suspension components are present and inspect those components.

**Axle:** suspension, brakes, wheels, tires.

**Spring mounts:** spring mounts and hardware are not BBC, securely mounted to frame.

**Leaf Springs:** not BBC, securely mounted, no scissoring. (No leaf springs? Inspect the **torque rod** or **swing arm**: securely mounted and no damage).

**Torque Arm:** securely mounted and no damage.

**U-bolts:** not BBC, securely mounted, no shiny metal, nuts in place not BBC.

**Shock Absorber:** not BBC, securely mounted, no leaks, rubber bushings no ABC's.

**Air Bags:** the bags not split or cut, no audible leaks, mounts are securely mounted, not BBC, all hardware in place none missing.

**Brakes:** hose to brakes chamber not split or cut, no audible leaks, securely mounted.

**Brake Chamber:** not BBC, securely mounted, no audible leaks, all hardware in place none missing.

**Slack Adjuster:** not BBC and securely mounted, no missing pins, pushrod has no more than 1" of play and is at a 90° angle to brake chamber.

**Brake Drum:** not BBC, securely mounted, no blueing from heat.

**Brake Pads:** not BBC, securely mounted, no less than 1/4" of pad.

**Wheel:** not BBC, securely mounted, no illegal welds, bead is undamaged.

**Tires:** sidewalls have no ABC's; tread depth is 2/32" min., evenly worn, check inflation w/ air gauge (do not kick tires); can be re-tread; no foreign objects between tires, no gap between wheels.

**Wheel outside:** not BBC, securely mounted, no illegal welds, bead is undamaged.

**Valve Stem:** not BBC, securely mounted, metal cap.

**Lug Nuts:** not BBC, securely mounted, no rust trails or spidering, none missing.

**Hub Seal:** not BBC, securely mounted, not leaking, hardware in place not loose; explain how to check oil level with finger.

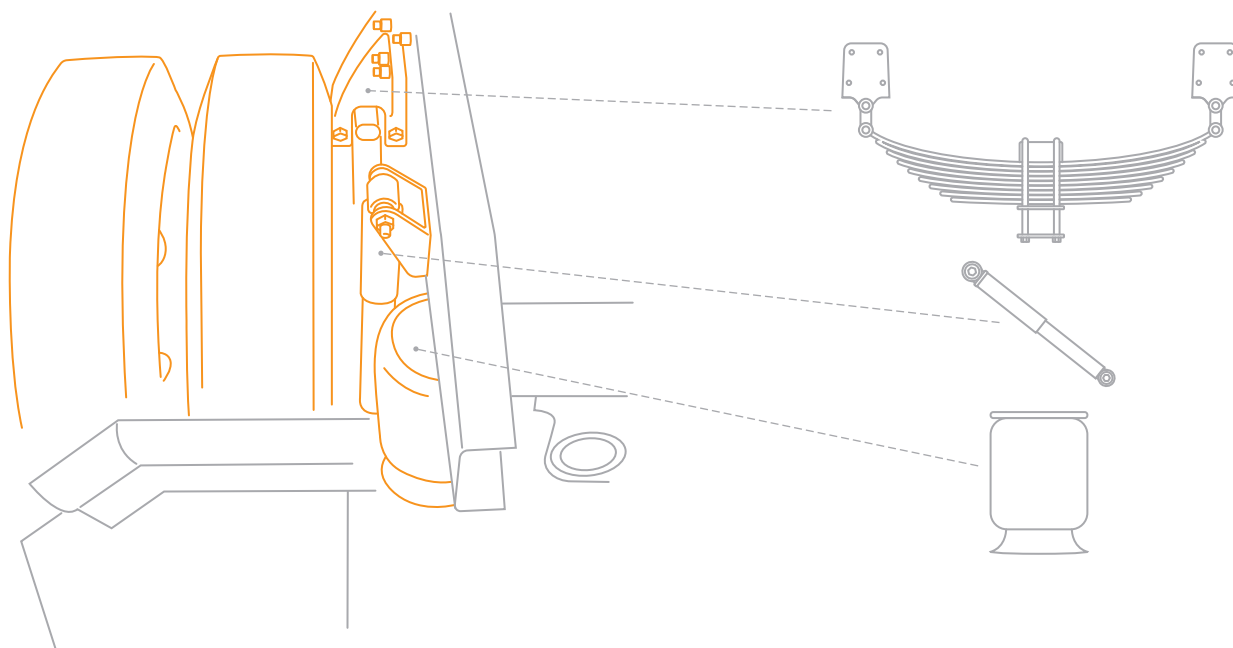

# Connections and Trailer + 1 Axle

**ABC**–Abrasions, Bruises, Cuts    **BBC**–Bent, Broken, Cracked    **Not Leaking**–air and liquid-holding parts  
**Wear Gloves**–touch every part you inspect    **Order**–inspect from the top down and from the center out

Make It Easy: **Connections–Start at Rear of Cab, end with Kingpin**

## Connections

**Air/Electrical Lines:** ensure **air lines** are securely mounted at BOTH ends. All hardware is present, nothing is BBC. Lines have no ABC's. No audible leaks. Glad hands are locked in place and undamaged.

Ensure **electrical line** is securely mounted at BOTH ends. All hardware is present, nothing is BBC. Lines have no ABC's. Safety latches are in place, not BBC. Lines are not tangled or dragging on catwalk.

### Fifth Wheel Assembly

**Apron:** securely mounted, not BBC. No gap btwn apron and skid plate.

**Skid Plate:** properly greased, securely mounted, not BBC. All hardware present, none missing.

**Pivot Pin:** is securely mounted, not BBC, cotter pin is in place.

**Platform:** is securely mounted to frame, not BBC, all hardware is present, not BBC.

**Release Handle:** is securely mounted, not BBC, in locked position.

**Kingpin and Locking Jaws:** both are securely mounted and not BBC. Locking jaws are secured around kingpin, both are properly greased.

**(SLIDING FIFTH WHEEL:** all hardware is present; air line is securely mounted, no audible leaks, no ABC's)

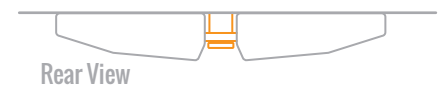
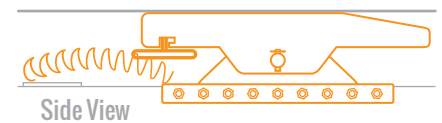
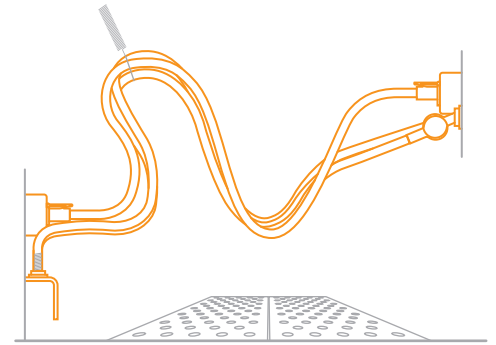

## Trailer

### TRAILER Inspection:

**Front of Trailer:** clearance lights proper color, securely mounted, not cracked or dirty, no moisture inside lense. Header board not BBC, all hardware present.

**Side of Trailer:** not BBC, no holes, all rivets in place. **DOT tape** is securely mounted, not dirty, covers at least 50% of the side. **Frame** is not BBC, securely mounted. **Cross members** are securely mounted, not BBC, none missing; **floor** has no holes. **Landing gear** is raised, not BBC, securely mounted, no missing hardware; **handle** not BBC, securely mounted, and operational; **light** securely mounted, proper color, not cracked or dirty, gasket has no ABC's; **hoses** underneath are securely mounted, no ABC's, not dragging on ground; **tandem slide** not BBC, securely mounted, pins locked in place, not BBC; **release arm** not BBC, securely mounted and in place; **mud flaps** securely mounted, not BBC, and long enough; **ABS light** not BBC, not dirty.

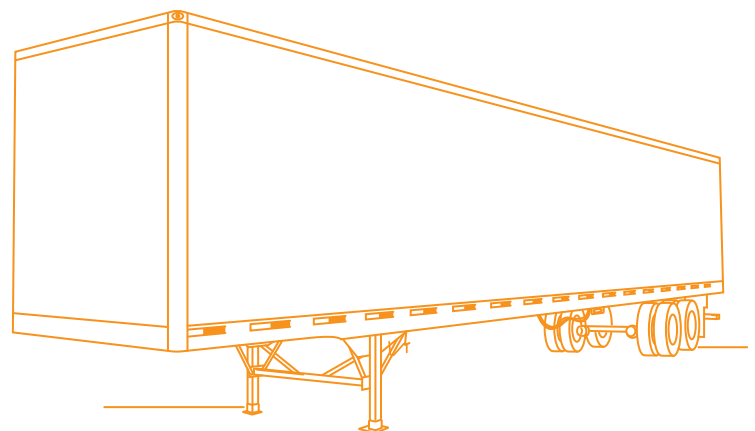

# Connections and Trailer cont'd

**ABC**–Abrasions, Bruises, Cuts    **BBC**–Bent, Broken, Cracked    **Not Leaking**–air and liquid-holding parts  
**Wear Gloves**–touch every part you inspect    **Order**–inspect from the top down and from the center out

Make It Easy: **Trailer–Inspect from Top to Bottom, Front to Rear; Axle Last**

## Trailer, cont'd

**Back of Trailer:** clearance lights are proper color, not cracked or dirty, no moisture inside lense; **hinges** are securely mounted, not BBC; **doors** not BBC, no holes; **door seal** intact, no damage, securely mounted; **door handles and rods** not BBC, securely mounted, operational; **lights** are proper color, securely mounted, not cracked or dirty, no moisture inside lense; **DOT tape** is securely mounted, not dirty, covers 100% of rear; **bumper** is securely mounted, not BBC.

## Axle

**Note**–not all axles are the same. You must determine which suspension components are present and inspect those components.

**Axle:** suspension, brakes, wheels, tires.

**Spring mounts:** spring mounts and hardware are not BBC, securely mounted to frame.

**Leaf Springs:** not BBC, securely mounted, no scissoring. (No leaf springs? Inspect the **torque rod** or **swing arm**: securely mounted and no damage).

**U-bolts:** not BBC, securely mounted, no shiny metal, nuts in place not BBC.

**Shock Absorber:** not BBC, securely mounted, no leaks, rubber bushings no ABC's.

**Air Bags:** the bags not split or cut, no audible leaks, mounts are securely mounted, not BBC, all hardware in place none missing.

**Brakes:** hose to brakes chamber not split or cut, no audible leaks, securely mounted.

**Brake Chamber:** not BBC, securely mounted, no audible leaks, all hardware in place none missing.

**Slack Adjuster:** not BBC and securely mounted, no missing pins, pushrod has no more than 1" of play and is at a 90° angle to brake chamber.

**Brake Drum:** not BBC, securely mounted, no blueing from heat.

**Brake Pads:** not BBC, securely mounted, no less than 1/4" of pad.

**Wheel:** not BBC, securely mounted, no illegal welds, bead is undamaged.

**Tires:** sidewalls have no ABC's; tread depth is 2/32" min., evenly worn, check inflation w/ air gauge (do not kick tires); can be re-tread;

no foreign objects between tires, no gap between wheels.

**Wheel outside:** not BBC, securely mounted, no illegal welds, bead is undamaged.

**Valve Stem:** not BBC, securely mounted, metal cap.

**Lug Nuts:** not BBC, securely mounted, no rust trails or spidering, none missing.

**Hub Seal:** not BBC, securely mounted, not leaking, hardware in place not loose; explain how to check oil level with finger.

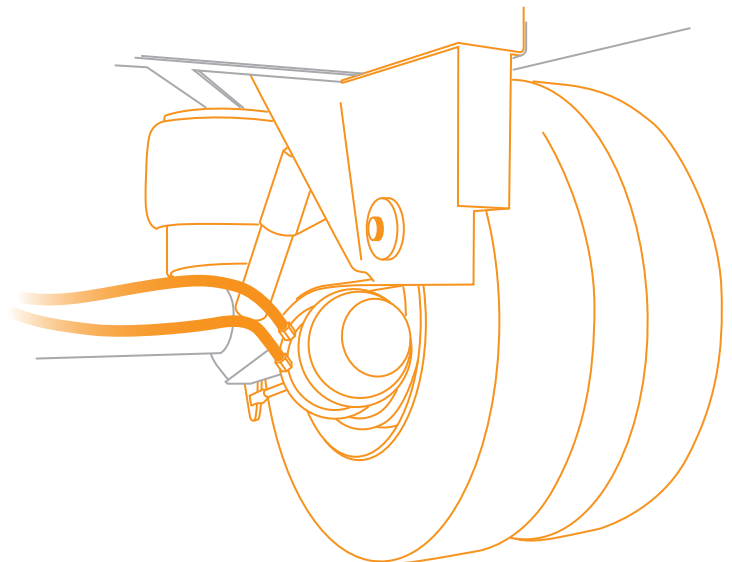
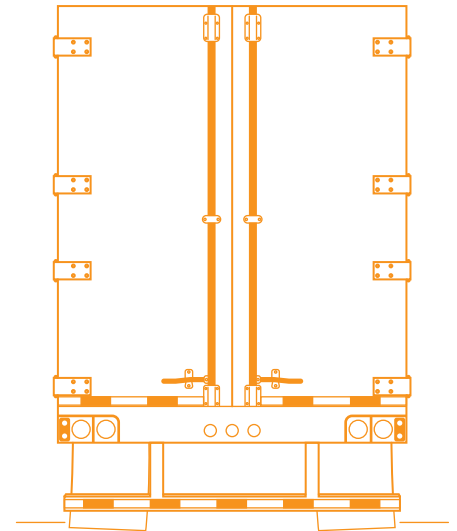



# External Light Check

**ABC**–Abrasions, Bruises, Cuts    **BBC**–Bent, Broken, Cracked    **Not Leaking**–air and liquid-holding parts  
**Wear Gloves**–touch every part you inspect    **Order**–inspect from the top down and from the center out

Make It Easy: **Truck first, then trailer**

**Front of truck:**

clearance lights  
headlights  
high beams  
left turn  
right turn  
4-way flashers

**Left side of truck:**

clearance light  
left turn  
4-way flashers

**Rear of Truck:**

brake lights  
tail lights  
left turn  
right turn  
4-way flashers

**Right side of truck:**

clearance light  
right turn  
4-way flashers

**Front of trailer:**

clearance lights

**Left side of trailer:**

clearance light  
left turn  
4-way flashers

**Rear of trailer:**

clearance lights  
tail lights  
brake lights  
left turn signal  
right turn signal  
4-way flashers

**Right side of trailer:**

clearance light  
right turn  
4-way flashers

There are 26 lights to check.  
Follow the logical flow and you shouldn't miss any. 4 sides for the truck, 4 sides for the trailer.

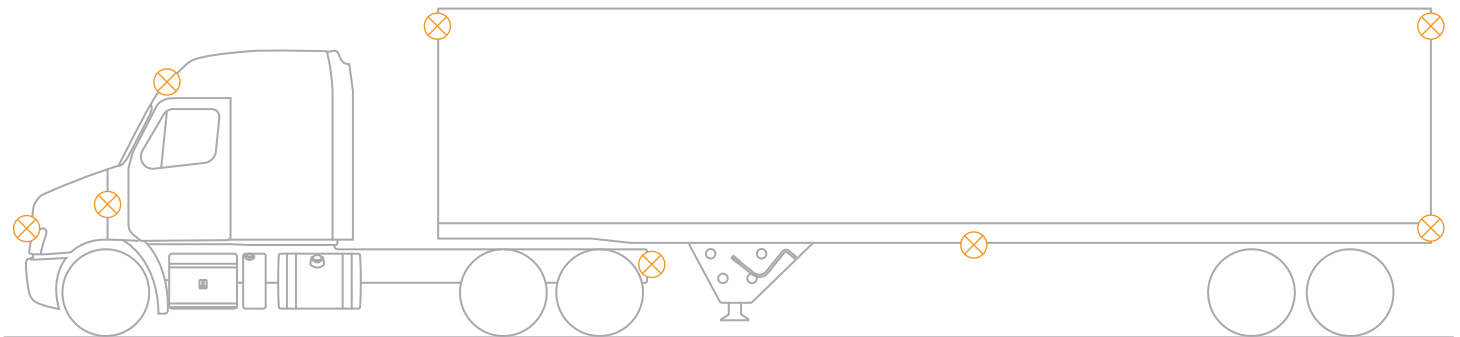



# In-Cab/Brake Check

**ABC**–Abrasions, Bruises, Cuts    **BBC**–Bent, Broken, Cracked    **Not Leaking**–air and liquid-holding parts  
**Wear Gloves**–touch every part you inspect    **Order**–inspect from the top down and from the center out

Make It Easy: **All 5's**

**Seat belt:** securely mounted, belt has no cuts or frays, adjusts properly, and latches and unlatches.  
**Horns:** ensure that both horns are operational.  
5 **Fire extinguisher:** properly charged and rated, securely mounted, pin in place.  
**3 Triangles:** securely mounted, not BBC, none missing.  
**Fuses:** must have spare fuses or circuit breakers; if vehicle does not use fuses, mention to tester.



After inspecting your safety items, **turn the key on** and continue your inspection.

**Mirrors & windshield:** glass not dirty or BBC, no illegal stickers, mirrors properly adjusted.  
5 **Windshield wipers:** arms securely mounted, not BBC, blades have no splits or cuts, w/w fluid is operational.  
**Heater/defroster:** demonstrate both are operational.  
**Dashboard light indicators:** (turn exterior lights on) high beams, right and left turn signals, 4-way flashers.

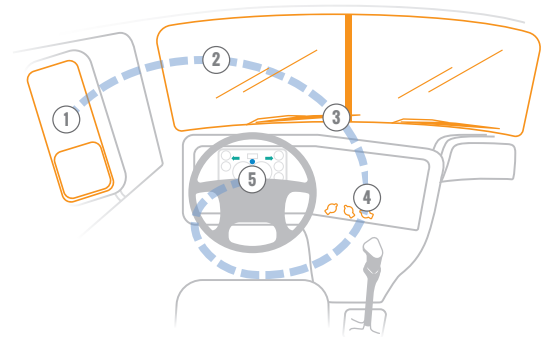

**Safe Start.** Tell the examiner these 3 steps before you perform them: parking brake is set, transmission in neutral, and the clutch is depressed. Start the engine and look for the **ABS light** on the dash to come on and then go off. With the vehicle started, check the gauges.

**Oil gauge:** operational, rising to proper operating range, no warning light.  
5 **Temperature gauge:** operational, rising to proper operating range, no warning light.  
**Voltmeter:** operational, rising to proper operating range, no warning light.  
**Air gauges (2):** building air to proper operating range.

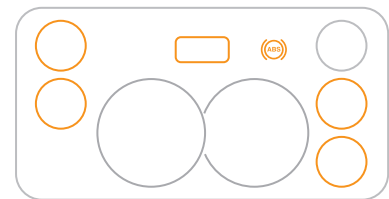

**Brake Check.** Start by checking the parking brake. To do so, the engine must be running. (Explain each step before performing them.)

**Parking Brake:** release trailer brake (**push RED valve IN**), tug lightly against it.  
**Service Brake:** (brake pedal) release parking brake (**BOTH valves should be IN**), pull forward to 5 mph, depress clutch and brake while lightly gripping the steering wheel; check if vehicle pulls to the left or right.

**Leave truck in gear and valves pushed in. Turn engine off, but key ON (gauges) for next 3 steps. (THE NEXT 3 STEPS MUST BE PERFORMED to avoid an automatic fail on the Pre-Trip).**

5 **Applied Test:** depress and hold brake pedal, air gauges cannot lose more than 4psi in 1 minute (3psi for Class B).  
**Fanning Test (Low Air Warning):** fan brake pedal until the air gauge reads **~60psi at which point a low-air emergency light and/or buzzer** should come on.  
**Emergency Spring Brakes (Pop-Out):** continue fanning the brakes down to **40-20psi, at which point the brake valves should pop out**. Look at the valves, not the air gauge. Do not pull the valves out!

**Note:** if you forgot to turn the key on for the last 3 steps, tell the tester. Then begin again with the Applied Test.