



# **BRP-ROTAX**

## **FR125 Max**

### **TECHNICAL SPECIFICATIONS**



UPDATED JANUARY 2011



## BRP-ROTAX FR125 Max ENGINE TECHNICAL SPECIFICATIONS

### Preamble:

The following are the Technical Specifications for the BRP-ROTAX FR125 Max engine, as approved by the Australian Karting Association.

This engine is approved for use in the following classes.

- Formula Rotax 125 Light
- Formula Rotax 125 Heavy
- TAG 125
- Restricted 125
- Open Performance

Unless otherwise specified, the engines must be original in all their components according to the Rotax FR125 Max drawings.

Any removal, addition or polishing of material is strictly forbidden.

Sandblasting, glass bead blasting, peening, acid etching, spark eroding and/or any other method of metal removal or displacement is not allowed.

**ANY ALTERATIONS / MODIFICATIONS ARE STRICTLY PROHIBITED EXCEPT AS SPECIFICALLY AUTHORISED WITHIN THESE SPECIFICATIONS.**

**IF THESE SPECIFICATIONS DO NOT SAY YOU CAN MAKE A MODIFICATION, THEN YOU CANNOT.**

### RMAX 1.01 Internal and External Additions

No additional material may be added except in the case of engine repairs and shall only restore the engine or components to original specifications.

- The use of thermal barrier coatings / ceramic coatings on or in the engine and on or in the exhaust system is prohibited.
- The use of anti-friction coatings in or on the engine / engine components is prohibited.
- The only exceptions to this are the gilynasil coating of the cylinder bore and the coating to the piston skirt.

### RMAX 1.02 Legal Additions

Chainguard, motor mount, radiator mount, temperature gauge and tachometer / hour meter. Modifications to fit an exhaust probe are permissible. Refer Rule 25.09.

### RMAX 1.03 Non Tech items

- 1 Battery, Fuel filter, Radiator Hoses, Clamps, Pulse line, Switches, Ancillary Mounts, Fasteners, circlips, washers, bearings, spark plugs, gaskets, o-rings, piston pin, springs, seals, clutch drum, engine sprocket, rings, starter motor, clutch flywheel, thermostats and housings, unless otherwise specified. Clutch Drum Evolution (AKA #48 approved Part ID #659154)
- 2 No alteration from the original manufacturers specification is permitted to fit a non-tech item.
- 3 Additional fasteners or securing devices are non tech items and may be fitted/added.

### RMAX 1.04 Cylinder Head Volume

Minimum of 11.0cc using AKA method 22.03.

### RMAX 1.05 Displacement

125.0cm<sup>3</sup> (maximum)

### RMAX 1.06 Combustion Chamber Insert

1. Identification code has to be 223 389 or 223 389 1 or 223 389 2 (illustration 1, (4)).
2. No material may be added except to repair the spark plug thread and or spark plug sealing surface. Machined surfaces may be re-machined only if using cylinder 223997. Cylinder head insert must retain both the squish band and a visually spherical combustion chamber. O ring must be fitted.
3. The combustion chamber/squish area shall not protrude beyond the sealing face of the cylinder head insert.
4. "Rotax" and/or "Made in Austria" must be cast in the combustion chamber insert.
5. If using Cylinder 223996 or any future cylinder evolution, the combustion chamber insert must remain as supplied by the manufacturer. The profile of the combustion chamber insert has to be checked with the combustion chamber insert template (Rotax part no. 277390). The crack of light between the template and the profile of the combustion chamber insert has to be the same over the entire profile.

### RMAX 1.07 Spark plug thread length

Maximum spark plug thread length shall be 20mm.



## BRP-ROTAX FR125 Max ENGINE TECHNICAL SPECIFICATIONS

### RMAX 1.08 Piston

1. OEM only, uncoated or coated, aluminium, cast piston with one 1.0mm rectangular piston ring the piston has to show on the inside the words "ELKO" and "Made in Austria" in the casting.
2. Machined areas are: top end of piston, outside diameter, one groove for the piston ring, bore for the piston pin, inside diameter at bottom end of piston. All other surfaces are not machined and have cast surface

### RMAX 1.09 Gudgeon Pin

1. Gudgeon pin to be made of magnetic steel
2. Must be as per illustration 8.

### RMAX 1.10 Cylinder

1. Light alloy cylinder with GILNISIL plating, configuration with one main exhaust port and pneumatic adjusted valve. Any replating is not allowed.
2. Maximum bore: 54.035mm (measured 10 mm above the exhaust port).
3. Cylinder has to be marked with ROTAX logo, (illustration 2, (1)).
4. Cylinder has to be marked with identification code: 223997 or 223996 or 223993 (illustration 2, (2)).
- 4a. Cylinder 223997 is eligible for use in AKA competition until 31/12/2011. **After this date, it will only be eligible for use in TAG Restricted class until 31/12/2013. (Add # 7, 2011)**
5. All ports and passages are cast finish except some pre-existing factory removal of flashing. All ports have chamfered edges to prevent ring snagging. Any additional machining is not permitted.
6. Cylinder must have the official Formula Rotax Australia stamp on the inlet face.
8. Refer to Rule 26.04, Steps 1,2,3 and 5 for compliance checking procedure.
9. If you are using cylinder 223997, the cylinder base surface may be re-machined but must remain perpendicular to the cylinder bore.
- 9a. If you are using cylinder 223996 or any future cylinder evolution, the cylinder must remain as supplied by the manufacturer and cannot be re-machined. Height of cylinder must be 87mm with tolerance of  $-.05/+0.1$  mm.
10. Due to manufacturing procedures some cylinders may have been machined on the exhaust flange.
11. If the engine fails the field test, it is to be sealed and sent to the State Technical Officer for second and final verification of compliance using an analogue or digital indicator **checked against the measurements in the summary table of piston travel measurements in millimetres – Rule 26.04. Refer to addendum 1, 2011. (Add #7, 2011)**

### RMAX 1.11 Cylinder Base Gaskets

1. Must be dimensionally the same size and shape as original and cannot be designed to decrease the size of the transfer ports.

### RMAX 1.12 Inlet System

1. Intake manifold is marked with the name ROTAX and the identification code 267 915. No grinding or machining is permitted. However some factory flash removal may be present at the junction of the inside contour and the carburettor stop mounting face. This is a manual trimming operation consisting of a small corner break of less than 1mm in width.
2. Reed valve assembly is marked with the name ROTAX and the identification code 224387. No grinding or machining is permitted – Reed block Evolution (AKA #49) approved - Part ID 224389
3. The reed valve assembly is equipped with 2 petal stops and 2 reeds, each having 3 petals.
4. The thickness of the reeds is 0.6mm +/- 0.08mm
5. Maximum reed block gasket/spacer thickness is 4.0mm
6. The addition of one Rotax reed block gasket, maximum of 1.0mm between the carburettor manifold and the reed block is permitted.



## BRP-ROTAX FR125 Max ENGINE TECHNICAL SPECIFICATIONS

### RMAX 1.13 Exhaust Power valve

1. As supplied by the manufacturer with no modifications allowed
2. Compression spring must be fitted
3. Any adjustment or blocking to this once the engine is running is illegal.
4. Maximum thickness of power valve gasket/s is 2.0 mm
5. Additional fasteners or securing devices may be fitted/added.
6. Length of exhaust valve is 36.5mm +0.2mm/-0.3mm
7. Width of collar is 4.8mm +/-0.3mm

Exhaust Valve Evolution (AKA #50) approved Part ID 230260

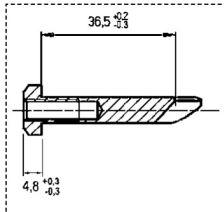

### RMAX 1.14 Crankshaft

1. As supplied by the manufacturer with no modifications permissible.
2. Stroke 54.5mm +/-0.02mm

### RMAX 1.15 Balance Shaft

1. Balance shaft and balance gears must be installed and operational.
2. Part numbers 237 945 and 237 949 (equal to 237 948) are legal.
3. Surface (1) is not machined and must be cast finish.
4. Measurement from center of balance shaft to outer diameter of flyweight of balance shaft at defined length must not be lower than specified (see illustration 4.1)
5. The minimum weight of the dry balance shaft must not be lower than 355 grams for balance shaft 237 945 and 255 grams for balance shaft part number 237 949 (equal with 237 948)
6. Balance gears must be installed and must be correctly aligned according to the instruction in the repair manual.
7. Both the plastic balance gears (Rotax part #234431) or the steel balance gears (Rotax part #234436 and 234435) are permitted.

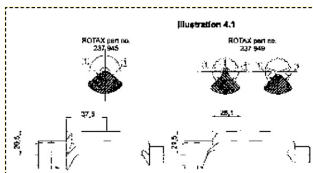

### RMAX 1.16 Conrod

1. As supplied by the manufacturer. Any grinding / polishing or modifications is not permitted
2. Conrod has to be marked with "213" or "365" or "367" on shaft, (see illustration 4, (7)).

### RMAX 1.17 Crankcase

1. As supplied by the manufacturer. No grinding / polishing in the two main transfer passages.
2. Must have the official Formula Rotax Australia stamp on crankcase deck.
3. Either sandcast gearbox cover (part no.211870) or pressure die cast gearbox cover (part no.211871) is permitted.

### RMAX 1.18 Ignition

1. DENSO digital ignition only, no adjustment permitted or possible.
2. Ignition coil has the following marks close to the outlet of the high-tension cable, cast in the case: Denso and 129000.
3. The only allowable Spark Plug Cap is NGK type TBO5EMA.
4. Any modification to any part of the ignition system and/or crankshaft to alter the ignition timing or rev limiter is illegal.
5. The ignition coil must have 3 pins at the terminal.
6. The ignition pickup must be marked with the numbers 029600-0710, followed by a variable production code in the second line.



## BRP-ROTAX FR125 Max ENGINE TECHNICAL SPECIFICATIONS

### **RMAX 1.19 Carburettor: DELL'ORTO carburettor**

1. The carburettor body, slide, needle, atomiser tube and atomiser (either spec 1 or spec 2 is permissible) to remain as originally supplied and cannot be subject to any modification. No additions or additional machining filing, drilling, or polishing etc is permitted to these items, this includes the bore /throat
2. "VHSB 34" cast in the housing of the carburettor
3. "QD" or "QS" stamped in the housing of the carburettor.
4. Atomiser tube stamped with "266 FN"
5. Needle stamped with "K54" or "K27" and "K98" or others as nominated in the future.
6. Slide marked #40 only.
7. The size of any hole in any of the following is unregulated: main jet, needle and seat, pilot jet, pilot jet emulsion insert, choke jet. The position of the float/float arms and the weight of the floats are unregulated. All items (jets, needles etc) referred to in Rule 28.27 must be present and operational.
8. With the exception of the choke, no changes or adjustments can be made to the carburettor once the engine is running.

### **RMAX 1.20 Fuel Pump**

MIKUNI diaphragm pump only. Place of fixing is free.

### **RMAX 1.21 Radiator**

1. Genuine single aluminium radiator as shown in [illustrations 5, 5.1 and 5.2](#).
2. Cooling area: Height = 290mm, width = 133mm
3. Thickness of radiator = 32mm
4. 12 only water cores are permissible.
5. Placement of the radiator is free, however for the warranty to exist, the radiator must be mounted in its original position, on the right side of the engine.
6. Additional cooling devices are not permitted, [except for the lexan plastic shield as shown in illustration 5.2](#).
7. The removal of the thermostat from the cylinder head cover is acceptable

### **RMAX 1.22 Radiator Coolant**

As glycol coolants are not permitted, a mixture of distilled water and aluminium compatible anti-freeze has to be used. An example of a product that does not contain glycol is Valvoline Pyroil Radiator Corrosion inhibitor.

### **RMAX 1.23 Clutch**

Dry centrifugal clutch – using genuine components only. Whilst on level ground the kart (with driver in kart) must start to move under its own power, when the engine speed reaches 3000 R.P.M. or less. The use of the Clutch Pin support plate is permitted.

[Only genuine Rotax clutches are permitted \(Rotax Part #659902 and #65907](#)

### **RMAX 1.24 Intake Silencer**

1. Intake silencer with integrated, washable air cleaner as shown in illustration 6, must be fitted.
2. No modifications allowed. Air filter must be in place as per illustration 6. Either fine type or coarse 030 filter is permitted.
3. It is permissible to drill a single 5 mm hole in the lower part of the intake silencer (in the centre of the plastic injection mark)
4. Either type airbox as shown in Illustration 6 or Evolution type (part numbers 225025 and 225 015, which incorporates a 8mm drain hole) is permitted.



## BRP-ROTAX FR125 Max ENGINE TECHNICAL SPECIFICATIONS

### RMAX 1.25 Exhaust System

1. Must be as supplied by Rotax and cannot be modified except for, a) the replacement of the silencer absorption material and /or b) Modifications to fit an exhaust probe are permissible. Refer Rule 25.09
2. Standard engine / pipe coupling must be used.
3. Exhaust pipe with after muffler as shown in illustration 7.
4. Length of inlet cone: Type A and B: 592mm +/- 5mm (measured along the body of the exhaust pipe, not the seam, from the beginning of the exhaust to the start of the cylindrical part).
5. Length of cylindrical part of exhaust pipe: Type A and B: 125mm +/- 5mm.
6. Length of end cone: Type A: 250mm +/- 5mm, Type B: 225mm +/- 5mm (measurement see illustration 7).
7. Outside diameter of 180° bent tube: Type A: 30mm, +/- 3mm, Type B: 41mm + 1.5mm / - 1,0mm (measured at beginning and end of bend).
8. Hole diameter of end cap of silencer (illustration 7,) 21mm + 0.2mm – 0.5mm.
9. Painting / plating of the exhaust muffler is permitted with the exception of thermal barriers / coatings / paint. (See internal and external additions)
10. Note : Any accidental damage to the unit will not incur a technical breach of these rules, however any attempt to modify/alter the exhaust system by cutting, or fabrication will automatically remove eligibility of the exhaust system. Welding of the exhaust system to repair a crack, hole or to fit a patch etc. is permitted.
11. Only one exhaust gasket is permitted, maximum thickness of 2mm.

### RMAX 1.26 Exhaust Muffler

1. Noise isolating mat (illustration 7, pos. 2 & 5) can only be replaced by an original ROTAX spare part.
2. End cap rivets may be replaced with bolts / capscrews etc.

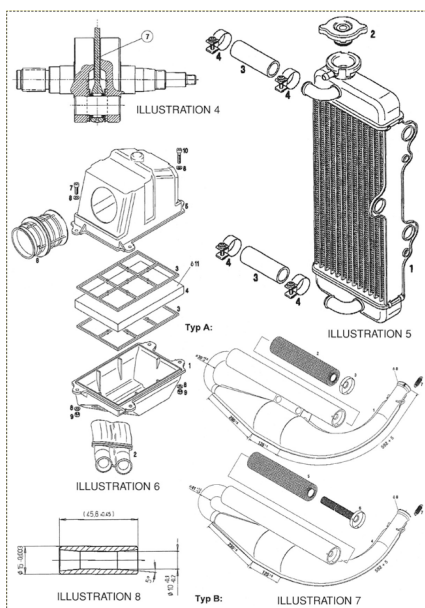
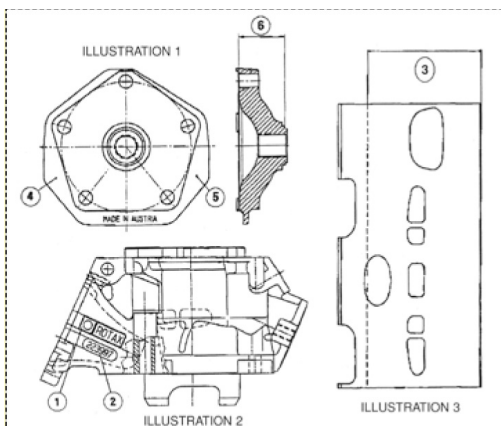



# BRP-ROTAX FR125 Max ENGINE TECHNICAL SPECIFICATIONS

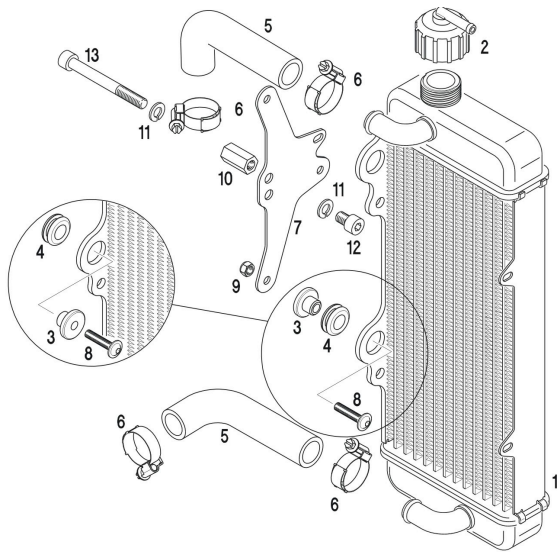

ILLUSTRATION 5.1 ROTAX RADIATOR

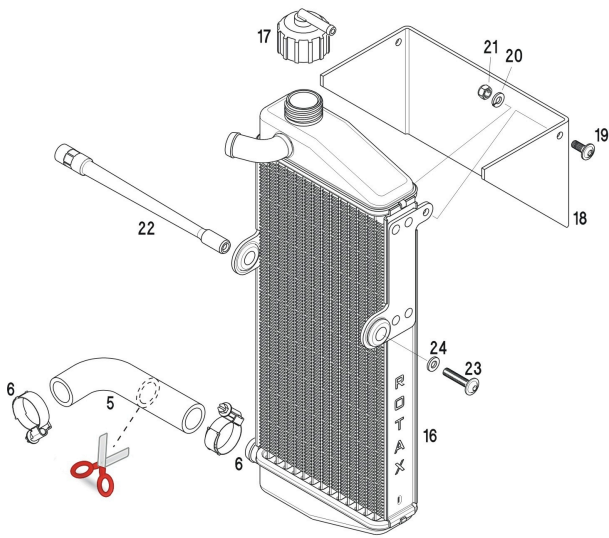

ILLUSTRATION 5.2 NEW ROTAX RADIATOR WITH LEXAN PLASTIC SHIELD.