

INSTRUCTION MANUAL

FOR

VOLTAGE REGULATOR

APR 125-5

P/N 9168800100

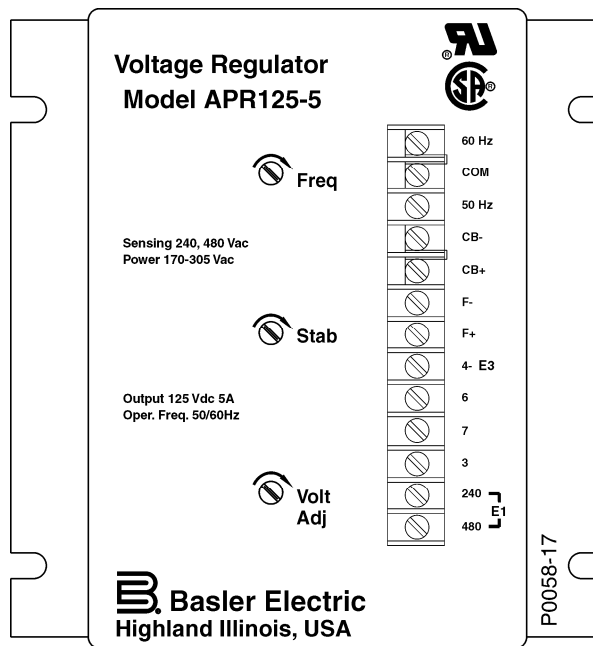

B Basler Electric

Publication: 9168800990
Revision: J 03/09

INTRODUCTION

This instruction manual provides information about the operation and installation of the APR 125-5 voltage regulator. To accomplish this, the following information is provided:

- General Information and Specifications
- Functional Description
- Installation
- Maintenance and Troubleshooting

WARNING!

To avoid personal injury or equipment damage, only qualified personnel should perform the procedures in this manual.

First Printing: May 1985

Printed in USA

© 2009 Basler Electric, Highland Illinois 62249 USA

All Rights Reserved

March 2009

CONFIDENTIAL INFORMATION

of Basler Electric, Highland Illinois, USA. It is loaned for confidential use, subject to return on request, and with the mutual understanding that it will not be used in any manner detrimental to the interest of Basler Electric.

It is not the intention of this manual to cover all details and variations in equipment, nor does this manual provide data for every possible contingency regarding installation or operation. The availability and design of all features and options are subject to modification without notice. Should further information be required, contact Basler Electric.

**BASLER ELECTRIC
ROUTE 143, BOX 269
HIGHLAND IL 62249 USA**

<http://www.basler.com>, info@basler.com

PHONE +1 618.654.2341

FAX +1 618.654.2351

REVISION HISTORY

Substantive changes made to this manual (9168800990) are listed below.

Manual Revision and Date	Change
H, 07/01	<ul style="list-style-type: none">• Corrected Figure 3-5 to show 240 Vac connection from transformer• Added UL recognition and CSA certification• Updated style of manual
I	<ul style="list-style-type: none">• This revision level not used
J, 03/09	<ul style="list-style-type: none">• Revised caption of Figure 3-2 to show external voltage adjustment potentiometer value instead of part number• Updated illustrations of front panel to reflect use of new overlay• Made minor text and illustration changes throughout manual

This page intentionally left blank.

CONTENTS

SECTION 1 • GENERAL INFORMATION	1-1
DESCRIPTION.....	1-1
SPECIFICATIONS	1-1
Output Power (With 240 Vac Input).....	1-1
Exciter Field DC Resistance.....	1-1
Power Input.....	1-1
Sensing Input.....	1-1
Voltage Adjustment	1-1
Regulation.....	1-1
Voltage Buildup	1-1
Frequency Compensation	1-2
Overexcitation Shutdown.....	1-2
Power Dissipation.....	1-2
EMI Suppression	1-2
Vibration.....	1-2
Shock.....	1-2
Temperature	1-2
Agency Recognition.....	1-2
Weight.....	1-2
SECTION 2 • FUNCTIONAL DESCRIPTION	2-1
OVEREXCITATION SHUTDOWN	2-1
ACCESSORY ITEMS.....	2-1
Power Isolation Transformer	2-1
Paralleling Module	2-1
Manual Voltage Control.....	2-1
Current Boost System	2-1
SECTION 3 • INSTALLATION	3-1
MOUNTING.....	3-1
CONNECTIONS.....	3-1
Connection Procedure.....	3-4
SECTION 4 • OPERATION.....	4-1
INTRODUCTION.....	4-1
PRELIMINARY SETUP	4-1
SYSTEM STARTUP.....	4-1
OVEREXCITATION SHUTDOWN	4-2
ADJUSTMENTS.....	4-2
Field Flashing	4-2
Frequency Roll-Off Adjustment	4-2
Stability Adjustment.....	4-2
Voltage Adjustment	4-3
OPERATIONAL TEST	4-3
SECTION 5 • MAINTENANCE.....	5-1
PREVENTIVE MAINTENANCE	5-1
TROUBLESHOOTING	5-1

This page intentionally left blank.

SECTION 1 • GENERAL INFORMATION

DESCRIPTION

The Basler Electric APR 125-5 voltage regulator is an epoxy-potted unit housed in a metal case. The voltage regulator controls the dc exciter field power to regulate the output voltage of medium-size, 50 or 60 hertz brushless generators that have a 125 Vdc field. Regulation is provided by sensing the generator output voltage, converting it to a dc signal and comparing the signal to a reference voltage. An error signal is developed and used to control the dc field power in order to maintain a constant generator output.

SPECIFICATIONS

APR 125-5 electrical and physical specifications are listed in the following paragraphs.

Output Power (With 240 Vac Input)

Maximum Continuous:	5 Adc at 125 Vdc (625 W)
Forcing (1 Minute):	8 Adc at 200 Vdc (1,600 W)

Exciter Field DC Resistance

Minimum:	25 Ω
Maximum:	100 Ω

Power Input

Range:	190 to 277 Vac, $\pm 10\%$, single-phase, 50/60 Hz
Burden:	1,000 VA, maximum

Sensing Input

Voltage

240 Vac Input:	190/220 Vac at 50 Hz, nominal 208/240 Vac at 60 Hz, nominal
480 Vac Input:	380/400/415 Vac at 50 Hz, nominal 416/450/480 Vac at 60 Hz, nominal

Burden:	1 VA
---------	------

Voltage Adjustment

Range: 170 to 264 Vac or 340 to 528 Vac using the front-panel voltage adjustment control.

External Rheostat: A 5 k Ω , 2 W, locking-shaft potentiometer with a slotted shaft is supplied with the APR125-5 for remote mounting. The external rheostat provides a $\pm 10\%$ adjustment of the nominal value determined by the front-panel voltage adjustment control.

Regulation

Accuracy:	$\pm 0.25\%$
Voltage Drift:	$< \pm 1\%$ voltage variation for a 50°C (90°F) change
Response Time:	< 1.0 cycle

Voltage Buildup

The APR 125-5 has internal provisions for automatic voltage buildup from generator residual voltages as low as 6 Vac.

Frequency Compensation

See Figure 1-1 for the APR 125-5 frequency compensation curves.

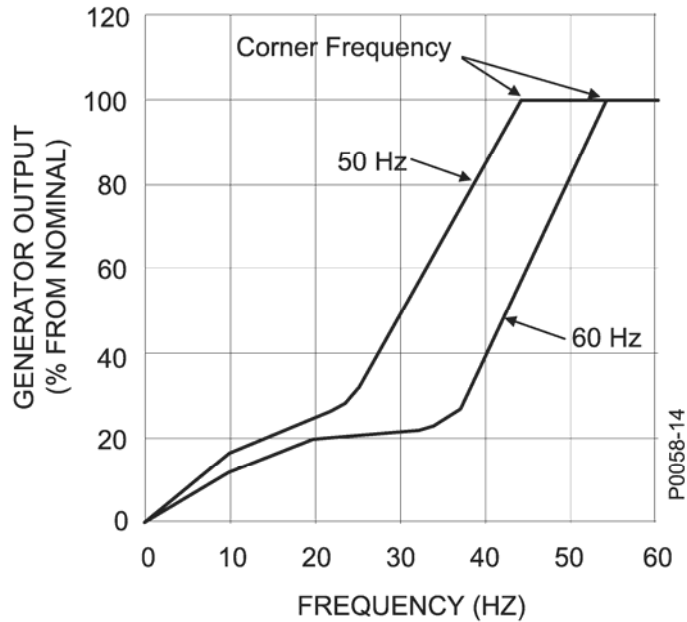

Figure 1-1. APR 125-5 Frequency Compensation Curves

Overexcitation Shutdown

See Section 2 for details of overexcitation shutdown operation.

Power Dissipation

25 W, maximum

EMI Suppression

Internal filter provides electromagnetic suppression.

Vibration

Withstands:

- 1.2 G at 5 to 26 Hz
- 0.036" (0.914 mm) double amplitude at 27 to 53 Hz
- 5.0 G at 54 to 1,000 Hz

Shock

Withstands up to 15 G in each of three mutually perpendicular axes.

Temperature

Operating: -40 to 70°C (-40 to 158°F)
Storage: -65 to 85°C (-85 to 185°F)

Agency Recognition

UL Recognition: Per Standard 508, UL file No. E97035
CSA Certification: Per Standard CAN/CSA-C22.2, No. 14-M91, CSA file No. LR23131

Weight

Net: 5.1 lb (2.3 kg)
Shipping: 6.1 lb (2.77 kg)

SECTION 2 • FUNCTIONAL DESCRIPTION

OVEREXCITATION SHUTDOWN

If the exciter field voltage exceeds 190 Vdc, the voltage regulator automatically removes the field current after a time delay. This time delay is inversely proportional to the magnitude of the detected overvoltage condition (see Figure 2-1). At approximately 280 Vdc, the field voltage is removed instantaneously. Overexcitation shutdown will not occur below 160 Vdc.

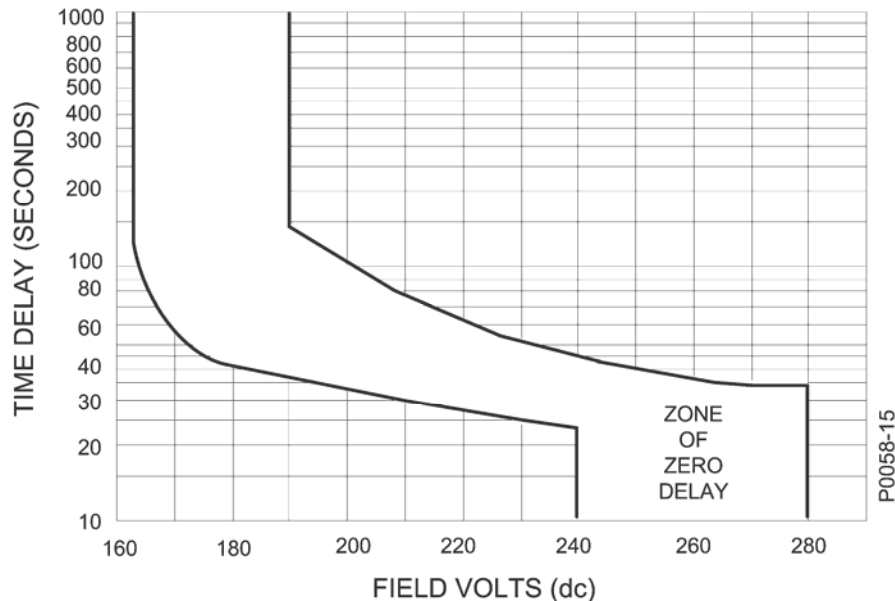

Figure 2-1. Typical Inverse Time Delay Characteristic Curves

Upon detection of overexcitation and the resulting field voltage shutdown, the voltage regulator will not reset or return to an operational condition until the generator output decreases to less than 6 Vac for a minimum of 10 seconds.

ACCESSORY ITEMS

Power Isolation Transformer

A low-voltage, power isolation transformer can be used to provide electrical isolation and match voltages from the generator to the voltage regulator. To obtain maximum voltage regulator output power (exciter field resistance of 25 to 30 Ω), select a power isolation transformer of 1.0 kVA or greater. For field resistances of 30 Ω or higher, the transformer may be derated (500 VA at 50 Ω , 250 VA at 100 Ω).

Paralleling Module

To parallel two or more generators using droop or cross-current compensation, use an APM 2000 paralleling module and a current transformer with a 5 Aac nominal secondary.

Manual Voltage Control

The MVC 300 manual voltage control offers backup excitation for the regulator in critical applications. The regulated output of this electronic device improves the performance of a generator using traditional types of manual control.

Current Boost System

The CBS 320 uses the APR 125-5 and a current transformer (to tap the generator's line current) to boost the field current during short-circuit conditions or large motor starting.

This page intentionally left blank.

SECTION 3 • INSTALLATION

MOUNTING

The APR 125-5 may be mounted in any position using quarter-inch hardware and may be mounted directly on the generator. Select the proper mounting hardware to withstand any expected operating and shipping/transportation conditions. Outline dimensions for the APR 125-5 and external voltage adjust control are shown in Figures 3-1 and 3-2. Dimensions are listed in inches with millimeters in parenthesis.

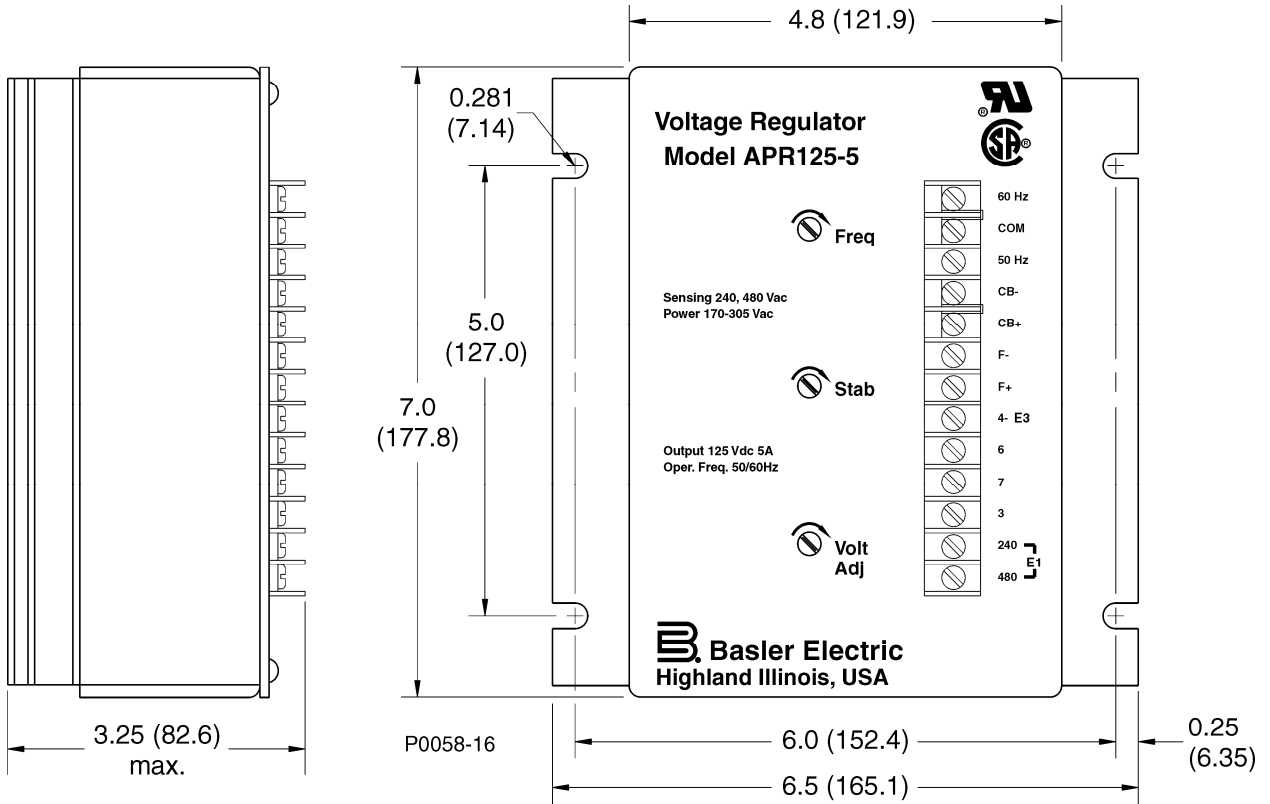

Figure 3-1. APR 125-5 Outline Dimensions

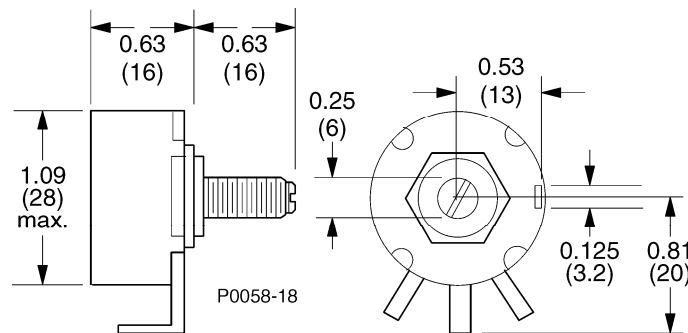

Figure 3-2. External Voltage Adjust Potentiometer, 5 kΩ, 2 W

CONNECTIONS

APR 125-5 interconnection diagrams are provided in Figures 3-3, 3-4, and 3-5. Figure 3-3 illustrates 208/240 Vac connections, Figure 3-4 illustrates 410/450/480 Vac connections, and Figure 3-5 illustrates APR 125-5 interconnection with an isolation transformer.

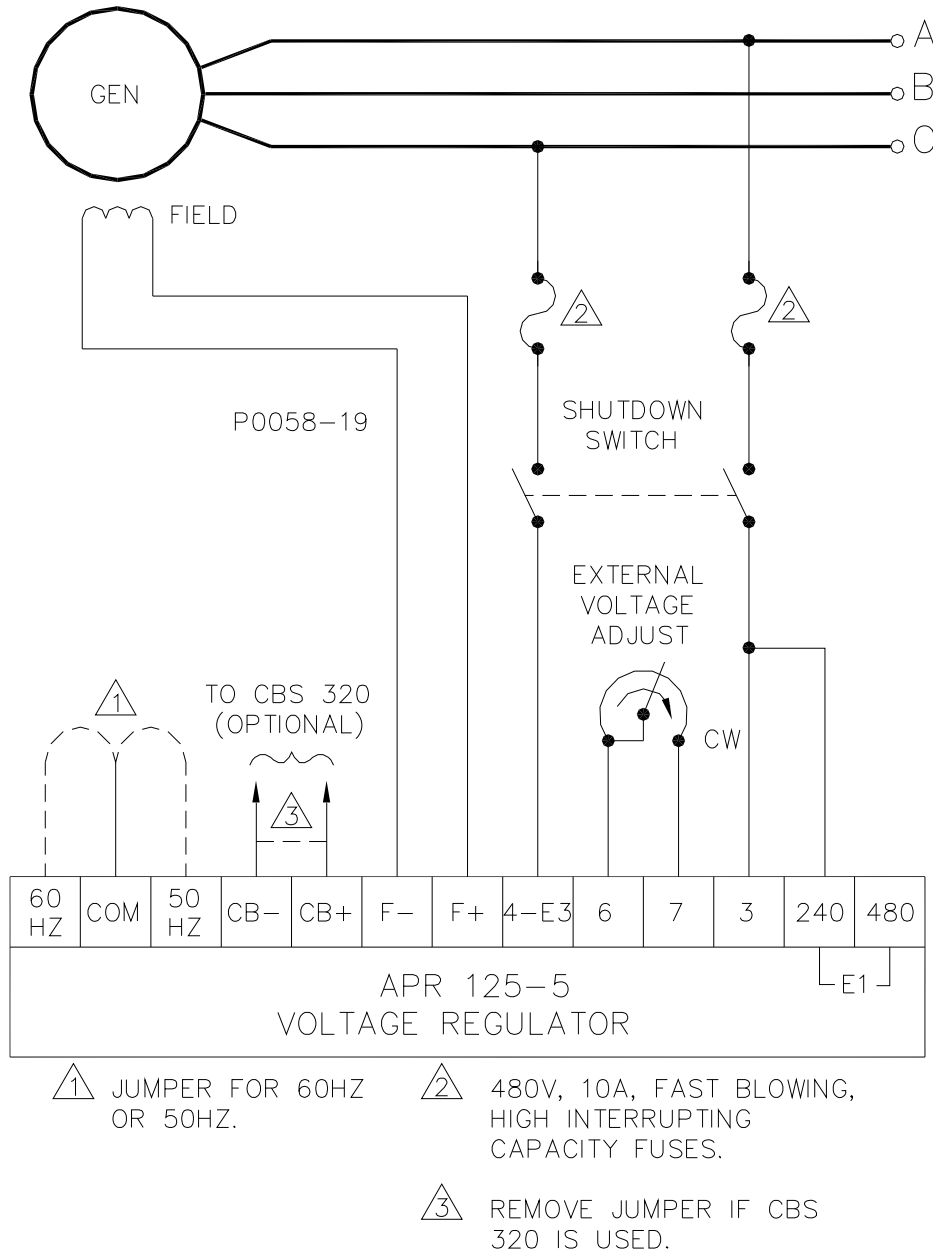

Figure 3-3. 208/240 Vac Interconnection Diagram

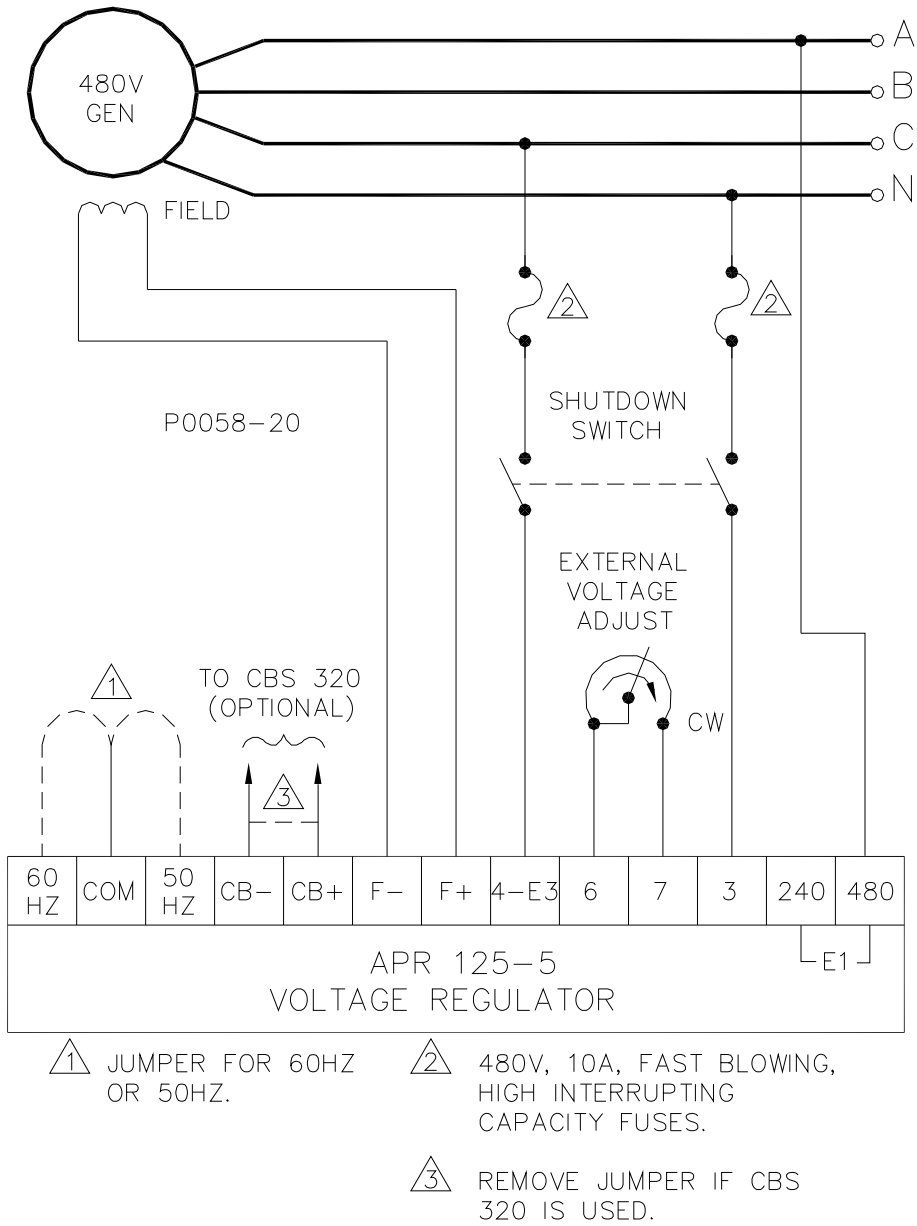

Figure 3-4. 410/450/480 Vac Interconnection

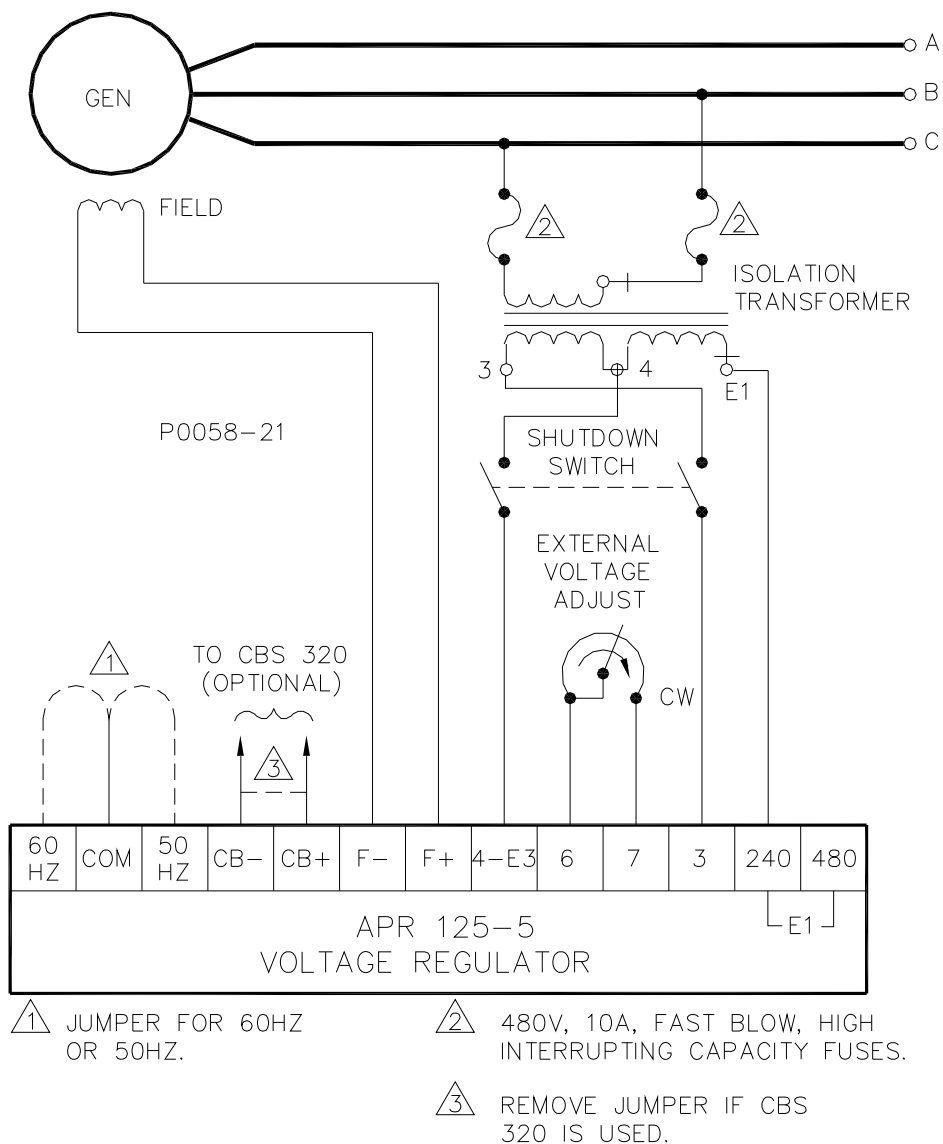

Figure 3-5. Isolation Transformer Interconnection

Connection Procedure

1. Configure the APR 125-5 for 50 or 60 Hz operation by connecting the terminal block jumper across the COM and 50 Hz or COM and 60 Hz terminals.
2. If a CBS 320 Current Boost System will be used with the APR 125-5, remove the jumper connected across terminals CB- and CB+ and connect the CBS 320 to these terminals. If a CBS 320 is not used, leave the jumper across terminals CB- and CB+ in place.
3. If the external voltage adjust potentiometer (supplied with the APR 125-5) will be used, connect it across terminals 6 and 7 as shown in Figures 3-3 through 3-5. If the potentiometer won't be used, connect a jumper across terminals 6 and 7.
4. Observing the proper polarity, connect terminals F+ and F- to the exciter field.
5. Connect APR 125-5 operating power from the generator stator to terminals 3 and 4-E3. The applied voltage must be within the range of 190 to 277 Vac. Both operating power inputs should be protected with fuses. If desired, install an optional shutdown switch.
6. Connect the sensing voltage source to terminals 240 (E1) and 4-E3 or 480 (E1) and 4-E3. These connections should be connected line-to-line and depend upon the voltage level of the sensing source.

SECTION 4 • OPERATION

INTRODUCTION

The following procedures provide instructions for starting, operating, and adjusting the APR 125-5 voltage regulator. A troubleshooting guide lists symptoms of startup problems that may result from incorrect regulator adjustment and certain generator system problems that resemble faulty regulation with possible solutions.

NOTE

During periods of prime mover idling (operation at reduced speeds), use the shutdown switch to remove voltage regulator operating power.

PRELIMINARY SETUP

To prevent damage to the voltage regulator, the following precautions should be taken before proceeding with system startup.

- Verify that the voltage regulator specifications conform with the generator system requirements.
- Ensure that the voltage regulator has been installed and connected in accordance with Section 3.

SYSTEM STARTUP

Table 4-1 lists the steps associated with system startup, the problems that may be encountered, and the possible solutions to these problems.

Table 4-1. System Startup Procedure/Troubleshooting Guide

Procedure	Symptom	Remedy
1. Perform the precautions listed under <i>Preliminary Setup</i> .	N/A	N/A
2. Start the prime mover and bring it up to rated speed.	Voltage does not build up.	a. Flash the field. b. Troubleshoot
	Voltage builds and then decays.	Troubleshoot
3. Slowly adjust the VOLT adjustment or external voltage adjust potentiometer until the voltage reaches nominal.	Voltage does not build up to rated value.	a. Check the generator output for a shorted or excessive load. b. Troubleshoot
	Voltage is high and uncontrollable.	Troubleshoot
4. Apply and remove load to check stability.	Generator response is too slow or is hunting (oscillating).	a. Check the generator output for shorted or excessive load. b. Troubleshoot
5. Check regulation under normal operating conditions.	Poor regulation.	a. Check that the prime mover is up to speed. b. Check that the voltmeter is connected at the same point as the regulator sensing. c. Use an average sensing voltmeter (not rms sensing). d. Troubleshoot

Procedure	Symptom	Remedy
6. Reduce the generator frequency to approximately 5 Hz below nominal. The generator output should decrease from this point.	Generator output voltage does not decrease at the desired frequency.	a. Check that all wiring is in accordance with Section 3. b. Adjust the regulator FREQ control.

OVEREXCITATION SHUTDOWN

The overexcitation shutdown function removes the regulator output power if the exciter field voltage exceeds 190 Vac. After regulator output power is shut down due to overexcitation, the regulator can be reset by decreasing the input voltage to less than 6 Vac for a minimum of 10 seconds. This can be accomplished by stopping the prime mover or by interrupting the regulator input with the shutdown switch.

ADJUSTMENTS

APR 125-5 adjustments include field flashing, frequency roll-off, stability, and voltage.

Field Flashing

When the voltage regulator is operated with the generator for the first time, the polarity of the generator's residual magnetism may be incorrect or insufficient magnitude. If the residual voltage present at terminals 3 and 4-E3 is greater than 6 Vac, replace the regulator. If the generator residual voltage is less than 6 Vac, stop the prime mover and proceed with the following steps.

CAUTION

Do not flash the field with the generator in motion. The voltage regulator may be damaged.
--

1. With the prime mover at rest, apply a dc source (ungrounded), of not more than 48 Vdc to terminals F+ (positive) and F- (negative) in series with a limiting resistor. Use 1 Ω of resistance for each volt from the dc power source. The resistor should have a power rating of at least 1 watt per ohm.
2. Allow the field to be flashed for approximately 10 seconds before removing the dc source.
3. If voltage buildup does not occur after performing steps 1 and 2, verify the polarity of the dc source and repeat flashing as necessary.

Frequency Roll-Off Adjustment

The APR 125-5 underfrequency adjustment is factory preset to cause an average 2 Vac drop in the generator line input voltage to the regulator when the frequency is between 55.0 and 55.6 hertz (for 60 Hz applications). For 50 hertz applications, the frequency roll-off is factory preset to between 45.75 and 47.75 hertz. To reset the frequency roll-off, proceed as follows:

1. Adjust the prime mover rpm to the desired frequency compensation (corner frequency roll-off) point.
2. Adjust the front panel FREQ control until the output voltage begins to drop off.
3. Bring the prime mover up to rated speed. The output voltage should return to normal.

Stability Adjustment

An oscilloscope or other voltage recording device should be used if a stability setting is desired that will provide the fastest possible voltage response with good generator stability. When adjusting regulator stability, note the following:

- Clockwise rotation of the front panel STAB control slows response time.
- Counterclockwise rotation of the front panel STAB control speeds response time. If rotated too far counterclockwise, the generator voltage may oscillate (hunt).

Rotate the front panel STAB control counterclockwise until the system starts oscillating and then rotate the control clockwise just past the point where oscillation occurred.

Voltage Adjustment

Installation of a jumper across terminals 6 and 7 enables the front panel VOLT control to adjust the generator nominal voltage over the range shown in Table 1-1.

The external potentiometer, supplied with the APR 125-5, may be connected in place of the jumper and will allow for a $\pm 10\%$ adjustment of the voltage range. The nominal value of this range is set by the front panel VOLT control.

If a range less-than or greater-than that provided by the supplied 5 k Ω potentiometer is desired, a 2 watt potentiometer of any value from 1,000 to 10,000 ohms may be substituted.

OPERATIONAL TEST

To perform an operational test of the APR 125-5, connect the regulator as shown in Figure 4-1 and perform the following steps.

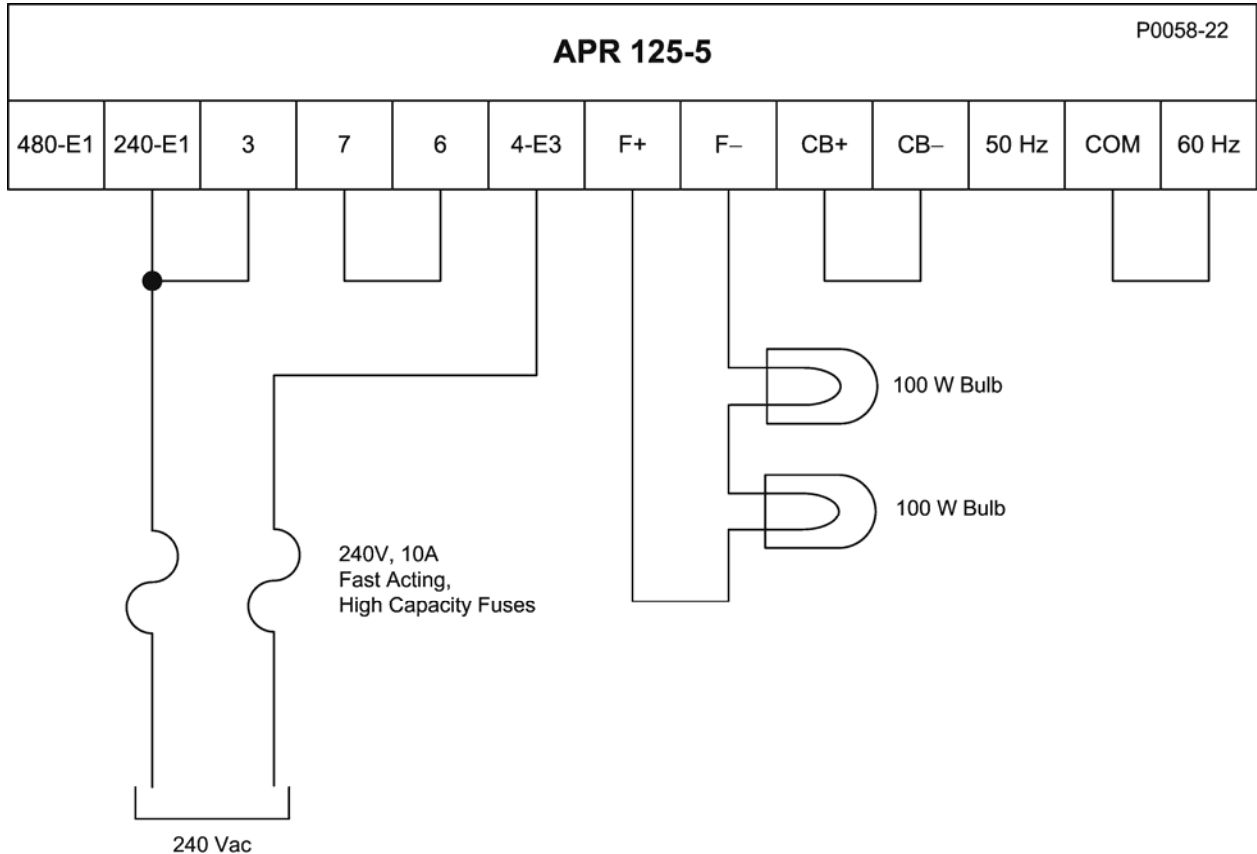

Figure 4-1. APR 125-5 Operational Test Setup

1. Apply 240 Vac to the regulator as shown in Figure 4-1.
2. Adjust the front panel VOLT control fully counterclockwise. Observe that the lamps do not light.
3. Adjust the front panel VOLT control fully clockwise. Observe that the lamps light.
4. Adjust the front panel VOLT control counterclockwise until the lamps just turn off.

Regulator operation is satisfactory if the above results are obtained. Stability, however, must be tested with the generator and regulator operating.

This page intentionally left blank.

SECTION 5 • MAINTENANCE

PREVENTIVE MAINTENANCE

The APR 125-5 voltage regulator requires no periodic maintenance other than periodic inspection to ensure that the regulator is clean and free from accumulations of dust and moisture. Be sure that all terminal connections are clean and tight.

TROUBLESHOOTING

If the regulator does not perform as expected, consult Table 5-1 for assistance with troubleshooting.

Table 5-1. Troubleshooting

Symptom	Possible Cause	Remedy
Voltage does not build up.	No voltage or incorrect voltage to power input at terminals 3 and 4-E3.	a. Flash the field. b. Verify all wiring. c. Check the fuses. d. Check the shutdown switch. e. Replace the regulator.
	Overexcitation circuit is shutting off regulator	Stop the prime mover and then restart (watch for high voltage).
Voltage builds and then decays.	Open the external voltage adjust potentiometer connected across terminals 6 and 7.	Replace the external voltage adjust potentiometer or the jumper across terminals 6 and 7.
	Defective regulator	Replace the regulator
Voltage does not build to rated value.	Terminals CB+ and CB- are not jumpered.	Install jumper across terminals CB+ and CB-.
	Wrong sensing tap selected.	Check sensing tap.
	Internal or external voltage adjustments are improperly set.	Adjust the front panel VOLT control and/or external voltage adjust potentiometer.
	Faulty regulator	Replace the regulator
Voltage high and uncontrollable	No sensing input	Verify wiring
	Wrong sensing tap	Check sensing tap
	Faulty regulator	Replace the regulator.
Generator response too slow or is hunting (oscillating).	Improper front panel STAB adjustment	Readjust front panel STAB control.
	Faulty regulator	Replace the regulator.
Poor regulation	Field resistance not matched to regulator capability or the regulator output rating is too low for the generator requirements.	Verify specifications
	Incorrect jumper selection for 50 or 60 Hz operation	Check for improper frequency jumper installation
	Low prime mover speed	Verify prime mover speed

This page intentionally left blank.

 **Basler Electric**
ROUTE 143, BOX 269
HIGHLAND, IL 62249 USA
<http://www.basler.com>, info@basler.com

PHONE +1 618-654-2341

FAX +1 618-654-2351