

**AN OVERVIEW OF GEAR MANUFACTURING PROCESSES**

## AN OVERVIEW OF GEAR MANUFACTURING PROCESSES

Gear manufacturing has been one of the most complicated of the metal cutting processes. From the beginning of the century, the demand for better productivity of gear manufacturing equipment was posed by “The Machines that changed the World” i.e. AUTOMOBILES.

### GEARS IN AUTOMOBILE TRANSMISSIONS

A gear box transmits the engine power to the driving wheels with the help of different gearing systems. Different gear combinations are used to give the smooth running, the lower fuel consumption, and the optimum driving comfort. Generally, passenger car transmissions are provided with 4-5 forward speeds and one reverse speed. In front wheel models, hypoid gears have been replaced by helical gears. Fig. 4.1 shows a typical transaxle of front drive model. Involute splines, both external and internal, are also widely used on various shafts and hubs for slide meshings in transmission system. Bevel gear and pinion are still used in differential of automobiles. However, parallel axes spur and helical gears are the main gears in automotive transmission. Manufacturing of gears presents a demanding challenge for metallurgists in heat treatment, for supervisors in machining and gear cutting, and for quality engineers in keeping the quality to the required standards.

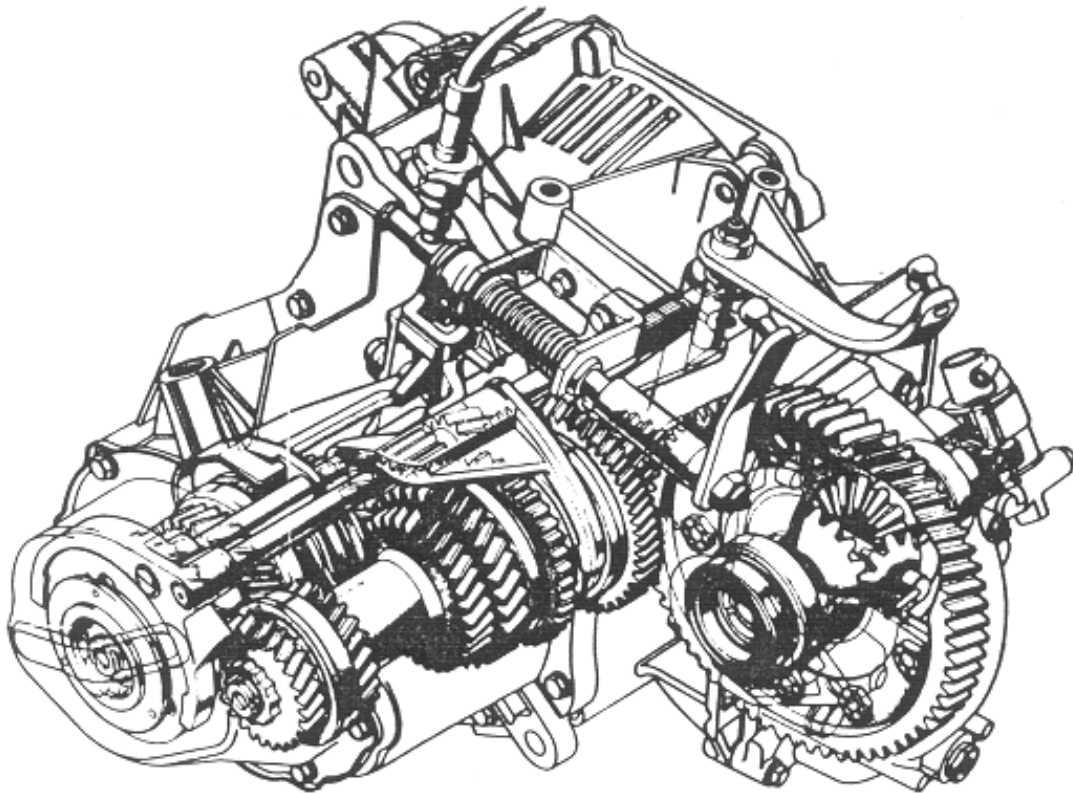

Fig. 4.1 A Typical Transaxle of a Modern Passenger Car

Gear manufacturing process dynamics are undergoing a major breakthrough in last two decades. Solutions being sought are not corrective but preventative. Normally, either soft gear process dynamic or hard gear process dynamic is being aimed. Objective is to cut the number of operations or machines through which a work gear needs to pass to attain the final specifications of dimensions and tooth form quality.

In soft gear process dynamic, the gear teeth are generated by gear hobbing or shaping depending on the component design constraints. Soft finishing of gear teeth is carried out by gear shaving, rolling or grinding to attain the gear quality grade. Even after the heat treatment deterioration, the quality specification remains well within the desired final specification to meet product final performance requirements such as noise, etc.

In hard gear process dynamic, hobbled and/or shaped, or warm forged/rolled gears after heat treatment undergo final finishing operation, such as hard finishing, honing, or grinding. Overall economy becomes the deciding factor for selection of the process dynamic.

### GEAR QUALITY AND MANUFACTURING PROCESSES

The functional necessity of a gear pair defines the limits of the deviations of all gear specifications. Gear quality refers to these permissible limits of deviations. Gear quality grades are standardised for different normal module/DP ranges and different ranges of reference diameters in AGMA, DIN, JIS and other standards. AGMA provides 8 grades from 15 to 8, where the higher grade number indicates the better gear accuracy. In DIN and JIS, a lower grade number means better gear accuracy.

Manufacturing processes used to produce finished gear specifications have certain capability limitations. Machine, work fixture, cutter, arbor, machined blanks, and also the cutting parameters add some amount of errors to different gear elements. Stages of manufacturing processes are to be accordingly decided. Fig. 4.2 gives a guideline for the capability of different manufacturing processes in terms of achievable quality grade requirements.

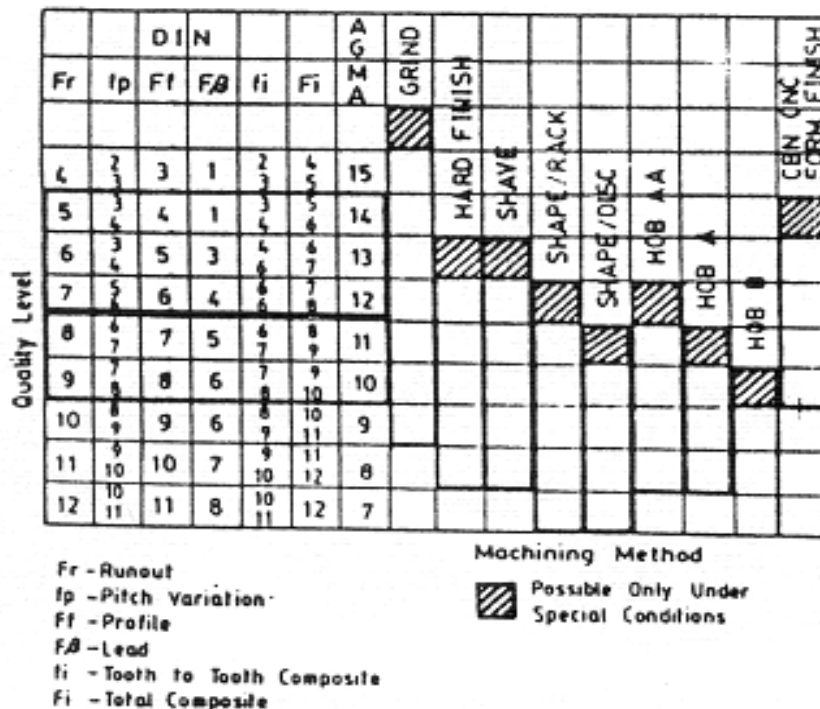

Fig. 4.2 Process Capability of Different Gear Manufacturing Processes  
 RAW MATERIALS FOR TRANSMISSION GEARS

Gears are generally designed for a finite life. Alloy steels are most favoured gear material. Case hardening steels provide the ideal features required for gear material. For gear teeth,

the surface is to be hard with soft and tough core to provide wear and fatigue resistance. Case hardening steels do have varying chemical composition, and are named accordingly, e.g. Chrome Steel, Low molybdenum steel, Chrome molybdenum steel, Nickel-chrome-molybdenum steel.

Basic requirements of good gear materials may be summarised as follows:

1. Well controlled hardenability, that helps in getting consistent and predictable result after heat treatment. Hardenability is the property of a steel that determines the depth and distribution of the hardness induced by quenching.
2. Least non-metallic inclusions especially oxides that generally present machining difficulties.
3. Good formability for better forge die life and consistency of forge quality.
4. High and consistent machinability.
5. Low and stabilised quenching distortion.
6. No grain growth during present practice of high temperature carburising, which can cause higher quenching distortion and lower toughness.

During recent years significant progress has been made in production of steels ideally required for gear. Gear steels are being developed to have totally controlled hardenability reducing distortion or making it accurately predictable and repeatable. With improved steel making processes, chemical compositions are being established to reduce inter-granular oxidation. Toughness and fatigue strength are getting improved dramatically. All these are through the improved steel manufacturing technology - especially the development of secondary refining (vacuum degassing and ladle refining applying arc heating) and related techniques.

## **BASIC FORMING PROCESSES**

Hot forging is most commonly used for gears. Maximum and highly uniform density is ensured by complete filling of forging die. During forging or upsetting, material grain is made to flow at right angle to the direction of the stress on gear teeth in actual dynamic loading. Uniform grain flow also reduces distortion during heat treatment. Generally shaft gears are upset. Even roll forging is used for cluster gears for high productivity. Cold/warm formings are high production though capital intensive methods used presently to produce gear blanks with much better dimensional control and about 20% material saving. Parts are formed without flash or mismatch. Draft angles are held to 1/2 degree on long parts and concentricity upto about 1 mm.

A good forging is a necessity. With faulty forging, no amount of excellence of design and care in manufacturing of gears from the best available material can ensure production of good quality gears. Machinability, ultimate strength, final quenching distortion, and surface finish will all be affected by the forging practices.

New cold forging methods produce a neat finished gear profile combining forming with rolling. Differential gears of automotive transmission are being commercially produced with neat tooth forms. Even, the gear teeth of spiral bevel gears are reported to be formed by plastic deformation of induction heated bevel gear blank using tooth rolling tool. The process produces a very high tooth finish, and results in a lot of material saving. On a larger gear, depending on application, a finishing operation of hobbing or grinding may be necessary with

a material stock removal of 0.4 mm-0.8 mm on tooth flanks. Cold rolling is already practiced for high speed production of splines and serrations with many built-in advantages.

## GEAR BLANK MACHINING

Quality of gear manufacturing starts with blank machining. Accuracy in blank machining is a necessity for attaining the desired quality standard of finished gears. According to shape, the gears are called **round gears** and **shaft gears**.

For round gears, the dimensional and/or inter-related tolerances that must be closely controlled are as follows :

- Size of the bore (inside diameter).
- Out of roundness or straightness of bore.
- Squareness of the bore axis with respect to face.
- Parallelism of the two faces.
- Outside diameter and runout with respect to bore.

Different defects in blank machining and their effects in subsequent gear manufacturing are:

1. **Oversize bore** results in poor clamping efficiency of the gear. Even a slight tendency to slip on the work holding arbour may cause lead error.

**Geometrical error of the bore** also results in poor work holding efficiency.

2. **Error in perpendicularity** of the bore axis with respect to the locating face, results in lead error and variation in lead.
3. Excessive **parallelity error** of work clamping face with respect to work locating surfaces, results in non uniform clamping and may twist the blank. In stack hobbing (when numbers of blanks are placed one over the other and are cut simultaneously), it causes lead error.
4. Excessive eccentricity of the outside diameter with respect to bore results in uneven cutting load and causes varying tooth depth around the periphery.

Round gear blanks are machined generally in two setups on many types of chucking lathes. Three-operation blank finishing ensures clean outside diameter. Two-operation finishing leaves a step on outside diameter. However, with accuracy of present work holding chucks, the amount is well within a limit that does not cause any trouble for ultimate performance.

For shaft gears, the axis of rotation is created by a face milling and centring operations on both the ends. The accuracy of the operation is important to maintain accuracy in the subsequent operations. Generally a protected type centre drill is used to avoid damage to the actual locating surface of the centre during handling. Shaft gears blank machining requires careful planning to achieve the concentricity between different locating surfaces and gear diameters. The tailstock pressure and the cutting forces may bend the shaft depending upon the length/diameter ratio, that may necessitate a judicious application of well-designed steady rest.

## GEAR MANUFACTURING PROCESSES - IN GENERAL

Gear manufacturing processes can be grouped in two categories. Category one relates to teeth cutting, finishing and all necessary operations related to gear tooth profiles, such as hobbing, shaping, shaving, honing, etc. Category two relates to the rest of the conventional machining, such as, drilling, milling, grinding, etc.

## GEAR CUTTING

Gear hobbing and shaping are the most commonly used cutting processes used for generating the gear teeth. Basis for selection of either of the two depends on application:

### COMPARISON OF PROCESS CAPABILITIES OF HOBGING & SHAPING

Features	Hobbing	Shaping
Accuracy	Better with respect to tooth spacing and runout. Equal so far lead accuracy is required.	Better w.r.t. tooth form.
Surface finish	Hobbing produces a series of radial flats based on feed rate of hob across the work.	Shaping produces a series of straight lines parallel to the axis of the gear. As the stroking rate can be varied independently of rotary feed, the numbers of enveloping cuts are essentially more than the same for a hobbed gear. Surface finish may be better.
Versatility	Can not be used for internal gears. Hob diameter determines the limitation of cutting gear with shoulder.	Can be used for internal gears  Can cut upto shoulder with very little clearance.
Limitation	For helical gears, only differential gearing is used which again can be eliminated in CNC hobbing Faster for gears with larger face width.	Each helix and hand requires a separate helical guide. No CNC system to replace helical guide is still developed. Time cycle will be 2-3 times of hobbing for wider gears.
Production rate	Stacking can make hobbing faster than shaping even for gears with narrow face widths.	With high speed stroking, narrow width job can be finished in lesser time than by hobbing.

## GEAR SHAPING

In the 'molding generating' process of gear shaping (Fig. 4.3), a gear of desired tooth profile with cutting capability can generate the similar tooth profile in a blank and produce a gear suitable for meshing with any gear of interchangeable series. The cutter with a particular

number of teeth on its periphery rotates in the correct ratio required for generating the desired number of teeth on the rotating blank.

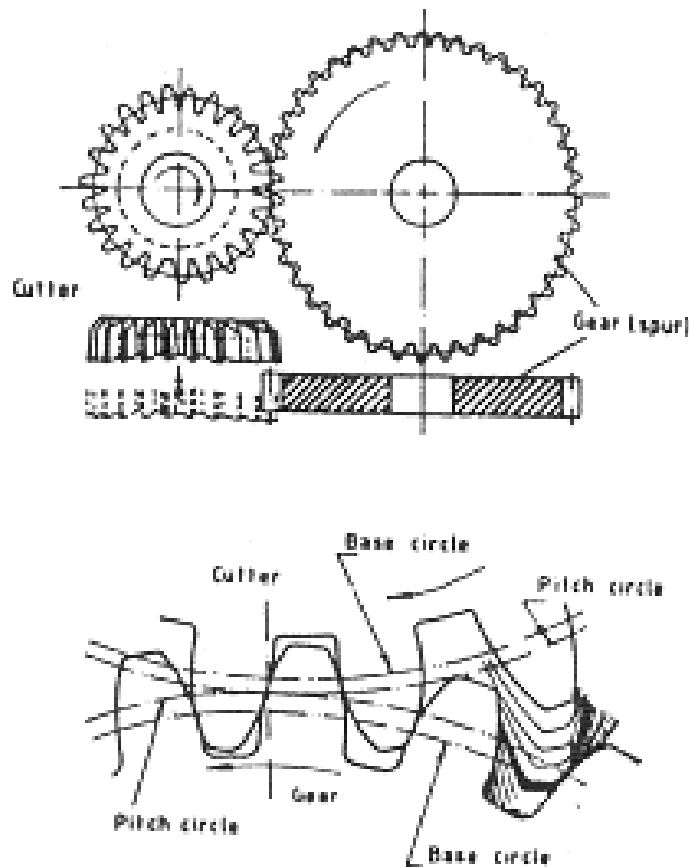

Fig. 4.3 Molding Generating Process of Gear Shaping

The rotations of the cutter and the workgear are in opposite direction for external gear and in same direction for internal gear. The cutter simultaneously reciprocates parallel to the tooth profile of the workgear. The distance between the cutter and workgear axes gradually reduces till the final size (pitch circle diameter) of the gear being generated is reached. Cutting may occur in downward stroke or in upward stroke. When cutting occurs in downward stroke, it is called down cutting or push shaping. When cutting occurs in upward stroke, it is termed as up cutting or pull shaping.

### Machine Features

Over the years mechanical linkages have been gradually simplified reducing the effect of play and backlash in linkages. Machine structure has been improved to provide better static and dynamic rigidity and to dampen vibration originating from reciprocating cutter spindle and intermittent impact load at the start of each cutting stroke.

**Cutter Head:** An electro-mechanical or hydro-mechanical system provides the reciprocating motion to the cutter spindle. In most of the modern gear shaper, Fig. 4.4, a directly driven

crankshaft links the cutter head with a connecting rod. In a hydro-mechanical system, Fig. 4.5, a servomotor drives the stroking linkage with provisions for adjustments for setting stroke length and appropriate quick return speeds. During the cutting stroke, the hydraulic pressure is directed to the large area of the spindle piston. The return force is applied on the small area of the spindle and thus accelerates the spindle to higher velocity during return stroke.

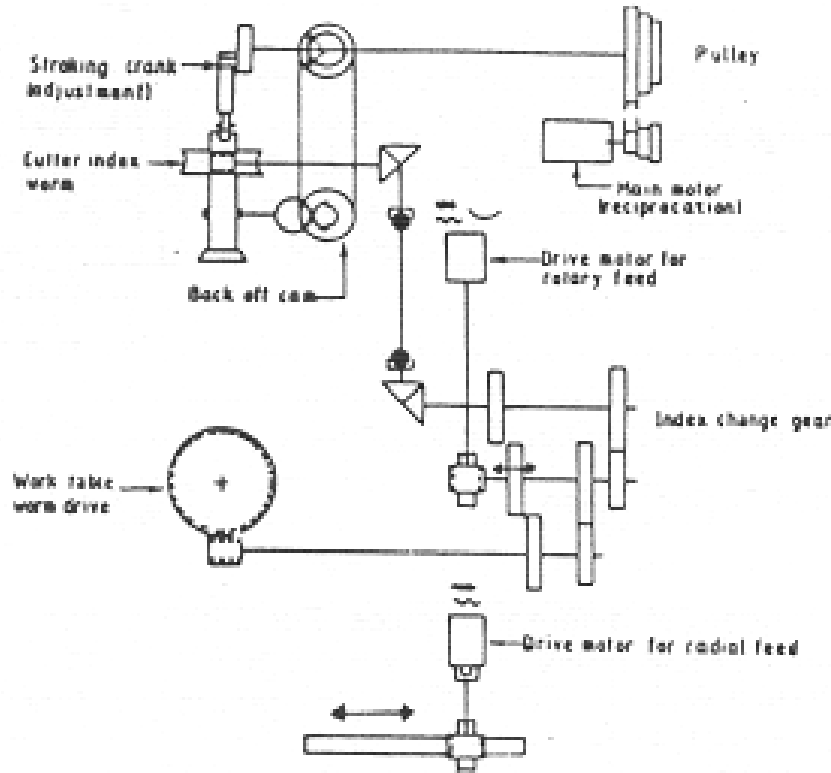

**Fig. 4.4 A Second Generation Modern Gear Shaping Machine**

The cutting force is concentric with the cutter spindle axis. High inertia of rotating or reciprocating parts is eliminated in hydromechanical system. In hydro-mechanical system of stroking, one cycle of the cutter spindle may use the cutting stroke at a lower velocity and the return stroke at a higher velocity. The cycle time is reduced. Hydromechanical system provides advantages for gears with wider faces (above 38 mm). However, the faster return stroke facilities are also available on machines with mechanical reciprocating system. In one system non-circular gears on the countershaft drive provide accelerated speed on the return stroke of the cutter spindle. In another system, this is accomplished by a special drive with a twin crank, Fig. 4.6.

**Cutter Head and Guide :** An accurate index worm and worm gear drive unit with closely controlled backlash rotates the cutter head. A guide is essential to provide the compound motion of the cutter head. For a spur gear, a straight guide positively aligns the cutter, and



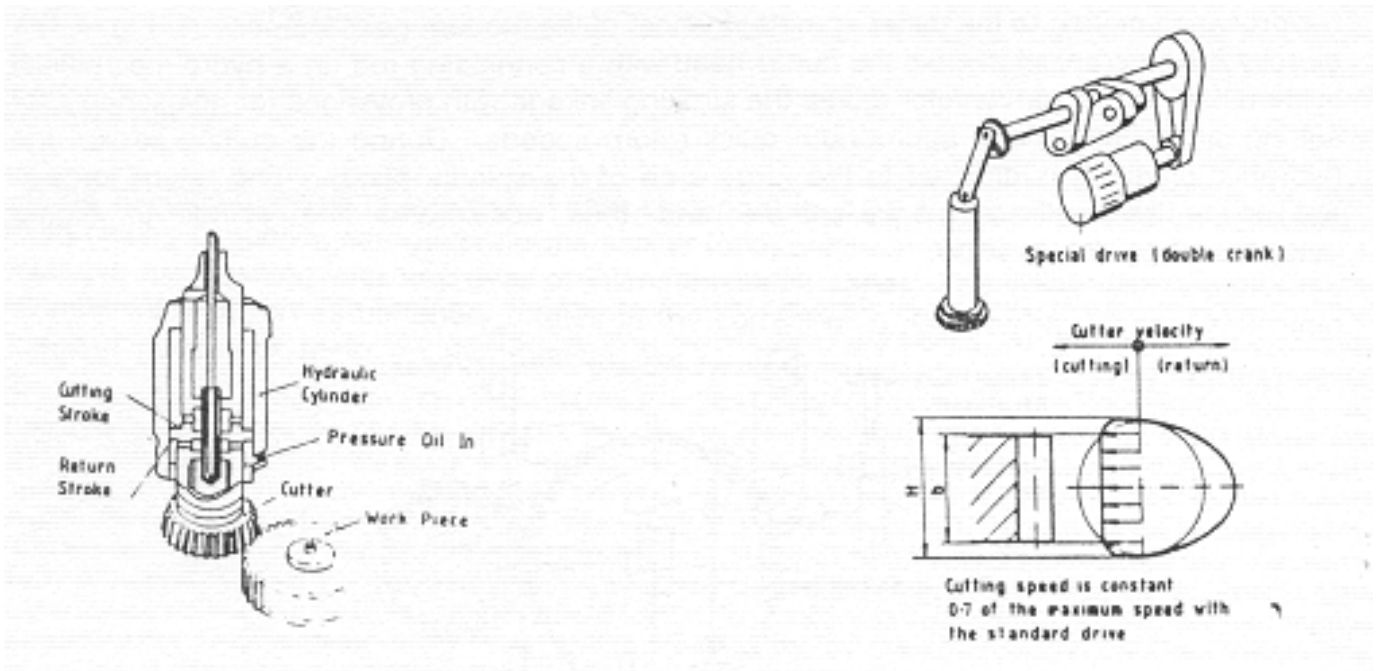

Fig. 4.5 Hydraulic-added Reciprocation System

Fig. 4.6 Double Crank Stroking System

remains same for spur gears of different modules. For a helical gear, a helical guide, Fig. 4.7, imparts the twisting motion to the cutter as it reciprocates and rotates. For generating helical gears with different module and helix angle, generally different helical guides are required.

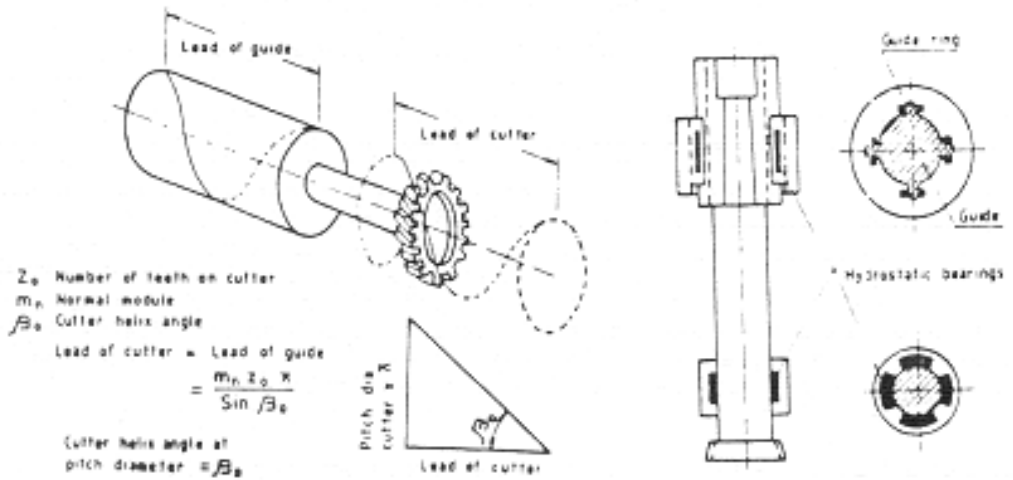

Fig. 4.7 Principle of Helical Lead Guide

Fig. 4.8 A Hydrostatic Guide of Gear shaper

Almost all modern gear shapers are provided with hydrostatic bearings for guides, Fig. 4.8. A constant presence of a film of lubrication oil at about 60 bar pressure between the flanks is ensured. The possibility of wear is eliminated. The stroking rate can be increased even beyond 2000 strokes per minute. Even the extreme condition of high helix shaping does not present any trouble in operation. The diameter of the guide is kept large enough to withstand all torsional stresses generated in shaping. The hydrostatic bearing aligns the spindle and directs the cutter stiffly during cutting to attain an excellent tooth alignment tolerance. Pitch and base tangent tolerances of DIN class 6 are achievable on modern gear shapers. Almost all the modern gear shaping machines provide the back-off relief to the cutter spindle to avoid cutter interference. The cutter spindle backs off radially from the workpiece during the non-cutting return stroke.

Permissible radial and axial runout of the cutter mounting are within 0.005 mm (or better). With increasing trend for large diameter disc cutters, a lapped rear face of the cutter supports upto the extreme outside diameter to eliminate any possibility of deflection at very high cutting load. Automatic clamping system in the shaper spindle allows the use of preset shaper cutter. Fig. 4.9 shows a semi-automatic quick cutter clamping system for a modern gear shaping machine.

**Work Table:** The thrust load in shaping is taken on a wide peripheral area of the table. The ratio of the indexing worm wheel diameter to the maximum workgear diameter that can be shaped on the machine is kept high (above 1.5). High precision dual lead worms are used.

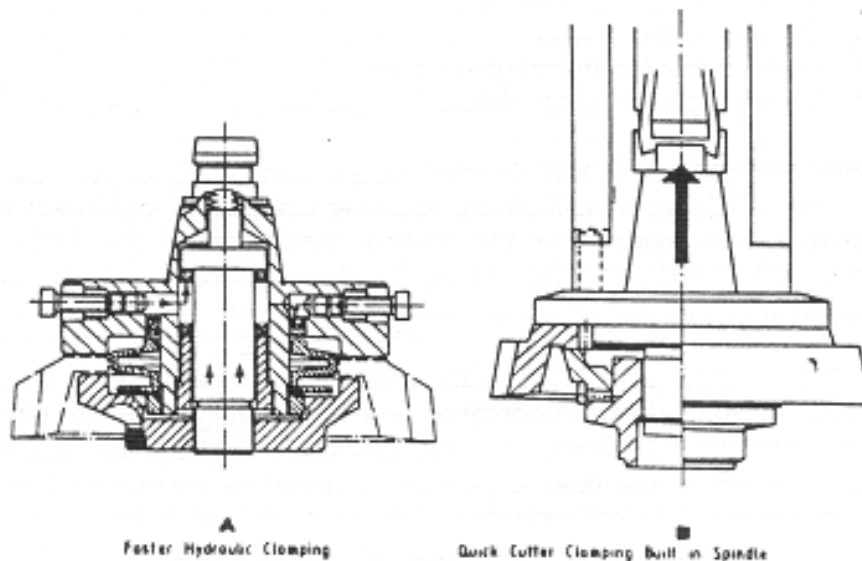

Fig. 4.9 A Semi-Automatic Quick Cutter Clamping System

Play on the flanks is kept constant by adjusting the backlash, when necessary. The accuracy of the worms and wheel drives of the indexing system is the deciding factor for the machining

accuracy of gear shaping. The work spindle or arbor used for work holding must run true within 5 micron or better.

**Drive System Connecting Cutter Head to Work table:** Index change gears maintain the required relationship of the rotation of cutter spindle and worktable that holds the workgear. In second generation machine, kinematics has undergone a major change mainly with fewer, short and torsionally stiff gear-trains. Separate motors of infinitely variable speed are used for reciprocation speed, rotary feed and radial feed. Desired combination of reciprocation rate with rotary and radial feed is possible to achieve better productivity and tool life. Ease of setting has been the main objective. Even on conventional machines, the replacement of change gears today is very easy in comparison with earlier models. For the same spindle size, the overall weight of the machine has increased by 2-3 times. The machines with more power and rigidity permit the very high cutting parameters that have greatly improved the productivity.

### **Latest Gear Shapers with CNC**

A full CNC gear shaper incorporated the electronic gear box in the late eighties. Index change gear trains disappeared. The elimination of gear trains also reduced and eliminated the inaccuracy caused by torsional windup of gearing system. DC/AC servo motors drive the different axes. A total CNC gear shaper Fig. 4.10, has separate drives for :

1. Reciprocation with dead centre positioning - S axis.
2. Radial motion - X axis.
3. Rotation of cutter - D axis
4. Rotation of workgear - C axis
5. Stroke position - Z axis
6. Stroke length - V axis
7. Offset cutter head/workgear - Y axis
8. Relief angle for taper - B axis.

Each numerically controlled axis has its own independent drive as well as own position measuring system. CNC has simplified the machine kinematics. However, CNC machine requires (a) high quality guide ways for precise positioning of the individual axes by traversing without stick slip, and (b) thermal and mechanical stability for better and consistent accuracy..

The guiding motion to cutter spindle for attaining the desired lead on the gear being cut is still beyond CNC. Helical guides for generating gears of varying leads are different and are to be changed manually. Japanese builders exhibited an attempt to provide a CNC controlled guiding motion, where helix angle can be varied as desired for the cutter in use. However, the system is yet to be perfected. Solution to this problem must be one of the important projects for research engineers working on gear shaping.

### **Infeed Methods in Gear Shaping**

Proper combination of rotary feed and radial infeed decides the type of chip formation and chip flow in gear shaping process. It affects the tool wear rate and pattern as well as the

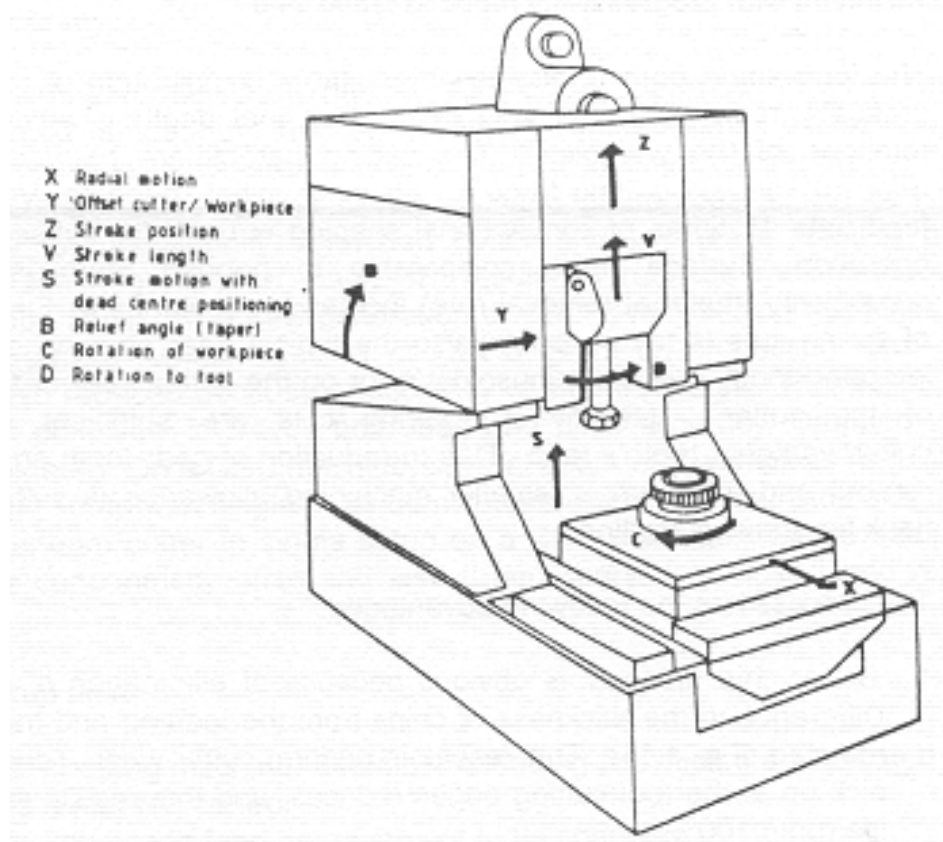

Fig. 4.10 A Total CNC Gear Shaper

productivity of the operation. Some improved methods of infeed used in gear shaping are as follows:

**1. Plunge feed during rotation**

Radial infeed to the required depth to attain the desired size of the gear occurs simultaneously with rotation of the cutter and workpiece. A comparatively short spiral path within the range of feeds is used. Triple flank chips, Fig. 4.11a, are produced and chip crowding is critical.

**2. Spiral infeed with constant radial feed**

A continuous radial infeed at constant rate is applied till the required depth is reached. The shaping cycle requires several work rotations to complete the operation. The long spiral path is attained by suitable combination of rotary feeds with radial feeds. The machine must have capability to combine extremely high rates of rotary feed with extremely low rates of radial infeed. The method produces thin chips at the tip and thick chips at the flanks, Fig. 4.11b. Chip formation and flow can be modified for better productivity and surface finish by varying the ratio of rotary to radial feed.

### 3. Spiral infeed with progressively reduced radial feed

The long spiral path is attained by suitable combination of rotary feed with gradually reducing radial feed rate. The final depth is attained in several rotations of the workpiece. The cutting parameters help controlled stock removal keeping cutting force constant for initial roughing. Very high rotary feed upto 15 times of conventional shaping is used for subsequent finishing operation. Surface finish comparable to hobbed teeth is possible. The productivity (material removal rate) increases substantially. Finally, a number of spring cuts is taken to minimise the typical gear shaping errors, such as 'dropped tooth' due to a sinusoidal error on the cutter itself or faulty mounting of the cutter. Usually 2-3 spring cuts are sufficient depending on cutter/workgear teeth's ratio. Due to reduction of gear tooth errors, e.g. radial run-out and pitch errors, smaller machining allowance is sufficient on tooth flank for shaving / rolling.

The process has the following advantages :

1. Better chip disposal is obvious because of elimination of chip crowding. Difference in the thickness of chips from the leading and trailing flanks is reduced, Fig. 4.11c. This results in uniform cutter wear. Tendency of cutter pick up at the tool cutting edges reduces, and this results in better tool life (upto 100%).
2. Cutting time is considerably reduced (25%-100%).
3. Overall quality of gears and surface finish is improved. (about one grade, say, to 7-8 as against 8-9 through conventional infeed system, as per DIN 3962.)

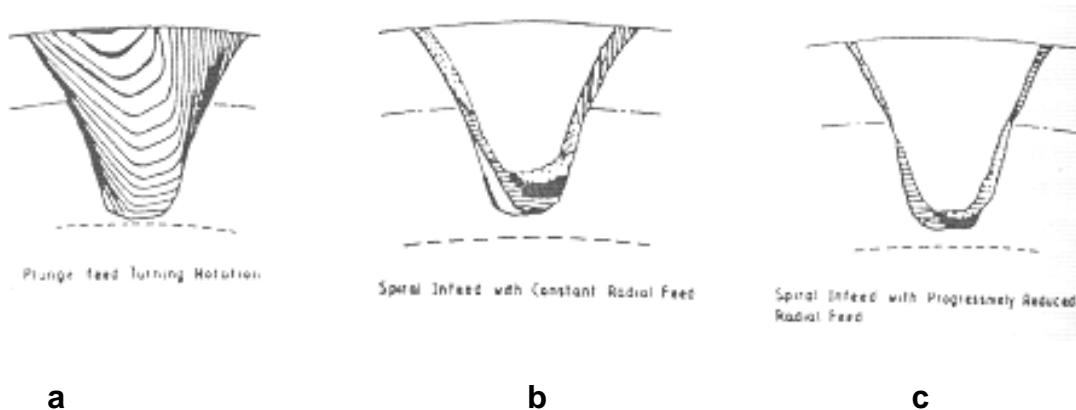

Fig 4.11 Different Infeed Methods and Chip formations in Gear Shaping

## **Advantages of CNC Gear Shaping Machines**

### **1. Improved accuracy**

Highly accurate linear measuring permits very close tolerance on size. On some machines, machine-mounted temperature and displacement sensors detect dimensional variations in the machine structure due to variations in operating or ambient temperatures. The control system automatically compensates for the deviations, and guarantees almost constant size of gears produced in a lot. Individually controlled cutter and workpiece rotation permit best cutting parameters at finish generation stage. It results in reduced radial runout, pitch error, and improved surface finish. The new generation of CNC gear shaping machines are claimed to be capable of producing AGMA class 11 or DIN 6 gears on production runs. Minimum shoulder clearance is also reduced because of accuracy of stroke reversal. This makes a compact design possible. CNC positively improves both lead and pitch accuracy. Dropped tooth condition can almost be eliminated. On a CNC machine, several gears of a workpiece (e.g. cluster gear) can be shaped in single setup with single or tandem cutters. Similarly, an inside and outside gear can be finished with tandem cutter in single setup on a CNC machine. Single setup shaping naturally ensures better concentricity error and also if necessary very close timed relation between the gears.

### **2. Reduced setup time**

On a CNC gear shaping machine, a number of setting activities are eliminated depending on number of axes under NC control -

1. Index and feed gears are not to be changed.
2. Stroke positioning/stroke length is not to be set.
3. Rapid motion and feed distances of the radial traverse (worktable or cutter column) are not to be adjusted manually.
4. Radial feed is not to be adjusted and set for multi-cut cycle.
5. Cutter spindle stroking speed is not to be set.
6. Direction of cutter relieving from external gear cutting is not to be changed for upcutting or for cutting internal gear.

On CNC machines, normal setup changeover may be completed within 10 minutes.

### **3. Reduced Cycle Time :**

On CNC machine, the cycle time is reduced because of two main reasons:

1. All rapid traverses can be set more accurately because of linear transducers on slides.
2. Best possible combination of stroking speed, rotary feed and radial infeed reduces the cycle time to minimum.

Cycle time for a typical gear has come down to less than a minute on a modern CNC machine from about 4 minutes on conventional gear shapers.

## **Machine Configurations**

## 1. Vertical or Horizontal

Generally, all modern gear shaping machines are with vertical cutter spindle. However, a machine builder offers one horizontal shaping machines with provision for simultaneous shaping of more than one gear/spline portion. Fig. 4.12 shows a multi-cutter spline shaping of an automobile mainshaft. Three cutters on left side and one on right side shapes four spline portions simultaneously.

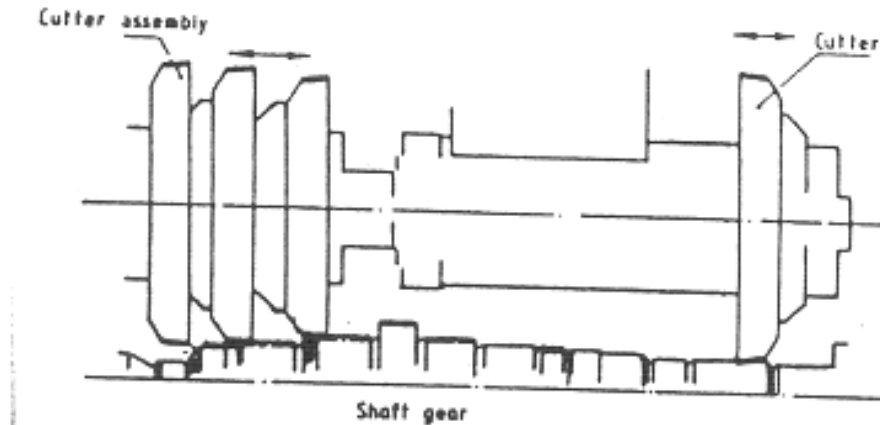

Fig. 4.12 A Horizontal Multi-Cutter Shaping Operation

## 2. Column moving or table moving machine

For production application, preference is given for a column moving machine, where the machine column with cutter slide moves in and away in relation to the stationary worktable. It provides the advantage of fixing up automatic loading and unloading arrangement.

## 3. Table tilting or column tilting for taper shaping

The synchronising gear teeth in automobile transmission are designed with slight taper to avoid the automatic loss of engagement of involute splines (trouble known as 'gear jumping'). Some special configurations of shaping machines (Fig. 4.13) are as follows:

1. Suitable tapered riserblock is used to tilt the machine column to specified angle of taper. The machine does not provide for any change of taper angle unless the machine is reassembled with different taper riser block.
2. A tilting machine column allows to cut gears parallel to the axis as well as with a back taper within a range.
3. A tilting worktable is used on a standard machine. The table may be dedicated for an amount of taper or may have provision for changing the tilt angle within a range.

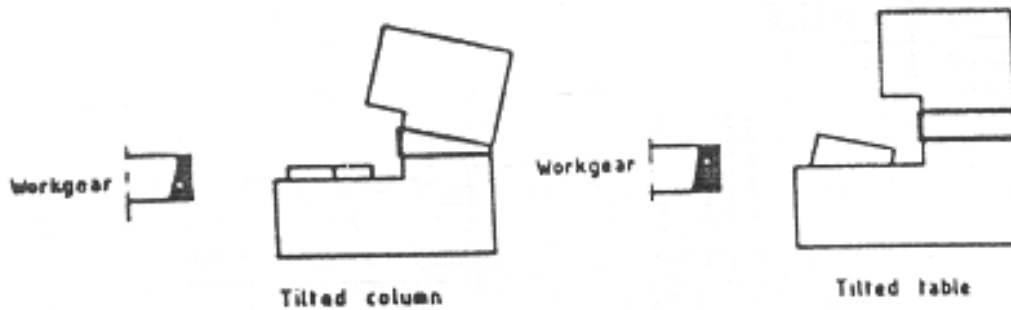

Fig. 4.13 Machine Configurations for Taper Shaping

### Applications

A special application problem of gear shaping for an automobile main gear is shown in Fig. 4.14, where the space limitation of component design does not permit the use of an external cutter. A shank type cutter with very small number of teeth can be used. However, the cutter will not have the rigidity and strength required for high speed shaping. Production efficiency will be extremely low as well as cutter edge wear will be faster with very low tool life. An internal shaper cutter Fig. 4.15, though costly, will be rigid enough for high speed shaping but with limitation of chip disposal.

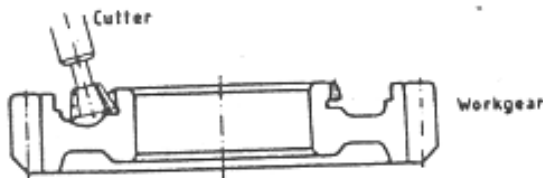

Fig. 4.14 Shaping In Space Constraint

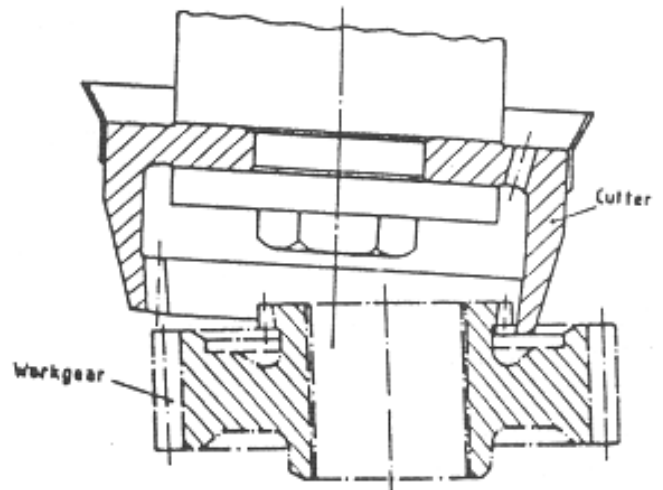

Fig. 4.15 Internal Type Of Cutter

Fig. 4.16 shows two setups where multi-gear shaping is possible on CNC machine using one tandem (A) and the other single cutter (B). In setup I, the two cutters mounted in tandem shape the 3 helical gears of a cluster gear. As the helix angle and module of 2 gears are same, the same cutter can generate both the gears. The second cutter of different reference diameter shapes the other helical gear of different helix angle and module, but with the same helical guide in single setup operation. In setup II, one cutter shapes two spur gears of a transmission mainshaft with different number of teeth.



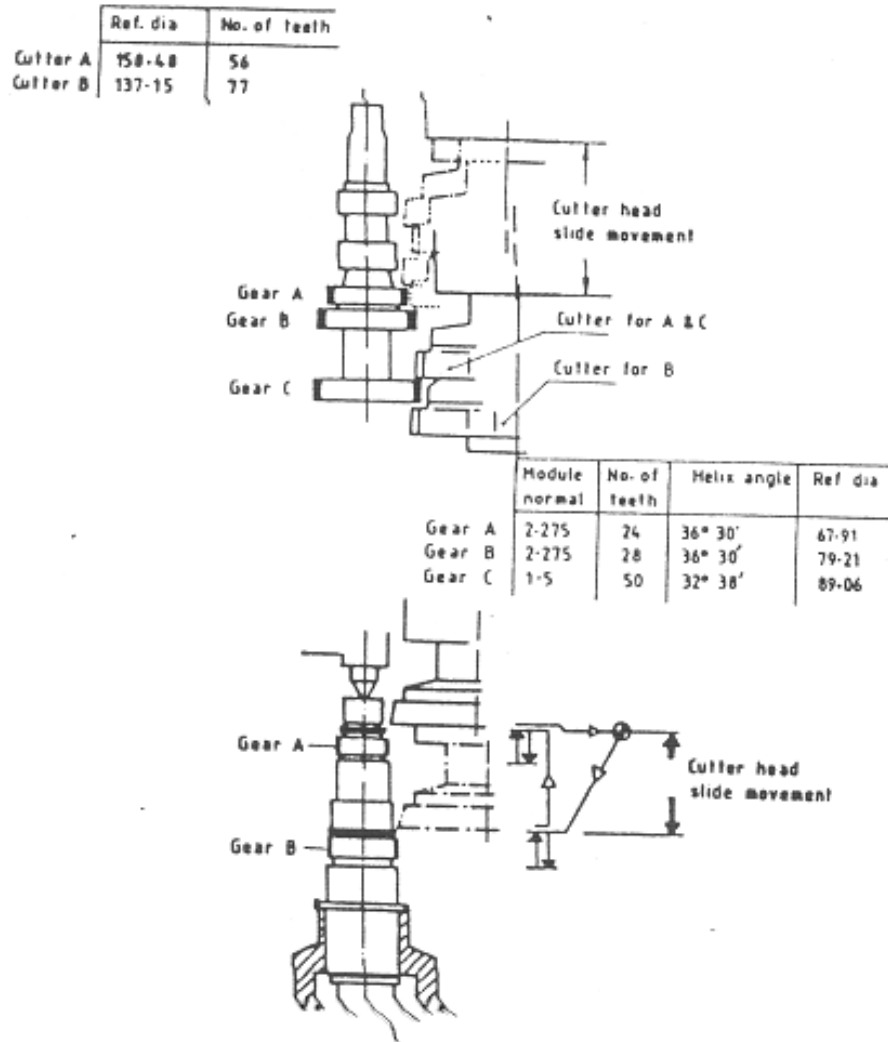

Fig. 4.16 Multi-Gear Shaping in Single Setup

Fig. 4.17 shows a tandem cutter setup for 'push' and 'pull' shaping in single setup. Two straight gears of a planetary pinion with different number of teeth are being shaped in single setup. A tooth space in gear 1 is to have an exactly specified position in relation to a tooth space in gear 2. Two cutters bolted back to back with the required tooth alignment are mounted on one cutter adapter. It eliminates all errors of location and clamping of two-setup shaping.

## GEAR HOBGING

In hobbing, a worm like cutter known as 'hob' with cutting teeth having the basic reference profile of a rack cuts teeth on a cylindrical blank. Successive hob teeth come in contact with each tooth in the gear blank and generate gear tooth by producing a large number of flats that envelop the tooth profiles, Fig. 4.18. Hob is tilted according to the hob thread angle and helix angle on the gear teeth, to align the hob teeth with the teeth of the gear to be cut. A single thread hob generates one tooth space in one turn of its rotation. The hob and the blank rotate in a constant timed relation to each other that depends on the number of thread of the hob and the number of teeth on the workgear. The hob moves radially to the desired

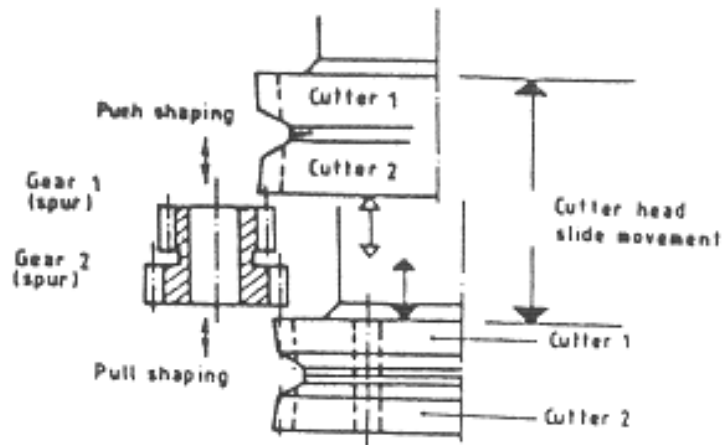

Fig. 4.17 Push and Pull Shaping in Single setup

depth of the teeth a little clear from the blank and then feeds axially along the width of the gear teeth.

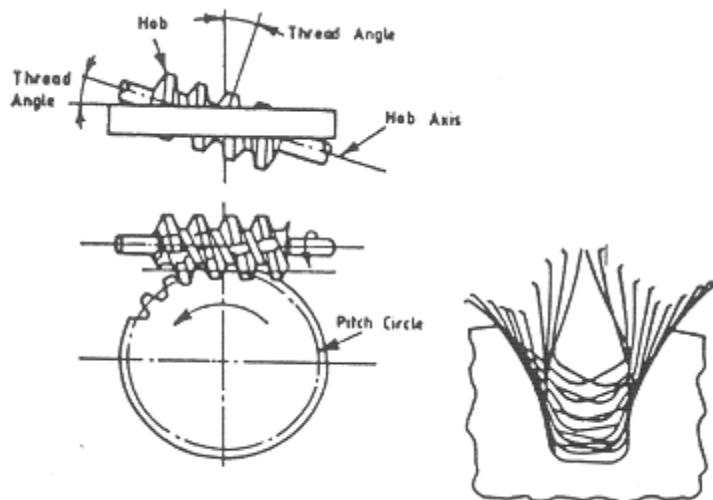

Fig. 4.18 Generating Process and Enveloping Cuts in Hobbing

#### Machine Elements of Hobbers:

**Change gears and differential system:** Conventional mechanical hobbing machine uses index change gears, and feed change gears to maintain the proper constant timed relationship between the revolution of the hob and the worktable. Unlike gear shaping of helical gear with the help of special helical guide, the helix angle in hobbing is attained by advancing or retarding the relative rotation of hob and the gear blank. A differential system affects the rotation of the workgear and correlates the feed motion through a separate change gear system (known as differential change gears) for obtaining the correct lead. The differential imparts slight supplemental increment or decrement motion of the worktable independent of index change gears and feed change gears.

**Hob Head and Cutter Spindle:** Cutter spindle holds the hob arbor and ensures that the hob arbor and cutter assembly run true on its own axis during cutting. Cutter spindle mounted on

a swivelling head is tilted to bring the hob teeth in line with gear teeth. Hob head swivel angle depends on the hand and amount of the lead angle of hob and the hand and amount of helix angle of the workgear. When the hand of hob is same as the hand of the workgear, it is known as 'Same hand hobbing'. Cutting force in 'same hand hobbing' will have a component opposing to workpiece rotation. When the hand of hob is the opposite to that of workgear, it is termed as 'Reverse hand hobbing'. Cutting force in 'reverse hand hobbing' will have a component in same direction of workpiece rotation, Fig. 4.19.

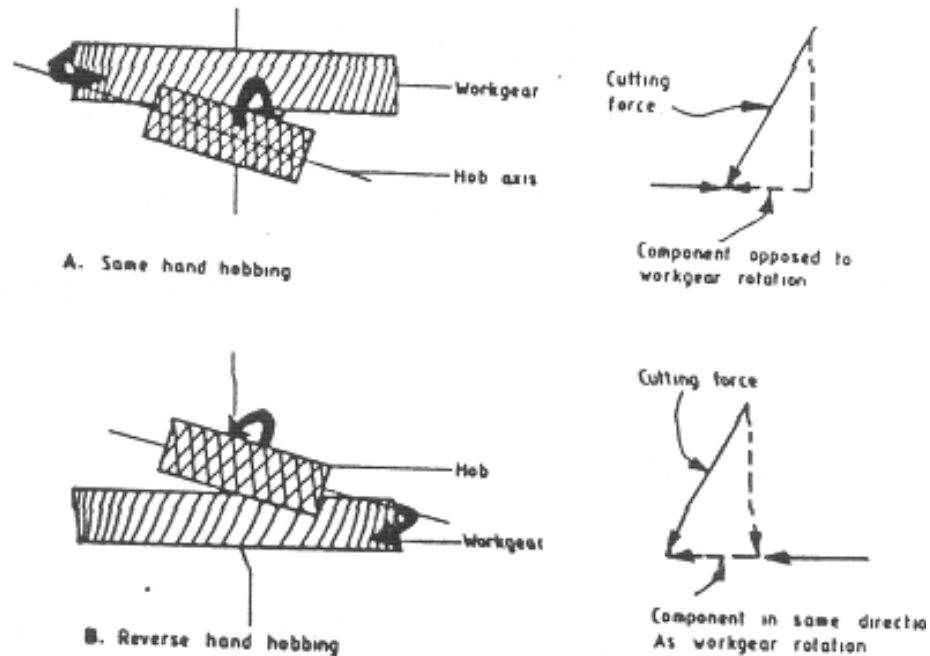

Fig. 4.19 Same Hand Hobbing and Reverse Hand Hobbing

**Hob mounting:** Run-out on the face and the outside diameter of the hob arbor is held within a close limit. The taper bore of the cutter spindle and taper of hob arbor must be clean. The arbor is pulled tightly into the taper bore of the cutter spindle to rest against shoulder. Most of the cutting torque is transmitted by friction via the taper connection. Even an extremely thin oil film in taper (such as one due to wiping off with a greasy hand) will destroy the self locking friction. For a well-held hob, the bending resistance will primarily depend on the diameter of the spacing collars and not on that of the hob arbor. Errors in hob mounting (angularity, eccentricity and axial run-out) result in different inaccuracies in profile generated, Fig. 4.20 and influence the gear quality significantly.

**Hob feed direction:** Generally the radial feed is provided by moving the cutter head towards the work table. The hob head moves axially to complete the cutting of the gear teeth along the face of the gear. Direction of travel of hob head-slide decides cutting method. In climb hobbing, Fig. 4.21, the hob pulls itself into the work with maximum chip depth at start and zero chip depth at exit. In conventional hobbing, Fig. 4.22, the condition is just opposite. It starts with very little cut and removes the maximum width at exit. The cutting edge of a dull

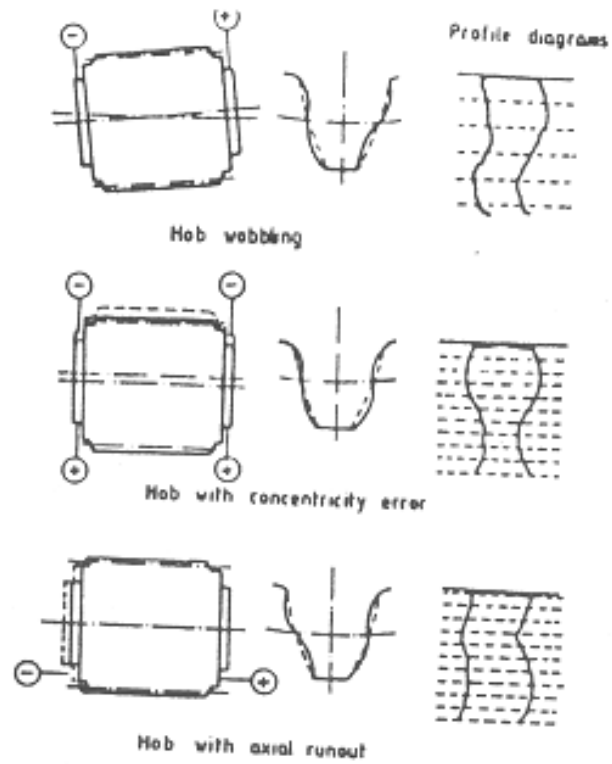

Fig. 4.20 Inaccuracies in Profiles Generated Due to Incorrect Hob Mounting

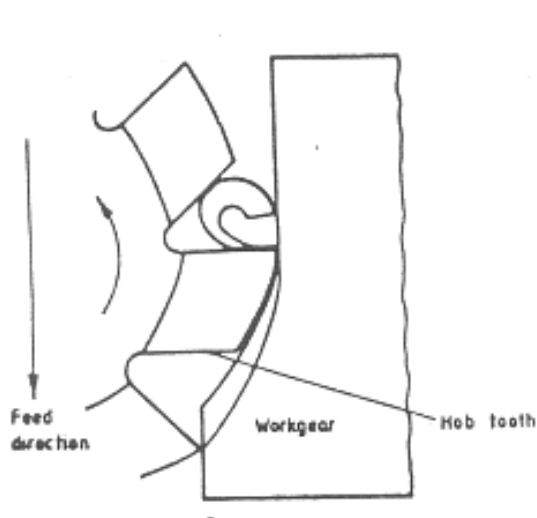

Fig. 4.21 Climb Hobbing

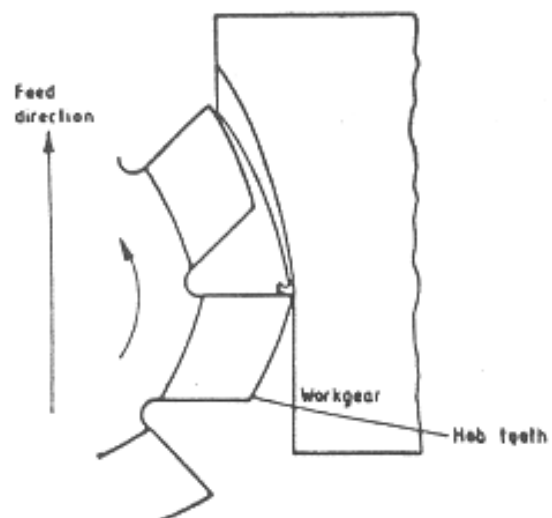

Fig 4.22 Conventional Hobbing

hob tends to slide along over the material, squeezes and hardens the surface that deteriorates the cutting conditions. So the conventional hobbing may result in smoothing effect.

Advantages of climb hobbing:

- Higher cutting parameters are used and so the productivity is higher.
- One-cut hobbing will be sufficient when the conventional hobbing may require two cuts for similar results with same cutting parameters.

Limitations of climb hobbing:

- Poor surface finish.
- The machine requires good maintenance with minimum play in moving parts and feed mechanism.

Actual application decides the method of hobbing - climb, conventional, or a combination of both in two cut method. For high helix workgear, the conventional hobbing is superior because of better hob entrance conditions. Rough cutting by climb hobbing results frequently in higher lead error and poorer surface finish. A roughing cut by conventional method may follow a finishing operation by climb hobbing to produce the desired quality on the gear being cut. For very coarse pitch gears, the conventional hobbing is preferred because of less tendency of chatter. In conventional hobbing of spur gear, entrance angle is small. In climb hobbing, entrance angle is larger. All the cutting edges cut into the surface of outer circle. Hob life is better in conventional hobbing. Naturally, material, amount of stock, helix angle, setup and machine condition decide the method.

Hand of hob cutter and work gear helix along with the direction of axial feed determines the chip formation and cutting performances of the hobbing process. Normally, for mass production of helical gears, the same hand climb hobbing is practised. However, the Japanese researchers have established that conventional hobbing with a reverse handed hob is more effective for comparatively small module gears of automotive transmission for high speed manufacturing. The entrance angle is large and chip length per blade is short. Hob life is far better. Direction of cutting force against gear blank coincides with direction of table rotation. So the machine must have very effective backlash eliminator. It is also established that gear accuracy (tooth profile error and lead error) in the reverse hand conventional hobbing is superior to that in the same hand climb hobbing.

**Hobbing cycle:** Hob can be fed radially, axially and tangentially to complete the cutting of the total width of the gear depending on specific constraints. Various types of hobbing cycles, as shown in Fig. 4.23, are used on the basis of application.

**Work Table and its Drive Systems:** Work table is mounted on large bearing surface to improve the damping against the intermittent cutting action of a hob. A worm wheel of a size bigger than maximum size of gear to be hobbled drives the work table on the machine. Accuracy of the worm wheel and worm of the table drive is extremely important for the accuracy of the gear to be cut. Mr. A. Sykes of David Brown Industries has explained this aspect in his book 'Gear Hobbing and Shaving', *'.....to assist in preserving overall accuracy, ....the intermediate gears between the hob spindle and the master worm should run at the highest practical speed, .... the effective error produced in the work by an intermediate gear is in general, inversely proportional to its running speed..... because the magnitude of the error is a smaller percentage of the table angular movement of that gear in a given period of*

*time*'. Worm wheel and worm are the slowest moving elements and so affect primarily the accuracy of the work gear. Cyclical transmission error is the deviation of the actual rotational ratio of the work table and the hob spindle from the desired rotational ratio. Cyclic transmission error consists of **high frequency error** (that is caused by transmission error of the gear train primarily that of the index worm) and **low frequency error** (that is the error per one revolution of worm gear driving the worktable). DIN 8642 establishes the value of high frequency and low frequency errors.

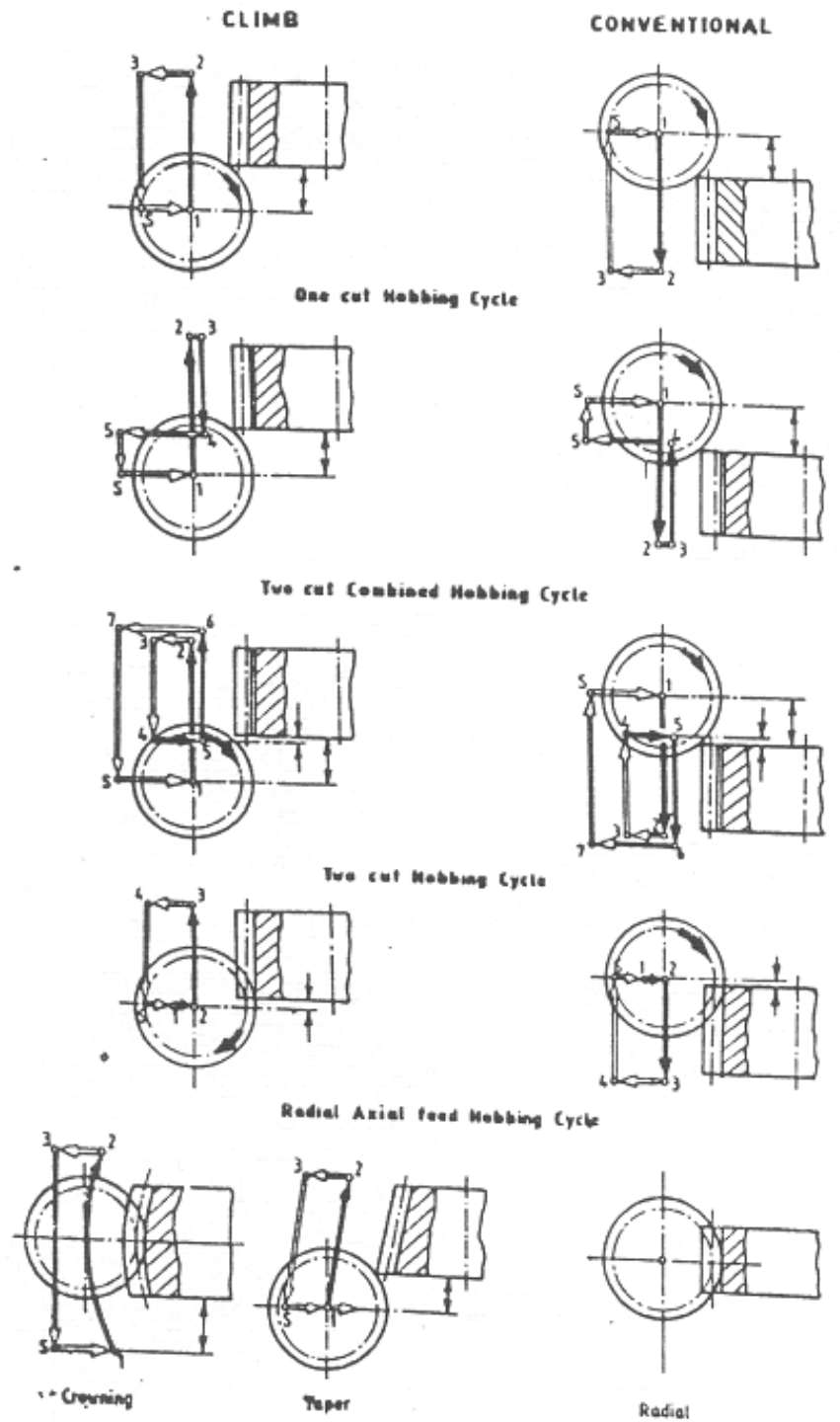

Fig. 4.23 Different Hobbing Cycles for Different Applications

It is necessary to know the accuracy level of the machine in use to determine the achievable accuracy of the work gear. Work piece tooth spacing error depends on:

- Number of teeth being cut.
- Number of teeth in worm gear of the hobbing machine.
- High frequency error of the machine.

The kinematic accuracy of the worm and worm wheel is assured by new method of high precision manufacturing and checking. Backlash is kept minimum and is closely maintained

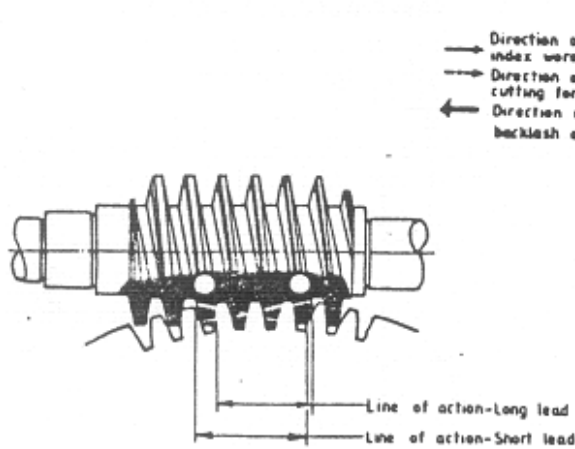

Fig. 4.24 Duplex Worm Drive

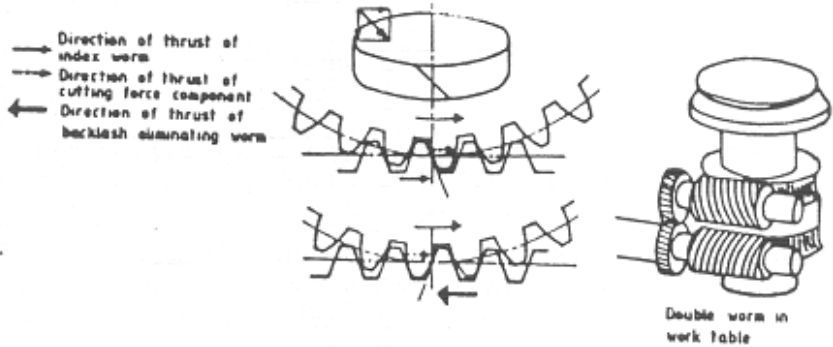

Fig. 4.25 Double Worm in Work Table

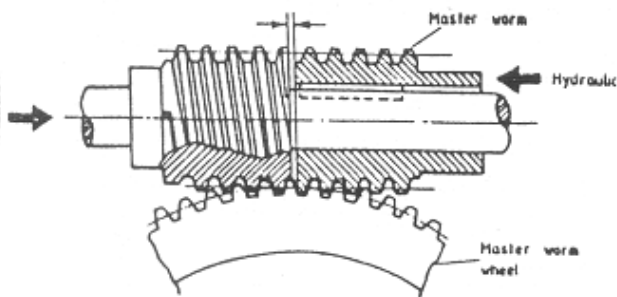

Fig. 4.26 Split Master Worm Gear

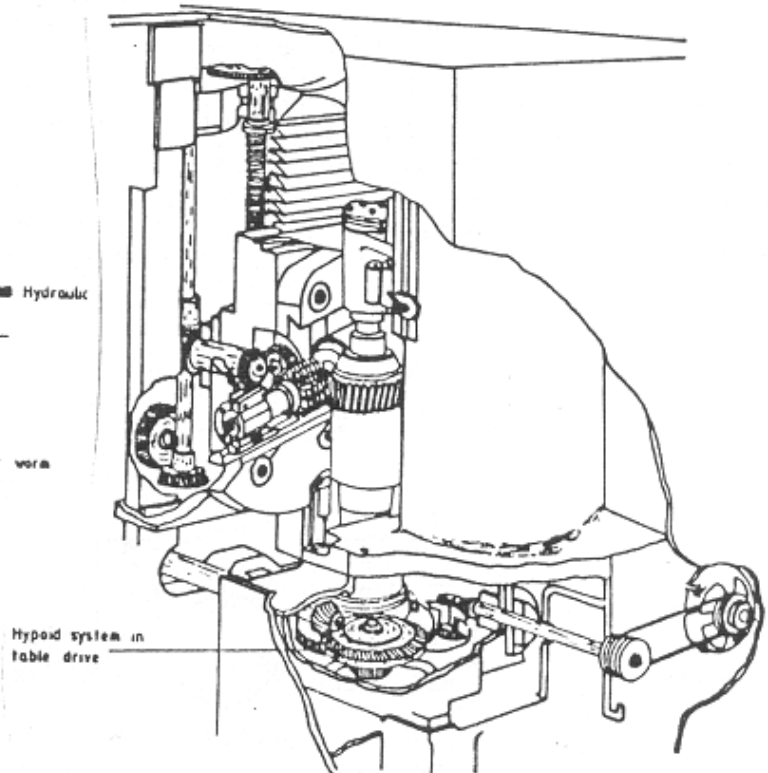

Fig. 4.27 Hypoid system in Table Drive

with periodic adjustment. Special wear resistant materials are used and the system operates in oil bath. Moreover, earlier standard worm drive has been replaced by special designs, such as one shown in Fig. 4.24 with high contact ratio results in low specific load. The design permits backlash adjustment without altering centre distance. In a further improvement, double worms on a worm gear, Fig. 4.25 are employed. One worm is hydraulically counter-loaded against the action of the driving worm to effectively remove the backlash. It certainly reduces the effect of hob entering and exit conditions on the quality of the teeth generated. In yet another system, split master index worm (Fig. 4.26) is hydraulically preloaded to work as an adjustable backlash eliminator.

However, the manufacturing process used for worm/worm wheel for the machine has limitations regarding the achievable accuracy. It becomes more difficult when the worm is multithreaded one for higher worktable speed. A compromise between accuracy and stiffness of the gear train becomes necessary. Considering these limitations, a manufacturer in USA uses a hypoid drive system, Fig. 4.27. Both members of the hypoid gear set can be ground to much better accuracy. The design gives a stiffer drive train and greatly reduced total machine deflections. Entire drive train can be preloaded for reverse hand hobbing. The system generates less heat. Frequent table drive backlash adjustments are eliminated. It also provides a wide range of speed. Yet another manufacturer is using a highly accurate helical gear system in the worktable (Fig. 4.28). The table drive system is permanently backlash free via a torsion bar.

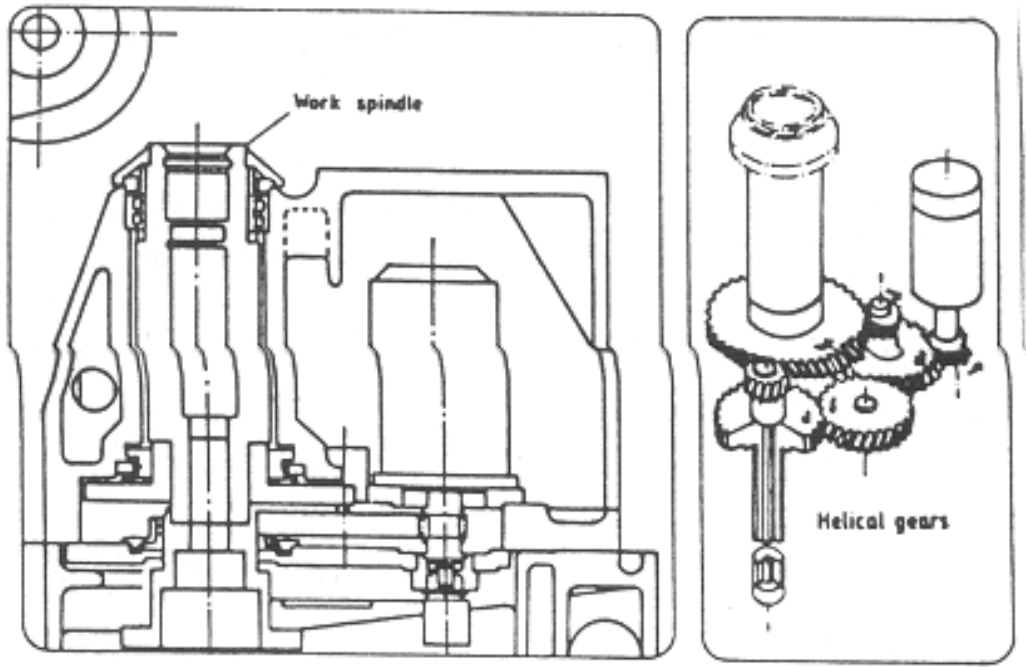

Fig. 4.28 Helical Gear System in Work table Drive Train

**High Speed Hobbing:** For better productivity, high speed hobbing becomes necessary. Over the years, the tool material properties have significantly improved. High speed steels manufactured through powder metallurgy processes are far better than conventional high speed steels used for hob. Surface treatment processes of hobs, e.g. Titanium Nitride coating by physical vapour deposition method, have been perfected. Cemented carbide hobs are



also commercially available. So higher cutting speeds in metre per minute, i.e. higher hob revolution per minute can be used to reduce hobbing time. Preference for smaller diameter hob also means higher rpm even for the same cutting speed. Multi-start hob, again, improves productivity. Even if the same hob rpm, the worktable revolution will increase in multiple of the number of start on the hob. The work table drive system must have higher rpm. As discussed, machine builders have incorporated multi-start worm or different gear systems to increase the speed range to the required level. High speed hobbing is a reality.

### **Developments in Hobbing Machines over Years:**

Developments over the years are interesting. Main spindle power has increased almost by 4 to 5 times, and the overall weight by almost 2 - 3 times. Many features have improved the rigidity and accuracy of the hobbing machines for working with very high cutting parameters:

- Computer aided design of machine frames provides high static and dynamic rigidity. Even with higher cutting feed at any point in the cutting cycle, the cutting edge of the hob remains in its correct momentary position relative to the workpiece. It results in more accurate gear with better accuracy of involute, spacing, lead, surface finish and also tool life.
- Higher transmission ratio between the hob spindle and the index drive worm ensures better kinematic accuracy.
- Elimination of the tie bar between the main column and tailstock has improved the effective damping of cutting vibrations.
- Reduction in hob overhang - the distance between the hob centre line and the column rails, correspondingly reduces lifting moment. Preloaded hob head drive maintains the conjugate tooth action even with heavily varying cutting forces. Fewer drive elements in hobhead have made it stiffer.
- Axial and radial guide ways are better structured, offer better weight control, and provide anti stick-slip properties. Some uses re-circulating needle blocks in hobslide guideways to move the slides completely free from backlash and looseness. It also compensates for wear automatically unlike the slide with tapered gibs, which are to be adjusted when clearance increases beyond the specified limit.
- Ball screws have proved to be superior to Acme lead screws and are preloaded for the concept of hobbing at faster rate.
- Thermal stability has been improved by various design concepts to ensure uniform temperature of coolant, lubricant and the machine structure.

Some additional features have improved the productivity of modern hobbing machines:

- Quick hob changing devices bring down the cutter change time almost to one minute. Hob runout is guaranteed within less than 0.01 mm. Hydraulic clamping device is much faster. Cutter with face key provides ease in its replacement. It is possible to fit this hob with one hand.
- Fixtures are designed with quick change-over concept. When a machine is used for a family of parts, exchange of relatively few add-on parts will only be required for the set up changeover. Fixture run-out is almost guaranteed. Usual time of fixture change has been reduced from 20-50 minutes to 5-10 minutes.

**Advent of CNC Hobbing Machine:** Automatic work cycle electro-hydraulic machines rely on electrically controlled and hydraulically or mechanically performed functions with proximity switches, cams, etc. With programmable logic controller, only cycle programming is done through console and electro-mechanical programming device. CNC control brought the real revolution of built-in flexibility. Various CNC axes, Fig. 4.29 and their functions are

- X- Variable radial feed, easy setting of depth of cut, precise positioning, close loop control of centre distance of hob and gear and thus over pin size.
- Y- Hob shifting rate and limits, memory function of the last position of hob before opening other set-up, with position shift possible to use multiple hobs to cut several kinds of gears
- Z- Variable axial feed.
- A- Hob head swivel positioning.
- B- Hob spindle variable speed and positioning for automatic hob change
- C- Table rotation speed variable and gear synchronised for accurate generation.

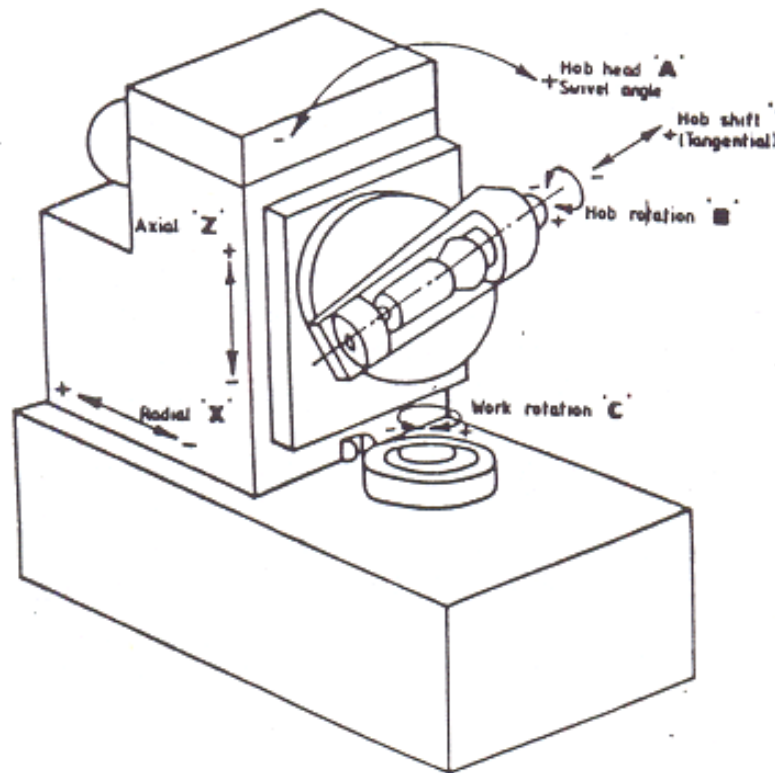

**Fig. 4.29 A Full CNC Hobbing Machine**

Today hobbing machines with CNC control of different number of axes are commercially available.. A total CNC machine incorporates electronic gear box. The individual drive motors and encoders are provided for all the functions along with the associated incremental measuring system. The CNC system provides a constant control of the axial position of the hobslide and a constant correction of the respective table rotation. The accuracy of the gear generated will depend upon the accuracy and speed of response of this synchronisation that is controlled through CNC control system. Any irregularity during one hob rotation in relation

with worktable will produce profile error. Any deviation of time from the theoretical time required for each hob rotation will result in lead error. The synchronising system through CNC control samples the variation of hob rpm of each rotation and provides compensation to the servo system of table index in advance to obtain correct synchronisation. Combination of feed-back and feed-forward control provide the desired synchronisation.

### **Advantages of CNC Hobbing Machines**

CNC enhances the capabilities of the hobbing machine to a great extent. No calculations are required. Infinite possibilities for the feed cycle with interpolation of various axes are available to achieve the design requirements and productivity improvements. Some advantageous possibilities are:

- Crowning or taper
- Skip hobbing
- Relief hobbing
- Single indexing
- Oblique hobbing
- Double helical gear hobbing in single setup
- Multiple gears (or splines) - different pitch, helix angle and number of teeth in single setup.
- Hobbing of non circular gears.

CNC improves the quality, reduces the setup time and also the cycle time.

### **Quality improvements**

1. The linear encoder, controlling the radial machine-slide is generally of a 1 micron resolution giving operational tolerance band of 4 microns. It means consistent over-pin size of gears produced. An integrated electronic centre distance correction is possible that ensures constant centre distance regardless of varying operating temperature.
2. In conventional hobbing, the tangential force slowly changes characteristics over the length of the axial travel, and results in a distortion of the entire differential train. It causes a continuous lead deviation from its specified value of the tooth generated. With replacement of mechanical gear train, these errors are eliminated and the stiffness of the entire system is increased giving better accuracy. Accuracy capability of CNC hobbing is AGMA-12, and that also because of the limitations arising out of hob lead accuracy in one revolution of the hob.
3. Hob 'break-outs' are infinitely less pronounced during hob entry and exit with programmed feed rate and improved kinematic accuracy.
4. Repeatability to hob a part exactly in an established manner each time is improved because of stored part programme.
5. For gear requiring crowning and taper, the quality is better as fixed templates that are prone to wear or wrong adjustment, are eliminated. Unfavourable dead point band at the highest point is totally absent.
6. Multiple gears on a shaft (e.g. cluster gears) can be hobbled in one clamping with single or with multiple cutters mounted on the same arbor, Fig. 4.30. This ensures better concentricity and if required, timed relations between the gears. Even a change from

hobbing to single index milling may be programmed for improved slot position with respect to gear tooth spacing, if required by designer for a component.

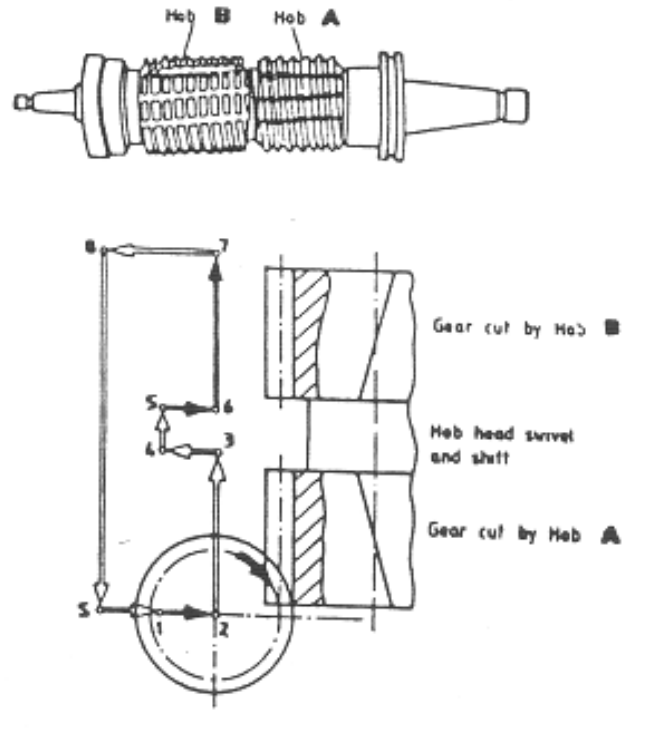

Fig. 4.30 Multiple Hobs for Multiple Gear Generation

### Reduced time cycle

1. Considerably reduced safety margins, i.e. reduced idle slide travels are possible as no mechanical / electrical dead stops, trip dogs and limit switches are in use. Hob is made to stop much closer before feed starts. So time cycle is reduced.
2. Higher feed rate at the time of hob entry and during the hob exit, Fig. 4.31 further helps in reduction of the machining time.
3. Simultaneous operation of several axes further reduces the time cycle e.g. fast return to cycle start position by shortest path, Fig. 4.32.

### Reduced setup time

In CNC hobbing machine, the setting activities have either been eliminated or reduced to a greater extent.

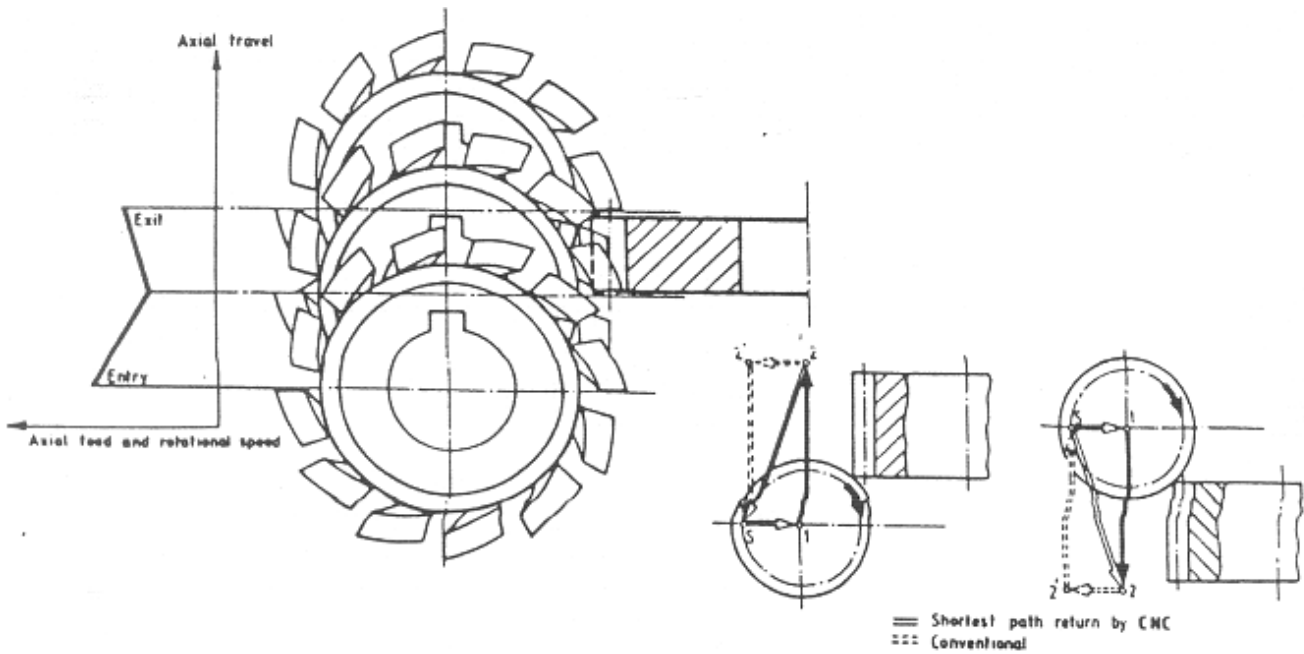

Fig. 4.31 Higher Entry and Exit feed and speed    Fig. 4.32 Reduced Unproductive time

**Some Hobbing Machines with Special Configurations**

1. **Diagonal Hobbing Machine:** A high production hobbing machine with oblique direction feeding (Fig. 4.33) is used specifically for single work cutting of flat type (with bore) spur and helical gears of automobile transmission. Differential gear mechanism is eliminated. Instead, helical gear cutting is affected by moving the hobhead in the oblique direction. The process claims better cutter utilisation, uniform wear of cutting edges and longer cutter life.

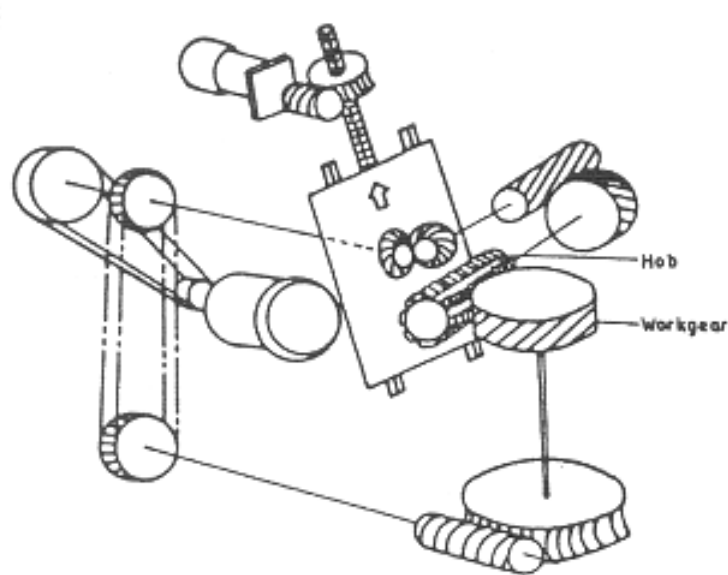

Fig. 4.33 Kinematics of a Oblique Hobbing Machine

2. **Horizontal spline hobbing machine** - For very long slender shaft, the horizontal configuration of hobbing machine is preferred with an obvious advantage for work loading and unloading.
3. **Combination of hobbing and shaping** - One European manufacturer has in its product programme a machine popularly known as 'Shobber' that is basically a hobbing machine with another unit for gear shaping, Fig. 4.34. Naturally, the machine will have certain limitation regarding versatility, but surely reduce machining time for some type of gear. On quality consideration, it will be possible to hold very close concentricity errors between two sets of teeth.

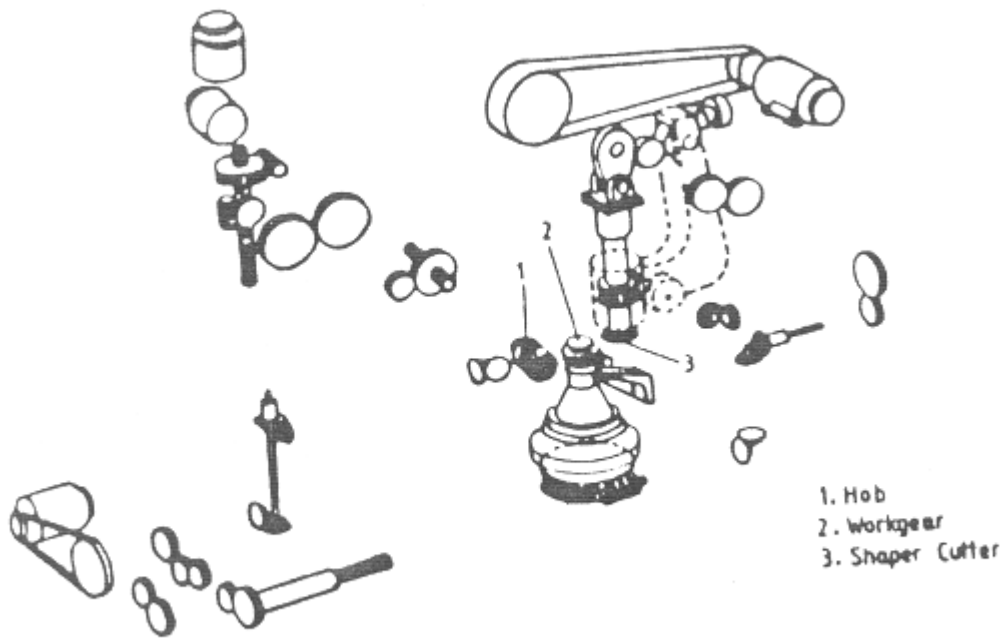

Fig. 4.34 Kinematics of a 'Shobber' Machine- a Combination of Shaping & Hobbing

Some special high speed gear cutting processes, as shown in Fig. 4.35, have also been used for cutting the gear teeth in automobile industry:

1. **Broaching - external (Pot)** is a special high production machining process. The tool with internal tooth configurations (held in a 'pot') passes over a round part to produce external teeth in a single pass with production rate upto 500 parts/hour. Applying a twisting action either to the cutter or the work may enable broaching of helical gears.
2. **Shear speed process** is a spur gear cutting process. All the spaces of gear teeth on the periphery are cut simultaneously with formed cutting blades mounted in a special tool holder. Gear blank is clamped and remains stationary under a tool head. Each movement removes certain amount of each tooth depth. The blades are relieved a little on reaching the end of the stroke. The blades are fed inward additionally through a double cone unit in

tool head for the next working stroke. The process repeats till finish size is achieved. At the end of the cycle, all blades are moved to the exterior starting position by an upward motion of the double cone unit.

- G.Trac generation:** A continuous chain of tool blocks with large number of cutting blades is run across the face of a rotating workpiece. In one model with one row of cutter blades, the work is fed into the cutter blades and rolled as though in mesh with a single tooth simulated by the single row of cutter blades. After one tooth space is generated, the work is withdrawn, indexed to the next tooth space and fed in again, and so on till all the teeth are completed. For high production model, a work piece is fed against a number of rows of cutter blades on the blocks on chain and revolved continuously until all teeth are finished. The process is 6 to 10 times faster than hobbing.

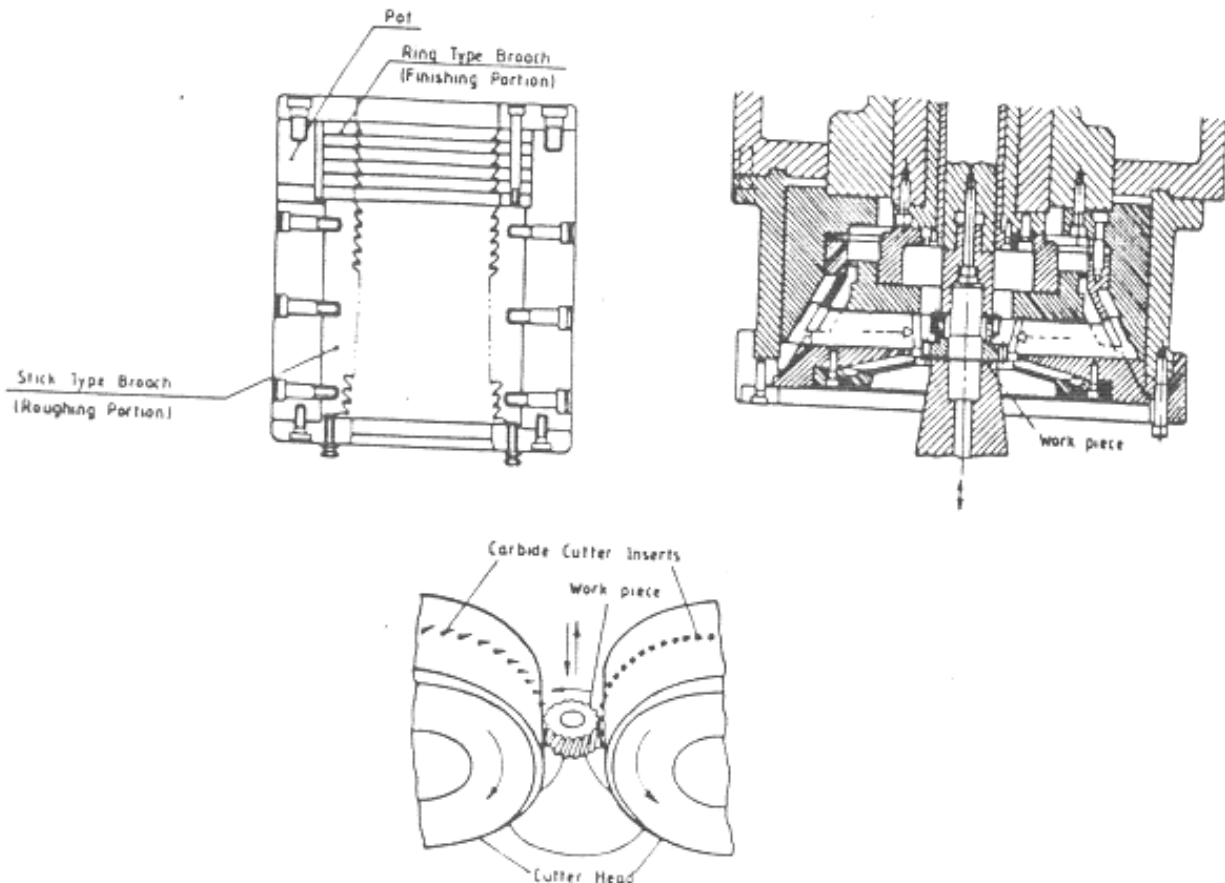

Fig. 4.35 Some Special Gear Cutting Methods

## EDGE FINISHING

During shaping and hobbing, burrs appear at the exit side of the cutter. Process sequence, tool design, tool replacement frequency and cutting parameters are some of the major factors that decide the type and strength of the burr produced. Minimisation of burr and placing them in the best position for easy removal is the main target of a manufacturing engineer. Deburring may seem to be a simple operation to start with, but it is really difficult, particularly so in gear manufacturing. When the burr is being removed from one side it tries to move in a

different direction. As a principle, deburring must be carried out just after the operation where the burrs have been generated.

Along with the chances of injury in manual handling, the presence of burrs may damage the tooth surfaces during transportation and produce nicks. Mostly these nicks are created on the gear teeth by the sharp edges of gears themselves from accidental hits during in-process handling. These nicks cause meshing defects and are observed as sudden and very high deviation of profile or lead during double flank roll testing. Percentage rejection of gears because of nicks varies between 10% - 60% depending on sophistication in handling provided and care taken to minimise the collisions. Again, the sharp edges tend to become super-carburised during heat treatment. Because of excessive brittleness, these edges break off and cause further harmful damages (or noise problems) during actual operation in transmission. Fig. 4.36 shows the different chamferings of a gear tooth, that are essential to protect the active flanks of gear tooth from damages.

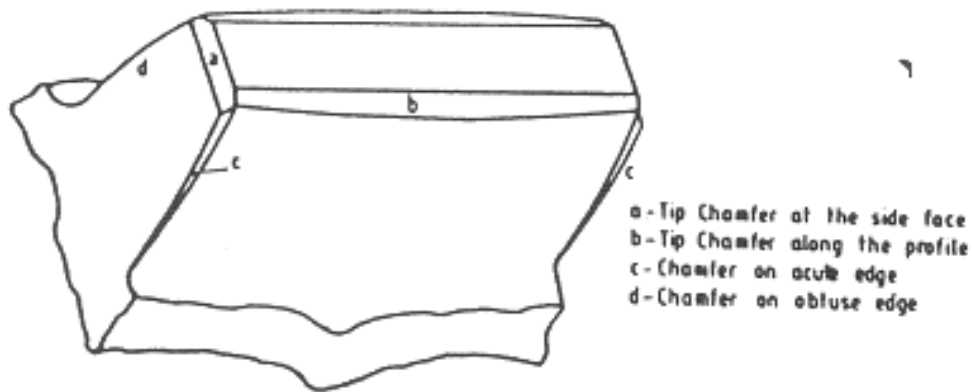

**Fig. 4.36 Different Protective Chamferings on a Gear Tooth**

Deburring removes burrs as well as produces a control-sized chamfer. The tip chamfer 'b' along the profile is produced with modified tooth profile of the hob or gear shaping cutter (semi-topping). Size of chamfer depends on gear module. Angle of chamfer may vary from 30 degrees to 45 degrees, and the amount may be from 0.10m to 0.15m (m is the module of the gear). For gears of less than 1.25 module, the use of topping cutters may be recommended (with an allowance of 0.5-0.8 mm on outside diameter of turned blank). Topping cutter finishes the outside diameter along with chamfer. The chamfers, 'c' on the acute and 'd' on the obtuse edges, are necessary for the helical gear-tooth. Sometimes, the roots of the teeth are also to be chamfered.

### **Rotary chamfering and deburring**

Rotary chamfering and deburring machine produces different forms of chamfer, Fig. 4.37:



- a. Chamfering of only one flank without that of root
- b. Chamfering of both the flanks without that of root
- c. Chamfering of one flank with part of root
- d. Chamfering of complete profile.



**Fig. 4.37 Different Chamfer Forms by Rotary Chamfering and Deburring**

In this process, the tool comprising of two chamfering discs (with bevel gear like teeth) meshes with the gear. The gear drives the tool assembly. The chamfering discs are designed according to the module and helix angle of the gear and according to the chamfer form desired. The chamfer is generated by rolling/cutting of the edges of the gear teeth. The secondary burr developed at the gear faces may be removed by deburring discs/ tools

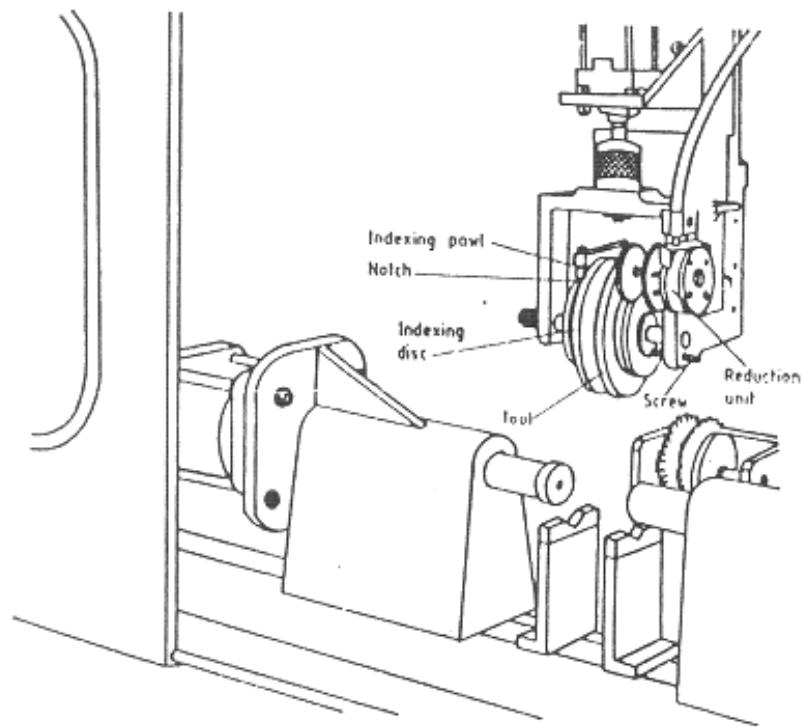

**Fig. 4.38 A Rotary Deburring and Chamfering Setup**

assembled on the same head along with chamfering tools. The system is used efficiently for spur as well as helical gears. It is also possible to deburr a gear with a synchroniser if a minimum gap (about 3 to 4 mm) is available between the main gear and synchroniser. The same chamfering and deburring machine may be used for chamfering of large variety of gears, as the process is extremely fast. Again the same machine may be used for shaft gears as well as round gears with bore. The shaft gears are held between centres. For round gears, suitable locating arbors are used. Fig. 4.38 shows a rotary chamfering and deburring setup.

## Pointing

Tooth pointing is carried out on the end faces of external and internal teeth of spur gear or spline to aid in smooth entry while gear changing in transmission. Different forms of pointing, Fig. 4.39, are specified to take care of easy entrance of the external synchronizing teeth in internal splines of sliding sleeves depending on the load condition. These operations are carried out on tooth pointing machines (also known as chamfering machines). Various configurations of these machines are in use. The workspindle of a chamfering machine can have a continuous rotation indexing or an index plate-controlled intermittent indexing. Indexing may also be performed by a pulse motor, where change-over for different number of teeth becomes very easy. Work clamping device, e.g. collet or fixture, is mounted on the workspindle with a facility for providing correct relation of the teeth with respect to the cutter spindle to ensure uniform material removal. Generally either a fixed or retractable (swivelling or sliding type) work locators are used. On machine with single spindle, after one side of the chamfer is generated, the cutter head will have to be reset for the other side of the chamfer. Twin spindle machines generate the chamfers on both sides in one cycle. The workpiece remains stationary and the rotating cutters get fed axially into the tooth space in rapid advance, feed dwell and rapid return mode. The workpiece is indexed by one tooth space when the cutter slide is in its rear position. The same cycle is repeated. The form of pointing is established by the type of cutters, along with the vertical and angular setting of the cutter heads.

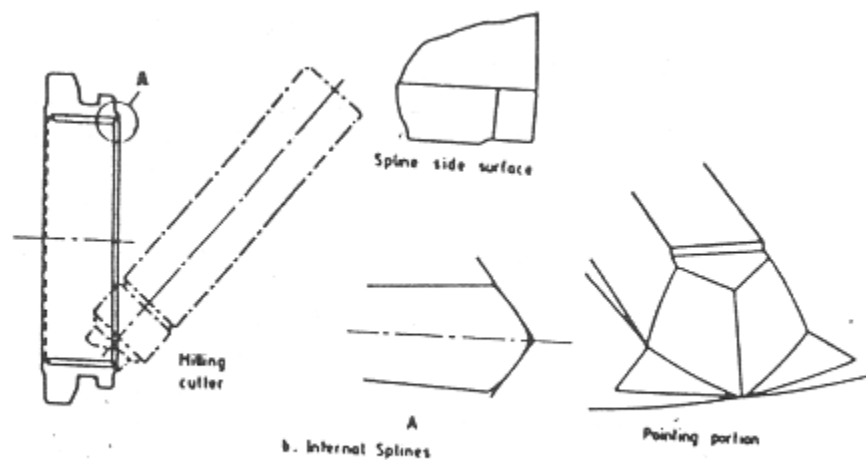

Fig. 4.39 Different Forms of Tooth Pointing

On a CNC version (Fig. 4.40), workgear rotation (X-axis) and the two cutter head axes (Y and Z) are electronically controlled. Teeth of both internal and external gears and/or splines can be chamfered by changing the position of the cutter heads and tools. Servomotor via a backlash - free worm wheel drive rotates the workgear axis. An incremental encoder on the work axis eliminates the index plate. So it is possible to have chamfering with unequally spaced divisions or with no chamfer on certain number of teeth. CNC is used to set the infinitely variable rotational speed of cutting tool. With speed available upto 5,000 rpm or so, carbide or coated carbide inserts can be used. The machine can also be used with a continuous motion between the workgear and the tool by means of a synchronising element for the rotary motion added to CNC system. The stroke of the cutter spindle is controlled through a ball screw driven by servomotor. Stroke rate may be upto 200 or more per minute. Programming is very simple. Data input may be the number of teeth of the workgear and feed rate. Setup changeover time is drastically reduced.

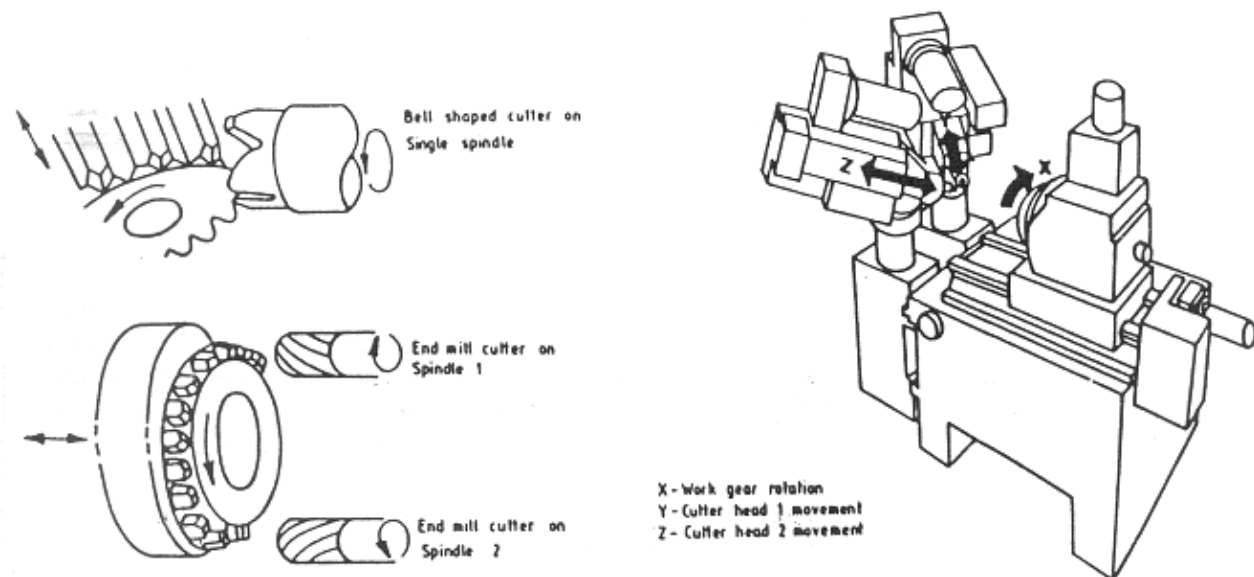

Fig. 4.40 A 2-spindle CNC Gear Pointing Machine

Various types of errors in pointing may be introduced if setup is not correct, Fig. 4.41. Error in chamfer angle is eliminated by adjusting the tilt angle of the two heads with respect to work axis. Ridge angle error is corrected by changing the cutting angle of the tool holder. Symmetry error is corrected by positioning the work holding mandrel. Profile error requires the correction of setting depth of cutterhead.

## Rounding

Rounding provides a radius on the ends of some gears, Fig. 4.42 to permit smooth shifting. The rounding is executed by a cam controlled sine shaped motion of a pencil type milling cutter over the tooth, while the gear is rotated on its axis. Many types of universal as well as dedicated machines are available for edge preparations. On universal machine, it is possible to carry out chamfering, pointing and also rounding. Machines with multi-heads and multi-slides are built for high speed operations. For shaft gears suitable support is provided on both ends. Generally, rounding takes more time because of constructional limitation of the fragile pencil point cutter. Designers now prefer to substitute rounding with wide angled

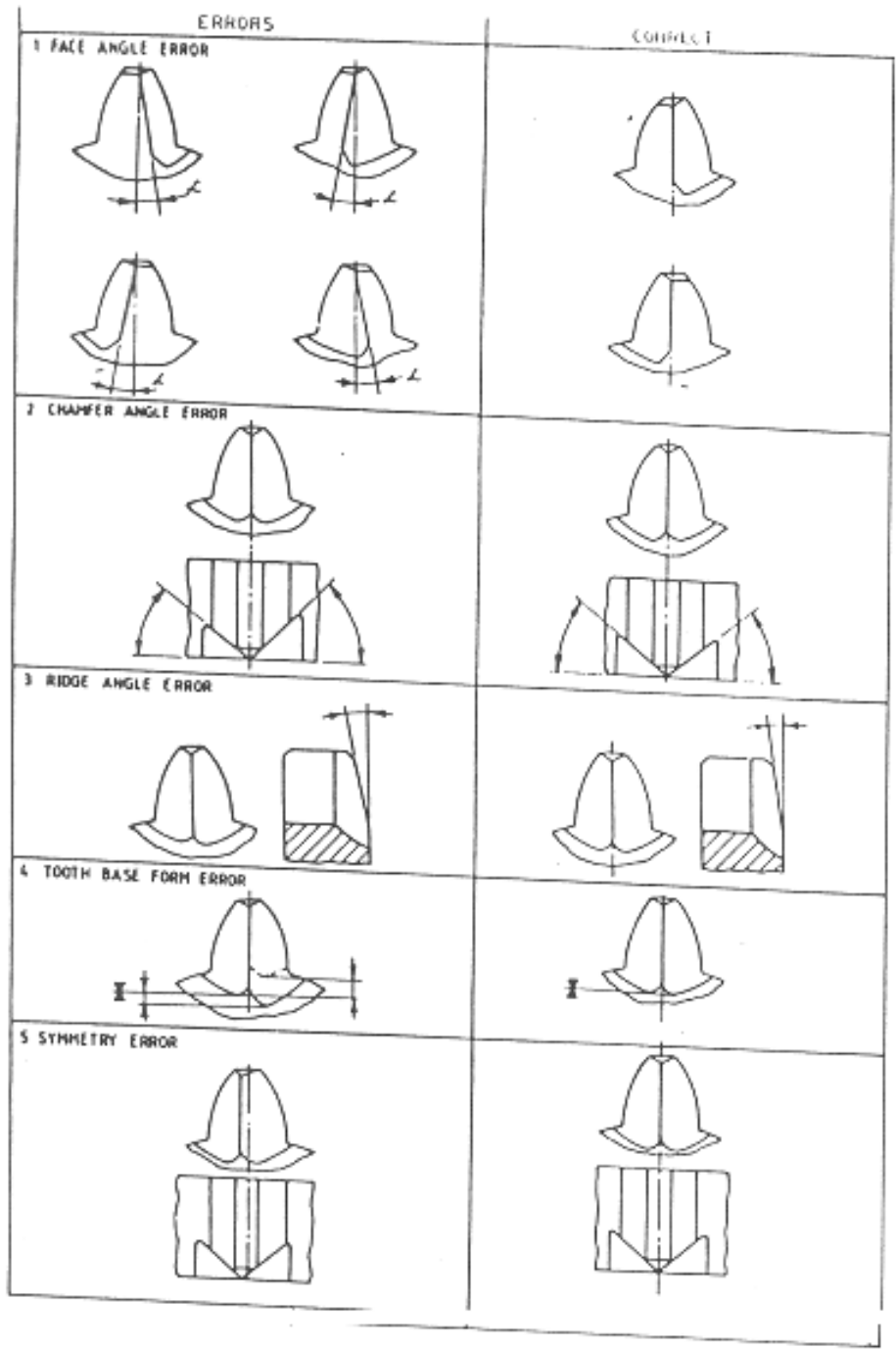

Fig. 4.41 Various Types Of Pointing Errors



4.42 Tooth Rounding

pointing, as the operation is very fast on the modern continuous indexing machine.

### Taper on Internal Spline Teeth

A short distance on one or both sides of spline teeth in sliding sleeves is provided with a taper to prevent slip-off of the dog teeth of meshing gears, Fig. 4.43. There are two ways of providing this taper.

**Method 1:** An expanding type tool with the desired taper built-in on its teeth is used. A hydraulic press of 30-60 ton capacity is applied to expand the tool and create the taper by plastic deformation of teeth in the zone where taper is desired. A positive control of the final stop of the ram gives the required depth of taper.

**Method 2:** A roller die with the required taper on its teeth is meshed with the internal splines. A relative pressure is created between the roller die and the workpiece to create the taper by plastic deformation. The component is rotated on its outside diameter. The tolerance of outside diameter is to be closely controlled (h9). In this process, taper on top and bottom sides of the component can be simultaneously finished. Life of the roller is very high and the accuracy achieved is much better. The amount of heat treatment distortion of the component is less if taper is provided by rolling process. A finish broaching operation is carried out after taper formation to remove the burrs created due to material flow in the process.

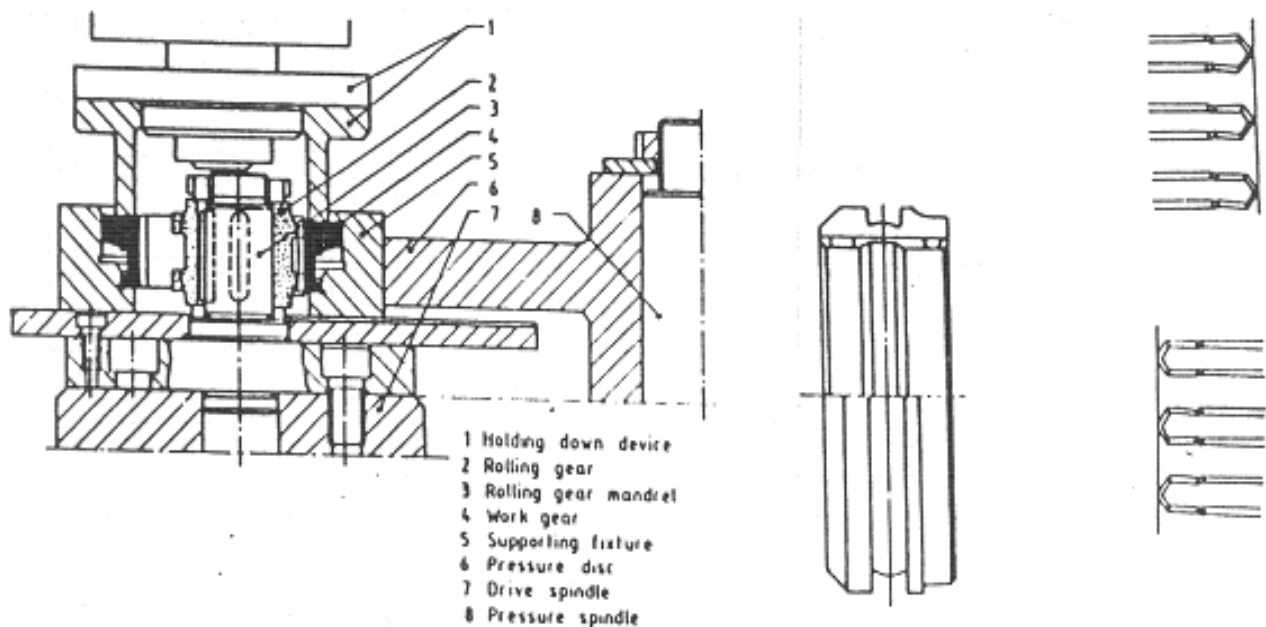

Fig. 4.43 Taper on Internal Spline Teeth, and Taper Forming Machine

### WHY SOFT GEAR FINISHING ?

Soft finishing process is planned to achieve the desired quality grade, surface finish and tooth modifications of gear teeth to meet the requirements of specific application. The quality grade

required for gears of upper speeds in automotive transmission is 7 DIN. Hobbing normally produces upto grade DIN 10 and shaping may attain upto grade DIN 9-10. With heat treatment after soft finishing, the quality grade deteriorates. So a gear finishing operation that can achieve a quality grade better than the specified DIN 7 (say, DIN 6), will be required. Again, surface roughness produced by hobbing/shaping processes - feed mark heights and scallops will cause noise and also defective rolling. So gear finishing operation becomes necessary to ensure better and consistent surface finish on the profiles.

Tooth modifications are essential for many reasons. True involute trace for teeth may not be ideal for gears running at high speeds. Undesirable noise is caused by impact load during tooth meshing even for normal no-load condition. Tooth profile is to be modified to reduce the impact loading. Again, in case of heavy loading, the teeth tend to bend. The bent tooth enters mesh before its mating tooth is in the proper location to receive it, and produces interference and noise. The entering tooth is to be modified to the same amount that the loaded tooth has deflected out of position. Amount of the modification of the involute profile required to take care of the impact condition and tooth deflection due to load is to be judiciously decided. If too little modification is bad for reducing noise, too much modification is infinitely worse. Similarly, the designed lead/helix angle of the gear may cause a situation that produces noise. Misalignment of mounting bores and deflection of the shaft under load further aggravates the situation. With crowning of gear teeth, the misalignment conditions between a pair of mating teeth may be corrected. Here again, excessive crowning may create more trouble; as it reduces the effective face width. Crowning to an amount of 0.008 mm per 25 mm face width is considered as sufficient. The crowning restricts tooth load to a little more than 85% of face width and also protects the vulnerable tooth ends. There may be situation when crowning of lead solves the noise condition under load, but when running without load the gear pair becomes noisy. A combination of taper and lead crowning on the gear teeth may overcome this problem. Again, the gear teeth may require certain modification at soft stage to compensate for distortion during heat treatment. Amount of modification required is established by continuous monitoring of heat treatment effect on lead and profile of gears.

Gear shaving, gear roll finishing, and gear grinding are the processes, applied by various manufacturers for soft gear finishing. Gear shaving is the most extensively used process. Shaving is used for the gears of upto 40 Rc. Shaving because of its process related characteristics have non-periodic recurring impulses as against the periodic ones, the characteristics of generating type grinding (with worm-shaped grinding wheel) and profile grinding. Non-periodic recurring impulses have more favourable noise behaviour. It has been established that shaved gears perform frequently with lesser noise problems than the ground gears. Shaving is also superior in respect of macro-geometric and micro-geometric characteristics of the resulting gear profiles. It does not produce heat checks that are generally produced in grinding.

## **GEAR SHAVING**

Gear shaving is basically a low pressure, free-cutting process. A helical gear-like cutter with closely spaced grooves extending from the tip to the root of each tooth, rotates with gear in close mesh in both directions during the shaving cycle. The centre distance between the gear and the cutter is reduced in small controlled steps to remove metal from the gear tooth surfaces till the final required size is achieved. The helix of the cutter is different from that of the gear to be shaved.

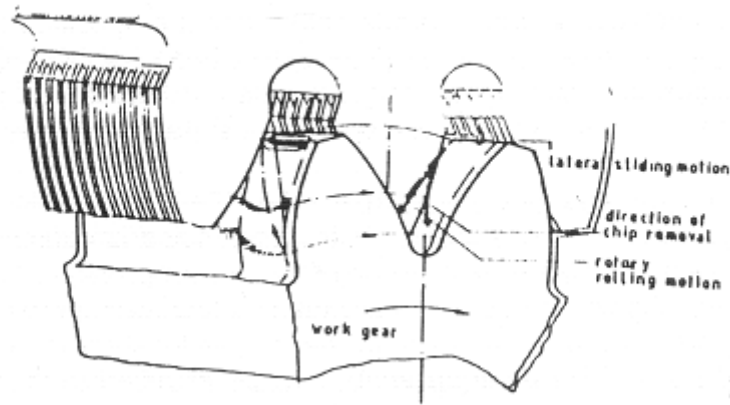

**Fig. 4.44 Meshing of a Gear with a Shaving Cutter**

For effective shaving, a pre-determined crossed-axes angle between the axes of the cutter and gear is important. The relative motion between the contacting tooth surfaces of the gear and the cutter, is composed of a rolling motion in the direction of the involute profile and a sliding motion along the length of the tooth, Fig. 4.44.

Again, the rolling motion along the involute is composed of a real rolling element and a sliding element. The rolling element is more prevalent near the pitch circle. However, as the contact of the tooth surfaces approaches the tops and roots of the teeth, the sliding element increases and the rolling element decreases accordingly. As the cutter rotates, the lands between the grooves act as cutting edges and remove fine chips from the gear profiles. The cutting action is provided by the relative sliding motion in the direction of tooth trace of the shaving cutter, Fig. 4.45.

Crossed axes ensure uniform diagonal sliding action from the tip to the root of the teeth as well as provide necessary shearing action for finish cutting. Higher crossed-axes angle increases cutting action but at the cost of guiding action as the area of contact is reduced. It may result in tooth lead error. With reduced crossed-axes angle, guiding action is improved as the area of contact is increased but at the cost of cutting action. Finished surface appears burnished. Optimum crossed axes angles are kept between 10 - 15 degrees for most transmission gears. For shoulder gear, the angle is kept around 3 degree. For internal gears, the angle varies between 3 to 10 degree.

Shaving is a combination of cutting as well as burnishing. The cutting edge follows a path  $d$ , while it moves from the time the shaving cutter contacts the tip of the gear and leaves after completing its cutting, Fig. 4.46. On the other side of the tooth, the tip of the cutter tooth comes first in contact with dedendum of the gear, and completes the shaving at the tip of the tooth of the gear. The contact pressure between the cutter and the gear is obtained by radial infeed. Theoretically, the contact between the cutter and the gear in conventional shaving is concentrated at a single point if there is no mutual contact pressure. However, actually the contact takes the form of a long ellipse, because the tooth flanks are pressed one against other, Fig. 4.47. Size of the ellipse depends on the radius of curvature of the mutually

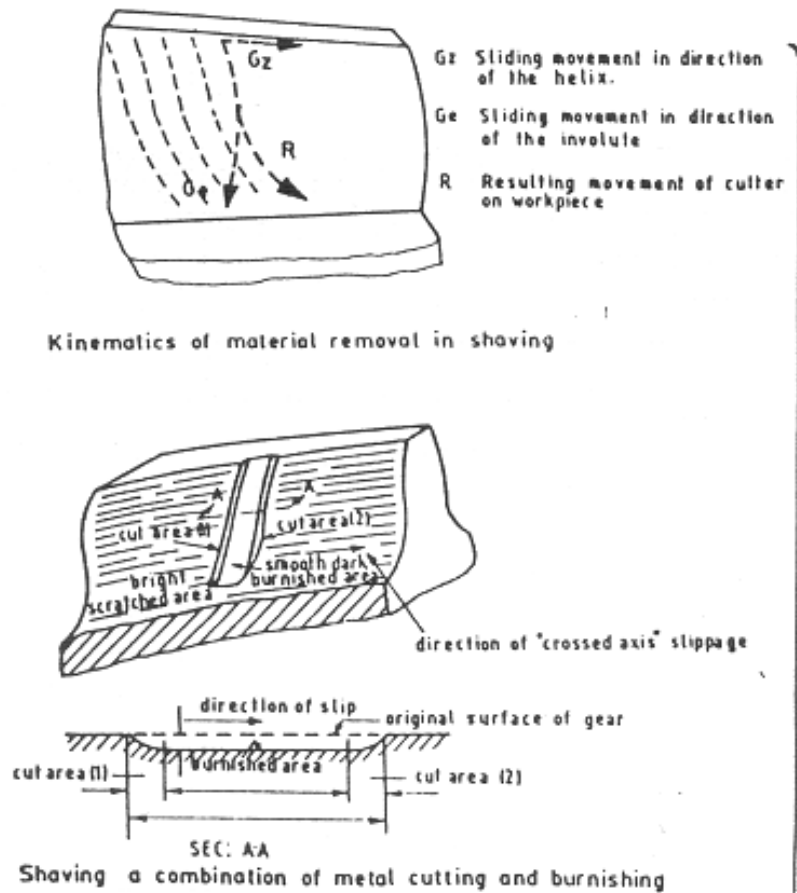

Fig. 4.45 Cutting Process in Gear Shaving

engaging tooth surfaces, the amount of crossed-axes angle, the contact pressure and the elasticity of the work material. However, the ellipse does not cover the whole width. A relative traversing motion is required to cover the total face width of the gear. So the gear is traversed back and forth across cutter width. The gear is free on its axis and is driven only by the cutter. The cutter design (helix angle, number of teeth, shape of serrations, contact ratio and operating pressure angle) basically decides the cutting performance as well as accuracy of the shaving process to a great extent.

Shaving removes the cutter marks, waviness and surface irregularities of the pre-shave gear generating process. Surface finish of shaved gears may be even as good as that after grinding. Tooth size is maintained as specified within a closer tolerance. Tooth quality is improved depending on the nature of the gear tooth error. Profile and lead accuracy are



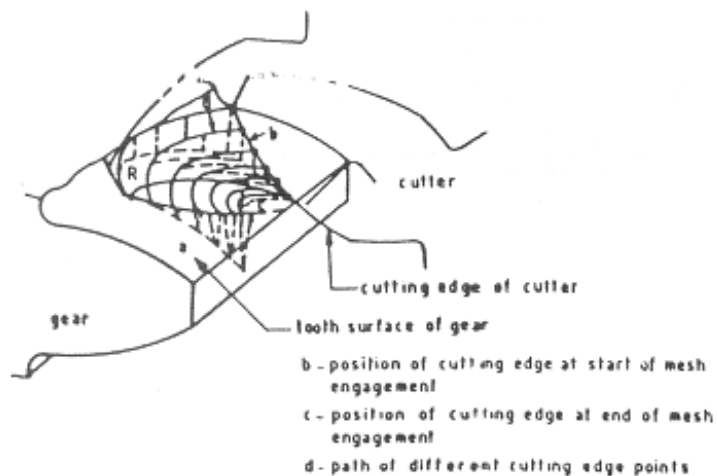

Fig. 4.46 Relative Sliding Motion of Cutting Edge

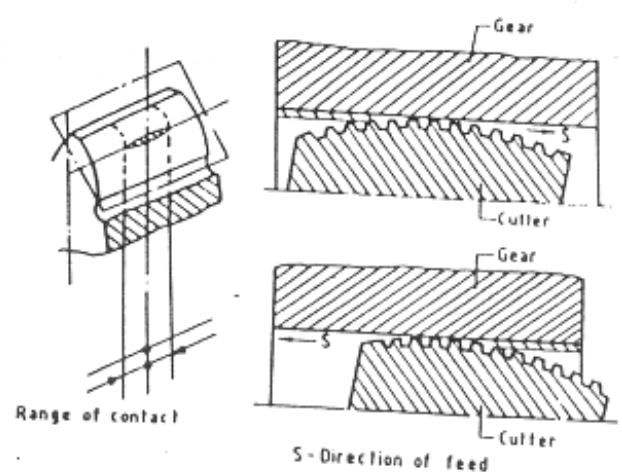

Fig. 4.47 Contact Pattern in Shaving

remarkably improved. Base pitch error and the difference between the adjacent pitches are reduced greatly. However, the gear may still have a greater cumulative pitch error, if the concentricity during gear cutting has not been controlled carefully. Modifications for longitudinal crowning and tapering of gear teeth are easily and accurately carried out by using the built-in crowning mechanism. The profile corrections, such as tip relief or root relief, are obtained by modifying the tooth profile of the shaving cutter according to the requirement. For certain methods of shaving, all modifications are attained through the modifications of shaving cutter only. These modifications compensate for misalignment in final transmission assembly and for heat treatment distortions as well as produce the desired tooth bearing for uniform load distribution. Gear noise is reduced and load carrying capacity is increased. Under favourable conditions, shaved gears take four times as much load as hobbed gears in high speed transmissions.

### Shaving Methods

The pivot point, i.e. the point of intersection of the axes of gear and shaving cutter moves across the face of gear in different methods. Direction of reciprocating stroke is different for different shaving methods, that are designated accordingly.

1. **Conventional Shaving:** The work table traverses in the direction of the gear axis, Fig. 4.48. Traversing stroke is adjusted to cover the total face width of the gear. A number of table strokes, each with its increment of upfeed, are required to complete shaving in proper way and thus takes the maximum time. Cutter life is inferior as the pivot point of the cutter is always located at the same place on the shaving cutter. So the cutter wear does not extend to whole width. Feed length is about the same as the face width of the gear. The method is suitable for gears with wide face and naturally not suitable for shoulder gears. For crowning the teeth of gear, the machine table is rocked by built-in crowning mechanism.

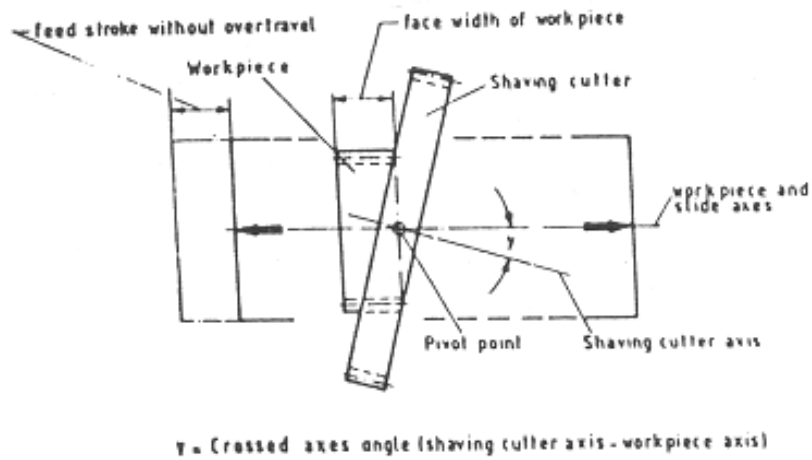

Fig. 4.48 Conventional Shaving

2. **Diagonal Shaving:** The worktable traverses at an angle to the gear axis, Fig. 4.49. Along with traversing motion, the pivot point moves across the entire face width of the shaving cutter. So cutter wear is uniform and the cutter life increases. Width of the shaving cutter depends on the face width of the gear and the diagonal angle. In shaving a wider face gear with a narrow faced shaving cutter, only a small angle diagonal traversing is possible.

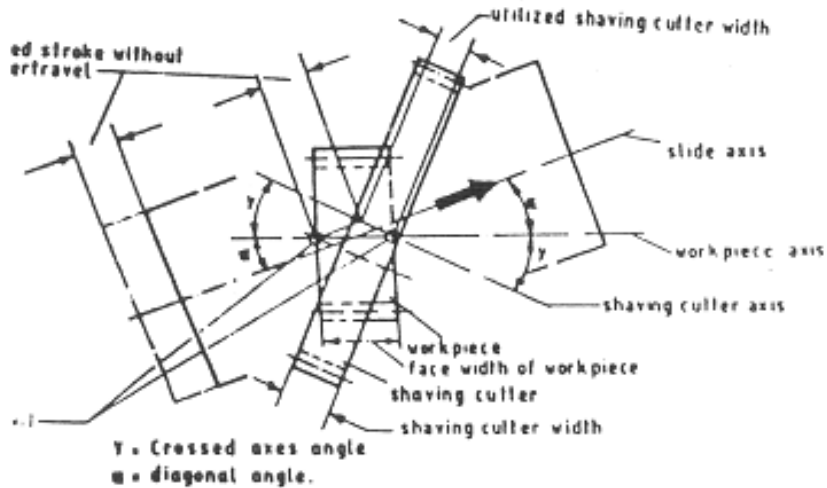
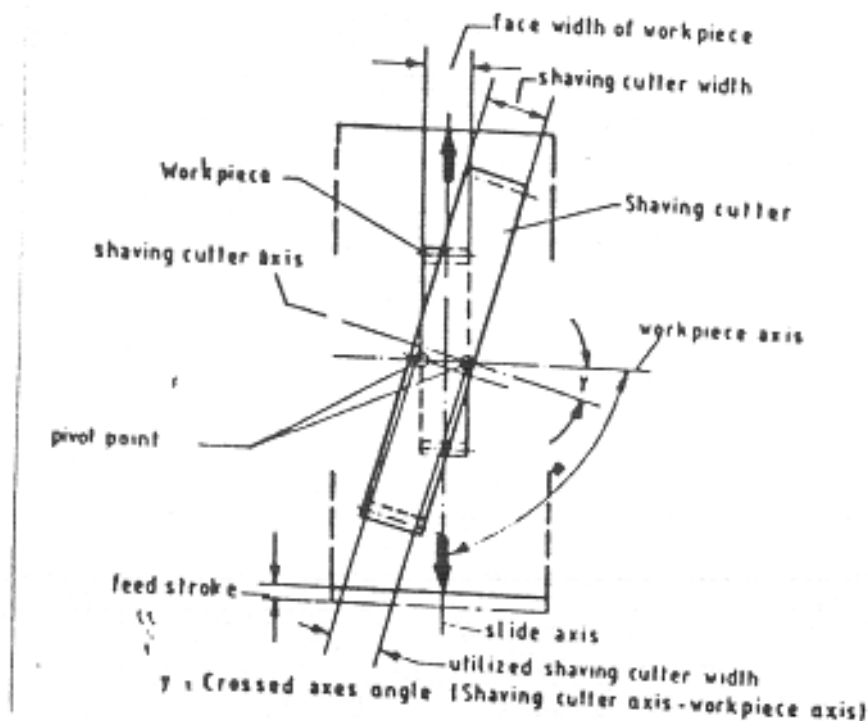

Fig. 4.49 Diagonal Shaving

With wider shaving cutter, a larger traverse angle can be used. So in this method the cutter can shave a gear of slightly wider face width depending on traverse angle. Feed length is shorter than that in conventional method. Number of reciprocating table movements is

smaller than that for conventional. Short feed length and lower number of reciprocating movements result in substantial reduction in shaving time. Crowning of the gear teeth is accomplished by rocking the machine table provided the sum of the diagonal traverse angle and crossed-axes angle does not exceed 55 degree.

When the diagonal traverse angle is between 40 - 90 degrees, the shaving method is sometimes called Traver- pass shaving. Traversing is so short that the shaving action does not cover the entire tooth surface. Width of the shaving cutter is more than the gear face width. As the traverse angle approaches to 90 degree, machine controlled crowning is no longer possible. Crowning is obtained by modification of cutter only. A special cutter with differentially staggered gashes becomes essential when the traverse angle is above 60 degree to have effective shaving of the entire tooth surface. The process can be used for shoulder gears.



#### 4.50 Underpass Shaving

3. **Underpass Shaving:** In underpass shaving, the direction of traversing is at right angles to the gear axis, Fig. 4.50. The gear is rolled into the shaving cutter teeth in a single forward and return stroke from an initial centre distance to the desired final centre distance. So the underpass shaving time is minimum compared to all other shaving methods employing traversing. A special shaving cutter with mutually staggered gashes is required to clean the entire tooth surface. Direction of feed is perpendicular to the gear axis. Feed length is smaller than that for conventional and diagonal methods. Tool life is better because of uniform wear, as the pivot point of the cutter moves along the entire face width. Cutter width is to be more than the width of gear. The pitch surface of the cutter is given a hyperboloid form (concave

curvature) to ensure proper contact across the full face width of the teeth. Concave pitch surface on the cutter is obtained by negative longitudinal crowning of the cutter teeth. This method is most suitable for shoulder gears with critical clearance between the gear and the shoulder. Limitation of this method is the width of the cutter that must remain economical.

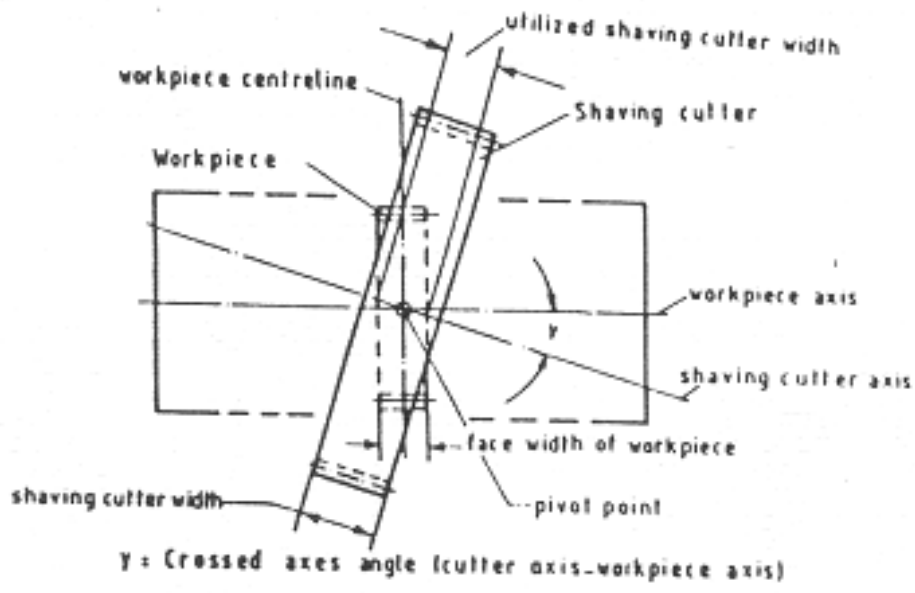

Fig. 4.51 Plunge Shaving

4. **Plunge Shaving:** Plunge shaving is the later developed method, where only a radial infeed motion is sufficient without any relative traversing, Fig. 4.51. The shaving cutter is specially ground for negative longitudinal crowning of the cutter teeth to ensure uniform stock removal in crossed-axes relationship. The cutter width is greater than the width of the gear. The cutting grooves in consecutive cutter teeth are differentially staggered so as to describe a helix and to cover the entire tooth surface during shaving. The ratio of the number of teeth in the gear and the cutter, the hand of the helically-arranged serrations, and the direction of crossed axes angle to one another, are selected judiciously. The proper selection ensures that the direction of the axial sliding motion will coincide with the progress of the cutting edges consecutively coming into cutting contact with the gear flank. The individual chip removals will follow one another without any gaps in between. The direction of such chip removals will be from the machined portion of the flank of each gear tooth towards the unmachined portion. Chip formation in this way is essential to improve the surface finish. Another factor for a high quality surface finish is the size of the tooth to tooth steps or relative offset, of the staggered cutting edges.

For selecting the best method for the specific application, the salient features of different shaving methods must be understood clearly. Each has certain advantages with some limitations. Conventional is slower but flexible, and is recommended for small batches - even one off and also for wider gears where other methods become uneconomical because of required excessive width of cutter. Gear of practically any width can be shaved by conventional method. Diagonal is faster and is recommended for medium and large batches.

Traverpass and underpass are fast and suitable for shoulder gears. Plunge is the fastest of all shaving methods and is being increasingly used for certain gears in mass production.

**Plunge Shaving - the basic advantages:**

In plunge shaving, the contact area of the cutter and the gear is extended in longitudinal direction into a hollow state, and the whole of the tooth surface can be shaved without traversing, Fig. 4.52. The tooth profile on the each section in longitudinal direction of gear after shaving can be made equal. The profile can also be changed by shifting the tooth profile on the each section in longitudinal direction of shaving cutter with grinding longitudinally concave teeth of shaving cutter by means of specific grinding method.

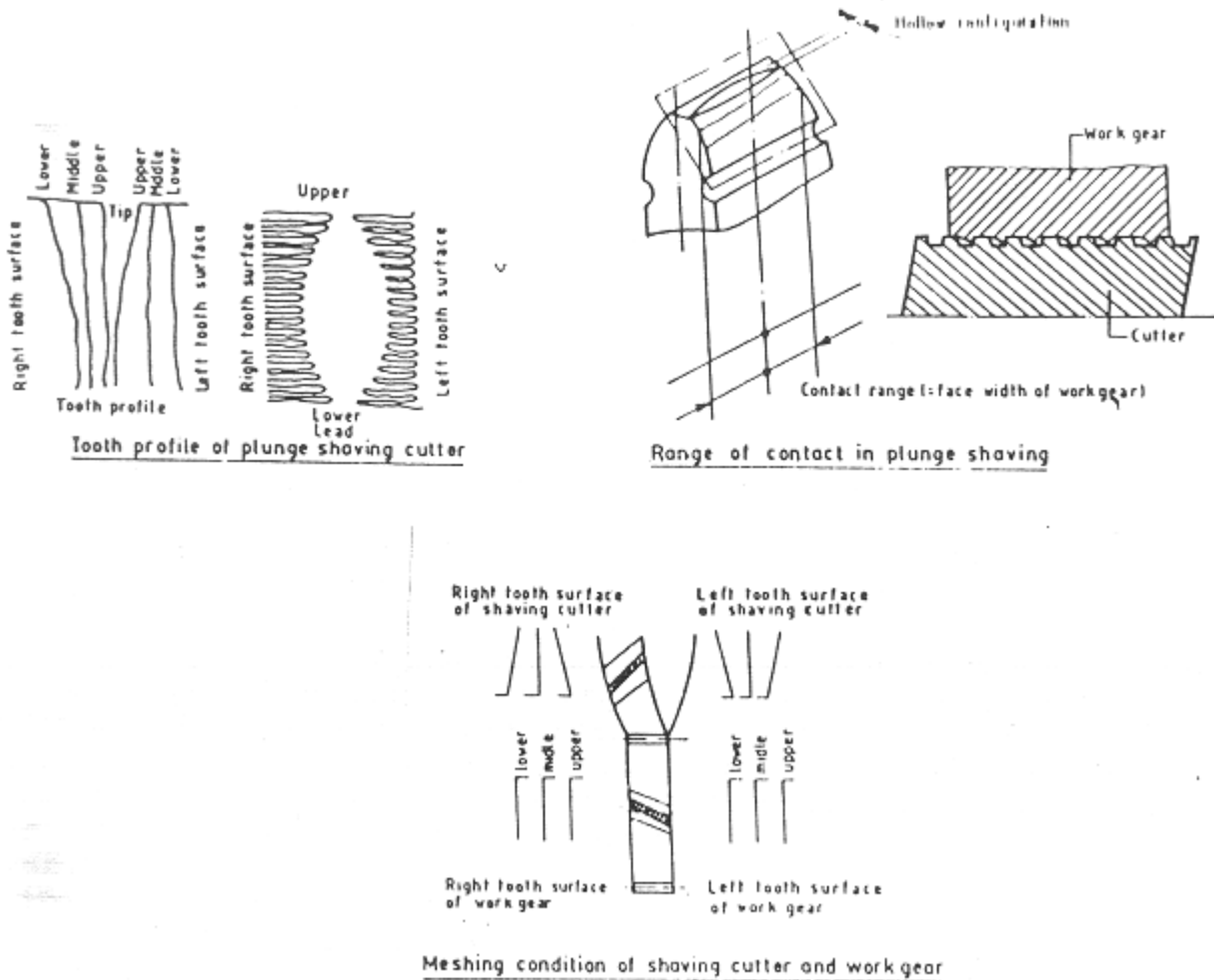

**Fig.4.52 Meshing Condition of Shaving Cutter and Gear**

Advantages of plunge shaving over other shaving methods are:

- Relative traverse feed of the gear and the cutter are not necessary and cutter feeds only in radial direction of gear. The cutter reverses its direction of rotation only once after dwell. In conventional shaving, the direction of cutter rotation is

reversed every time the traverse feed is given. It results in considerable saving in shaving time. It will be clear from the shaving cycle diagrams of both methods, Fig. 4.53. Moreover, the peripheral velocity for plunge shaving is 20% more than that for other methods. The method does not require continuous reversals of rotation of cutter at both ends of the traverse feed motion. Productivity is about two times better by plunge shaving even if it is compared with diagonal shaving

- In plunge shaving, the tooth surface roughness is remarkably improved because the feed mark of cutting edge of the cutter comes in between the previous feed position, Fig. 4.54. In conventional shaving, the tooth surface roughness will not improve even if the number of finish shaving is increased, and the feed mark of the cutting edge of the cutter is consistent. Tooth surface roughness of the plunge shaving is better by about a half of that produced by conventional shaving.

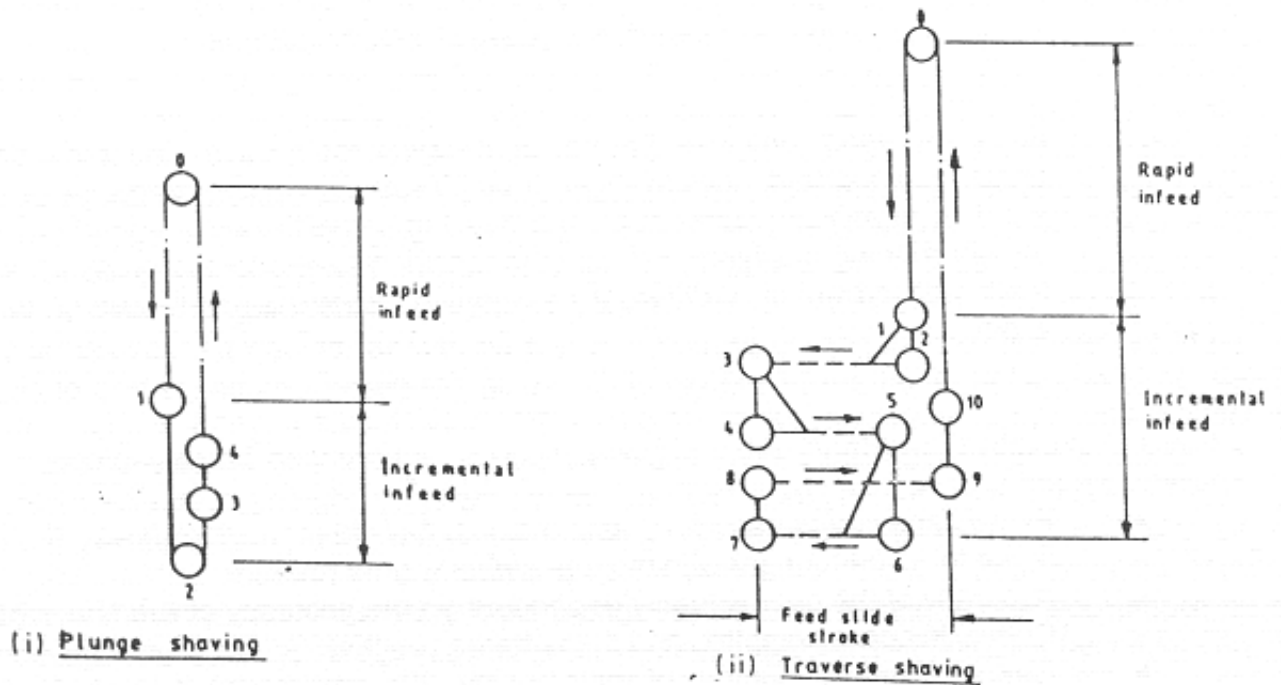

Fig. 4.53 Shaving Cycles for Traverse Shaving and Plunge Shaving

- Back movement mechanism of plunge shaving that affects a small (max. 0.05 mm) retraction of the infeed from the final position, and results in better accuracy. Tooth space runout and cumulative pitch error are less. However, the amount of back movement is to be carefully decided, as it affects surface finish.
- The cutting amount for each serrated cutting edge is uniform, because the cutting edge acts uniformly on tooth surface at any position in direction of tooth trace. Chips produced are uniform, long and narrow. In all other methods, the cutting amount of each serrated cutting edge will be unequal. Chips are totally non-uniform. Tool life is significantly better in plunge shaving.

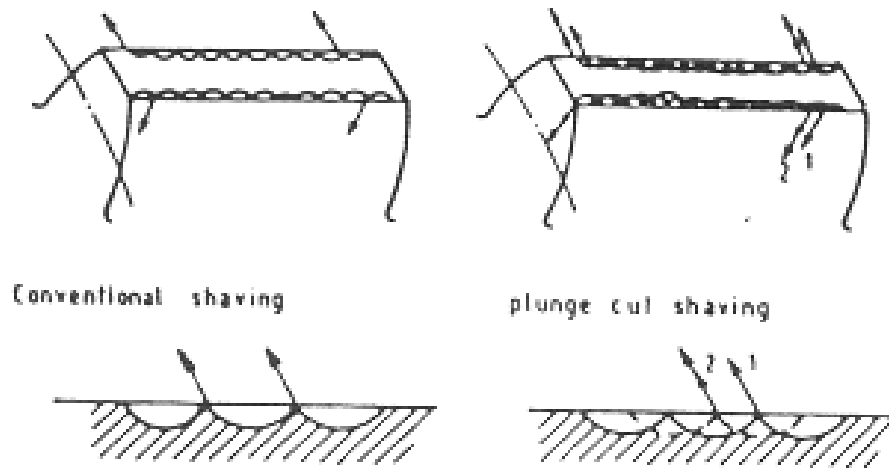

Fig. 4.54 Feed Marks caused by Cutting Edges

- Plunge shaving can make the bias on the gear tooth trace. The same pressure angle can be kept toward gear tooth trace. This is possible with special grinding of shaving cutter in plunge shaving using the eccentric pitch block of the sharpening machine. For all other shaving methods, the pressure angle of teeth with crowning is different between the centre and the end of the tooth width.

However, **certain limitations** of the process must be appreciated before selecting plunge shaving method.

- Plunge shaving is used only upto maximum of 40 mm. wide gears. Similarly, it is not for used for gear with module higher than 4 (max. ).
- Accuracy of the gear is totally dependent on the accuracy of the shaving cutter. Cutter design is complex, and the cutter is costlier.
- Gears of smaller number of teeth (below 20) can be shaved only with under cut, which may not be required for diagonal/underpass.
- Regrinding of plunge shaving cutter is critical and will be difficult unless the cutter grinding machine is equipped with highly precise controls.

Basically, the gears are to be redesigned to avail the advantages of plunge shaving. Japanese auto builders are almost universally using plunge shaving for transmission gears of passenger cars. In opinion of many experts, the noise of gears finished by plunge shaving is lower than that finished by diagonal or conventional shaving.

### Preshave gear quality

For effective gear finishing by shaving, it is essential to produce fairly accurate gear teeth during hobbing and shaping. Basically, shaving only improves upon the accuracy as already obtained during hobbing/shaping. As a thumb rule, shaving reduces the errors of

hobbed/shaped gears by 60% to 80%, if stock removal is strictly as recommended for the module of the gear. Generally, the accuracy of preshaving operations should not be more than 2-0 quality grades (preferably less) lower than that desired after shaving.

Preshaving cutters must be of good accuracy and must not generate very deep scallops or feed marks that can not be covered by the shaving allowance provided. Excessive stock will only reduce the cutter life. Shaving cutters are designed to maintain the symmetry of forces keeping a particular amount of stock on the finished gear size. With excessive shaving stock, the deviation from the optimum relationship of shaving cutter and the meshing gear is so great that the profile deviations produced in the initial phase of shaving can not be corrected any more by the end of the shaving cycle.

## **Gear Shaving Machines**

Universal machines can use any of the shaving methods-conventional, diagonal, underpass and plunge, for small to medium batch sizes. The cutter head is motor driven and can be swivelled to obtain the required crossed axes angle. Cutter head is mounted above the gear, so that there is no chance of dropping of a gear on cutter during loading/unloading. Chips fall down away from the cutter and do not clog the cutter serrations. The gear is loaded between live centres on the reciprocating work table. The reciprocating table is, again, mounted on a round table with sector gear and pinion to precisely set traversing angle for reciprocating motion with ease. The work is upfed at decided incremental rate to obtain the required over pin size of the gear. The worktable is equipped with a rocking mechanism coupled to the traversing motion for tooth crowning of work gear. The table is supported at one end by means of guide rolls engaging a guide rail that controls the rocking motion during traversing stroke. The guide rail can be adjusted both to an angular position related to the table plane and in height. When the guide rail is parallel to the table plane and at normal level, the gears will have parallel sides. When the guide rail remains at normal level but set at an angle, the teeth of the gear will be crowned. When the guide rail is in horizontal position but adjusted in height, the teeth will be tapered. Again by setting the guide rail at an angle and adjusting its height, tapered teeth with longitudinal crowning can be produced. On some machine, the cutterhead is downfed and the worktable height is kept constant. High production shaving machines with only plunge cycle are getting more acceptance in automotive industry because of their built-in advantages. Machine kinematics becomes very simple.

Modern machines are equipped with hydraulic unlocking and locking of cutter head and table slide. Display of angular positions is common. Cutter speeds, traverse feeds and radial infeeds are infinitely variable and programmable. Hydraulic tailstocks may be positioned mechanically. Cutter change time has been reduced drastically with some quick cutter change systems. On CNC shaving machines, Fig. 4.55, the setup time can further be reduced, and the repeatability is improved. Basically on the CNC version, the slides of the X-axis (table feed) and Z-axis (radial in-feed) are driven through ball screws by servomotors with incremental encoder. The slides are backlash free, as the ball elements are preloaded. The setting of the crown/taper axis is done by a servomotor via a backlash free worm with the encoder on ball screw. The settings of the crossed-axes angle and the diagonal angle are through high precision ring gears driven by separate servomotors. An incremental encoder is integrated in the distance measuring system. After the completion of movement for setting change, the axis gets automatically locked.



**X - axis : Table Stroke Control**  
**Y - axis : Cutter angle Control**  
**Z - axis : Infeed Control**  
**C - axis : Table Angle Control**  
**B - axis : Crowning Control**

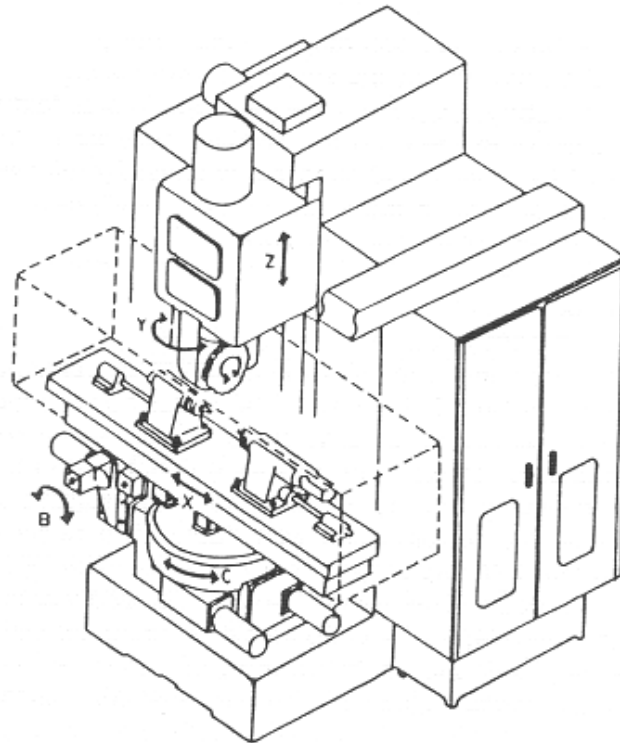

**Fig.4.55 A CNC Shaving Machine**

The initial development for establishing tooth geometry for a new gear involves cutter regrinding for a number of times. The development time is much less on CNC machine. With input of the cutter and gear data, the setting adjustments are calculated and made more accurately. The number of test shavings, regrindings of cutter and measurements is drastically reduced.

### **GEAR ROLL FINISHING**

In the process, a soft gear is meshed with the rolling die and rotated under pressure for finishing by plastic deformation occurring simultaneously along contact line. As a gear rolling die tooth engages the approach side of a gear tooth (Fig. 4.56), sliding action occurs along the line of action in the arc of approach in a direction from the top of the gear tooth toward the pitch point where instantaneous rolling action is achieved. When the contact leaves the pitch point, sliding occurs now in the opposite direction towards the pitch point in the arc of recession.

The contact between the teeth of die and gear on the trail side produces exactly the opposite direction of sliding to that on approach side, Fig. 4.57. As a result, the material is compressed towards the pitch point on the approach side and is extended away from the

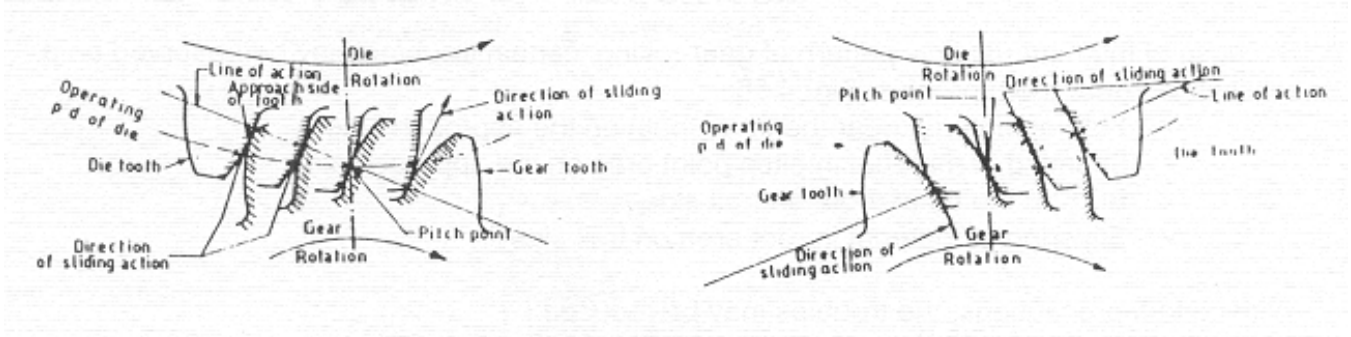

Fig. 4.56 Approach Side of Rolling Die Teeth      Fig. 4.57 Exit Side of Rolling Die Teeth

pitch point on the trail side. This action causes a greater quantity of material to be displaced on the trail side than on the approach side approximately in the ratio of 3:1. On the approach side, the tendency is to trap the material. While on the trail side, the tendency is to permit it to flow towards the top and root of the teeth. Obviously, the material stock allowance for finish rolling and hardness of the material is extremely critical and influences the accuracy and quality of gear roll finishing to a very large extent.

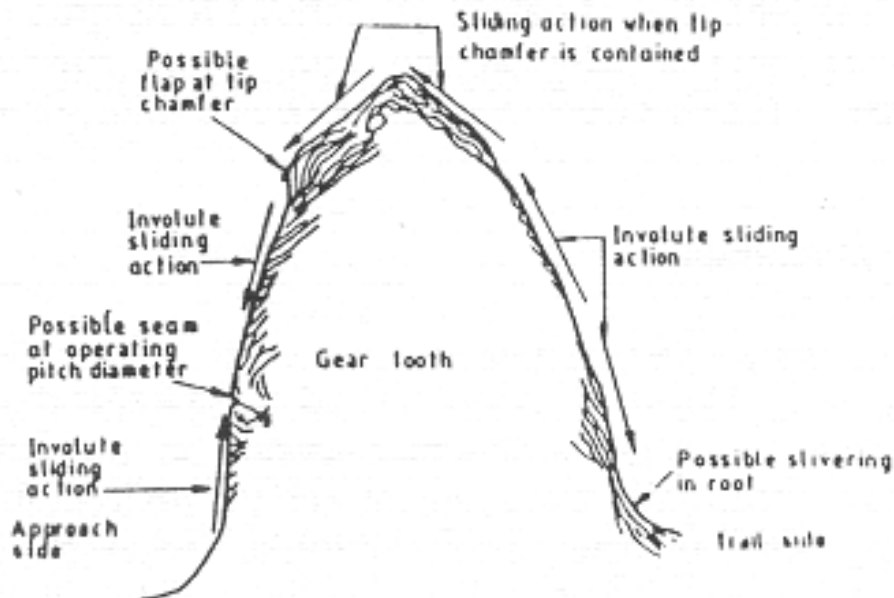

Fig. 4.58 Typical Troubles in Roll Finishing

In roll finishing the metal flows and smoothens the surface. There is no metal removal as in gear shaving. Some obvious advantages of this roll finishing process are as follows:

- ✓ Cycle time is extremely short in range of 5 to 8 sec.
- ✓ Surface finish is excellent.

- ✓ Tooth strength is improved.
- ✓ Dimensional control is better and uniform.
- ✓ Tool life is high if pre-rolling conditions are controlled.

### **Inherent Troubles in Roll Finishing**

Because of the material flow pattern of gear rolling, certain troubles may be observed on a roll finished gear tooth profiles, Fig. 4.58:

- ✓ Flap of material near the tip of tooth on the approach side
- ✓ Seaming of material in pitch point area on the approach side
- ✓ Burr on the tip of tooth on trail side
- ✓ Silvering of material in root area on trail side

With certain precautions, the troubles may be reduced:

- Stock allowance is to be kept to a minimum. With modern gear shaping and hobbing machines, the overpin dimension of gear teeth can be uniformly maintained within a closer tolerance. As a thumb rule, the stock for rolling is to be 50% of that for shaving. An intermediate gauging station between gear cutting and gear roll finishing will be advisable for 100% size control.
- Rollable gear steels with consistent uniformity of hardness, micro-structure, and stress characteristics will be essential for desired quality of roll finishing.
- A suitable undercut at root as obtained with preshave hob/shaper cutter will be desirable.
- Tip chamfering will be necessary in hobbled/shaped teeth. Chamfer depths and angles are to be held within close tolerances. Rolling die design may eliminate the need of varying dimensions of chamfers on each side of the tooth.
- During heat treatment, lead of helical gear shows a distortion with a larger helix angle at the tooth tip and smaller at the root. The involutes are also distorted correspondingly. These errors are compensated with allowances designed in roll finishing dies.

### **Gear Roll Finishing Machines**

For gear roll finishing, many types of machines are used. In one, two dies are mounted one above the other, Fig. 4.59. Upper die head is fixed. The lower die is fed upward to roll the gear to the desired size. Loading is automatically done on the work arbor with system built in the machine to ensure clash-free engagement with the teeth of the dies. Provision for the phasing of the two die heads is made on one of the die head drive shaft. This provision is incorporated to make the teeth of the two dies in proper timing with the teeth on the gear.

Another type of the gear roll finishing machine uses only one die, Fig. 4.60. The motor driven die meshes with the gear and provides the rotation. The work table with gear mounted on an arbor between head and tailstock is fed upward to an adjustable positive stop for correct sizing. The gear is rotated in one direction in first part of the cycle and then reversed for the rest of the cycle. Rotation of the die in both the directions provides the balancing of metal flow action on the approach and trail side of the gear teeth. The machine provides with facilities to change the helix and taper attitude of the spindle to make corresponding corrections to the geometry of the gear. Force required for roll-finishing of

- |                          |                           |
|--------------------------|---------------------------|
| 1. Drive Motor           | 9. Taper Adjustment       |
| 2. Multiple V Belt Drive | 10. Aerial Adjustment     |
| 3. Gear Box              | 11. Upper Die             |
| 4. Universal Joint       | 12. Workpiece             |
| 5. Roller Ways           | 13. Lower Die             |
| 6. Work Table            | 14. Moving Lower Die Head |
| 7. Swivel Adjustment     | 15. Hydraulic Cylinder    |
| 8. Upper Die Head        |                           |

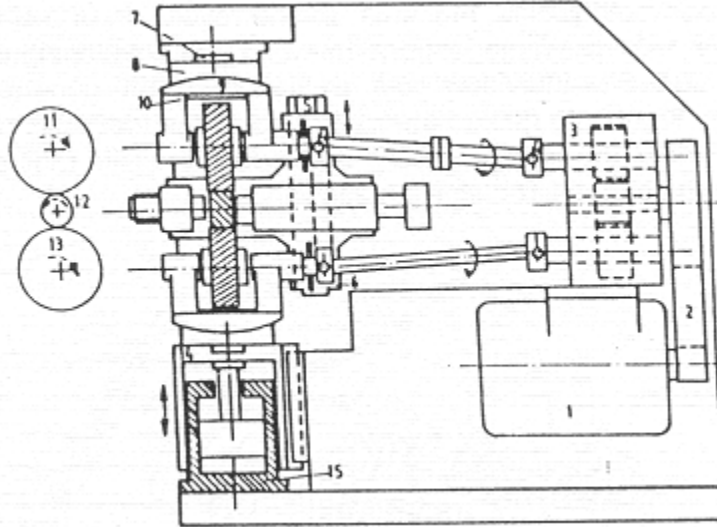

Fig. 4.59 A Twin Die Gear Roll Finishing Machine

gears depends upon its width, module, helix angle, tooth pressure angle and shape along

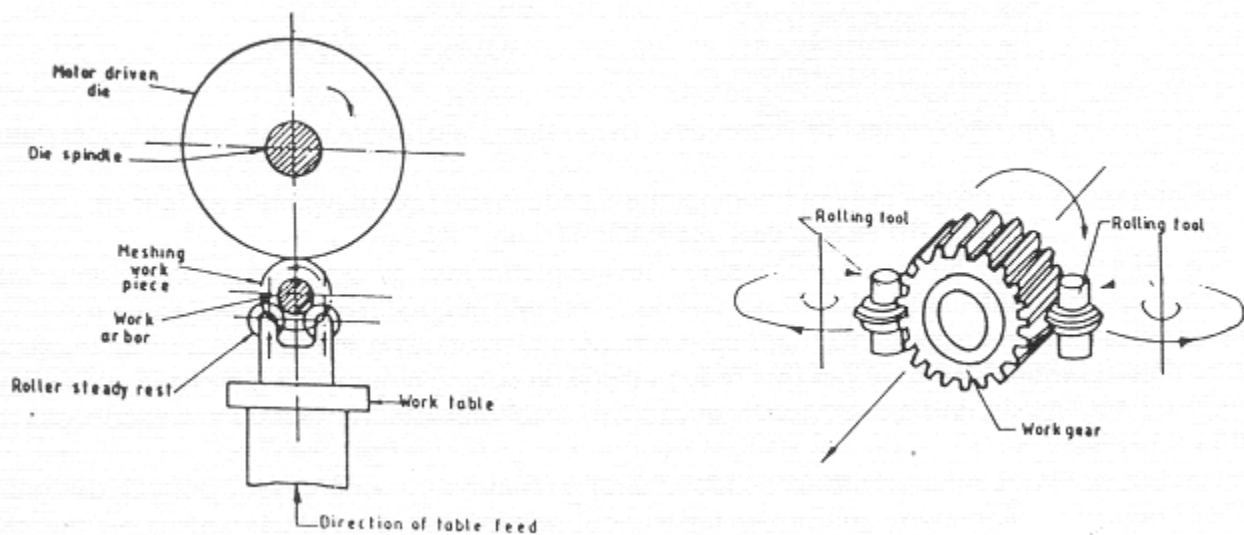

Fig. 4.60 A Single Die Gear Roll Finishing Machine

with its material and hardness. Twin die machine may be recommended for high production runs, and single die machine for low and medium batch production.

## CUTTING TOOLS IN GEAR MANUFACTURING

### Hob Cutter

A hob is a cylindrical worm gashed lengthwise to create a number of teeth with relieved sides and also the outside diameter. Cutting edges are arranged along a helix. Deviations from the theoretical generating helix of the hob affect the polygonal path of the enveloping cut along the gear tooth profile, Fig. 4.61. In one revolution of a single thread hob, each of the cutting edges removes material from the tooth gap enveloping the profile. The profile is generated by a series of individual cuts. Deviations in the generated helix are the profile error of the gear. The basic rack of the gear determines the basic rack of the tool, defined by the pressure angle, the addendum and dedendum, the fillet radius, required modifications of addendum profile and desired shaving allowances.

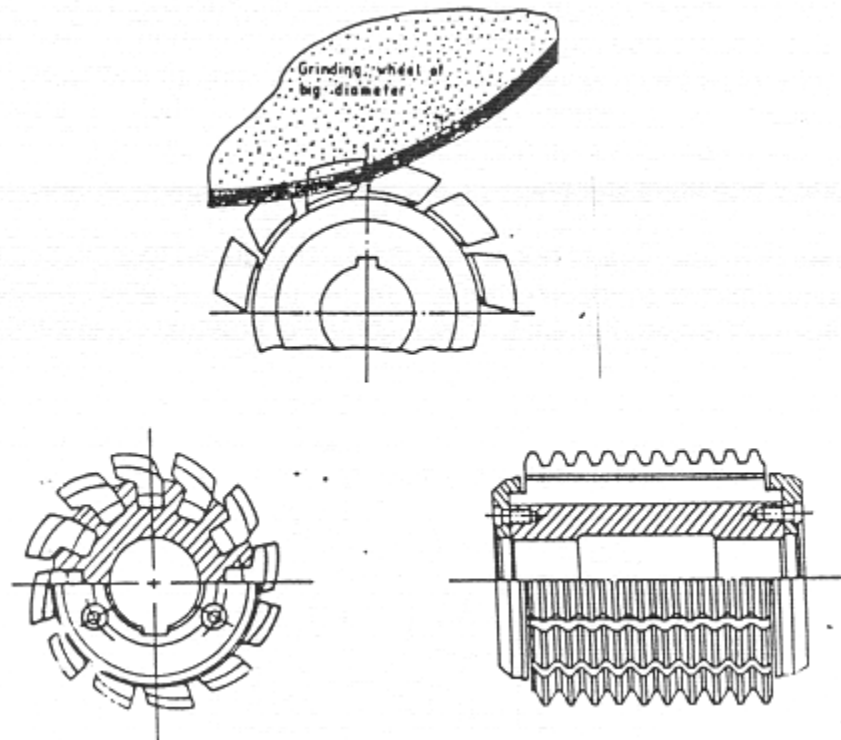
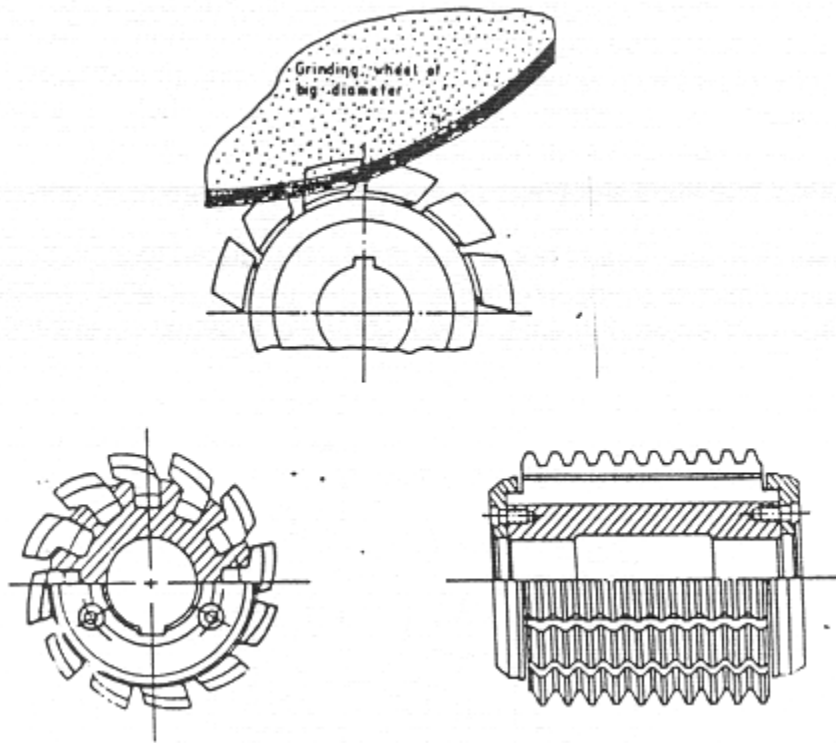

Fig. 4.61 Effect of Theoretical Generating Helix Angle of Hob on Polygonal Path

For improving the productivity of hobbing, the trends in the hob design are as follows:

- Effective hob length is increasing to keep the tool in cutting for longer time with automatic hob shifting and thus to reduce the tool change time in a production run.
- Smaller hob diameter for high speed hobbing is reducing the clearance requirements for approach and over-run that reduce the total cutting time. With side keyway (instead of keyway in the bore), the reduction in hob diameter is possible without loss of stiffness.
- Special hobs incorporate quick tool changing feature. In one case, specially designed hob pilot diameters guarantee the runout within less than 0.01 mm, keep the dirt particles outside and ensure firm drive by high axial clamping force.

- d. Use of *inserted blade hobs* (built-up hobs) has largely improved hobbing efficiency as well as accuracy because of inherent construction features, Fig. 4.62. Tool life is almost twice compared to solid hobs. Inserted blade hobs have overall advantages over the solid hobs with only few limitations.
- e. Judicious application of *multi-thread hobs* for pre-shave hobbing reduces the hobbing time to minimum, Fig. 4.63. The heavy roughing load is split up into two or more locations around the periphery of the hob, which results in more uniform cutting action than that of a single thread hob. Basically, a multi-thread hob has more than one thread of teeth winding around its outer surface. So one revolution of the multithread hob advances the work gear by  $n$  teeth (where  $n$  is the number of threads on the hob) thus reducing the hobbing time in the same proportions. However, the total number of the teeth of hob to finish each tooth of gear decreases as the number of thread of the hob increases. It results in generating flats on the tooth surface and thus in greater tooth form error that is proportional to the second power of the number of thread.



**Fig. 4.62 An Inserted Blade Hob and its Grinding**

The relation between the number of threads of hob and the number of teeth in gear affects the relation between the hob error and the error of the finished gear. A gear with smaller number of teeth is likely to have greater polygon error. Multi-thread hobbing is recommended for gears with number of teeth above 18. Ratio of number of thread in hob and the number of teeth in gear determines the cutting sequence between individual threads of hob and the teeth of gear. Whenever possible, the number of threads in hob is to be prime number mutually to the number of teeth in gear.

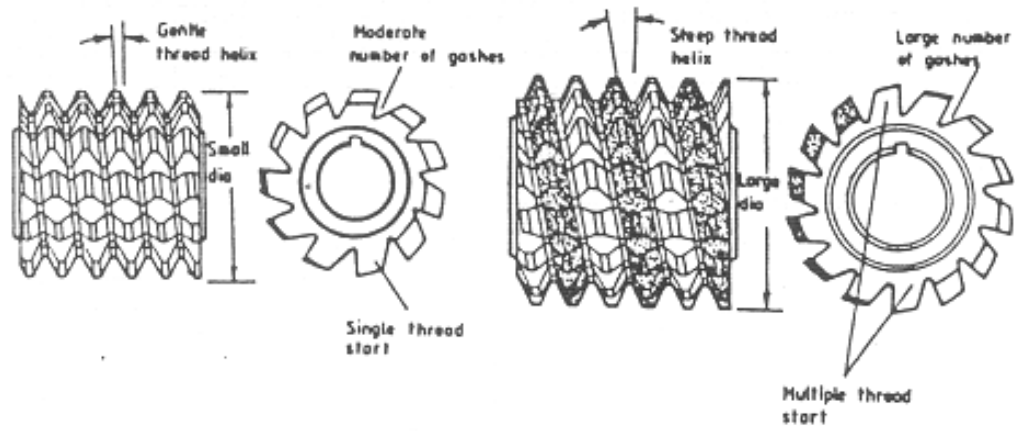

Fig. 4.63 Difference Between a Single- and Two- Thread Hob

The cumulative errors inherent in multiple thread hobs limited their use to roughing application. Now significant improvements in grinding technology, such as reduction index error, permit the manufacture of very accurate multiple-thread hobs. Accurate heat treat control has also contributed significantly. Multiple-thread hob is fast replacing the less productive single-thread hob. As a basic necessity for using multi-thread hob, it is to have a superior accuracy- of machine, hob mounting, and hob sharpening. However, manufacturing engineers still hesitate to recommend multi-thread hob for finish hobbing of extreme accuracy or sliding splines

**Throw-away hob** is a new type of hob with a diameter reduced to minimum for achieving high hob revolution per minute (rpm). The number of gashes is as high as possible at the expense of sharpenable tooth length, Fig 4.64. The increase in productivity is almost double. The

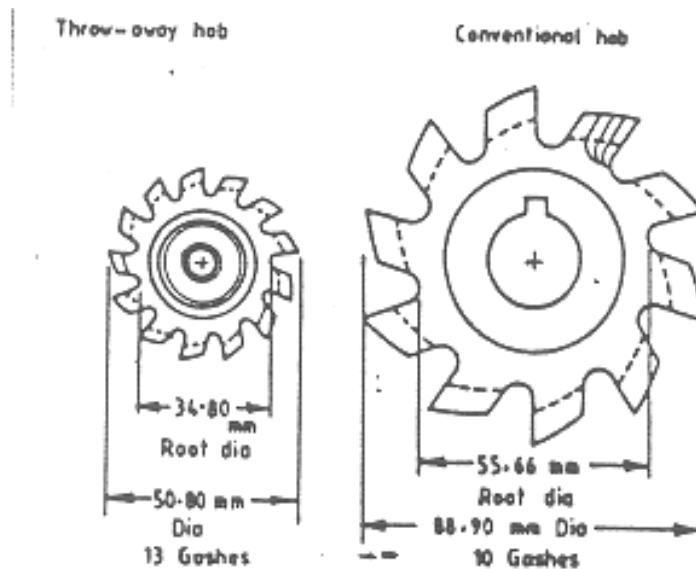

Fig. 4.64 Comparison of a Throw-away Hob with conventional hob

teeth, individually, are just long enough in circumferential length around the outside diameter of the tool to provide the required strength as well as tip and flank clearance. As the disposable hob is not resharpened, the machine adjustments are not required that is necessary with conventional hob after resharpening. The inaccuracies due to resharpening are eliminated.

### **Gear Shaper Cutter**

A pinion type cutter is used for shaping cylindrical gears. The cutter is basically a cylindrical gear whose addendum modification changes continuously along the face width from a positive value for a new cutter to a negative value for used cutter. The right and left flanks have the clearance angle on the reference cylinder. The basic rack tooth profile of the cutter enveloping surface must correspond to the basic rack tooth profile on the gear in the same plane. Flank clearance angle on the reference cylinder is 2 to 3 degree depending on the machinability of the material of gear. The front rake angle is normally 5 degree. On conventionally manufactured cutter, a constant tooth thickness and depth of cut can be obtained for the approximate designed life span of the cutter.

For gear shaper cutter, the trend is to use larger diameter and wider face width for improved stiffness and better tool life. The ratio of the number of teeth in the cutter and that in the gear, is an important factor for the accuracy of the gear. It is kept within approximately 5:1 to 6:1 to reduce the 'windup' in machine shafts causing spacing variations.

**Through-grind shaper cutter** ensures about 25% - 40% better performance by the way of extra tool life at about 15% extra initial manufacturing cost. In through grinding technique (Fig. 4.65), a reciprocating grinding wheel passes through the entire face width of the cutter and generates the tooth profile. Standard involute cutter manufactured by through grinding method will have extra larger face width. For cutter with modified involute form, say with tip chamfer and protuberance, through grind cutter has maximum possible tool life, as the modified form remains constant even after any number of sharpening. For conventionally

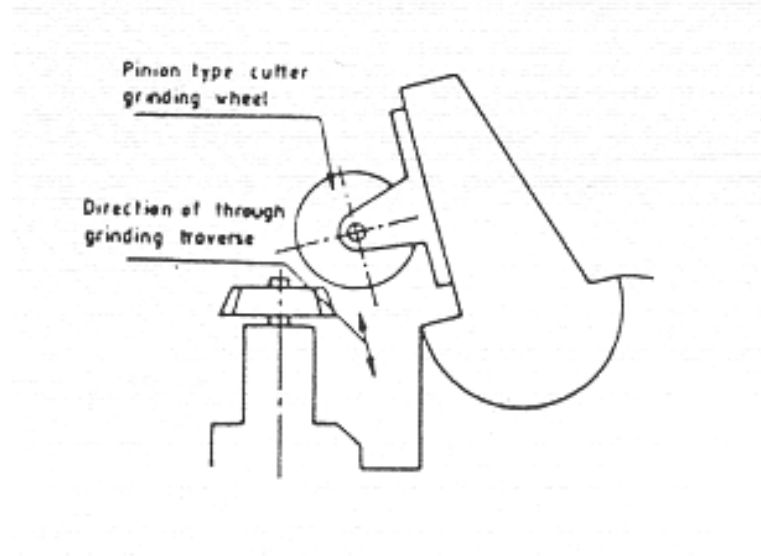

**Fig. 4.65 Through-Grind Technique of Producing Shaper Cutter**



manufactured cutter, the amount of tip chamfer and protuberance reduce, as the cutter width reduces after each sharpening. Through grind cutter is considered as high performance cutter. Because of its truer cutting geometry, it produces higher quality gears. Its longer tool life means a lower tool cost.

**Disposable shaper cutter:** For gear-shaper cutters, a new concept does away with sharpening altogether. The disposable wafer cutter transfers the concept of the disposable insert to shaper cutter. Instead of sharpening, the wafer concept discards a worn TiN (Titanium Nitride) coated HSS wafer. It is replaced by a new TiN-coated wafer, about 0.65 - 1.25 mm thick, of the exactly same diameter into the cutter assembly. Worn grinding wheels, loose machines, improper setups- all the common sharpening problems that introduce inaccuracies into the gear are eliminated. Besides eliminating sharpening, throw-away wafers mean the end of machine adjustments for stroke and for the reduction in radial size of shaper cutter due to grinding. Eliminating the need for stroke and centre distance adjustment eliminates a potential source of error. Unlike conventional shaper cutters, no compromise in tooth geometry needs to be considered. It provides the opportunity to use the best operating pressure angle, and cutting clearance angles for optimum performance and tool life.

One manufacturer simulates the cutting geometry of a solid shaper cutter and provides clearance angle to the cutting edge. After assembly in cutter body with the bottom clamp, the flat wafer distorts into a disc-shape as if a belleville washer and provides the concavity at the bottom face as in conventional cutter, Fig. 4.66. As the wafers are provided with clearance angle, it has a definite top and bottom that necessitates that wafers are produced on at a time.

Another manufacturer does not provide any backed off relief angle. The throw-away disc is a thin perfectly flattened cylinder before assembly in cutter body, Fig. 4.67. The cutting edges are perpendicular to the blank, and can be manufactured in stack. Both sides of the blade

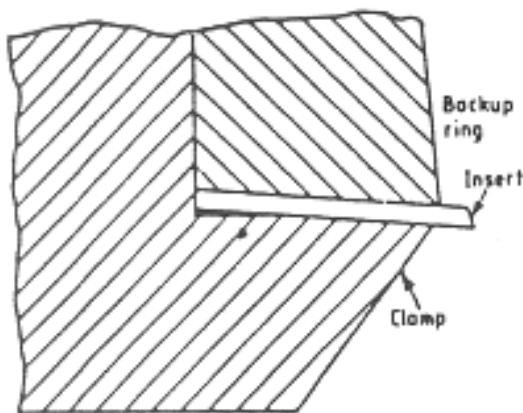

Fig. 4.66 Disposable Cutter (Maag-Pfauter) Shaving Cutter

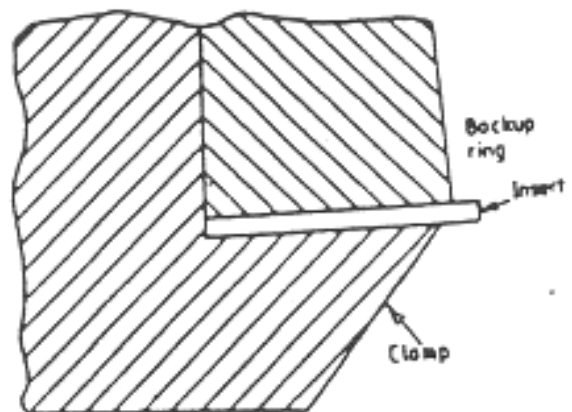
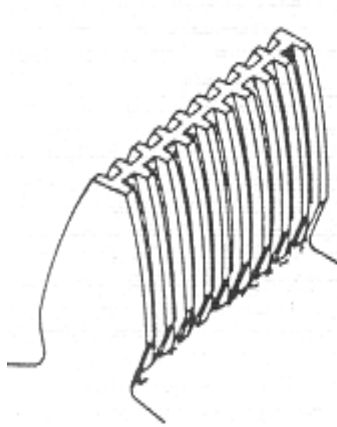

Fig. 4.67 Disposable Cutter from Fellows

are symmetrical and reversible. The disposable disc is supported by a holder. The holder with the same number of teeth as the disc is ground for the desired deflection angle. As the disc is clamped by the holder, the deflection of the disc gives the disc a negative face angle and also converts the disc into an usable cutting tool. By deflecting into a negative face angle, the outside diameter assumes a clearance angle equal to the deflection angle. Side clearance is also self-imposed by the deflection.

Shaving cutter is basically a spur or helical gear of teeth with a large number of serrations forming cutting edges, Fig. 4.68. Generally, these serrations are parallel to the profile of cutter teeth. Normally, annular serrations of shaving cutter will be satisfactory in parallel and diagonal shaving processes.



**Fig.4.68 Standard Shaving cutter**

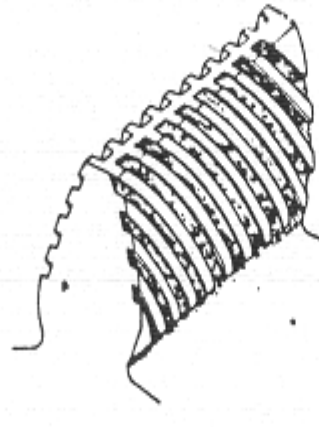

**Fig. 4.69 Helically Staggered Serrations**

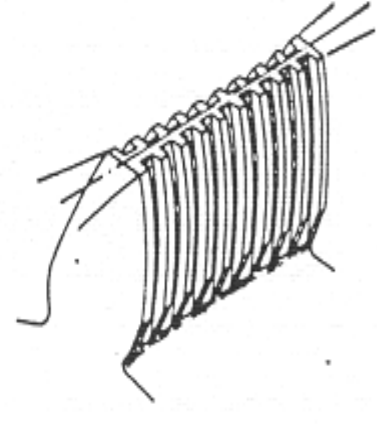

**Fig. 4.70 Negative longitudinally Crowning**

In underpass and plunge cut shaving operations, The longitudinal motion is smaller than the pitch of the cutter serrations in underpas and plunge cut shaving operations. The normal shaving cutter will leave certain portions of the tooth surfaces unfinished. A shaving cutter with helically staggered serration (Fig. 4.69) and negative longitudinal crowning (Fig. 4.70) over the total tooth surface. The contact ratios and specific sliding conditions are different with differences in number of tooth, and addendum modification coefficient, and result in tooth profile error. So the shaving cutter is usually different for every gear even with a difference in only number of teeth. Helix angle of the cutter at pitch circle diameter is selected to provide the desired crossed axes relationship for optimum guidability and cutting efficiency. Shaving methods decide the face width of the shaving cutter. For conventional method, the cutter width is standard. For diagonal shaving, facing width is influenced by diagonal angle with certain allowance (about 5 mm). For underpass and plunge shaving, the face width of the cutter is decided by the face width of the gear, crossed axes angle of gear and serration arrangement. The hyperboloid pitch surface of the cutter is fully in contact with the cylindrical pitch surface of the gear being shaved. In underpass and plunge shaving, cutter is to be modified by forming a negative replica of the desired gear teeth. Variation in contact ratio substantially affects the accuracy of tooth profile, as the meshing in shaving does not have a forced transmission mechanism. A contact ratio of about 2.0 provides nearly most stable meshing condition of cutter and gear. The cutter design must provide the same numbers of simultaneously intermeshing teeth on right and left teeth's surfaces, so that the distribution of the cutting load is uniform, Fig. 4.71.

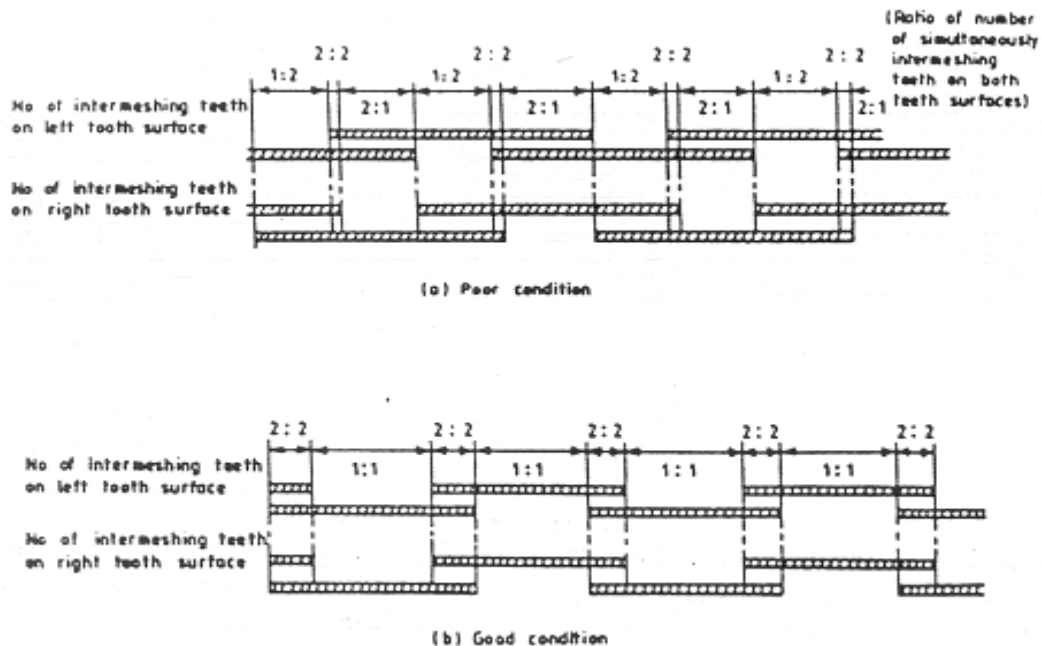

Fig. 4.71 Number of Simultaneously Intermeshing Teeth

Tool manufacturer develops the basic shaving cutter design. With sophisticated CNC shaving cutter grinding machine, the user develops the modifications on the teeth of the cutter to meet its performance requirements.

**Coating gear cutters:** A real revolutionary improvement has recently been achieved by Titanium Nitride (TiN) coating of gear cutting tools particularly hobs and shaper cutters using low temperature physical vapour deposition process. TiN coating provides a very high abrasion resistance, prevents built-up edge, reduces friction and erosion on cutting faces. So obviously the tool life is improved, and/or higher cutting parameters can be used to increase production. Besides, the surface finish of gear tooth profiles is better and consistent.

For gear cutting tools, flank wear (defined as periphery wear), corner wear, and lower flank wear on the relieved surfaces of a cutter tooth, are normally predominant. TiN coating reduces flank wear. In a newly coated hob even the crater wear is reduced, which is lost

after resharpener. As reported in one study, the tool life is improved upto 2-3 times for gear shaper cutter and 3-6 times for hob. Cutting speed and also feed can be increased by 20 to 50% achieving higher productivity.

Modern CNC hobbing and shaping machines with highly improved static and dynamic rigidity permit the application of suitable carbide grade for hob and shaper cutter. Compared to HSS, carbide hobs may result in 6-10 times more hob life and/or much less cutting time. Presently solid hobs are commercially available for lower modules, whereas carbide brazed hobs are in use for large modules. Generally, shaper cutters are carbide brazed. Multi-start carbide hobs will also become practicable to achieve perhaps the ultimate reduction in gear cutting time.

## HEAT TREATMENT OF TRANSMISSION GEARS

For transmission gears, the core of the tooth is to be soft and ductile for impact absorption without breakage during actual running whereas the surface of the tooth should be hard enough to resist wear. Surface hardening process includes:

- a) **Carburising** to enrich the work surface to desired depth with carbon
- b) **Quenching** to induce hardness and,
- c) **Tempering** to achieve improved toughness.

**Carburising:** The parts are heated in the furnace in an atmosphere containing one of the carbonaceous gases that are either supplied directly or produced by vaporisation of liquid hydrocarbon. Gas carburising is the preferred option with its many advantages. Carburising time to attain desired effective case depth may be any more reduced by increasing temperature. Firstly, any more temperature rise may cause problems related to maintenance of the furnace. Secondly, there will be the possibility of undesirable grain growth with higher temperature. A high degree of purity of the carburising gases is necessary to ensure against formation of oily soot. Variation in chemical composition of different gases is also undesirable for maintaining control for uniform quality. The carbon level in the furnace is measured and controlled to achieve the desired carburisation quality. Sophisticated measuring and controlling devices have been developed to automatically account for the influence of temperature and other relevant factors with the help of built-in programmable microprocessor.

**Quenching:** Carburising is followed with quenching to achieve the required hardness. For maintaining the high case hardness and low core hardness, the parts are allowed to be cooled to about 765<sup>o</sup> C, which is high enough to harden case but not the core and are quenched.

**Tempering:** Tempering must be carried out immediately after quenching that induces martensitic structure. Even an overnight time gap may induce cracks in hardened parts. In tempering, the quenched parts are heated again to a temperature below its lower critical temperature (about 710<sup>o</sup> C). The process relieves the structure of high residual stresses - first by precipitation of iron carbides from the unstable super-saturated solid solution - and then by diffusion of the carbides. Tempering must ensure exposure of all the gear surfaces for the required time at specified temperature. After tempering, the parts are brought to ambient temperature by air cooling.

Facilities in a typical heat treatment plant for transmission gears comprises of -

1. Carburising and hardening furnaces.
2. Tempering furnaces.

3. Washing facilities.
4. Post heat treatment facilities e.g.
  - a) Shot blasting machines.
  - b) Shot peening machines.
  - c) Phosphating unit.
5. Other special facilities
  - a) Induction hardening/annealing equipment.
  - b) Flame hardening/softening unit.
  - c) Plug or press quenching machines.
6. Quality Control equipment.

Depending on the volume of production, a decision is made to use either batch or continuous furnaces. In batch type furnace, the work is charged and discharged as a single unit or batch. In continuous furnace, workpieces enter and leave the furnace as units in a continuous stream.

Batch type furnaces may be of 'Straight through' or 'In-out' design, Fig. 4.72

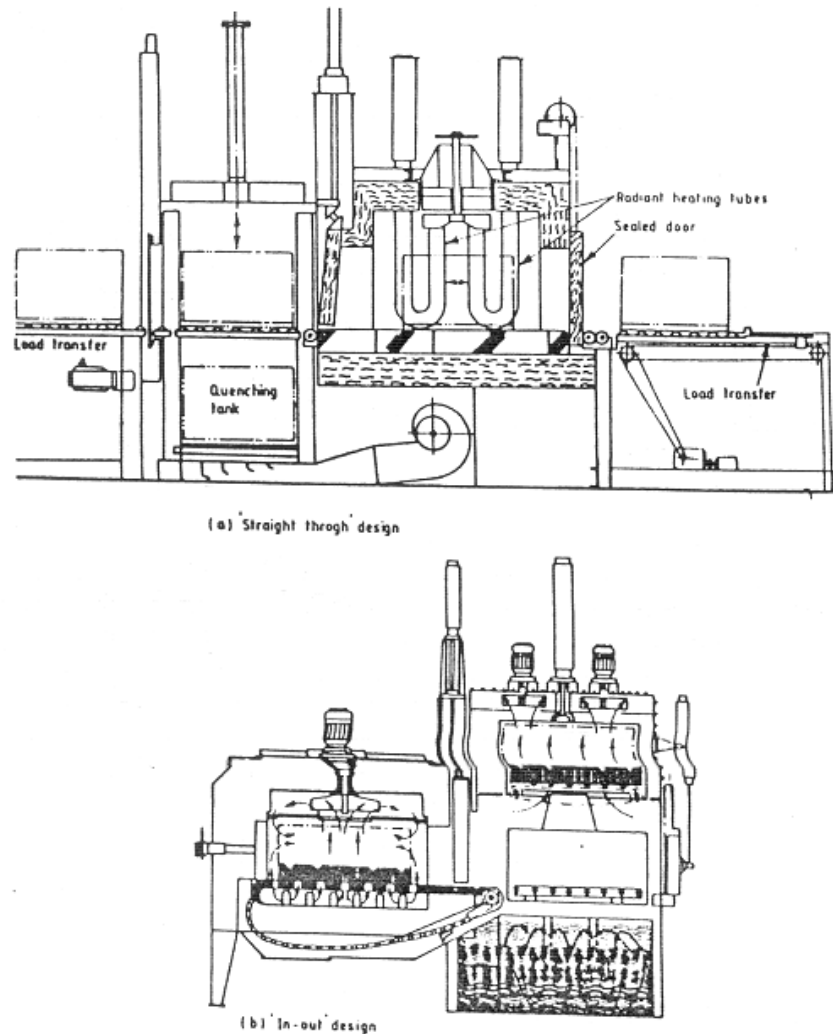

**Fig. 4.72 Batch type Sealed Quench Furnace**

Straight through sealed quench furnaces have certain advantages over conventional 'in-out' type furnaces:

- A new charge can be brought into the furnace chamber immediately after the charge has been transferred into the cooling chamber.
- Handling system is straight and easy. Chance of mixing of treated and untreated charges is eliminated.
- Each time the furnace is loaded, the gas atmosphere in furnace is reconditioned. Thus the control of gas atmosphere is precise without any operational difficulty. The feature makes the furnace more flexible for different type of heat treatments that have to be performed in sequence.
- For inspection and/or repairs, doors at both ends can be opened to speed up the cooling and purging of the furnace. Accessibility is also better.

'In-out' design is recommended where availability of floor space is a limiting constraint. The degree of utilisation of 'in-out' version is also lower.

A number of batch type furnaces can be installed for carburising (with quenching) along with a suitably located washing machine and tempering furnace. A motorised charging trolley can move the material trays to all of them in a manual/semi-automatic/or fully automatic mode..

For a fairly good size transmission plant with a production rate of 90-100 Kg/hr or above, a semi-continuous or continuous pusher type furnace, Fig. 4.73 can be safely recommended. The furnace comprises of a heating up zone, carburising zone and diffusion zone. The proportion of the last two zones, is approximately 2:1.

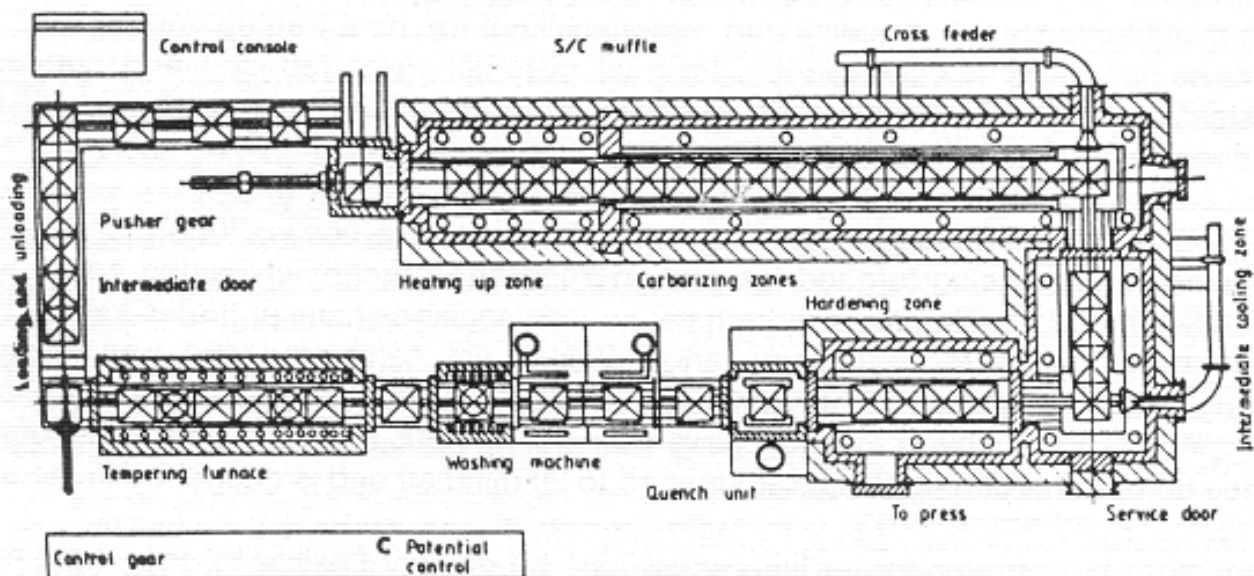

Fig. 4.73 A Schematic Arrangement of Continuous pusher Type Furnace

Furnace design incorporates the features to eliminate the possibility of air infiltration and contamination of the carburising atmosphere. A gas curtain of sufficient flame size prevents ingress of air when the door is opened to take in or discharge the trays. A suitable intermediate partition cuts off the heating up and diffusion zones from the carburising zone for

better temperature control and control of furnace atmosphere. Hardening zone generally comprises of only a single temperature zone. Temperature uniformity of about  $\pm 5^{\circ}\text{C}$  is maintained through suitable controls.

Gas circulating units ensure thorough mixing of the added carburising gases with the carrier gas from endogas generator. It results in uniformity of carbon potential in carburising and diffusion zones. Suitable oxygen probe or more sophisticated measuring, recording and controlling instrumentation closely monitors and maintains the desired carbon potential in carburising and diffusion zone. A carbon potential difference of 0.2% to 0.3% carbon is maintained between the zone by controlling the number of revolution of the fan or doubling the partition drop arch. Sometimes, a continuous furnace with a circular section instead of the conventional square section is used for better energy saving and further quality improvement

Temperature of oil bath of quenching tank is between  $50^{\circ}\text{C}$  -  $95^{\circ}\text{C}$ . Sometimes, a hot oil bath with temperature between  $140^{\circ}\text{C}$  -  $200^{\circ}\text{C}$  is preferred. The type of steel determines the quenching bath temperature for better controls of amount of distortion. A provision for controlled oil circulation is made in the bath. Oil circulation is speeded up (almost twice) when the worktray is in the bath. Temperature of the oil bath is controlled by passing the oil through an external water cooled oil cooler. The controlled atmosphere during quenching improves the life of oil bath considerably.

With many advances, the quality and repeatability of the heat treated components from gas carburising furnace are excellent. Thermal distortion gets reduced and controlled to a constant level. Similar effort made in construction of continuous furnace has also yielded good results.

A new type of continuous furnace has a combination of a conventional continuous furnace and a batch processing furnace for cooling zone and hardening/soaking zone. A partition separates the carburising furnace from the cooling/soaking chamber that is kept at hardening temperature. After the carburising and diffusion are completed, the tray is sent to the cooling/soaking chamber. The workpiece is rapidly cooled to the hardening temperature. Workpiece is then moved to quenching chamber without any hold time. The workpiece is cooled down to hardening temperature in 15 to 20 minutes and is quenched immediately.

Today, the heat treatment facilities must also be equally flexible to case harden different parts to different case depths at the same time in the same furnace. In one of the transmission plant of European Automobile manufacturer, a flexible furnace system, Fig. 4.74 has been used. Trays of components of each type are regulated by pre-programming in rotary hearth furnace for different carburisation time. The conventional pusher type furnace (2) brings the load to carburising furnace. The indexing of rotary hearth furnace (3) is in any number of steps in either direction and is pre-programmed. From diffusion furnace (4), components may be removed for press hardening or to an oil bath for quenching or to gas cooling. The furnace systems are totally automated.

**Shot peening:** High speed gears of automotive transmission are shot peened on the teeth to improve the fatigue strength during bending. Shot peening is a cold working process.

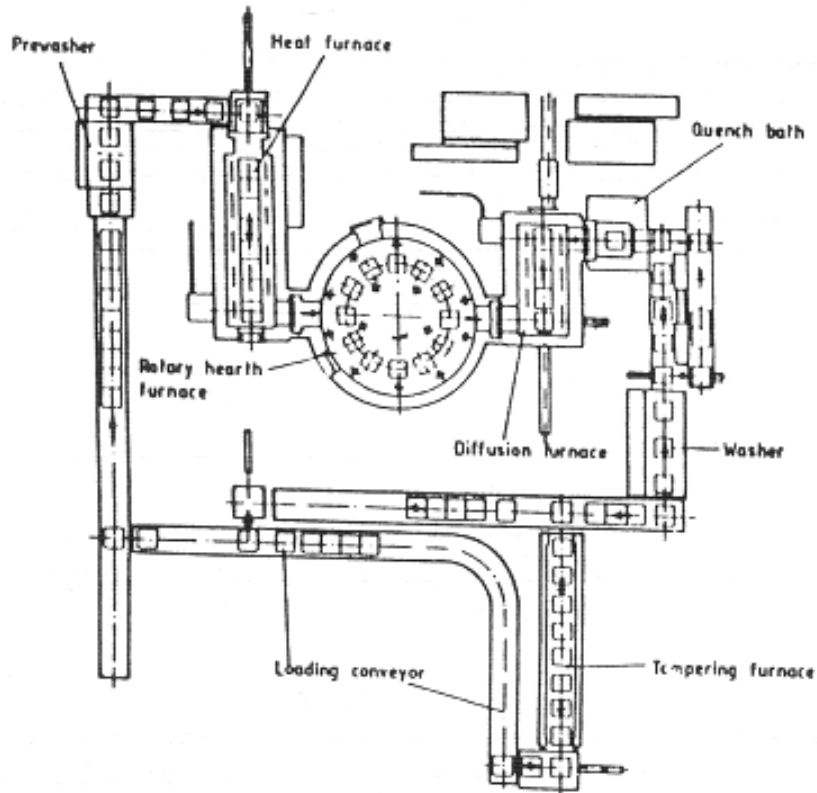

Fig. 4.74 A Flexible Gear Heat Treatment System

Compressive stresses are induced in the exposed surface layers by the impingement of a stream of shots at high velocity and under controlled conditions. The machines are basically similar to the shot blasting machines with more stringent control. Shot cycling system consists of devices to separate and remove the fines and spent (broken or undersize) shot and to add the required amount of new shots. Work fixturing is more critical to permit effective exposure of the desired critical areas to the blast streams. Peening intensity depends on the velocity, hardness, size and weight of the shot pellets and by the angle at which the shots impinge against the surface of the workpiece. Intensity is expressed as the arc height of an Almen test strip at full coverage. Arc height is a measure of the curvature of a test strip that has been peened on one side only.

Other facilities in a modern heat treatment plant may also include other equipment, e.g. induction heating, hardening or softening machines, flame hardening units, electron-beam welding, and a metal laboratory.

### Effect of Heat treatment:

#### Gear size and accuracy

Heat treatment processes produce changes in tooth geometry. The gear profile exhibits a drop after heat treatment depending on the module. Helix angle of gears becomes decreased, as the helical tooth tends to straighten. The gear with higher helix angle will have more increase in lead. There is certain growth or shrinkage on the pitch circle diameter (measured over pins or balls) of the gears. Pitch circle diameter of inside splines shrinks and



exhibits out-of-roundness error. The pitch circle diameter increases in case of solid external gears. Some important factors responsible for these changes are as follows:

- Hardenability of gear material.
- Forging practices.
- Cutting tools used in machining e.g. shaving cutter, broach etc.
- Work support and pattern of loading in carburising.
- Work location on a tray.
- Temperature and its uniformity and control of carbon potential and uniformity of carbon absorption and diffusion.
- Difference in cooling speed, cooling agent and necessarily design of hardening and quenching units.

Main objective of the development work in heat treatment process aims to achieve a predictable and controlled distortion and dimensional changes. With established heat treatment changes, it is possible to provide allowances at soft finishing stages to achieve the final dimensional tolerances for transmission gears. Overpin size of transmission gears after shaving is kept less to take care of growth. Helix angle during shaving is kept less to achieve helix desired after heat treatment.

#### **On Microstructure of Case and Core of Gear Teeth**

Normally, a good and acceptable microstructure of carburised and hardened case should consist of a hyper-eutectoid zone of tempered circular martensite that contains not more than 5% retained austenite. Down the depth, the martensite diminishes and becomes blended with a core microstructure of blocky martensite containing bainite and/or fine pearlite depending on the hardenability. Grain boundary network carbides or areas of massive carbides are not acceptable. Transformation products of pseudo- martensite, untransformed pearlite and ferrite that indicates improper heat treatment, are not acceptable. A poorly transformed soft core structure can not withstand the load coming on the case during service.

Finally, better control of atmosphere, carbon potential and temperature for gas carburising furnaces have brought uniformity of quality regarding case depth and distortion. Vacuum and plasma carburising are upcoming processes for ensuring consistent and clean quality. However, on-line selective direct heating processes, i.e. Gradient Profile Induction Hardening will substitute the conventional heat treatment of gears. Laser and Electron-Beam hardening will follow as the state-of-the-art technology to provide gears with minimum distortion.

#### **HARD GEAR FINISHING**

Heat treatment distorts the bore, deforms the outside diameter, causes deviations from the soft finished dimensions and geometry. Tooth flank becomes rough because of scale formation in heat treatment, shot blasting and shot peening. Carburising usually results in a drop in profile, e.g. increase in pressure angle. Amount of drop varies with pitch and case depth. Carburising also causes unwinding or decrease in the helix angle. For thicker gears, the unwinding will be less. All these variations produced during heat treatment generate the necessity of finishing the hardened gear to bring back the dimensional accuracy as well as tooth quality up to the required specifications. Finishing of hardened gears comprises of :

1. Grinding of external or internal bearing surfaces.
2. Finishing of gear tooth flank.

#### **Multi-surface Grinding of Round Gears**

Generally, the bore, faces and synchronising cone of main gears require grinding with respect to pitch circle diameter of gear teeth to achieve the size and geometric relationship for correct final assembly and desirable performance. There are many alternatives for grinding the different surfaces using one or more special and/ or conventional machines. A CNC or special internal grinding machine may be used to achieve inter-relation tolerances of various surfaces. All the surfaces can be ground in one clamping. Naturally, on a CNC machine with a single wheel, the time cycle is more.

In internal grinding operations, the size of wheels limits its life. Repetitive wheel change is unproductive. Solutions being sought are:

- (1) switching over to better abrasive, e.g. Cubic Boron Nitride wheel
- (2) incorporating accurate and rigid quick tool change system in grinding spindle.
- (3) providing automatic tool changer for replacing the worn wheel by a new one

Honing is an alternative to grinding to finish the bore. Honing spindle with abrasive stones rotates and reciprocates simultaneously in the bore keeping the gear stationary, and produces fine finish with cross hatch pattern that helps in retaining lubricating oil. Size and geometric accuracy of the bore obtained are excellent. To have better wear life and to eliminate heat build-up during gear shifting, the cone of mainshaft gears is super-finished to achieve desired surface finish upto Ra 0.08-0.1 micron along with improved roundness.

### **External Cylindrical Grinding of Shaft Gears**

Because of the non-uniformity of the metal structure, extreme variation in cross sectional area over the length, and uneven heating and cooling during the heat treatment, shaft gears deform and bend. A straightening becomes essential.

Heat treatment causes dimensional deviations of the centres in the shaft gears because of oxidation, scale and distortion. Roundness and concentricity of the centres supporting the workpiece, influence the quality of grinding operation. For grinding with non-rotating centre in work spindle, the centre holes in the shaft require grinding to achieve low concentricity error on different diameters of the shaft.

A number of diameters of shaft gears are ground to different tolerance limits on both sides of a collar or of a gear element. A plain or angular head cylindrical grinding machines applying plunge and/or traverse mode is selected. Naturally, grinding different diameters in single set-up either by CNC single wheel or multiple wheel gives consistent and superior geometrical accuracy or straightness and concentricity. In one application, a CNC angle head cylindrical grinding machine completes a transmission mainshaft in two set-ups. On the other hand, a conventional grinding machine would have required 11 setups, and total grinding time would have been almost double. Multiple wheel or special extra wide wheel certainly takes lesser time. However, the wheel becomes several times wider with correspondingly large copy dressing system. Wheel spindle becomes very heavy and difficult to handle. The work involved in changeover of the wheel spindle and arrangement for handling of the heavy wheel assembly becomes more difficult as well as time taking. Unless the production volume justifies the use of multi-wheel grinding machine, it will not be a cost effective solution.

Some bearing diameters of the shaft gears may require superfinishing. In superfinishing operation, a stone oscillates over the diameter as the component rotates.

## **FINISHING OF TOOTH PROFILE OF HARDENED GEARS**

Tooth profiles of a gear require finishing after hardening:

- to eliminate nicks and burrs caused during transportation and handling
- to improve the surface finish damaged during heat treatment and blasting.
- to reduce or eliminate errors related to gear quality and originated in pre-finishing operations including heat treatment.

Finishing of tooth profile is intended to improve the performance of gear pairs :

- It improves the contact area of flanks to a large percentage.
- Complete lubrication between tooth flanks is ensured. Metal to metal contact of flanks is greatly reduced or even eliminated due to low roughness depth. This, in turn, means no pitting and no metal removal that causes bearing damage.
- Running noise becomes negligible and so the unnecessary operations like matching of gear pairs, noise testing and manual damage removal are not required.

Processes used for finishing of gear profiles after heat treatment are as follows:

1. Rotary honing/fine finishing -
  - a) **External** - with a helical gear shaped honing tool driven by the gear.
  - b) **External** - with a worm pinion shaped honing tool driving the gear.
  - c) **Internal** - with a large honing tool with internal teeth driving the gear.
2. Hard finishing
3. Grinding -
  - a) Form grinding with a single formed grinding wheel.
  - b) Generating grinding with single or two formed wheels.
  - c) Form grinding or generating grinding with worm type wheel.

4. Skiving with special carbide cutter.

### Rotary Honing - External

In one system of external honing termed as 'fine finishing', the gear is driven while the tool is braked, Fig. 4.75. The machine configuration is very simple with a worktable with a motor driven tailstock. The tool head is attached to a vertical slide movable in two axes. After finishing one flank, the rotation is reversed to finish the second flank. On both the flanks, the direction of finishing is from the root to the tip. Finishing is due to crossed axes mating of tool and gear at constant centre distance. Geometry desired in the gear is put into the finishing tool with dressing master gear. With a coated dressing master gear in place of gear, the fine finishing tool is dressed in one normal working cycle. The setting is restricted to the centre distance and the crossed axes angle.

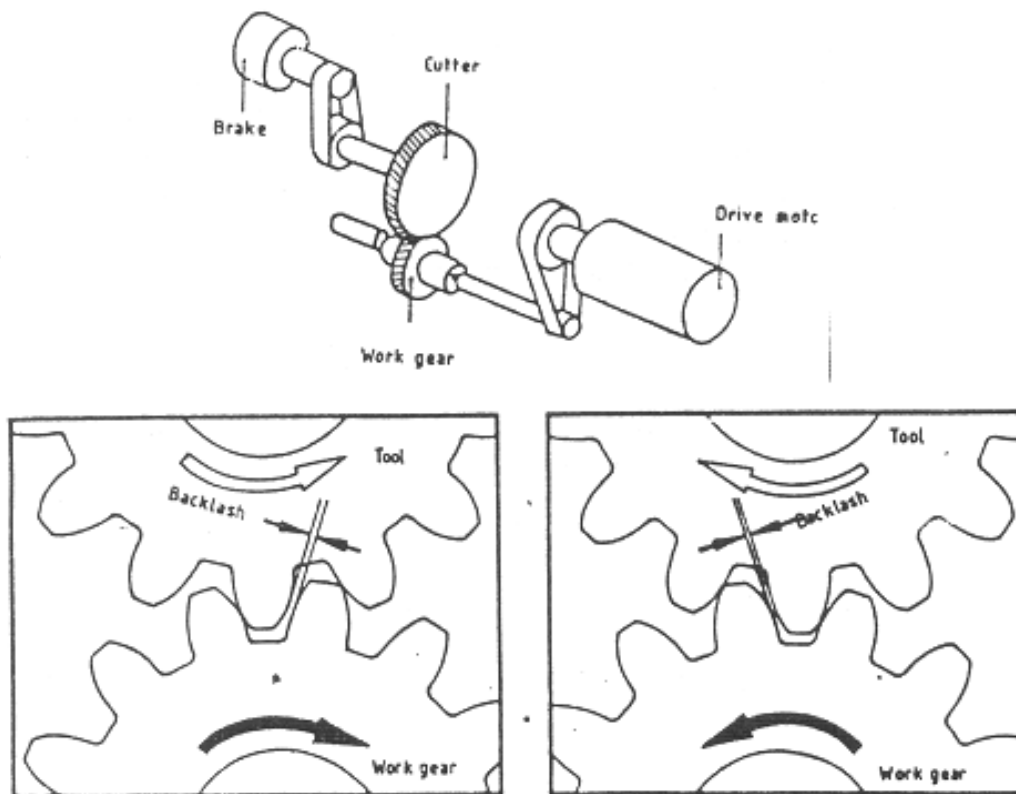

Fig. 4.75 A Fine Gear Finishing Technique

### Honing with worm shaped wheel

A honing tool in shape of a worm pinion meshes with the gear roughly at right angle. The honing tool drives the gear as it rotates. The straight sided thread flanks of the honing tool generate an involute curve on the mating gear. The honing tools of urethane-and-epoxy matrix are soft enough to yield to the gear profile but hard enough to hold their shape under pressure. The tool rotates at a surface speed of 600 metre per minute that is almost 3-4 times higher in comparison with the honing tool working on crossed-axes principle. Higher speed is

considered as the basic reason for efficient corrective cutting and better surface finish. Once the tool is worn to about 0.50 mm, it is sharpened on a separate machine built on the principle of a thread grinding machine. One honing tool may be used upto 20 sharpenings. The same sharpening machine can even produce a honing tool from a plain cast urethane-matrix cylinder.

The honing machines generally operate in two modes - (a) with backlash and (b) in tight mesh. In backlash mode, it mainly removes nicks and damages. It cuts one flank of each tooth of the gear, and then reverses to cut the other flanks. Setting of centre distance is not critical. In tight mesh mode, the honing tool finishes both the flanks in a single pass, and affects profile corrections.

#### Rotary Honing - Internal

The process uses a large size internally toothed honing stone on a cross slide in feed system, Fig. 4.76. The honing stone axis is varied to match the required crossed axes angle. The gear is held between centres on the table. The table can have longitudinal back and forth traverse for longitudinal honing of gear with larger width. The true running accuracy between centres is kept below 0.002 mm for a good honing result. Honing oil is used only to rinse and clean the pores of the honing stone. The crossed axes angular configuration results in a grinding motion that slides from the tip to the root.

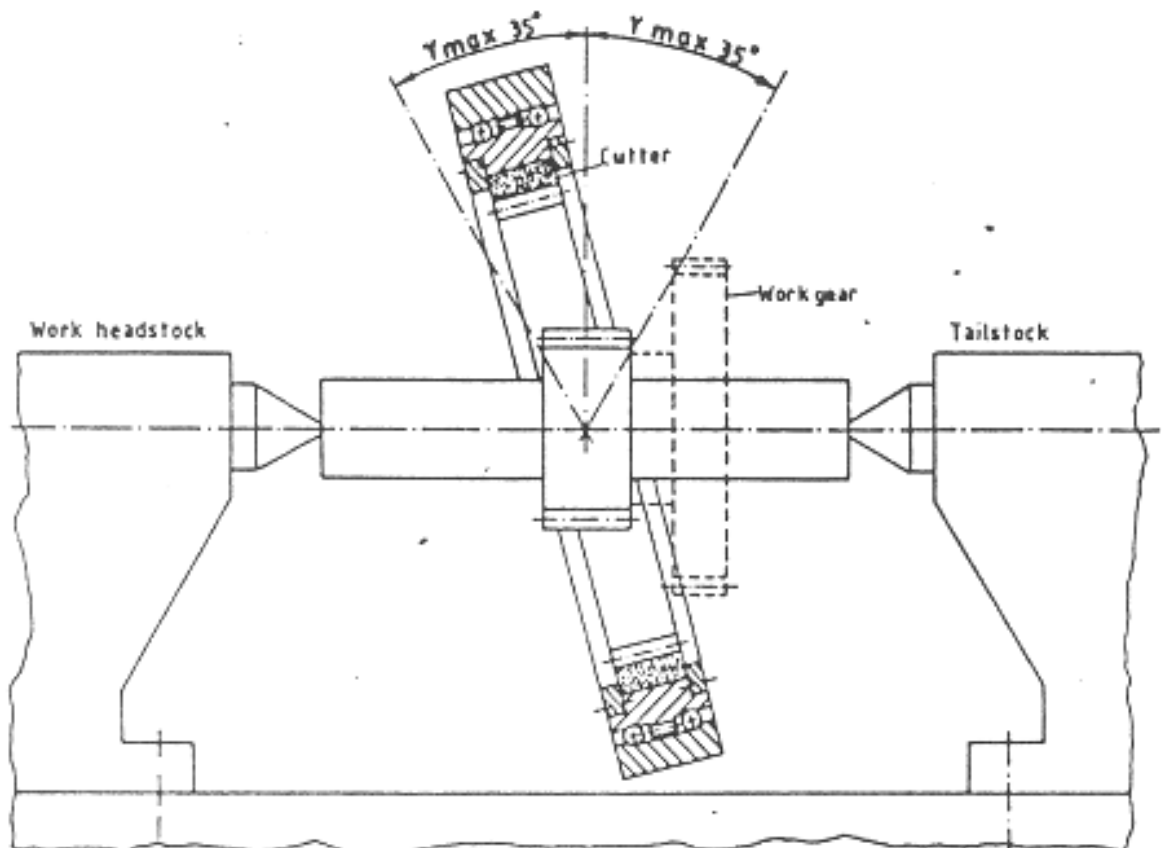
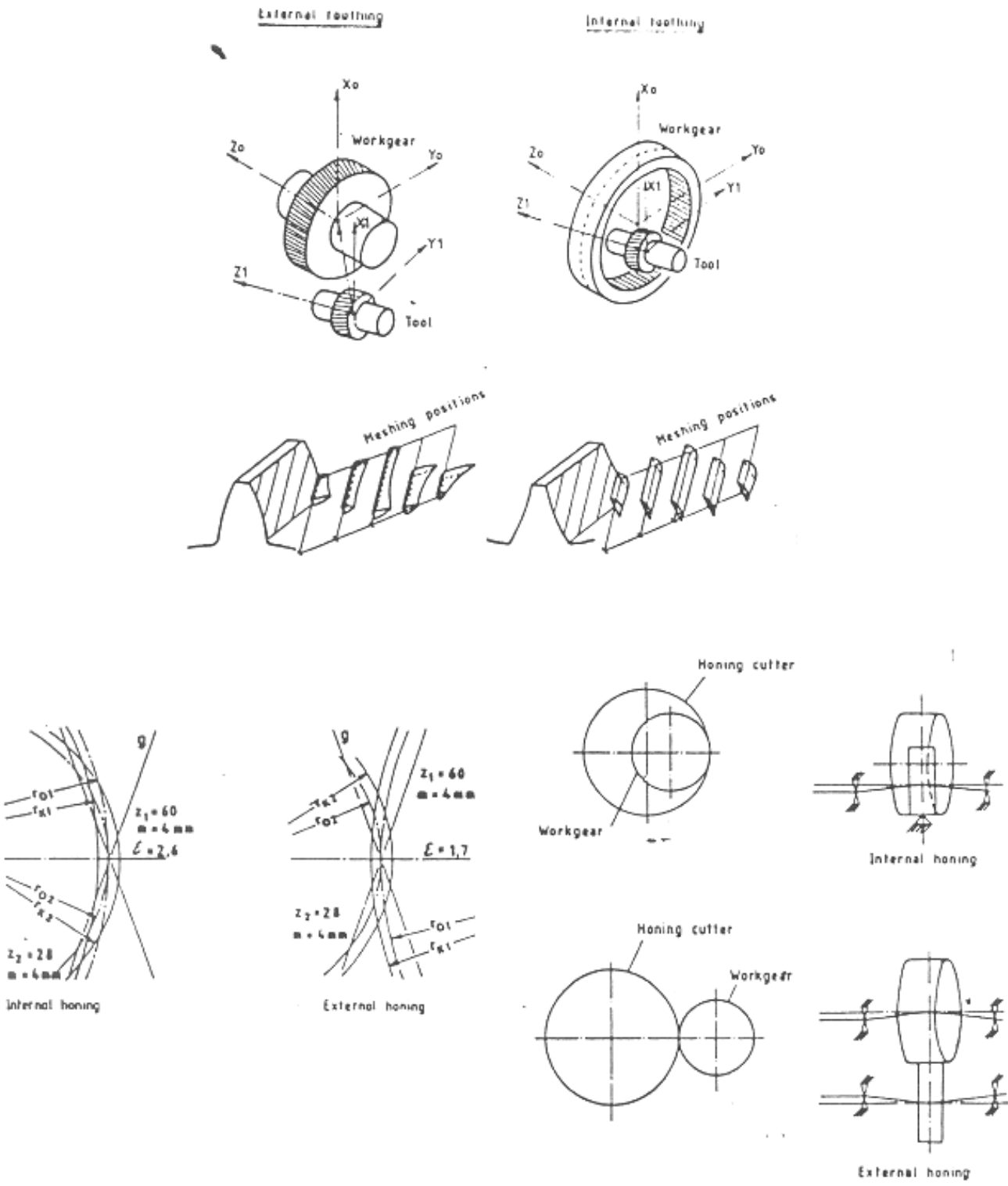

Fig.4.76 Internal Gear Honing System

Honing with internally toothed cutter has certain advantages over externally toothed cutter, Fig. 4.77.



4.77 Different Advantages of Internal Gear Honing over External one

1. Internally toothed honing stone results in higher traverse contact ratio with respect to external honing. It results in increased correcting action. This higher ratio gives
  - ✓ balanced contact pressure conditions.
  - ✓ good tooth form.
  - ✓ longer honing stroke.
  - ✓ reduced adjacent pitch error and accumulated pitch error.
  - ✓ reduced radial run out.
  
2. The force of the honing action with the hollow honing stone is directed to the rigid parts of the machine bed. As it does not involve any flexing shafts, a higher accuracy may be maintained.
  
3. The teeth of an internally toothed honing stone have a thicker base than the teeth of externally toothed stone. It results in higher stability and higher resistance against breaking. With a better stability of the teeth, the correcting action is better (for removal of damage or hardening distortion).

Honing stone is of synthetic resin bond and is moulded employing a gear with external teeth. Different diamond dressing wheel will be required for different module and pressure angle. These diamond dressing wheels are setup to reprofile the worn honing stone to about 0.01-0.05 mm.

Characteristics of gears honed with internally toothed stone are:

- Damage and burrs on tooth flanks caused by poor handling and transportation or generated during preceding operations are removed.
- Hardening distortion can be removed or reduced upto 0.02 mm per flank.
- Average roughness value Ra can be reduced to 0.2 micron.
- Machining traces, run diagonally from tip to the root of the teeth and provides better lubrication.
- Flank corrections (tip relief, crowning, taper) can be easily incorporated
- For reduction in radial runout and pitch error, the runout of pitch circle diameter of teeth with respect to bore before honing is to be controlled within 0.03 mm TIR (Total Indicator Reading). Quality improvement may be from 2 to 3 DIN grades depending on the quality of the gears before honing.

If this runout is more, the pitch error improvement may be about only 1 DIN class. Beyond 0.08 mm TIR, perhaps the involute improvement may be negative.

## **HARD GEAR FINISHING**

Noise generation from gear teeth in mesh is affected by meshing errors, Fig 4.78, under running condition. The ill-effect of meshing errors may be nullified through various tooth surface modifications.

Fine finishing (or honing) processes for tooth profile can not generate definite flank. The stone follows the geometry produced in pre-honing operation. It removes material from the flanks according to the irregular distribution of pressures and velocities. So the material removal for possible correction will only be in a range of a few microns or otherwise the flank geometry will be adversely be affected

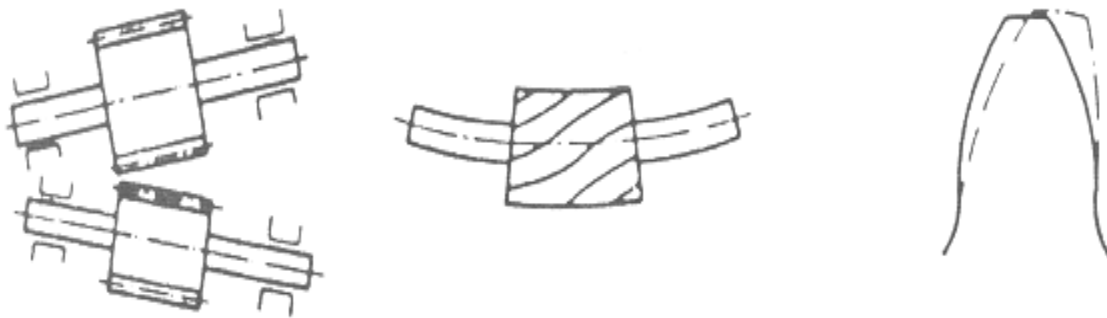

**Position of axes**

- Deformed housing
- Yielding bearing
- Temperature
- Assembly errors
- Production Tolerances

**Shaft Wheel**

- Deformed shaft
- Torsion
- Temperature

**Tooth**

- Deformed tooth
- Flattening
- Temperature
- Rigidity

**Fig. 4.78 Meshing Errors of Gears**

A stock removal of about 50 to 100 microns per flank is necessary to produce a specific flank geometry based on prefinishing operation. It demands a constrained mesh relationship between the stone and the gear. The helical gear shape cutter and the gear are mounted coaxially on the spindles with helical master gears, Fig. 4.79 in hard finishing. The master gears serve to guide and support the working flanks. The whole system provides high torsional rigidity and dynamic transmission. The material removal is by a relative tangential displacement obtained through contact of flanks of both gears beyond the nominal centre distance.

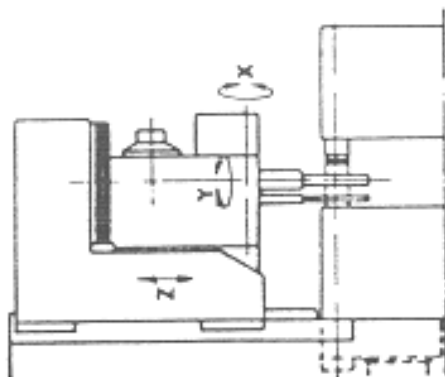

X - Tangential adjustment

Y - Tool head rotary adjustment

Z - Vertical slide motions

**Fig. 4.79 Mechanism of Hard finishing and the Machine**



The hard finishing machine is very rigid with vibration free construction. During a hard finishing cycle, Fig. 4.80, the vertical cutter slide moves down to a predetermined position to move the teeth of the work and tool into contact. After establishing the point of contact, the vertical slide moves up again to start position. The clutch is engaged giving a firm linkage between the master gear set and the gear/tool set. The tool starts rotating. The vertical slide is fed downward in programmed steps until the specified centre distance is reached. The working flanks are hard-finished. After a brief dwell, the vertical slide withdraws itself in rapid to start position. As a constant base tangent length on all gears is to be obtained, the hard-finishing tool is rotated through a minute amount relative to master gear before the second flank is hard-finished. Adjustment is done through CNC unit as the amount of adjustment increases with increasing tool wear.

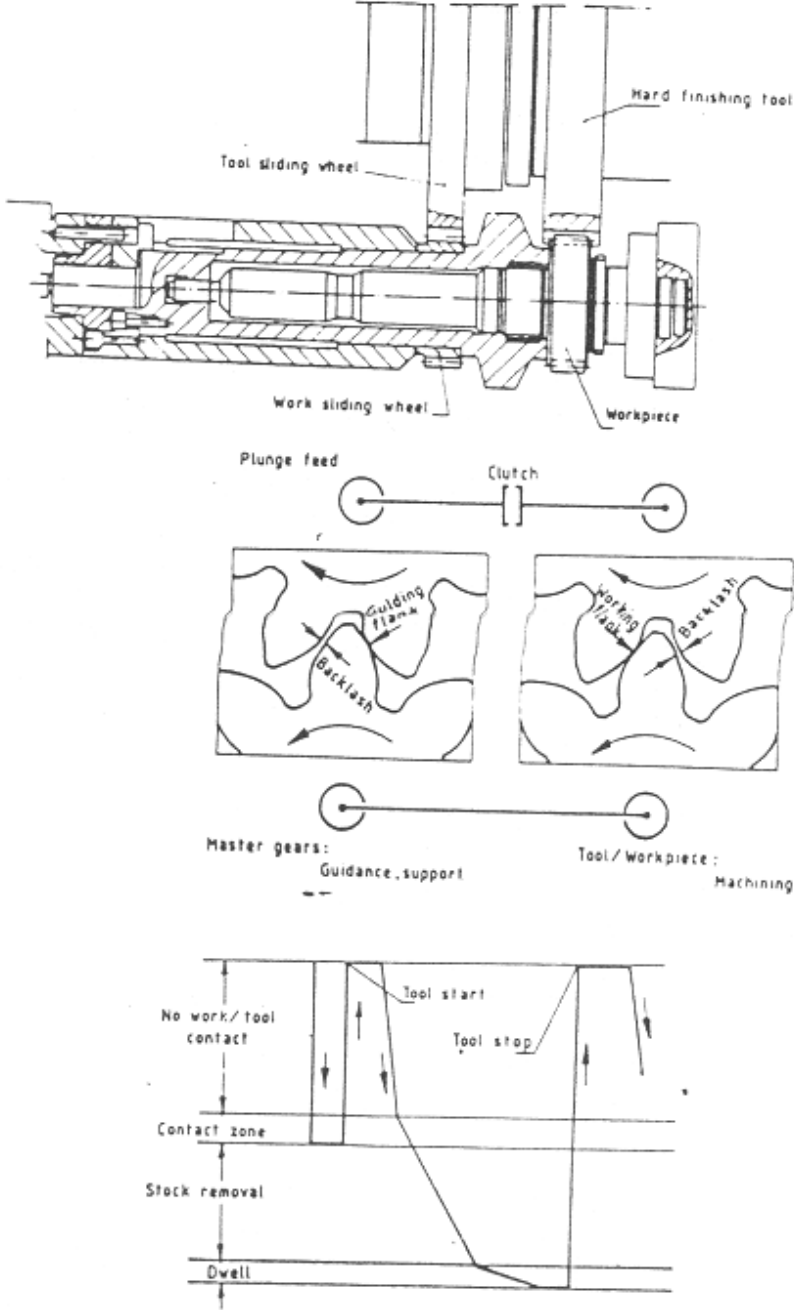

Fig. 4.80 Hard Gear Finishing Cycle

The accurate flank profile of the tool is obtained by a diamond dresser. As coated, the cutter flank profile is precisely similar to the desired flank profile of the gear. The hard finishing machine is CNC controlled that permits the optimisation of the process parameters. Tooth quality grade 9 (as per DIN 3962) generally obtained after gear cutting and heat treatment is improved to quality grade 5-6 DIN by hard finishing.

### Gear Grinding

Various gear grinding methods may be employed depending on productivity and quality desired, Fig. 4.81. Generally, form or generation grinding by a single formed wheel (or two single formed wheels) is time consuming. With the advent of continuous generation grinding method using a single start or multiple-start grinding worm, the process has become very fast. Continuous shifting permits high material removal rate. The profile of the grinding worm corresponds to the desired tooth profile of the gear. The point contact between grinding worm and tooth flank is maintained throughout the grinding. The rotating worm meshes continuously with the teeth of the gear and produces the involute tooth profile by means of innumerable trace cuts. The gear moves axially in several passes past the grinding worm. For high production setup, one roughing and one or two finishing passes are necessary. Axial shifting of the grinding worm to an unused portion of its profile before making the finishing passes ensures consistent quality. Cutting occurs in both directions of the stroke of the gear. Coolant is used to cool the point of contact of the grinding worm and the gear. The grinding worm is regularly and automatically reprofiled with a diamond coated gear with an approximate life of 3000 dressing operations. Setup change hardly takes about 30 minutes. Gear grinding eliminates soft finishing by shaving. With the continuous generation grinding, even protuberance hobs/shaper cutters may not be required for gear cutting. Upto module 3, a 2-start profiled grinding worm may be used increasing thus the output by 100%. Necessary modifications in profile and lead can be easily done. Presently with CNC control grinding machines are highly productive. In continuous form grinding method, axial feed movement is not required. The whole width of the teeth can be ground by providing a line contact between the grinding wheel and the gear over the entire width of the teeth. The ground gears are more accurate and of better surface finish. Accuracy of tooth spacing is high. Involute accuracy is generally equivalent to AGMA class 13 /DIN 4-5 /JIS O-1 or even better.





CONTINUOUS GENERATING GRINDING			FORM GRINDING	
Discontinuous (Indexing)		Continuous	Discontinuous	Continuous
				
Disc type grinding wheel	Double taper grinding wheel	Grinding worm (rack profile)	Single rib profile grinding wheel	Grinding worm (globoid profile)

Fig. 4.81 Various Gear Grinding Methods

## Hard Gear Skiving

Gear skiving is another successfully used process for finish machining of the tooth flanks of case hardened automotive gears. The process is based on crossed axes continuous generating principle, Fig. 4.82. The axis of tool and gear are positioned at the crossed axis angle. As the cutter and gear rotate, the cutter progressively advances parallel to the work axis. The gear rotates simultaneously by an additional amount relative to the cutter. The interaction of both the movements results in a screwing motion that removes metal from the tooth flanks.

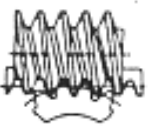
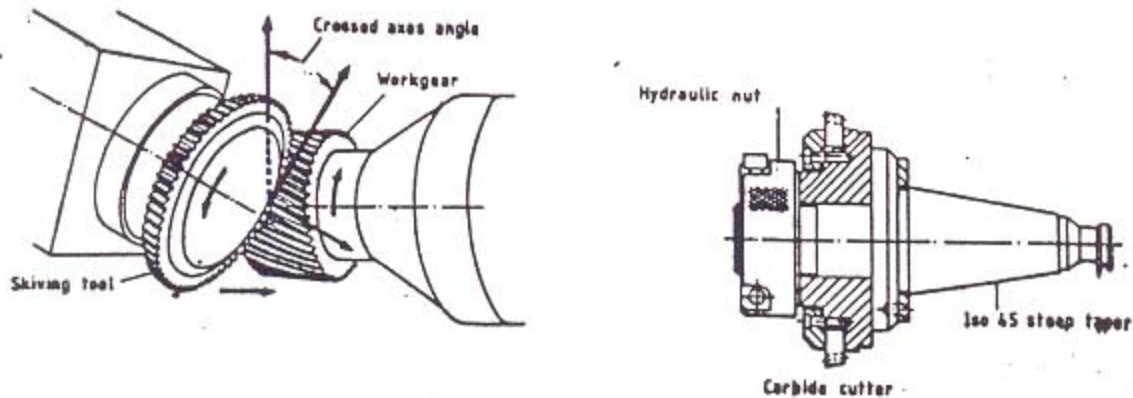

Fig. 4.82 Hard Gear Skiving Principle and Cutter

The carbide skiving cutter is very much similar to a shaper cutter. Stock left for finishing is between 0.07 - 0.13 mm per flank depending on distortion in heat treatment and case depth desired. Hard gear skiving eliminates the shaving for soft finishing gears. Skiving corrects all errors on flanks introduced generally in earlier operations - shaving, heat treatment, face or journal grinding.

Hard gear skiving machine is basically a CNC hobbing machine. An electronic control automatically aligns the teeth of the cutter with the gaps of the gear teeth. The process is very fast with a cycle time of less than a minute.

With hard finishing, gear grinding and hard skiving, the processing sequence of gear manufacturing undergoes a drastic change. Shaving is eliminated. A gear honing may be required to have desirable surface integrity on the tooth flank. European transmission manufacturers are increasingly using a sequence of continuous form grinding and subsequent honing (internal) for high precision automotive gears for cars. Japanese automotive manufacturers are concentrating on improving the material and heat treatment controls following a sequence of shaving and heat treatment without any hard finishing operations.

## QUALITY MEASUREMENTS IN GEAR MANUFACTURING

During gear cutting and finishing, some errors of the gear teeth are closely monitored to achieve the desired quality standard of the finished gears, Fig. 4.83.

1. **Tooth thickness error** - is the difference of tooth thickness between all the teeth at pitch circle diameter.
2. a) **Individual pitch error** - is the difference between the actual pitch on its pitch circle to an adjacent tooth and the correct value.
  - b) **Adjacent Pitch error** - is the difference between the two adjacent pitch as on the pitch circle.
  - c) **Accumulated pitch error** - is the difference between the sum of actual pitches between any two teeth on the pitch circle and the correct value.
3. **Total profile error** - is the sum of errors both in positive and in negative sides within the region of tooth profile measurement measured vertically to a correct involute as a basis, which passes through the intersection of an actual tooth profile and the pitch circle.
4. **Total tooth lead error** - is the difference between a theoretical curve of tooth trace and that of an actual tooth trace corresponding to the necessary region of tooth profile measurement on the pitch cylinder.
5. **Runout** - is the maximum variation of positions in radial direction of a contacting piece, e.g. a ball or pin, which has been made to contact with both tooth surfaces of the space close to the pitch circle.

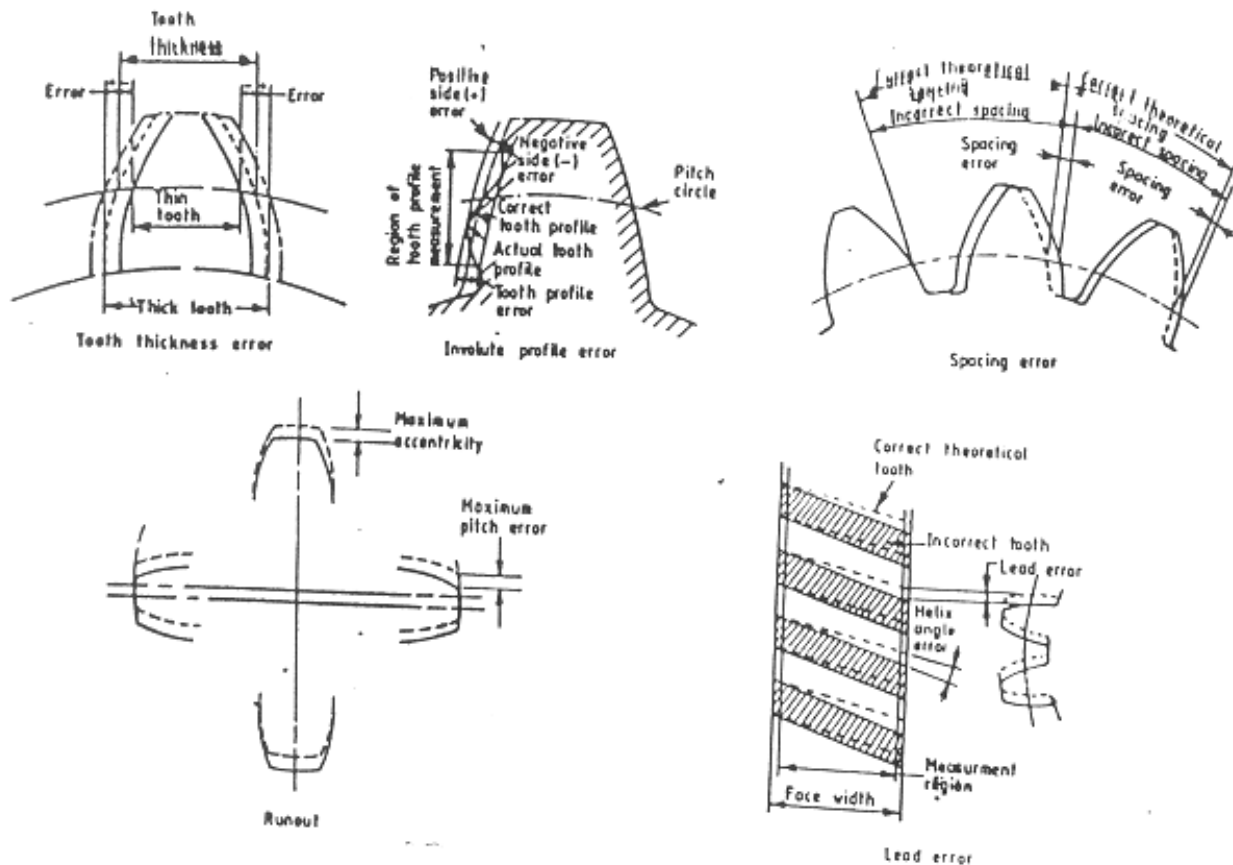

Fig. 4.83 Typical Gear Element Errors

6. **Backlash** - is the play on the reference pitch circle of a pair of gears engaging with each other. The magnitude of backlash for the different gear accuracy grade is established by standards.
7. **Transmission error** - of a gear pair is the 'deviation of the position of the driven gear, for a given angular position of the driving gear, from the position that the driven gear would occupy if the gears were geometrically perfect'.

Each gear error causes certain performance deficiency of gear pair in mesh.

- **Tooth thickness error** - causes excess or reduced backlash between the mating gears. Reduced backlash causes binding. Excess backlash may cause noise (on reversal) and if excessive, loss of tooth strength.
- **Accumulated pitch error and runout** result in gear noise and non-uniform motion transmission.
- **Profile error** causes disruption in uniform conjugate tooth action and uneven loading. It results in non-uniform motion transmission due to momentary disturbances of the rotational velocity, and also causes noise.
- **Lead error** causes inadequate face width contact between the mating gears. It creates again uneven loading, localised bearings and wear. It results in non-uniform motion transmission and noise.
- **Transmission error** causes noise and vibration.

Many standards, e.g. AGMA, DIN, JIS, BSI, cover gear error tolerances. Quality assurance of gears requires various types of measuring equipment during the manufacturing processes:

#### Elemental Checking :

**Tooth thickness:** Different instruments, such as tooth caliper, addendum comparator, measure the tooth thickness depending on the tolerance limits. Vernier gear caliper, Fig. 4.84, measures the chordal thickness at the nominal pitch circle.

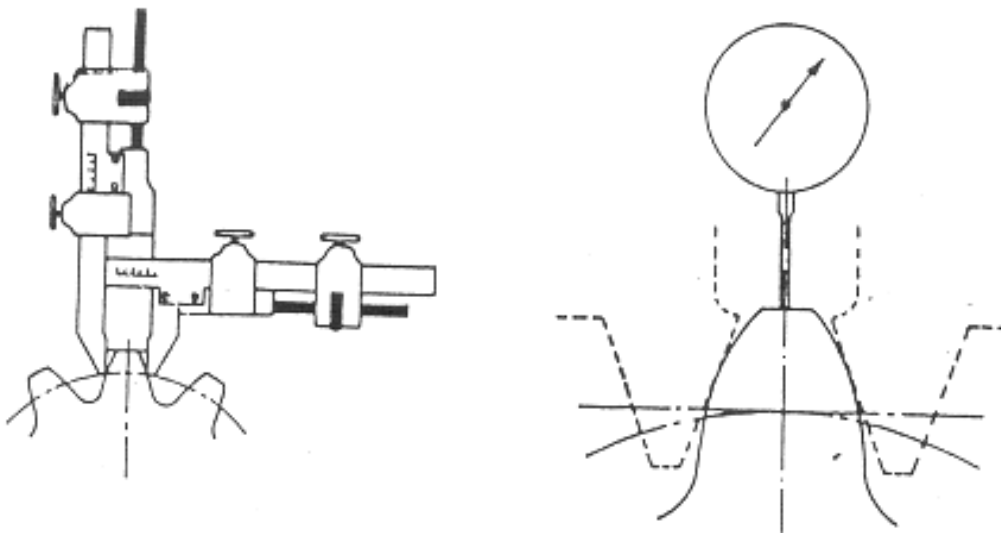

Fig. 4.84 Chordal Thickness Measurement and Addendum Measurement Methods

**Addendum Measurement:** Addendum comparator, Fig 4.84, measures tooth thickness by comparing the gear addendum with that of a basic rack. The comparator jaws have the same angle of the tooth form of the gear to be checked. The comparator jaws are set to proper width with the help of a master corresponding to a rack tooth of proper module. The indicator reads zero on this master. Variation in the indicator reading (+or-) implies the difference in the thickness of the gear being measured with theoretical value. Corrections for taper and dimensional deviations of outside diameter of the gear blank are made as the outside diameter is used as reference point.

**Span Measurement:** A tooth vernier caliper or plate micrometer measures the distance over two or more teeth along a line tangent to the base cylinder, Fig. 4.85. The measurement directly relates to the thickness of a single tooth (or the backlash contributed by the gear to the pair).

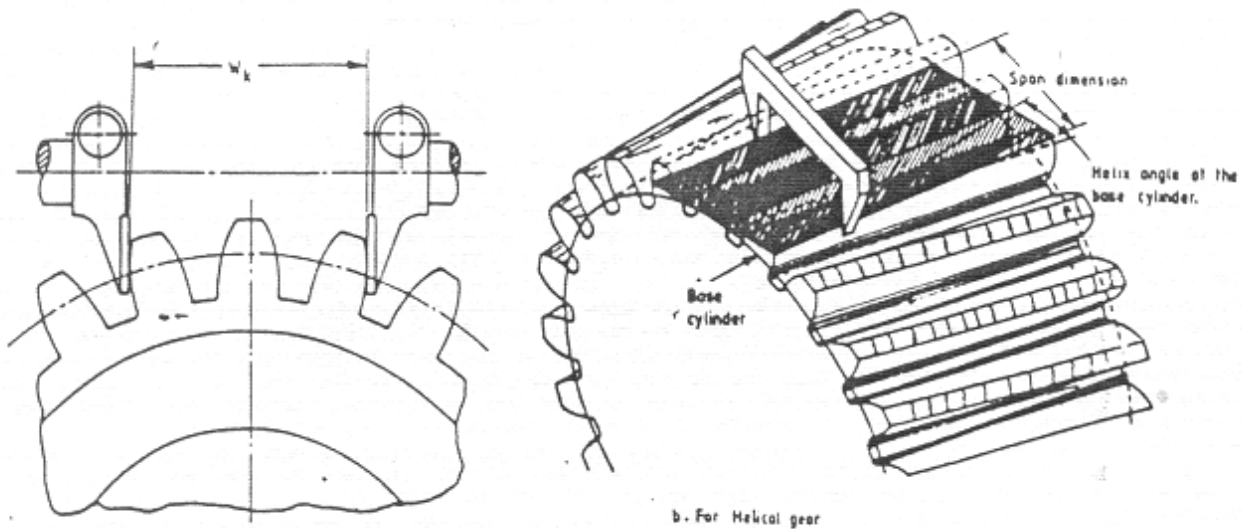

Fig. 4. 85 Span Measurement and principle

Span measurement process suits for spur and helical gears of even or odd number of teeth. It is possible to measure the gears while on gear cutting machine (often while the machine is running). The differences in measurements around the gear are readily noticeable indicating the need of repair of the machine. A small 25 mm range micrometer can handle gears of quite large pitch circle diameter. Dial calipers with at least one plane anvil are suitable for helical gear measurement, while a cylinder-and-sphere anvil dial caliper is acceptable for spur gears only. For a narrow face width gear with high helix angle, the process is not recommended as the spanning of a sufficient number of teeth becomes difficult. For modified profile, the measurements will be erroneous. Runout or size variation of outside diameter does not affect the measurement. However, base pitch errors influence the readings.

**Measurement over pins (balls):** The overpin (or ball) size of the pitch circle diameter of a gear controls the centre distance and backlash of the gear pair. Measurement is easily done for a spur gear with help of a micrometer. The overpin size for helical gears having an even number of teeth is measured by keeping two pins of specified size diametrically opposite in the tooth space, Fig. 4.86. For helical gears having odd number of teeth, the measurement is somewhat difficult. Little improvement may be there in measuring over two properly placed

balls. The diameter of the measuring pins (balls) is such that it makes contact with the tooth flanks in the vicinity of pitch circle where the involute error is minimum. Variation or runout of outside diameter does not influence on the accuracy but errors in spacing and profile does affect the measurement. The method is almost universally used to check and control the size of gears at all stages of gear processing - cutting, soft finishing, hardening as well as hard finishing.

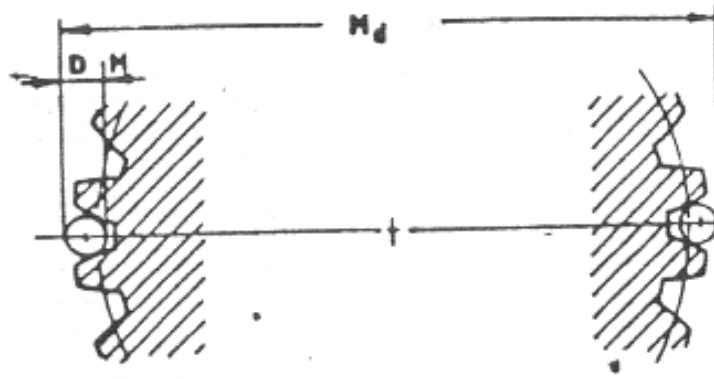

Fig. 4.86 Over-pin Measurement of Gear Pitch Circle Diameter

**Profile:** Measurement of an involute profile is based on its geometric property (A line normal to an involute curve is a tangent to the base circle). An involute is thus the co-ordinates of heights to a tooth and angles from the base circle, Fig. 4.87. A base circle disc and straight edge are used to measure the involute profile. Gear is mounted with a base circle disc coaxially. A small pressure applied between the straight edge and the disc moves them simultaneously. A point on the straight edge and so the stylus that is mounted directly above the straight edge, describes the involute curve. Imperfections of the involute profile are transferred through the corresponding deflections of the stylus and are recorded on the graphs so that the error can be quantitatively measured.

**Lead:** During lead checking, the stylus traverses the total width of the tooth. The deflections caused by the variation in the lead over the tooth width are recorded, Fig. 4.88.

**Pitch variation:** Pitch variations are measured in two ways:

1. **Precision indexing:** The gear is indexed accurately (mechanically, electronically or optically). A single probe measures the actual position of each tooth relative to the theoretically correct position of each tooth. Adjacent and accumulated pitch error is directly measured.

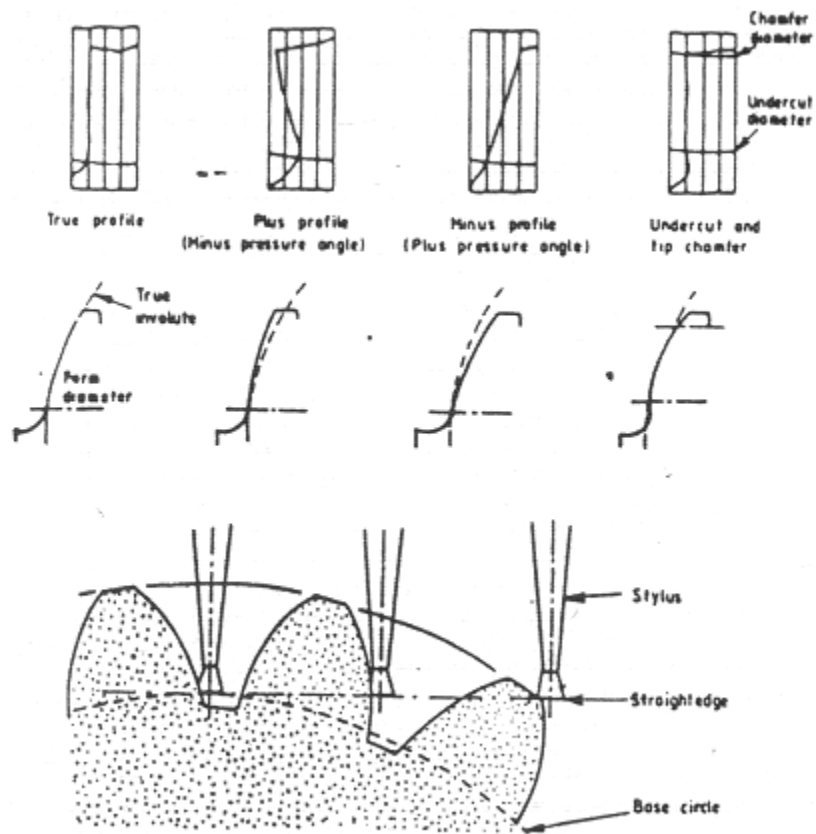

Fig. 4.87 Principle of Involute Profile Measurement

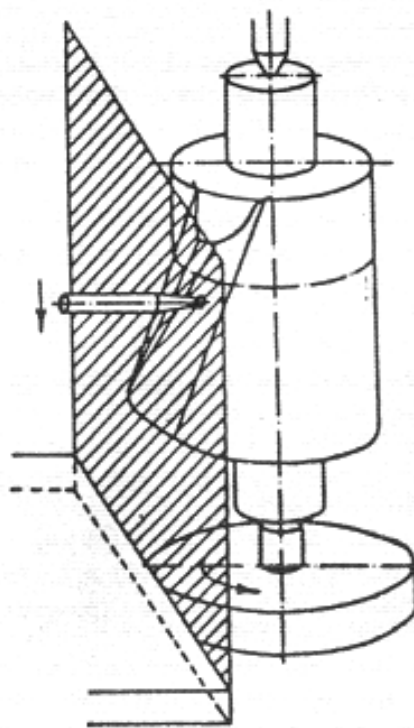

Fig. 4.88 Lead Measurement Principle



2. **Tooth space comparison:** A two probe system records the distance from a point on tooth number 1 to the corresponding point on the tooth number 2. The two probes continue checking all around the gear one after another. The system only compares the tooth gaps. Each measurement is taken from a different datum. For direct contact type measuring probes, surface finish of tooth flanks affects the result. A proximity measuring probe averages the flank irregularity.

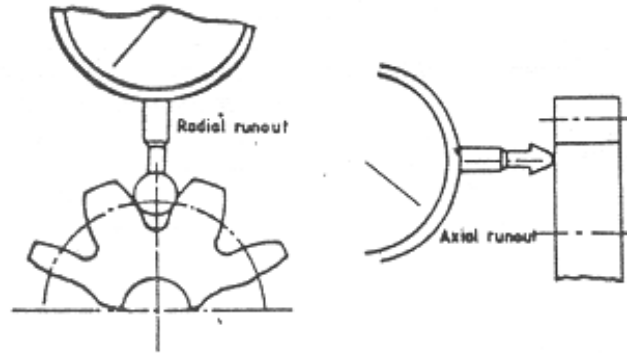

Fig. 4.89 Gear Runout Checking Principle

**Runout:** A ball or roller of specified size placed in each tooth gap, Fig. 4.89 measures the radial runout on the pitch circle diameter..

Presently, a single machine checks almost all the parameters in same setup. The machines are conventional mechanical type or fully computerised numerically controlled type with different level of automation.

### Conventional Gear Measuring Machine

A conventional lead and profile tester, Fig. 4.90 uses a base circle disc for measuring profile error. A sine bar is built into measuring system for setting the helix angle for measuring lead error. The gear under test and the base circle disc are directly mounted on the same axis. When the generating slide moves, the base circle disc rolls along the straight edge without slip. During this motion, the spring loaded stylus mounted on the pickup slide remains in contact with the tooth flank of the gear. The deviation from the true involute causes the equivalent deflection of the stylus. The deflections are converted into electronic signals and transmitted to a recorder or a plotter. The diameter of the base circle disc should be equal to the base circle diameter of the gear under test. A separate base circle disc is required for different diameter of gear. As an improvement, with an additional mechanical system for motorized adjustment of the base circle setting value, one base circle disc can be used for gears within a range of base circle diameters.

For measuring the lead error for helical gears, the helix guide on the vertical slide is set to the base helix angle. As the vertical slide together with the helix guide is moved up and down, the sliding block moves the control slide in the direction of arrow. The motion of the stylus relative to the tooth flank therefore coincides with the theoretically correct helix. Any deviation of the tooth trace from this helix produces a deflection of the stylus that is converted again to an electronic signal and transmitted to the recorder. The same machine also checks the pitch error (adjacent, single and accumulated) with a special measuring head mounted on an independent slide on the base. Even surface roughness of the gear profile may also be measured.

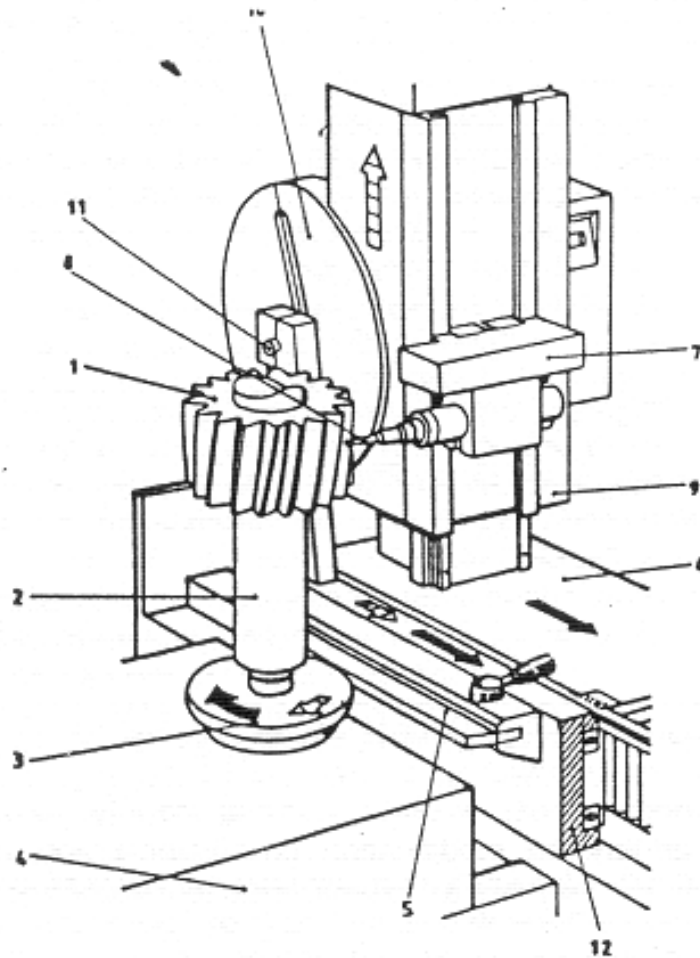
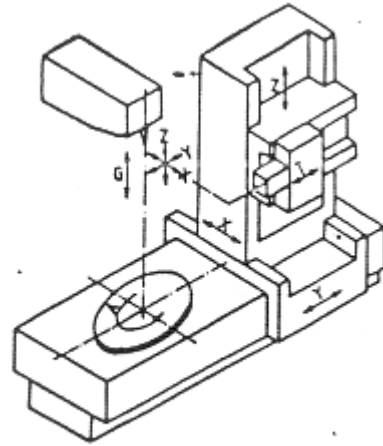

Fig. 4.90 A Conventional Lead and Profile Measuring Machine

### CNC Gear Measuring Centre

CNC gear measuring centre checks all the important gear tooth errors and modifications automatically with better accuracy and in very short time. It does not need any base circle disc. The stylus moves in a tooth space, and the automatic measuring starts. Generally, right and left flanks of 4 teeth at 90 degree apart are measured. A single probe performs all the measurements with movements produced by individual table and slide on several axes, Fig. 4.91 through a CNC continuous path control system. The CNC control determines the required relative feed rate for the measuring links and the speed for the rotary workpiece drive to suit the individual tests based on the gear data input. The control system calculates the theoretical base circle radius. The deviations from the nominal involute form and the nominal helix are registered and transmitted to the computer. For pitch measurement, the

rotary and linear measuring systems register and transmit to the computer the exact angular position of each tooth flank. The electronically controlled tracer stylus advances into and withdraws from the tooth gaps on completion of the measured data pickup, while the workpiece rotates continuously. The desired information about the errors appears as traces and digital form on screen and may be plotted and printed automatically. Automation to any desired extent is possible.



X,Y,Z,T - Linear movements of slides  
G - Tail stock movement  
A - Table Rotation

**Fig. 4.91 CNC Gear Measuring Centre**

With 6 major gear parameters (number of teeth, normal module, normal pressure angle, helix angle, face width, addendum modification co-efficient) entered, typical results obtained in fully automatic measuring are as extensive as follows:

- ✓ radial runout (curve)
- ✓ total runout
- ✓ runout variation
- ✓ dimension over 2 pins (minimum and maximum value)
- ✓ cumulative pitch error (curve)
- ✓ total cumulative pitch error
- ✓ adjacent pitch error (curve)
- ✓ pitch variations
- ✓ maximum tooth to tooth pitch error
- ✓ tooth trace (curve)
- ✓ total trace error
- ✓ trace alignment error in tooth width
- ✓ trace form error
- ✓ actual helix angle
- ✓ involute profile (curve)
- ✓ involute profile alignment error
- ✓ total involute profile error
- ✓ involute profile form error
- ✓ base diameter error

Software packages are also available for :

- display or print of 'accept or reject' by analysing the measured data relative to a tolerance band
- display or print of quality class AGMA, DIN, JIS standard by evaluation of measured data.
- Topographical representation of tooth flanks
- Comparison of measuring results of different manufacturing stages (e.g. soft/hard)
- Tooth bearing pattern simulation
- Automatic check of all individual gears on a cluster component.
- Various analysis from stored data for many gears.
- Checking of hobs, shaping cutters, shaving cutters and many special workpieces.

Computerised gear testing provides certain clear advantages over the mechanical ones :

1. speeds up gear checking
2. gives a numerical measurement of gear errors instead of subjective operator interpretation
3. indicates direction of errors with respect to reference surfaces
4. facilitates statistical analysis for a longer period that helps in new engineering.

The measuring machine for the shop floor inspection is to be fast and rugged. A sophisticated gear measuring machine may regularly check and analyse the gears in production for improvement of quality standard.

### **Composite Action Checking**

Unlike elemental checking, composite action checking simulates the actual working condition without the dynamic loading. Composite action checking method involves rolling of two gears together. Methods used are double flank testing and single flank testing, Fig. 4.92

**Double Flank Rolling Tester:** The double flank rolling tester rolls the gear under test with a mating gear (generally, a master gear) while tightly in mesh under spring load and shows error as variation in centre distance, Fig. 4.93. The double flank tester effectively measures gear size, backlash, eccentricity (runout), damages on active profile, tooth-to-tooth and total composite error. Double flank rolling testers may be used as production equipment for inspection of gears both before and after heat treatment. However, with improved reliability of gear manufacturing processes, the use of double flank roller testing is diminishing.

**Single Flank Rolling Tester:** Single flank rolling tester makes the gear roll under test at the correct centre distance with a master gear (or mating gear) and shows errors as variation in constant angular velocity using optical encoder. Data from the encoder after due processing shows the smoothness of the rotational motion of the mating gears (transmission errors), Fig. 4.94. Gratings of high accuracy and resolutions are used to compare the motions of the two

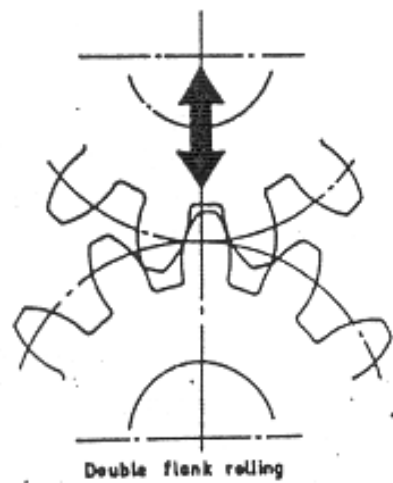
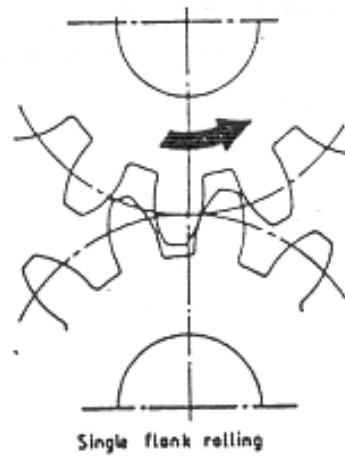

**Fig. 4.92. Single Flank and Double Flank Gear Tester**

gears. Each grating gives a train of pulse having the frequency that is a measure of the angular movement of the two shafts. With one train of pulses as the reference signal, the phase difference is measured electronically and recorded as an analog wave form on a strip chart. The analog data of one revolution of a gear against a perfect master gives values for -

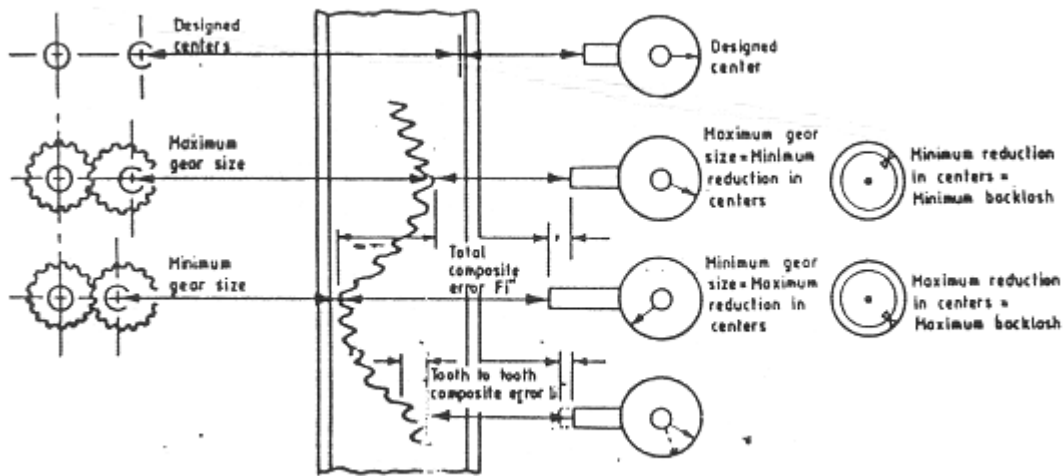

Fig. 4.93 Principle of Double Flank Testing

- 1) total transmission error
- 2) tooth-to-tooth transmission error
- 3) accumulated pitch variation
- 4) pitch variations
- 5) profile error

While total transmission error is related to accuracy, the tooth-to-tooth transmission error is considered critical for noise and vibration. So single flank tester is considered effective in monitoring the quality standards of the gear under test.

A gear with runout does not have accumulated pitch variation, while a gear with accumulated pitch variation does not necessarily have runout. This situation arises when a gear is cut with runout and then shaved where the cutter is not connected to the gear by a drive train. The cutter removes an equal amount of material from each flank of every tooth. All gaps are now machined to the same radius from the centre of rotation and are displaced from true angular position by varying small amounts. This shaved gear has a very small amount of individual pitch variations but has a large accumulated pitch variation. Single flank tester can check the accumulated pitch error, which is generally introduced during shaving. Double flank tester will fail to detect accumulated pitch error. A gear accepted through double flank tester, may become the reason of a noisy transmission.

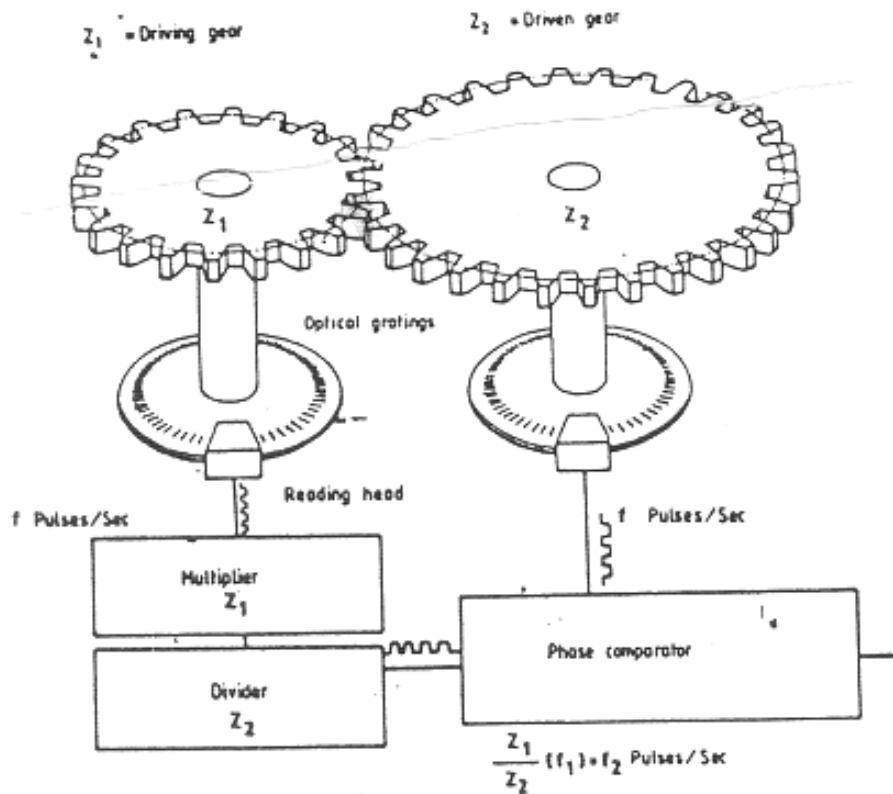

Fig. 4.94 Principle of Single Flank Testing

### Gear Selecting Machine

Many automatic gear selecting machines based on double flank testing method are in commercial use. The one, Fig. 4.95 developed by Isuzu Motors and Osaka Seimitsu of Japan is reported to be very much effective in detecting the nicks. As against two conventional master gears, the machine uses two specially designed master gears. One master gear with hollow lead, larger pressure angle and width than the gear to be tested, inspects nicks on both acute and obtuse angle sides. The second master gear with true involute and lead curve but narrow in width than the gear to be tested inspects the size, runout, tooth-to tooth composite error. A burnishing station with 3 gears is used in line prior to selecting station to remove the burrs that can not be removed in washing. The burnishing gears are different to each other. The first one is the pressing gear with its pressure angle longer by 50 microns and true lead. The second one is the driving gear with its helix angle less by 2 to 3 degree and the true pressure angle. The gear to be tested is located in the centre of the three gears. The gears pass through a washing machine, a burnishing unit. At the selecting station, the gears are sorted and directed in different chutes (as OK size 1, OK size 2, rejected for nicks, runout and size). Mating gears for a set can be more reliably selected before assembly through this method.

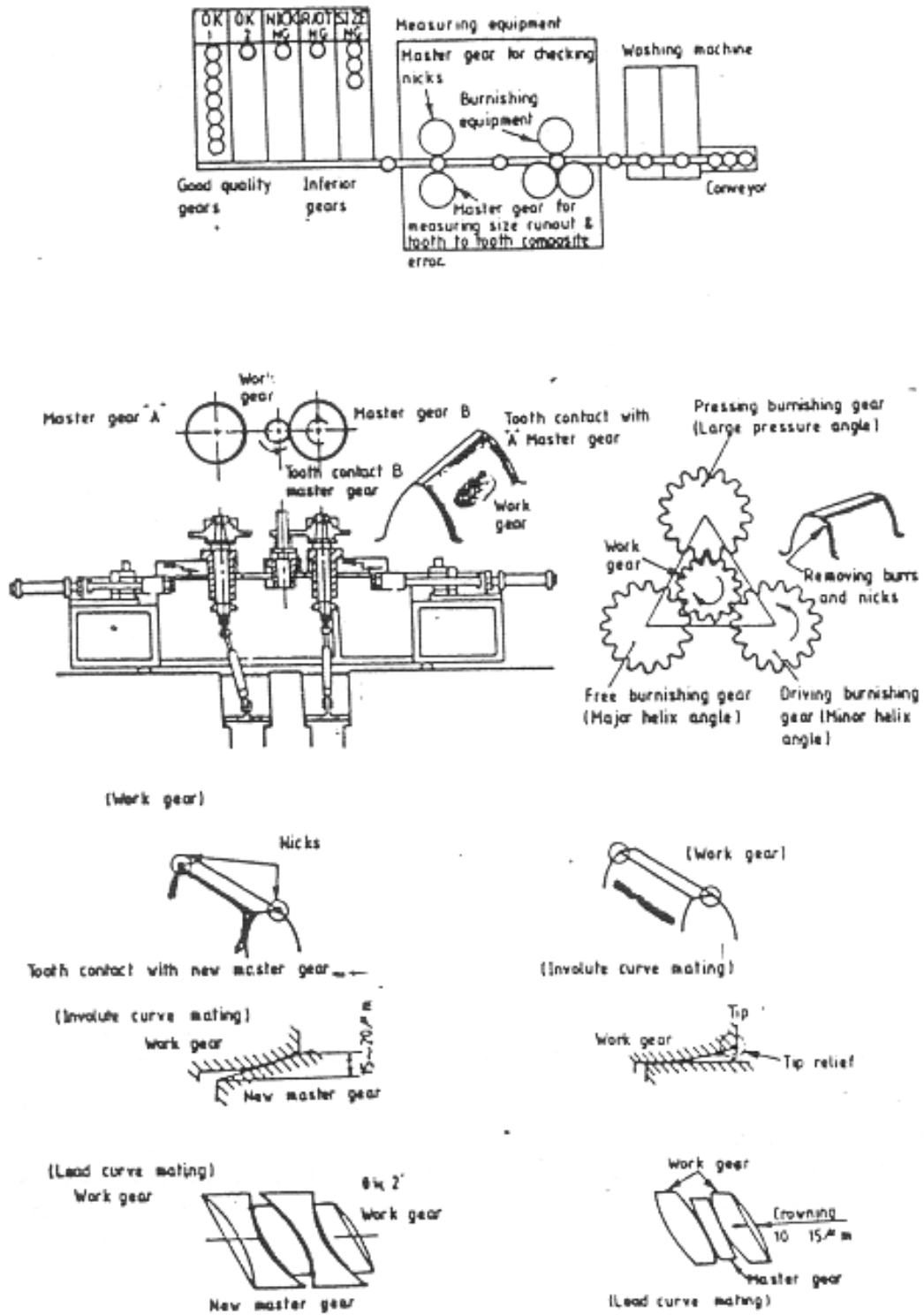

Fig. 4.95 An Improved Version of Gear Selecting Machine



## Final Objective Testing

The transmission gears are checked and sorted for their expected performance in assembly by some objective testing.

1. **Bearing Pattern on Meshing Gears:** Bearing patterns are observed on active profile of gears after a short run under slight load. A fair assessment of the expected quality level when assembled can be made. On a gear speeder, the gears in mesh are painted with red or yellow powder and are run under load for a short time.

2. **Noise Testing:** Gear noise testing is done by revolving mating gears. A motor with infinitely variable speed is used to run the gear at desired speed. A generator operated brake applies the braking force. A built-in tachogenerator maintains constant speed even after braking. Earlier, the acceptable noise level of gears was decided by experienced operators on a conventional gear speeder and the machine was kept in sound proof room. Presently, sophisticated noise testing equipment with measurable decibel features are used to assess and accept the gears as per established noise standard. Gear acceptance testing based on tangential acceleration measurement is claimed to be very much reliable and fast with help of a simple easy-to-read scale. Even a sound insulated room is not required.

3. **Final Assembly Testing :** Transmission assembly is tested on a test rig for checking the different criteria of performance (e.g. noise at different speeds for acceleration and deceleration, shiftability ease) under simulated load condition for a short time. Dynamometer type test rigs are used for development purposes.

## FINALLY

It can be very rightly concluded that gear manufacturing is no more a black art. Recent advances in gear manufacturing and measuring technique with advance control have resulted in new level of flexibility for attaining a more uniform, predictable and repeatable productivity and precision characteristics.

Besides the gear manufacturing technology, the whole production system is undergoing transformation. Today the lay-outs of machines are preferably becoming cellular with or without automated component handling. Component handling is critical in gear manufacturing system, as any damage during handling upsets the microns achieved on profile. Automation can go from machine loading/unloading to totally unattended level depending on capital investment possible. Gear manufacturing processes are more shop oriented than other machining processes. Operations in gear manufacturing are also more inter-related and independent. An organisation structure providing emphasis on cross functional management integration will be more beneficial than the conventional functional organisation structure that is generally prevailing in gear manufacturing plants.