

INDEX

Index.....	3
1. Introduction.....	5
1-a. General Concepts.....	5
1-b. Operation Principles.....	5
1-c. Operating Requirements.....	5
1-d. General Features.....	5
1-e. Grain extractor identification.....	6
1-f. Guarantee Terms.....	6
1-g. Safety.....	7
2. List of Main Components.....	11
3. Receiving the machine.....	15
4. Position changes.....	16
4-a. Change from Transport Position to Operating Position.....	16
5. Set up for extraction.....	18
5-a. General Comments on the Storage in Grain bags.....	18
5-b. Recommendations to Make Extraction Easier.....	18
5-c. Previous Controls on the Machine.....	19
5-d. Machine Layout.....	19
5-e. Grain bag Preparation.....	20
5-f. Final Adjustments on the Machine.....	20
6. Extraction Process.....	22
6-a. Operation Start-up.....	22
6-b. Operation Parameters.....	23
6-c. Protection against Overloads.....	24
6-d. Interruptions during Extraction.....	24
6-e. Extraction at the End of the Bag.....	25
6-f. Unwinding the Bag.....	25
7. Preparation of the Machine for Transport.....	26
8. Maintenance Program.....	28
8-a. General Maintenance.....	28
8-b. Lubrication.....	29
9. Spare Parts List.....	31
9-a. Information for Obtaining Spare Parts.....	31
10. Parts Subject To Wear.....	51
11 User's Notes.	53

1. INTRODUCTION

The present user’s manual describes the functions and components of the *AKRON® grain extractor model E 180 TH*. It gives detailed safety instructions and provides recommendations for its operation, also offering a general maintenance guide for the machine.

1-a. General Concepts

The *AKRON® E 180 TH grain extractor* has been designed to extract in very short times large volumes of cereal stored in plastic grain bags. The grain extracted, dry and unbroken, is lifted high enough to load any grain transport vehicle.

1-b. Operation Principles

The main functions of the machine are described below, as well as the elements used to perform each one of them.

Function	Related component or system
Fixing and winding up the grain bag	Roll driven by hydraulic motor
Grain transport	Auger driven by tractor PTO
Longitudinal cut (slash) on the grain bag during motion	Cutting blade
Motion of the tractor-extractor assembly	Automatic movement achieved by winding up the grain bag on the roll
Motion speed adjustment	Flow control valve operating on the hydraulic motor which drives the roll

1-c. Operating Requirements

Requiring as little human effort as possible is one of the most important premises for the machine’s design, as well as attaining the best possible comfort level for the operator.

A relatively low power tractor, around 80 HP, is required for this machine’s operation. Of this vehicle, both its 540 rpm power take-off (PTO) and its oleo-hydraulic system are used, the former for driving the grain augers and the latter mainly for winding up the grain bag. This way, the tractor’s traction system remains free, which avoids an excessive wear of the clutch.

Special care must be taken not to use a tractor with a power rating far greater than the recommended figure, and the front wheels should be plain, not studded. Pulling a heavier tractor would cause excessive efforts on the extractor’s structure and components.

1-d. General Features

- Operating capacity.....180 ton/hour
- Operation.....Tractor with 80 HP available in its PTO
- Tube / Lifting auger.....Ø 400 mm
- Height adjustment.....Enough to absorb differences in the hitch
- Transport position.....Requires configuration changes

1-e. Grain extractor identification

When ordering parts or requesting technical assistance or information, always provide the following details for product identification purposes:

- Model
- Serial Number
- Year of manufacture

This information is engraved on the identification plate, which is located on the machine's chassis as shown on the picture:



Please fill in the following information for your records:

Note: The information, specifications and pictures shown in this manual are based on the information available at the time it was written. Due to the continuing improvements made on the design and manufacture of Akron® products, **Micrón Fresar S.R.L.** reserves the right upon the modification of components and/or specifications given in the present manual without prior notice.

Pictures and diagrams are only illustrative

1-f. Guarantee Terms

Micrón Fresar S.R.L. guarantees the *AKRON® E 180 TH mechanical grain extractor* for a two-year period as from delivery to the customer, regarding machine defects due to its design, to the materials employed, or to its manufacturing or assembly processes.

Any damages or faults caused by improper operation or by lack of maintenance to the machine are excluded from this guarantee. The operation procedures held as appropriate are the ones described within this manual.

Moreover, no responsibility will be taken for defects appearing during the operation of the machine by unqualified operators, or by any person with his abilities altered by the consumption of medication, alcoholic drinks, or any other substance that may affect his normal behaviour and fitness.

The machine will be automatically excluded from these guarantee terms if any of its parts is modified or replaced by a spare part not provided by **Micrón Fresar S.R.L.** If such replacement or modification were urgently necessary, the user should obtain a written permission from **Micrón Fresar S.R.L.** to make such changes without affecting these guarantee terms.

Akron warranty does not cover the cost of travelling time, mileage, labour or hauling.

1-g. Safety

Even though the machine’s operation is extremely simple and safe, it is essential that every operator and supervisor learn thoroughly the contents of this user’s manual. This way, most hazardous situations will be avoided for the operator, for third parties and for any goods placed nearby the operating area.

To achieve this, it is fundamental that all operators and supervisors without exception read and understand clearly this manual. The training should include every detail of the machine’s operation, and should also be backed by written records.

On different parts of the machine you will find stickers with accident prevention symbols, which must be held as part and extension of the instructions detailed on this manual. If any of these stickers gets lost or becomes illegible through wear it is important to contact our company to ask for a replacement.

The same as with the operation of any other machine, what is most important to avoid accidents of any kind is the positive attitude of both operators and supervisors towards safety. This means that, besides observing the manufacturer’s instructions, they should get used to foreseeing and analysing every possible special contingency that could arise during the operation of the machine. Despite the fact that it is virtually impossible to foresee all the possible situations, this habit contributes to the prevention of several hazardous situations.

To give an example of this, the horizontal augers and all the transmission components used to drive them are furnished with protective covers to avoid accidents. This is the solution given to a potential risk foreseen by the manufacturer. However, the effectiveness of these covers entirely depends on their being in the correct place before the machine is started, just as it is indicated in the warnings given within this manual. Besides, apart from other instructions, we must insist on the fact that no person should climb onto the machine when the extraction operation is about to start.

Micrón Fresar S.R.L. recommends the use of the following personal protective equipment in order to avoid possible physical damage:

<div style="text-align: center;">Personal protective equipment</div> <div style="text-align: left;">Situation</div>			
Tractor driver	✓	✓	
Extractor operator	✓	✓	✓

Risk Analysis

The risk situations that typically arise during the operation of this machine are detailed below. Recommendations are made that are of vital importance for the safety of the machine operators, of other workers nearby, and the machine itself.

The pictograms used are taken from IRAM standard 8075 "Tractors, agricultural and forestry and green space maintenance machinery - Safety signs and hazard pictograms - General principles and features". For more details, their location on the machine is shown in the following picture. sobre la máquina.



DRIVESHAFT
CODE: 114132



READ THE
OPERATOR'S
MANUAL
CODE:114112



STOP THE
MOTOR
CODE: 114122



HAND TRAPPING
CODE: 114152



HAND SHEARING
CODE:114162



MAXIMUM
SPEED
CODE: 114138



WARNING
CODE: 016135



HAND
SQUASHING
CODE: 114178

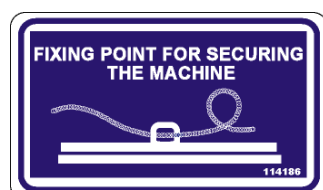

TYING FOR
TRANSPORT
CODE: 114186



MAXIMUM 540
RPM
CODE: 014128



DO NOT TRAVEL ON THE MACHINE
CODE: 114181



CRUSHING OF FEET
CODE: 182118



KEEP AWAY FROM THE MACHINE
CODE: 114200



FINGER AND HAND INJURES
CODE: 182130



CRUSH HAZARD
CODE: 182140



SAFETY DECALS
CODE: NOTICE



BLADE
CODE: 180108



CLOCKWISE ROLL ROTATION
CODE: 080111
COUNTER
CLOCKWISE ROLL ROTATION
CODE: 080110



TRACTOR'S SIDE
CODE: 065823
MACHINE'S SIDE
CODE: 065824

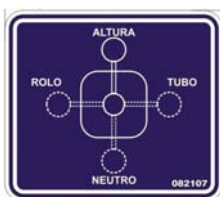

SWITCH VALVE.
CODE: 182107

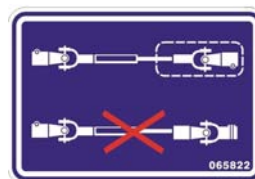

CARDAN COUPLING POSITION
CODE: 065822

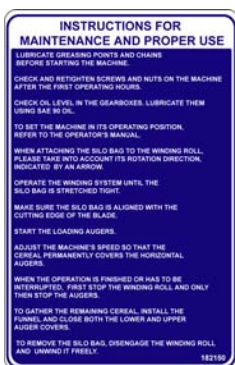

MAINTENANCE CODE:
182150



RISK OF ELECTROCUTION
CODE: 180105

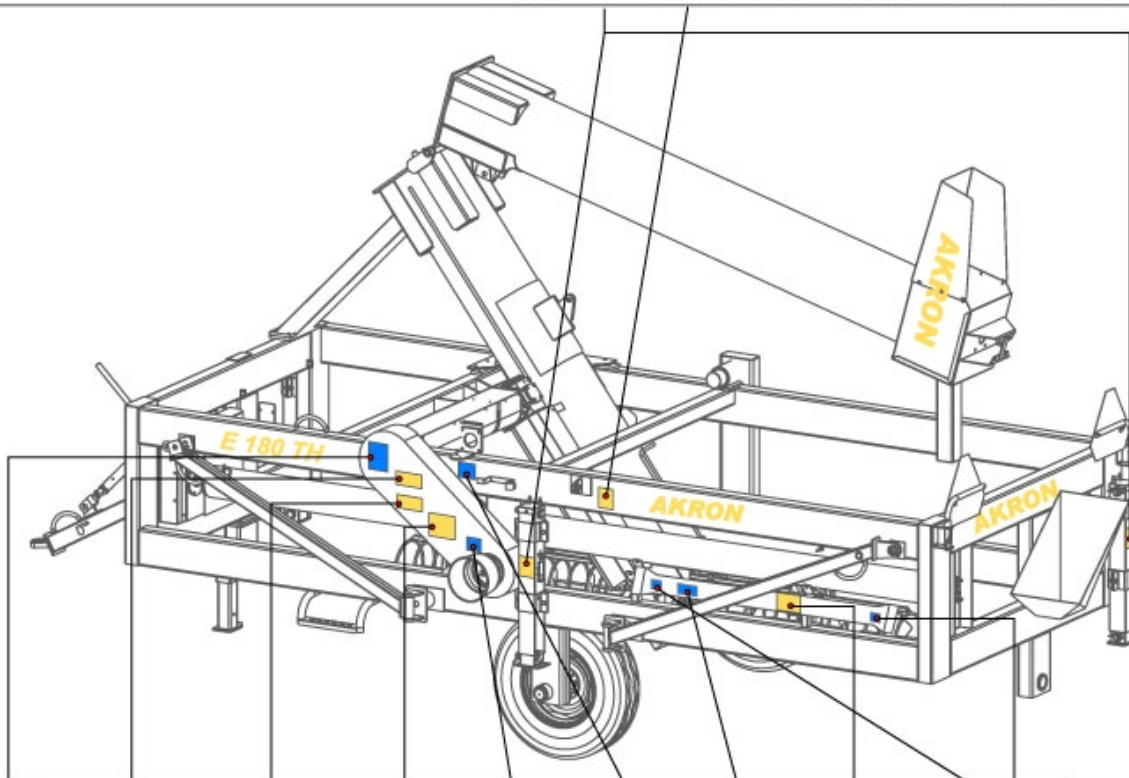
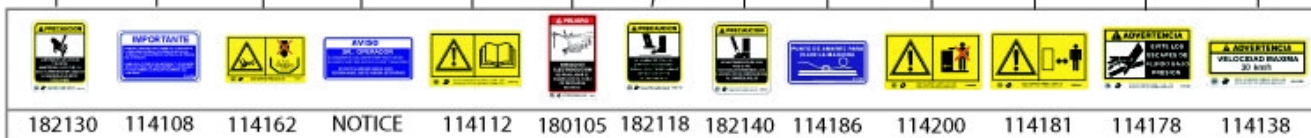
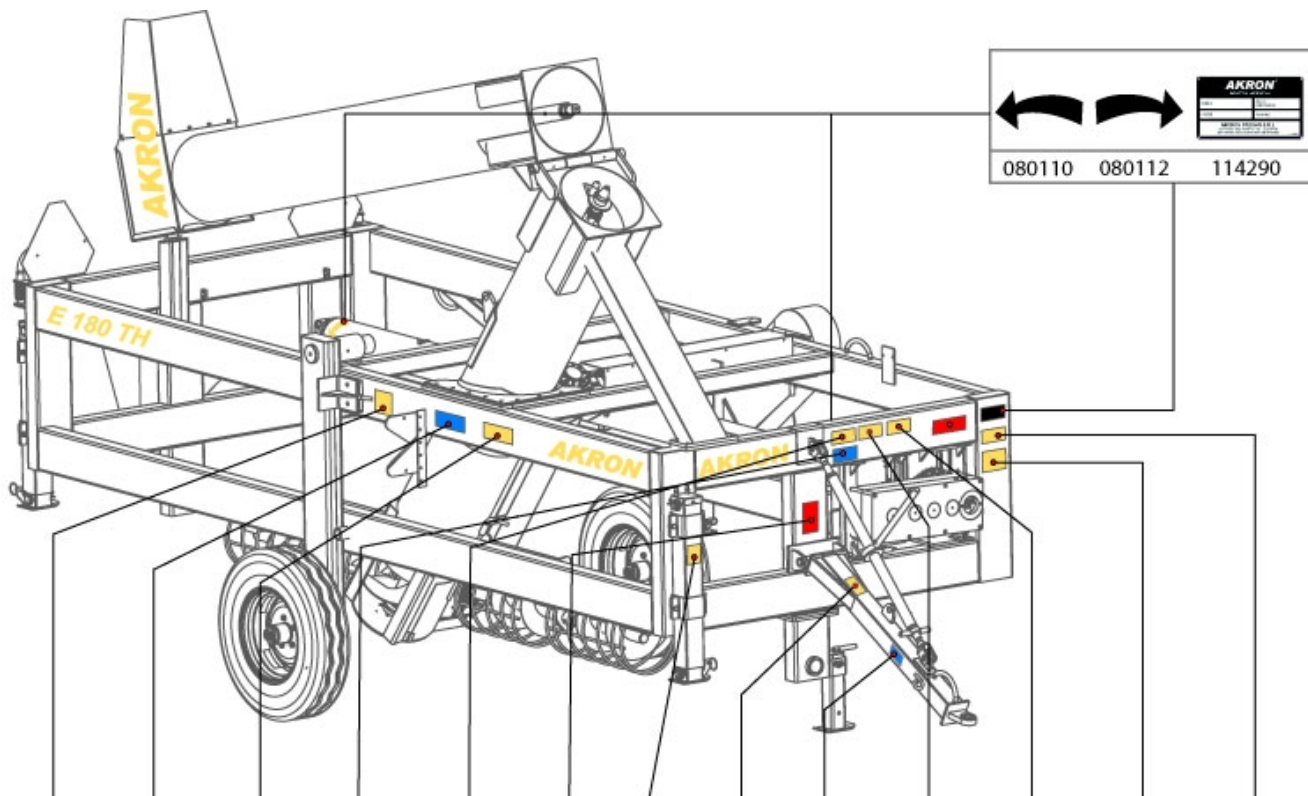

2. LIST OF MAIN COMPONENTS

Ref.	Description	Summary of functions
1	Wheel	The wheels, which are indicated as right and left wheels during transport, are removed and relocated on both ends for the operating position.
2	Roll	As the extraction is performed, the bag is wound on it.
3	Step	The operator can climb on it in order to check the operation of the machine.
4	Flow control valve	During extraction, it regulates the grain bag winding speed. This rotation speed must be co-ordinated with the grain extraction speed.
5	Drawbar turnbuckle	It allows the machine to be towed by a pick-up or tractor when it is in transport position. When the machine is in its operating position, it allows the towed tractor to be linked to the extractor.
6	Double draw-bar	During the extraction process, this element links the machine to the towing tractor. It is foldable, and both halves of it can be linked by means of a pin.
7	Switch valve	Four options can be selected: hydraulic circuit for the retractable supports, for the tube (lifting auger), for the roll and neutral.
8	Safety lights	Two reflecting lights which increase the machine's visibility.
9	Tube / vertical auger	It provides a way for the grain to be lifted and transported to the reception vehicle.

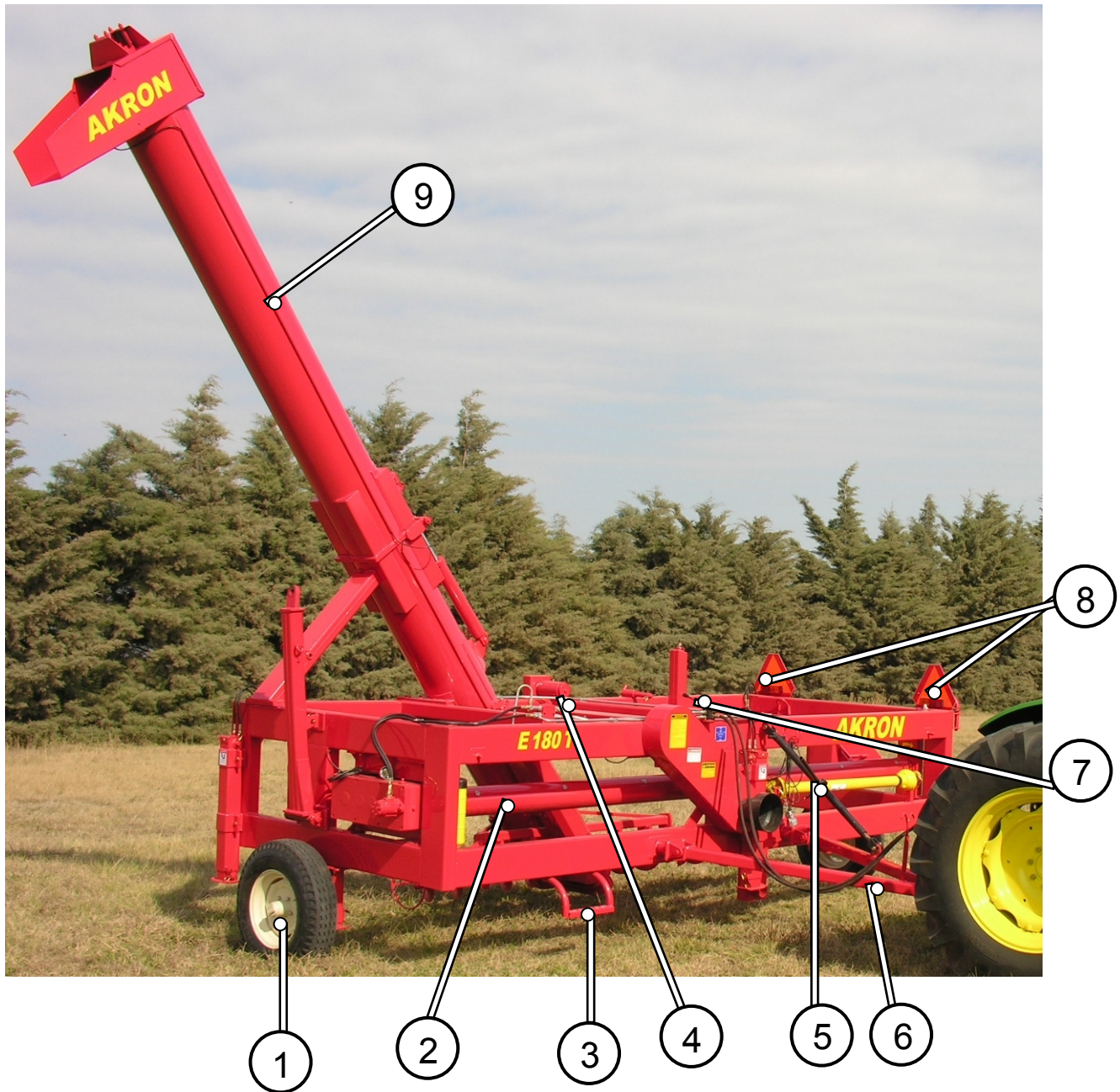

Ref.	Description	Summary of functions
10	Lifting auger lock pin	It fixes the lifting auger to the machine's chassis during the machine's transport. It must be removed before elevating the tube.
11	Retractable supports	They supply three provisional support points during position changes. They are hydraulically operated.
12	Oscillating support	It holds the right wheel in its place during transport. It is retracted while in the operating position to avoid interference with the augers.
13	Auger cover	Both covers generally screen the lower part of the lifting auger during manual extraction, either at the beginning or at the end of the extraction process.
14	Cutting blade	It cuts the grain bag as the tractor-extractor assembly moves forward.
15	Support leg	It acts as the fourth provisional support point which guarantees the machine's static balance while the necessary adjustments are made during position changes.
16	Foldable draw-bar	It links the machine to the towing vehicle. It is necessary only for the machine's transport.

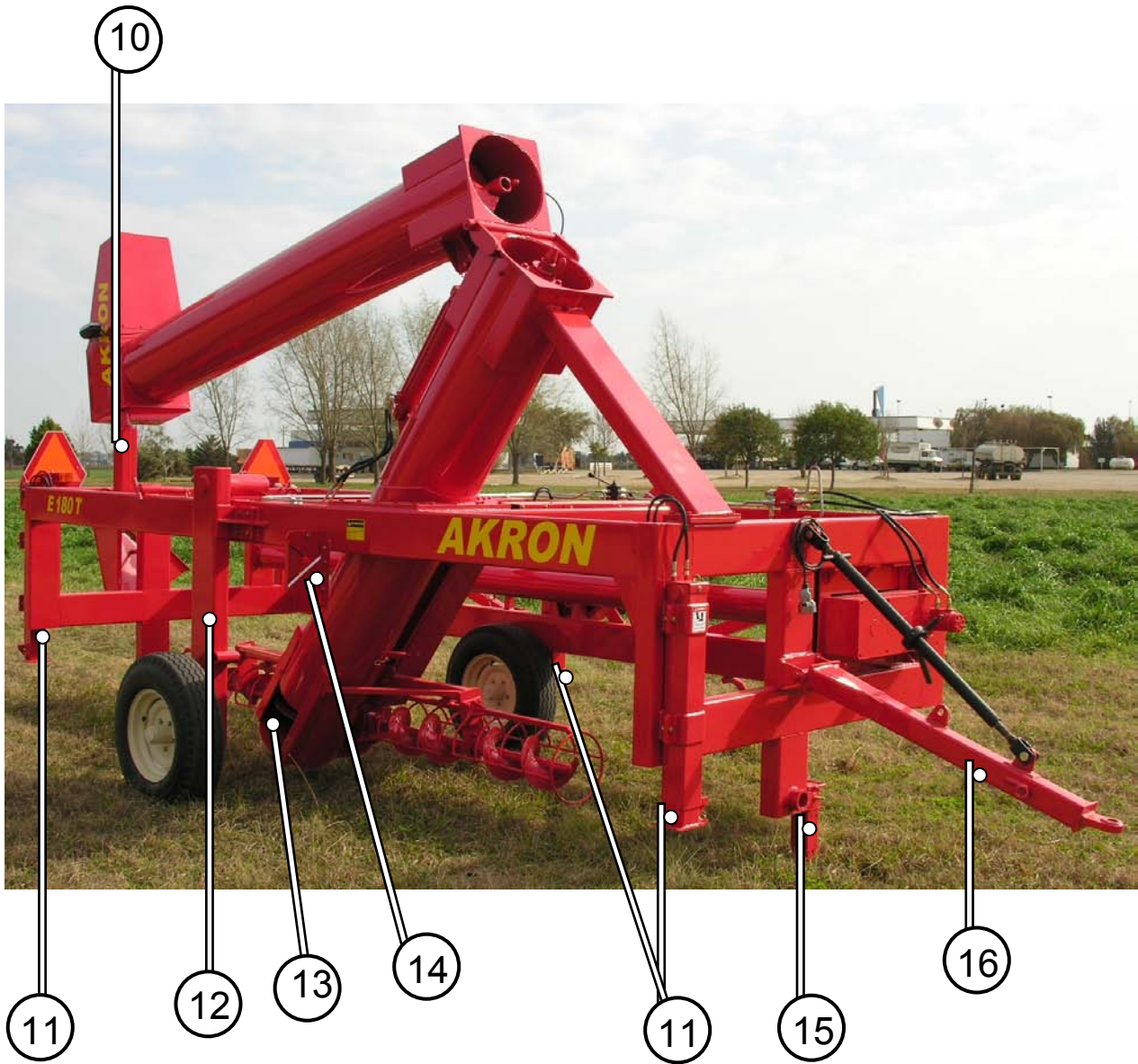

3. RECEIVING THE MACHINE

The grain extractor AKRON® modelo E 180 TH is delivered almost ready for operation. Only a number of verifications related to transport issues must be taken into account upon receiving the machine.

- 1) If the machine is delivered on a truck or other vehicle, special care must be taken to remove all the elements used to fix the machine to the transport vehicle.
- 2) If the machine is delivered in tow, running on its own wheels, the pressure of the wheels must be checked to be at a reasonable level.
- 3) In both cases, the machine's paint and structure must be checked to be free from damages that could have taken place during transport. If that were the case, it would be convenient to assess if the damage could influence the machine's normal operation or if its integrity could be affected in the future.
- 4) All the machine components must be checked to be present and in good operating conditions and all the mechanisms should be operative.
- 5) All the safety guards and protections should be present and in good conditions (e.g., the lifting auger lock pin, the drawbar cover, etc.)

4. POSITION CHANGES

The AKRON E 180 TH mechanical grain extractor can be set in two possible configurations: an operating position and a transport position. The transport position allows the machine to be taken in tow by a pick-up or tractor, complying with the maximum transportation width allowed.

In the following figure, the main features of both positions can be compared. Apart from the draw-bar position and the location of the wheels, the lifting tube can be seen to be retracted.

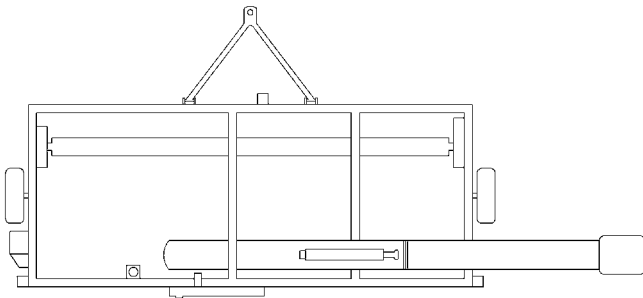

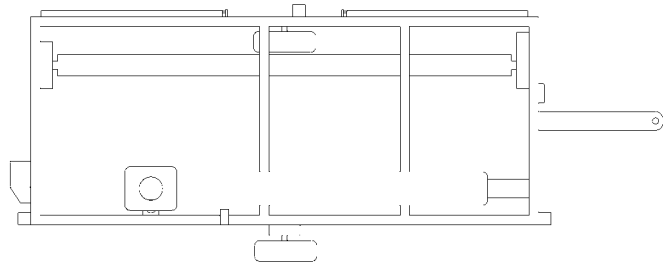

Operating position



Transport position

4-a. Change from Transport Position to Operating Position

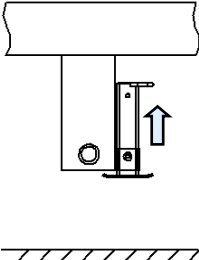
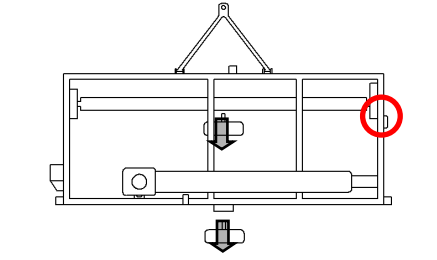
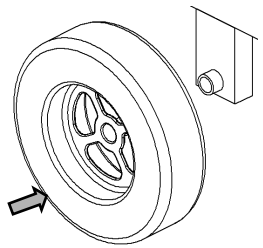
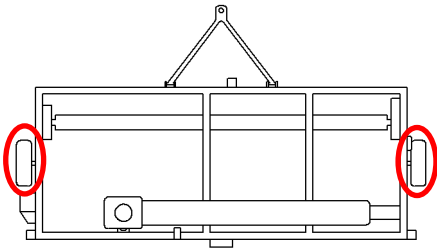
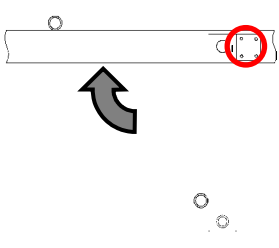
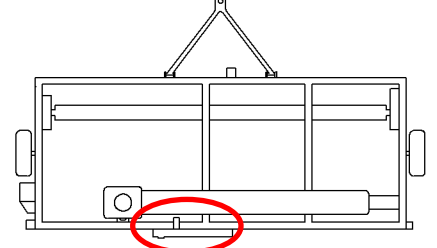
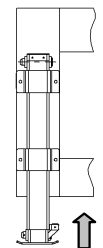
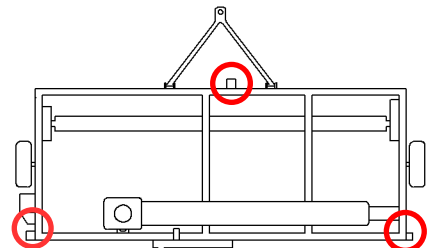
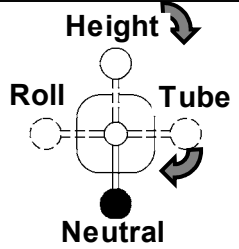
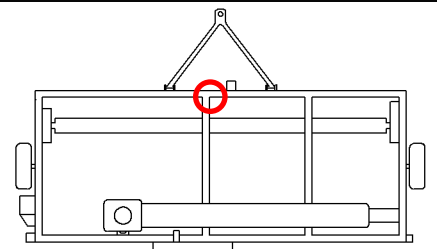
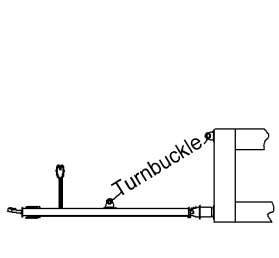
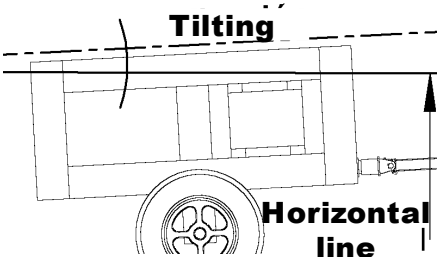
Instruction	Action	Machine area
Keep the extractor linked to the tow vehicle and use the drawbar turnbuckle to regulate the height until the support leg located in the front end can be made to touch the floor (See section 2. "Parts list").		
Release the drawbar turnbuckle and fold the foldable drawbar upwards; insert its pin in order to secure it to the chassis. Use the drawbar turnbuckle to assemble the double drawbar.		
Link the extractor to the operating vehicle. Alter that, connect the hydraulic circuit.		
Choose the "HEIGHT" position on the switch valve. Use the tractor's hydraulic system to lift the machine high enough for the wheels to be left in the air so as to make their removal easier. Precautions must be taken since the tractor could be pulled by the machine.		

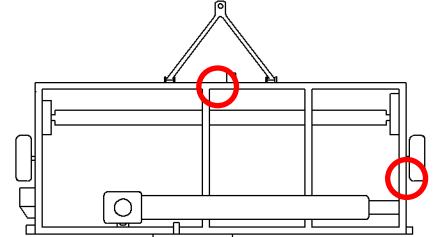
Instruction	Action	Machine area
Lift the support leg and remove the wheels from their transport position locations.		
Put the wheels in their operating position locations on the machine's ends.		
Raise the oscillating support (right wheel support) and fix it to the chassis with the pin supplied ad hoc. Tighten firmly its 4 (four) bolts in their location, or otherwise the normal operating vibration could make them loosen and get lost.		
Use the tractor's hydraulic system to lift the retractable supports completely in order to lower the machine.		
Choose the "NEUTRAL" position of the switch valve.		
The machine's chassis must be tilted so that the highest side is the tractor's side, which improves grain extraction during normal operation. Operate the drawbar turnbuckle to achieve such tilting.		
Connect the drawbar to the tractor's PTO including the corresponding guards. Connect the electrical circuit too, and the machine will be ready to start operating.		

5. SET UP FOR EXTRACTION

5-a. General Comments on the Storage in Grain bags

The storage of dry grain in grain bags is commonplace among rural producers, who regard this system for the conservation of grains to be flexible and economical, since important product commercialisation costs can be eliminated as regards the storage carried out by third parties.

However, the effectiveness of this storage system largely depends on the control performed on the conservation conditions of the grain inside the grain bag, on the operating method used to bag the product and the method used for its extraction. This is why **Micrón Fresar S.R.L.** includes in the present manual a number of recommended operating rules based on the experience gathered from several rural producers. Besides, an important number of safety warnings are included; they are based on in-depth technical analyses carried out by specialists according to the safety standards in force as regards agricultural machinery of this type.

Therefore, it must be noted that both the order and the details of each one of the explained operations and procedures should be respected, since the success of the extraction operation in itself depends on it, as well as the maintenance of adequately safe conditions for the operators and all the equipment related to the extraction operation. The user is responsible for thoroughly studying the present operation and maintenance manual, paying special attention to all the warnings included in each section and to the contents of paragraph 1.g. "Safety"

5-b. Recommendations to Make Extraction Easier

The bagging machine **AKRON® model E 9250 FH Y FHH** has the grain extractor **AKRON® model E 180 TH** as an ideal complement, and the extractor requires some conditions in the layout and preparation of the grain bags.

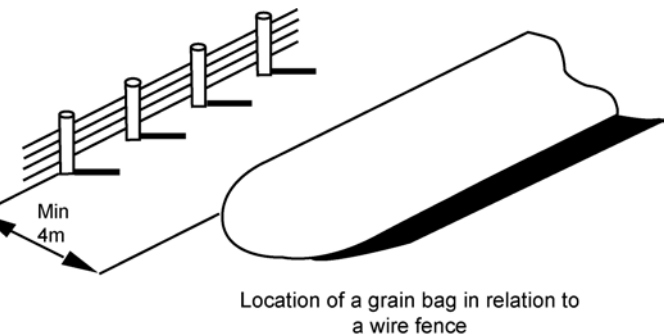

If a grain bag is prepared next to a wire fence, a 4-metre clearance must be kept, taking into account that the extractor loads a vehicle moving along to the right-hand side from the point of view of the tractor driver.

If two or more grain bags have to be placed parallel one to the other, at least 1 (one) metre should be left between them in order to work with room to spare during the extraction. However, the most important precaution is to anticipate that the first bag can be easily accessed from the side where the grain transport vehicle must move.

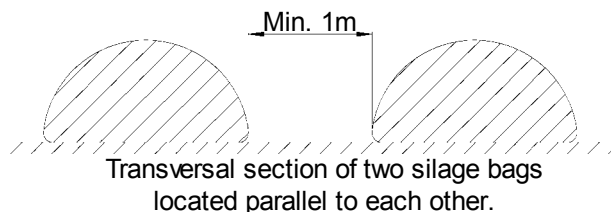

If the grain bag is closed on its initial end using two pieces of wood or plastic seals, less remaining cereal will be left to remove manually at the end of the extraction process.

5-c. Previous Controls on the Machine

Before setting up the machine for the extraction process the following controls will have to be carried out:

- Make sure that all the parts of the machine are prepared according to its operating position, as indicated in Section 4 – “Position changes”
- Check the oil level in all the machine’s drive and transmission gearboxes. The detail of their components is given in section 9. “Assemblies”. The machine should never be operated if there is not enough oil inside all the gearboxes, since this would result in serious mechanical damage to all these transmission components.
- In all cases, if it were necessary to add oil, only SAE 90 must be used. The quality of the oil should never be altered, since this would result in problems for the performance and lifespan of the gearbox components

5-d. Machine Layout

Once the extractor is ready in its operating position, it must be placed facing the grain bag in the following way:

- 1) Align the extractor with the tractor and the grain bag as shown in the figure. These three elements should be as centred and aligned as possible, since this will make the extraction operation easier.

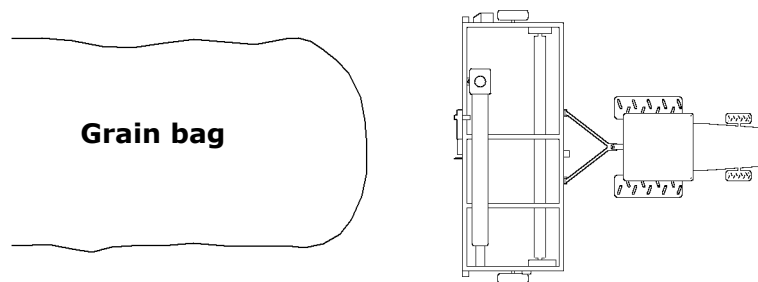

- 2) Remove the lock pin that keeps the lifting auger fixed to the chassis. To prevent this pin from getting lost during normal operation, it is highly advisable to locate it at the end of the oscillating support (right wheel support), which is free at that moment.
- 3) Make sure that the hydraulic switch valve is in the “TUBE” position.

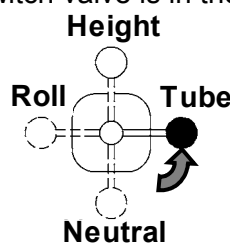

- 4) Clear the area below the tube.
- 5) Lift the tube to its operating position using the tractor’s hydraulic system. Check that no person or equipment interferes with the tube in order to prevent dangerous trapping or hitting risks.
- 6) Turn the switch valve to the “ROLL” position.

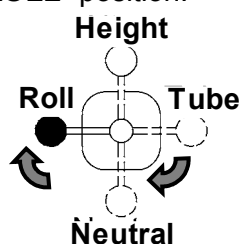

5-e Grain Bag Preparation

If it is possible to choose, it is always more convenient to start extracting grain from the end of the grain bag where the storage was finished, since there is enough bag left in this end to fix to the machine's roll. If this option is not available, the operation can also be started from the initial end of the grain bag (see the paragraph 5-b. "Recommendations to make extraction easier").

In both cases, starting from the initial or final end, the grain bag has to be opened as explained below. However, when the extraction starts from the initial end, some grain will have to be removed manually until enough grain bag material is left to fix to the extractor's roll. Follow the instructions given in title 6-e. "Extraction at the end of the grain bag" for manual grain extraction

- 1) The bag must be opened with extreme care, since any longitudinal slash on the bag's top, the most stretched part of it, could result in the bag opening completely. To avoid such risk, it is advisable to work according to the following procedure:

Make a short transversal cut, about 20 cm long, about 2 m from the end of the bag. This cut will be more or less at the same height as the extractor's cutting blade.

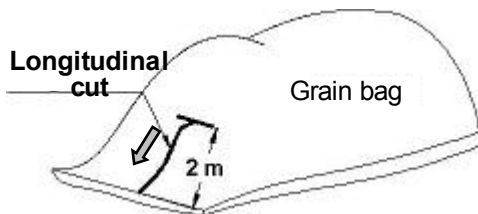
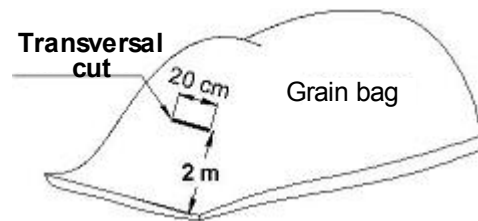

From the middle of the previous cut, slash the grain bag longitudinally up to its end.

Open this last cut to the sides, so that the cereal shows.

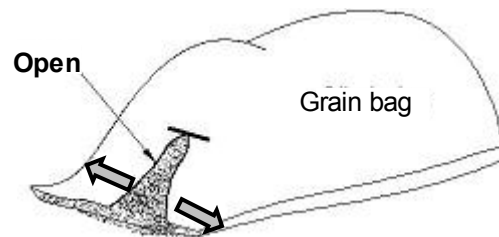

- 2) If there is not enough material to fix the grain bag to the extractor's roll, it is convenient to extract some of the cereal manually, using shovels, until enough plastic is available. Most of the times, this operation will be unavoidable when the extraction starts from the same end where the storage was started.
- 3) Make sure there are no people or gear around the area in order to avoid any kind of damage. Reverse the machine using the tractor until the cereal starts to cover the horizontal augers. It is important to avoid exerting too much pressure on the cereal mass, since this may result in excessive, unnecessary efforts on the extractor.
- 4) Make sure that the machine's cutting blade is aligned with the cut previously made by hand. The cutting blade's cover will have to be lifted to this effect.

5-f. Final Adjustments on the Machine

First of all, the cardan shaft should not be operated before the grain bag is fixed to the roll. Otherwise, the augers would start moving and the grain bag could get entangled in them.

- 1) Completely close the flow control valve, and then open it half a turn, that is, 180°.

Flow control valve

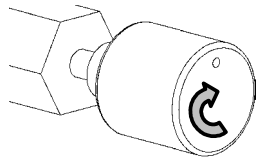

Close (clockwise)

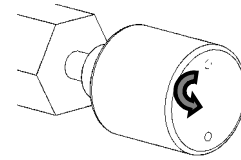

Open ½ Turn (counterclockwise)

- 2) Turn the roll using the tractor's hydraulic system until the fixing screws reach the position shown in the figure.
- 3) To fix the bag to the roll, both the upper and lower sides of the bag should easily reach the whole breadth of the roll on its fixing screws
- 4) Pierce both sides of the end of the grain bag with each of the 7 (seven) fixing screws, checking that all the threaded holes are easily reachable. Otherwise, it will become difficult to fit them.

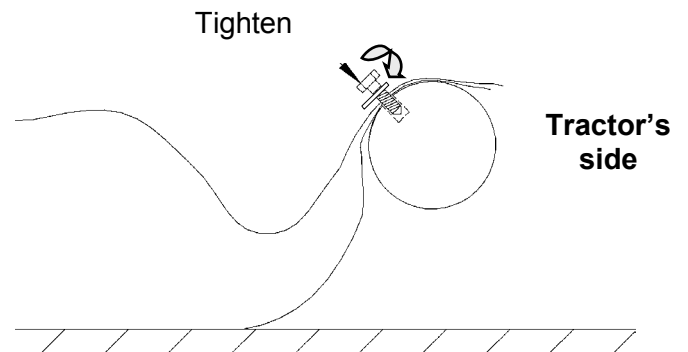
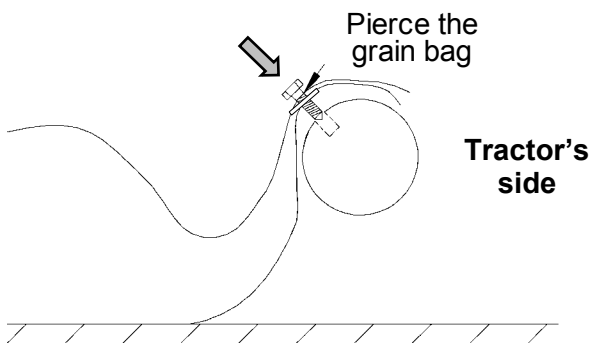
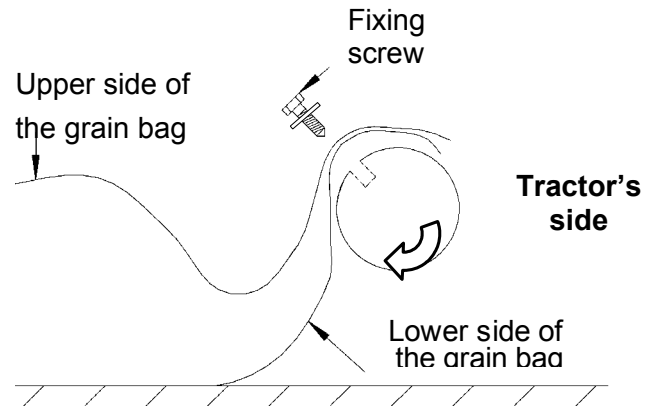

- 5) Fit and fasten the 7 (seven) screws on the roll.
- 6) Check once again that the machine's cutting blade is aligned with the cut previously made on the top of the bag. If the cut on the grain bag were not continued normally, the extractor would be subjected to excessive efforts and the grain bag would run the risk of being torn. If the cutting blade stops cutting, a small transversal cut must be made on the grain bag in order to align it with the blade by means of a longitudinal cut as shown in the following figures:

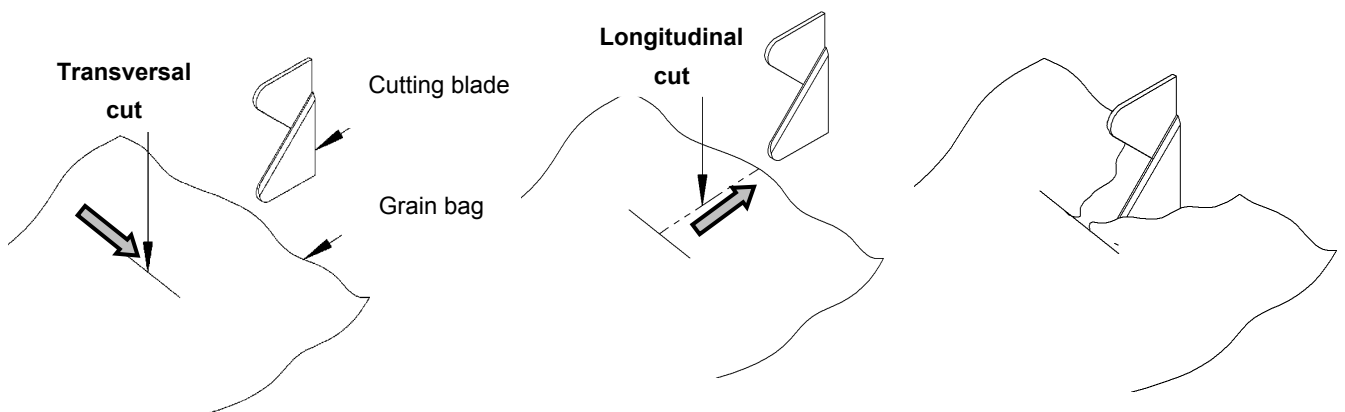

6. EXTRACTION PROCESS

6-a. Operation Start-up

With the machine and the grain bag prepared as explained in the previous section, the extraction can be started, taking into account the following steps:

- 1) The following figure shows the layout of all the equipment involved in the extraction process.

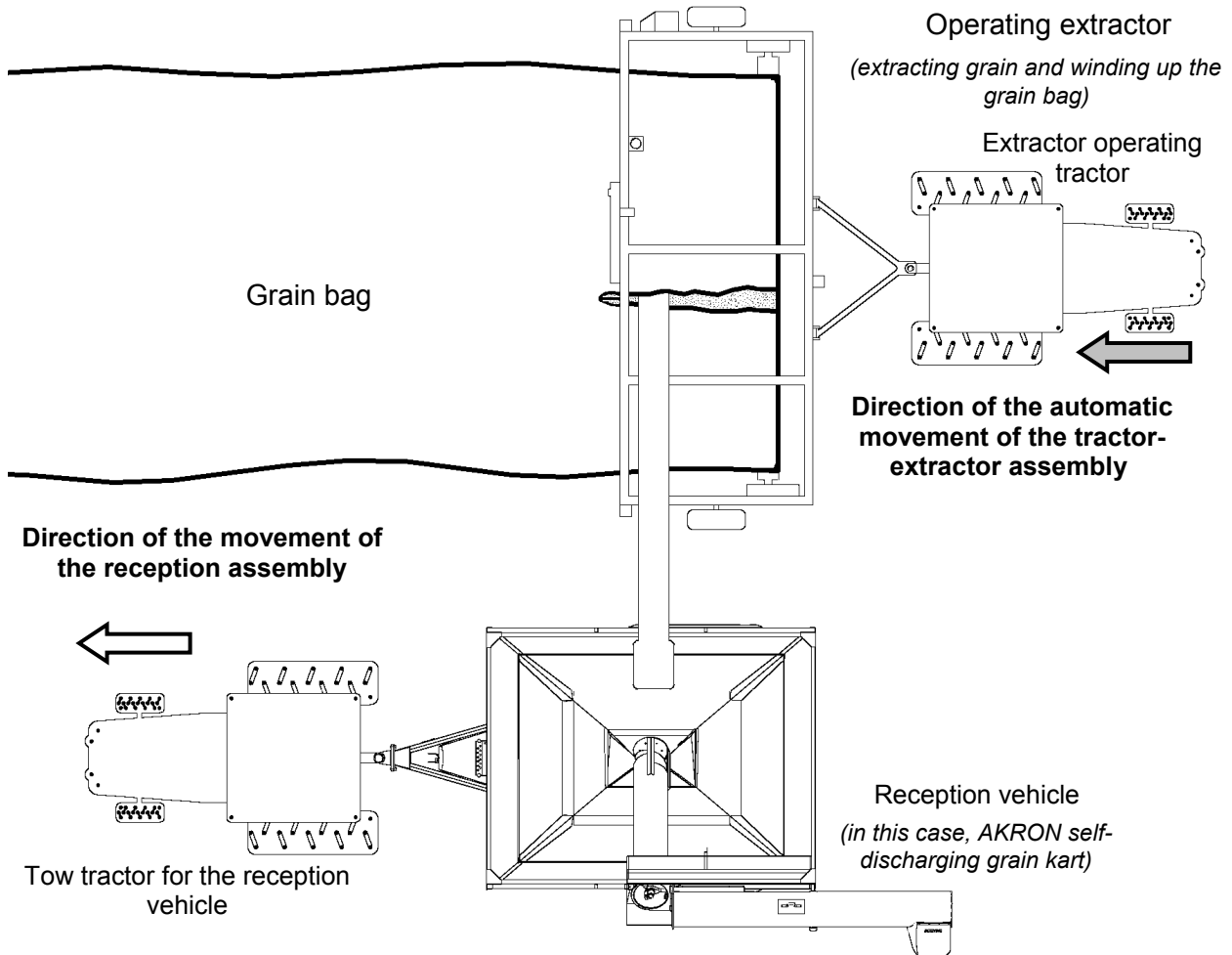

- 2) Make sure that the extraction tube's outlet is located over the vehicle where the grain is to be loaded.

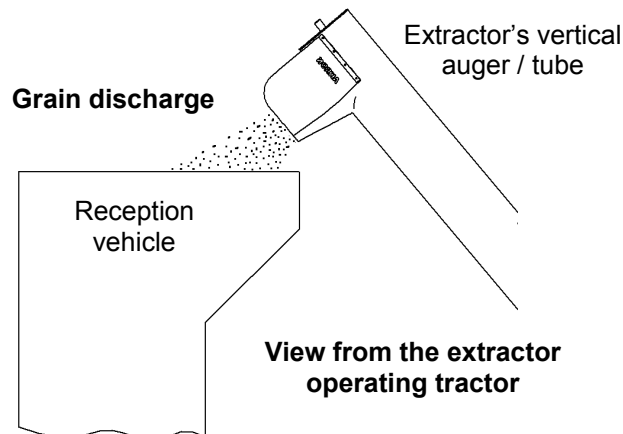

- 3) Activate the cardan shaft, slowly at the beginning. This way, the cereal starts to flow upwards. Gradually increase the speed until it reaches 540 rpm on the cardan shaft.
- 4) Make sure that the tractor is not geared and that the hydraulic system is ready to operate.
- 5) With the cardan shaft already turning, hydraulically activate the traction roll in the direction given by the arrow shown in the figure. Using the flow control valve, gradually increase the speed until a reasonable rate is reached (remember that by this time the machine has started moving, tugging the tractor behind it). The idea is to work at a speed high enough to reach a good efficiency, but not excessive, since this would result in the cereal getting trapped inside the bag as it is wound on the roll. The following figure shows an ideal situation, where the cereal level stays invariable inside the bag.

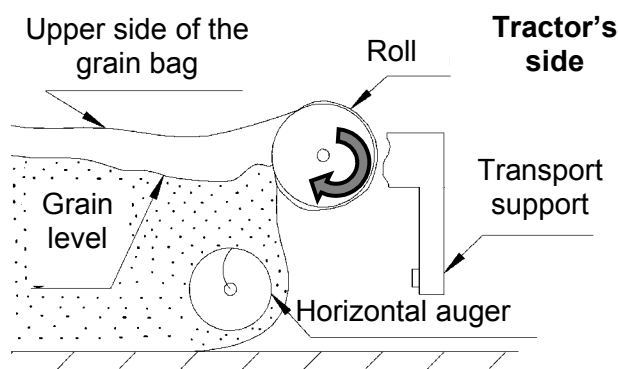

- 6) Increase the cardan shaft speed up to 540 rpm. To prevent the grain from getting crushed and the augers from wearing out prematurely, do not work at speeds higher than this.
- 7) Make sure once again that the machine's cutting blade is still opening the bag following the original cut. If it was necessary, make a new cut, always transversally (see item 5 within title 5-f. "Final adjustments on the machine").

6-b. Operation Parameters

- 1) As the extraction is carried out, the machine's feed speed can be adjusted using the flow control valve. This valve operates directly on the roll's winding speed, and consequently varies the speed with which both the tractor and the extractor move. Every time the speed has to be adjusted, it must always be done gradually, avoiding sudden variations that could overload the hydraulic system.
- 2) During the machine's normal operation, a small "mound" or pile of cereal is formed under the roll. The upper part of it, in the centre, must never be above the roll's height. If this happened, some grain would get trapped inside the bag as it is wound onto the roll. This situation is corrected by opening or closing the flow control valve, thus increasing or reducing the roll's speed.
- 3) The roll's height (h) over the ground must be enough to avoid the accumulation of an excessively large "mound" under the roll. Otherwise, the bag may probably be torn by the transport support, in the rear part of the machine. In order to adjust this height, the draw-bar turnbuckle must be manipulated until the "mound" disappears.

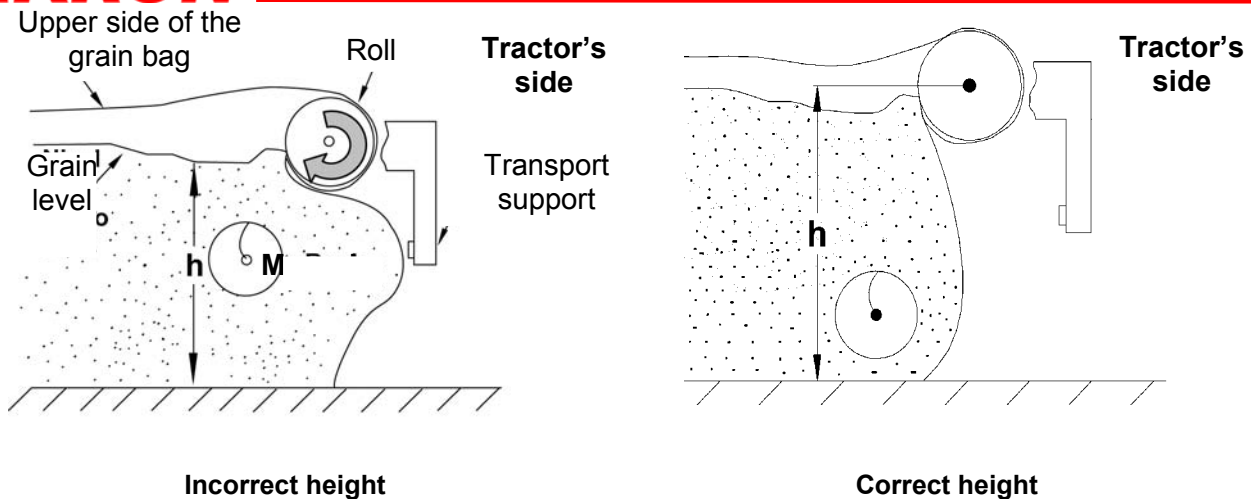

6-c. Protection against Overloads

The machine has 2 (two) 3/8" bolts grade 5, which act as mechanical fuses, so they will break if the roll is subjected to any kind of mechanical overload. Likewise, the transmission chain connecting the roll and the reduction gearbox can also break.

These components should never be modified under any circumstances, since they guarantee the machine's good condition and correct operation. The breaking of any of these fuses definitely indicates that the machine was subjected to an extraordinary effort. If these bolts break repeatedly, research should be carried out to determine the causes.

Such efforts could probably be caused by the following conditions, which must be **specially avoided**:

- 1) Excessively heavy tractor.
- 2) Articulated tractor.
- 3) The tractor's steering wheels turned up to their maximum limit. This situation turns them into an "anchor" that tends to immobilise the tractor together with the extractor.
- 4) The roll was turned without extracting any cereal.
- 5) The feed speed is higher than the one needed by the cereal to flow through the augers.

6-d. Interruptions during Extraction

If it were necessary to bring the extraction to a halt, for example once a wagon or lorry is full, the following instructions should be followed:

- 1) **ALWAYS** turn off the hydraulic system first (this stops the roll's rotation) In order to avoid damages due to the effects of inertia, the tractor driver should be ready for the tractor-extractor assembly to stop as soon as the hydraulic system is disconnected.
- 2) Only then let the augers work for a few seconds so that the bag is decompressed. This way, overloads during restart will be avoided.
- 3) Finally, after this short time, the cardan shaft can also be stopped.

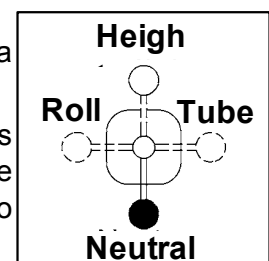

It is very important to follow always the given order for this procedure, since otherwise the bag would continue to be wound without cereal extraction, which would cause damage and / or breakdowns to the machine.

To restart the extraction process, the order of the instructions is exactly the other way round, that is, operating first the augers and last the hydraulic system. This way, the cereal is removed to decompress the bag, and this makes it easier for the machine to start moving again.

6-e. Extraction at the End of the Bag

It is important to reach the end of the bag with the machine working as centred as possible.

- 1) Grain can be extracted until the augers touch the inner side of the end of the grain bag. The roll must be stopped as soon as this happens, and only then can the augers also be stopped.
- 2) Once the mechanical extraction has stopped completely, the machine will have to be pulled away from the bag. To achieve this, the direction of the roll movement must be inverted by switching the lever of the tractor's hydraulic system. By unwinding part of it, the bag is relieved of the pressure exerted by the cereal on the bag's sheet.
- 3) After enough length of the grain bag has been unwound, it can be cut in order to fully separate the remaining cereal left on the ground from the rest of the grain bag wound on the machine's roll. For a more convenient operation, the machine can be towed away for a few metres using the tractor linked to it.
- 4) Reverse the tractor with the machine again and bring the augers as close as possible to the remaining cereal.
- 5) Close the two covers protecting the lower part of the lifting auger and fix the manual loading funnel furnished with the machine.
- 6) Operate the augers and shovel the remaining grain into the funnel.

Under normal conditions, and following all the instructions given, no more than **200 kg** of cereal should be left for this manual task.

6-f. Unwinding the Bag

The extractor includes a system to uncouple the roll located on the inner side of the chassis. The following pictures explain its operation. Stop the tractor and remove the key before working inside the machine or on top of it in order to prevent serious accidents from happening.

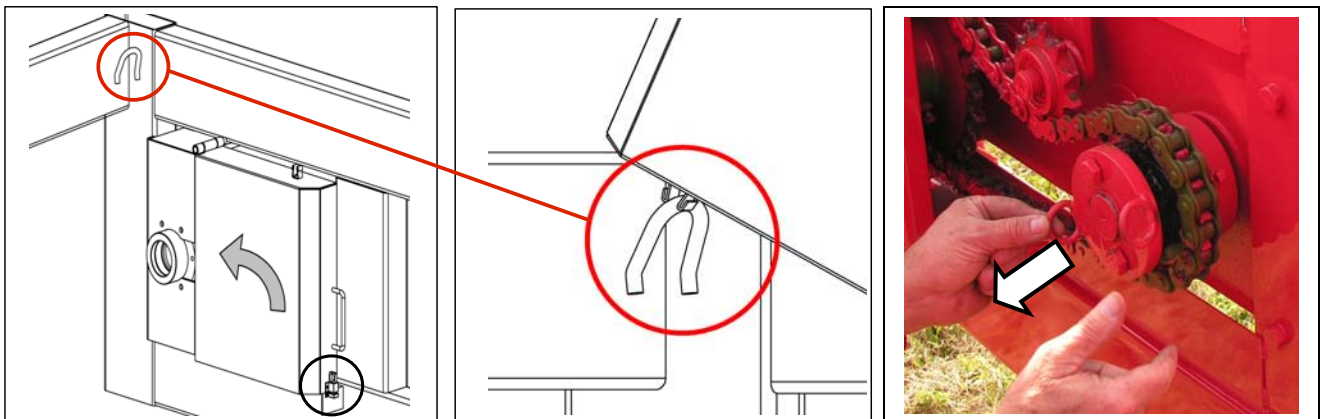

To remove the protection cover, pull the lower lock upward to unlock it

View of the lock when the protection cover is open

Carefully introduce both index fingers in the welded rings and pull outwards.

This way the roll can rotate freely, which allows the grain bag to be unwound just by moving the tractor forward. If it were necessary, the grain bag should be held by some appropriate means while it is being unwound.

The unwinding process is exactly the same if cereal is extracted from only part of a bag. The only difference is that the remains of the bag must be used to seal it back, always caring for cereal conservation.

7. PREPARATION OF THE MACHINE FOR TRANSPORT

The steps described below should be followed in order to change the machine from its operating position to its transport position.

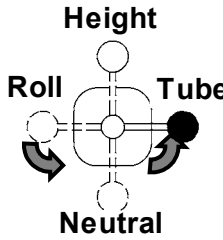
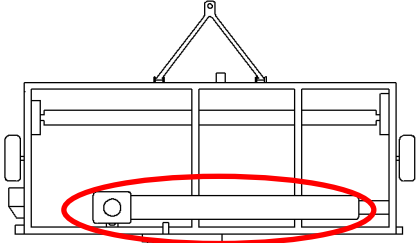
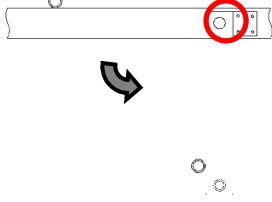
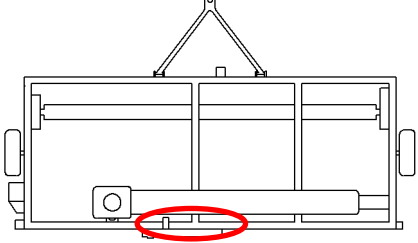
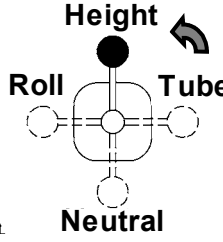
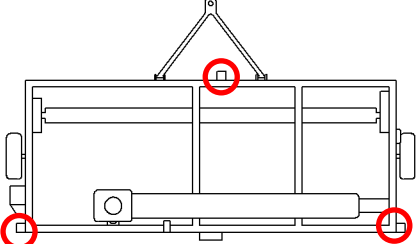
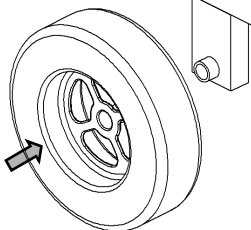
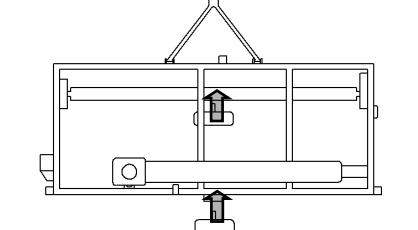
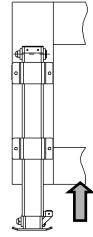
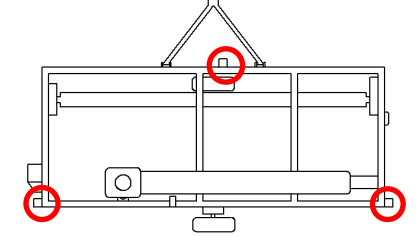
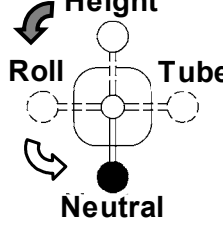
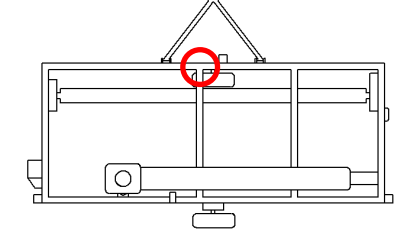
Instruction	Action	Machine area
<p>Using the tractor's hydraulic system, lower the tube to its rest position and fix it using the lifting auger lock pin. Close the auger covers if they are open. Check that no person or equipment interferes with the tube in order to avoid dangerous trapping or hitting situations.</p>		
<p>To lower the oscillating support (wheel support) remove the pin that holds it in its place. Tighten firmly its 4 (four) bolts in their location. Insert the pin in its original location to prevent it from getting lost.</p>		
<p>Choose the "HEIGHT" position on the switch valve. Use the tractor's hydraulic system to lift the machine high enough for the wheels to be left in the air so as to make their removal easier. Precautions must be taken since the tractor could be pulled by the machine.</p>		
<p>Remove the wheels from their operating position locations and insert them into their transport position locations.</p>		
<p>Use the tractor's hydraulic system to lift the retractable supports completely in order to lower the machine.</p>		
<p>Choose the "NEUTRAL" position of the switch valve.</p>		

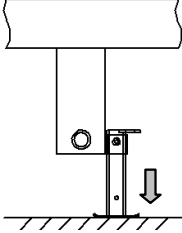
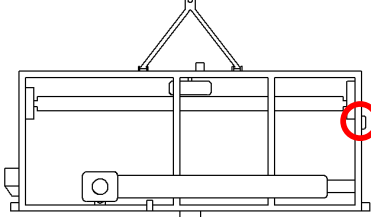
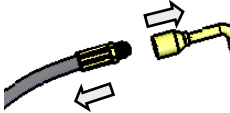
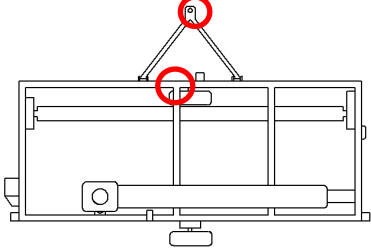
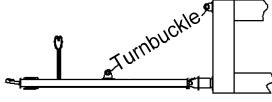
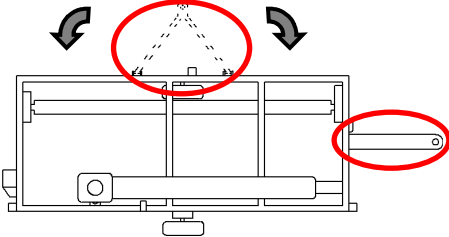
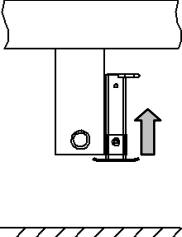
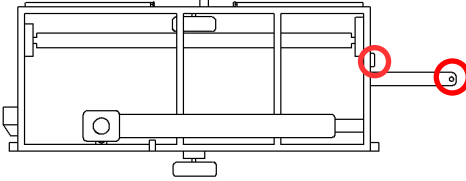
Instruction	Action	Machine area
<p>Keeping the extractor linked to the tow vehicle , the drawbar turnbuckle must be used to regulate the height until the support leg located in the front end can touch the floor.</p>		
<p>Disconnect both the hydraulic system and the electrical system. Uncouple the cardan shaft. Disconnect the tow vehicle.</p>		
<p>Release the drawbar turnbuckle and disassemble both parts of the double drawbar. After the drawbar turnbuckle has been released, unfold the foldable drawbar and prepare it to link the machine to the tow vehicle.</p>		
<p>Link the tow vehicle. Regulate the drawbar turnbuckle until the support leg can be lifted. Connect the electrical circuit and position the safety lights. The machine is ready for transport.</p>		

8. MAINTENANCE PROGRAM

Due to the simplicity of this machine's mechanisms, the only necessary maintenance tasks are the ones detailed below. They are based on a normal machine operation.

The effectiveness of the maintenance program depends on the written records kept for each one of the activities carried out on the machine.

8-a. General Maintenance

Frequency: daily or before beginning any working day

Condition to verify	Normal situation	Correction method
General machine condition	Free movements in general, reasonable cleanliness of the main components.	Eliminate the causes of possible restrictions imposed on the movements; remove any dirt that could hinder the machine's operation.
Condition of the vertical auger and horizontal augers	Free from obstructions or excessive dirt	Eliminate possible obstructions or dirt located inside the tube or on the horizontal augers
Tyre pressure	Between 35 and 40 lb/in ² (2,5 and 2,8 kg/cm ²)	Adjust tyre pressure
Condition of the lights	Correct operation of all the lights	Change of the lamp or repairs on the circuit, as necessary

Frequency: every six months

Condition to verify	Normal situation	Correction method
Condition of hydraulic circuit hoses and tubes	Hoses and tubes without leakages or serious wear	Change the defective element

8-b. Lubrication

Part or assembly	Location	Lubrication frequency
Drive chain	<ul style="list-style-type: none"> Under the chain cover 	Every 50 hours (*)
Universal joints	<ul style="list-style-type: none"> Cardan shaft 	Every 50 hours
Sleeve	<ul style="list-style-type: none"> Vertical auger hinge End of the hydraulic cylinder operating the vertical auger 	Every 50 hours
Grooved sleeve	<ul style="list-style-type: none"> Inlet to the angular gearbox 	Every 100 hours
Drawbar adjustment ratchet	<ul style="list-style-type: none"> Drawbar 	Every 100 hours
Bearings	<ul style="list-style-type: none"> On the upper horizontal drive shaft End of secondary vertical auger 	Every 100 hours
Drive gearbox 98 Angular gearbox Reduction gearbox	<ul style="list-style-type: none"> Inside the chassis 	Every 300 hours
Wheel hub	<ul style="list-style-type: none"> Axle 	Every 300 hours
Lower drive chain	<ul style="list-style-type: none"> Under the chain cover, at the beginning of the vertical auger 	Every 600 hours (*)

The use of lithium grease # 2 NLGI 2 is recommended for the lubrication ports and SAE 90 oil is recommended for the gearboxes.

(*) Check chain tension every time they are lubricated and correct as necessary.

9. SPARE PARTS LIST

The main assemblies of the AKRON® model E 180 TH mechanical grain extractor are detailed in the following pages. To order a spare part for your machine, do the following:

- Use the attached exploded diagrams to identify the component/s to be replaced.
- Note the code of each part and, if possible, the name of each assembly.
- Order the spare parts from your nearest AKRON® Technical Representative or to AKRON® Spare Parts Service (see 9-a. "Information to Obtain Spare Parts"), indicating each part's code and, if possible, the name of each assembly.
- If replacing a part that originally included safety decals, check that these are also present on the replacement part.

9-a. Information for Obtaining Spare Parts

AKRON® Spare Parts Service
Micrón Fresar S.R.L.
Rosario de Santa Fe 2256
X2400EFN - San Francisco (Córdoba)
ARGENTINA
Tel.: ++54 3564 435900 (rollover lines)
Toll free 0 800 333 8300 (in Argentina)
e-mail: ventas@akron.com.ar
www.akron.com.ar

The nearest AKRON® Technical Representative can also be contacted to obtain machine components.

AKRON® GRAIN EXTRACTOR model E 180 TH			
TRANSMISSION			
COMP. #	PART NUMBER	NAME	QTY.
1	99.388.100254	ASA 80 1" ROLLER CHAIN	2.08 Mts.
2	27.39.80504	SECONDARY INLET GEAR WHEEL	1
3	98.755.355540	UC 208 BALL BEARING	2
4	06.41.00140	AM-40 CAST IRON SUPPORT	2
5	27.42.80136	AM-40 SUPPORT BASE	1
6	27.43.80516	POWER INLET SHAFT	1
7	27.39.80166	INLET SHAFT SUPPORT	1
8	27.39.80463	GEAR WHEEL FOR COUPLING Ø 40 MM	2
9	99.388.200190	ASA 60/2 CHAIN – 56 x 19.05 MM	38 Cm. x 2
10	27.39.80460	GEAR WHEEL FOR COUPLING Ø 38 MM	2
11	98.321.000250	EXT. RET. RING FOR SHAFT Ø 25 MM	1
12	27.43.80195	REDUCTOR GBX.-ROLL CHAIN TENSIONER	1
13	98.705.205875	6005 2RS RIGID BALL BEARING	2
14	98.322.000470	INT. RET. RING FOR HOLE Ø 72 MM	1
15	29.39.25984	PLATE WITH TENSIONER SHAFT (29.42.25415 – 27.43.80508)	1
16	27.43.82535	SPLINED INLET SHAFT	1
17	29.43.25412	KEY FOR Z20 GEAR WHEEL	1
18	27.39.82501	PRIMARY INLET GEAR WHEEL Z16	1
19	29.41.25402	INLET SHAFT SUPPORT	1
20	29.43.25410	COMPENSATION WASHER	1
21	98.322.000850	INT. RET. RING FOR HOLE Ø 85 MM	2
22	98.705.207645	6209 2RS 2 RIGID BALL BEARING	3
23	27.43.80521	SHORT BEARING SPACER BUSHING	1
24	29.43.25408	9-MM-THICK WASHER Ø 26 MM	1
25	98.303.310254	23.5-MM-HIGH UNF1" CASTLE NUT	1
26	98.334.040050	Ø 4 x 50 MM SPLIT PIN	1
27	20.29.09822	MOD.98 DRIVE GEARBOX	1
28	27.43.80458	SHAFT (CONNECTING 98 GBX. & ANG. GBX.)	1
29	27.43.80453	GROOVED SLEEVE	1
30	27.46.80466	BRAKE SLEEVE	1
31	27.39.80212	RIGHTH HORIZONTAL AUGER EXTENSION	1
32	27.42.80208	HORIZONTAL AUGER END SUPPORT	2
33	06.41.00235	AP-35 CAST IRON SUPPORT	2
34	98.755.355535	UC 207 BALL BEARING	2
35	27.39.80210	RIGHTH HORIZONTAL AUGER (9')	1
36	99.388.200158	ASA 50-2 P 5/8" ROLLER CHAIN	25.5 Cm. x 2
37	27.39.80224	HUB WITH GEAR	2
38	20.29.09410	ANGULAR GEARBOX	1
39	27.42.80312	VERTICAL AUGER BASE / ANGULAR GBX.SUPPORT	1
40	27.39.80445	CHAIN TENSIONER ASSEMBLY (27.42.80307 – 27.43.80455)	1
41	27.43.80452	ASA 60/2 Z20 GEAR WHEEL	1
42	99.388.200190	ASA 60/2 CHAIN – 56 x 19.05 MM	1.14 Mts.
43	27.42.80459	VERTICAL AUGER GEAR WHEEL COVER	1
44 (A)	27.39.80211	LEFT HORIZONTAL AUGER (9')	1
44 (B)	27.39.83211	LEFT HORIZONTAL AUGER (10')	1
45	27.39.80213	LEFT HORIZONTAL AUGER EXTENSION	1

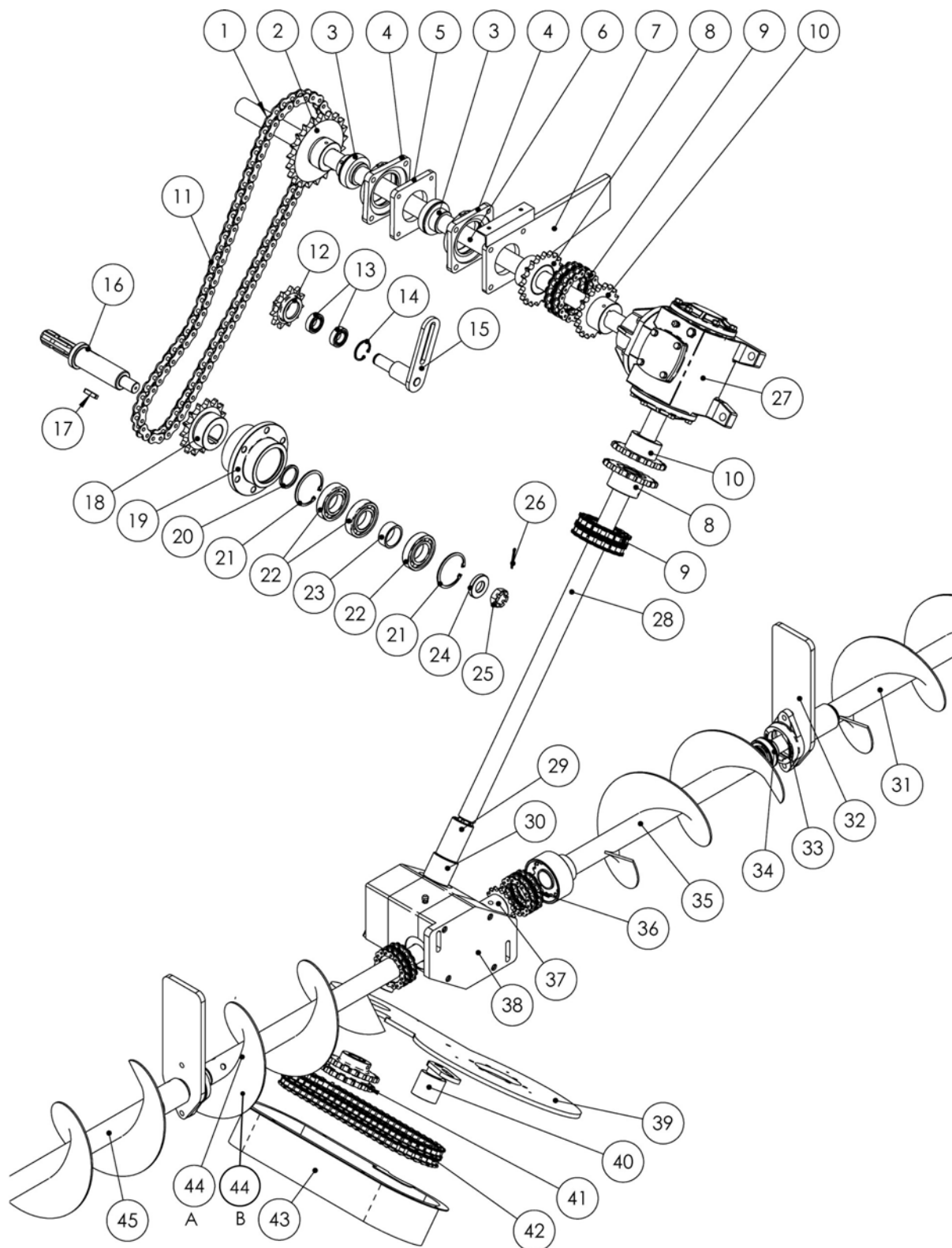

AKRON® GRAIN EXTRACTOR model E 180 TH GRAIN BAG WINDING SYSTEM			
COMP. #	PART NUMBER	NAME	QTY.
1	98.002.127032	G5 1/2" x 1.1/4" W HEX.-HEAD SCREW	6
2	98.310.100127	1/2" SPLIT LOCK WASHER	12
3	27.43.80417	STOP WASHER FOR END BUSHING	1
4	27.43.80416	ROLL END EXTERNAL BUSHING	1
5	98.755.355545	UC 209 BALL BEARING	1
6	98.301.150127	G5 1/2" HEXAGONAL NUT	4
7	06.41.00145	AM-45 CAST IRON SUPPORT	1
8	98.002.127044	G5 1/2" x 1.3/4" W HEX.-HEAD SCREW	4
9	27.43.80415	ROLL END INTERNAL BUSHING	1
10	27.39.82402	GRAIN BAG WINDING ROLL WITH SHAFT END & DISC	1
11	27.39.82425	GEARBOX-SIDE ROLL SHAFT END	1
12	27.43.80438	ROLL SHAFT END KEY	1
13	98.610.173940	DBH 6645 SEAL	2
14	98.322.000800	INT. RET. RING FOR HOLE Ø 80 mm	1
15	98.715.316640	2208 BALL BEARING	1
16	98.002.111025	G5 7/16" X 1" HEX.-HEAD SCREW	6
17	98.310.100111	7/16" SPLIT LOCK WASHER	6
18	27.41.80408	HOUSING FOR 2208 BALL BEARING	1.37 Mts.
19	99.388.100254	ASA 80 1" ROLLER CHAIN (ROLL)	1
20	27.39.82536	GEAR WHEEL Z 26 P 1" (roll side)	1
21	98.321.000250	EXT. RET. RING FOR SHAFT Ø 25 MM	1
22	27.43.80195	RED.GBX.-ROLL CHAIN TENSIONER	1
23	98.705.205875	6005 2RS RIGID BALL BEARING	2
24	98.322.000470	INT. RET. RING FOR HOLE Ø 72 MM	1
25	98.309.100127	1/2" FLAT WASHER	6
26	98.061.079032	5/16" x 1 1/4" W STUD	1
27	27.43.82542	DRIVING HUB	1
28	29.42.25415	TENSIONER GUIDE PLATE	1
29	27.43.80194	EJE TENSORTENSIONER SHAFT	5
30	27.43.82539	GEAR WHEEL Z 17 P1"	1
31	27.39.82544	LOCK PLATE	1
32	98.001.142044	G2 9/16" x 1.3/4" W HEXAGONAL-HEAD SCREW	2
33	98.338.000079	Ø 5/16" STEEL BALL	1
34	98.342.082817	SPING LOCK PLATE	1
35	98.077.095013	W 3/8" X 1/2" FLATHEAD ALLEN SCREW	1
36	37.39.82413	GRAIN BAG DRIVING SCREW	5

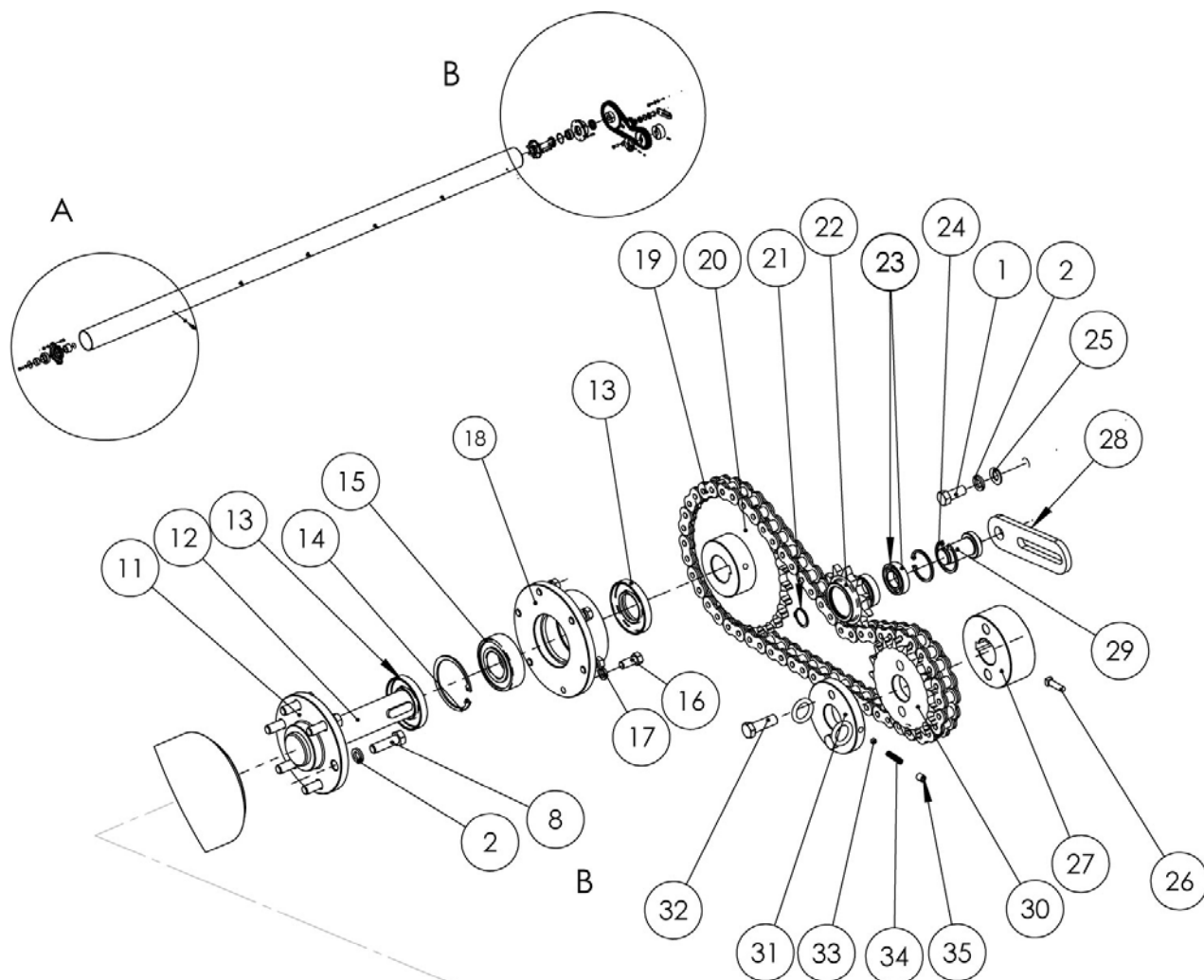

DETALLE B
ESCALA 1 : 9

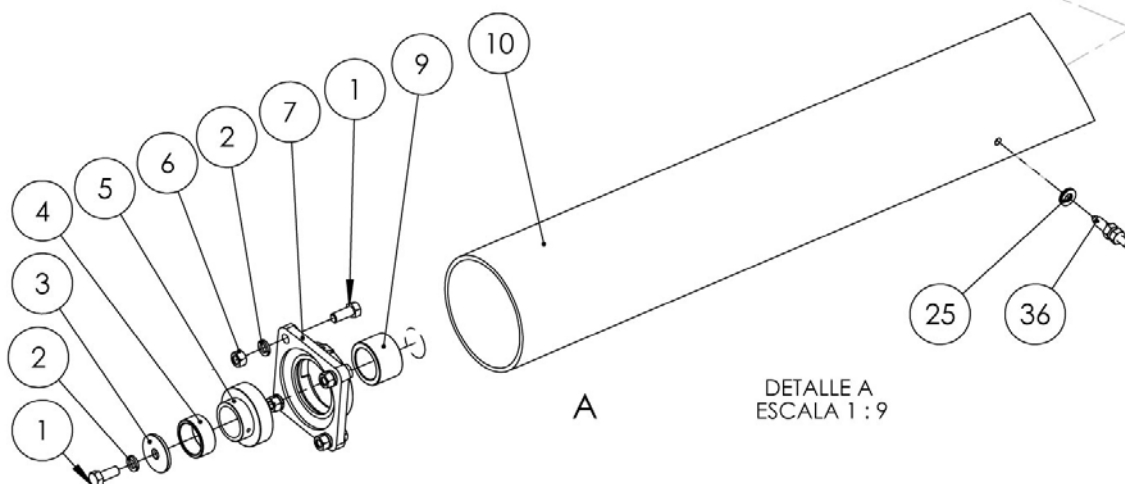

DETALLE A
ESCALA 1 : 9

AKRON® GRAIN EXTRACTOR model E 180 TH PRIMARY VERTICAL AUGER			
COMP. #	PART NUMBER	NAME	QTY.
1	27.39.80334	SHORT SLIDING COVER ASSEMBLY	1
2	27.39.80333	PRIMARY VERTICAL TUBE ASSEMBLY	1
3	25.43.14338	LOWER CYLINDER PIN	1
4	27.39.80337	3" HYDRAULIC CYLINDER ASSEMBLY	1
5	27.39.80751	FUNNEL COLLECTOR	1
6	27.39.80336	LONG SLIDING COVER ASSEMBLY	1
7	27.43.80451	ASA 60/2 GEAR WHEEL - Z19	1
8	98.713.314440	2209 BALL BEARING	1
9	27.43.80302	VERTICAL AUGER SUPPORT	1
10	98.610.174845	SAV/DBH 5072 SEAL	1
11	98.611.176860	SAV/DBH 5278 SEAL	1
12	27.43.80303	SEAL PROTECTION COVER	1
13	27.43.80454	10X10X45 KEY	1
14	27.39.80310	PRIMARY VERTICAL AUGER ASSEMBLY	1
15	25.43.14309	PRIMARY AUGER TOP BUSHING	1
16	27.39.80339	PENDULUM ASSEMBLY	1
17	98.300.300317	12-MM-THICK 1.1/4"NF JAM NUT	1
18	27.39.80342	SUPPORT PLATE ASSEMBLY	1
19	98.755.355545	UC 209 BALL BEARING	1
20	06.41.00245	AP-45 CAST IRON SUPPORT	1
21	25.39.14370	MALE COUPLING SHAFT ASSEMBLY	1

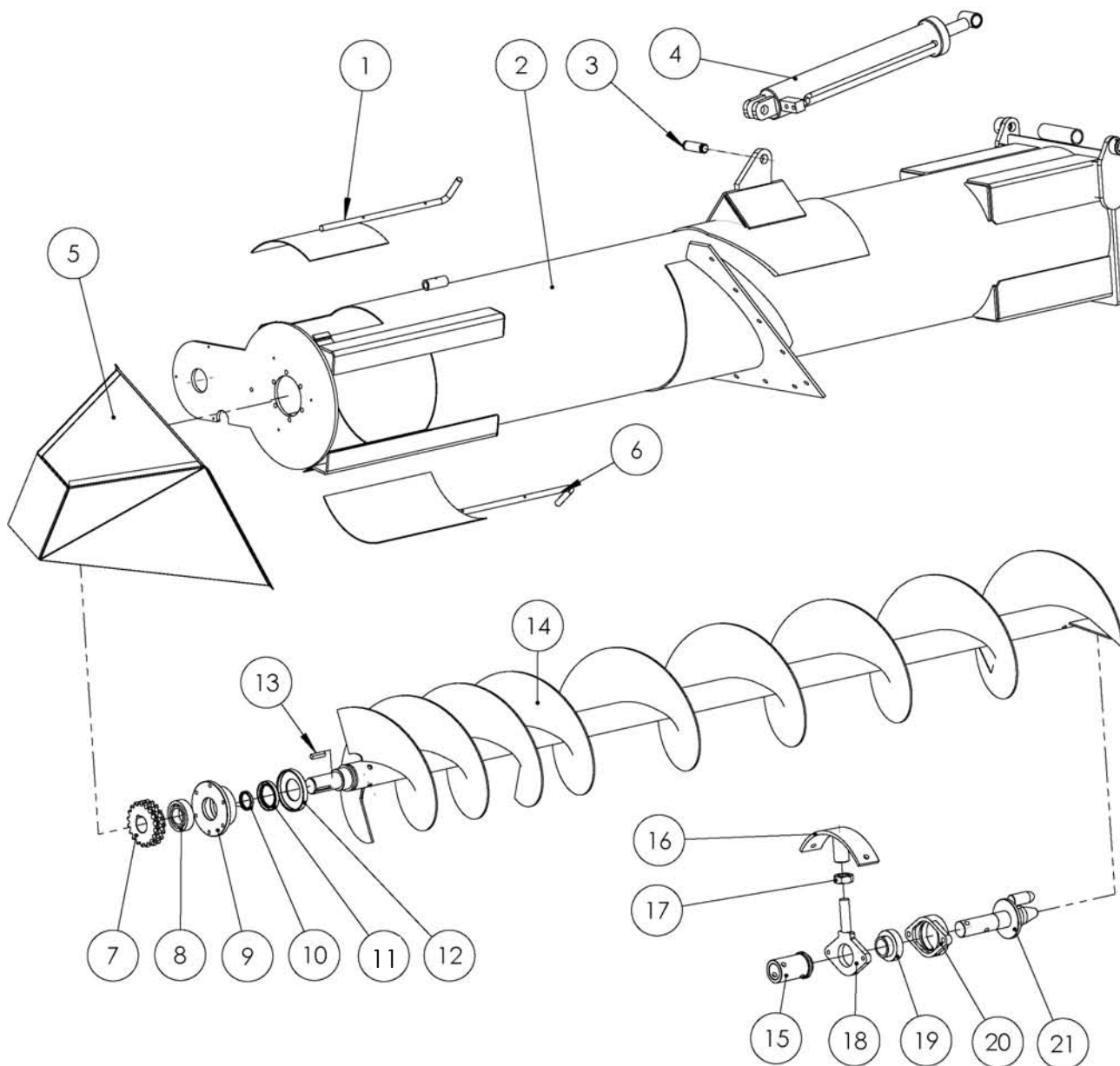

AKRON® GRAIN EXTRACTOR model E 180 TH SECONDARY VERTICAL AUGER			
COMP. #	PART NUMBER	NAME	QTY.
1	27.42.80341	GRAIN CHANNEL	1
2	98.301.150079	G5 5/16" W HEXAGONAL NUT	10
3	98.310.100079	5/16" SPLIT LOCK WASHER	10
4	98.002.079019	G5 5/16" X 3/4" W HEXAGONAL HEAD SCREW	10
5	27.39.80340	SECONDARY VERTICAL TUBE ASSEMBLY	1
6	25.42.14339	UPPER CYLINDER PIN	1
7	25.43.18306	HINGE PIN	1
8	98.329.050045	Ø 5 X 45 SPRING TENSION PIN	2
9	27.39.80311	SECONDARY VERTICAL AUGER ASSEMBLY	1
10	06.41.00145	AM-45 CAST IRON SUPPORT	1
11	25.43.14405	AUGER END WASHER	1
12	98.310.100158	5/8" SPLIT LOCK WASHER	1
13	98.002.158032	G5 5/8" X 1.1/4" W HEXAGONAL HEAD SCREW	1
14	98.002.127165	G5 1/2" X 6.1/2" W HEXAGONAL HEAD SCREW	4
15	98.342.014324	VERTICAL AUGER SPRING	4
16	98.755.355545	UC 209 BALL BARING	1
17	98.301.150127	G5 1/2" HEXAGONAL NUT	8
18	27.39.82320	LIFTING EYE	1

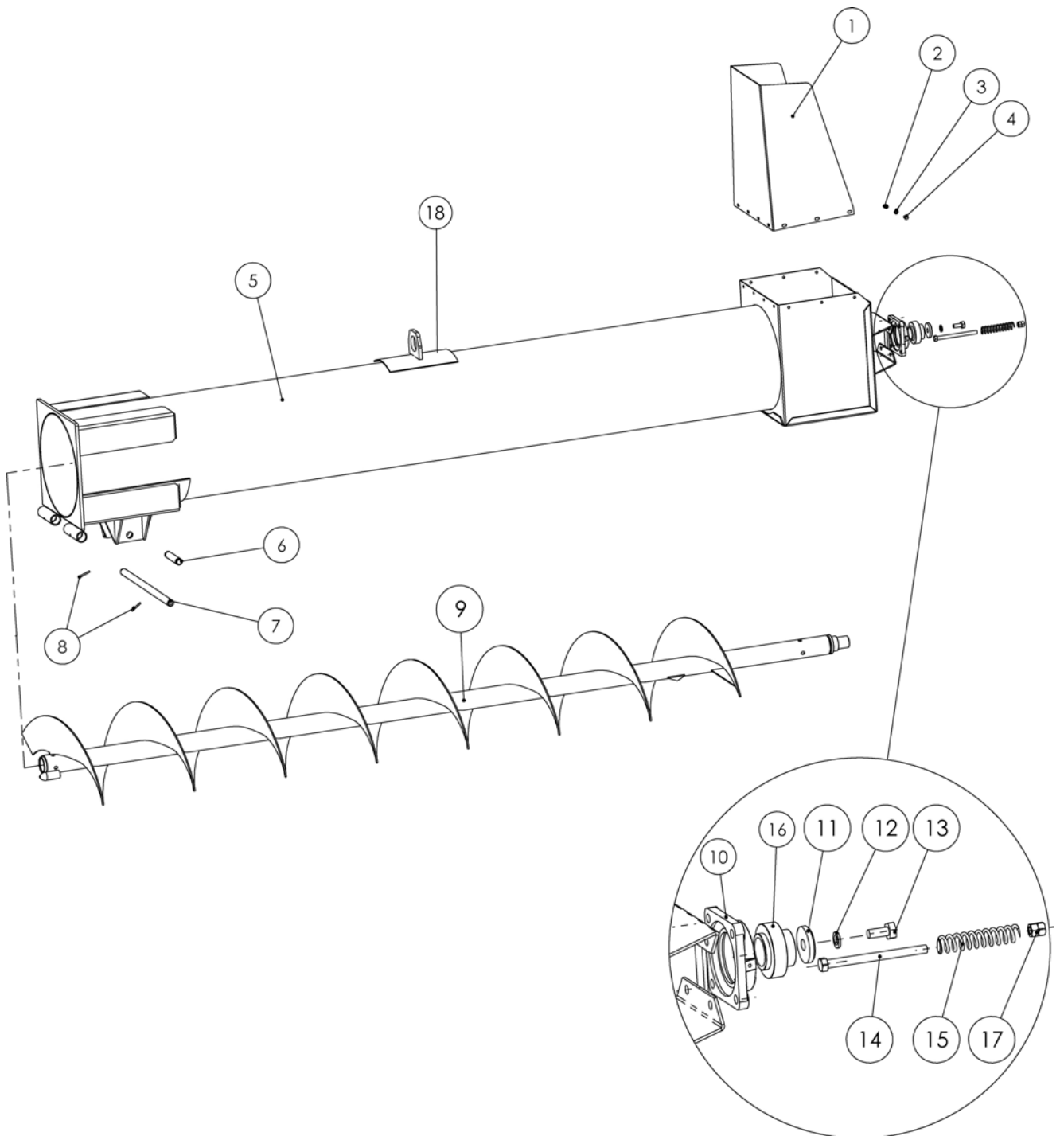

AKRON® GRAIN EXTRACTOR model E 180 TH HYDRAULIC RETRACTABLE SUPPORT			
COMP. #	PART NUMBER	DESCRIPTION	QTY.
1	98.380.040100	80-MM-LONG HAIRPIN COTTER PIN (Ø3.5 MM)	2
2	27.43.81762	SPACER BUSHING	2
3	98.378.082766	CYLINDER FOR HYDRAULIC SUPPORT	1
4	98.002.063006	1/4" x 3/8" HEXAGONAL SCREW	1
5	27.42.82765	TOP COVER	1
6	27.43.81754	BUSHING	4
7	27.43.81763	UPPER LOCK PIN	1
8	98.301.150127	G5 1/2" HEXAGONAL NUT	4
9	98.310.100127	1/2" SPLIT LOCK WASHER	4
10	98.002.127032	G5 1/2" x 1.1/4" W HEX.-HEAD SCREW	4
11	27.43.82753	OUTER TUBE	1
12	25.39.14280	LONG PIN WITH CHAIN, CLIP & RING	1
13	27.43.82757	CYLINDER LOCK	1
14	27.43.81764	LOWER LOCK PIN	1
15	27.42.82756	LOCK LATCH	1
16	27.42.82758	BASE FOR HYDR. SUPPORT TUBE	1
17	98.328.082760	COTTER FOR HYDRAULIC SUPPORT	1
18	27.43.82759	INNER TUBE FOR HYDRAULIC SUPPORT	1
19	27.42.82763	FRONT FITTING OMEGA CLAMP	2

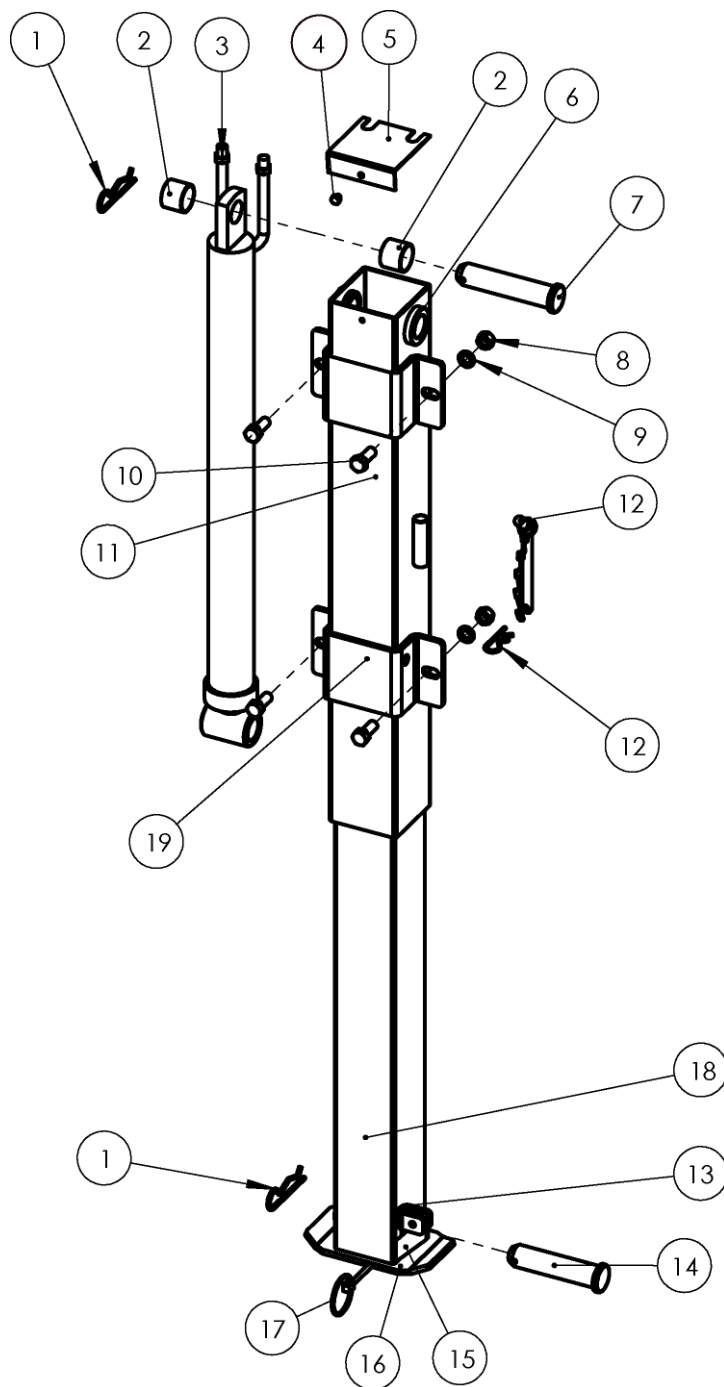

AKRON® GRAIN EXTRACTOR model E 180TH SQUARE DRIVE GEARBOX E 180 TH			
ELEM. #	PART NUMBER	NAME	QTY.
1	20.41.09860	HOUSING	1
2	20.41.09833	TOP COVER	1
3	98.310.100079	5/16" SPLIT LOCK WASHER	4
4	98.002.079019	5/16" X 3/4" HEXAGONAL-HEAD BOLT G5	4
5	20.41.09823	INLET HUB	1
6	20.39.09861	LEVEL METER PLUG	1
7	98.002.095031	3/8" X 1.1/4" HEXAGONAL-HEAD BOLT G5	18
8	20.41.09825	OPEN BEARING-HOUSING COVER	1
9	20.41.09863	CLOSED BEARING-HOUSING COVER	1
10	98.730.330840	BEARING N° 30208	4
11	98.611.173939	SEAL (SAV 5241 OR EQUIV.)	1
12	20.43.09865	OUTLET SHAFT	1
13	20.43.09864	INLET SHAFT	1
14	20.42.09816	SEALING WASHER	1
15	20.42.11514	SEALING WASHER	1
16	20.43.09808	NUT	1
17	20.43.09813	WOODRUFF KEY	2
18	98.610.176657	SEAL (SAV 5715 OR EQUIV.)	1
19	20.43.09805	INLET BEVEL GEAR WHEEL Z15	1
20	20.43.09806	OUTLET BEVEL GEAR WHEEL Z15	1
21	98.370.100972	1/8" BSP BREATHING VALVE	1
22	98.334.040070	Ø 4 x 70 SPLIT PIN	1
23	98.310.000095	3/8" SPLIT LOCK WASHER	18

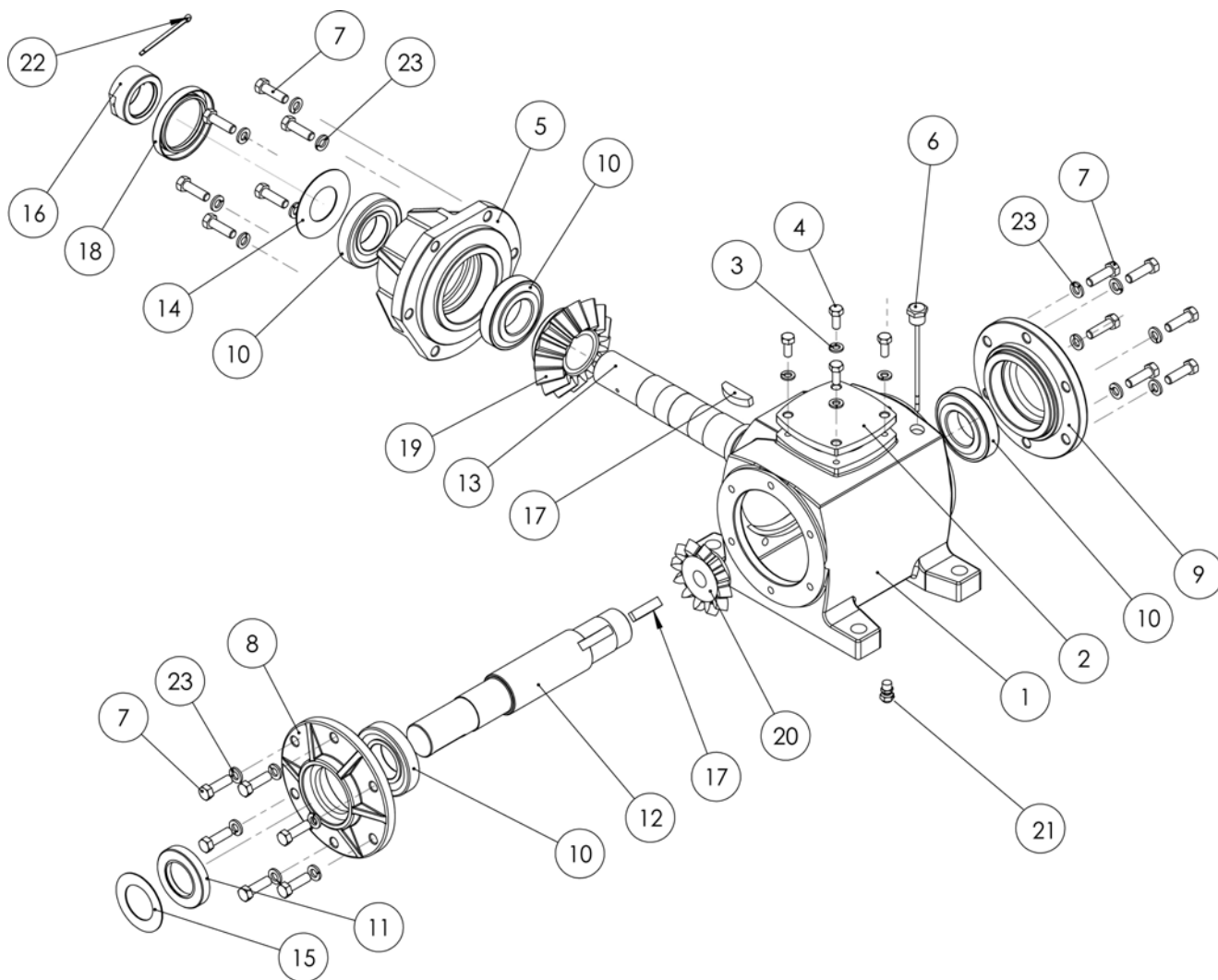

TECHNICAL DATA

- Oil type: SAE 90
- Oil volume: 2.5 litres

AKRON® GRAIN EXTRACTOR model E 180 TH REDUCTION GEARBOX E 180 TH			
ELEM. #	PART NUMBER	NAME	QTY.
1	20.39.80001	HOUSING	1
2	98.037.095089	RW 3/8" X 3.1/2" HEXAGONAL-SOCKET HEAD CAP SCREW	8
3	98.322.000720	INTERNAL RETAINING RING FOR Ø 72 HOLE	7
4	98.705.206535	RIGID BALL BEARING N°. 6207 2RS	7
5	20.43.80019	BLIND COVER	7
6	98.077.079008	5/16" X 5/16" HEXAGONAL-SOCKET GRUB SCREW	7
7	20.43.80024	1" BSPT HEXAGONAL-HEAD PLUG	1
8	13.43.11051	3/8" BSPT PLUG	2
9	20.43.80015	Ø 35 SPACER RING	1
10	20.43.80008	GEAR WHEEL - Z23 (DH100 MOTOR)	1
11	27.43.80457	STOP WASHER	1
12	98.007.080025	M 8x1.25x25 HEXAGONAL-HEAD BOLT G5	1
13	20.43.80011	GEAR WHEEL: Z85 - M2	1
14	20.43.80021	10X10X22 KEY	1
15	20.43.80004	PRIMARY SHAFT WITH GEAR WHEEL - Z21	1
16	98.321.000350	EXTERNAL RETAINING RING FOR Ø 35 SHAFT	2
17	20.43.80017	SEAL-HOUSING COVER	1
18	98.322.000800	INTERNAL RETAINING RING FOR Ø 80 HOLE	1
19	98.610.173840	SEAL (SAV-DBH 5148 OR EQUIV.)	1
20	98.705.206640	RIGID BALL BEARING N°. 6208 RS	1
21	20.43.80023	Ø 40 SPACER RING	1
22	20.39.80237	OUTLET SHAFT ASSEMBLY	1
23	20.39.80036	3 RD SHAFT ASSEMBLY	1
24	20.39.80035	2 ND SHAFT ASSEMBLY	1
25	98.370.100972	1/8" BSPT BREATHING VALVE	1

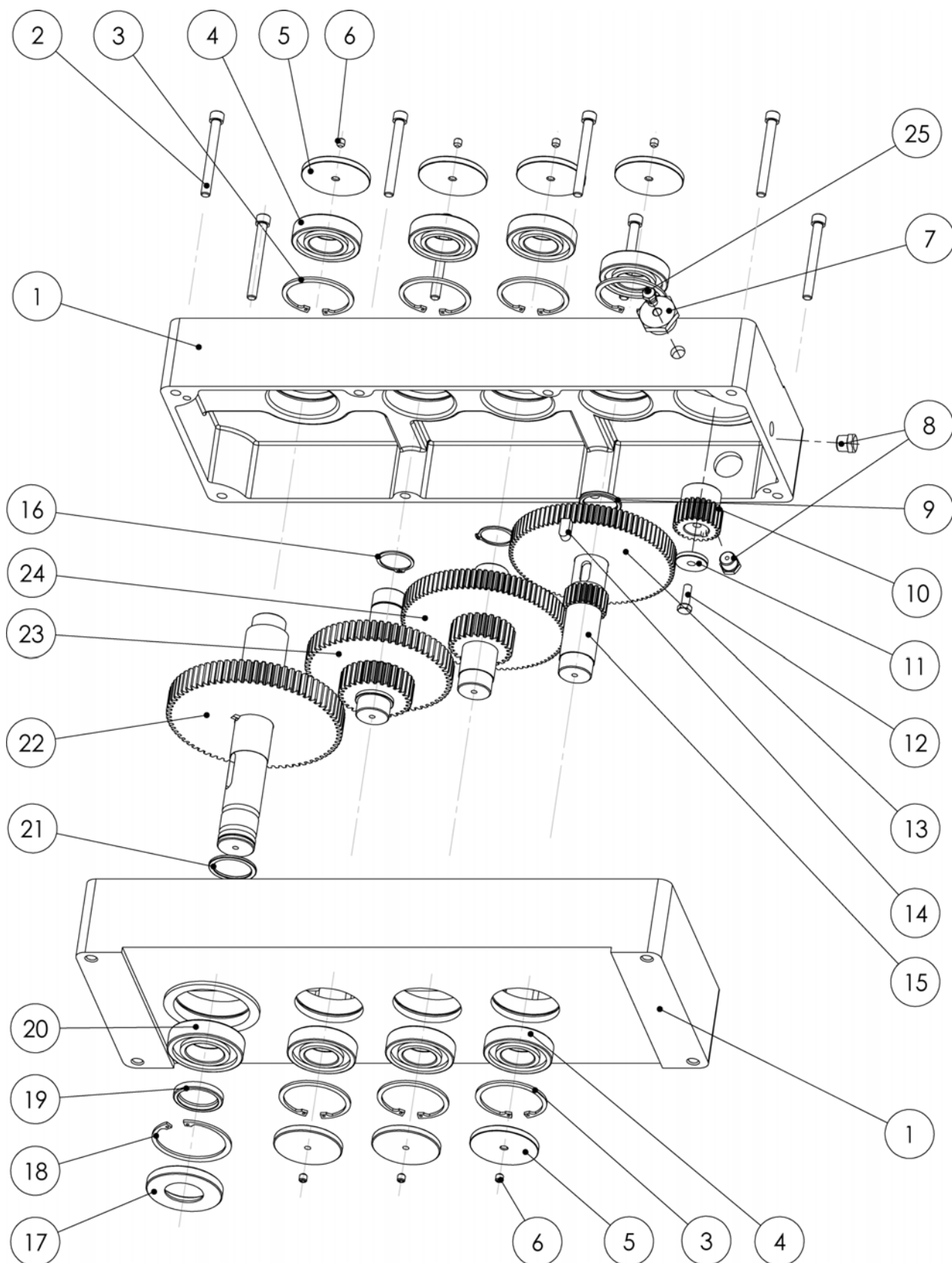

TECHNICAL DATA

- Oil type: SAE 90
- Oil volume: 7 litres

AKRON® GRAIN EXTRACTOR model E-180-TH ANGULAR GEARBOX E-180-TH			
ELEM. #	PART NUMBER	NAME	
1	20.43.09405	HELICAL GEAR WHEEL	2
2	20.43.09408	SPACER BUSHING	2
3	98.730.330840	BEARING NO. 30208	4
4	20.42.11514	SEALING WASHER	4
5	98.610.273940	SILICONE-TYPE SEAL (DBH-SAV 5300 OR EQUIV.)	4
6	20.43.09409	SEAL HOUSING	4
7	13.43.11051	3/8" BSPT PLUG	1
8	98.370.100972	1/8" BSP BREATHING VALVE	1
9	20.43.09407	OUTLET SHAFT	1
10	20.43.09411	10X10X24 KEY	2
11	20.39.09401	HOUSING	1
12	98.037.095076	RW 3/8" X 3" HEXAGONAL-SOCKET HEAD CAP SCREW	8
13	20.43.11608	1" BSPT HEXAGONAL-HEAD PLUG	1
14	20.43.09406	INLET SHAFT	1

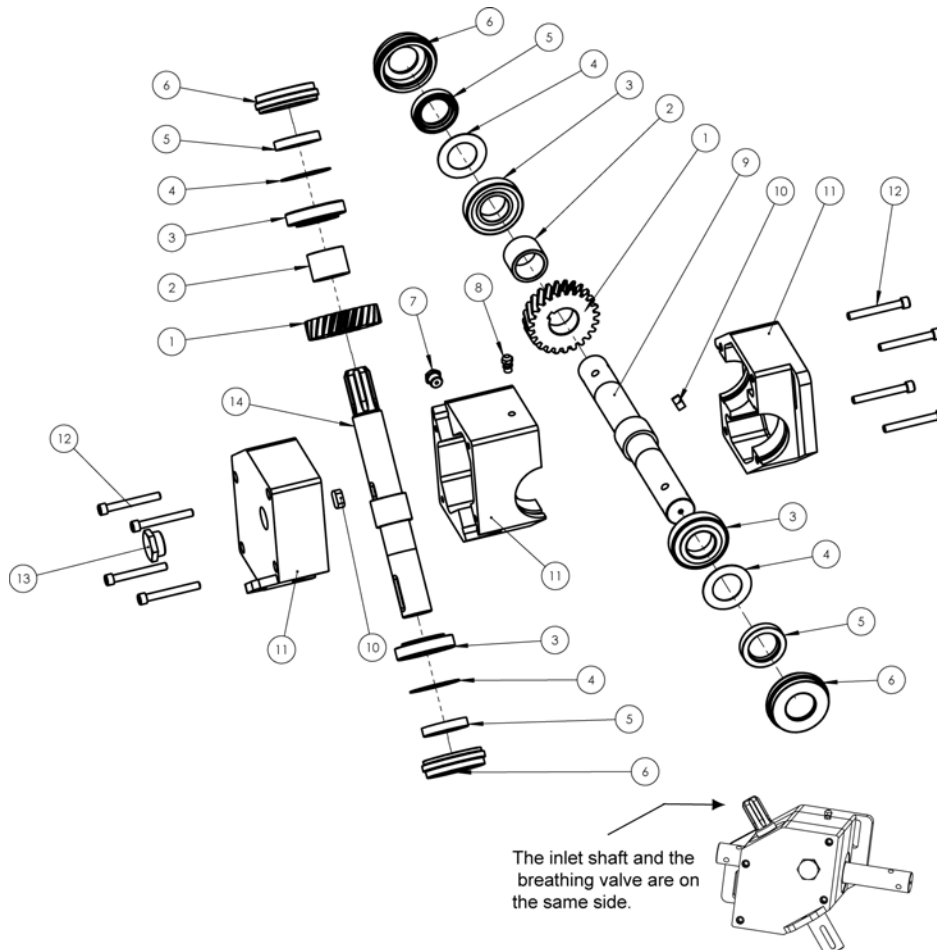

TECHNICAL DATA

- Oil type: SAE 90
- Oil volume: 2,5 litres

AKRON® GRAIN EXTRACTOR model E 180 TH SWITCH VALVE			
ELEM. #	PART NUMBER	NAME	QTY.
1	25.43.14751	VALVE BODY	1
2	25.43.14752	CENTRAL SWITCHING SHAFT	1
3	98.620.002119	2-119 O’RING	1
4	98.620.002122	2-122 O’RING	1
5	25.43.14754	LEVER	1
6	98.321.000280	RETAINING RING FOR Ø 28 SHAFT	2
7	25.43.14757	OPERATING LEVER LOCK SCREW	1
8	98.511.100090	Ø 9 X Ø 13 X 1.2 COPPER WASHER	1
9	98.161.080012	M 8 X 12 HEXAGONAL-SOCKET ROUND-HEAD SCREW	1
10	98.338.000063	1/4" STEEL BALL	1
11	98.329.060030	Ø 6 X 30 SPRING TENSION PIN	2
12	98.342.014758	SPRING: O.D. 6 – P 2.8 – L 18 – W.D. 0.8	1
13	98.675.014755	RW 5/16" HANDLE	1

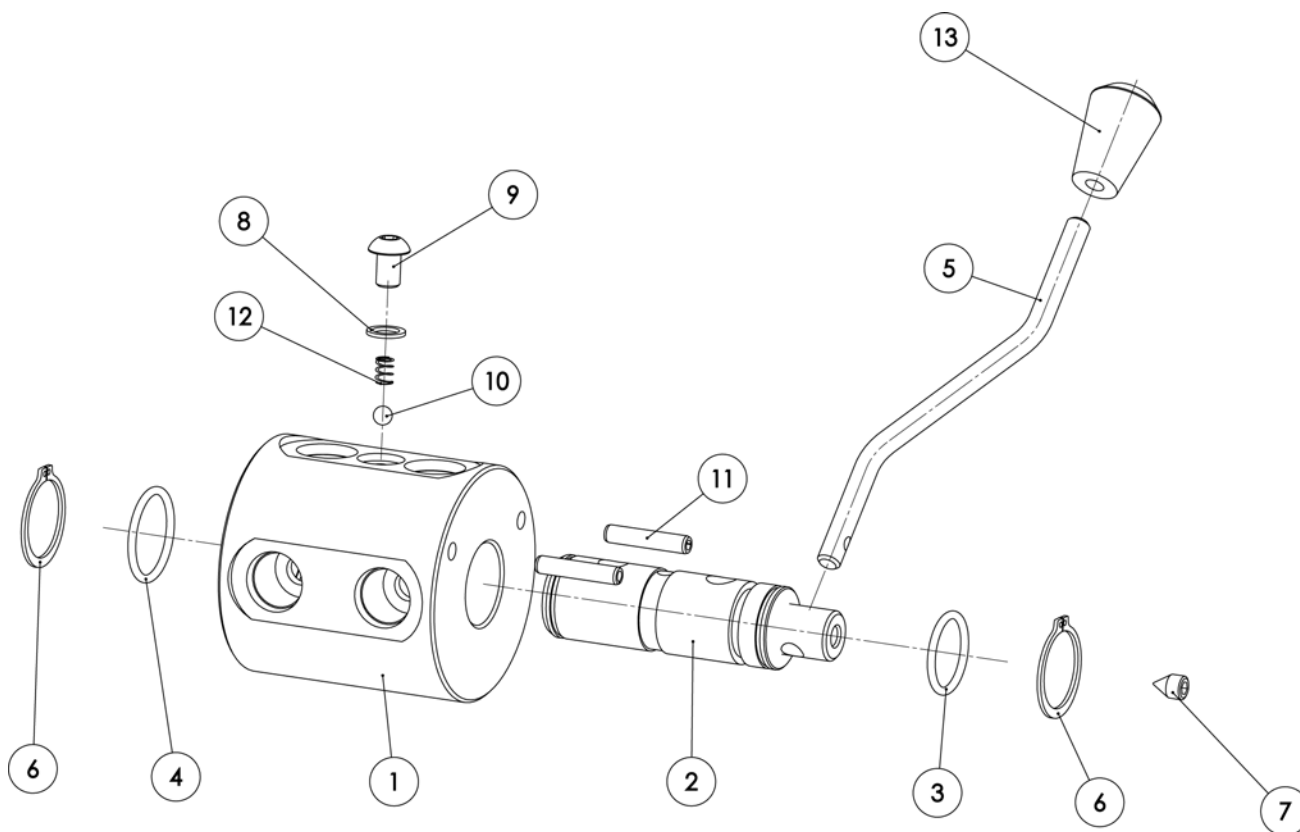

AKRON® Grain extractor model E 180 TH							
OPERATION OF THE HYDRAULIC RETRACTABLE SUPPORT, AUGER AND HYDRAULIC MOTOR							
ELEMENT #	PART NUMBER E180 TH 9"	PART NUMBER E180 TH 10"	NAME				QTY
			PIPE	LONG EXTEND	CURVES	JIC FERRULE NUTS	
1	98.378.082573	98.378.082573	3/8"	1728	3	2	1
2	98.378.082574	98.378.082574	3/8"	1640	1	2	2
3	98.378.082575	98.378.082575	3/8"	1728	3	2	1
4	98.378.082576	98.378.082576	3/8"	2020	3	2	1
5	98.378.082577	98.378.082577	3/8"	2020	1	2	1
6	98.378.082578	98.378.082578	3/8"	342	2	2	1
7	98.378.082579	98.378.082579	3/8"	236	1	2	1
8	98.378.082580	98.378.082580	3/8"	400	0	2	1
9	98.378.082581	98.378.082581	3/8"	513	4	1	1
10	98.378.082582	98.378.083582	3/8"	2437 (9') / 2837 (10')	3	1	1
11	98.378.082583	98.378.083583	3/8"	2400 (9') / 2800 (10')	1	2	1
#	E 180 TH 9"	E 180 TH 10"	ACCESORIES	NAME			QTY
12	98.378.071950	98.378.071950	T20-444-4-4-4	TEE M9/16 JIC X M9/16 JIC X M9/16 JIC			2
13	98.378.071951	98.378.071951	T20-454-4-4-4	TEE M9/16 JIC X HG 9/16 JIC X M9/16			2
14	98.378.071953	98.378.071953	T20-044-4-4-4	M9/16 JIC X M9/16 JIC ADAPTADOR			4
15	98.378.071954	98.378.071954	T40-014-8-4	M1/2 NPT X M9/16 JIC ADAPTADOR			2
16	98.378.071955	98.378.071955	T160 - 4-4	BRIDA SOPORTE CAÑO (NO INDICADO)			14
#	E 180 TH 9"	E 180 TH 10"	HOSE	TERMINAL	TERMINAL		QTY
17	98.378.083560	98.378.083560	SAE 100 R2 DIAM. INT. 1/4" L520	HG 9/16 JIC 37° Term. Prensable	H G 9/16 JIC 37° Term. Prensable		6
#	E 180 TH 9"	E 180 TH 10"	PIPE	LONG. EXTEND	CURVES	JIC FERRULE NUTS	QTY
18	98.378.082588	98.378.082588	1/2"	3015	6	2	1
19	98.378.082589	98.378.082589	1/2"	3092	6	2	1
20	98.378.082590	98.378.082590	1/2"	1324	5	2	1
21	98.378.082591	98.378.082591	1/2"	1108	4	2	1
22	98.378.082592	98.378.082592	1/2"	1038	4	2	1
23	98.378.082593	98.378.082593	1/2"	1080	4	2	1
24	98.378.082594	98.378.082594	1/2"	800	0	2	1
#	E 180 TH 9"	E 180 TH 10"	NAME				QTY
25	98.342.013132	98.342.013132	8 WAYS 4 POSITIONS SWITCH VALVE				1
26	98.378.071840	98.378.071840	TEE M 1 3/16" "O" X M3/4" JIC X M3/4" JIC				1
27	98.378.071845	98.378.071845	TEE M7/8" "O" PROL X 124 X M3/4" JIC X M3/4" JIC				1
28	98.378.071846	98.378.071846	TEE M 1 3/16" "O" X M 3/8" NPT X 3/4" JIC				1
29	98.378.056357	98.378.056357	CODO 90° HF 1/4" NPT X 3/4" JIC				1
30	98.378.060245	98.378.060245	M 1/2 NPT X m 3/4" JIC ADAPDOR				1
31	98.378.060136	98.378.060136	1.25 MM - 3/4" JIC X 1/4" NPT L: 70 PASSAGE				1
32	98.378.060135	98.378.060135	1.25 mm- 3/4" JIC X 1/4" NPT L:40 PASSAGE				1
33	98.378.065127	98.378.065127	3/4" JIC P/TUBO 1/2" NUT				2
34	98.378.066128	98.378.066128	1/2" JIC FERRULE				2
35	98.378.082620	98.378.082620	0-100 90340058 VENTURI BRAND FLOW CONTROL				1
36	27.43.80556	27.43.80556	VALVES BODY				1
37	70.43.13131	70.43.13131	SEAT SPRING				1
38	98.342.013132	98.342.013132	RETENTION VALVE FOR THE SPRING				1
39	98.338.000111	98.338.000111	7/16" STEEL BALL DIAM				1
40	98.620.002210	98.620.002210	O' RING 2-210				1
41	98.620.002214	98.620.002214	O' RING 2-214				2
42	98.378.080568	98.378.080568	100 CM3 HYDRAULIC MOTOR (NOT INDICATED)				1
43	98.378.83555	98.378.83555	HYDRAULIC RELIEF ASSEMBLY				1
44	98.378.083551	98.378.083551	27 KG PRESSURE RELIEF VALVE				1
45	98.378.071838	98.378.071838	TEE M - 3/8" NPT. M 3/4" JIC. M 3/4" JIC				1
46	98.378.071839	98.378.071839	TEE M3/8" NPT M3/4" JIC M3/4" JIC				1
47	98.378.060815	98.378.060815	M 3/4" JIC M - 1/2" BSP "O" FRONTAL ADAPTOR				1
48	98.378.060816	98.378.060816	HG 3/4" JIC _M1/2" BSP "O" "O" FRONTAL ADAPTOR				1
#	E 180 TH 9"	E 180 TH 10"	HOSE	TERMINAL	TERMINAL		QTY
49	98.378083554	98.378083554	SAE 100 R2 DIAM INT. 3/8" L 500	CODO 45° HG JIC 37° - 3/4" UNF 16 TERM. PRENSABLE	HG JIC 37° - 3/4" UNF 16 TERM PRENSABLE		1

<i>AKRON® Grain extractor model E 180 TH</i>							
OPERATION OF THE HYDRAULIC RETRACTABLE SUPPORT, AUGER AND HYDRAULIC MOTOR							
#	E 180 TH 9"	E 180 TH 10"	HOSE	TERMINAL	TERMINAL		QTY
50	98.378.083575	98.378.080575	SAE 100 R2 DIAM INT. 3/8" L 650	C 37°- 3/4" UNF 16 JIC ROTARY PIPE NUT	3/4" UNF -16 37° JIC MALE		2
51	98.378.083576	98.378.080576	SAE 100 R2 DIAM INT. 3/8" L 580	C 37°- 3/4" UNF 16 JIC ROTARY PIPE NUT	3/4" UNF -16 37° JIC MALE		2
52	98.378.083577	98.378.080577	SAE 100 R2 DIAM INT. 3/8" L 3000 ELBOW	NPT 1/2" 14 TAPER THREAD	NPT 1/2" 14 EN TAPER THREAD (not indicated)		1

LINE CIRCUIT FOR THE HYDRAULIC SUPPORT LEGS

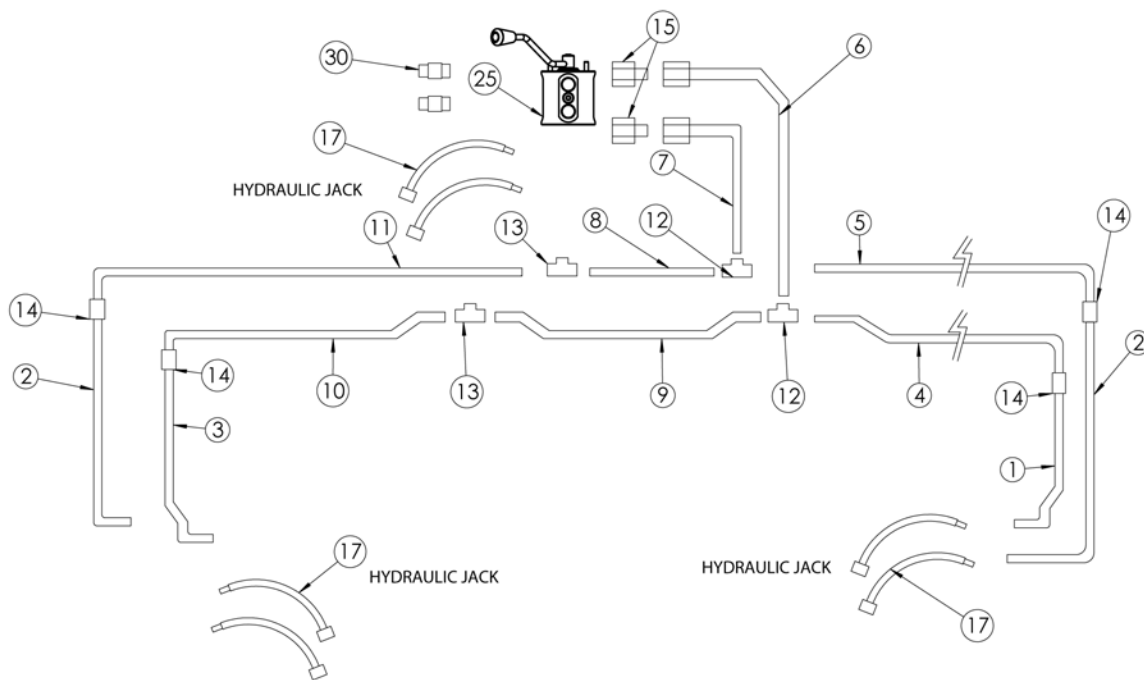

LINE CIRCUIT FOR THE HYDRAULIC MOTORS AND AUGER

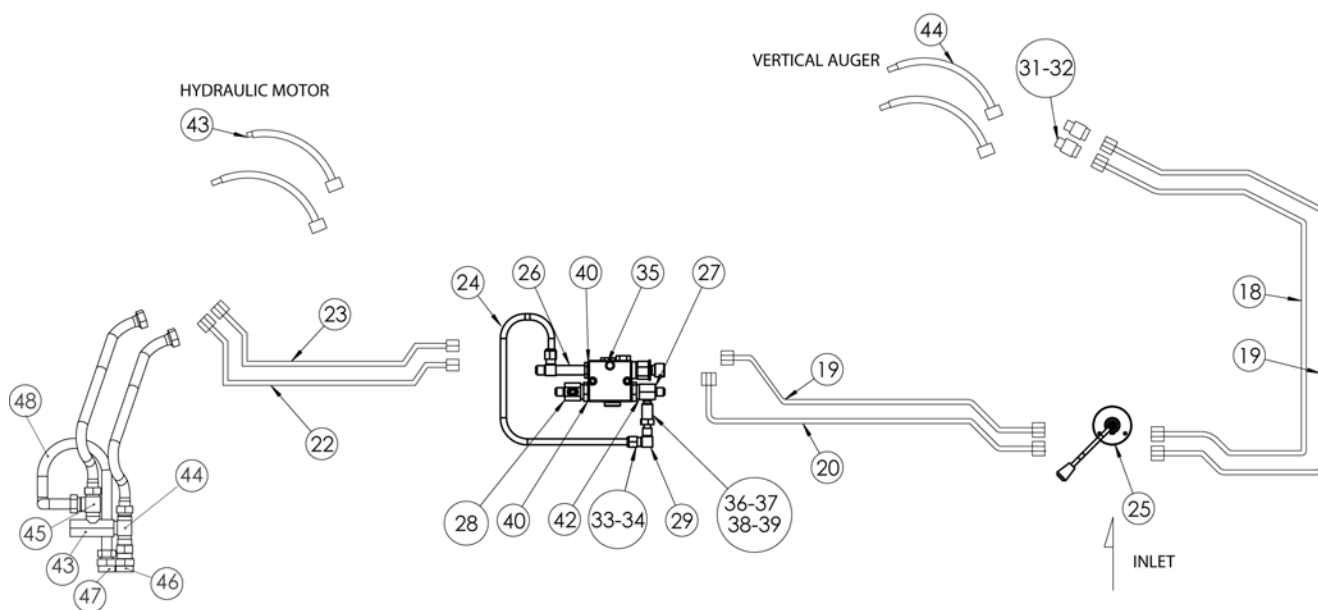

10. PARTS SUBJECT TO WEAR

Code	Article	Quantity
27.39.80425	Gearbox side- roll shaft end	1
27.43.80458	Vertical splined drive shaft (gearbox 98 to angular gearbox)	1
27.43.80453	Splined sleeve	2
Angular gearbox		
20.43.09405	Helical gear wheel	2
20.43.09406	Inlet shaft	1
Gearbox 98		
20.43.09805	Bevel gear wheel Z15 (inlet)	1
20.43.09806	Bevel gear wheel Z15 (outlet)	1
Reduction gearbox		
20.43.80004	Primary shaft with gear wheel Z21	1
20.39.80035	2 nd shaft assembly	1
20.39.80036	3 rd shaft assembly	1
20.43.80007	Splined outlet shaft	1
Augers		
27.39.80310	Primary vertical auger without heat treatment	1
27.39.82310	Case-hardened primary vertical auger	1
27.39.80311	Secondary vertical auger without heat treatment	1
27.39.82311	Case-hardened secondary vertical auger	1
27.39.80211	Left horizontal auger without heat treatment	1
27.39.82211	Case-hardened left horizontal auger	1
27.39.80210	Right horizontal auger without heat treatment	1
27.39.82210	Case-hardened right horizontal auger	1
27.39.80213	Extension without heat treatment for left horizontal auger	1
27.39.82213	Case-hardened extension for left horizontal auger	1
27.39.80212	Extension without heat treatment for right horizontal auger	1
27.39.82212	Case-hardened extension for right horizontal auger	1

11. User's Notes

A series of horizontal dotted lines provided for the user to write notes.

