

Product description
Air/oil Panel
AOP

DESCRIPTION

Bijur's high performance Air / Oil Lubricating system delivers high-efficiency lubrication and cooling for high-speed spindles and other surfaces requiring precise lubrication.

The advance design delivers precise amounts of lubricant and eliminates residual drift of "oil fog" or mist during operation.

The system utilises a specially designed Positive displacement Injector (PDI) with oil output to a close tolerance level down to 0.01cc/cycle. This permits exact oil volumes to be discharged into an air mixing valve, the controlled air and oil flows through clear plastic tubing to the critical lubrication points.

A small intermittent discharge from injectors flows along the inside wall of the tubing until it is fully extended over the full length of the tubing.

Air expansion at nozzle tip delivers controlled spray (not mist) to the lubrication point for optimum performance.

The air / oil system can deliver small or large air flows to the lubrication point and handles a wide range of oil viscosities.

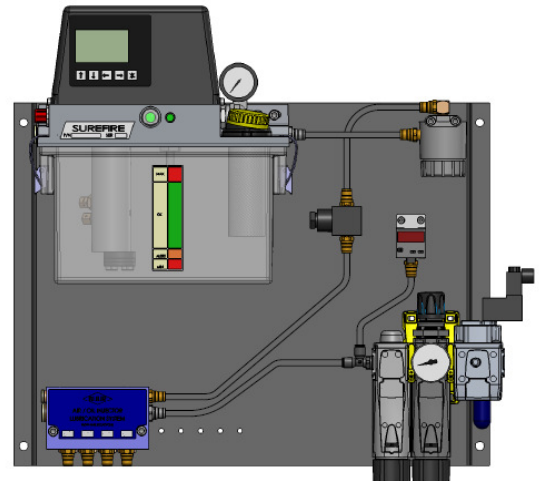

OPERATION

The electric 'Surefire' pump with or without the controller option provides adjustable pre-determined operation cycles which delivers oil into the air / oil block. The injectors in the air oil block then discharge a precise quantity of oil which is mixed with air in the air / oil block <Mixing Block>. The oil is then delivered in a continuous flow to the lubrication points. The air flow in each outlet can be individually adjusted to accommodate different lubrication requirements.

The air / oil panels come equipped with air and oil pressure switches, an air regulator system and all pumps are fitted with a oil low level switch.



TECHNICAL DATA

Reservoir Capacity :	1.8 L or 2.7 L
Oil operating pressure :	31 bars Max, 20 bar Min.
Air supply :	6 bar
Injector output:	0.01 ~ 0.40cc/cycle
Number of Injectors:	1 to 8
Oil filter :	5 microns
Operating viscosity:	20 to 1500cSt
Operating temperature :	5 to 40 °C
Level switch :	Current Switching Capacity 0.5amps at 240v
Oil pressure switch:	Current Switching Capacity 5 amps at 240v.
Air pressure switch :	0-10 Bars 12V-24VDC
Voltage	24 VDC, 115/230V AC, 50/60 Hz

For further information, reference our documentation on the Surefire Pump and the Air / Oil Block.



TYPICAL HIGH- SPEED SPINDLE INSTALLATION

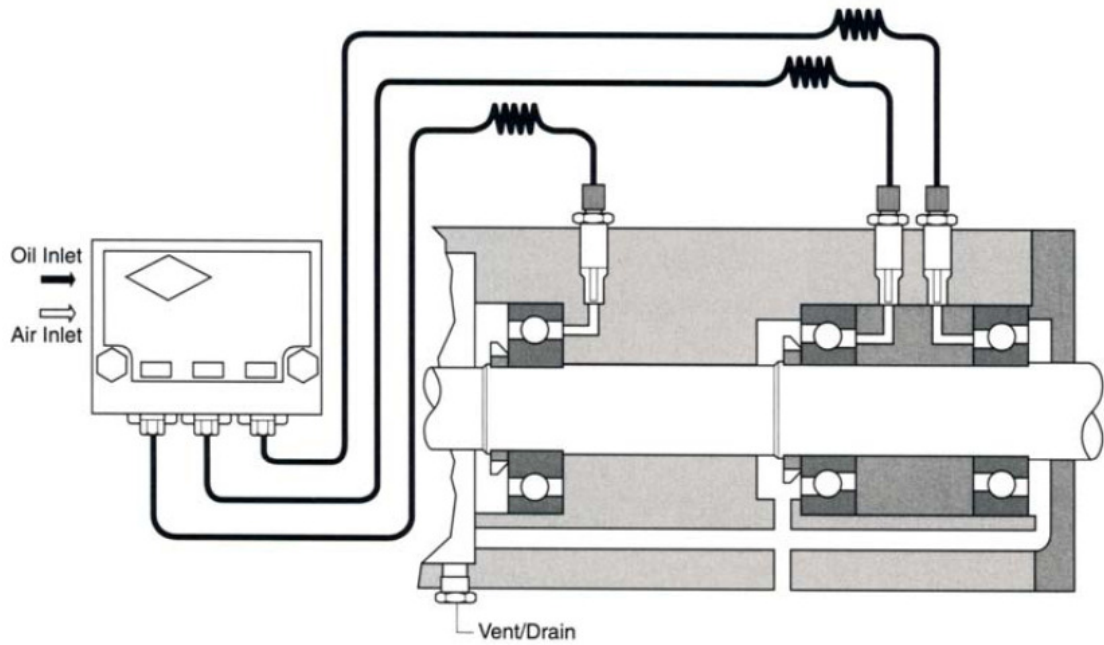

OIL FLOW IN THE TUBE

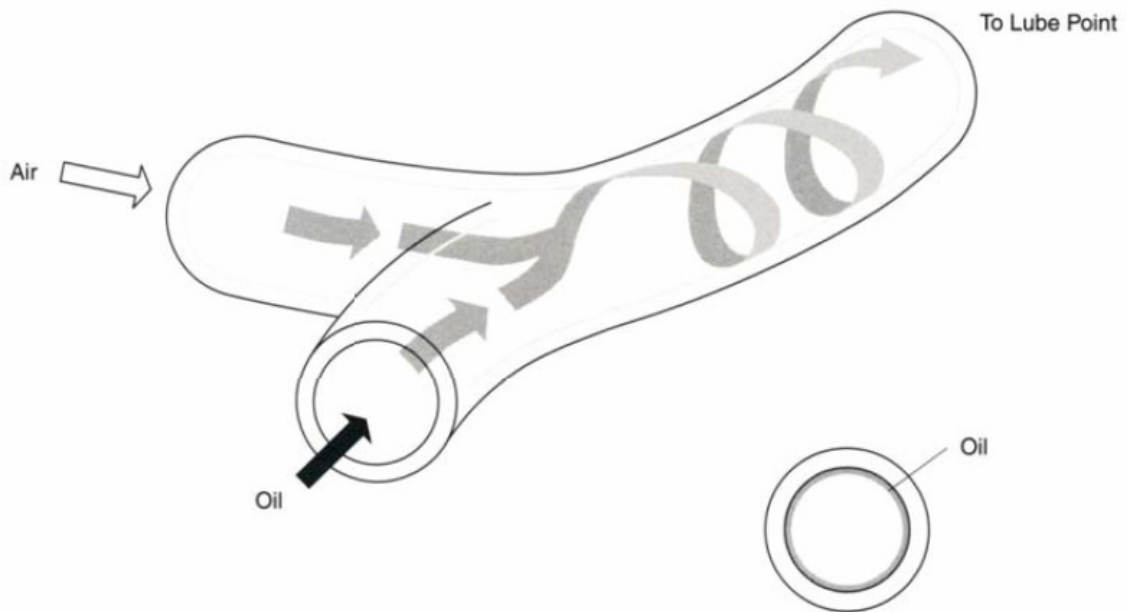

HOW TO ORDER

The Air / Oil Panel use a smart numbering system that allows you to tailor the panel to meet your needs.

A O P

Reservoir capacity

2	1,8 Liters plastic
3	2,7 Liters plastic

Options

A	No controller connection M 12 x 1
C	With controller connection M12 x 1

Voltage

B	24 V DC
C	115 V AC 50/60 Hz
D	230 V AC 50/60 Hz

Air care

A	Regulator
B	Regulator + filter 5 μ
C	Regulator + filter 5 μ + filter 0,01 μ
D	Regulator + filter 5 μ + filter 0,01 μ + valve 24 VDC

Example:

To order a panel which has the following options: SureFire 2.7L 230v AC with a controller, M12 x 1 and an Air Regulator + Filter 5 μ . The correct part number for this panel is **AOP 3 CDB**.

NB : The AIR/OIL block must be ordered separately.



CROSS SECTION OF AN AIR/OIL MIXING BLOCK

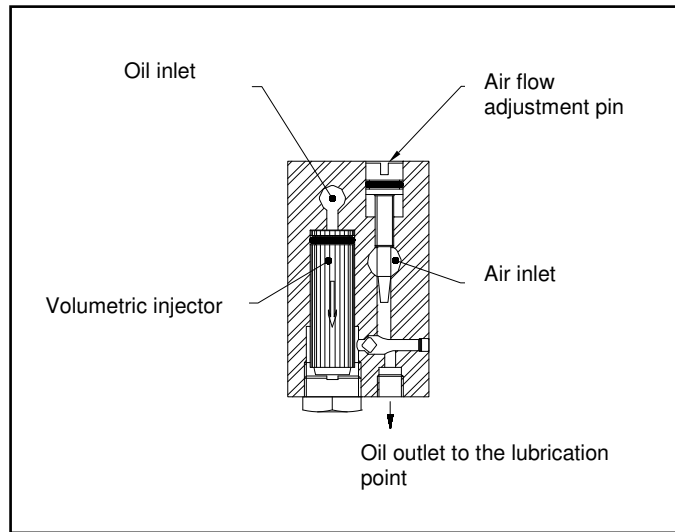

TUBING AVAILABLE

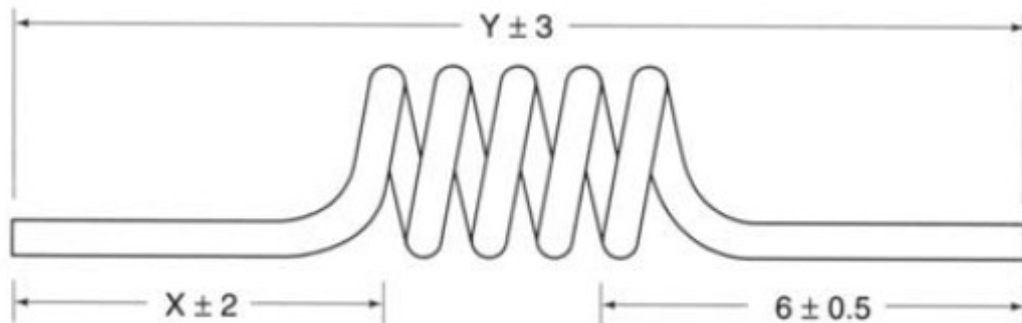

Tube Spiral			
Reference	No of spirals	X +/- 2 mm	Y +/- 3 mm
262632	2	25	31,5
262633	3	25	31,5
262634	4	25	31,5
262635	5	25	31,5



AIR / OIL PANEL SCHEMATIC

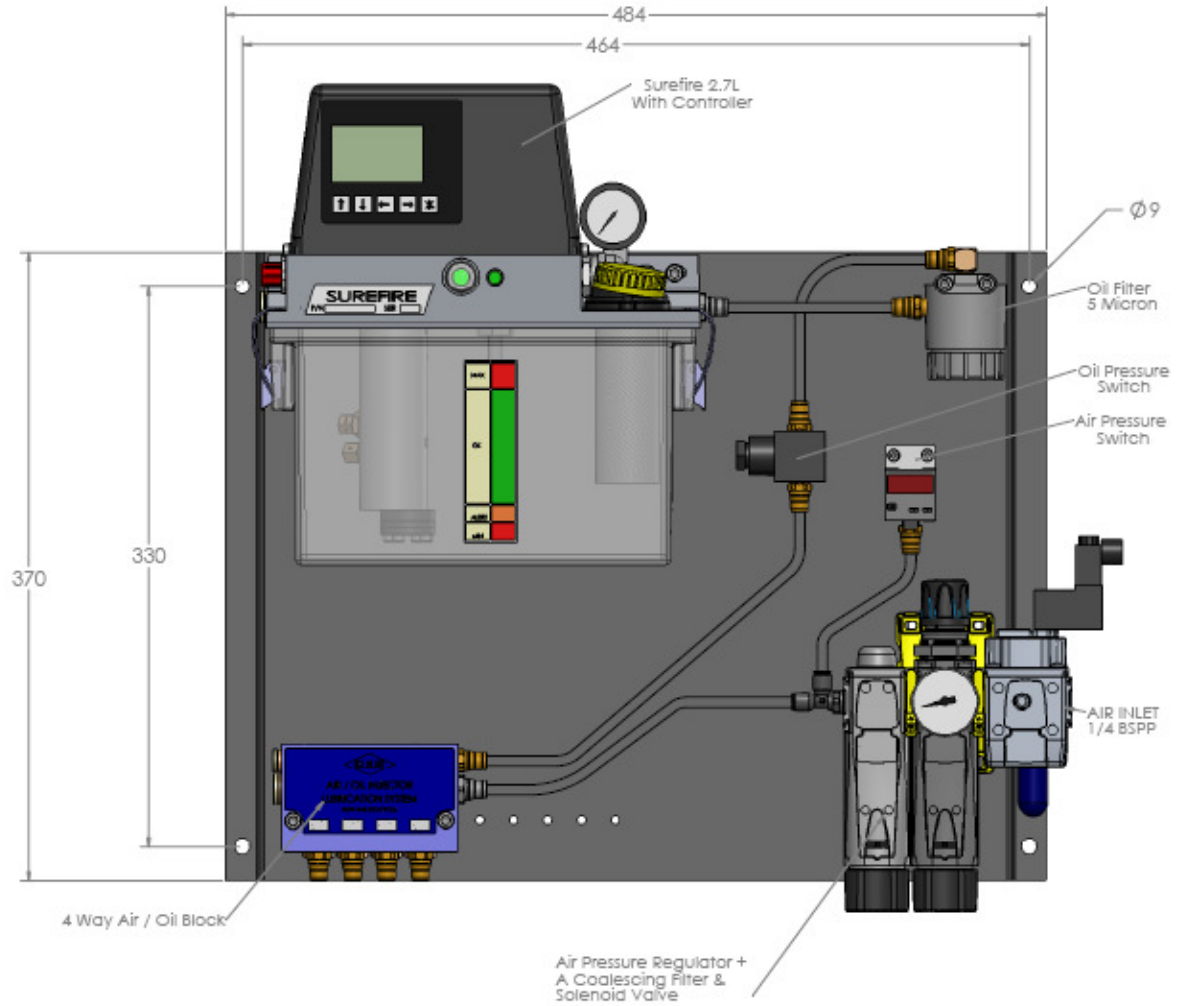

**Bijur Delimon
Germany**

Arminstraße 15
D-40227 Düsseldorf
Postfach 10 20 52
D-40011 Düsseldorf
Tel: (49) 211 7774 0
Fax : (49) 211 7774 210
info@delimon.de
www.bijurdelimon.com

&

Bijur Delimon
Niederlassung Beierfeld
Am Bockwald 4
D-08344 Grünhain-Beierfeld
Tel : (49) 377 475 65 11 0
Fax : +(49) 377 746511 0

**Bijur Delimon
Austria**

Am Spitz 2-3 / Schloßhofer Str. 4-6
Stiege 4, Top 20
A-1210 Vienna
Tel : (43) 1 585 66 17
Fax : (43) 1 585 66 17 50
info@delimon.at
www.delimon.at
www.bijurdelimon.com

**Bijur Delimon
Spain**

Avda. Txori-Erri 38
48150 Sondica - (Vizcaya)
Tel : (34) 94 453 20 00
Fax : (34) 94 453 25 00
www.bijurdelimon.com

**Bijur Delimon
United Kingdom**

Ramsden Court, Ramsden Road
Rotherwas Industrial Estate
Hereford
HR2 6LR
Tel : +44 (0) 1432 365 000
Fax : +44 (0) 1432 365 001
info@delimon.co.uk
www.bijurdelimon.com

**Bijur Delimon
USA**

2100 Gateway center
Blvd suite 109
Morrisville NC 27560
Tel : +1 919 465 44 48
Fax : +1 1 919 465 0516
www.bijurdelimon.com

**Bijur Delimon
France**

BP 50
ZI de Courtabœuf
5, Avenue de l'Atlantique
91942 Courtaboeuf Cedex
Tel : (33)1 692 985 85
Fax : (33) 1 690 776 27
contact@bijurdelimon.com
www.bijurdelimon.com

Bijur Delimon

No B-5 & 6, A Block, SNS Arcade,
Airport Road (HAL), BANGALORE
India
560010
Tel : (91 0)80 2522 1541 / 3959 / 652
mksantosh@bijurdelimon.in
www.bijurdelimon.com

**Bijur Delimon
Ireland**

Gort Road
Ennis, county Clare
Ireland
Tel : 353 65 682 1543
Fax : 353 65 682 0327
www.bijurdelimon.com

**Bijur Delimon
China**

9 Heng Tong Road
Nanjing Economical
And Technical
Development zone
2100038
Nanjing
Tel : +86 258 580 1188
Fax : +86 85802277
www.bijurdelimon.com

