

4-Port Antenna	R1	B1
Frequency Range	790-960	1710-2180
Dual Polarization	X	X
HPBW	65°	65°
Adjust. Electr. DT	0°-14°	0°-8°

set by hand or by optional RCU (Remote Control Unit)



4-Port Antenna 790-960/1710-2180 65°/65° 14.5/17.5dBi 0°-14°/0°-8°T

Type No.		742264v02		
Lowband		R1, connector 1-2		
		790-960		
Frequency Range	MHz	790 – 862	824 – 894	880 – 960
Gain at mid Tilt	dBi	14.1	14.2	14.3
Gain over all Tilts	dBi	14.1 ± 0.2	14.2 ± 0.3	14.3 ± 0.3
Horizontal Pattern:				
Azimuth Beamwidth	°	69 ± 1.1	68 ± 1.2	67 ± 1.4
Front-to-Back Ratio, Total Power, ± 30°	dB	> 25	> 26	> 28
Cross Polar Discrimination at Boresight	dB	> 24	> 26	> 26
Cross Polar Discrimination over Sector	dB	> 13.0	> 12.5	> 12.5
Azimuth Beam Port-to-Port Tracking	dB	< 1.0	< 1.0	< 1.5
Vertical Pattern:				
Elevation Beamwidth	°	16.7 ± 0.6	16.2 ± 0.9	15.4 ± 0.9
Electrical Downtilt continuously adjustable	°	0.0 – 14.0		
Tilt Accuracy	°	< 0.5	< 0.5	< 0.7
First Upper Side Lobe Suppression	dB	> 15	> 17	> 18
Cross Polar Isolation	dB	> 30		
Port to Port Isolation	dB	> 45 (R1 // B1)		
Max. Effective Power per Port	W	300 (at 50 °C ambient temperature)		
Max. Effective Power Port 1-2	W	600 (at 50 °C ambient temperature)		



Values based on NGMN-P-BASTA (version 9.6) requirements.

Highband		B1, connector 3-4		
			1710-2180	
Frequency Range	MHz	1710 – 1880	1850 – 1990	1920 – 2180
Gain at mid Tilt	dBi	17.3	17.5	17.5
Gain over all Tilts	dBi	17.2 ± 0.3	17.4 ± 0.2	17.4 ± 0.3
Horizontal Pattern:				
Azimuth Beamwidth	°	61 ± 2.1	59 ± 2.7	59 ± 2.9
Front-to-Back Ratio, Total Power, ± 30°	dB	> 29	> 28	> 26
Cross Polar Discrimination at Boresight	dB	> 27	> 27	> 28
Cross Polar Discrimination over Sector	dB	> 12.5	> 16.0	> 13.5
Azimuth Beam Port-to-Port Tracking	dB	< 1.0	< 0.5	< 1.0
Vertical Pattern:				
Elevation Beamwidth	°	7.4 ± 0.3	7.1 ± 0.4	6.8 ± 0.5
Electrical Downtilt continuously adjustable	°	0.0 – 8.0		
Tilt Accuracy	°	< 0.4	< 0.4	< 0.4
First Upper Side Lobe Suppression	dB	> 14	> 13	> 13
Cross Polar Isolation	dB	> 30		
Port to Port Isolation	dB	> 45 (R1 // B1)		
Max. Effective Power per Port	W	250 (at 50 °C ambient temperature)		
Max. Effective Power Port 3-4	W	500 (at 50 °C ambient temperature)		

Values based on NGMN-P-BASTA (version 9.6) requirements.

Electrical specifications, all systems		
Impedance	Ω	50
VSWR		< 1.5
Return Loss	dB	> 14
Interband Isolation	dB	> 45
Passive Intermodulation	dBc	< -150 (2 x 43 dBm carrier)
Polarization	$^\circ$	+45, -45
Max. Effective Power for the Antenna	W	900 (at 50 °C ambient temperature)

Values based on NGMN-P-BASTA (version 9.6) requirements.

Mechanical specifications		
Input	4 x 7-16 female long neck	
Connector Position	bottom	
Adjustment Mechanism	2x, Position bottom continuously adjustable	
Wind load (at Rated Wind Speed: 150 km/h)	N lbf	Frontal: 210 70 Maximal: 340 76
Max. Wind Velocity	km/h mph	200 124
Height / Width / Depth	mm inches	1334 / 261 / 146 52.5 / 10.3 / 5.7
Category of Mounting Hardware	M (Medium)	
Weight	kg lb	16.0 / 18.2 (clamps incl.) 35.3 / 40.1 (clamps incl.)
Packing Size	mm inches	1646 / 282 / 182 64.8 / 11.1 / 7.2
Scope of Supply	Panel and 2 units of clamps for 42–115 mm 1.7–4.5 inches diameter	

Accessories (order separately if required)

Type No.	Description	Remarks mm / inches	Weight approx. kg lb	Units per antenna
731651	1 clamp	Mast diameter: 28 – 60 1.1 – 2.4	0.8 1.8	2
85010002	1 clamp	Mast diameter: 110 – 220 4.3 – 8.7	2.7 6.0	2
85010003	1 clamp	Mast diameter: 210 – 380 8.3 – 15.0	4.8 10.6	2
737978	1 downtilt kit	Downtilt angle: 0° – 16°	2.3 5.1	1

Accessories (included in the scope of supply)

738546	1 clamp	Mast diameter: 42 – 115 1.7 – 4.5	1.1 2.4	2
--------	---------	-------------------------------------	-----------	---

For downtilt mounting use the clamps for an appropriate mast diameter together with the downtilt kit.
Wall mounting: No additional mounting kit needed.

Material:

Reflector screen: Weather-proof aluminum.

Fiberglass housing: It covers totally the internal antenna components. The special design reduces the sealing areas to a minimum and guarantees the best weather protection. Fiberglass material guarantees optimum performance with regards to stability, stiffness, UV resistance and painting. The color of the radome is light grey.

All screws and nuts: Stainless steel or hot-dip galvanized steel.

Grounding:

The metal parts of the antenna including the mounting and the inner conductors are DC grounded.

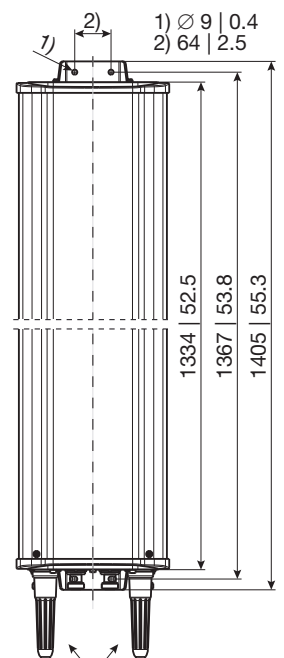

All dimensions in mm | inches

936.4895/b ngmn 04.19.01.00 Subject to alteration.

Layout of interface:

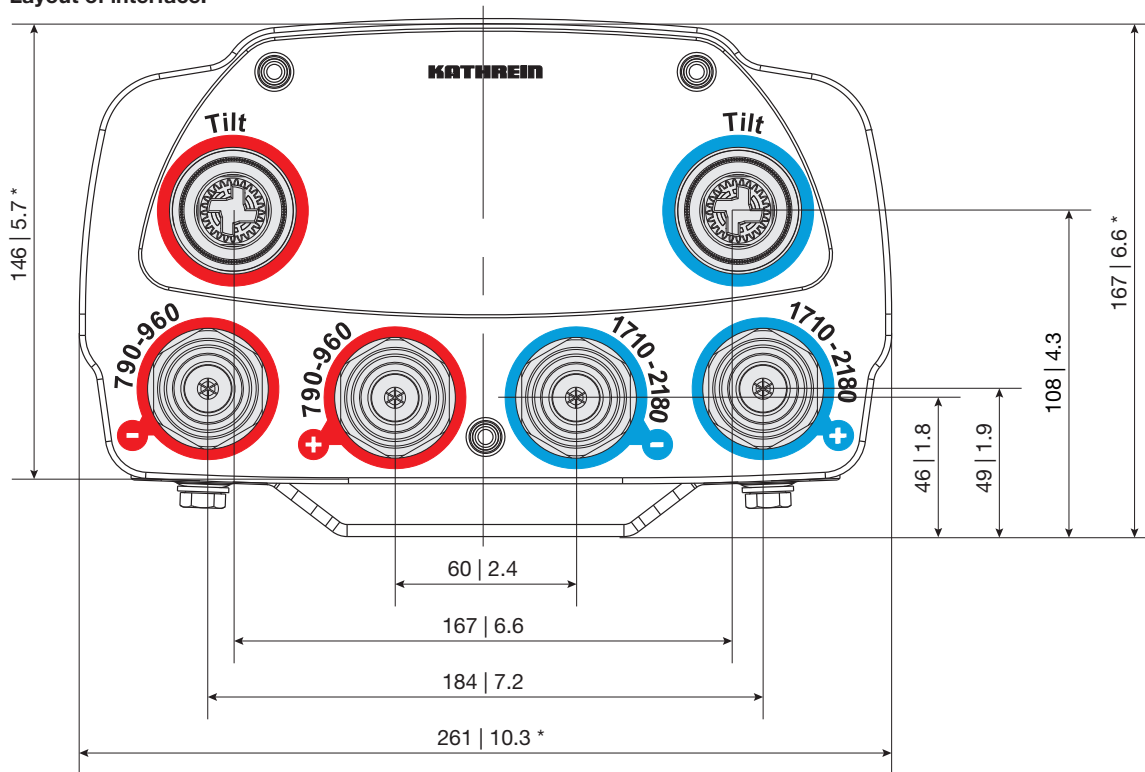

Bottom view
* Dimensions refer to radome
All dimensions in mm | inches

Correlation Table

Frequency range	Array	Connector
790- 960 MHz	R1	1-2
1710-2180 MHz	B1	3-4

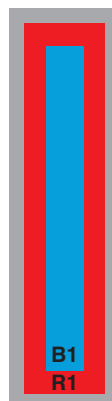

936.4895/b ngmn 04.19.01.00 Subject to alteration.

Any previous data sheet issues have now become invalid.

Mounting Hardware

Clamp Included in the Scope of Supply

KATHREIN

Suitable for mast diameter	(mm) [inches]	42 – 115 [1.65 – 4.53]
Antenna – mast distance	(mm) [inches]	20 – 25 [0.79 – 0.98]
Material of clamp and screws		Hot-dip galvanized steel / stainless steel
Weight	(kg) [lb]	1.1 [2.43]

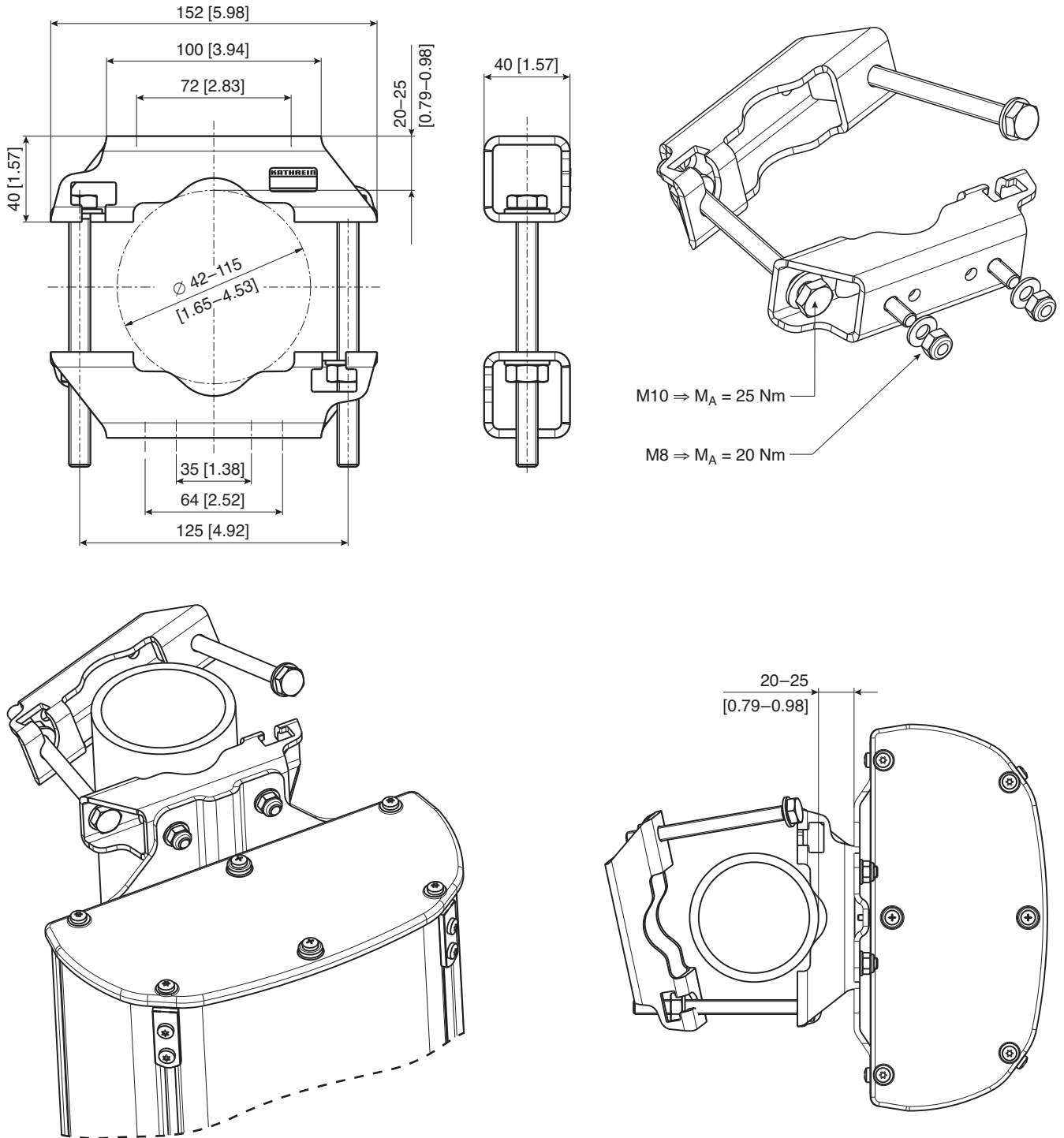

936.3920/c Subject to alteration.

**Please note: Kathrein does not recommend to use counter nuts.
The additional nuts supplied are only meant as spares.**

All dimensions in mm and [inches]

All specifications are subject to change without notice.
The latest specifications are available at www.kathreinusa.com

738546 Page 1 of 1

Description of the adjustment mechanism (protective cap removed):



- ① Twist protection.
- ② Downtilt spindle with integrated scale.



- ① Thread for fixing the protective cap or the RCU (Remote Control Unit).
- ② Gearwheel for RCU power drive.

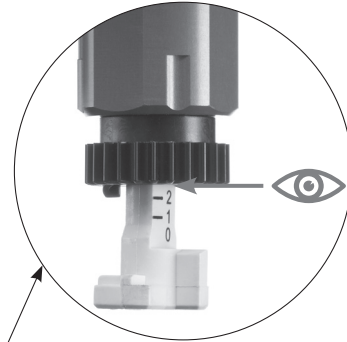

To set the downtilt angle exactly, you must look horizontally at the scale. The lower edge of the gearwheel must be used for alignment.

Manual adjustment procedure:

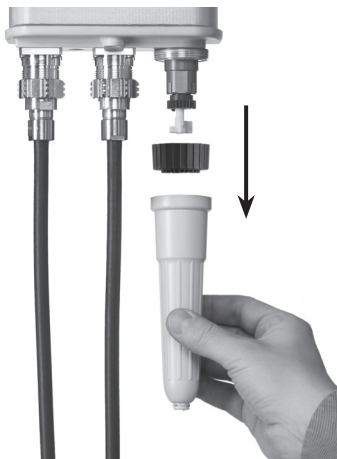

Remove the protective cap and the twist protection completely.

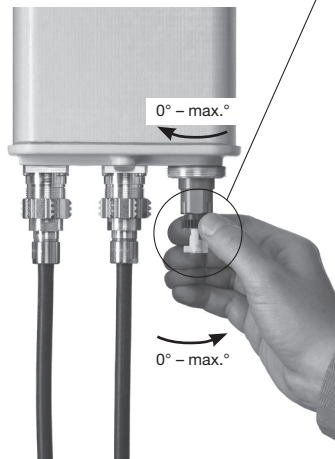

Set downtilt angle by rotating the gearwheel.

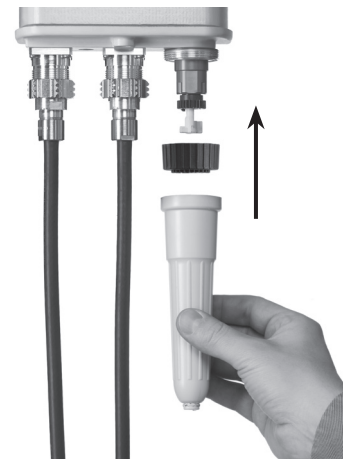

Screw on the twist protection and the protective cap again.

Optional: RCU (Remote Control Unit) for remote-controlled downtilt adjustment:

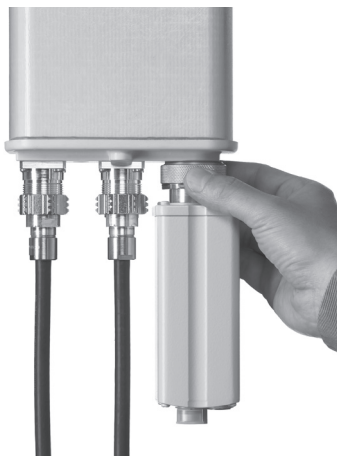

936.4037/a Subject to alteration.

For a description of RCU installation please refer to the respective data sheet.

General Instructions for Feederline and RCU Installation for Antennas

KATHREIN

Please note: In order not to damage the interfaces, please make sure that only the right tools are used. Tighten the feederline connector interfaces solely by using a common torque-wrench with a suitable wrench width.

Description of bottom end cap (exemplary picture):

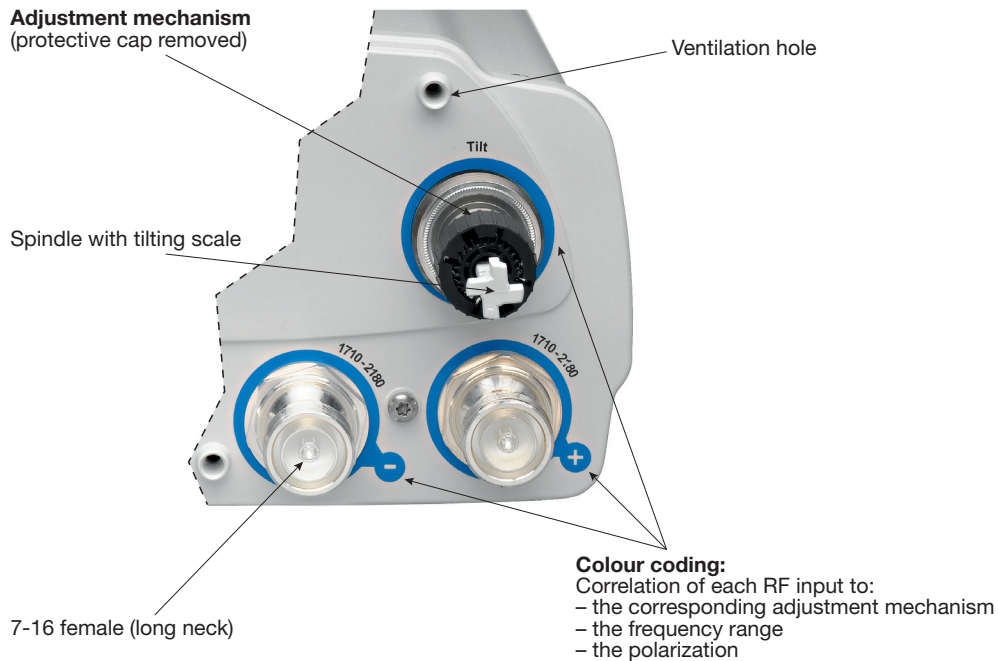

Installation of the feederline connector and RCU (optional):

In order to protect the adjustment mechanism, the protective caps have to be attached during feederline installation!



Carefully place the connector and fix the nut using a torque-wrench (according to the manufacturers guidelines).



After feederline installation, the optional remote control units (RCUs) can be mounted.

Kathrein installation set: Type No. 85010077 Set has to be ordered separately!

Set consists of three spanners of divers width 27, 32 and 41 mm | 1.1, 1.3 and 1.6 inches

1/2" square actuation according to DIN 3120 Form C

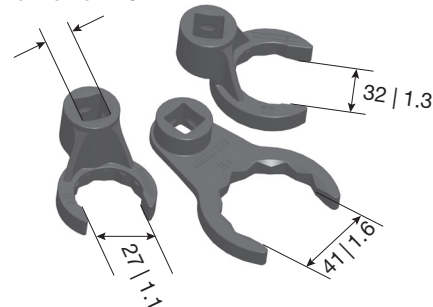

All dimensions in mm | inches

These tools are suitable for 7-16 connectors with a wrench size of 27 or 32 mm | 1.1 or 1.3 inches, and the RCU attachment nut with a wrench size of 41 mm | 1.6 inches.

Tighten nuts within a torque range of 25 – 33 Nm depending on connector manufacturers' specifications, respectively the RCU nut with a torque range of 15 – 18 Nm.