



306-360 HP

# MF BETA

7360/7370



FROM MASSEY FERGUSON





**Page 8**  
Head first feed - Choose your table

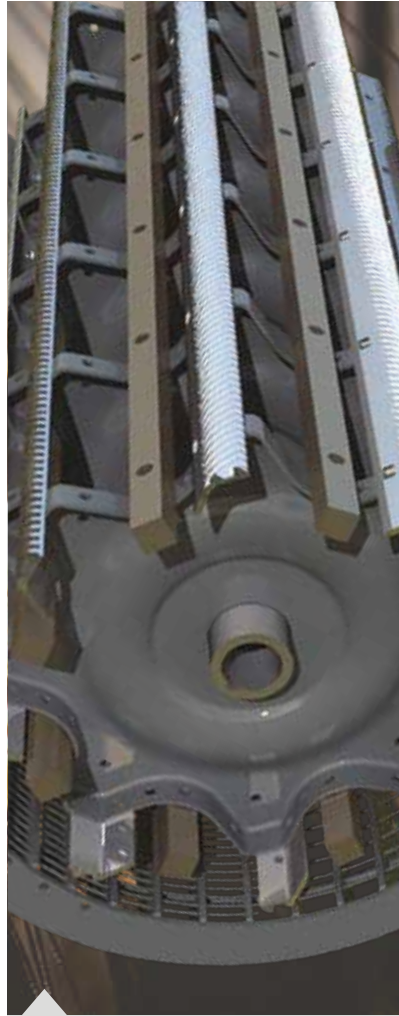

**Page 12**  
Threshing and separation



**Page 14**  
Results



**Page 20**  
Operator-friendly controls



**Page 22**  
Control from your fingertips

# Contents

- 04 Quality manufacturing
- 06 This is where it matters.
- 08 Head first feed - Choose your table
- 10 Pure Gold from Massey Ferguson
- 12 Threshing and separation
- 12 Two systems in one
- 13 A multitude of applications
- 14 Results
- 16 Make the most of your working day with a specially designed workplace.
- 18 My Space to work
- 20 Operator-friendly controls
- 22 Operation and control from your fingertips
- 24 Guidance and Precision farming
- 26 ParaLevel system
- 28 Good design makes for easy work
- 29 Time to harvest
- 30 How much importance do you place on your combine engine?
- 31 Parts. There when you need them.
- 32 Specifications
- 34 3D walkaround



## Page 30

How much importance do you place on your combine engine?

## Page 26

ParaLevel system







## Breganze, Italy

Harvesting Centre of Excellence for Massey Ferguson, Home of precision engineering and manufacture.

This is where each machine comes to life, where every tiny piece comes together to produce machines of incredible capabilities. The Breganze combine factory lies within the beautiful province of Vicenza in Italy. Like the various Massey Ferguson production plants around the world, the Breganze factory has an extensive and proud agricultural manufacturing history.

The Breganze factory manufactures mid-range, hybrid and 8-walker combine harvesters for Massey Ferguson, for distribution in Europe, Africa and the Middle East. This modern facility covers 25 Hectares and employs over 600 people. Produced using the latest technology, combine harvesters at the Breganze plant are built to the highest specification and quality by a very dedicated team.

Today Breganze produces combines with a range of threshing technologies. All combines are complemented by a range of FreeFlow or PowerFlow headers, available in different sizes, that are designed to maximise harvesting speed and efficiency while minimising crop loss.

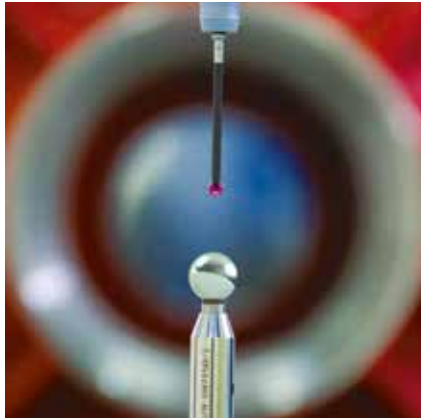
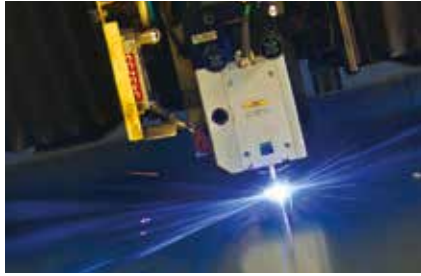



# MF BETA



# This is where it matters.

The MF Beta combine harvesters offer a straightforward, practical design with a mix of technology and functional features that are simple to work with in the field, where time is of the essence.

Model	Max power (hp/kW)	No. of straw walkers	Grain capacity (litres)
MF BETA 7360	306/225*	5	9000
MF BETA 7370	360/265*	6	9000
MF BETA 7360 ParaLevel (i)	306/225*	5	8600
MF BETA 7370 ParaLevel (i)	360/265*	6	8600

\*with Power Boost

- Premium quality operator environment with the Skyline cab designed for productivity
- Low operating costs, excellent fuel economy and simple servicing
- Quality sample from grain through to straw thanks to gentle threshing and intensive separation
- Flexible 2 in 1 threshing system for all crop capability with easy setting
- High capacity headers using quality materials designed to work in all conditions – PowerFlow or FreeFlow the professionals choice



# Head first feed

## Choose your table

Head first feed - start well, finish well - your header is critical to how well your combine performs - with a lifetime of experience, Massey Ferguson offers you a choice of its premium PowerFlow table or high capacity FreeFlow tables.



## FreeFlow up to 7.6 m



Combined multicoupler is standard for quick table dismount.



The Schumacher knife is the best performing knife in the business at 1220 cuts a minute. Self-cleaning and consistently sharp; this keeps the crop moving in tough conditions.



Full width auger fingers on the FreeFlow table increase auger throughput, ensuring positive and fast feed into the main crop elevator.



The Power Feed Roller at the front of the main crop elevator gives a consistent crop flow from the table into the main crop elevator. It can be reversed simply and effectively from the cab.





**TerraControl II** provides a mix of automatic functions for the standard table-levelling (**FreeFlow** or **PowerFlow**), ground-following system (Field pressure) and headland management – all the metrics are controlled from the operator's multifunction lever. Small changes in height requirement can be made quickly and easily creating an even feed in changing conditions. The automatic reel speed function takes tasks away from the operator so they can focus on getting the best from the machine.



## PowerFlow up to 7.7 m



The optional rape auger for the PowerFlow table increases the flow of tall crops into the elevator thereby increasing the output considerably. Two electrical side knives are available as options complete the Rape seed kit.



The knife is a massive 1.14m from the table auger so vision and performance are optimum. The rugged PowerFlow belts power the crop away from the knife and into the main crop elevator at a consistent speed. The belts also deflect stones rather than taking them into the machine where they might cause damage.



**PURE GOLD**





# FROM MASSEY FERGUSON

- thresh it gently and correctly and your profits increase



## Threshing and separation

The flexible heart of the combine. Equipped with a robust, high-inertia cylinder and a heavy-duty concave, these machines can handle crops easily.

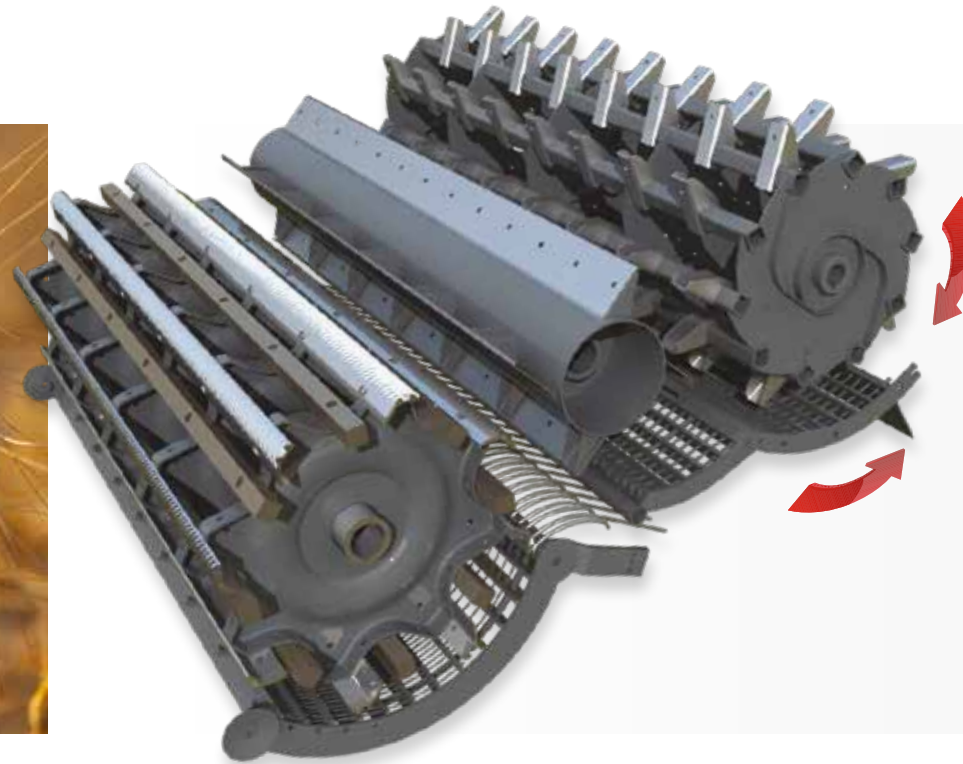

## Two systems in one

The Multicrop separator provides a massive separation area to remove as much of grain as possible before it reaches the walkers

The MCS (Multicrop Separator) has one unique feature that sets it apart from the rest, the ability to rotate the concave up over the top of the rotary separator when it is not required. The MCS concave is moved electrically, requiring no tools. This makes it possible to optimise machine performance in dry conditions reducing the load on the shaker shoes and considerably improving the straw quality.

The threshing drum has added weight in the form of ballast bars which increases the inertia in the cylinder as the rasp bars threshes the heads. This reduces load on the drives, power requirement and fuel consumption.

The concave has differentiated wire spacing, the rear section of the concave has half as many wires as the front section. This principle provides the optimum balance between high threshing capacity and good grain flow through the concave. The concave, front and rear, can be set from the cab independently in order to optimise the threshing quality.

At the rear the main concave is extended by the Active Beater Concave which is adjustable in three positions depending on conditions.



## A multitude of applications

A full maize kit can be fitted including a maize concave. For this application the chopper speed reduction kit comes as standard with the grain version.

To increase versatility and save time Massey Ferguson can offer an optional Sectional concave which is designed to harvest a multitude of crops. The conversion time when moving from small grain to large seeded crops such as Soya, Maize and Sunflower can be completed in minutes rather than hours.

Or a Universal concave with removable elements can be fitted if required.



A special Rice cylinder / concave version can be ordered with unique peg and tooth design, specifically for separation in tough conditions. Additional components are also fitted which have extra wearing capability. This includes the grain augers, elevators and the MCS teeth. These specifications coupled with self-lubricating tracks and tables specific with hard wear components provide a versatile machine for rice as well as grain and maize.

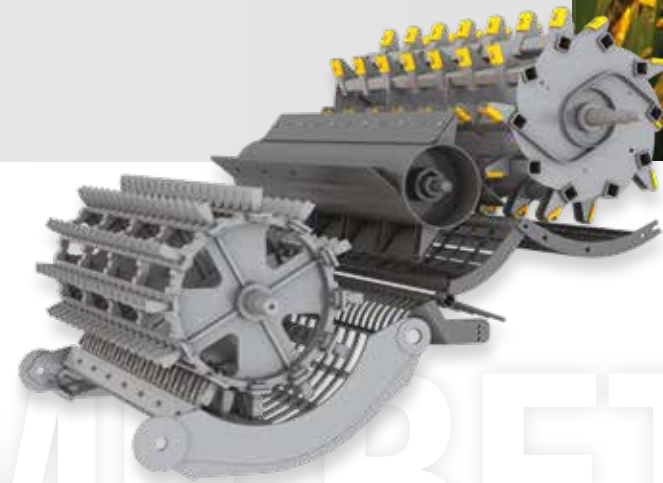

# MI BETA

# Results

The quality of your sample affects your margin. Special attention to the shaker shoe with the use of high capacity cleaning sieves gives you the best quality sample from the field. An optional yield monitor and moisture sensor with integral SD card can be fitted to allow measurement and traceability for the combine

The grain tanks have a high capacity (9000 litres on standard version and 8600 litres on the ParaLevel version) while the unloading rate of 105 l/sec is one of the highest in the class.



Electric Sieves operated from the cab enable easy attention to the sample, high sieve dividers give increased output on undulating land.



The long straw walkers feature four steps with 'active walls'. The 210 mm high, vertical sections of the walker steps are made up of permeable grids. These are the highest for any conventional combine. The front steps of the straw walkers are reinforced for maize harvestmaking the combine much more durable for variable crops



A simple returns sensor displays volume in the cab and enabling quick changes to improve the sample.





An adjustable dimple plate is standard to make sure straw is chopped consistently.



A twin rotor multi adjustable chaff spreader is available. Electrical deflectors for the straw chopper are available as an option. This allows the straw to be directed from the uncut crop if required.



For those that require straw, the threshing system is gentle and leaves the straw in perfect condition for baling feed and bedding straw or producing products for power generation.

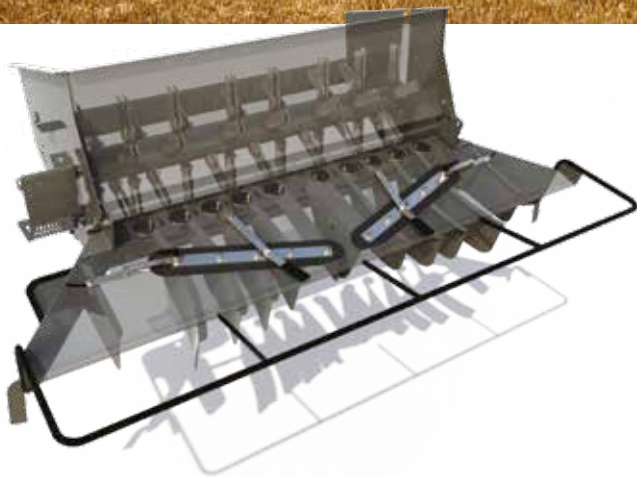

**The 6 row straw chopper** is specifically designed to give chopping and spreading performance suitable for farmers using reduced tillage operations. The knives are serrated to give a clean fine chop and reduce the power required. The fully adjustable stationary knives and straw chopper hood ensure complete control over the quality and spread of the chopped straw.

# WF BETA







**Make the most of your working day  
with a specially designed workplace.**

## **Working in the Skyline cab.**

A good cab environment is the key to getting the best performance from the machine and operator. Excellent visibility with ergonomically placed controls makes the workload easier and more productive. Intuitive menus on the TechTouch terminal provide information at a moments notice and active warning systems protect your investment.

# My Space to work

Fundamental elements of good cab design include space, comfort and visibility. The Skyline cab offers all of these; ensuring complete operator comfort at all times. Visibility is excellent with a panoramic view for the operator including header, stubble, unloader and at the rear with large electrically adjustable mirrors or the standard camera feature in the TechTouch terminal.

The cab comes with a host of features you would expect in an operator environment of this quality.

- Fully automatic air conditioning including heating
- Air suspension seat
- Electrically adjustable heated mirrors
- Instructor seat with cooler and storage box
- Excellent sound insulation including special sound absorbing glass means you work in quiet comfort
- Two part mirrors for selected visibility
- Safe and easy-to-use cab steps



View your stubble scenery



See the Unloader auger without having to bend forward



The TechTouch Terminal right at hand



Flexible visibility from the two part mirrors



Main controls from the operator's eye







# Get the best from your machine with operator-friendly controls



- 01 Reel lift / lower
- 02 Reel fore / aft
- 03 Automatic stop
- 04 Cutting header up/down
- 05 Cutting header level left/right
- 06 Unloading engagement
- 07 Unloading tube open/close/Auto
- 08 Guidance re-engagement
- 09 Automatic header control engagement

## Power grip lever

The new control interface for the operator falls naturally to hand - the PowerGrip Multifunction lever sits on top of the armrest which houses all the switches for the commonly used controls. The armrest can be raised and moved forward to suit the driver using two levers on the right hand side of the console.

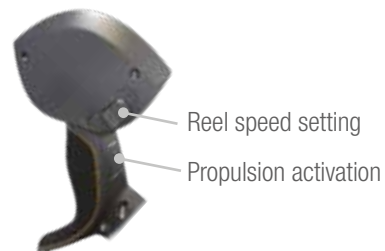

- 01 Engine speed setting
- 02 Thresher engagement
- 03 Cutting header engagement
- 04 4WD engagement (option)
- 05 Park brake engagement

## Power grip armrest

The right-hand armrest is the central operating unit where the key engagement switches sit with the throttle control. Designed with a large soft pad to cushion the arm during a long day allows for maximum comfort. As the propulsion lever does not need to slide it makes operation far more comfortable.



### Terminal

Perfectly in view and reach is the TechTouch terminal, providing all the relevant performance information and settings for the combine, touch screen controls with clear definition are easy to use and adjust.

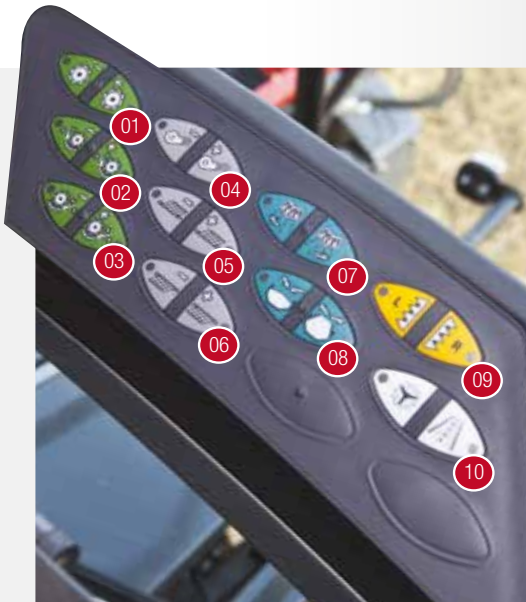

- 01 Drum speed setting
- 02 Front concave clearance
- 03 Rear concave clearance
- 04 Fan speed setting
- 05 Upper sieves setting
- 06 Lower sieves setting
- 07 Straw chopper deflector L/R, (optional)
- 08 Grain tank cover open/close
- 09 Vertical knives engagement
- 10 Road mode / Guidance engagement



### Keypad

The membrane keypad is located directly on the right side of the armrest and is used to operate the principle combine functions. The soft, raised keys lead directly to the individual menus on the TechTouch terminal.

# MF BETA

# Operation and control from your fingertips

The TechTouch Terminal is the control centre for all key performance operations, it has a touch screen or you can use the unique safety navigator to display the screen you require.



The **General information screen** is always on display in the top left hand side corner of the terminal. It shows engine speed and ground speed. Alongside these are the gauges for fuel, AdBlue, oil and engine temperature. The graphic also displays the current combine status for the grain tank and the unloader.



The easy to read displays on the **Combine main menu** indicate actual and set header height, grain loss from straw walkers and sieves and the returns volume. Below that current settings for header height, cylinder speed, concave opening front/rear, fan speed, sieve opening top/bottom. Through short cuts keys on the icons all settings can quickly be adjusted.



The windows at the bottom of the terminal are called **Info plus screens**. Here the operator can select between various screens giving detailed information on the combine functions. For example the operator see information at a glance on the engine and shaft speeds and be reassured that all systems are working fine.



Up to two **Camera views** can be seen in the terminal windows at the bottom. The operator can decide to have the camera view on display at all times or only for example, whilst reversing. The image can be enlarged to show the whole screen at the touch of a button, quickly and safely.



### Designed to make your life easy

- The large, easy-to-read screen is divided into four parts where the operator can choose what he wants to see. It really enables you to get the best from the settings – Its laid out in a logical way and is very easy to navigate with either the navigator pad or the short cut keys on the touch screen
- Clear colour display makes the job of interpreting the information very easy – warnings are shown clearly as a priority
- The mounting enables the operator to select the right position for him
- Automated crop settings – up to 10 variations of the crop settings can be made within the menu on the TechTouch terminal which when selected will alter the combine automatically
- A Standard Camera feature is integrated into the TechTouch terminal and gives enhanced visibility to the rear of the combine – A second camera is optional, the combine is pre-wired for this.



# Guidance and Precision farming

## Simple technology additions

Using the latest technology – the Auto-Guide™ xls option can steer you through to higher performance; optimising the field layout. Easily set from the terminal, Auto-Guide™ xls can offer accuracy down to 5cm or you can use an RTK signal if required. Automation leaves the operator to focus on getting the best from the whole machine. A button on the multifunction lever re-activates the system when turning on the headland.

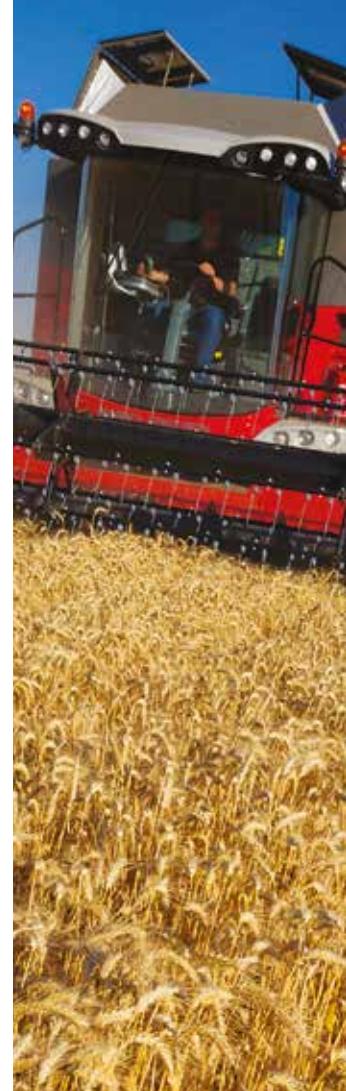
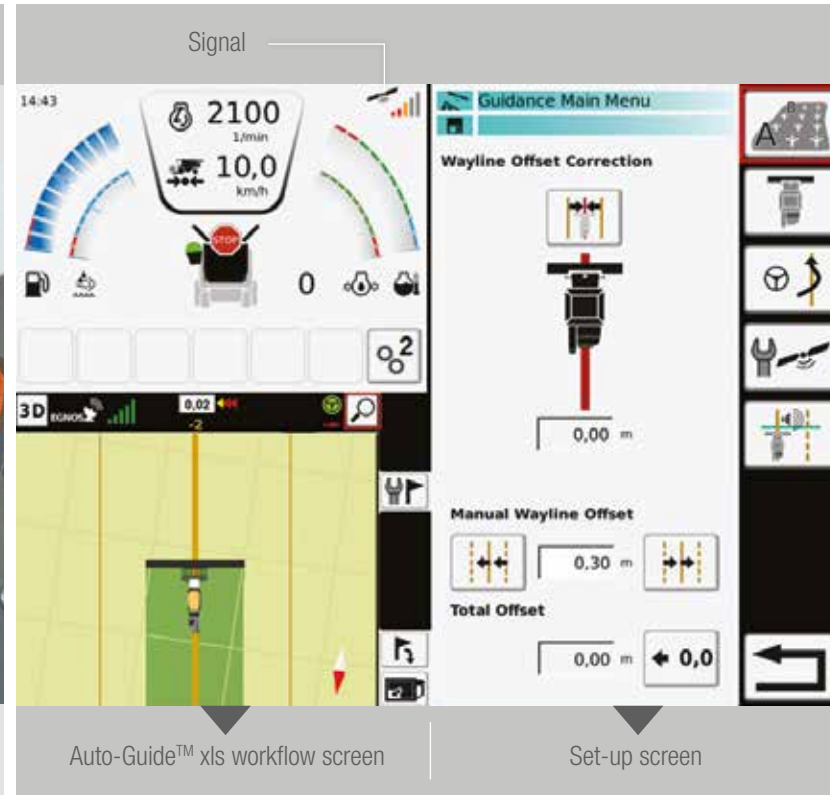





### Information logs

The terminal can provide performance information through the resettable trip counters gathering metrics such as area harvested, fuel used and time taken. Field names can be set up to make management simpler and allow the operator to collect data on the machines performance.

# AGCOMMAND

**AgCommand**® is the perfect fleet management and monitoring tool for large businesses, contractors or anybody who needs to keep a close eye on equipment out working – at all times. Part of the Fuse Technologies.

### On-the-go flexibility

Take all the benefits of **AgCommand**® to the field with the new **AgCommand**® app, for iPads and iPhones (also available on Android), allowing you to monitor machinery information, wherever you are and whenever you want. You can also use the history and efficiency report functions and analyse equipment in the field.

Operating data is collected automatically, transferred wirelessly and displayed in near real time on a secure webpage – there's no need to install any special software.

The app offers all the same functions as the desktop version including the same near real time access to the machine homepage that supplies information fast and a quick overview of machine data – position, address and weather.



# ParaLevel system

Advanced self-levelling design offering you total flexibility on inflexible terrain

Simple parallel linkage makes for effortless change of angle in the field. Both the MF 7360 and MF 7370 are available as a ParaLevel version, this patented system offers levelling with the table on slopes up to 20% (4WD). Combine components are generally designed to work on the level. This system maintains that level longer on slopes and therefore keeps the machine working at maximum efficiency for longer - increasing your output. Part of the package for balance is a **standard 4WD system** (2WD option), this gives more positive steering control and greater traction in all conditions, making it a safer place for your operator to work.



## MF Beta 7360 / 7370 PLi (Version)

For even more marginal land we can offer the MF Beta 7360/7370 PLi models which, as well as the ParaLevel system, offer an added capability with a special "Integrale" rear axle levelling feature. This enables each machine to level on slopes uphill to 30%.

It extends the efficiency of the combines on sloping ground, providing a better output and sample in complete safety for the operator. It works automatically and seamlessly ensuring the operator can concentrate on cutting accurately.



# Working on the level



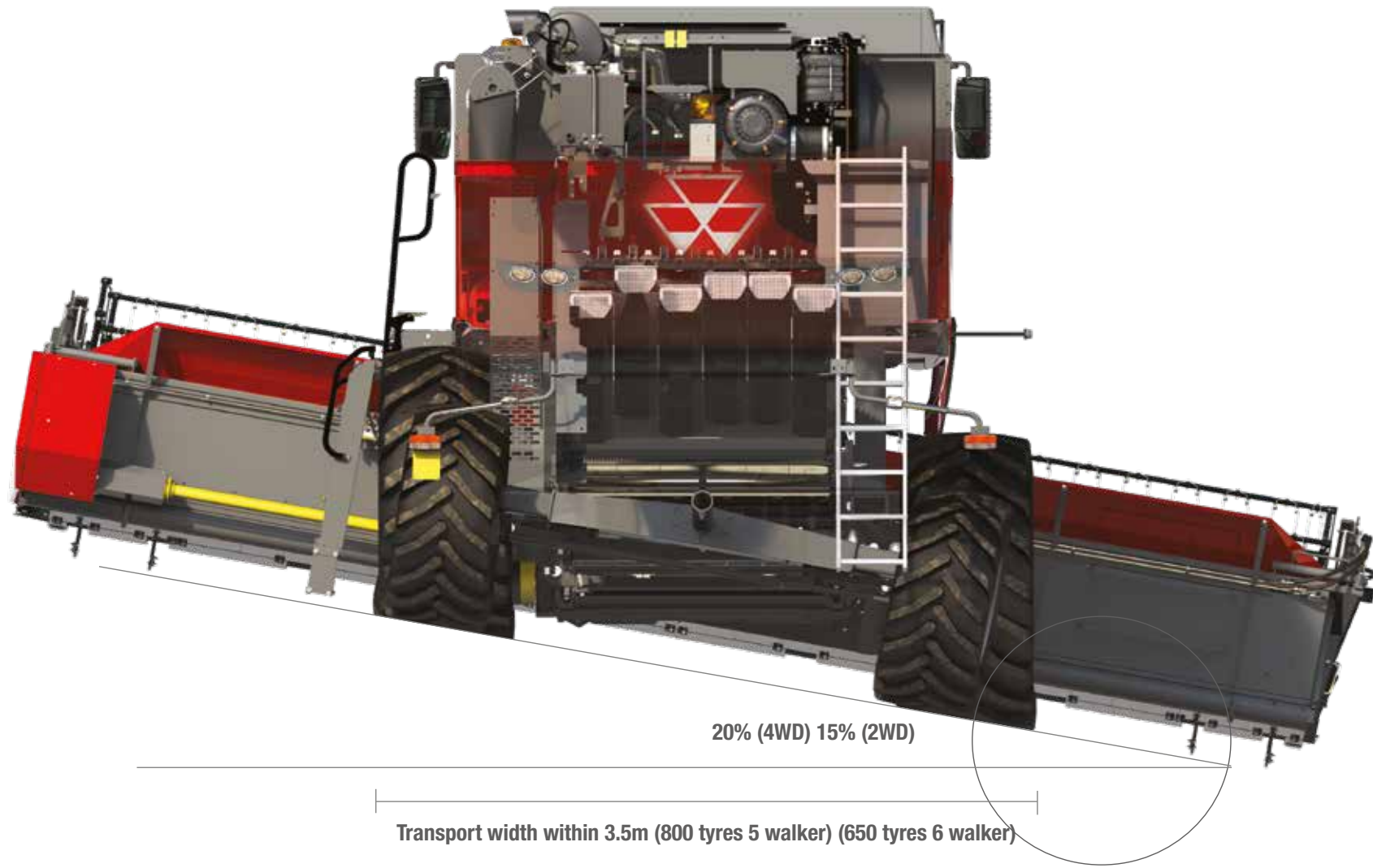

for more of the time

# Good design makes for easy work

Getting the best from well-designed features on a day-to-day basis.



Checking and cleaning the air filter



Safe and simple access for radiator cleaning



One piece panels with lights allow for quick inspection access



Easy refuelling - both tanks are located next to each other for easy access



Easy change from chopping to swathing for bales



Safe engine compartment and grain tank access with removable ladder



Easy access to new removable grain pan sections for quick and easy cleaning and service



# Time to harvest

Night working package includes H9 high intensity lights for all-round excellent visibility late into the evening.



## How much importance do you place on your combine engine?



We can promise you that your AGCO POWER engine has been designed to match the latest emission regulations using SCR technology meaning that actually it has one of the most advanced designs on the market. It's better for the environment and running costs will be one of the lowest in the business. These are important parameters.

Also it's important how it performs – we can tell you that the fuelling is designed to give a flat torque curve, one that a combine needs to give a constant delivery under load despite the conditions. This coupled with the low friction drives we use will give you incredibly low fuel consumption per tonne and excellent fuel economy.

(low regulation fuel versions available)

**We think it will make a significant difference to you!**



# MFservices

## Total Support from MF Services

Massey Ferguson and its Distributors and Dealers are always prepared and ready to put in the extra mile to support your purchase.



### AGCO's Harvest Promise

Our confidence in securing your harvest



Agriculture can be a tough business, that's why we make sure that you can get support whenever you need it and at crucial times of the year. Our Dealers are committed to finding the right product for you and then supporting you with the best service, parts provision and backup. You'll be part of a dedicated family of highly skilled specialists who make it their business to give you genuine, top quality service support.

We understand farming and are aware of the challenges each individual faces, therefore our Dealers can help you to plan for a successful future. Ask your Dealer about our finance plans, which can include leasing, hire purchase, contract hire and loan facilities.

You can also secure your assets with an **MFCare** Service and Extended Warranty Plan\*; a complete package aimed at providing total care for your combine including routine maintenance, repair cover and full AGCO backed warranty.

\*MFCare Service and Extended Warranty Plan may not be available or may be market dependant. Please contact your Massey Ferguson Dealer to check availability in your area. Terms and conditions apply.

AGCO's Harvest Promise is our commitment to you that, in the exceptional situation we can't get the parts to you in 48 hours, we will help you through our dealer network or even contribute towards a contractor to step in and harvest your crop until you're up and running again.\*

\*Terms & conditions apply. Only available in selected markets.

# Specifications as standard



<b>Table and main crop elevator</b>	
Cutting widths available on FreeFlow (m)	
Cutting widths available on PowerFlow (m)	
Table and elevator reverser	
Automatic reel speed	
TerraControl II Automatic Cutting height control	
Terracontrol II Autolevel table and Field pressure	
Power Feed roller	
<b>Hi-inertia cylinder</b>	
8 + 8 ballast bars	
Width / diameter (mm)	
Speed range (rev/min)	
<b>Concave</b>	
ABC concave (degrees)	
No. of bars	
Wrap angle (degrees)	
Area m <sup>2</sup>	
<b>Multi Crop Separator</b>	
Width / Diameter (mm)	
<b>Separator concave</b>	
No. of bars	
Area m <sup>2</sup>	
Rotating concave system	
<b>Straw walkers</b>	
No. / No. of steps	
Separation area m <sup>2</sup>	
<b>Shaker shoe</b>	
Grain pan with high dividers	
Top and bottom electrically adjustable sieves	
Total area m <sup>2</sup>	
Full width volumetric blade type fan	
Fan speed rev/min	
Returns to cylinder with monitoring	
Fan speed adjustment, electrical, in cab	
<b>Grain tank</b>	
Capacity (litres)	
Unloading rate (l/sec)	
Auger length (m)	
Unloading height (m)	

	<b>MF BETA 7360</b>	<b>MF BETA 7370</b>	<b>MF BETA 7360 PL (i)</b>	<b>MF BETA 7370 PL (i)</b>
Cutting widths available on FreeFlow (m)	4.80 to 7.60	4.80 to 7.60	4.80 to 7.60	4.80 to 7.60
Cutting widths available on PowerFlow (m)	5.50 to 6.80	5.50 to 7.60	5.50 to 6.80 (6.20)	5.50 to 6.80 (6.20)
Table and elevator reverser	●	●	●	●
Automatic reel speed	●	●	●	●
TerraControl II Automatic Cutting height control	●	●	●	●
Terracontrol II Autolevel table and Field pressure	●	●	●	●
Power Feed roller	●	●	●	●
Hi-inertia cylinder				
8 + 8 ballast bars	●	●	●	●
Width / diameter (mm)	1340 / 600	1600 / 600	1340 / 600	1600 / 600
Speed range (rev/min)	380 to 1100	430 to 1210	380 to 1100	430 to 1210
Concave				
ABC concave (degrees)	14	14	14	14
No. of bars	12	12	12	12
Wrap angle (degrees)	120	120	120	120
Area m <sup>2</sup>	0.83	0.99	0.83	0.99
Multi Crop Separator				
Width / Diameter (mm)	1340 / 600	1600 / 600	1340 / 600	1600 / 600
Separator concave				
No. of bars	8	8	8	8
Area m <sup>2</sup>	0.9	1.07	0.9	1.07
Rotating concave system	●	●	●	●
Straw walkers				
No. / No. of steps	5 / 4	6 / 4	5 / 4	6 / 4
Separation area m <sup>2</sup>	5.73	6.81	5.73	6.81
Shaker shoe				
Grain pan with high dividers	●	●	●	●
Top and bottom electrically adjustable sieves	●	●	●	●
Total area m <sup>2</sup>	4.67	5.58	4.67	5.58
Full width volumetric blade type fan	●	●	●	●
Fan speed rev/min	350 to 1050	350 to 1050	350 to 1050	350 to 1050
Returns to cylinder with monitoring	●	●	●	●
Fan speed adjustment, electrical, in cab	●	●	●	●
Grain tank				
Capacity (litres)	9000	9000	8600	8600
Unloading rate (l/sec)	105	105	105	105
Auger length (m)	5	5	5	5
Unloading height (m)	4.45	4.45	4.45	4.45

- Not available ● Standard specification ○ Optional



	MF BETA 7360	MF BETA 7370	MF BETA 7360 PL (i)	MF BETA 7370 PL (i)
<b>Residue handling</b>				
Six row straw chopper	•	•	•	•
Number of knives	72	88	72	88
<b>** Engine</b>				
AGCO Power Selective Catalytic Reduction (SCR)	•	•	•	•
Capacity (litres)	7.4	8.4	7.4	8.4
Power (ISO 14396) hp/kW *with Power Boost	276/203 - 306*/225	320/ 235 - 360*/265	276/203 - 306*/225	320 / 235 - 360*/265
Fuel tank capacity (litres)	620	620	620	620
AdBlue (litres)	80	80	80	80
<b>Transmission</b>				
Hydrostatic / 4 gears	•	•	•	•
<b>Tyres</b>				
Front	800/65 R 32	800/65 R 32	800/65 R 32	800/65 R 32
Rear	460/70 R 24	460/70 R 24	540/65 R 24	540/65 R 24
<b>Cab</b>				
Skyline	Heater, air conditioning, electrically controlled 2-part rear view mirrors, air suspended seat, 3D steering column, TechTouch Terminal, cooler box, rear view camera			
<b>Dimensions</b>				
Overall length without table (mm)	8910	9000	9100	9000
Width without table, standard tyres (mm)	3645	3900	3550	3870
Weight (kg)	13500	14000	14800 (15200) (i)	15300 (15700) (i)

\*\* (low regulation fuel versions available)

## Options

	MF BETA 7360	MF BETA 7370	MF BETA 7360 PL	MF BETA 7370 PL
ParaLevel Combine	-	-	○	○
2WD	-	-	○ (not PL i)	○ (not PL i)
<b>Residue handling</b>				
Straw chopper hood with electrical deflectors and mirror function	○	○	○	○
Chaff spreader	○	○	○	○
<b>Tyres (not PL i)</b>				
Front	650/75 R 32	650/75 R 32	650/75 R 32	650/75 R 32
Front	710/75 R 32	710/75 R 32	710/75 R 32	710/75 R 32
Below 3.5 m	800/65 R 32	650/75 R 32	800/65 R 32	650/75 R 32
<b>Tracks</b>				
ATRAK track system	-	○	-	-
High performance top sieve for maize	○	○	○	○
Fan speed reduction, 270 to 840 rev/min	○	○	○	○
<b>Accessories</b>	4WD rear axle (standard on ParaLevel version), multi media system with navigation, maize kit, air compressor, pea and bean kit, autoguidance, yield monitor, moisture sensor, LED working light pack.			

Every effort has been made to ensure that the information contained in this publication is as accurate and current as possible. However, inaccuracies, errors or omissions may occur and details of the specifications may be changed at any time without notice. Therefore, all specifications should be confirmed with your Massey Ferguson Dealer or Distributor prior to any purchase.

# Built to meet the demands of the toughest harvests

## Cab

Comfortable, spacious cab with TechTouch Terminal which is mounted to the drivers seat, for monitoring/adjustment of combine settings at the touch of a button.

## PowerFlow header

Active crop flow for continuous feed to the threshing cylinder in all conditions.

## Power Feed roller

Ensures continuous feed across the full width of the crop elevator for high outputs and excellent threshing quality.

## Threshing cylinder

High inertia threshing cylinder with ballast bars delivers high performance even in tough conditions.

## Grain Tank

Grain tank with electrically operated grain tank lids and high capacity for long runs in the field

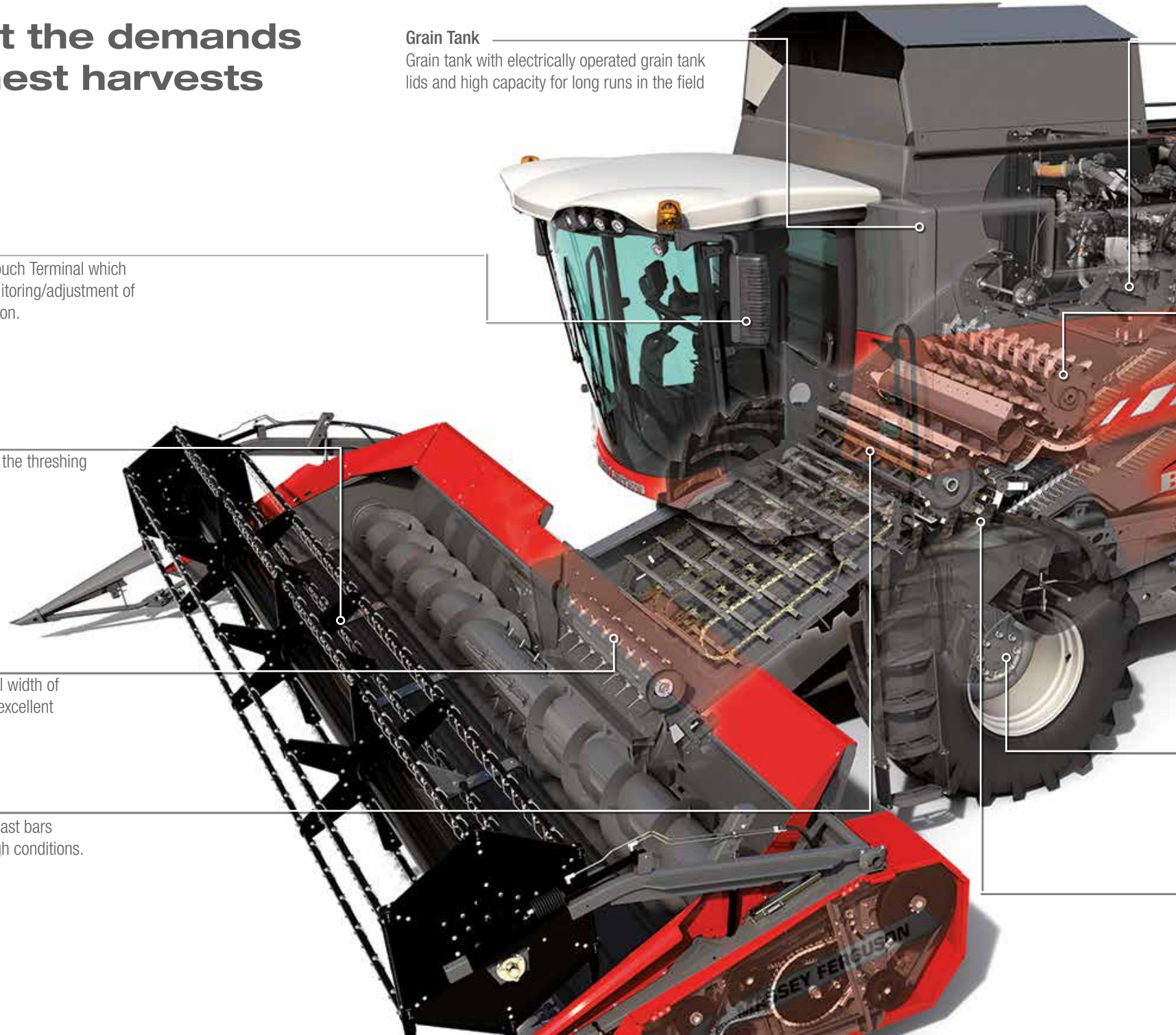





### **Engine**

Powerful AGCO Power 6-cylinder engine with SCR technology for excellent fuel efficiency and cleaner emissions.  
(low regulation fuel versions available)

### **Multi Crop Separator Plus**

Increased active grain separation in tough conditions. Uniquely the MCS Plus concave can be swivelled over the top to maintain good straw quality in dry conditions.

### **Straw walkers**

4.2 m long straw walkers with high and permeable straw walker steps for improved separation.

### **6 Row straw chopper**

Multi-adjustable serrated blade chopper for excellent chopping quality with low power requirement, giving an even spread of material over the entire table working width.

### **Shaker shoe**

Long grain pan with high dividers and 'High Capacity' sieves offer a very clean grain sample.

### **ParaLevel front axle (only on ParaLevel models)**

Unique and innovative combine levelling system for narrow transport width of 3.5m and combine levelling up to 20% (4WD) 15% (2WD).

### **Heavy-duty concave**

Independent front and rear setting of concave clearance facilitates optimal adjustment for best threshing results in any condition and crop (optional Sectional, Universal and Maize concave).



**MASSEY FERGUSON**

**A world of experience. Working with you.**



Web: [www.MasseyFerguson.com](http://www.MasseyFerguson.com)

Facebook: [www.Facebook.com/MasseyFergusonGlobal](http://www.Facebook.com/MasseyFergusonGlobal)

Twitter: [Twitter.com/MF\\_EAME](https://twitter.com/MF_EAME)

Instagram: [Instagram.com/MasseyFergusonGlobal](https://www.instagram.com/MasseyFergusonGlobal)

YouTube: [www.YouTube.com/MasseyFergusonGlobal](http://www.YouTube.com/MasseyFergusonGlobal)

Blog: [Blog.MasseyFerguson.com](http://Blog.MasseyFerguson.com)



Responsible forest management



MASSEY FERGUSON® is a worldwide brand of AGCO.  
© AGCO Limited. 2017 | A-A-16667/1117 | A-A-English/1117