

# 3. Chapter 3. AXIALLY LOADED MEMBERS

---

## 3.1. Reading Assignment:

Section 1.9 and Sections 8.1 and 8.2 of text.

Most axially loaded structural members carry some moment in addition to axial load - for this discussion, restrict consideration to axial load only.

---

## 3.2. Reinforcement of Compression Members

### 3.2.1. Plain concrete columns prohibited: possibility of bending is always present:

$$\text{ACI 10.9: } 0.01 \leq A_s/A_g \leq 0.08$$

ACI 10.9.1:

where  $A_s$  = Area of longitudinal reinforcement;

$A_g$  = Total area of column cross section;

### 3.2.2. Possible column configuration

a. Tied - Deformed bars or wires placed normal to column axis

Different tied arrangements ACI 7.10.5

Longitudinal  
Rods<sub>2</sub>  
and lateral ties

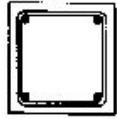

(a)

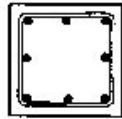

Spacing < 6"  
(b)

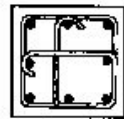

Spacing > 6"  
(c)

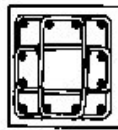

(d)

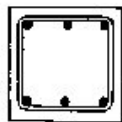

Spacing < 6"  
(e)

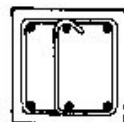

Spacing > 6"  
(f)

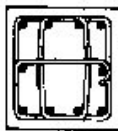

(g)

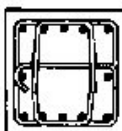

(h)

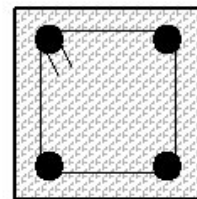
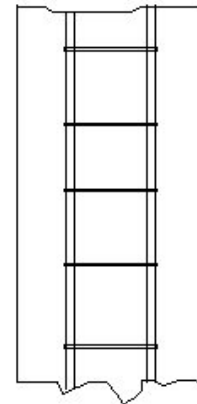

### 3.2.3. Spacing of Ties to Prevent Longitudinal Bar Buckling

- A. Tied column may fail prior to steel yield if shell spalls and longitudinal bars buckle;
- B. Insure that bar buckling load is greater than yield load. ( $\sigma_{cr} > f_y$ )

Assume that bar buckling load is greater than yield load - Assume a pin-pin bar between ties:

$$P_{cr} = \frac{\pi^2 EI}{L^2} \quad (3.1)$$

The moment of inertia of a circular bar is:

$$I = \frac{\pi D^4}{64} \quad (3.2)$$

and for  $\sigma_{cr} = P_{cr}/A = P_{cr}/(\pi D^2/4)$

$$\sigma_{cr} = \frac{\pi^2 E}{16(L/D)^2} \quad (3.3)$$

**Example:**

For  $f_y = 40 \text{ ksi} = \sigma_{cr}$

$$\sigma_{cr} = \frac{\pi^2 E}{16(L/D)^2} \rightarrow 40 = \frac{\pi E}{16(L/D)^2} \quad (3.4)$$

Solving for critical buckling condition

$$L = 21 D$$

So, to prevent buckling, space ties more closely than this.

ACI Code requires (ACI, Sect 7.10.5.2) that spacing not to be greater than

- 16 D (D = Diameter of longitudinal bar);
- 48 tie bar diameter;
- Least member dimension.

Other Code requirements are given in ACI Sections 7.10.5.

**b. Spiral:**

Circular arrangement of longitudinal bars confined by a continuous wire which spirals around the bars for the entire length of the member;

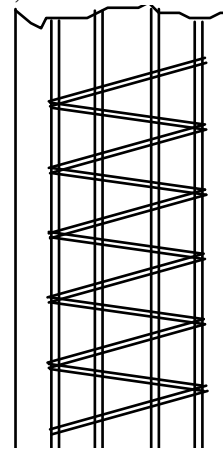
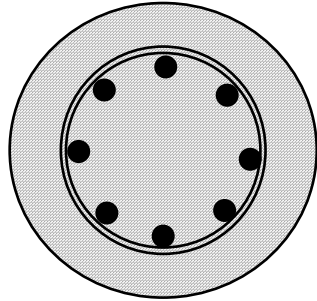

Longitudinal Rods  
and spiral hooping

**c. Composite and combination:**

Structural steel member encased in concrete or steel pipe filled with concrete

**ACI 10.9.2:**

- at least 4 bars in tied columns
- at least 6 bars in spiral columns
- at least 3 bars in triangular ties

**Note.-** Tied or spiral columns are used in order:

- to prevent buckling of longitudinal bars
- to prevent movement of longitudinal bars during construction.

Bundles of steel bars are sometimes used to prevent congestion. It is shown that they act as a unit with area as the same as all of the bundle bars.

In buildings columns generally have proportions with the ratio of length to cross section width ( $L/h$ ) in the range from about 8 to 12. (use of high strength, more slender column becoming more popular.)

---

### 3.3. Design Assumptions:

- A. Strain compatibility between steel and concrete (to perfect bonding; no slip; mechanical interlocking).

- B. Axially loaded only.- Uniform strain over cross section;  
 Axial load plus moment.-Strains vary linearly;  
 Moment only.- Strains vary linearly.
- Concrete tensile strength usually zero.
  - The internal forces must be in equilibrium with applied external loads.
  - Plane cross section remains plane after application of loading.
  - Theory is based on real strain-stress relationships.

Elastic behavior of column – Example (See ACI section 10.2)

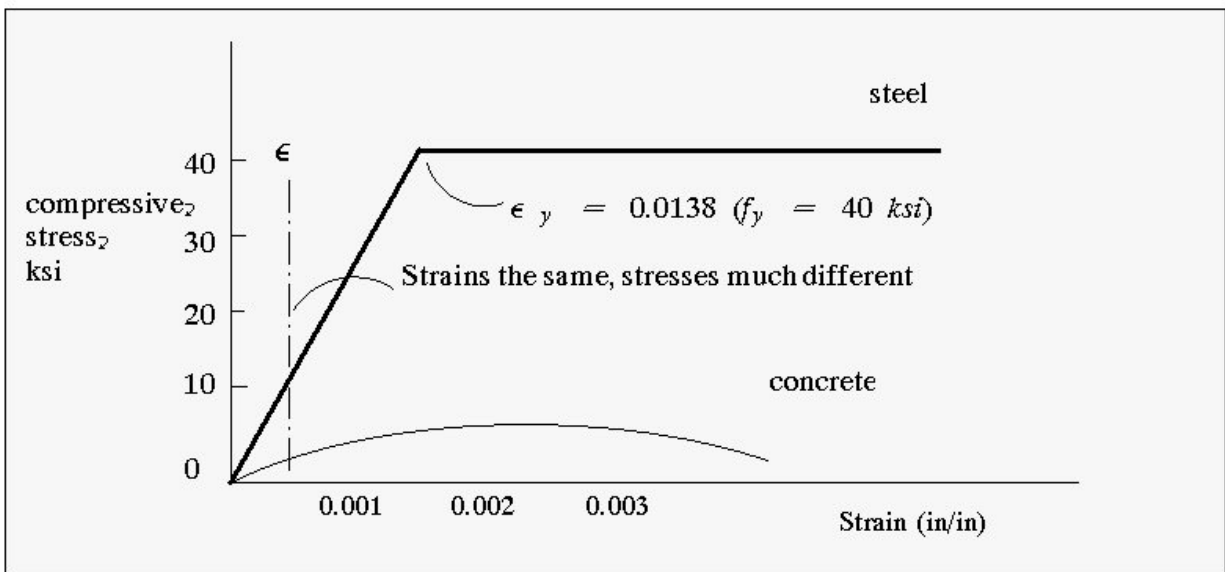

- Up to  $f_c \approx \frac{1}{2} f'_c$  concrete stress-strain approximately linear. This is known as the “working” or “service load” range:
- For strain equality in this range:

$$\epsilon = \epsilon_c = \epsilon_s = \frac{f_c}{E_c} = \frac{f_s}{E_s} \quad \text{or} \quad f_s = \frac{E_s}{E_c} f_c \quad (3.5)$$

letting

$$f_s = n f_c$$

Note: “n” is generally rounded to the nearest whole no.

Adopting the following notation:

$A_g$  = gross section area, (in<sup>2</sup>)

$A_s$  = area of steel (in<sup>2</sup>)

$A_c$  = net concrete area =  $A_g - A_s$

$P$  = Axial force on column

Then

$$P = A_c f_c + A_s f_s = A_c f_c + n f_c A_s = f_c (A_c + n A_s)$$

Transformed area

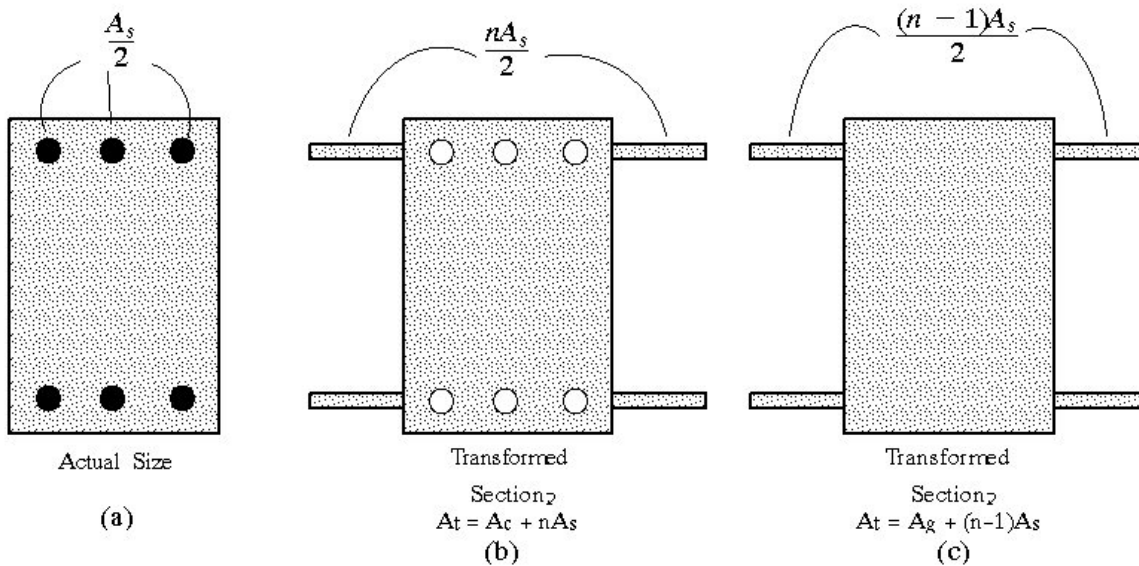

Transformed section in axial compression

The three bars along each of the two faces are thought of as being removed and replaced, at the same distance from the axis of the section, with added areas of fictitious concrete of total amount of  $nA_s$ . Alternatively, as shown in figure c, we can think of the area of the steel bars as replaced with concrete in which case one has to add to the gross concrete area  $A_g$  so obtained only  $(n-1)A_s$  in order to obtain the same total transformed area.

So, knowing  $A_c = A_g - A_s$

$$P = f_c (A_g + (n-1)A_s)$$

### 3.3.1. Example 1

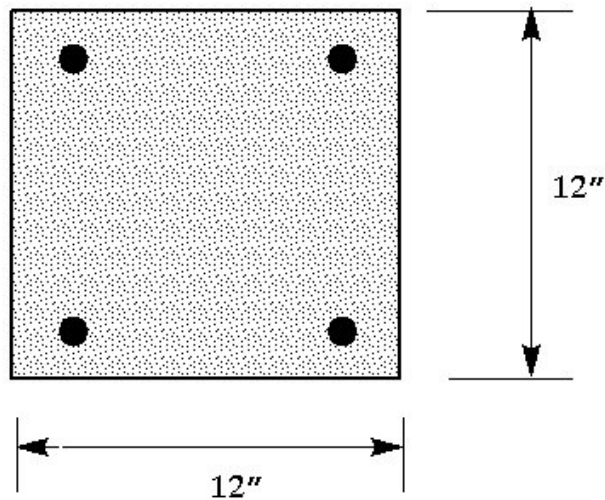

**Given:** 4 # 8 bars

Assume:  $f'_c = 4000$  psi  $f_y = 40$  ksi

area of steel = 4(area of # 8 bars)

$$4(0.79) = 3.16\text{in}^2$$

(see **ACI 318** - bar dimension table, or page iii of class notes)

$$\frac{A_s}{A_g} = \frac{3.16}{144} = 0.022 \text{ O.K. (ACI 318 Sect. 10.9 } 0.010 < 0.022 < 0.080)$$

What axial load will cause concrete to be at its maximum working stress?

**Solution:**

$$f'_c = \frac{4000}{2} = 2000 \text{ psi}$$

$$f_s = \frac{E_s}{E_c} f_c = nf$$

$$E_c = 57,000\sqrt{4000} = 3,600,000 \text{ psi}$$

$$E_s = 29,000,000 \text{ psi (always)}$$

(3.6)

$$\text{Therefore } \rightarrow n = \frac{E_s}{E_c} = \frac{29,000,000}{3,600,000} = 8.04 \approx 8$$

$$P = f_c(A_g + (n-1)A_s) = 2000[144 - (8-1)(3.16)] = 332,000\text{lbs} = 332\text{kips}$$

*both steel and concrete behave elastically*

### 3.3.2. Example 2

For the previous example find the axial load  $P$  which produces  $\epsilon_c = \epsilon_s = 0.001$ .

#### Solution

$$\epsilon_s < 0.001379 \rightarrow f_s = E_s \epsilon_s = 29,000,000(\text{psi}) \times 0.001 = 29,000 \text{ psi}$$

See the slow rate curve of text on page 26, read stress in concrete for given strain of 0.001

$$f_c = 2,400 \text{ psi}$$

therefore

$$\begin{aligned} P &= f_c A_c + f_s A_s \\ &= 2,400 \times (144 - 3.16) + 29,000 \times 3.16 \\ &= 338,016 + 91,640 = 429,655 \text{ lbs} = 430 \text{ kips} \end{aligned}$$

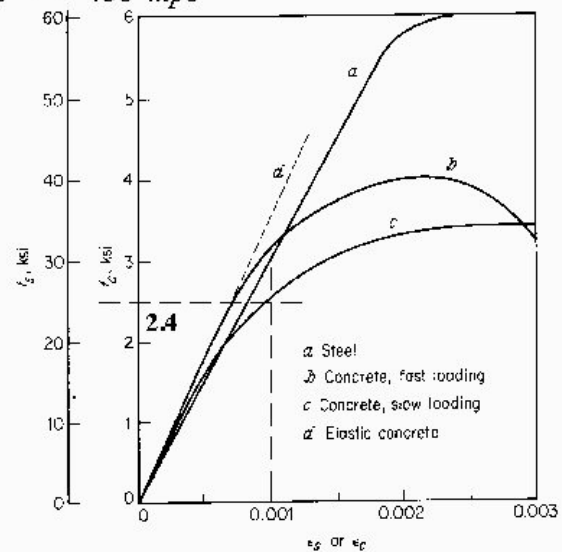
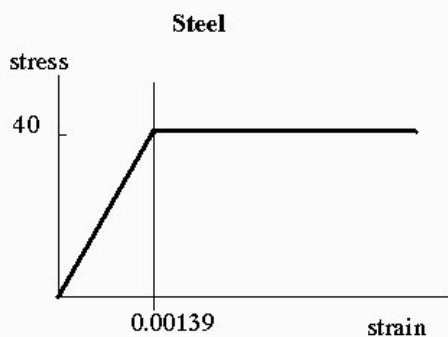



---

### 3.4. Nominal axial load of column $P_n$ ; ( $P_u = \Phi P_n$ ) - Greatest calculated load

A. Should occur when concrete stress peaks, steel reaches yield - assume this condition.

B. Concrete stress will not be  $f'_c$ :

- $f'_c$  based on test of standard cylinder; ends confined.;
- $f'_c$  depends on the rate of loading;
- Strength of actual column varies over length - water migrates to top, causing top to be slightly weaker.

$\Rightarrow$  use  $f_c = 0.85 f'_c$  at nominal load condition

then

$$\begin{aligned} P_N &= A_c f_c + A_s f_s \\ &= A_c (0.85 f'_c) + A_s f_y \end{aligned}$$

for column of previous example:

$$P_N = (144 - 3.16)(0.85)(4000) + 3.16(40,000) = 605 \text{ kips}$$

### 3.4.1. Example 3

Consider a rectangular column subjected to axial compression. The material stress-strain relationships have been idealized as shown below.

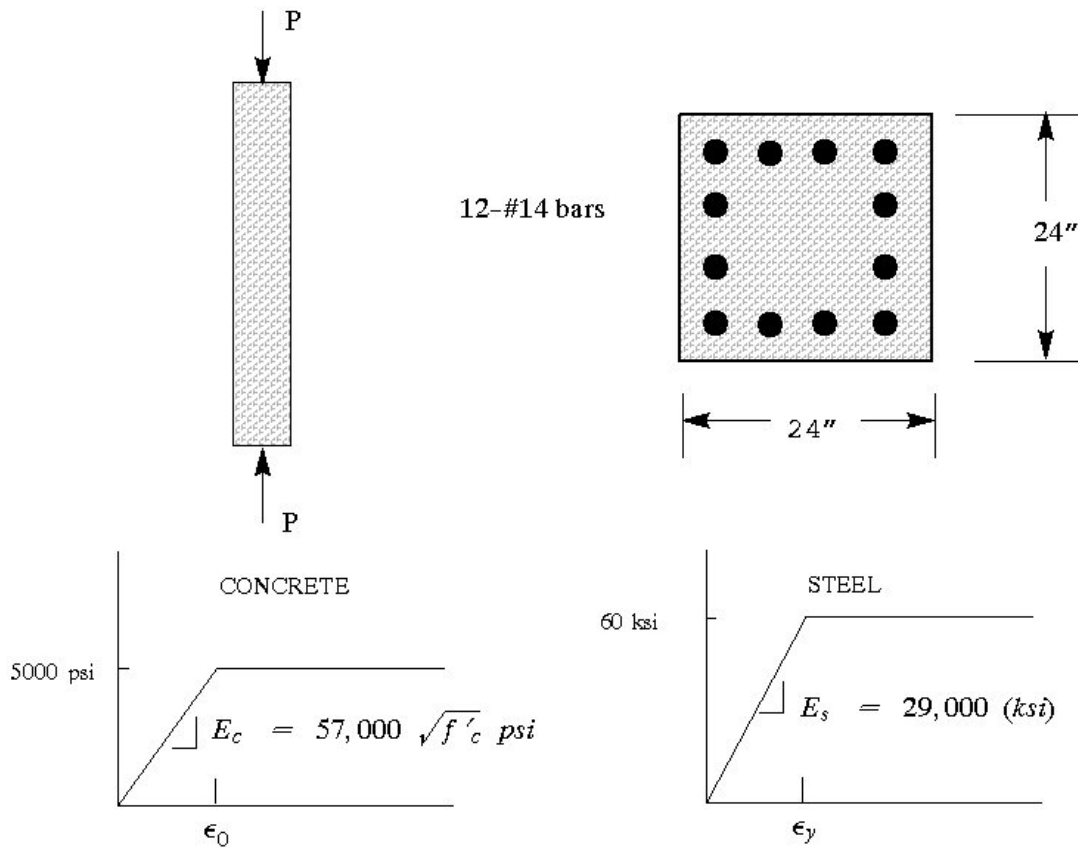

1. Determine the stress in the concrete and stress in the steel if the applied load is equal to 3100 kips.
2. Determine the stress in the concrete and stress in the steel if the applied load is equal to 4050 kips.

See the solution on the next page.

**Solution:**

- $f'_c = 5 \text{ ksi}$
- $E_c = 57,000 \sqrt{5000} = 4030 \text{ ksi}$  (Sect 8.5.1 of ACI)
- 12#14 bars  $A_s = 27 \text{ in}^2$  (from table A.2)
- $E_s = 29,000 \text{ ksi}$

1. Assume

$$\epsilon < \epsilon_0 \text{ or } \epsilon < 0.00124 \quad \text{Assume elastic behavior for}$$

$$\epsilon < \epsilon_y \text{ or } \epsilon < 0.00207 \quad \text{both steel and concrete}$$

$$P = f_c A_c + f_s A_s$$

$$\text{where } A_c = A_g - A_s = 24 \times 24 - 27 = 549 \text{ in}^2$$

$$P = 3100 = E_c \epsilon A_c + E_s \epsilon A_s \quad \text{Note: } \epsilon = \epsilon_c = \epsilon_s \text{ (perfect bonding)}$$

$$3100 = (4030)\epsilon(549) + (29000)\epsilon(27)$$

$$\epsilon = 3100 / (2,212,470 + 783,000) = 0.00103 < 0.00124 \text{ o.k. } \mathbf{\text{Assumption was correct.}}$$

Therefore we have:

$$f_s = \epsilon E_s = 0.00103 \times 29,000 = 29.9 \text{ ksi}$$

$$f_c = \epsilon E_c = 0.00103 \times 4,030 = 4.2 \text{ ksi}$$

2. Assume

$$\epsilon > \epsilon_0 \text{ or } \epsilon > 0.00124 \quad \text{Assume elastic behavior for}$$

$$\epsilon < \epsilon_y \text{ or } \epsilon < 0.00207 \quad \text{steel and inelastic behavior for concrete}$$

$$P = f_c A_c + f_s A_s$$

$$4050 = (5.00) \times (549) + (29,000) \epsilon (27)$$

$$\epsilon = 0.001667 > 0.00124 \text{ o.k. Assumption was correct (Concrete behaves inelastically).}$$

$$\epsilon = 0.001667 < 0.00207 \text{ o.k. Assumption was correct (Steel behaves elastically).}$$

$$f_s = \epsilon E_s = 0.001667 \times 29,000 = 48.3 \text{ ksi}$$

$$f_c = 5.000 \text{ ksi}$$

### 3.5. Behavior of Spirally Reinforced Columns

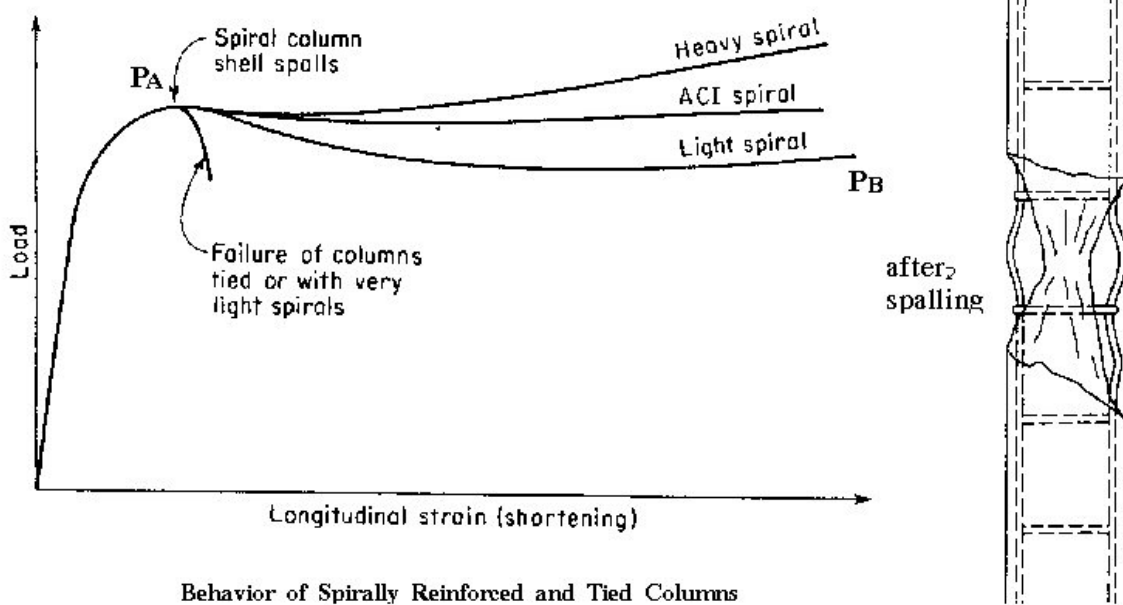

### 3.6. Confinement

A. ACI spiral reinforcement ratio based on tests by Richart, Brandtzege and Brown - 1928;

Using 6" x 12" cylinders, they related lateral confining pressure to axial capacity;

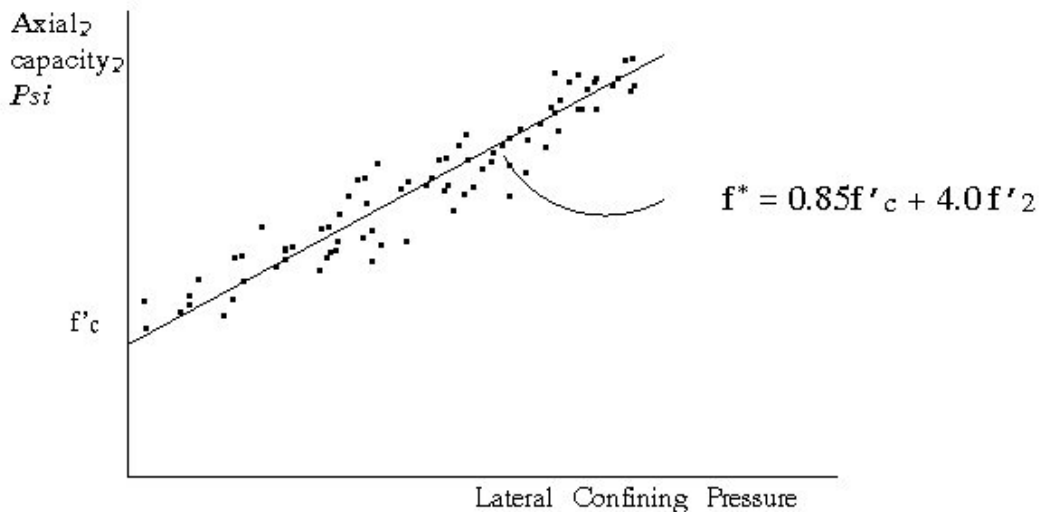

where

$f_c^*$  = Compressive strength of spirally confined core concrete

$0.85 f_c'$  = compressive strength of concrete if unconfined

$f_2'$  = lateral confinement stress in core concrete produced by spiral



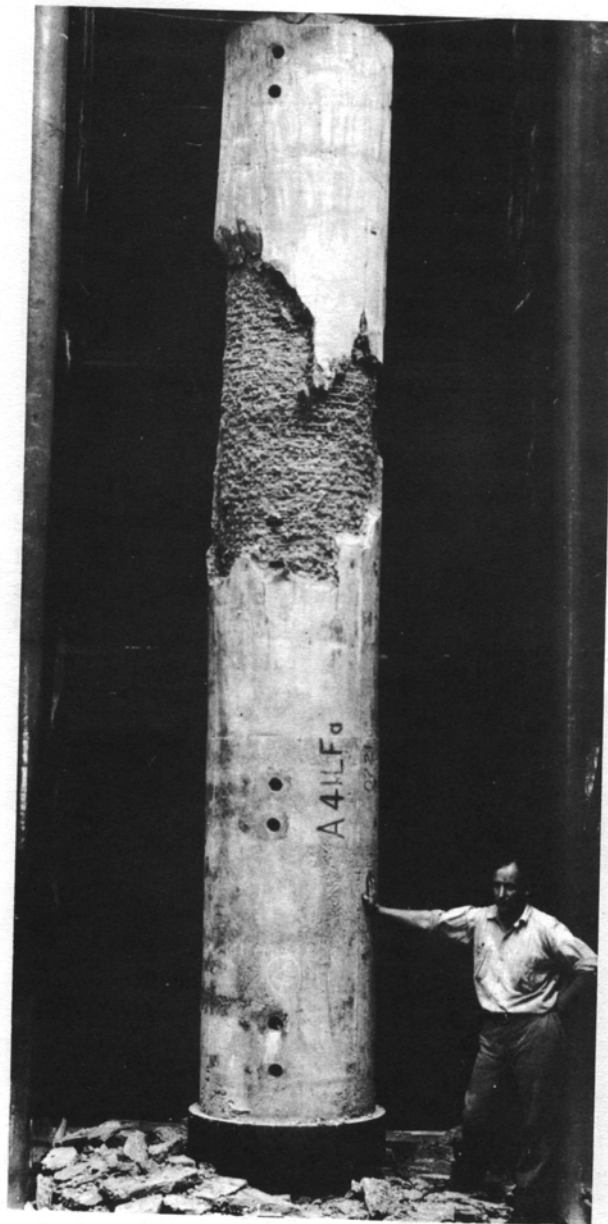

(a)



(b)



(c)

### Spiral Column











B. What sort of lateral confinement can a given spiral provide?

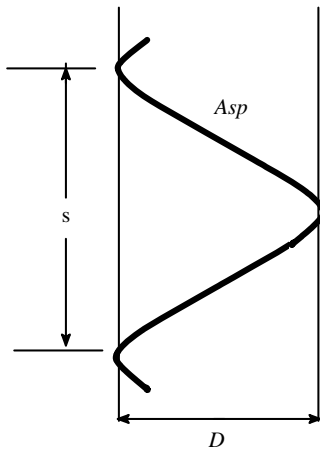

Consider a length of a spiral-wrapped circular section:

for a length "S":

volume of spiral =  $A_{sp}\pi D$  (approximately)

volume of concrete =  $(\pi D^2/4)S$

$$\text{Let } \rho_s = \frac{\text{volume of spiral}}{\text{volume of concrete}} = \frac{4A_{sp}}{DS}$$

Calculate equivalent confinement:

$$f'_2 DS = 2 A_{sp} f_{ys} \quad \text{or} \quad f'_2 = (\rho_s f_{ys})/2$$

from previous research:

$$f_c^* = 0.85 f'_c + 4.0 f'_2 = 0.85 f'_c + 4.0 \frac{\rho_s f_{ys}}{2}$$

$$f_c^* = 0.85 f'_c + 2.0 \rho_s f_{ys}$$

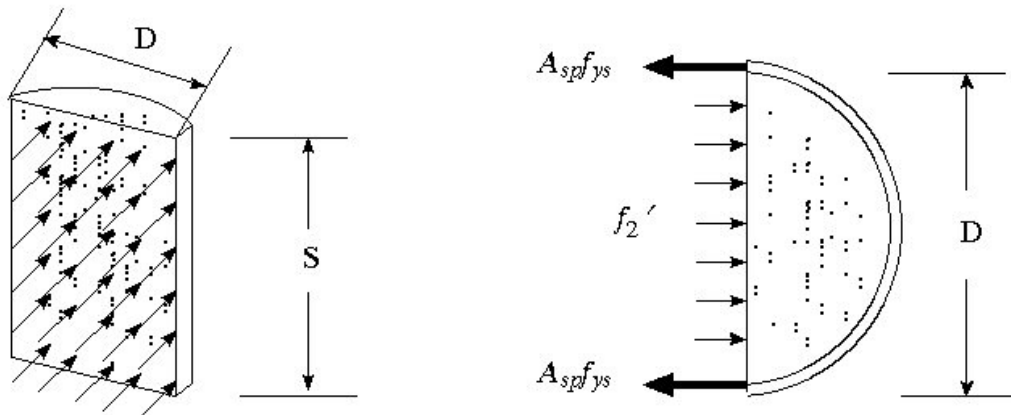

ACI objective is to insure that  $P_B > P_N$ .

Therefore, make sure spiral increases capacity of core enough to make up for loss of shell.

Before shell spalls:  $P_N = A_s f_y + 0.85 f'_c (A_g - A_s)$

After shell spalls:  $P_B = A_s f_y + (A_{core} - A_s)(0.85 f'_c + 2 \rho_s f_{ys})$

Set  $P_B = P_N$ , calculate like terms, expand:

$$A_s f_y + 0.85 f'_c A_g - 0.85 f'_c A_s = A_s f_y + A_{core} (0.85 f'_c + 2 \rho_s f_{ys}) - A_s (0.85 f'_c) - 2 A_s \rho_s f_{ys}$$

Ignore the last term - very small

then

$$0.85 f'_c (A_g - A_{core}) = A_{core} (2 \rho_s f_{ys}) \quad (3.7)$$

solve for spiral reinforcement ratio we have:

$$\rho_s = \frac{0.85 f'_c (A_g - A_{core})}{A_{core} (2 f_{ys})} \quad (3.8)$$

or

$$\rho_s = \frac{0.425 f'_c \left( \frac{A_g}{A_{core}} - 1 \right)}{f_{ys}} \quad (3.9)$$

conservatively, change 0.425 to 0.45 to get Eq. 10-6 of **ACI**:

$$\rho_s = \frac{0.45 f'_c \left( \frac{A_g}{A_{core}} - 1 \right)}{f_{ys}} \quad ACI(Eq.10-6) \quad (3.10)$$

which says that the ratio of spiral reinforcement shall not be less than the value given by the equation above; where  $f_y$  is the specified yield strength of spiral reinforcement but not more than 60,000 psi.

### 3.7. Maximum Loads for Spiral Column

Prior to spalling of shell: same as tied column

$$P_A = P_N = A_s f_y + 0.85 f'_c (A_g - A_s) \quad (3.11)$$

after spalling of shell:

$$P_B = A_s f_y + (A_{core} - A_s) (0.85 f'_c + 2 \rho_s f_{ys}) \quad (3.12)$$

or

$$P_B = A_s f_y + (A_{core} - A_s) 0.85 f'_c + (A_{core} - A_s) (2 \rho_s f_{ys}) \quad (3.13)$$

The underlined term is the added capacity of the core resulting from the presence of the spiral.

where will  $\rho_s$  be critical?

- High strength concrete (shell carries large loads);
- Small columns or square columns;
- Columns with large cover.

### 3.7.1. Example - Ultimate Strength of Spiral Column

Choose a column with areas equivalent to those of previous example (page )

$$\begin{aligned} A_g &= 144 \text{ in}^2 & f'_c &= 4000 \text{ psi} \\ A_{core} &= (\pi(10.6)^2/4) = 87.4 \text{ in}^2 & f_y &= 40 \text{ ksi} \\ A_s &= 3.16 \text{ in}^2 & s &= 1.5 \text{ in} \\ & & f_{ys} &= 50 \text{ ksi} \end{aligned}$$

Use (3/8)" diameter spiral:  $A_{sp} = 0.11$

$$\begin{aligned} \frac{A_s}{A_g} &= \frac{3.16}{144} = 0.022 \quad O.K. \\ \rho_s &= \frac{4A_{sp}}{DS} = \frac{4 \times 0.11}{10.6 \times 1.5} = 0.028 \end{aligned}$$

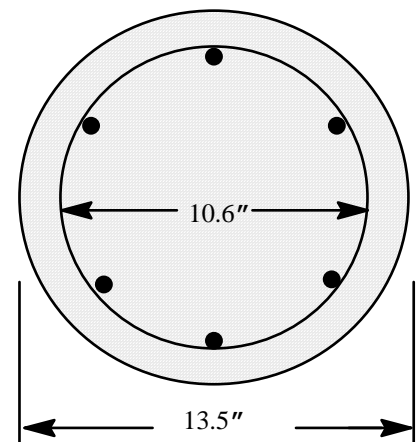

Check spiral ratio against ACI requirements

$$\rho_s = \frac{0.45 f'_c}{f_{ys}} \left( \frac{A_g}{A_{core}} - 1 \right) = \frac{0.45(4)}{50} \left( \frac{144}{87.4} - 1 \right) = 0.023 \quad (3.14)$$

Since  $0.028 > 0.023$ , the column satisfies the minimum spiral reinforcement requirements.

Load prior to shell spalling:

$$\begin{aligned} P_A = P_N &= A_s f_y + 0.85 f'_c (A_g - A_s) = 3.16(40) + 0.85(4)(144 - 3.16) \\ &= 605 \text{ kips - same as tied column. (compare this with the axial} \\ &\quad \text{capacity we found in page 37).} \end{aligned} \quad (3.15)$$

After spalling of shell:

$$\begin{aligned} P_B &= A_s f_y + (A_{core} - A_s) 0.85 f'_c + (A_{core} - A_s) (2 \rho_s f_{ys}) \\ &= 0.85(4)(87.4 - 3.16) + 2(0.028)(50)(87.4 - 3.16) + 3.16(40) \\ &= 647.8 \text{ kips or 648 kips} \end{aligned} \quad (3.16)$$

---

### 3.8. ACI Provisions for Spiral Columns

ACI 10.3.6.1

$$\phi P_n (\text{max}) = 0.85\phi \left[ A_{st} f_y + 0.85 f'_c (A_g - A_{st}) \right] \quad \text{ACI (10-1)} \quad (3.17)$$

---

### 3.9. ACI Provisions for Tied Columns

ACI 10.3.6.2

$$\phi P_n (\text{max}) = 0.80\phi \left[ A_{st} f_y + 0.85 f'_c (A_g - A_{st}) \right] \quad \text{ACI (10-2)} \quad (3.18)$$

---

### 3.10. Strength and Serviceability

1. ACI assigns two types of safety factors for design:
  - a. Load factor - increase design loads (ACI 9.2)  
Dead load - 1.2  
Live load - 1.6
  - b. Strength reduction factor - reduce calculated design capacity - variability of material and construction.
2. Columns are assigned the following strength reduction factor (ACI 9.3.2.2)  
Tied column - 0.65  
Spiral column - 0.70

spiral column allowed more because of ductility.

### 3.11. Example - Design of Axial Members under Axial Loads

Design a rectangular tied column to accept the following service dead and live loads. Ignore length effects.

**Given:**

$$P_D = 142 \text{ kips}$$

$$P_L = 213 \text{ kips}$$

$$f'_c = 4000 \text{ psi}$$

$$f_y = 60 \text{ ksi}$$

**Solution:**

We need to find  $b$ ,  $h$ , and  $A_s$ . Sometimes architectural considerations limit allowable column width and height sizes to a set of given dimensions. In this case one needs to determine the reinforcement area and detail the column. For this problem assume that we do not have any architectural limitations.

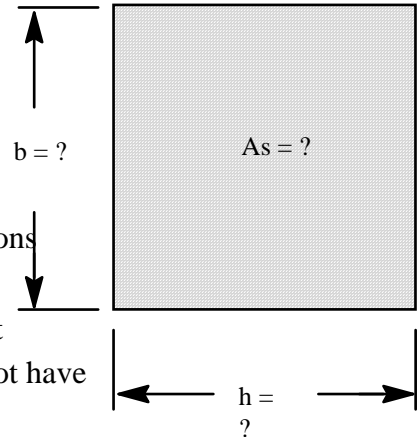

Calculate design loads:

$$P_u = 1.2P_D + 1.6P_L = 1.2 \times 142 + 1.6 \times 213 = 511.2 \text{ kips}_L$$

For the first trial use a 12" by 12" column ( $b = 12$  in and  $h = 12$  in). From ACI 10.3.5.1 we have

$$P_u = \phi P_n (\text{max}) = 0.80\phi \left[ A_{st} f_y + 0.85 f'_c (A_g - A_{st}) \right]$$

$$P_u = 0.80(0.7) \left[ A_{st} (60) + 0.85(4)(144 - A_{st}) \right] = 29.43A_{st} + 254.6$$

therefore

$$511.2 = 29.43A_{st} + 254.6 \rightarrow A_{st} = 8.72 \text{ in}^2$$

Therefore, use 4-#9 and 4-#10 bars with  $A_s = 9.06 \text{ in}^2$

Check ACI 10.9

$$\frac{A_s}{A_g} = \frac{9.06}{144} = 0.063 \text{ ok}$$

ACI Code requires (ACI, Sect 7.10.5.2) that spacing not to be greater than

$$16 \text{ (bar diameter)} = 16 \times 1.00 = 16.0 \text{ in}$$

$$48 \text{ tie bar diameter} = 48 \times 0.5 = 24 \text{ in (0.5 diameter of #4 ties)}$$

$$\text{Least member dimension} = 12 \text{ in}$$

Use #4 bars for ties with 12 inches of spacing.

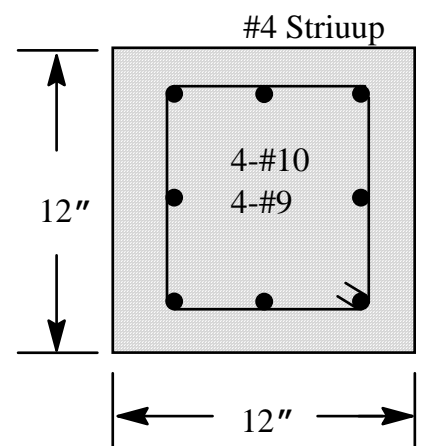

---

## 3.12. Design of a Spiral Column

Design a spiral column to carry a dead load of 175 kips and a live load of 300 kips. The given loads are axial loads. Use 3000 psi concrete and 40,000 psi steel.

Assume zero eccentricity:

$$P_u = 1.2P_D + 1.6P = 1.2 \times 175 + 1.6 \times 300 = 690 \text{ kips}_L$$

$$\text{assume } \rho_g = \frac{A_s}{A_g} = 0.02$$

From ACI318, section 10.3.5.1 (Equation 10-1) we have

$$P_u = \phi P_n (\text{max}) = 0.85\phi \left[ A_{st} f_y + 0.85 f'_c (A_g - A_{st}) \right]$$

or, factor out  $A_g$  from the bracket

$$P_u = \phi P_n (\text{max}) = 0.85\phi A_g \left[ \rho_g f_y + 0.85 f'_c (1 - \rho_g) \right]$$

for spiral columns  $F = 0.75$ , therefore, we have

$$690 = 0.85(0.7)A_g \left[ (0.02)(40\text{ksi}) + 0.85(3\text{ksi})(1 - 0.02) \right]$$

Solve for  $A_g$

$$A_g = 352 \text{ in}^2$$

$$A_g = \frac{\pi}{4} D_g^2 = 352 \text{ in}^2 \rightarrow D_g = 21.18 \text{ in} \text{ round to } 21.5 \text{ in}$$

The required steel area is

$$A_s = \rho A_g = 0.02359 = 7.18 \text{ in}^2$$

Try 12#7 ( $A_s = 7.22 \text{ in}^2$ ) bars.

### 3.13.1. Check Spacing Requirements

Use 1.5 in cover. The core diameter is (ACI 7.7.1)

$$21.5 - 2 \left( 1 \frac{1}{2} \right) = 18.5 \text{ in} \tag{3.19}$$

Using #3 spiral wire, the steel diameter is

$$21.5 - 2\left(1\frac{1}{2}\right) - 2\left(\frac{3}{8}\right) - \left(\frac{7}{8}\right) = 16.875 \text{ in} \quad (3.20)$$

The steel circumference is

$$\pi(16.875) = 53 \text{ in} \quad (3.21)$$

The clear spacing between bars is

$$\frac{53 - (12)(0.875)}{12} = 3.54 \text{ in} \quad (3.22)$$

Since  $3.54 \text{ in} > (1.5) d_b = (1.5)(0.875) = 1.31 \text{ in}$ , this is acceptable (ACI 7.6.3). In addition, the minimum amount of spiral reinforcement as given in Eq. 10-6 of ACI needs to be checked.

### 3.13.2. Check Minimum Steel Requirements for Spiral Steel

$$\rho_s = \frac{0.45 f'_c}{f_{ys}} \left( \frac{A_g}{A_{core}} - 1 \right) = \frac{0.45(3,000)}{40,000} \left( \frac{\pi(12^2)/4}{\pi(18.5^2)/4} - 1 \right) = 0.0118 \quad (3.23)$$

Assuming a spiral pitch,  $S = 2$  inches,

$$\rho_{sactual} = \frac{4A_{sp}}{DS} = \frac{40.11}{218.5} = 0.0119 > 0.0118 \text{ acceptable}$$

The clear spacing between spirals is

$$2 - \frac{3}{8} = 1.625 \text{ in}$$

Since  $1.0 \text{ in} < 1.625 \text{ in} < 3 \text{ in}$ , this is acceptable

### 3.13. Homework Set 3

A. Consider a rectangular column subjected to axial compression. The material stress-strain relationships have been idealized as shown below.

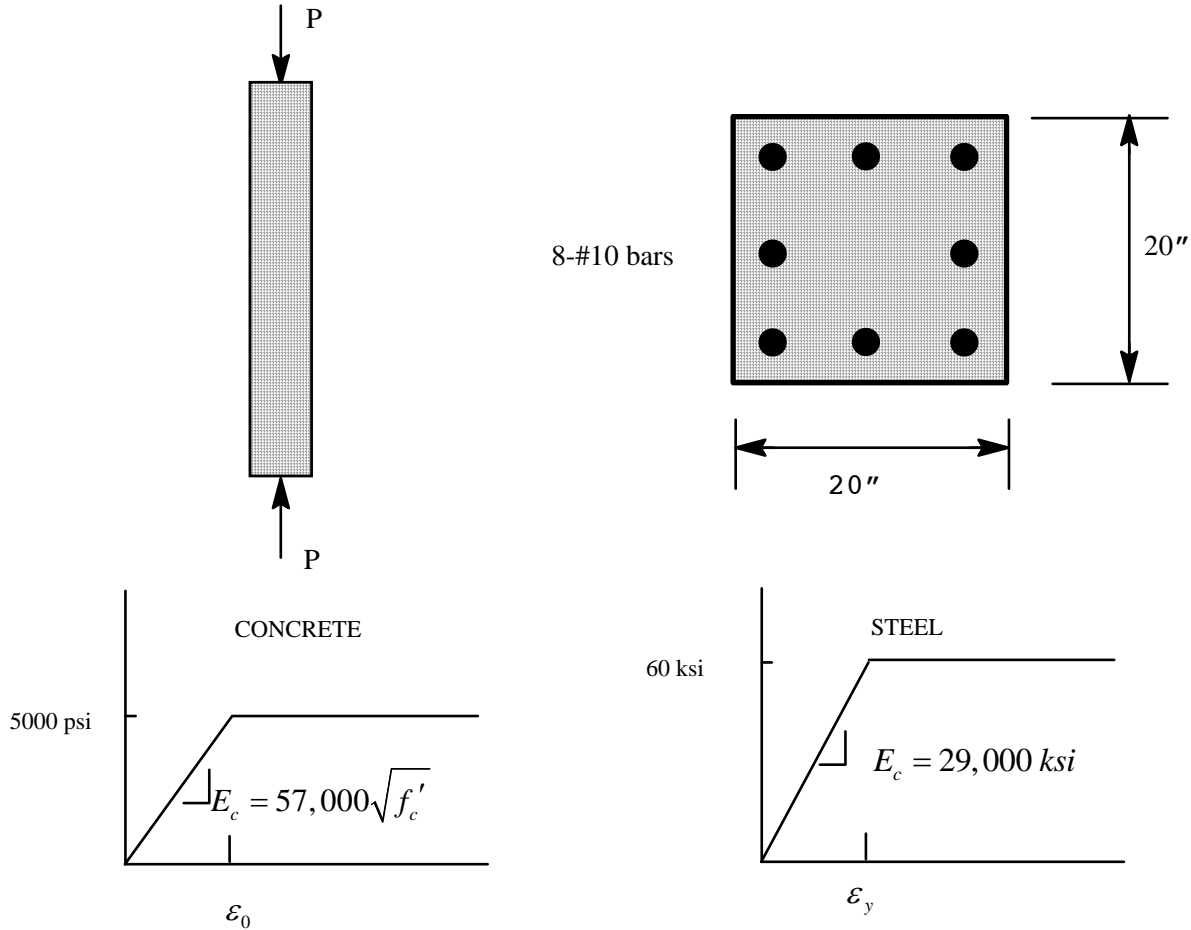

1. Determine the stress in the concrete and stress in the steel if the applied load is equal to 1,800 kips.

ans: steel: ? ksi concrete: ? ksi

2. Determine the stress in the concrete and stress in the steel if the applied load is equal to 2,200 kips.

ans: steel: ? ksi concrete: ? ksi

3. Determine the maximum axial load that can be supported by the column (Ultimate Strength according to ACI).

$P_n = ?$  and  $P_u = ?$



B. Do the following for the column described below:

Assume the column to be spiral column with the spiral properties given and calculate the loads right before spalling of concrete shell and after spalling of concrete shell. Does the spiral satisfy the code for minimum spiral ratio (Eq. 10-6 of ACI).

Longitudinal reinforcement 6#9 bars,  $f_y = 50$  ksi;  
 Spiral diameter 1/4 inch, with 1.5 inch spacing;  
 $f_{ys}$  (yield stress for spiral reinforcement) = 70 ksi;  
 $f'_c = 4,000$  psi.

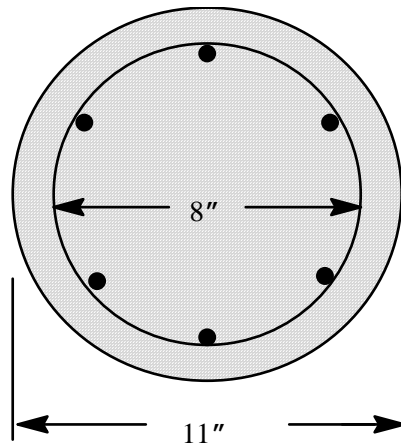

Answer:  $P_A$  = \_\_\_\_\_ kips  
 $P_B$  = \_\_\_\_\_ kips

C. Design a **spiral column** and a **tied column** to carry a dead load of 410 kips and a live load of 400 kips. The given loads are axial loads. Use 4000 psi concrete and 60,000 psi steel. Detail your designs.