

NEW  
per the  
'02 NEC

# Carlton® Electrical Nonmetallic Tubing (ENT) Application Handbook

---



**Carlton®**  
LAMSON & SESSIONS

© Carlon 2002.  
All rights reserved.

The cover and entire contents of this handbook are fully protected and may not be reproduced in any manner without the expressed written consent of Carlon.

# Introduction

---

This pocket handbook is intended to be used as a guide for the installer of the Carlon brand of Electrical Nonmetallic Tubing (ENT) to answer general questions relating to installation procedures. For information on part numbers or pricing, please refer to the appropriate Carlon catalog.

Should the installer develop any unique installation or support methods not shown in this manual, please photograph the method with a 35mm camera only and contact your local Carlon sales representative.

**THIS POCKET HANDBOOK IS INTENDED AS A GUIDE FOR GENERAL PURPOSES ONLY. CARLON ACCEPTS NO LIABILITY FOR ANY DAMAGES OR LOSS WHICH MAY RESULT FROM IMPROPER INSTALLATION OF ENT.**

## Table of Contents

<b>Section</b>	<b>Page</b>
1. General Information and Questions about ENT . . . . .	2
2. Embedded ENT . . . . .	9
3. Wood and Metal Stud Construction . . . . .	17
4. Masonry Construction . . . . .	23
5. Exposed Construction . . . . .	25
6. Above a Suspended Ceiling . . . . .	28
7. Boxes and Supports . . . . .	31
8. Field Expediency and Tips . . . . .	35
9. Tables, Charts, etc. (Reference type of tables) . . . . .	40
10. Article 362 and Associated Articles . . . . .	46
11. Miscellaneous . . . . .	69
12. Flex-Plus® Blue™ ENT . . . . .	70

# Section 1

---

## General Information and Questions about Carlon® Flex-Plus® Blue™ ENT

### Features:

- UL Listed
- CSA Certified
- Lightweight
- Nonconductive
- Color-coded
- Hand bendable (pliable), no sharp edges
- Clean
- Available in long-length coils and reels to reduce scrap
- Available in 1/2 inch through 2 inch sizes
- Available with a complete line of fittings and accessories that are compatible with PLUS 40®, PLUS 80® PVC Conduit and Schedule 40 fittings
- Easy to work with, no special tools required
- Speeds installation time
- A time saver when pulling wire
- When this handbook refers to ENT, it is referenced as Carlon Flex-Plus Blue ENT as published in Carlon catalogs



*Complete size range 1/2" through 2"*

# Questions about ENT

## 1. WHAT IS ENT?

ENT is a pliable, nonmetallic raceway manufactured of the same material (PVC) used for rigid nonmetallic conduit.

## 2. IS ENT UL LISTED?

Yes. See UL Listing No. E73317 for 1/2 inch through 2 inch ENT

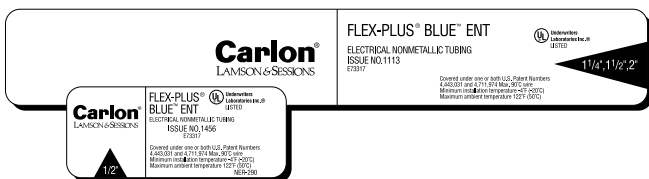

## 3. IS ENT RECOGNIZED BY THE NEC?

Yes. See Article 362 (Article 331 of the NEC) – Electrical Nonmetallic Tubing (see Section 10 of this manual.)

## 4. ARE THERE ANY OTHER NATIONAL ORGANIZATIONS THAT RECOGNIZE THE USE OF ENT?

Yes. CABO – The Council of American Building Officials.

## 5. HOW LONG HAS ENT BEEN IN EXISTENCE?

Carlon introduced ENT in 1980 and is presently the largest manufacturer of all PVC conduit, boxes and fittings.

## 6. WHAT IS THE FIRE RATING OF ENT?

BOCA, SBCCI and ICBO recognize the use of ENT in a one and two hour fire rated Wall Assembly and up to a three hour rated Floor/Ceiling Assembly. (Reference ER-5644 or NER-290).

## 7. IS THERE ANY CONCERN REGARDING THE TOXICITY OF ENT DURING A FIRE?

- PVC raceways have never caused death in a fire situation, however, improperly grounded steel raceways have ignited fires by arcing and sparking.
- Smoke from ENT raceways is no more hazardous than smoke from other materials commonly used in the

construction and contents of a building such as furniture, wall coverings, carpeting, drapes, wood, and paper. Wool carpeting and upholstery produce deadly hydrogen cyanide gas. Wood produces carbon monoxide, a primary cause of fire deaths. These materials ignite at a much lower temperature than ENT.

c. Various tests conducted by combustion toxicologists, third party certifying agencies, and testing laboratories conclusively prove:

- PVC Raceways DO NOT generate HCl (Hydrogen Chloride) in lethal concentrations.
- In an actual large scale fire test, PVC conduit maintained the integrity of electrical circuits, even in the case of flashover.
- In a fire situation, PVC conduit will protect the integrity of conductors significantly longer than steel conduit.
- PVC is a practical conduit material.
- Metallic conduit systems do not guard against fire ignition (may promote arcing if not properly grounded.)
- PVC conduit is superior to metallic conduit in most applications.
- Since both metallic and nonmetallic raceways are recognized by NEC, the buyer can decide which product is best suited to the installation requirement.
- A real concern for life safety in fires must be directed toward eliminating fire ignition, providing better control of burnables in the room and priding state-of-the-art fire protection and sprinkler systems. These are the goals of many recognized fire authorities.

## 8. HOW EASY IS ENT TO HANDLE ON THE JOB?

### Let's take a look:

1/2 inch ENT weighs 11 pounds per 100 feet.

1/2 inch EMT weighs 29 pounds per 100 feet  
(or one bundle).

You can easily carry two coils of ENT (200 feet per coil) weighing 44 pounds, compared to 4 bundles of EMT (10 feet long per bundle) weighing 116 pounds.

## Let's look at the sizes:

- A 200 foot coil of ENT is 22" × 22" square × 8½" deep.
- A 200 foot bundle of EMT is 10' long by approximately 20" in circumference.

Now how easy is it for one man to carry 200 feet of EMT conduit and negotiate stairways and hallways? Try this same experiment with Carlon ENT. It's much easier isn't it?

## 9. HOW EASY IS ENT TO INSTALL?

Very easy! All that is needed for installation is a Carlon conduit cutter, an electrician's knife or utility knife, tiewraps or tiewire, and a pair of side cutter pliers. That's all! Contractors have said that Carlon ENT can be installed in half the time of installing comparable EMT conduit.

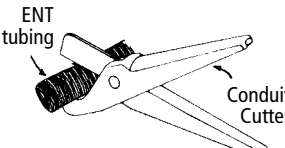
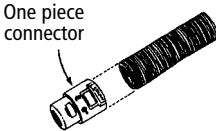
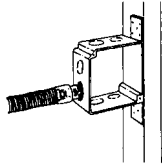
<b>One Piece Quick Connect Fitting</b> Simple as 1-2-3 (Illustration 1-6-1)	
<p><b>1. Cut</b> (No need to ream or deburr)</p>  <p>ENT tubing</p> <p>Conduit Cutter</p>	<p><b>2. Snap on</b> Terminator to ENT</p>  <p>One piece connector</p>
<p><b>2. Snap in</b> Terminator to Box</p> 	
<p><b>Done.</b> Elapsed time: Less than 15 seconds Tools: Carlon conduit cutter</p>	

## 10. WHAT DOES CARLON OFFER WHEN USING ENT FOR COMMUNICATIONS AND FIRE PROTECTION SYSTEMS?

Carlon also offers yellow and red ENT. All ENT must be installed in accordance with NEC Article 362 (see Section 10 of this manual).



**One Piece Quick Connect fitting**



**Schedule 40 Male Threaded Adapter**

## 11. WHAT KIND OF ENT FITTINGS DOES CARLON OFFER?

Carlton offers a complete line of one piece quick connect fittings in sizes 1/2 inch through 1 inch. For ENT sizes 1 1/4 inch through 2 inch, the use of PVC Schedule 40 cemented fittings is necessary. Carlton also offers PVC cemented fittings for 1/2 inch through 1 inch.

## 12. HOW EASY IS IT TO PULL WIRE THROUGH ENT?

Very easy! In fact, a field test showed that it required only 1.5 minutes for an electrician to push through 3-No. 12 wires through 40 feet of 1/2 inch ENT with the equivalent of four 90° bends. Remember, the corrugated construction of ENT allows only one-half of the total length of installed ENT to be in direct contact with the wire being installed (for Wirefill sizes, see Section 9, Table 9-7 of this manual.)

## 13. HOW IS ENT PACKAGED?

ENT is packaged in:

a. Straight lengths

- 1/2 inch ENT 20 10' pieces per bundle
- 3/4 inch ENT 10 10' pieces per bundle
- 1 inch ENT 10 10' pieces per bundle

b. Coils

- 1/2 inch ENT 200' per coil
- 3/4 inch ENT 100' per coil
- 1 inch ENT 100' per coil

c. Reels

- 1/2 inch ENT 1500' per reel
- 3/4 inch ENT 1000' per reel
- 1 inch ENT 750' per reel
- 1 1/4 inch ENT 750' per reel
- 1 1/2 inch ENT 750' per reel
- 2 inch ENT 500' per reel





## 14. WHERE CAN I USE ENT?

ENT can be used in place of EMT, Rigid Galvanized Steel, AC or MC/ cable and NM cable. Just refer to Section 362.10 of NEC (see Section 10 of this manual.) ENT can be used in residential, commercial, schools, condominiums, apartments and industrial applications.

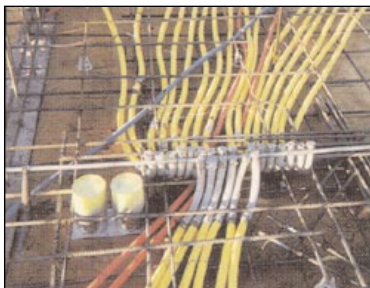

*On Deck Installation – Commercial*



*Metal Stud Installation – School*



*Wood Stud Installation – Condominium*



*On Deck Installation – Hospital*

## **15. WHAT IF I HAVE ANY QUESTIONS THAT WERE NOT COVERED IN THIS MANUAL?**

- Just call Carlon at (216) 766-6532 or 1-800-321-1970 (outside of Ohio) or contact your local Carlon sales representative.
- Visit our website at [www.carlon.com](http://www.carlon.com).

# Section 2

---

## Embedded ENT

REFERENCE NEC SECTION 362.10 USES PERMITTED:

The use of Carlon Electrical Nonmetallic Tubing and fittings shall be permitted:

- (6) Encased in poured concrete, or embedded in a concrete slab on grade where ENT is placed on sand or approved screenings, provided fittings identified for this purpose are used for connections.

REFERENCE NEC SECTION 362.10 USES NOT PERMITTED:

Electrical nonmetallic tubing shall not be used:

- (5) For direct earth burial.
1. Since ENT is manufactured in 1/2 inch through 2 inch, it can be installed quickly in most types of concrete floors, either slab on grade or in multi-story building. PLEASE CHECK YOUR JOB SPECIFICATIONS for any particular requirements of concrete cover.



*Multi-Story*



*Slab On Grade*

2. Ideally, one continuous length of ENT should be installed from box-to-box, but if the long lengths are not available, the run can be made using shorter lengths coupled together.
3. Carlon ENT is a pliable raceway that is not designed for flexible use in final connections to motors, A.C. units or other machinery where a flexible connection is necessary. In such instances, use Carlon® Carflex® Liquidtight Flexible Nonmetallic Conduit (ref. NEC Article 356) (see Section 10 of this manual.)
4. Ease of installation of ENT enables you to meet to the concrete pour schedule, and with ENT's versatility and pliability, installation rearrangements can be achieved just prior to the pour.
5. The biggest advantage of ENT is its ability to resist breaking, kinking, or crushing when installed and prior to the pouring of concrete. This eliminates costly rework and comebacks by the electrical contractor.



***Workers standing on ENT***

6. The installation of Carlon ENT isn't any different than the installation of comparable metallic conduit in a slab. ENT is installed on the first layer of rebar. The ENT is tied to the rebar every 3 feet with duct tape, tiewraps or tiewire. This will prevent floating of the ENT and hold it in position during the pouring of concrete.

# Questions About ENT

## 1. WHAT ABOUT STUB UPS OF ENT?

First, read your job specifications for any particular requirements. Then refer to Carlon suggested stub up methods shown in this section.

## 2. WHAT FITTINGS DO I USE WHEN INSTALLING 1/2 INCH THROUGH 1 INCH ENT IN CONCRETE?

Carlon offers a complete line of one piece quick connect fittings. These fittings are suitable for damp locations and are concrete-tight when used with Carlon ENT and a flat sealing washer on the box connection end. Remember, when using Carlon one piece quick connect fittings, NO TAPING IS NEEDED.

## 3. WHAT FITTINGS DO I USE WHEN INSTALLING LARGER CONDUIT 1 1/4 INCH THROUGH 2 INCH ENT TERMINATIONS?

All Schedule 40 fittings are compatible with ENT using Carlon Blue ENT cement.

## 4. WHAT DO I USE FOR STUB DOWNS OF ENT?

For stub downs of ENT when installed in a deck, fabricate a stub down (see illustration 2-1 in this section.)

REFERENCE NEC SECTION 362.10:

(7) For wet locations indoors as permitted in this section or in a concrete slab on or below grade, with fittings listed for the purpose.

This Section (7) permits the use of ENT in wet locations providing fittings identified for this purpose are used. The identified fittings are solvent cemented (glue-on) fittings of the type used for Schedule 40 rigid PVC conduit.

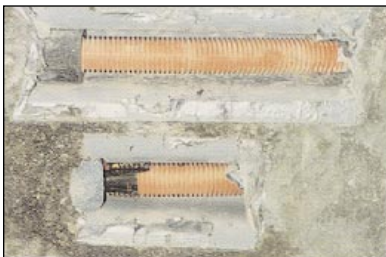

***Fabricated Stub Down***

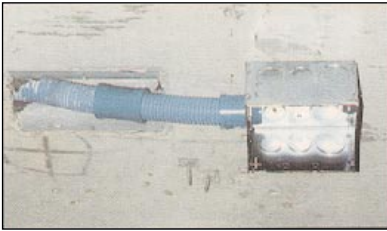

***Stub Down into Box***



***ENT in a Floor Slab prepared for more form work to extend conduits in the next pour.***



***ENT and Rigid PVC Conduit Stub Ups prepared for the pour***



***Stub Down Using Carlon's PV Mold***

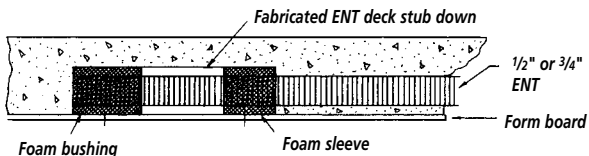

Initial installation before form is Stripped

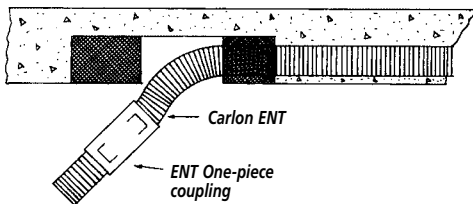

After Stripping

### ENT Stub Down (Illustration 2-1)

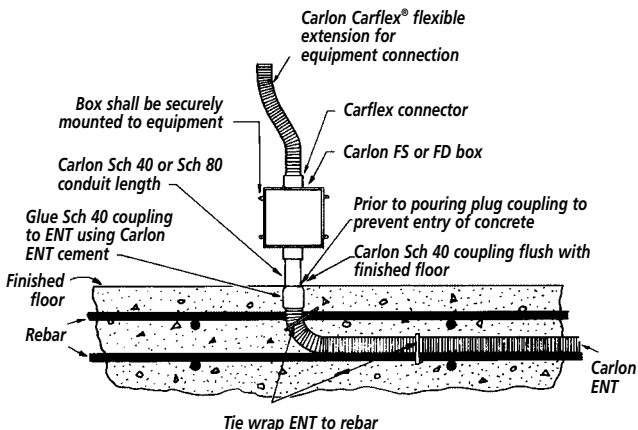

### Equipment Stub Up (Illustration 2-2)

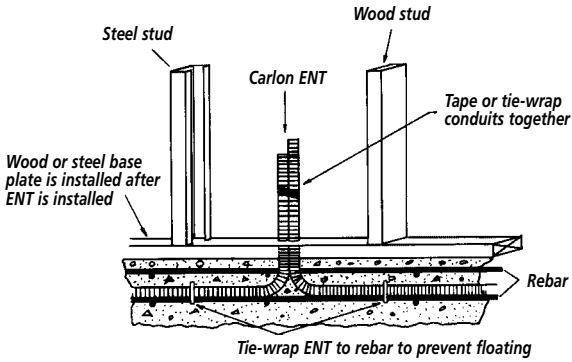

## Stub Up in Walls (Illustration 2-3)

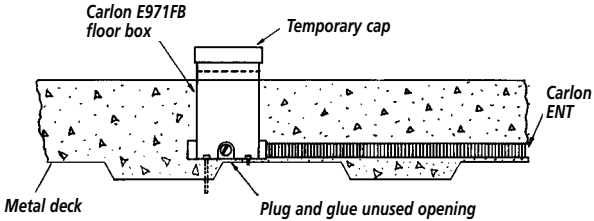

## Stub Into Single Circuit Floor Box (Illustration 2-4)

$1/4$ " or  $3/8$ " plain rods  
drive into ground to  
support template  $3$ " -  $4$ "  
above top of pour

$1/4$ " or  $3/8$ " plywood

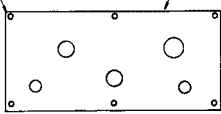

Tape ENT to hold in template

Caddy push nuts (2 per rod)

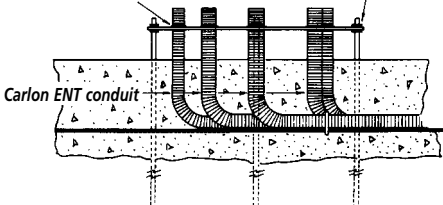

## Stub Up into Control Cabinet or Switchgear (Illustration 2-5)



Tape top of ENT sleeve prior to pour to prevent entry of concrete. Sleeve can be left as long as needed or cut flush with finished floor

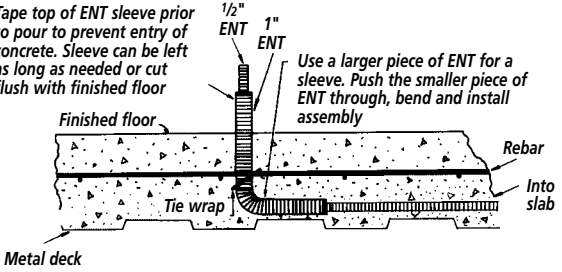

**Stub Up with ENT Sleeve**  
(Illustration 2-6)

After installation of sleeve and ENT, space between ENT and the sleeve can be troweled or foamed with fireproofing compound. (Follow manufacturer's recommendations)

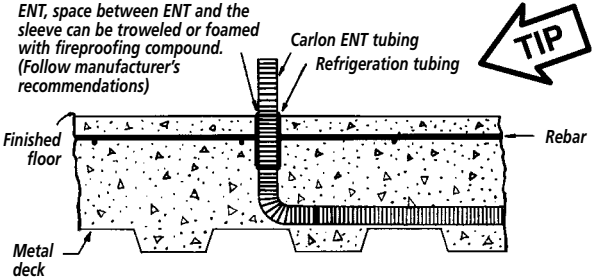

**Stub Up with Refrigeration Tubing**  
(Illustration 2-7)

PVC Sch 40 90° Elbow stub-size as required by job specifications

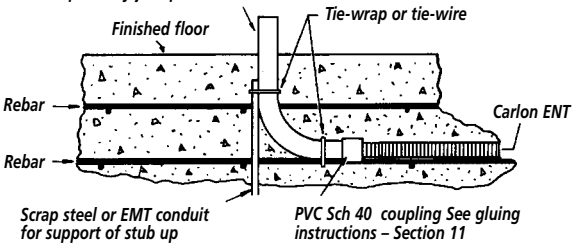

**Stub Up using Sch 40 Elbow**  
(Illustration 2-8)

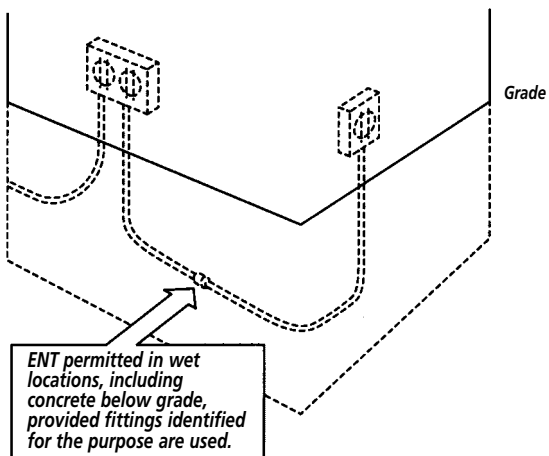

## **ENT in Wet Conditions**

*(Illustration 2-9)*

# Section 3

## Wood and Metal Stud Construction

Reference NEC Section 362.10 Uses Permitted: The use of electrical nonmetallic tubing and fittings shall be permitted:

- (2) In any building exceeding three floors above grade, ENT shall be concealed within walls, floors, and ceilings where the walls, floors, and ceilings provide a thermal barrier of material that has at least a 15 minute finish rating as identified in listings of fire-rated assemblies. (see Section 3, Table 3-1 in this manual.) The 15-minute-finish-rated thermal barrier shall be permitted to be used for combustible or noncombustible walls, floors, and ceilings.

*Exception: Where a fire sprinkler system(s) is installed in accordance with NFPA 13-1999, Standard for the Installation of Sprinkler Systems, on all floors, ENT is permitted to be used within walls, floors, and ceilings, exposed or concealed, in buildings exceeding three floors above grade.*

Reference NEC Section 300.4 Protection Against Physical Damage: Where subject to physical damage, conductors shall be adequately protected.

- (a) Cables and Raceways Through Wood Members.

**Bored Holes.** In both existing and concealed locations, where a cable or raceway-type wiring method is installed through bored holes in joists, rafters, or wood members, holes shall be bored so that the edge of the hole is not less than  $1\frac{1}{4}$  inch (31.8 mm) from the nearest edge of the wood member. Where this distance cannot be maintained, the cable or raceway shall be protected from penetration by screws or nails by a steel plate or bushing, at least  $\frac{1}{16}$  inch (1.59 mm) thick, and of appropriate length and width installed to cover the area of the wiring.

*Exception: Steel plates shall not be required to protect rigid metal conduit, intermediate metal conduit, rigid nonmetallic conduit, or electrical metallic tubing.*

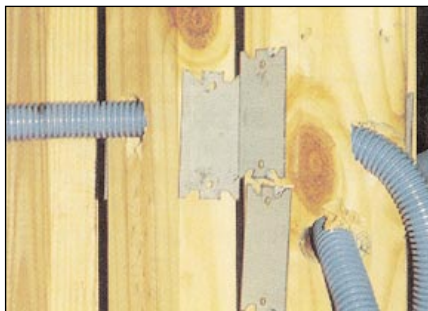

# Questions about ENT

## 1. WHAT IS THE FINISH RATING WHERE ENT IS INSTALLED?

As previously stated in this manual, when ENT is run through studs and the wall, construction provides at least a 15 minute finish rating by using materials shown in the following chart.

<b>FINISH RATINGS OF WALLS</b>	
<b>Material</b>	<b>Finish Rating Min.</b>
Fireboard, 1/2" thick with 1/2" 112,112 Gypsum sand plaster	15
Gypsum wallboard, 1/2" thick	15
Gypsum wallboard, 5/8" thick	20
Laminated wallboard, 3/8", 1/2" and 5/8" thick	28-60

*From National Bureau of Standards, BMS-92*

**Table 3-1**

## 2. WHAT HOLE SIZES DO I NEED FOR ENT RUNS THROUGH STUDS OR JOISTS?

The absolute minimum size of holes needed are as follows:

<b>ENT (trade size)</b>	<b>Hole (inches)</b>
1/2	1*
3/4	1 1/8
1	1 1/2
1 1/4	1 3/4
1 1/2	2
2	2 1/2

*\*This is the only size ENT that can be drilled in the center of a standard 2 x 4 inch wood stud and maintain 1 1/4 inch from each edge.*

## 3. HOW DO I INSTALL 3/4 INCH ENT AND OTHER LARGER SIZES OF ENT IN STUDS OR JOISTS?

For 3/4 inch ENT, start your 1 1/8 inch hole 1 1/4 inch from the edge and cover the other side of the stud with a 1/16 inch thick steel plate moved over the hole where it is less than 1 1/4 inch from the other end of the stud (see Section 300.4(A)(1), Section 10 of this manual.)

For 1 inch through 2 inch ENT, it should not be installed in a 2 × 4 inch studded wall since it will not meet minimum code requirements. Our suggestion is that 1 inch through 2 inch ENT be installed in a 2 × 6 inch studded wall only. This can be drilled in the center of a 2 × 6 inch stud.

#### **4. IS THERE A CONCERN WITH THE INSTALLATION OF ENT PARALLEL TO STUDS OR JOISTS? WHAT IS THE SUPPORT SPACING?**

- a. No. As long as the ENT is not closer than 1<sup>1</sup>/<sub>4</sub> inches from the edge where nails or screws are likely to penetrate (see Section 300.4(D), Section 10 of this manual).
- b. For supporting such runs, use as Carlon Snap Straps, nonmetallic clamps for 1/2 inch through 2 inch sizes, or nail straps for 1/2 inch through 1 inch sizes. Supports must be 3 feet from each termination in a box or panel and 3 feet on center thereafter (see NEC Section 362.30, Section 10 of this manual.)

#### **5. WHAT IS 1 1/4 INCH THROUGH 2 INCH ENT USED FOR?**

The larger sizes of ENT are intended to be used for system feeders, feeders and branch circuit home runs. See Sections 4, 5 and 6 of this manual for more applications of the larger sizes.

#### **6. WHAT IF THE STUD JOIST IS NOTCHED, NOT DRILLED. HOW IS THE ENT PROTECTED?**

Check the job specifications first, make sure they allow notching. After notching the wood building member and installing the ENT, protect it with a 1/16 inch thick steel plate to protect the ENT from nails or screws (ref. NEC Section 300.4(A)(2), see Section 10 of this manual.)

#### **7. DO I USE THE HOLES ALREADY MADE IN THE METAL STUDS FOR INSTALLING ENT?**

Yes. When installing ENT through holes in metal studs, it must be pulled briskly for ease of installation, otherwise the corrugations in the ENT will have a tendency to hang-up. You should be careful not to pull a stud out of position. For a short length of ENT, it can be passed through the opening at a steep angle through the steel stud to avoid a hang-up.

## 8. WHAT IF I NEED TO RUN THROUGH THE STEEL STUD AND THERE ARE NO HOLES?

Carlton suggests purchasing a stud punch and put the holes where you need them.

## 9. WHAT IF A BUILDING THAT IS SEVEN FLOORS HIGH REQUIRES THE USE OF ENT, BUT THE NEC SAYS IT SHALL NOT EXCEED THREE FLOORS ABOVE GRADE?

Section 362.10(1) covers exposed work only. "On or attached to the surface..." There is a three floor limit for exposed work. Section 362.10(2) covers concealed work. "Concealed within walls, floors and ceilings...which have at least a 15 minute finish rating." ***There is no height limit for the installation of concealed ENT.***

## 10. IN A MULTI-TENANT BUILDING, THERE IS AN AUDITORIUM SEATING 110 PEOPLE AND TWO SMALL THEATERS, CAN I USE ENT?

Yes, in 2 inches of concrete. Refer to Article 518 – Places of Assembly, and Article 520 – Theaters and similar locations.

## 11. CAN I USE ENT FOR RISERS FOR COMMUNICATION, FIRE ALARM AND POWER?

Yes. Risers up to 2 inches may be installed as long as the supports for ENT (3 feet on center) are not exceeded and the wires within the ENT are supported in accordance with NEC Section 300.19.



***ENT installed in metal stud wall***

## 12. WHILE INSTALLING A RISER THROUGH A FIRE-RESISTIVE FLOOR, ARE THERE ANY SEALING REQUIREMENTS?

Yes. All openings must be fire-stopped (see NEC Section 300.21, Section 10 of this manual).

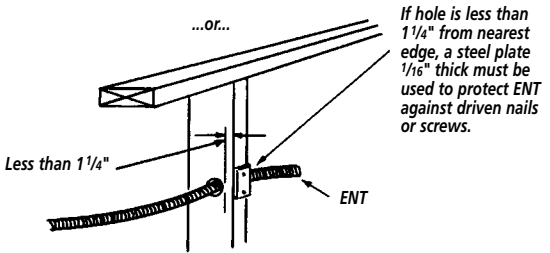
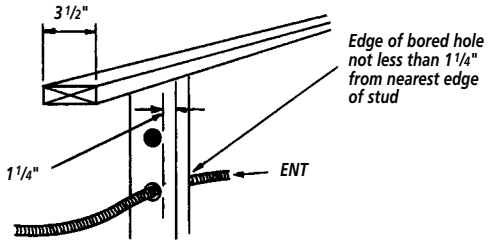

## Holes through Wood Studs

Ref. NEC Section 300.4(A)

(Illustration 3-1)

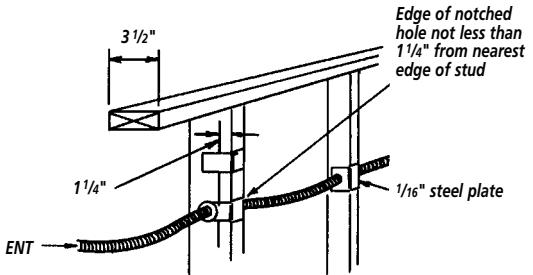

## Notches in Wood Stud

Section 300.4(A). Clearance for ENT through wood studs.

Ref. NEC Section 300.4(A)(2)

(Illustration 3-2)

### **13. CAN ENT BE “PRE-WIRED” PRIOR TO INSTALLATION?**

Yes, per Section 300.18(A) and 362.10(8), 1/2 inch through 1 inch ENT, as a listed manufactured pre-wired assembly, is now recognized by the NEC as an acceptable wiring method. Pre-wired ENT is required to be assembled by the listed manufacturer and cannot be field assembled. A special cutting tool is required to be used to prevent damage to the conductors during the cutting of the assembly.

### **14. CAN ENT BE PLACED ON THE GROUND BEFORE POURING CONCRETE?**

Yes, per Section 362.10(6), the NEC allows ENT to be placed directly on sand or approved screenings prior to “embedding” the ENT in concrete.

### **15. WILL THE NEC ALLOW ENT TO BE USED IN RV’S, TRAILERS AND PARKS?**

Yes, per Section 551.47(A), ENT is now recognized by the NEC as an acceptable wiring method when passing through the centers of the wide side of 2 inch by 4 inch wood studs for Recreational Vehicles, Recreational Vehicle Parks and Park Trailers.



# Section 4

---

## Masonry Construction

Reference NEC Section 362.10 Uses Permitted:

The use of electrical nonmetallic tubing and fittings shall be permitted:

- (1) In any building not exceeding three floors above grade
  - a. For exposed work, where not prohibited by 362.12(10)
  - b. Concealed within walls, floors, and ceilings.
- (2) In any building exceeding three floors above grade, ENT shall be concealed within walls, floors, and ceilings where the walls, floors, and ceilings provide a thermal barrier of material that has at least a 15 minute finish rating as identified in listings of fire-rated assemblies. (see Section 3, Table 3-1 in this manual). The 15-minute-finish-rated thermal barrier shall be permitted to be used for combustible or noncombustible walls, floors, and ceilings.

*Exception: Where a fire sprinkler system(s) is installed in accordance with NFPA 13-1999, Standard for the Installation of Sprinkler Systems, on all floors, ENT is permitted to be used within walls, floors, and ceilings, exposed or concealed, in buildings exceeding three floors above grade.*

## Questions About ENT

### 1. CAN I USE CARLON ENT IN BLOCK WALL?

Yes. The installation of ENT in block walls requires less lifting of blocks by the mason. The pliable construction of ENT allows for bending and threading through the block cavity at a convenient work height.

### 2. WHAT ARE THE ADVANTAGES OF USING RIGID CONDUIT VS. ENT IN A MASONRY WALL?

There are none. Read on:

- a. If the receptacles are fed from overhead it provides a length of conduit from the roughed-in receptacle to

the ceiling, thus causing the mason to wait while the electrician completes each conduit extension.

- b. Installing a box with 4 - 5 feet length of rigid conduit then returning when the mason is up to the height of the conduit with another piece of rigid conduit with a coupling to attach, then again returning before the last course is installed to install the 90° elbow.

**Working with other trades is easier when using ENT rather than coming back at least twice to finish your work.**

### **3. BETWEEN A PANEL AND A BOX, HOW MANY BENDS CAN I MAKE IN A LENGTH OF ENT?**

You are allowed four 90° bends or the equivalent of 360° total (see NEC Section 362.26, Section 10 of this manual.)

### **4. SINCE ENT IS MADE WITH A NONCONDUCTING MATERIAL, DO I NEED AN EQUIPMENT GROUND?**

Where equipment grounding is required, a separate equipment grounding conductor shall be installed in the raceway (see NEC Article 250, for ground conductor size see Section 9, Table 9-8 of this manual.)

# Section 5

---

## Exposed Construction

Reference NEC Section 362.10: The use of electrical nonmetallic tubing and fittings shall be permitted:

- (1) In any building not exceeding three floors above grade.
  - a. For exposed work, where not prohibited by 362.12(10).
  - b. Concealed within walls, floors, and ceilings.
- (2) In any building exceeding three floors above grade, ENT shall be concealed within walls, floors, and ceilings where the walls, floors, and ceilings provide a thermal barrier of material that has at least a 15-minute finish rating as identified in listings of fire-rated assemblies. The 15-minute-finish-rated thermal barrier shall be permitted to be used for combustible or noncombustible walls, floors, and ceilings.

## Questions About ENT

### 1. WHAT DOES “NOT SUBJECT TO PHYSICAL DAMAGE” MEAN?

It means the normal activity in the area where the installation is located is such that it would not damage the installation. In locations where ENT would be exposed to physical damage, guards must be installed to provide protection and be arranged to prevent such damage.

### 2. WHERE CAN I RUN ENT EXPOSED?

You can run ENT exposed in commercial buildings, warehouses, self storage buildings, condominiums, apartments, hotel/motel complexes, schools, and other structures where the building is not over three floors above grade.

### 3. EXACTLY WHAT IS EXPOSED CONSTRUCTION?

Exposed construction is where you can see the ENT and boxes when construction is complete, i.e., attic crawl spaces where ENT is fastened to studs, and in warehouses where ENT is fastened to steel trusses to feed hi-bay fixtures.

### 4. ARE THERE ANY SPECIAL REQUIREMENTS WHEN RUNNING FROM A PANEL INTO A FREEZER?

Yes. The conduit must be sealed to prevent air circulation (see NEC Article 300.7, Section 10 of this manual.)

## 5. CAN I USE ENT IN A CABLE TRAY?

Yes (see NEC Section 392.3 (A), Section 10 of this manual.)

## 6. I WILL BE LIGHTING A LOADING DOCK OVERHEAD. CAN I USE ENT TO CONNECT THE OVERHEAD LIGHTS EXPOSED IN THE CANOPY?

Yes. This is considered a partially protected damp location (refer to NEC Article 100 – Location.)

## 7. CAN I USE ENT TO CONNECT ITEMS IN HAZARDOUS LOCATIONS?

Yes. But it is limited to intrinsically safe systems (see NEC Section 504.20 and 505.15).

## 8. CAN I USE ENT FOR CONNECTION OF ITEMS LOCATED IN AN AREA HAVING A CORROSIVE ATMOSPHERE?

Yes. See Table 9-9, Section 9 of this manual (ref. NEC Section 300.6, Section 10 of this manual.)

Reference NEC Section 362.12(7): In exposed locations, except as permitted by Sections 362.10(1), 362.10(5) and 362.10(7).

Section 362.12(7) prohibits the exposed use of ENT but exempts locations covered in Section 362.10(7) (wet locations) in addition to the previously allowed low-rise buildings and over suspended ceilings with the required fire-finish rating.

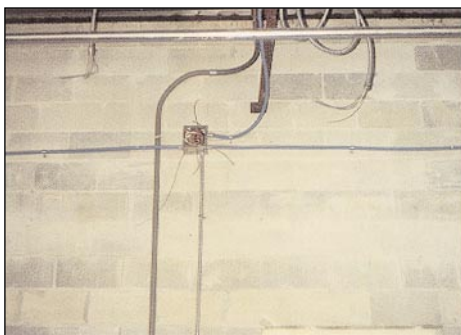

## 9. WHAT IS THE DEFINITION OF A FIRST FLOOR?

For the purpose of this article, the first floor of a building shall be that floor that has 50 percent or more of the exterior wall surface area level with or above finished grade. One additional level that is the first level and not designed for human habitation and used only for vehicle parking, storage, or similar use shall be permitted.

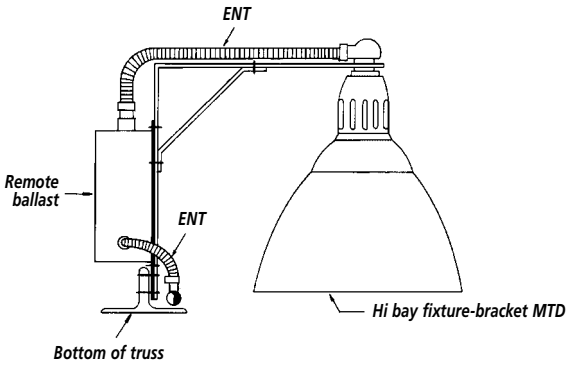

**Exposed ENT Industrial Application**  
(Illustration 5-1)

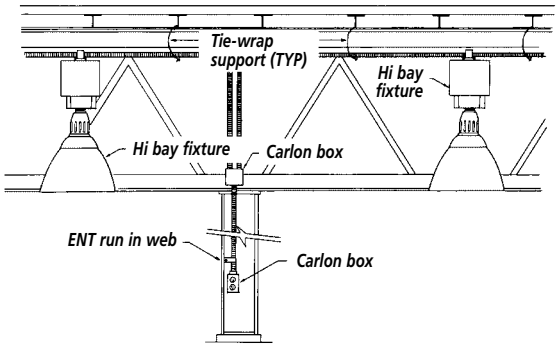

**Exposed ENT Industrial Application**  
(Illustration 5-2)

Clamp or other support  
must be within 3' of  
any box, cabinet or  
other conduit  
termination

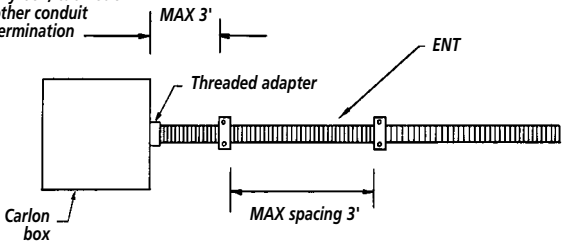

**Support Spacing for ENT**

Ref. NEC Section 362.30. See Section 10 of this manual  
(Illustration 5-3)

# Section 6

---

## Above a suspended ceiling

Reference NEC Section 362.10(5) Permitted Uses:

- (5) Above suspended ceilings where the suspended ceilings provide a thermal barrier of material that has at least a 15 minute finish rating as identified in listings of fire-rated assemblies, except as permitted in Section 362.10(1)(a).

*Exception: Where a fire sprinkler system(s) is installed in accordance with NFPA 13-1999, Standard for the Installation of Sprinkler Systems, on all floors, ENT is permitted to be used within walls, floors, and ceilings, exposed or concealed, in buildings exceeding three floors above grade.*

## Questions About ENT

### 1. CAN I USE ENT FOR FIXTURE TAILS?

It depends. If the ENT fixture tail is used in non-air-handling plenum, it is permitted (see NEC Section 410.14 and 410.67(C)). If the ENT would be used as a fixture tail in an air-handling plenum, the answer is NO. (ref. NEC Section 300.22). See illustration 6-1 and 6-2 in this section.

### 2. CAN I USE ENT FOR BRANCH LIGHTING AND POWER CIRCUITS RUN ABOVE A SUSPENDED CEILING?

Yes, provided the area, above the lay-in ceiling, is not used as an air-handling space.

### 3. WHAT IF THE INSPECTOR SAYS THAT THE CEILING INSTALLATION IS EXPOSED AND IS NOT ALLOWED?

This is not an exposed condition. Refer to the NEC Article 100 – Definitions – Accessible: Capable of being removed or exposed without damaging the building structure or finish, or not being permanently closed by the structure or finish of the building.

### 4. I AM INSTALLING ENT IN A NON-AIR-HANDLING PLENUM. THE ENT WILL BE SUPPORTED ON WOODEN JOISTS. WHERE DO I INSTALL THE ENT ON THE JOIST?

Refer to Section 3 of this manual (questions 2, 3 and 4). It refers to the hole locations in the joist or running parallel with the joist.

## 5. WHAT IF I AM RUNNING ENT, THEN FIND I MUST RUN THROUGH AN AIR-HANDLING SPACE?

You run the ENT to a point before entering the air-handling plenum, change to metal conduit, run through the air-handling space with the metal conduit, and change to ENT for the balance of the run (see NEC Section 300.22 (A) through (D)).

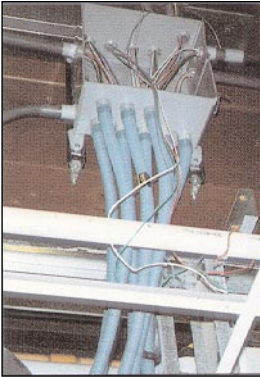

*ENT above a suspended ceiling for receptacle drops*

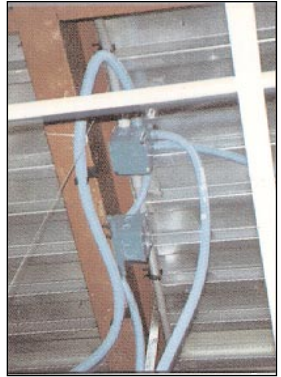

*ENT and Carlon boxes roughed-in for fixture whips*

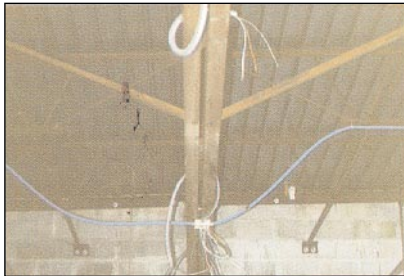

*ENT feed fixture roughed-in*



*ENT above a suspended ceiling (ENT fixture whips)*

No ENT or PVC can be installed in an air-handling plenum

See Sections 300.22 (A)(B)(C)

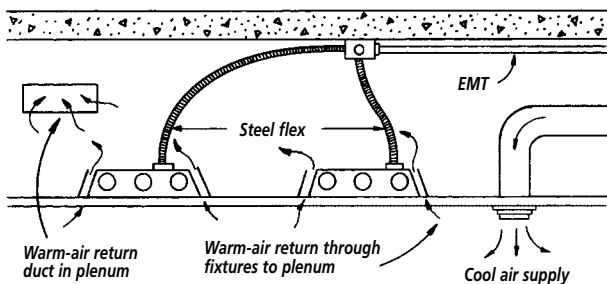

## Air Handling Plenum

(Illustration 6-1)

ENT may be used as fixture flex tails above a ceiling only where that space is not used for air handling or environmental air

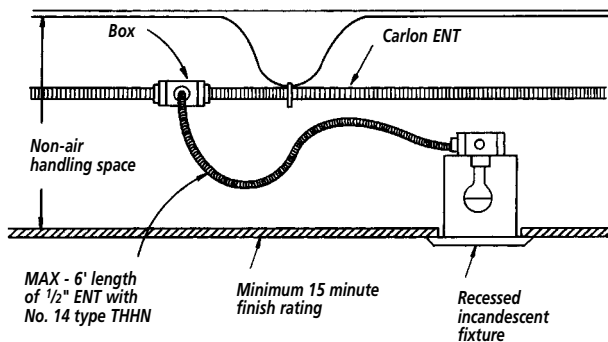

## Air Handling Plenum

(Illustration 6-1)

### 6. CAN ENT BE USED IN A RAISED FLOOR?

Yes. Refer to Sections 300.22 (D) and 645.5 (D).



# Section 7

---

## Boxes and Supports

Reference NEC Article 314 Outlet, Device, Pull and Junction Boxes, Conduit Bodies, Fittings, and Manholes.

314.1. Scope. This article covers the installation and use of all boxes and conduit bodies used as outlet, junction, or pull boxes, depending on their use, and manholes and other electric enclosures intended for personnel entry. Cast, sheet metal, nonmetallic, and other boxes such as FS, FD, and larger boxes are not classified as conduit bodies. This article also includes installation requirements for fittings used to join raceways and to connect raceways and cables to boxes and conduit bodies.

314.3. Nonmetallic Boxes. Nonmetallic boxes shall be permitted only with open wiring on insulators, concealed knob-and-tube wiring, cabled wiring methods with entirely non-metallic sheaths, flexible cords, and nonmetallic raceways.

## Questions about ENT

### 1. CAN I SUPPORT A 20 POUND FIXTURE FROM A CARLON NONMETALLIC CEILING BOX THAT IS FIRMLY SUPPORTED FROM THE STRUCTURE?

Yes. See NEC Sections 314.33 and 314.27. Maximum fixture weight for a Carlon ceiling box listed for fixture support is 50 pounds.

### 2. WHAT SPECIAL REQUIREMENTS MUST I ADHERE TO FOR THE INSTALLATION OF A CARLON NON-METALLIC BOX IN A FIRE RESISTIVE WALL?

- a. Precautions must be taken to assure that the wall openings are not oversized. The clearance between the edge of the box and the wall should not exceed 1/8 inch (see NEC Section 314.20).
- b. If nonmetallic boxes are installed on opposite sides of the fire resistive wall assembly without the use of mineral wool batt insulation, must be separated by a horizontal distance of 24 inches. Mineral wool batt can also be used to achieve a 7 inch separation. Putty pads

can be used in place of the insulation to achieve a zero separation without being back to back.

- c. Openings around electrical penetrations through fire-resistive walls, penetrations...shall be fire stopped using approved methods to maintain the fire-resistive rating.
- d. The total surface area of the Carlon boxes in walls or ceilings on one side of the fire-resistive assembly cannot exceed 100 square inches for any 100 square feet of wall or ceiling area.

### 3. WHAT ABOUT CUBIC INCH CAPACITY OF CARLON'S BOXES?

For cubic inch capacity of Carlon boxes see Table 7-1 in this manual; for maximum number of conductors see NEC Section 314.6, Section 10 in this manual; for FS and FD boxes, see Carlon's rigid nonmetallic conduit, fittings and accessories catalog.

### 4. WHAT ABOUT THE SUPPORTS OF BOXES?

They shall be rigidly and securely fastened. See NEC Section 314.23.

## Application of Wall Boxes

Carlon series A58 & A52 ENT boxes are listed for use as switch/outlet boxes, thus they are marked "for use in walls only." This marking is dictated by UL.

Contractors have found that the ENT wall boxes have an application as a junction box in a ceiling area, not used for environmental air, and where the ENT and the box is not subject to physical damage, and where the box clearly cannot be used for a light fixture. Some inspectors have questioned this use because of the marking on the box.

Since the ENT wall box is a thicker walled box than the ENT ceiling box, Carlon supports the use of the wall box as a ceiling junction box if the conditions as stated above are followed. Inspector approval should be obtained prior to installation.



**Wall Box Installation.**

## Cubic Inch Capacity of Carlon Boxes

Box Size	Cubic Inches Per Box
2 1/2" Deep Mud Box (1/2" KO's)	26
2 1/2" Deep Mud Box (3/4" KO's)	26
4" Deep Mud Box (1/2" KO's)	44
4" Deep Mud Box (3/4" KO's)	44
4" Deep Mud Box (1" KO's)	44
6" Deep Mud Box	63
1 Gang Switch Box 1 1/2" D	16
2 Gang Switch Box 1 1/2" D	20
2 Gang Switch Box 2 3/8" D	30.3
1 Gang Plaster Ring 1/2" Rise	3.5
1 Gang Plaster Ring 5/8" Rise	4.2
1 Gang Plaster Ring 3/4" Rise	5.0
1 Gang Plaster Ring 1" Rise	6.6
1 Gang Plaster Ring 1 1/4" Rise	8.1
2 Gang Plaster Ring 1/2" Rise	6.1
2 Gang Plaster Ring 5/8" Rise	7.4
2 Gang Plaster Ring 3/4" Rise	8.8
2 1/8" Ceiling Box 1 1/2" D x 4" D (All Types)	20.5
4" Round Plaster Ring 1/2"	3.2
4" Round Plaster Ring 5/8"	4.0

**Table 7-1**

*NOTE: To obtain additional cubic inches for your particular situation, you can install a plaster ring, add the cubic inches of a Carlon box and plaster ring for total cubic inches, i.e.:*

Two Gang Box	20.0 cu.in.
5/8" Plaster Ring	7.4 cu.in.
TOTAL	27.4 cu.in.

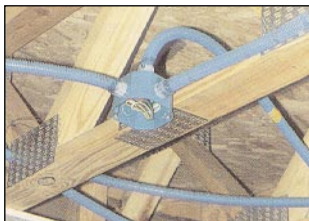

**Carlon Ceiling Box and ENT roughed above a ceiling.**

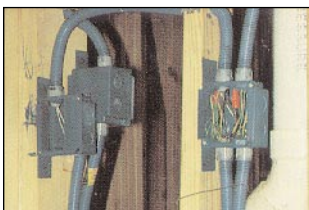

**Carlon Switch Boxes roughed-in for switches and receptacles.**



***ENT terminated on a Switch Box ready for a poured concrete wall. (This is a Tunnel Form Method).***



***Tunnel Forming project  
Carlson ENT terminated  
in metal\* boxes  
roughed-in for a poured  
concrete wall***



***Carlson ENT roughed-in a deck  
(between layers of rebar)  
ready for a concrete pour  
(tunnel form).***

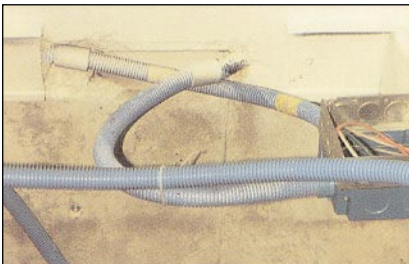

***ENT extended from stub down in wall  
and terminated in a Carlson Switch Box  
with a metal\* box extension.***

***\* Refer to NEC Article 250 for grounding requirements of steel boxes. Size of ground wire shall be as indicated in Table 9-7, Section 9 of this manual.***

# Section 8

---

## Field Expediency and Tips



***Use an inexpensive shelf bracket nailed to the plywood deck to support ENT stub ups.***

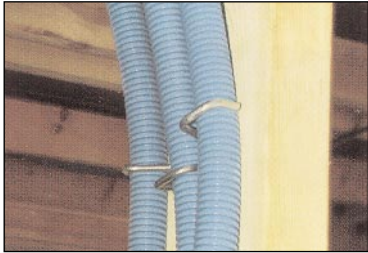

***This installation is not in accordance with Article 300 of the NEC because ENT must be 1 1/4" from edge of stud, see NEC Section 300.4(D), Section 10 of manual.***



***Truck set up with reel stands for the payout of ENT on job site.***



***Reel set up on a floor to payout ENT for convenience of the installer.***

***NOTE: Remember to always payout ENT as it lays on the reel for ease of installation.***



***Save more time! After roughing in for two rooms to determine the best ENT routing. Pre-fab your short runs complete with the boxes, tie them together, identify them and take them to the site when you are ready for installation.***



***Pre-fab longer runs complete with stub ups to be placed in concrete.***

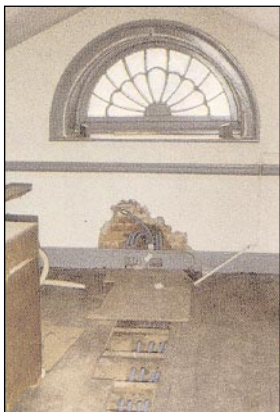

***Remodeling: Run ENT in floors and walls with a minimum disruption of existing building while completing the job with minimum expense.***



***An outlet can be added after the wall is poured. Channel the wall, install ENT and the box, furr out and finish. Because ENT is pliable, it will follow the contour of the channel.***

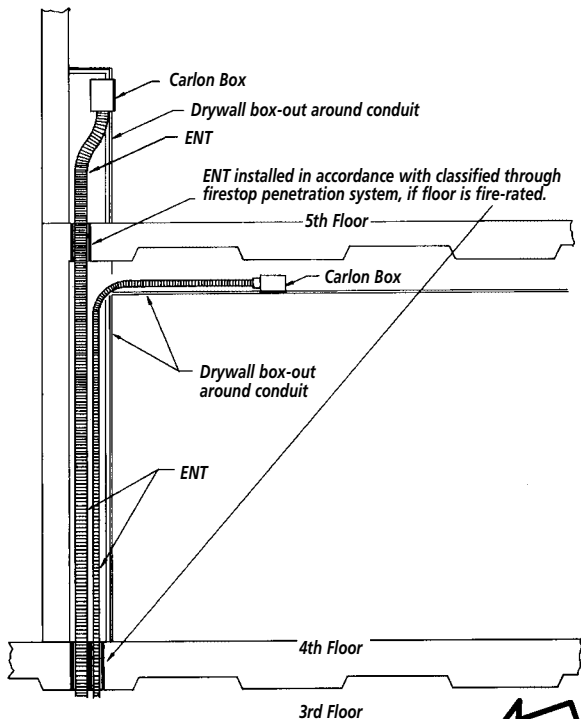

## To Make Exposed ENT Concealed Above The 3rd Floor

(Illustration 8-1)

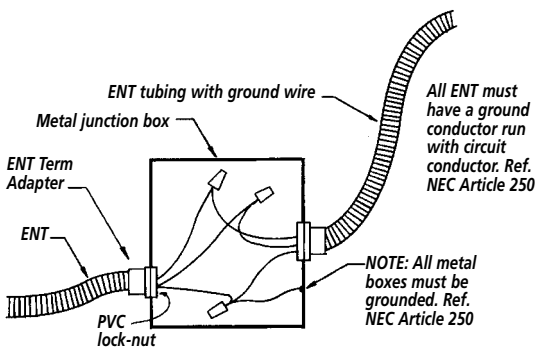

## Metal Box Grounded

(Illustration 8-2)



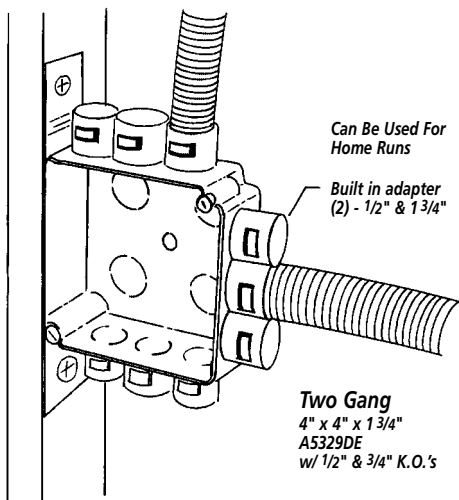

## ENT Box with Adapters

(Illustration 8-3)

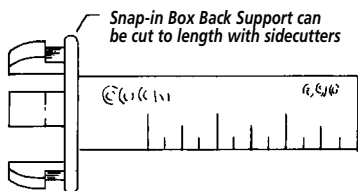

## Box Back Wall Support

(Illustration 8-4)

# Section 9

---

## Tables, Charts, Etc.

### Tubing & Conduit Data Comparisons

Table 9-1

<b>Flex Plus® Blue™ ENT</b>			
Size	O.D.	I.D.	WT/FT
1/2	.840	.560	.11
3/4	1.050	.760	.14
1	1.315	1.00	.22
1 1/4	1.660	1.402	.19
1 1/2	1.900	1.554	.27
2	2.375	2.030	.32

Table 9-2

<b>SCHEDULE 40 RIGID PVC CONDUIT</b>			
Size	O.D.	I.D.	WT/FT
1/2	.840	.622	.18
3/4	1.050	.824	.23
1	1.315	1.049	.35
1 1/4	1.660	1.380	.48
1 1/2	1.900	1.610	.57
2	2.375	2.067	.76

Table 9-3

<b>SCHEDULE 80 RIGID PVC CONDUIT</b>			
Size	O.D.	I.D.	WT/FT
1/2	.840	.546	.21
3/4	1.050	.742	.29
1	1.315	.957	.43
1 1/4	1.660	1.278	.60
1 1/2	1.900	1.50	.72
2	2.375	1.939	1.00

## Tubing & Conduit Data Comparisons

Table 9-4

<b>EMT (Electrical Metallic Tubing)</b>			
Size	O.D.	I.D.	WT/FT
1/2	.706	.666	.29
3/4	.922	.876	.44
1	1.163	1.109	.64
1 1/4	1.510	1.449	.95
1 1/2	1.740	1.679	1.10
2	2.197	2.130	1.40

Table 9-5

<b>RIGID GALV. CONDUIT</b>			
Size	O.D.	I.D.	WT/FT
1/2	.840	.662	.85
3/4	1.050	.824	1.13
1	1.315	1.049	1.65
1 1/4	1.660	1.380	2.28
1 1/2	1.900	1.610	2.73
2	2.375	2.067	3.63

## Center-To-Center Spacing For ENT in Boxes or Templates

Table 9-6

<b>ENT TUBING SPACINGS</b>						
ENT Size	1/2	3/4	1	1 1/4	1 1/2	2
1/2	1 3/16 <b>1 3/8</b>					
3/4	1 5/16 <b>1 1/2</b>	1 7/16 <b>1 5/8</b>				
1	1 1/2 <b>1 3/4</b>	1 5/8 <b>1 7/8</b>	1 3/4 <b>2</b>			
1 1/4	1 3/4 <b>2</b>	1 7/8 <b>2 1/8</b>	2 <b>2 1/4</b>	2 1/4 <b>2 1/2</b>		
1 1/2	1 15/16 <b>2 1/8</b>	2 1/16 <b>2 1/4</b>	2 3/16 <b>2 3/8</b>	2 7/16 <b>2 5/8</b>	2 9/16 <b>2 3/4</b>	
2	2 3/16 <b>2 3/8</b>	2 5/16 <b>2 1/2</b>	2 1/2 <b>2 3/4</b>	2 3/4 <b>3</b>	2 7/8 <b>3 1/4</b>	3 1/8 <b>3 3/8</b>

Light figures for each size ENT are minimum spacing in inches.

Bold figures for each size ENT are recommended spacing in inches.

## Minimum Number of Conductors in Conduit or Tubing

**Table 9-7**

Type	Conductor Size (AWG/kcmil)	ENT Trade Size (in.)					
		1/2	3/4	1	1 1/4	1 1/2	2
THHN, THWN, THWN-2	14	10	18	32	58	80	132
	12	7	13	23	42	58	96
	10	4	8	15	26	36	60
	8	2	5	8	15	21	35
	6	1	3	6	11	15	25
	4	1	1	4	7	9	15
	3	1	1	3	5	8	13
	2	1	1	2	5	6	11
	1	1	1	1	3	5	8
	1/0	0	1	1	3	4	7
	2/0	0	1	1	2	3	5
	3/0	0	1	1	1	3	4
	4/0	0	0	1	1	2	4
	250	0	0	1	1	1	3
	300	0	0	1	1	1	2
	350	0	0	0	1	1	2
	400	0	0	0	1	1	1
	500	0	0	0	1	1	1
	600	0	0	0	1	1	1
	700	0	0	0	0	1	1
750	0	0	0	0	1	1	
800	0	0	0	0	1	1	
900	0	0	0	0	1	1	
1000	0	0	0	0	0	1	
FEP, FEPB, PFA, PFAH, TFE	14	10	18	31	56	77	128
	12	7	13	23	41	56	93
	10	5	9	16	29	40	67
	8	3	5	9	17	23	38
	6	1	4	6	12	16	27
	4	1	2	4	8	11	19
	3	1	1	4	7	9	16
2	1	1	3	5	8	13	
PFA, PFAH, TFE	1	1	1	1	4	5	9
PFA, PFAH, TFE, Z	1/0	0	1	1	3	4	7
	2/0	0	1	1	2	4	6
	3/0	0	1	1	1	3	5
	4/0	0	1	1	1	2	4
Z	14	12	22	38	68	93	154
	12	8	15	27	48	66	109
	10	5	9	16	29	40	67
	8	3	6	10	18	25	42
	6	1	4	7	13	18	30
	4	1	3	5	9	12	20
	3	1	1	3	6	9	15
	2	1	1	3	5	7	12
1	1	1	2	4	6	10	
XHH, XHHW, ZHHW-2, ZW	14	7	13	22	40	55	92
	12	5	10	17	31	42	71
	10	4	7	13	23	32	52
	8	1	4	7	13	17	29
	6	1	3	5	9	13	21
	4	1	1	4	7	9	15
	3	1	1	3	6	8	13
	2	1	1	2	5	6	11

## Minimum Size Equipment Grounding Conductors for Grounding Raceway & Equipment

Table 9-8

Rating or setting of automatic overcurrent device in circuit ahead of equipment conduit, etc., not exceeding (amperes)	Size	
	Copper Wire No.	Aluminum or Copper-Clad Aluminum Wire No.*
15	14	12
20	12	10
30	10	8
40	10	8
60	10	8
100	8	6
200	6	4
300	4	2
400	3	1
500	2	1/0
600	1	2/0
800	1/0	3/0
1000	2/0	4/0
1200	3/0	250 kcmil
1600	4/0	350 kcmil
2000	250 kcmil	400 kcmil
2500	350 kcmil	600 kcmil
3000	400 kcmil	600 kcmil
4000	500 kcmil	800 kcmil
5000	700 kcmil	1200 kcmil
6000	800 kcmil	1200 kcmil

\*See installation restrictions in Section 250.122

# PVC Chemicals Resistance chart

Table 9-9

<b>ACIDS</b>	<b>C</b>	<b>H</b>	<b>GASES</b>	<b>C</b>	<b>H</b>
Acetic, 10%	F	N	Chlorine wet	E	E
Acetic, glacial	N	N	Chlorine dry	E	E
Benzene sulfonic	E	E	Sulfur dioxide wet	E	E
Benzonic	E	E	Sulfur dioxide dry	E	E
Boric	E	E	Hydrogen sulfide	E	E
Butyric	G	N	<b>ORGANIC MATERIALS</b>		
Chloroacetic	F	N	Acetone	N	N
Chromic, 10%	E	G	Alcohol, methyl, ethyl	E	E
Chromic, 50%	G	F	Aniline	N	N
Citric	E	E	Benzene	P	N
Fatty Acids (C <sub>6</sub> & up)	E	F	CCl <sub>4</sub>	N	N
Fluosilicic	E	E	Chloroform	N	N
Formic	F	N	Ethyl acetate	N	N
Hydrobromic	E	E	Formaldehyde, 37%	E	E
Hydrochloric	E	E	Gasoline	E	F
Hydrocyanic	E	E	Phenol	N	N
Hydrofluoric	E	E	Refinery crudes	E	G
Hypochlorous	E	E	Trichloroethylene	N	N
Lactic	E	E	<b>PAPER MILL APPLICATIONS</b>		
Maleic	G	F	Kraft liquor	E	E
Nitric, 5%	E	E	Black liquor	E	E
Nitric, 20%	E	F	Green liquor	E	E
Nitric, 40%	G	N	White liquor	E	E
Oleic	E	F	Sulfite liquor	E	E
Oxalic	E	E	Chlorite bleach	E	G
Perchloric	E	E	Alum	E	E
Phosphoric	E	E	<b>PHOTOGRAPHIC INDUSTRY</b>		
Picric	P	N	Developers	E	G
Stearic	E	F	Silver Nitrate		
Sulfuric, 50%	E	E	General use	E	G
Sulfuric, 70%	E	G	<b>FERTILIZER INDUSTRY</b>		
Sulfuric, 93%	G	N	General use	E	E
Oleum	P	N	<b>STEEL INDUSTRY</b>		
Mixed Acids, 28% HNO <sub>3</sub>	G	P	Sulfuric acid pickling	E	E
55% H <sub>2</sub> SO <sub>4</sub>			Hydrochloric acid	E	E
<b>ALKALIES</b>			H <sub>2</sub> SO <sub>4</sub> -HNO <sub>2</sub> pickling	E	E
Ammonium hydroxide	E	E	<b>TEXTILE INDUSTRY</b>		
Calcium hydroxide	E	E	General use	E	E
Potassium hydroxide	E	E	Hypochlorite bleach	E	G
Sodium hydroxide	E	E	<b>FOOD INDUSTRY</b>		
<b>ACID SALTS</b>			General use	E	E
Alum	E	E	Breweries	E	E
Ammonium, C1, NO <sub>3</sub> , SO <sub>4</sub>	E	E	Dairies	E	E
Copper, C1, SO <sub>4</sub>	E	E	<b>MISCELLANEOUS INDUSTRIES</b>		
Ferric, C1, SO <sub>4</sub>	E	E	Plating		
Nickel, C1, SO <sub>4</sub>	E	E	Petroleum	G	F
Stannic, C1	E	E	Tanning		
Zinc, C1, SO <sub>4</sub>	E	E	Oil & soap	E	E
<b>ALKALINE SALTS</b>			Water & sewer		
Barium sulfide	E	E	<b>RATINGS</b>		
Sodium bicarbonate	E	E	<b>E</b> – No attack		
Sodium carbonate	E	E	<b>G</b> – Appreciably no attack		
Sodium sulfide	E	E	<b>F</b> – Some attack, but usable in some instances		
Trisodium phosphate	E	E	<b>P</b> – Attacked, not recommended		
<b>NEUTRAL SALTS</b>			<b>N</b> – Rapidly attacked		
Calcium chloride	E	E	<b>C</b> – Cold – 75° F		
Calcium sulfate	E	E	<b>H</b> – Hot – 150° F		
Magnesium, C1, sulfate	E	E			
Potassium, C1, NO <sub>3</sub> , SO <sub>4</sub>	E	E			

The above chart is offered as a guide. Since conditions under usage are subject to wide variance, the chart is intended as a guide and should not be construed as a guarantee.

# Section 10

## Article 362 and Associated Articles

*Note: All references to the National Electrical Code are based on the 2002 edition.*

### **Article 362 – Electrical Nonmetallic Tubing: Type ENT**

#### **I. GENERAL**

**362.1 Scope.** This article covers the use, installation, and construction specifications for electrical nonmetallic tubing (ENT) and associated fittings.

#### **362.2 Definition. Electrical Nonmetallic Tubing (ENT).**

A nonmetallic pliable corrugated raceway of circular cross section with integral or associated couplings, connectors, and fittings for the installation of electric conductors. ENT is composed of a material that is resistant to moisture and chemical atmospheres and is flame retardant.

A pliable raceway is a raceway that can be bent by hand with a reasonable force, but without other assistance.

**362.6 Listing Requirements.** ENT and associated fittings shall be listed.

#### **II. INSTALLATION**

**362.10 Uses Permitted.** For the purpose of this article, the first floor of a building shall be that floor that has 50 percent or more of the exterior wall surface area level with or above finished grade. One additional level that is the first level and not designed for human habitation and used only for vehicle parking, storage, or similar use shall be permitted. The use of ENT and fittings shall be permitted in the following:

- (1) In any building not exceeding three floors above grade
  - a. For exposed work, where not prohibited by 362.12
  - b. Concealed within walls, floors, and ceilings
- (2) In any building exceeding three floors above grade, ENT shall be concealed within walls, floors, and ceilings where the walls, floors, and ceilings provide a thermal barrier of material that has at least a 15-minute finish rating as identified in listings of fire-rated assemblies. The 15-minute-finish-rated thermal barrier shall be permitted to be used for combustible or noncombustible walls, floors, and ceilings.



*Exception: Where a fire sprinkler system(s) is installed in accordance with NFPA 13-1999, Standard for the Installation of Sprinkler Systems, on all floors, ENT is permitted to be used within walls, floors, and ceilings, exposed or concealed, in buildings exceeding three floors above grade.*

*FPN: A finish rating is established for assemblies containing combustible (wood) supports. The finish rating is defined as the time at which the wood stud or wood joist reaches an average temperature rise of 121°C (250°F) or an individual temperature of 163°C (325°F) as measured on the plane of the wood nearest the fire. A finish rating is not intended to represent a rating for a membrane ceiling.*

- (3) In locations subject to severe corrosive influences as covered in 300.6 and where subject to chemicals for which the materials are specifically approved.
- (4) In concealed, dry, and damp locations not prohibited by 362.12.
- (5) Above suspended ceilings where the suspended ceilings provide a thermal barrier of material that has at least a 15-minute finish rating as identified in listings of fire-rated assemblies, except as permitted in 362.10(1)(a).

*Exception: Where a fire sprinkler system(s) is installed in accordance with NFPA 13-1999, Standard for the Installation of Sprinkler Systems, on all floors, ENT is permitted to be used within walls, floors, and ceilings, exposed or concealed, in buildings exceeding three floors above grade.*

- (6) Encased in poured concrete, or embedded in a concrete slab on grade where ENT is placed on sand or approved screenings, provided fittings identified for this purpose are used for connections.
- (7) For wet locations indoors as permitted in this section or in a concrete slab on or below grade, with fittings listed for the purpose.
- (8) Metric designator 16 through 27 (trade size 1/2 through 1) as listed manufactured prewired assembly.

*FPN: Extreme cold may cause some types of nonmetallic conduits to become brittle and therefore more susceptible to damage from physical contact.*

**362.12 Uses Not Permitted.** ENT shall not be used in the following:

- (1) In hazardous (classified) locations, except as permitted by 504.20 and 505.15(A)(1)
- (2) For the support of luminaires (fixtures) and other equipment
- (3) Where subject to ambient temperatures in excess of 50°C (122°F) unless listed otherwise
- (4) For conductors whose insulation temperature limitations would exceed those for which the tubing is listed
- (5) For direct earth burial
- (6) Where the voltage is over 600 volts
- (7) In exposed locations, except as permitted by 362.10(1), 362.10(5), and 362.10(7)
- (8) In theaters and similar locations, except as provided in articles 518 and 520
- (9) Where exposed to the direct rays of the sun, unless identified as sunlight resistant
- (10) Where subject to physical damage

**362.20 Size.**

- (A) **Minimum.** ENT smaller than metric designator 16 (trade size 1/2) shall not be used
- (B) **Maximum.** ENT larger than metric designator 53 (trade size 2) shall not be used.

*FPN: See 300.1(C) for the metric designators and trade sizes. These are for identification purposes only and do not relate to actual dimensions.*

**362.22 Number of Conductors.** The number of conductors shall not exceed that permitted by the percentage fill in Table 1, Chapter 9.

Cables shall be permitted to be installed where such use is permitted by the respective cable articles. The number of cables shall not exceed the allowable percentage fill specified in Table 1, Chapter 9.

**362.24 Bends – How Made.** Bends shall be made so that the tubing will not be damaged and that the internal diameter of the tubing will not be effectively reduced. Bends shall be permitted to be made manually without auxiliary equipment, and the radius of the curve to the centerline of such bends shall not be less than shown in Table 344.24 using the column "Other Bends."

**362.26 Bends – Number in One Run.** There shall not be more than the equivalent of four quarter bends (360 degrees total) between pull points, for example, conduit bodies and boxes.

**362.28 Trimming.** All cut ends shall be trimmed inside and outside to remove rough edges.

**362.30 Securing and Supporting.** ENT shall be installed as a complete system as provided in Article 300 and shall be securely fastened in place and supported in accordance with 362.30(A) and (B).

## **Article 100 – Definitions**

**Accessible:** (As applied to wiring methods.) Capable of being removed or exposed without damaging the building structure or finish, or not permanently closed in by the structure or finish of the building.

### **Location:**

Location, Damp: Locations protected from weather and not subject to saturation with water or other liquids but subject to moderate degrees of moisture. Examples of such locations include partially protected locations under canopies, marquees, roofed open porches, and like locations, and interior locations subject to moderate degrees of moisture, such as some basements, some barns, and some cold storage warehouses.

Location, Dry: A location not normally subject to dampness or wetness. A location classified as dry may be temporarily subject to dampness or wetness, as in the case of a building under construction.

Location, Wet: Installations under ground or in concrete slabs or masonry in direct contact with the earth; in locations subject to saturation with water or other liquids, such as vehicle washing areas; and in unprotected locations exposed to weather.

## **Article 300**

### **300.2 Limitations.**

**(A) Voltage.** Wiring methods specified in Chapter 3 shall be used for voltages 600 volts, nominal, or less where not specifically limited in some section of Chapter 3. They shall be permitted for voltages over 600 volts, nominal, where specifically permitted elsewhere in this Code.

**(B) Temperature.** Temperature limitation of conductors shall be in accordance with Section 310.10.

**300.4 Protection Against Physical Damage.** Where subject to physical damage, conductors shall be adequately protected.

**(A) Cables and Raceways Through Wood Members.**

- (1) Bored Holes. In both exposed and concealed locations, where a cable or raceway-type wiring method is installed through bored holes in joists, rafters, or wood members, holes shall be bored so that the edge of the hole is not less than 32 mm (1¼ in.) from the nearest edge of the wood member. Where this distance cannot be maintained, the cable or raceway shall be protected from penetration by screws or nails by a steel plate or bushing, at least 1.6 mm (1/16 in.) thick, and of appropriate length and width installed to cover the area of the wiring.

*Exception: Steel plates shall not be required to protect rigid metal conduit, intermediate metal conduit, rigid nonmetallic conduit, or electrical metallic tubing.*

- (2) Notches in Wood. Where there is no objection because of weakening the building structure, in both exposed and concealed locations, cables or raceways shall be permitted to be laid in notches in wood studs, joists, rafters, or other wood members where the cable or raceway at those points is protected against nails or screws by a steel plate at least 1.6 mm (1/16 in.) thick installed before the building finish is applied.

*Exception: Steel plates shall not be required to protect rigid metal conduit, intermediate metal conduit, rigid nonmetallic conduit, or electrical metallic tubing.*

**(B) Nonmetallic-Sheathed Cables and Electrical Nonmetallic Tubing Through Metal Framing Members.**

- (1) Nonmetallic-Sheathed Cable. In both exposed and concealed locations where nonmetallic-sheathed cables pass through either factory or field punched, cut, or drilled slots or holes in metal members, the cable shall be protected by listed bushings or grommets covering all metal edges and securely fastened in the opening prior to installation of the cable.

(2) **Nonmetallic-Sheathed Cable and Electrical Nonmetallic Tubing.** Where nails or screws are likely to penetrate nonmetallic-sheathed cable or electrical nonmetallic tubing, a steel sleeve, steel plate, or steel clip not less than 1.6 mm (1/16 in.) in thickness shall be used to protect the cable or tubing.

**(C) Cables Through Spaces Behind Panels Designed to Allow Access.** Cables or raceway-type wiring methods, installed behind panels designed to allow access, shall be supported according to their applicable articles.

**(D) Cables and Raceways Parallel to Framing Members.** In both exposed and concealed locations, where a cable- or raceway-type wiring method is installed parallel to framing members, such as joists, rafters, or studs, the cable or raceway shall be installed and supported so that the nearest outside surface of the cable or raceway is not less than 32 mm (1 1/4 in.) from the nearest edge of the framing member where nails or screws are likely to penetrate. Where this distance cannot be maintained, the cable or raceway shall be protected from penetration by nails or screws by a steel plate, sleeve, or equivalent at least 1.6 mm (1/16 in.) thick.

*Exception No. 1: Steel plates, sleeves, or the equivalent shall not be required to protect rigid metal conduit, intermediate metal conduit, rigid nonmetallic conduit, or electrical metallic tubing.*

*Exception No. 2: For concealed work in finished buildings, or finished panels for prefabricated buildings where such supporting is impracticable, it shall be permissible to fish the cables between access points.*

*Exception No. 3: Steel plates, sleeves, or the equivalent shall not be required to protect cables or raceways in mobile homes and recreational vehicles.*

**(E) Cables and Raceways Installed in Shallow Grooves.** Cable- or raceway-type wiring methods installed in a groove, to be covered by wallboard, siding, paneling, carpeting, or similar finish, shall be protected by 1.6 mm (1/16 in.) thick steel plate, sleeve, or equivalent or by not less than 32 mm (1 1/4 in.) free space for the full length of the groove in which the cable or raceway is installed.

*Exception: Steel plates, sleeves, or the equivalent shall not be required to protect rigid metal conduit, intermediate metal conduit, rigid nonmetallic conduit, or electrical metallic tubing.*

**(F) Insulated Fittings.** Where raceways containing ungrounded conductors 4 AWG or larger enter a cabinet, box enclosure, or raceway, the conductors shall be protected by a substantial fitting providing a smoothly rounded insulating surface, unless the conductors are separated from the fitting or raceway by substantial insulating material that is securely fastened in place.

*Exception: Where threaded hubs or bosses that are an integral part of a cabinet, box enclosure, or raceway provide a smoothly rounded or flared entry for conductors.*

Conduit bushings constructed wholly of insulating material shall not be used to secure a fitting or raceway. The insulating fitting or insulating material shall have a temperature rating not less than the insulation temperature rating of the installed conductors.

### **300.5 Underground Installations.**

**(G) Raceway Seals.** Conduits or raceways through which moisture may contact energized live parts shall be sealed or plugged at either or both ends.

*FPN: Presence of hazardous gasses or vapors may also necessitate sealing of underground conduits or raceways entering buildings.*

### **300.7 Raceways Exposed to Different Temperatures.**

**(A) Sealing.** Where portions of a cable, raceway, or sleeve are known to be subjected to different temperatures and where condensation is known to be a problem, as in cold storage areas of buildings or where passing from the interior to the exterior of a building, the raceway or sleeve shall be filled with an approved material to prevent the circulation of warm air to a colder section of the raceway or sleeve. An explosionproof seal shall not be required for this purpose.

### **300.18 Raceway Installations.**

**(A) Complete Runs.** Raceways, other than busways or exposed raceways having hinged or removable covers,

shall be installed complete between outlet, junction, or splicing points prior to the installation of conductors. Where required to facilitate the installation of utilization equipment, the raceway shall be permitted to be initially installed without a terminating connection at the equipment. Prewired raceway assemblies shall be permitted only where specifically permitted in this Code for the applicable wiring method.

### 300.19 Supporting Conductors in Vertical Raceways.

(A) **Spacing Intervals – Maximum.** Conductors in vertical raceways shall be supported if the vertical rise exceeds the values in Table 300.19(A). One cable support shall be provided at the top of the vertical raceway or as close to the top as practical. Intermediate supports shall be provided as necessary to limit supported conductor lengths to not greater than those values specified in Table 300.19(A).

*Exception: Steel wire armor cable shall be supported at the top of the riser with a cable support that clamps the steel wire armor. A safety device shall be permitted at the lower end of the riser to hold the cable in the event there is slippage of the cable in the wire-armored cable support. Additional wedge-type supports shall be permitted to relieve the strain on the equipment terminals caused by expansion of the cable under load.*

**TABLE 300.19(A). SPACINGS FOR CONDUCTOR SUPPORTS**

Size of Wire	Support of Conductors in Vertical Raceways	CONDUCTORS			
		Aluminum or Copper-Clad Aluminum		Copper	
		m	ft	m	ft
18 AWG through 8 AWG	Not greater than	30	100	30	100
6 AWG through 1/0 AWG	Not greater than	60	200	30	100
2/0 AWG through 4/0 AWG	Not greater than	55	180	25	80
Over 4/0 AWG through 350 kcmil	Not greater than	41	135	18	60
Over 350 kcmil through 500 kcmil	Not greater than	36	120	15	50
Over 500 kcmil through 750 kcmil	Not greater than	28	95	12	40
Over 750 kcmil	Not greater than	26	85	11	35

**(B) Support Methods.** One of the following methods of support shall be used.

- (1) By clamping devices constructed of or employing insulating wedges inserted in the ends of the raceways. Where clamping of insulation does not adequately support the cable, the conductor also shall be clamped.
- (2) By inserting boxes at the required intervals in which insulating supports are installed and secured in a satisfactory manner to withstand the weight of the conductors attached thereto, the boxes being provided with covers.
- (3) In junction boxes, by deflecting the cables not less than 90 degrees and carrying them horizontally to a distance not less than twice the diameter of the cable, the cables being carried on two or more insulating supports and additionally secured thereto by tie wires if desired. Where this method is used, cables shall be supported at intervals not greater than 20 percent of those mentioned in the preceding tabulation.
- (4) By a method of equal effectiveness.

### **300.21 Spread of fire or Products of Combustion**

Electrical installations in hollow spaces, vertical shafts, and ventilation or air-handling ducts shall be made so that the possible spread of fire or products of combustion will not be substantially increased. Openings around electrical penetrations through fire-resistance rated walls, partitions, floors, or ceilings shall be fire-stopped using approved methods to maintain the fire-resistance rating.

*FPN: Directories of electrical construction materials published by qualified testing laboratories contain many listing installation restrictions necessary to maintain the fire-resistive rating of assemblies where penetrations or openings are made. Building codes also contain restrictions on membrane penetrations on opposite sides of a fire-resistance-rated wall assembly. An example is the 600 mm (24 in.) minimum horizontal separation that usually applies between boxes installed on opposite sides of the wall. Assistance in complying with 300.21 can be found in building codes, fire resistance directories, and product listings.*

### **300.22 Wiring in Ducts, Plenums, and Other Air-Handling Spaces**



The provisions of this section apply to the installation and uses of electrical wiring and equipment in ducts, plenums, and other air-handling spaces.

*FPN: See Article 424, Part Y1 for Duct Heaters.*

**(A) Ducts for Dust, Loose Stock, or Vapor Removal.**

No wiring systems of any type shall be installed in ducts used to transport dust, loose stock, or flammable vapors. No wiring systems of any type shall be installed in any duct, or shaft containing only such ducts, used for vapor removal or for ventilation of commercial-type cooking equipment.

**(B) Ducts or Plenums Used for Environmental Air.**

Only wiring methods consisting of Type MI cable, Type MC cable employing a smooth or corrugated impervious metal sheath without an overall nonmetallic covering, electrical metallic tubing, flexible metallic tubing, intermediate metal conduit, or rigid metallic conduit without an overall nonmetallic covering shall be installed in ducts or plenums specifically fabricated to transport environmental air. Flexible metal conduit and liquidtight flexible metal conduit shall be permitted, in lengths not to exceed 1.2 m (4 ft), to connect physically adjustable equipment and devices permitted to be in these ducts and plenum chambers. The connectors used with flexible metal conduit shall effectively close any openings in the connection. Equipment and devices shall be permitted within such ducts or plenum chambers only if necessary for their direct action upon, or sensing of, the contained air. Where equipment or devices are installed and illumination is necessary to facilitate maintenance and repair, enclosed gasketed-type luminaires (fixtures) shall be permitted.

**(C) Other Space Used for Environmental Air.** This section applies to space used for environmental air-handling purposes other than ducts and plenums as specified in 300.22(A) and (B). It does not include habitable rooms or areas of buildings, the prime purpose of which is not air handling.

*FPN: The space over a hung ceiling used for environmental air-handling purposes is an example of the type of other space to which this section applies.*

*Exception: This section shall not apply to the joist or stud spaces of dwelling units where the wiring passes through such spaces perpendicular to the long dimension of such spaces.*

- (1) **Wiring Methods.** The wiring methods for such other space shall be limited to totally enclosed, nonventilated, insulated busway having no provisions for plug-in connections, Type MI cable, Type MC cable without an overall nonmetallic covering, Type AC cable, or other factory-assembled multiconductor control or power cable that is specifically listed for the use, or listed prefabricated cable assemblies of metallic manufactured wiring systems without nonmetallic sheath. Other type cables and conductors shall be installed in electrical metallic tubing, flexible metallic tubing, intermediate metal conduit, rigid metal conduit without an overall nonmetallic covering, flexible metal conduit, or, where accessible, surface metal raceway or metal wireway with metal covers or solid bottom metal cable tray with solid metal covers.
- (2) **Equipment.** Electrical equipment with a metal enclosure, or with a nonmetallic enclosure listed for the use and having adequate fire-resistant and low-smoke-producing characteristics, and associated wiring material suitable for the ambient temperature shall be permitted to be installed in such other space unless prohibited elsewhere in this Code.

*Exception: Integral fan systems shall be permitted where specifically identified for such use.*

**(D) Information Technology Equipment.** Electric wiring in air-handling areas beneath raised floors for information technology equipment shall be permitted in accordance with Article 645.

## **Article 356 – Liquidtight Flexible Nonmetallic Conduit: Type LFNC**

### **356.2 Definition.**

#### **Liquidtight Flexible Nonmetallic Conduit (LFNC).**

A raceway of circular cross section of various types as follows:

- (1) A smooth seamless inner core and cover bonded together and having one or more reinforcement layers between the core and covers, designated as Type LFNC-A

- (2) A smooth inner surface with integral reinforcement within the conduit wall, designated as Type LFNC-B
- (3) A corrugated internal and external surface without integral reinforcement within the conduit wall, designated as Type LFNC-C

LFNC is flame resistant and, with fittings, is approved for the installation of electrical conductors.

*FPN: FNMC is an alternative designation for LFNC.*

**356.10 Uses Permitted.** LFNC shall be permitted to be used in exposed or concealed locations, for the following purposes:

*FPN: Extreme cold may cause some types of nonmetallic conduits to become brittle and therefore more susceptible to damage from physical contact.*

- (1) Where flexibility is required for installation, operation, or maintenance
- (2) Where protection of the contained conductors is required from vapors, liquids, or solids
- (3) For outdoor locations where listed and marked as suitable for the purpose
- (4) For direct burial where listed and marked for the purpose
- (5) Type LFNC-B shall be permitted to be installed in lengths longer than 1.8 m (6 ft.) where secured in accordance with 356.30
- (6) Type LFNC-B as a listed manufactured prewired assembly, metric designator 16 through 27 (trade size 1/2 through 1) conduit

**356.12 Uses Not Permitted.** LFNC shall not be used as follows:

- (1) Where subject to physical damage
- (2) Where any combination of ambient and conductor temperatures is in excess of that for which the LFNC is approved
- (3) In lengths longer than 1.8 m (6 ft.), except as permitted by 356.100(5) or where a longer length is approved as essential for a required degree of flexibility
- (4) Where voltage of the contained conductors is in excess of 600 volts, nominal

## Article 314 — Outlet, Device, Pull, and Junction Boxes; Conduit Bodies; Fittings; and Manholes

### I. SCOPE AND GENERAL

**314.1 Scope.** This article covers the installation and use of all boxes and conduit bodies used as outlet, device, junction, or pull boxes, depending on their use, and manholes and other electric enclosures intended for personnel entry. Cast, sheet metal, nonmetallic, and other boxes such as FS, FD, and larger boxes are not classified as conduit bodies. This article also includes installation requirements for fittings used to join raceways and to connect raceways and cables to boxes and conduit bodies.

**314.2 Round Boxes.** Round boxes shall not be used where conduits or connectors requiring the use of lock nuts or bushings are to be connected to the side of the box.

**314.3 Nonmetallic Boxes.** Nonmetallic boxes shall be permitted only with open wiring on insulators, concealed knob-and-tube wiring, cabled wiring methods with entirely nonmetallic sheaths, flexible cords, and nonmetallic raceways.

*Exception No. 1: Where internal bonding means are provided between all entries, nonmetallic boxes shall be permitted to be used with metal raceways or metal-armored cables.*

*Exception No. 2: Where integral bonding means with a provision for attaching an equipment bonding jumper inside the box are provided between all threaded entries in non-metallic boxes listed for the purpose, nonmetallic boxes shall be permitted to be used with metal raceways or metal-armored cables.*

**314.4 Metal Boxes.** All metal boxes shall be grounded in accordance with the provisions of Article 250.

**314.17 Conductors Entering Boxes, Conduit Bodies, or Fittings.** Conductors entering boxes, conduit bodies, or fittings shall be protected from abrasion and shall comply with 314.17(A) through (D).

(A) **Openings to Be Closed.** Openings through which conductors enter shall be adequately closed.

(B) **Metal Boxes and Conduit Bodies.** Where metal boxes or conduit bodies are installed with open wiring or concealed knob-and-tube wiring, conductors shall enter through insulating bushings or, in dry locations, through flexible tubing extending from the last insulating support to not less than 6 mm (1/4 in.)

inside the box and beyond any cable clamps. Except as provided in 300.15(C), the wiring shall be firmly secured to the box or conduit body. Where raceway or cable is installed with metal boxes or conduit bodies, the raceway or cable shall be secured to such boxes and conduit bodies.

**(C) Nonmetallic Boxes and Conduit Bodies.**

Nonmetallic Boxes and Conduit Bodies shall be suitable for the lowest temperature-rated conductor entering the box. Where nonmetallic boxes are used with open wiring or concealed knob-and-tube wiring, the conductors shall enter the box through individual holes. Where flexible tubing is used to enclose the conductors, the tubing shall extend from the last insulating support to not less than 6 mm (1/4 in.) inside the box inside the box and beyond any cable clamp. Where nonmetallic-sheathed cable or multiconductor Type UF cable is used, the sheath shall extend not less than 6mm (1/4 in.) inside the box and beyond any cable clamp. In all instances, all permitted wiring methods shall be secured to the boxes.

*Exception: Where nonmetallic-sheathed cable or multiconductor Type UF cable is used with single gang boxes not larger than a nominal size 57 mm × 100 mm (2 1/4 in. × 4 in.) mounted in walls or ceilings, and where the cable is fastened within 200 mm (8 in.) of the box measured along the sheath and where the sheath extends through a cable knockout not less than 6 mm (1/4 in.), securing the cable to the box shall not be required. Multiple cable entries shall be permitted in a single cable knockout opening.*

**(D) Conductors No. 4 or Larger.** Installation shall comply with Section 300.4(F).

*FPN: See 110.12(A) for requirements on closing unused cable and raceway knockout openings.*

**314.20 In Wall or Ceiling.** In walls or ceilings with a surface of concrete, tile, gypsum, plaster, or other noncombustible material, boxes shall be installed so that the front edge of the box will not be set back of the finished surface more than 6 mm (1/4 in.).

In walls and ceilings constructed of wood or other combustible surface material, boxes shall be flush with the finished surface or project therefrom.

### **314.21 Repairing Plaster and Drywall or**

**Plaster-board.** Plaster, drywall, or plasterboard surfaces that are broken or incomplete shall be repaired so there will be no gaps or open spaces greater than 3 mm (1/8 in.) at the edge of the box or fitting.

**314.22 Exposed Surface Extensions.** Surface extensions from a flush-mounted box shall be made by mounting and mechanically securing an extension ring over the flush box. Equipment grounding and bonding shall be in accordance with Article 250.

*Exception: A surface extension shall be permitted to be made from the cover of a flush-mounted box where the cover is designed so it is unlikely to fall off, or be removed if its securing means becomes loose. The wiring method shall be flexible for a length sufficient to permit removal of the cover and provide access to the box interior, and arranged so that any bonding or grounding continuity is independent of the connection between the box and cover.*

**314.23 Supports.** Enclosures within the scope of this article shall be supported in accordance with one or more of the provisions in 314.23(A) through (H).

**(A) Surface Mounting.** An enclosure mounted on a building or other surface shall be rigidly and securely fastened in place. If the surface does not provide rigid and secure support, additional support in accordance with other provisions of this section shall be provided.

**(B) Structural Mounting.** An enclosure supported from a structural member of a building or from grade shall be rigidly supported either directly, or by using a metal, polymeric, or wood brace.

(1) Nails and screws. Nails and screws, where used as a fastening means, shall be attached by using brackets on the outside of the enclosure, or they shall pass through the interior within 6 mm (1/4 in.) of the back or ends of the enclosure.

(2) Braces. Metal braces shall be protected against corrosion and formed from metal that is not less than 0.020 in. (508 µm) thick uncoated. Wood braces shall have a cross section not less than nominal 1 in. × 2 in. Wood braces in wet locations shall be treated for the conditions. Polymeric braces shall be identified as being suitable for the use.

- (C) Mounting in Finished Surfaces.** An enclosure mounted in a finished surface shall be rigidly secured thereto by clamps, anchors, or fittings identified for the application.
- (D) Suspended Ceilings.** An enclosure mounted to structural or supporting elements of a suspended ceiling shall be not more than 1650 cm<sup>3</sup> (100 in.<sup>3</sup>) in size and shall be securely fastened in place in accordance with either (D)(1) or (D)(2).
- (1) **Framing Members.** An enclosure shall be fastened to the framing members by mechanical means such as bolts, screws, or rivets, or by the use of clips or other securing means identified for use with the type of ceiling framing member(s) and enclosure(s) employed. The framing members shall be adequately supported and securely fastened to each other and to the building structure.
- (2) **Support Wires.** The installation shall comply with the provisions of Section 300.11(A). The enclosure shall be secured, using methods identified for the purpose, to ceiling support wire(s), including any additional support wire(s) installed for that purpose. Support wire(s) used for enclosure support shall be fastened at each end so as to be taut within the ceiling cavity.
- (E) Raceway Supported Enclosure, Without Devices, Luminaires (Fixtures), or Lampholders.** An enclosure that does not contain a device(s) other than splicing devices or support a luminaire(s) [fixture(s)], lampholder, or other equipment and is supported by entering raceways shall not exceed 1650 cm<sup>3</sup> (100 in.<sup>3</sup>) in size. It shall have threaded entries or have hubs identified for the purpose. It shall be supported by two or more conduits threaded wrench-tight into the enclosure or hubs. Each conduit shall be secured within 900 mm (3 ft.) of the enclosure, or within 450 mm (18 in.) of the enclosure if all conduit entries are on the same side.

*Exception: Rigid metal, intermediate metal, or rigid nonmetallic conduit or electrical metallic tubing shall be permitted to support a conduit body of any size, including a conduit body constructed with only one conduit entry, provided the trade size of the conduit body is not larger*

than the largest trade size of the conduit or electrical metallic tubing.

**(F) Raceway Supported Enclosures, with Devices, Luminaires (Fixtures), or Lampholders.** An enclosure that contains a device(s) or supports a luminaire(s) [fixture(s)], lampholder, or other equipment and is supported by entering raceways shall not exceed 1650 cm<sup>3</sup> (100 in.<sup>3</sup>) in size. It shall have threaded entries or have hubs identified for the purpose. It shall be supported by two or more conduits threaded wrench-tight into the enclosure or hubs. Each conduit shall be secured within 450 mm (18 in.) of the enclosure.

*Exception No. 1: Rigid metal or intermediate metal conduit shall be permitted to support a conduit body of any size, including a conduit body constructed with only one conduit entry, provided the trade size of the conduit body is not larger than the largest trade size of the conduit.*

*Exception No. 2: An unbroken length(s) of rigid or intermediate metal conduit shall be permitted to support a box used for luminaire (fixture) or lampholder support, or to support a wiring enclosure that is an integral part of a luminaire (fixture) and used in lieu of a box in accordance with 300.15(B), where all of the following conditions are met.*

- (a) The conduit is securely fastened at a point so that the length of conduit beyond the last point of conduit support does not exceed 900 mm (3 ft).*
- (b) The unbroken conduit length before the last point of conduit support is 300 mm (12 in.) or greater, and that portion of the conduit is securely fastened at some point not less than 300 mm (12 in.) from its last point of support.*
- (c) Where accessible to unqualified persons, the luminaire (fixture), measured to its lowest point, is at least 2.5 m (8 ft.) above grade or standing area and at least 900 mm (3 ft.) measured horizontally to the 2.5 m (8 ft) elevation from windows, doors, porches, fire escapes, or similar locations.*
- (d) A luminaire (fixture) supported by a single conduit does not exceed 300 mm (12 in.) in any direction from the point of conduit entry.*
- (e) The weight supported by any single conduit does not exceed 9 kg (20 lbs.).*



(f) *At the luminaire (fixture) or lampholder end, the conduit(s) is threaded wrench-tight into the box, conduit body, or integral wiring enclosure, or into hubs identified for the purpose. Where a box or conduit body is used for support, the luminaire (fixture) shall be secured directly to the box or conduit body, or through a threaded conduit nipple not over 75 mm (3 in.) long.*

**(G) Enclosures in Concrete or Masonry.** An enclosure supported by embedment shall be identified as suitably protected from corrosion and securely embedded in concrete or masonry.

**(H) Pendant Boxes.** An enclosure supported by a pendant shall comply with 314.23(H)(1) or (2).

(1) **Flexible Cord.** A box shall be supported from a multiconductor cord or cable in an approved manner that protects the conductors against strain, such as a strain-relief connector threaded into a box with a hub.

(2) **Conduit.** A box supporting lampholders or luminaires (lighting fixtures), or wiring enclosures within luminaires (fixtures) used in lieu of boxes in accordance with Section 300.15(B), shall be supported by rigid or intermediate metal conduit stems. For stems longer than 450 mm (18 in.), the stems shall be connected to the wiring system with flexible fittings suitable for the location. At the luminaire (fixture) end, the conduit(s) shall be threaded wrench-tight into the box or wiring enclosure, or into hubs identified for the purpose.

Where supported by only a single conduit, the threaded joints shall be prevented from loosening by the use of set-screws or other effective means, or the luminaire (fixture), at any point, shall be at least 2.5 m (8 ft.) above grade or standing area and at least 900 mm (3 ft.) measured horizontally to the 2.5 m (8 ft.) elevation from windows, doors, porches, fire escapes, or similar locations. A luminaire (fixture) supported by a single conduit shall not exceed 300 mm (12 in.) in any horizontal direction from the point of conduit entry.

**314.25 Covers and Canopies.** In completed installations, each box shall have a cover, faceplate, lampholder, or luminaire (fixture) canopy, except where the installation complies with 410.14(B).

**(A) Nonmetallic or Metal Covers and Plates.**

Nonmetallic or metal covers and plates shall be permitted. Where metal covers or plates are used, they shall comply with the grounding requirements of Section 250.110.

*FPN: For additional grounding requirements, see Section 410.18(A) for metal luminaire (fixture) canopies, and 404.12 and 406.5(B) for metal faceplates.*

**(B) Exposed Combustible Wall or Ceiling Finish.**

Where a luminaire (fixture) canopy or pan is used, any combustible wall or ceiling finish exposed between the edge of the canopy or pan and the outlet box shall be covered with noncombustible material.

**(C) Flexible Cord Pendants.** Covers of outlet boxes and conduit bodies having holes through which flexible cord pendants pass shall be provided with bushings designed for the purpose or shall have smooth, well-rounded surfaces on which the cords may bear. So-called hard rubber or composition bushings shall not be used.

**314.27 Outlet Boxes.**

**(A) Boxes at Luminaire (Lighting Fixture) Outlets.**

Boxes used at luminaire (lighting fixture) or lampholder outlets shall be designed for the purpose. At every outlet used exclusively for lighting, the box shall be designed or installed so that a luminaire (lighting fixture) may be attached.

*Exception: A wall-mounted fixture weighing not more than 3 kg (6 lb.) shall be permitted to be supported on other boxes, provided the luminaire (fixture) or its supporting yoke is secured to the box with no fewer than two No. 6 or larger screws.*

**(B) Maximum Luminaire (Fixture) Weight.**

Outlet boxes or fittings installed as required by 314.23 shall be permitted to support luminaires (lighting fixtures) weighing 23 kg (50 lbs.) or less. A luminaire (lighting fixture) that weighs more than 23 kg (50 lbs.) shall be supported independently of the outlet box unless the outlet box is listed for the weight to be supported.

- (C) Floor Boxes.** Boxes listed specifically for this application shall be used for receptacles located in the floor.

*Exception: Where the authority having jurisdiction judges them free from likely exposure to physical damage, moisture, and dirt, boxes located in elevated floors of show windows and similar locations shall be permitted to be other than those listed for floor applications. Receptacles and covers shall be listed as an assembly for this type of location.*

- (D) Boxes at Ceiling-Suspended (Paddle) Fan Outlets.** Where a box is used as the sole support of a ceiling-suspended (paddle) fan, the box shall be listed for the application and for the weight of the fan to be supported. The installation shall comply with 422.18.

### **314.43 Nonmetallic Boxes.**

Provisions for supports or other mounting means for nonmetallic boxes shall be outside of the box, or the box shall be constructed so as to prevent contact between the conductors in the box and the supporting screws.

## **Article 410**

### **410.14 Connection of Electric-Discharge Luminaires (Lighting Fixtures).**

- (A) Independent of the Outlet Box.** Electric-discharge luminaires (lighting fixtures) supported independent of the outlet box shall be connected to the branch circuit through metal raceway, nonmetallic raceway, Type MC cable, Type AC cable, Type MI cable, non-metallic sheathed cable, or by flexible cord as permitted in 410.30(B) or (C).
- (B) Access to Boxes.** Electric-discharge luminaires (lighting fixtures) surface mounted over concealed outlet, pull, or junction boxes shall be installed with suitable openings in back of the fixture to provide access to the boxes.

### **410.67 Wiring.**

- (A) General.** Conductors that have insulation suitable for the temperature encountered shall be used.
- (B) Circuit Conductors.** Branch-circuit conductors that have an insulation suitable for the temperature encountered shall be permitted to terminate in the luminaire (fixture).

**(C) Tap Conductors.** Tap conductors of a type suitable for the temperature encountered shall be permitted to run from the luminaire (fixture) terminal connection to an outlet box placed at least 300 mm (1 ft.) from the fixture. Such tap conductors shall be in suitable raceway or Type AC or MC cable of at least 450 mm (18 in.) but not more than 1.8 m (6 ft) in length.

## **Article 504**

**504.20 Wiring Methods.** Intrinsically safe apparatus and wiring shall be permitted to be installed using any of the wiring methods suitable for unclassified locations, including Chapter 7 and Chapter 8. Sealing shall be as provided in Section 504.70, and separation shall be as provided in Section 504.30.

## **Article 505**

**505.15 Wiring Methods.** Wiring methods shall maintain the integrity of protection techniques and shall comply with 505.15(A), (B), or (C).

**(A) Class I, Zone 0.** In Class I, Zone 0 locations, only intrinsically safe wiring methods in accordance with Article 504 shall be permitted.

*FPN: Article 504 only includes protection technique "ia."*

## **Article 551 – Recreational Vehicles and Recreational Vehicle Parks**

### **551.47 Wiring Methods.**

**(G) Protected.** Metal-clad, Type AC, or nonmetallic-sheathed cables and electrical nonmetallic tubing shall be permitted to pass through the centers of the wide side of 2 × 4 wood studs. However, they shall be protected where they pass through 2 × 2 wood studs or at other wood studs or frames where the cable or tubing would be less than 32 mm (1¼ in.) from the inside or outside surface. Steel plates on each side of the cable or tubing, or a steel tube, with not less than 1.35 mm (0.053 in.) wall thickness, shall be installed to protect the cable or tubing. These plates or tubes shall be securely held in place. Where nonmetallic-sheathed cables pass through punched, cut, or drilled slots or holes in metal members, the cable shall be protected by bushings or grommets securely fastened in the opening prior to installation of the cable.

## **Article 552 – Park Trailers**

### **552.48 Wiring Methods.**

(G) **Protected.** Metal-clad, Type AC, or nonmetallic-sheathed cables and electrical nonmetallic tubing shall be permitted to pass through the centers of the wide side of 2 × 4 wood studs. However, they shall be protected where they pass through 2 × 2 wood studs or at other wood studs or frames where the cable or tubing would be less than 32 mm (1¼ in.) from the inside or outside surface. Steel plates on each side of the cable or tubing, or a steel tube, with not less than 1.35 mm (0.053 in.) wall thickness, shall be installed to protect the cable or tubing. These plates or tubes shall be securely held in place. Where nonmetallic-sheathed cables pass through punched, cut, or drilled slots or holes in metal members, the cable shall be protected by bushings or grommets securely fastened in the opening prior to installation of the cable.

## **Article 645 – Information Technology Equipment**

### **645.5 Under Raised Floors.**

(D) **Under Raised Floors.** Power cables, communications cables, connecting cables, interconnecting cables, and receptacles associated with the information technology equipment shall be permitted under a raised floor, provided the following conditions are met.

- (1) The raised floor is of suitable construction, and the area under the floor is accessible.
- (2) The branch-circuit supply conductors to receptacles or field-wired equipment are in rigid metal conduit, rigid nonmetallic conduit, intermediate metal conduit, electrical metallic tubing, electrical nonmetallic tubing, metal wireway, nonmetallic wireway, surface metal raceway with metal cover, nonmetallic surface raceway, flexible metal conduit, liquidtight flexible metal conduit, or liquidtight flexible nonmetallic conduit, Type MI cable, Type MC cable, or Type AC cable. These supply conductors shall be installed in accordance with the requirements of 300.11.
- (3) Ventilation in the underfloor area is used for the information equipment room only. The ventilation

system shall be so arranged, with approved smoke detection devices, that upon the detection of fire or products of combustion in the underfloor space the circulation of air will cease.

- (4) Openings in raised floors for cables protect cables against abrasions and minimize the entrance of debris beneath the floor.
- (5) Cables, other than those covered in (2) and those complying with (a), (b), and (c), shall be listed as Type DP cable having adequate fire-resistant characteristics suitable for use under raised floors of an information technology equipment room.
  - (a) Interconnecting cables enclosed in a raceway.
  - (b) Interconnecting cables listed with equipment manufactured prior to July 1, 1994, being installed with that equipment.
  - (c) Cable type designations Type TC (Article 336); Types CL2, CL3, and PLTC (Article 725); Type ITC (Article 727), Types NPLF and FPL (Article 760); Types OFC and OFN (Article 770); Types CM and MP (Article 800); and Type CATV (Article 820). These designations shall be permitted to have an additional letter P or R or G. Green, with one or more yellow stripes, insulated single conductor cables, 4 AWG and larger, marked "for use in cable trays" or "for CT use" shall be permitted for equipment grounding.

*FPN: One method of defining fire resistance is by establishing that the cables do not spread fire to the top of the tray in the "Vertical Tray Flame Test" referenced in ANSI/UL 1581-1991, Standard for Electrical Wires, Cables, and Flexible Cords. Another method of defining fire resistance is for the damage (char length) not to exceed 1.5 m (4 ft. 11 in.) when performing the CSA "Vertical Flame Test – Cables in Cable Trays," as described in CSA C22.2 No. 0.3-M-1985, Test Methods for Electrical Wires and Cables.*

- (6) Abandoned cables shall not be permitted to remain unless contained in metal raceways.

# Section 11

---

## Miscellaneous



### TEMPORARY POWER

Use the permanent ENT wiring and permanent fixtures for temporary lighting (above) or use permanent ENT, wiring and permanent fixtures for temporary lighting (below).



# Section 12

## Flex-Plus® Blue™ ENT

### ELECTRICAL NONMETALLIC TUBING – COILS



LR83580



LISTED E73317

Listed for use with 90°C conductors

Part No.	Size	O.D.	Wt. Per 100 Ft.	Coil Length
<b>Standard Carlon Blue* – for Power Conductors</b>				
12005-200	1/2"	.840	11	200
12007-100	3/4"	1.050	14	100
12008-100	1"	1.315	22	100

#### Yellow\*\* – Recommended for Communications Conductors

12005Y-200	1/2"	.840	11	200
12007Y-100	3/4"	1.050	14	100
12008Y-100	1"	1.315	20	100

#### Red\*\* – Recommended for Fire-Protective Signaling Conductors

12005R-200	1/2"	.840	11	200
12007R-100	3/4"	1.050	14	100
12008R-100	1"	1.315	20	100

### ELECTRICAL NONMETALLIC TUBING – 10 FT. LENGTHS



LR83580



LISTED E73317

Listed for use with 90°C conductors

Part No.	Size	O.D.	Wt. Per 100 Ft.	10 Ft. Lengths Ft. Per Bundle	Feet per Lift
<b>Standard Carlon Blue* – for Power Conductors</b>					
12005-010	1/2"	.840	11	200	6400
12007-010	3/4"	1.050	14	100	4000
12008-010	1"	1.315	20	100	3200

Yellow and Red ENT may show color deterioration in direct sunlight over an extended period of time. It is suggested that all ENT products not be stored outside. Since this product is not intended for use outdoors, it should not be exposed to extended periods of direct sunlight.

\*The solid blue color of ENT conduit used for power conductors is a registered trademark of Carlon.

\*\*Colors other than standard Carlon blue are available on special order only. All fittings and boxes are standard Carlon blue. The development of red and yellow tubing was accomplished at the request of engineers desiring color coded conduits to identify fire protective signaling conductors and communication conductors on the job for safety purposes. Carlon Flex-Plus Blue ENT continues to indicate to the trade, as it always has, a conduit for power conductors made solely by Carlon.



## ELECTRICAL NONMETALLIC TUBING – REELS



LR83580



LISTED E73317

Listed for use with 90°C conductors

Part No.	Size	O.D.	Wt. Per 100 Ft.	Reel Length
<b>Standard Carlon Blue</b>				
12005AK-001	1/2"	.840	11	1500
12007AA-001	3/4"	1.050	14	1000
12008-750	1"	1.315	20	750
12009-750	1 1/4"	1.660	19	750
12010-750	1 1/2"	1.990	27	750
12011-500	2"	2.375	32	500
<b>Yellow</b>				
1205AKY-001	1/2"	.840	11	1500
1207AAY-001	3/4"	1.050	14	1000
12008Y-750	1"	1.315	20	750
<b>Red</b>				
1207AAR-001	1/2"	.840	11	200
1207AKR-100	3/4"	1.050	14	100
12008R-750	1"	1.315	20	100

### Approved Uses:

- Concrete slab ref. 2002 NEC Article 362
- Walls – wood stud, masonry and metal stud ref. 2002 NEC Article 362
- Ceilings – permanent or dropped (free air only) ref. 2002 NEC Article 362
- Exposed – including buildings not in excess of 3 stories ref. 2002 NEC Article 362
- Public Assembly ref. 2002 NEC Article 518

## ONE PIECE QUICK CONNECT FLEX-PLUS® BLUE™ FITTINGS AND ACCESSORIES



LR92248 LISTED E86720 Except where noted by ►



### ONE PIECE QUICK CONNECT COUPLING

Part No.	Size	Pkg. Qty.
A240D	1/2"	150
A240E	3/4"	100
A240F	1"	50

Patent Pending



### ONE PIECE QUICK CONNECT THREADED MALE ADAPTERS

Part No.	Size	Pkg. Qty.
A243D	1/2"	150
A243E	3/4"	100
A243F	1"	50

Patent Pending



### ONE PIECE QUICK CONNECT SNAP-IN TERMINATOR ADAPTERS

Part No.	Size	Pkg. Qty.
A253D	1/2"	150
A253E	3/4"	100
A253F	1"	50

Patent Pending

Carlson's One Piece ENT Quick Connect Couplings, Threaded Adapter and Transition Adapters are suitable for damp locations and are concrete-tight when used with Carlson ENT.

All Schedule 40 fittings are compatible with the ENT Couplings, Threaded Adapter and Transition Adapters with the use of ENT cement.

Schedule 40 fittings are recommended for use with Carlson 1 1/4" to 2" Flex-Plus® Blue ENT, and may be used with ENT 1/2" through 1".

When One Piece Quick Connect Snap-In Terminator Adapters are installed in a concrete application, Carlson's flat sealing washers must be used on the box connection ends.

### FLAT WASHER

Part No.	Size	Pkg. Qty.
► E943DW	1/2"	125
► E943EW	3/4"	125
► E943FW	1"	100

## QUICK CONNECT OUTLET AND SWITCH BOXES (IN CARLON BLUE)

\*Suitable for masonry walls



LISTED E42728

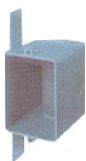

Part No.	Size	Pkg. Qty.
<b>Single Gang – 16 cu. in.</b>		
A58381D	3 × 2 1/2 × 3 (1/2" KO's)	25
A58381E	3 × 2 1/4 × 3 (3/4" KO's)	25



Part No.	Size	Pkg. Qty.
<b>4 Inch Square Boxes – 20 cu. in.</b>		
A52151D	4 × 4 × 1 1/2 (1/2" KO's)	100
A52151E	4 × 4 × 1 1/2 (3/4" KO's)	100
A52151DE	4 × 4 × 1 1/2 (1/2" & 3/4" KO's)	100



Part No.	Size	Pkg. Qty.
<b>4 Inch Square Boxes – 30.3 cu. in.</b>		
A52171D	4 × 4 × 2 3/8 (1/2" KO's)	25
A52171E	4 × 4 × 2 3/8 (3/4" KO's)	25
A52171DE	4 × 4 × 2 3/8 (1/2" & 3/4" KO's)	25



LISTED E42728

## ENT BOX WITH ADAPTERS



Part No.	Size	Pkg. Qty.
<b>4 Inch Square Boxes – 24.75 cu. in.</b>		
A5329DE	4 × 4 × 1 3/4 (1/2" & 3/4" KO's)	50

## 2 1/2" & 4" MUD BOXES WITH COVERS (IN CARLON BLUE)

Listed for use with fixtures up to 50 lbs. and ceiling fans up to 35 lbs.



LR31146



LISTED E42728



### Base Rings

Part No.	Description	Pkg. Qty.
A861	Without ground lug	10



### Covers

Part No.	Size	Pkg. Qty.
A862D	2 1/2" Deep (1/2" KO's)	10
A862E	2 1/2" Deep (3/4" KO's)	10
A864D	4" Deep (1/2" KO's)	10
A864E	4" Deep (3/4" KO's)	10
A864F	4" Deep (1" KO's)	10

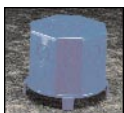

## SQUARE COVERS (IN CARLON BLUE) Square Covers for Outlet and Switch boxes



Part No.	Rise	Cu. in.	Pkg. Qty.
<b>Single Gang</b>			
A410	1/2"	3.5	100
A411	5/8"	4.2	50
A412	3/4"	5.0	50
A413	1"	6.6	40
A414	1 1/4"	8.1	30
<b>Two Gang</b>			
A400	Blank	—	100
A420	1/2"	6.1	75
A421	5/8"	7.4	50
A422	3/4"	8.8	50

## BOX BACK WALL SUPPORT



Part No.	Size	Pkg. Qty.
A540DS	1/2" Knockout	100

Carlton's ceiling boxes and round plaster rings are produced from a special high heat resistant engineered plastic material developed specifically for fixture support.

## QUICK CONNECT 4" OCTAGON CEILING BOXES (IN CARLON BLUE) Listed for use with fixtures up to 50 lbs.



Part No.	Size	Pkg. Qty.	
 Ceiling Box 20.5 cu. in.	A615D	4" - 2 1/8" Deep (1/2" KO's)	50
	A615E	(3/4" KO's)	50
	A615DE	(1/2" & 3/4" KO's)	50
 Ceiling Box w/ J Mount 20.5 cu. in.	A615DJ	4" - 2 1/8" Deep (1/2" KO's)	50
 Ceiling Box w/ L Bracket 20.5 cu. in.	A615DL	4" - 2 1/8" Deep (1/2" KO's)	50
 Ceiling Box w/ Adjustable Hanger Bar* - 20.5 cu. in. *Adjusts from 1 1/4" to 2 3/4"	A615DH	4" - 2 1/8" Deep (1/2" KO's)	25

## ROUND PLASTER RING (IN CARLON BLUE)



LISTED E42728



### Round Covers for Octagon Ceiling Boxes

Part No.	Rise	Cu. in.	Pkg. Qty.
A471	1/2"	3.2	100
A472	5/8"	4.0	100

## ROUND BLANK COVERS (IN CARLON BLUE)



Part No.	Rise	Cu. in.	Pkg. Qty.
E460R-CAR	Blank	—	35
A470D	Blank w/ 1/2" KO	—	100

## CONDUIT CUTTERS

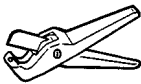

Tool length 8"

Item	Part No.	Std. Pkg. Qty.	Std. Pkg. Wt.
Small Conduit Cutter	CC120B	10	8

For fast, smooth field cuts of 1/2" through 1" Schedule 40 and 80 rigid nonmetallic conduit, Flex-Plus® Blue™ ENT, and Carflex® liquidtight flexible nonmetallic.

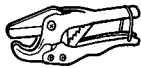

Tool length 9"

Item	Part No.	Std. Pkg. Qty.	Std. Pkg. Wt.
Medium Conduit Cutter	CC125	12	13

For fast, smooth field cuts of 1/2" through 1 1/4" conduits and tubing



Tool length 17 1/2"

Item	Part No.	Std. Pkg. Qty.	Std. Pkg. Wt.
Large Conduit Cutter	CC122	1	2.5

For fast, smooth field cuts of 1/2" through 2" nonmetallic conduits and tubing

## ENT CEMENT



Part No.	Size	Std. Ctn. Qty.
VC9993	Pt. - Brush Top	24
VC9992	Qt. - Brush Top	12

See ENT cementing instructions below.

## CONCRETE ENCASEMENT GUIDELINES

Carlon's new quick connect one piece fittings are approved for concrete-tight installations. For sizes larger than 1" the use of standard Carlon solvent weld fittings with the proper ENT Cement is recommended.

1. ENT should be tied to rebar at 2-3 foot intervals to prevent flotation. Suitable materials include wire, tie wraps, and tape.
2. When using UL solvent weld fittings for concrete tight performance:

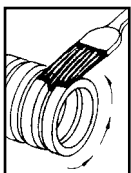

- A. Do not use chemical primer or cleaner.
- B. Apply a light, uniform coat of cement labeled for use with ENT, on the coupling and ENT.
- C. Do not use a dauber.
- D. Brush excess cement out of ENT grooves.

- E. Promptly insert ENT into fitting while cement is wet, until the stop is reached, and give a quarter turn.

- F. Do not disturb until joint is set.

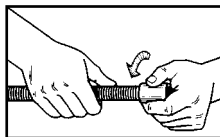

New snap in fittings do not require taping. The threaded male adapter does not require O-ring, only the snap in terminator requires the flat washer.

3. Junctions box connections made with threaded male terminal adapters may require the use of an O-ring to make a water or concrete-tight connection.

# ENT Specifications

## GUIDE SPECIFICATION FOR ENT

- Electrical Nonmetallic Tubing (ENT) is designed to replace EMT, flexible metal conduit or other raceway systems in accordance with Article 362 of the National Electrical Code, other applicable sections of the Code and local codes.
- Any ENT used shall be listed to the requirements of UL 1653 and meets NEMA TC-13.
- ENT shall be recognized by The National Evaluation Service, Inc. for use in fire resistive construction.
- Penetration of fire rated walls, floors or ceilings shall use classified Through-Penetration Firestop Systems described in the current Underwriters Laboratories Fire Resistance Directory.
- Fittings and outlet boxes shall be designed for use with ENT and listed by Underwriters Laboratories. All fittings, boxes and accessories shall be manufactured by CARLON.
- Only CARLON ENT Blue cement recommended specifically for use with ENT and PVC Schedule 40 fittings shall be used.
- Unless indicated differently on drawings, ENT systems shall be color coded: BLUE, YELLOW, or RED. ENT can be used for identifications.

## FEATURES

- UL Listed, Trade Sizes (1/2" to 2")
- UL recognizes the use of PVC Schedule 40 cement type fittings with all sizes of ENT
- ENT ambient temperature range -4°F (installation to 122°F)
- ENT rated for 90°C conductors
- One piece ENT Coupling, Threaded Terminator and Schedule 40 Transition Fitting are rated concrete tight without tape by UL Recognized in current NEC ref. Article 362
- Recognized for use in 2-hour fire resistive nonload bearing and load bearing wall assemblies per NER-290 and ER-5644

- Recognized for use in 1-hour fire resistive nonload bearing wall assemblies per NER-290 and ER-5644
- Recognized for use in a fire resistive ceiling assembly (up to 3 hours) per NER-290 and ER-5644
- Recognized for Through-Penetration Firestop systems as classified by UL to meet BOCA, SBCCI and ICBO codes
- Nonconductive/noncorrosive pliable raceway system
- Packaged in sticks, coils and reels
- Available in three colors: Blue, Yellow and Red for color coding
- Complete line of fittings & accessories specifically designed for use with ENT
- Hand bendable – does not require special tools\*
- Easy to cut length needed for installation – reduces scrap\*
- Conductors easily push through the raceway (up to approximately 50 feet)\*
- Lightweight makes it easy to handle on the job\*

\*Speed of installation keeps the job on schedule despite unexpected obstacles. Lower installation costs allow for savings to be reallocated to upgrade other areas, such as lighting, dimming, etc.

### **APPROVED USES:**

- Concrete slab ref. current NEC Article 362
- Walls – wood stud, masonry and metal stud ref. current NEC Article 362
- Ceilings – permanent or dropped (free air only) ref. current NEC Article 362
- Exposed – including buildings not in excess of 3 stories ref. current NEC Article 362
- Public Assembly ref. current NEC Section 518-4, in nonfire rated and certain fire rated structures
- Prewired, current NEC Article 362
- Classified by UL 1479 for Through Penetration Firestop Systems in UL Guide Category XHEZ and current UL Fire Resistance Directory
- Three hour rated floor/ceiling assembly



## **TYPICAL APPLICATIONS:**

- Residential: Low or high rise – multi or single family
- Commercial: Low or high rise – office, shopping malls, retail, hotel/motel, restaurant, etc.
- Nursing Homes/Hospitals in nonpatient care areas only
- Schools, classrooms, dormitories, offices
- Fire Alarm Systems
- Recreational vehicles and parks
- Marinas and boatyards
- Information Technology equipment
- Other uses per the current NEC



In USA, contact:  
25701 Science Park Drive  
Cleveland, Ohio 44122  
1-800-3-CARLON (1-800-322-7566)  
In Ohio, (216) 464-3400  
Fax: (216) 766-6444  
TDD/Hearing Impaired Access (216) 831-5918  
[www.carlon.com](http://www.carlon.com)

In Canada, contact:  
c/o Multimodal Logistics  
415 Traders Boulevard East  
Mississauga, Ontario  
Canada L4Z 1P2  
(905) 755-1262 ■ (888) 269-9902  
Fax: (905) 755-1265 ■ (888) 229-8622